

ARM® Cortex®-M4 32b MCU+FPU, 225DMIPS, up to 2MB Flash/384+4KB RAM, USB OTG HS/FS, Ethernet, FMC, dual Quad-SPI, Graphical accelerator, Camera IF, LCD-TFT & MIPI DSI

Datasheet - production data

Features

- Core: ARM® 32-bit Cortex®-M4 CPU with FPU, Adaptive real-time accelerator (ART Accelerator™) allowing 0-wait state execution from Flash memory, frequency up to 180 MHz, MPU, 225 DMIPS/1.25 DMIPS/MHz (Dhystone 2.1), and DSP instructions
- Memories
 - Up to 2 MB of Flash memory organized into two banks allowing read-while-write
 - Up to 384+4 KB of SRAM including 64-KB of CCM (core coupled memory) data RAM
 - Flexible external memory controller with up to 32-bit data bus: SRAM, PSRAM, SDRAM/LPSDR, SDRAM, Flash NOR/NAND memories
 - Dual-flash mode Quad-SPI interface
- Graphics:
 - Chrom-ART Accelerator™ (DMA2D), graphical hardware accelerator enabling enhanced graphical user interface with minimum CPU load
 - LCD parallel interface, 8080/6800 modes
 - LCD TFT controller supporting up to XGA resolution
 - MIPI® DSI host controller supporting up to 720p 30Hz resolution
- Clock, reset and supply management
 - 1.7 V to 3.6 V application supply and I/Os
 - POR, PDR, PVD and BOR
 - 4-to-26 MHz crystal oscillator
 - Internal 16 MHz factory-trimmed RC (1% accuracy)
 - 32 kHz oscillator for RTC with calibration
 - Internal 32 kHz RC with calibration
- Low power
 - Sleep, Stop and Standby modes
 - V_{BAT} supply for RTC, 20×32 bit backup registers + optional 4 KB backup SRAM
- 3×12-bit, 2.4 MSPS ADC: up to 24 channels and 7.2 MSPS in triple interleaved mode
- 2×12-bit D/A converters
- General-purpose DMA: 16-stream DMA controller with FIFOs and burst support
- Up to 17 timers: up to twelve 16-bit and two 32-bit timers up to 180 MHz, each with up to 4 IC/OC/PWM or pulse counter and quadrature (incremental) encoder input. 2x watchdogs and SysTick timer

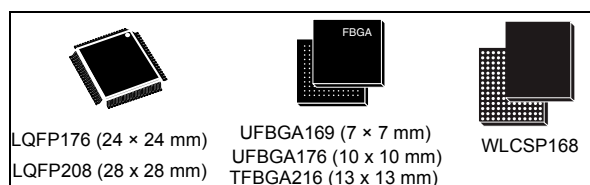

- Debug mode
 - SWD & JTAG interfaces
 - Cortex®-M4 Trace Macrocell™
- Up to 161 I/O ports with interrupt capability
 - Up to 157 fast I/Os up to 90 MHz
 - Up to 159 5 V-tolerant I/Os
- Up to 21 communication interfaces
 - Up to 3 × I²C interfaces (SMBus/PMBus)
 - Up to 4 USARTs and 4 UARTs (11.25 Mbit/s, ISO7816 interface, LIN, IrDA, modem control)
 - Up to 6 SPIs (45 Mbits/s), 2 with muxed full-duplex I²S for audio class accuracy via internal audio PLL or external clock
 - 1 × SAI (serial audio interface)
 - 2 × CAN (2.0B Active)
 - SDIO interface
- Advanced connectivity
 - USB 2.0 full-speed device/host/OTG controller with on-chip PHY
 - USB 2.0 high-speed/full-speed device/host/OTG controller with dedicated DMA, on-chip full-speed PHY and ULPI
 - Dedicated USB power rail enabling on-chip PHYs operation throughout the entire MCU power supply range
 - 10/100 Ethernet MAC with dedicated DMA: supports IEEE 1588v2 hardware, MII/RMII
- 8- to 14-bit parallel camera interface up to 54 Mbytes/s
- True random number generator
- CRC calculation unit
- RTC: subsecond accuracy, hardware calendar
- 96-bit unique ID

Table 1. Device summary

Reference	Part numbers
STM32F469xx	STM32F469AE, STM32F469AG, STM32F469AI STM32F469BE, STM32F469BG, STM32F469BI STM32F469IE, STM32F469IG, STM32F469II STM32F469NE, STM32F469NG, STM32F469NI

Contents

1	Description	11
1.1	Compatibility throughout the family	14
1.1.1	LQFP176 package	14
1.1.2	LQFP208 package	15
1.1.3	UFPGA176 package	16
1.1.4	TFPGA216 package	17
2	Functional overview	19
2.1	ARM® Cortex®-M4 with FPU and embedded Flash and SRAM	19
2.2	Adaptive real-time memory accelerator (ART Accelerator™)	19
2.3	Memory protection unit	19
2.4	Embedded Flash memory	20
2.5	CRC (cyclic redundancy check) calculation unit	20
2.6	Embedded SRAM	20
2.7	Multi-AHB bus matrix	20
2.8	DMA controller (DMA)	21
2.9	Flexible Memory Controller (FMC)	22
2.10	Quad-SPI memory interface (QUADSPI)	23
2.11	LCD-TFT controller	23
2.12	DSI Host (DSIHOST)	23
2.13	Chrom-ART Accelerator™ (DMA2D)	25
2.14	Nested vectored interrupt controller (NVIC)	25
2.15	External interrupt/event controller (EXTI)	25
2.16	Clocks and startup	26
2.17	Boot modes	26
2.18	Power supply schemes	26
2.19	Power supply supervisor	28
2.19.1	Internal reset ON	28
2.19.2	Internal reset OFF	28
2.20	Voltage regulator	29
2.20.1	Regulator ON	29
2.20.2	Regulator OFF	30

2.20.3	Regulator ON/OFF and internal reset ON/OFF availability	32
2.21	Real-time clock (RTC), backup SRAM and backup registers	33
2.22	Low-power modes	34
2.23	V _{BAT} operation	34
2.24	Timers and watchdogs	35
2.24.1	Advanced-control timers (TIM1, TIM8)	35
2.24.2	General-purpose timers (TIMx)	36
2.24.3	Basic timers TIM6 and TIM7	36
2.24.4	Independent watchdog	36
2.24.5	Window watchdog	37
2.24.6	SysTick timer	37
2.25	Inter-integrated circuit interface (I ² C)	37
2.26	Universal synchronous/asynchronous receiver transmitters (USART)	37
2.27	Serial peripheral interface (SPI)	38
2.28	Inter-integrated sound (I ² S)	39
2.29	Serial Audio interface (SAI1)	39
2.30	Audio PLL (PLLI2S)	39
2.31	Audio and LCD PLL(PLLSAI)	39
2.32	Secure digital input/output interface (SDIO)	40
2.33	Ethernet MAC interface with dedicated DMA and IEEE 1588 support	40
2.34	Controller area network (bxCAN)	40
2.35	Universal serial bus on-the-go full-speed (OTG_FS)	41
2.36	Universal serial bus on-the-go high-speed (OTG_HS)	41
2.37	Digital camera interface (DCMI)	42
2.38	Random number generator (RNG)	42
2.39	General-purpose input/outputs (GPIOs)	42
2.40	Analog-to-digital converters (ADCs)	43
2.41	Temperature sensor	43
2.42	Digital-to-analog converter (DAC)	43
2.43	Serial wire JTAG debug port (SWJ-DP)	44
2.44	Embedded Trace Macrocell™	44
3	Pinouts and pin description	45

4	Memory mapping	80
5	Electrical characteristics	85
5.1	Parameter conditions	85
5.1.1	Minimum and maximum values	85
5.1.2	Typical values	85
5.1.3	Typical curves	85
5.1.4	Loading capacitor	85
5.1.5	Pin input voltage	85
5.1.6	Power supply scheme	86
5.1.7	Current consumption measurement	87
5.2	Absolute maximum ratings	87
5.3	Operating conditions	89
5.3.1	General operating conditions	89
5.3.2	VCAP1/VCAP2 external capacitor	91
5.3.3	Operating conditions at power-up / power-down (regulator ON)	92
5.3.4	Operating conditions at power-up / power-down (regulator OFF)	92
5.3.5	Reset and power control block characteristics	92
5.3.6	Over-drive switching characteristics	94
5.3.7	Supply current characteristics	94
5.3.8	Wakeup time from low-power modes	110
5.3.9	External clock source characteristics	110
5.3.10	Internal clock source characteristics	114
5.3.11	PLL characteristics	116
5.3.12	PLL spread spectrum clock generation (SSCG) characteristics	119
5.3.13	MIPI D-PHY characteristics	120
5.3.14	MIPI D-PHY PLL characteristics	123
5.3.15	MIPI D-PHY regulator characteristics	124
5.3.16	Memory characteristics	125
5.3.17	EMC characteristics	127
5.3.18	Absolute maximum ratings (electrical sensitivity)	128
5.3.19	I/O current injection characteristics	129
5.3.20	I/O port characteristics	130
5.3.21	NRST pin characteristics	136
5.3.22	TIM timer characteristics	137
5.3.23	Communications interfaces	137
5.3.24	12-bit ADC characteristics	152

5.3.25	Temperature sensor characteristics	158
5.3.26	V _{BAT} monitoring characteristics	158
5.3.27	Reference voltage	158
5.3.28	DAC electrical characteristics	159
5.3.29	FMC characteristics	161
5.3.30	Quad-SPI interface characteristics	181
5.3.31	Camera interface (DCMI) timing specifications	182
5.3.32	LCD-TFT controller (LTDC) characteristics	183
5.3.33	SD/SDIO MMC card host interface (SDIO) characteristics	185
5.3.34	RTC characteristics	187
6	Package information	188
6.1	WLCSP168 package information	188
6.2	UFBGA169 package information	190
6.3	LQFP176 package information	192
6.4	UFBGA176+25 package information	196
6.5	LQFP208 package information	198
6.6	TFBGA216 package information	202
6.7	Thermal characteristics	204
7	Part numbering	205
Appendix A	Recommendations when using internal reset OFF	206
A.1	Operating conditions	206
8	Revision history	207

List of tables

Table 1.	Device summary	1
Table 2.	STM32F469xx features and peripheral counts	12
Table 3.	Voltage regulator configuration mode versus device operating mode	30
Table 4.	Regulator ON/OFF and internal reset ON/OFF availability	32
Table 5.	Voltage regulator modes in stop mode	34
Table 6.	Timer feature comparison	35
Table 7.	Comparison of I2C analog and digital filters	37
Table 8.	USART feature comparison	38
Table 9.	Legend/abbreviations used in the pinout table	51
Table 10.	STM32F469xx pin and ball definitions	52
Table 11.	FMC pin definition	67
Table 12.	Alternate function	70
Table 13.	STM32F469xx register boundary addresses	81
Table 14.	Voltage characteristics	87
Table 15.	Current characteristics	88
Table 16.	Thermal characteristics	88
Table 17.	General operating conditions	89
Table 18.	Limitations depending on the operating power supply range	91
Table 19.	VCAP1/VCAP2 operating conditions	92
Table 20.	Operating conditions at power-up / power-down (regulator ON)	92
Table 21.	Operating conditions at power-up / power-down (regulator OFF)	92
Table 22.	Reset and power control block characteristics	93
Table 23.	Over-drive switching characteristics	94
Table 24.	Typical and maximum current consumption in Run mode, code with data processing running from Flash memory (ART accelerator enabled except prefetch) or RAM, regulator ON	96
Table 25.	Typical and maximum current consumption in Run mode, code with data processing running from Flash memory (ART accelerator disabled), regulator ON	97
Table 26.	Typical and maximum current consumption in Run mode, code with data processing running from Flash memory (ART accelerator enabled except prefetch), regulator OFF	98
Table 27.	Typical and maximum current consumption in Sleep mode, regulator ON	99
Table 28.	Typical and maximum current consumption in Sleep mode, regulator OFF	100
Table 29.	Typical and maximum current consumption in Stop mode	101
Table 30.	Typical and maximum current consumption in Standby mode	102
Table 31.	Typical and maximum current consumption in V _{BAT} mode	103
Table 32.	Switching output I/O current consumption	105
Table 33.	Peripheral current consumption	107
Table 34.	Low-power mode wakeup timings	110
Table 35.	High-speed external user clock characteristics	111
Table 36.	Low-speed external user clock characteristics	111
Table 37.	HSE 4-26 MHz oscillator characteristics	112
Table 38.	LSE oscillator characteristics (f _{LSE} = 32.768 kHz)	114
Table 39.	HSI oscillator characteristics	114
Table 40.	LSI oscillator characteristics	116
Table 41.	Main PLL characteristics	116
Table 42.	PLL12S (audio PLL) characteristics	117
Table 43.	PLLSAI (audio and LCD-TFT PLL) characteristics	118

Table 44.	SSCG parameters constraint	119
Table 45.	MIPI D-PHY characteristics	120
Table 46.	MIPI D-PHY AC characteristics LP mode and HS/LP transitions	122
Table 47.	DSI-PLL characteristics	123
Table 48.	DSI regulator characteristics	124
Table 49.	Flash memory characteristics	125
Table 50.	Flash memory programming	125
Table 51.	Flash memory programming with V_{PP}	126
Table 52.	Flash memory endurance and data retention	127
Table 53.	EMS characteristics	127
Table 54.	EMI characteristics	128
Table 55.	ESD absolute maximum ratings	129
Table 56.	Electrical sensitivities	129
Table 57.	I/O current injection susceptibility	130
Table 58.	I/O static characteristics	130
Table 59.	Output voltage characteristics	133
Table 60.	I/O AC characteristics	134
Table 61.	NRST pin characteristics	136
Table 62.	TIMx characteristics	137
Table 63.	I2C analog filter characteristics	137
Table 64.	SPI dynamic characteristics	138
Table 65.	I ² S dynamic characteristics	142
Table 66.	SAI characteristics	144
Table 67.	USB OTG full speed startup time	146
Table 68.	USB OTG full speed DC electrical characteristics	146
Table 69.	USB OTG full speed electrical characteristics	147
Table 70.	USB HS DC electrical characteristics	147
Table 71.	USB HS clock timing parameters	148
Table 72.	Dynamic characteristics: USB ULPI	149
Table 73.	Ethernet DC electrical characteristics	149
Table 74.	Dynamics characteristics: Ethernet MAC signals for SMI	150
Table 75.	Dynamics characteristics: Ethernet MAC signals for RMII	151
Table 76.	Dynamics characteristics: Ethernet MAC signals for MII	151
Table 77.	ADC characteristics	152
Table 78.	ADC static accuracy at $f_{ADC} = 18$ MHz	154
Table 79.	ADC static accuracy at $f_{ADC} = 30$ MHz	154
Table 80.	ADC static accuracy at $f_{ADC} = 36$ MHz	154
Table 81.	ADC dynamic accuracy at $f_{ADC} = 18$ MHz - limited test conditions	155
Table 82.	ADC dynamic accuracy at $f_{ADC} = 36$ MHz - limited test conditions	155
Table 83.	Temperature sensor characteristics	158
Table 84.	Temperature sensor calibration values	158
Table 85.	V_{BAT} monitoring characteristics	158
Table 86.	internal reference voltage	158
Table 87.	Internal reference voltage calibration values	159
Table 88.	DAC characteristics	159
Table 89.	Asynchronous non-multiplexed SRAM/PSRAM/NOR - read timings	163
Table 90.	Asynchronous non-multiplexed SRAM/PSRAM/NOR read - NWAIT timings	163
Table 91.	Asynchronous non-multiplexed SRAM/PSRAM/NOR write timings	164
Table 92.	Asynchronous non-multiplexed SRAM/PSRAM/NOR write - NWAIT timings	165
Table 93.	Asynchronous multiplexed PSRAM/NOR read timings	166
Table 94.	Asynchronous multiplexed PSRAM/NOR read-NWAIT timings	166
Table 95.	Asynchronous multiplexed PSRAM/NOR write timings	167

Table 96.	Asynchronous multiplexed PSRAM/NOR write-NWAIT timings	168
Table 97.	Synchronous multiplexed NOR/PSRAM read timings	170
Table 98.	Synchronous multiplexed PSRAM write timings	172
Table 99.	Synchronous non-multiplexed NOR/PSRAM read timings	173
Table 100.	Synchronous non-multiplexed PSRAM write timings	174
Table 101.	Switching characteristics for NAND Flash read cycles	177
Table 102.	Switching characteristics for NAND Flash write cycles	177
Table 103.	SDRAM read timings	178
Table 104.	LPSDR SDRAM read timings	179
Table 105.	SDRAM write timings	180
Table 106.	LPSDR SDRAM write timings	180
Table 107.	Quad-SPI characteristics in SDR mode	181
Table 108.	Quad-SPI characteristics in DDR mode	182
Table 109.	DCMI characteristics	183
Table 110.	LTDC characteristics	184
Table 111.	Dynamic characteristics: SD / MMC characteristics, VDD = 2.7 to 3.6 V	186
Table 112.	Dynamic characteristics: SD / MMC characteristics, VDD = 1.71 to 1.9 V	187
Table 113.	RTC characteristics	187
Table 114.	WLCSP168 - 168-pin, 4.891 x 5.692 mm, 0.4 mm pitch wafer level chip scale package mechanical data	189
Table 115.	UFBGA169 - 169-pin, 7 x 7 mm, 0.50 mm pitch, ultra fine pitch ball grid array package mechanical data	190
Table 116.	LQFP176, 24 x 24 mm, 176-pin low-profile quad flat package mechanical data	192
Table 117.	UFBGA176+25, - 201-ball, 10 x 10 mm, 0.65 mm pitch, ultra fine pitch ball grid array package mechanical data	196
Table 118.	UFBGA176+25 recommended PCB design rules (0.65 mm pitch BGA)	197
Table 119.	LQFP208, 28 x 28 mm, 208-pin low-profile quad flat package mechanical data	198
Table 120.	TFBGA216 - thin fine pitch ball grid array 13 x 13 x 0.8mm package mechanical data	202
Table 121.	Package thermal characteristics	204
Table 122.	Ordering information scheme	205
Table 123.	Limitations depending on the operating power supply range	206
Table 124.	Document revision history	207

List of figures

Figure 1.	Incompatible board design for LQFP176 package	14
Figure 2.	Incompatible board design for LQFP208 package	15
Figure 3.	UFBGA176 port-to-terminal assignment differences	16
Figure 4.	TFBGA216 port-to-terminal assignment differences.	17
Figure 5.	STM32F469xx block diagram	18
Figure 6.	STM32F469xx Multi-AHB matrix	21
Figure 7.	VDDUSB connected to an external independent power supply	27
Figure 8.	Power supply supervisor interconnection with internal reset OFF	28
Figure 9.	PDR_ON control with internal reset OFF	29
Figure 10.	Regulator OFF	31
Figure 11.	Startup in regulator OFF: slow V_{DD} slope - power-down reset risen after V_{CAP_1} , V_{CAP_2} stabilization	32
Figure 12.	Startup in regulator OFF mode: fast V_{DD} slope - power-down reset risen before V_{CAP_1} , V_{CAP_2} stabilization	32
Figure 13.	STM32F46x WLCSP168 pinout	45
Figure 14.	STM32F46x UFBGA169 ballout	46
Figure 15.	STM32F46x UFBGA176 ballout	47
Figure 16.	STM32F46x LQFP176 pinout	48
Figure 17.	STM32F46x LQFP208 pinout	49
Figure 18.	STM32F46x TFBGA216 ballout	50
Figure 19.	Memory map	80
Figure 20.	Pin loading conditions	85
Figure 21.	Pin input voltage	85
Figure 22.	Power supply scheme	86
Figure 23.	Current consumption measurement scheme	87
Figure 24.	External capacitor C_{EXT}	91
Figure 25.	Typical V_{BAT} current consumption (RTC ON / backup SRAM ON and LSE in Low drive mode)	103
Figure 26.	Typical V_{BAT} current consumption (RTC ON / backup SRAM ON and LSE in High drive mode)	104
Figure 27.	High-speed external clock source AC timing diagram	112
Figure 28.	Low-speed external clock source AC timing diagram	112
Figure 29.	Typical application with an 8 MHz crystal	113
Figure 30.	Typical application with a 32.768 kHz crystal	114
Figure 31.	HSI deviation vs. temperature	115
Figure 32.	ACC_{LSI} versus temperature	116
Figure 33.	PLL output clock waveforms in center spread mode	120
Figure 34.	PLL output clock waveforms in down spread mode	120
Figure 35.	MIPI D-PHY HS/LP clock lane transition timing diagram	123
Figure 36.	MIPI D-PHY HS/LP data lane transition timing diagram	123
Figure 37.	FT I/O input characteristics	132
Figure 38.	I/O AC characteristics definition	135
Figure 39.	Recommended NRST pin protection	136
Figure 40.	SPI timing diagram - slave mode and $CPHA = 0$	140
Figure 41.	SPI timing diagram - slave mode and $CPHA = 1^{(1)}$	140
Figure 42.	SPI timing diagram - master mode ⁽¹⁾	141
Figure 43.	I ² S slave timing diagram (Philips protocol) ⁽¹⁾	143
Figure 44.	I ² S master timing diagram (Philips protocol) ⁽¹⁾	143

Figure 45.	SAI master timing waveforms	145
Figure 46.	SAI slave timing waveforms	145
Figure 47.	USB OTG full speed timings: definition of data signal rise and fall time	147
Figure 48.	ULPI timing diagram	148
Figure 49.	Ethernet SMI timing diagram	150
Figure 50.	Ethernet RMII timing diagram	150
Figure 51.	Ethernet MII timing diagram	151
Figure 52.	ADC accuracy characteristics	156
Figure 53.	Typical connection diagram using the ADC	156
Figure 54.	Power supply and reference decoupling (V_{REF+} not connected to V_{DDA})	157
Figure 55.	Power supply and reference decoupling (V_{REF+} connected to V_{DDA})	157
Figure 56.	12-bit buffered/non-buffered DAC	161
Figure 57.	Asynchronous non-multiplexed SRAM/PSRAM/NOR read waveforms	162
Figure 58.	Asynchronous non-multiplexed SRAM/PSRAM/NOR write waveforms	164
Figure 59.	Asynchronous multiplexed PSRAM/NOR read waveforms	165
Figure 60.	Asynchronous multiplexed PSRAM/NOR write waveforms	167
Figure 61.	Synchronous multiplexed NOR/PSRAM read timings	169
Figure 62.	Synchronous multiplexed PSRAM write timings	171
Figure 63.	Synchronous non-multiplexed NOR/PSRAM read timings	173
Figure 64.	Synchronous non-multiplexed PSRAM write timings	174
Figure 65.	NAND controller waveforms for read access	175
Figure 66.	NAND controller waveforms for write access	176
Figure 67.	NAND controller waveforms for common memory read access	176
Figure 68.	NAND controller waveforms for common memory write access	177
Figure 69.	SDRAM read access waveforms (CL = 1)	178
Figure 70.	SDRAM write access waveforms	179
Figure 71.	Quad-SPI SDR timing diagram	181
Figure 72.	Quad-SPI DDR timing diagram	182
Figure 73.	DCMI timing diagram	183
Figure 74.	LCD-TFT horizontal timing diagram	184
Figure 75.	LCD-TFT vertical timing diagram	185
Figure 76.	SDIO high-speed mode	185
Figure 77.	SD default mode	186
Figure 78.	WLCSP168 - 168-pin, 4.891 x 5.692 mm, 0.4 mm pitch wafer level chip scale package outline	188
Figure 79.	UFBGA169 - 169-pin, 7 x 7 mm, 0.50 mm pitch, ultra fine pitch ball grid array package outline	190
Figure 80.	UFBGA169 marking example (package top view)	191
Figure 81.	LQFP176, 24 x 24 mm, 176-pin low-profile quad flat package outline	192
Figure 82.	LQFP176 recommended footprint	194
Figure 83.	LQFP176 marking example (package top view)	195
Figure 84.	UFBGA176+25 - 201-ball, 10 x 10 mm, 0.65 mm pitch, ultra fine pitch ball grid array package outline	196
Figure 85.	UFBGA176+25 - 201-ball, 10 x 10 mm, 0.65 mm pitch, ultra fine pitch ball grid array package recommended footprint	197
Figure 86.	LQFP208, 28 x 28 mm, 208-pin low-profile quad flat package outline	198
Figure 87.	LQFP208 recommended footprint	200
Figure 88.	LQFP208 marking example (package top view)	201
Figure 89.	TFBGA216 - thin fine pitch ball grid array 13 x 13 x 0.8mm, package outline	202
Figure 90.	TFBGA216 marking example (package top view)	203

1 Description

The STM32F469xx devices are based on the high-performance ARM® Cortex®-M4 32-bit RISC core operating at a frequency of up to 180 MHz. The Cortex®-M4 core features a Floating point unit (FPU) single precision which supports all ARM® single-precision data-processing instructions and data types. It also implements a full set of DSP instructions and a memory protection unit (MPU) which enhances application security.

The STM32F469xx devices incorporate high-speed embedded memories (Flash memory up to 2 Mbytes, up to 384 Kbytes of SRAM), up to 4 Kbytes of backup SRAM, and an extensive range of enhanced I/Os and peripherals connected to two APB buses, two AHB buses and a 32-bit multi-AHB bus matrix.

All devices offer three 12-bit ADCs, two DACs, a low-power RTC, twelve general-purpose 16-bit timers including two PWM timers for motor control, two general-purpose 32-bit timers, and a true random number generator (RNG). They also feature standard and advanced communication interfaces:

- Up to three I²Cs
- Six SPIs, two I²Ss full duplex. To achieve audio class accuracy, the I²S peripherals can be clocked via a dedicated internal audio PLL or via an external clock to allow synchronization.
- Four USARTs plus four UARTs
- An USB OTG full-speed and a USB OTG high-speed with full-speed capability (with the ULPI),
- Two CANs
- One SAI serial audio interface
- An SDMMC host interface
- Ethernet and camera interface
- LCD-TFT display controller
- Chrom-ART Accelerator™
- DSI Host.

Advanced peripherals include an SDMMC interface, a flexible memory control (FMC) interface, a Quad-SPI Flash memory, and camera interface for CMOS sensors. Refer to [Table 2](#) for the list of peripherals available on each part number.

The STM32F469xx devices operate in the –40 to +105 °C temperature range from a 1.7 to 3.6 V power supply. A dedicated supply input for USB (OTG_FS and OTG_HS) only in full speed mode, is available on all packages.

The supply voltage can drop to 1.7 V (refer to [Section 2.19.2](#)). A comprehensive set of power-saving mode allows the design of low-power applications.

The STM32F469xx devices are offered in 5 packages, ranging from 168 pins to 216 pins. The set of included peripherals changes with the device chosen, according to [Table 2](#).

These features make the STM32F469xx microcontrollers suitable for a wide range of applications:

- Motor drive and application control
- Medical equipment
- Industrial applications: PLC, inverters, circuit breakers
- Printers, and scanners
- Alarm systems, video intercom, and HVAC
- Home audio appliances

Figure 5 shows the general block diagram of the device family.

Table 2. STM32F469xx features and peripheral counts

Peripherals		STM32F469Ax			STM32F469Ix			STM32F469Bx			STM32F469Nx		
Flash memory in Kbytes		512	1024	2048	512	1024	2048	512	1024	2048	512	1024	2048
SRAM in Kbytes	System	384(160+32+128+64)											
	Backup	4											
FMC memory controller		Yes											
Quad-SPI		Yes											
Ethernet		No			Yes								
Timers	General-purpose	10											
	Advanced-control	2											
	Basic	2											
Random number generator		Yes											
Communication interfaces	SPI / I ² S	6/2(full duplex) ⁽¹⁾											
	I ² C	3											
	USART/UART	4/4											
	USB OTG FS	Yes											
	USB OTG HS	Yes											
	CAN	2											
	SAI	1											
	SDIO	Yes											
Camera interface		Yes											
MIPI-DSI Host		Yes											
LCD-TFT		Yes											
Chrom-ART Accelerator™ (DMA2D)		Yes											
GPIOs		114			131			161			161		

Table 2. STM32F469xx features and peripheral counts (continued)

Peripherals	STM32F469Ax	STM32F469Ix	STM32F469Bx	STM32F469Nx
12-bit ADC Number of channels	3			
	24			
12-bit DAC Number of channels	Yes 2			
Maximum CPU frequency	180 MHz			
Operating voltage	1.7 to 3.6V ⁽²⁾			
Operating temperatures	Ambient operating temperature: -40 to 85 °C / -40 to 105 °C Junction temperature: -40 to 105 °C / -40 to 125 °C			
Package	UFBGA169 WLCSP168	LQFP176 UFBGA176	LQFP208	TFBGA216

1. The SPI2 and SPI3 interfaces give the flexibility to work in an exclusive way in either the SPI mode or the I2S audio mode.
2. VDD/VDDA minimum value of 1.7 V is obtained when the internal reset is OFF (refer to [Section 2.19.2](#)).

1.1 Compatibility throughout the family

STM32F469xx devices are not compatible with other STM32F4xx devices. [Figure 1](#) and [Figure 2](#) show incompatible board designs, respectively, for LQFP176 and LQFP208 packages (highlighted pins). The UFBGA176 and TFBGA216 ballouts are compatible with other STM32F4xx devices, only few IO port pins are substituted, as shown in [Figure 3](#) and [Figure 4](#). The UFBGA169 package is incompatible with other STM32F4xx devices.

1.1.1 LQFP176 package

Figure 1. Incompatible board design for LQFP176 package

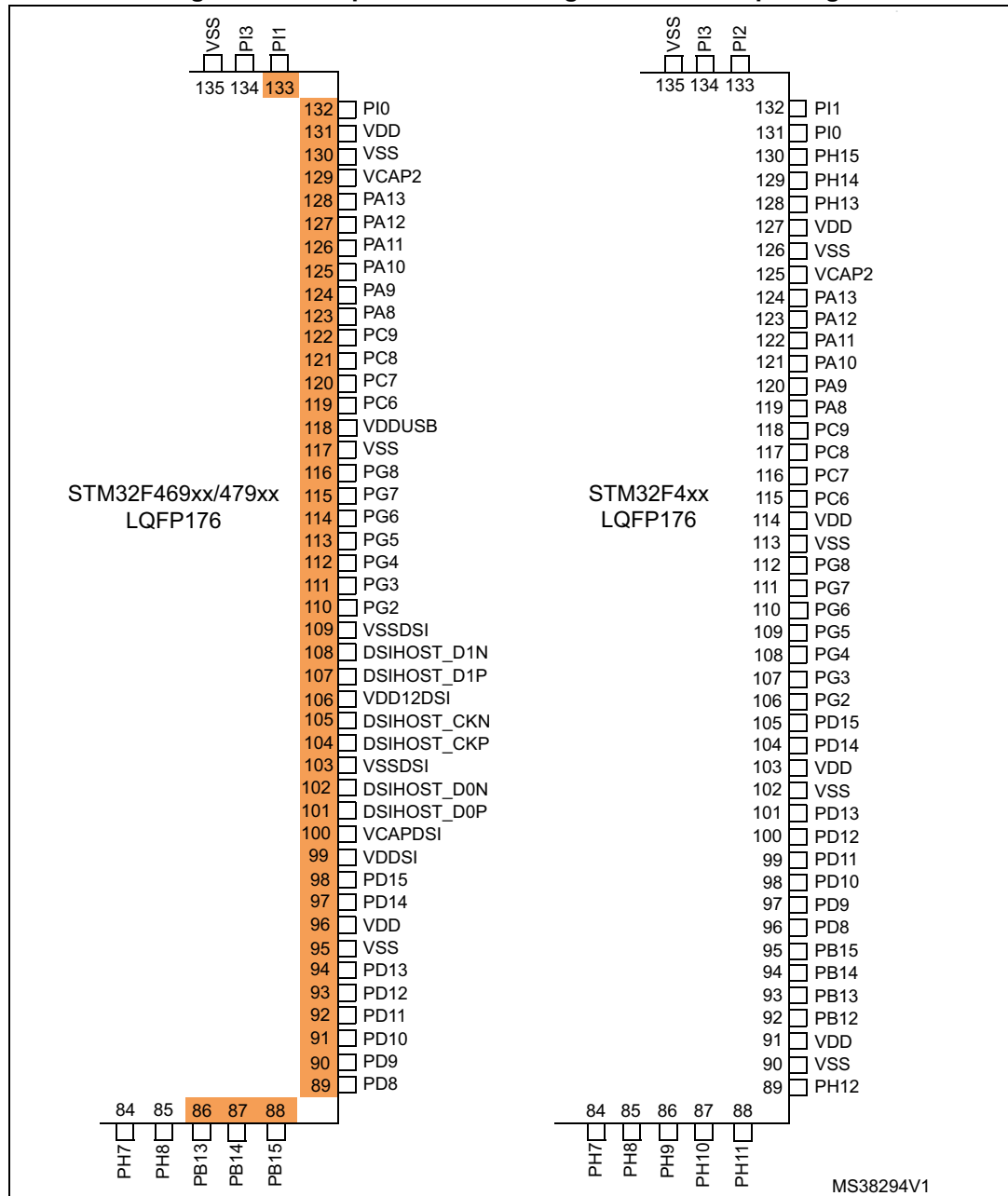

1. Pins from 86 to 133 are not compatible.

1.1.2 LQFP208 package

Figure 2. Incompatible board design for LQFP208 package

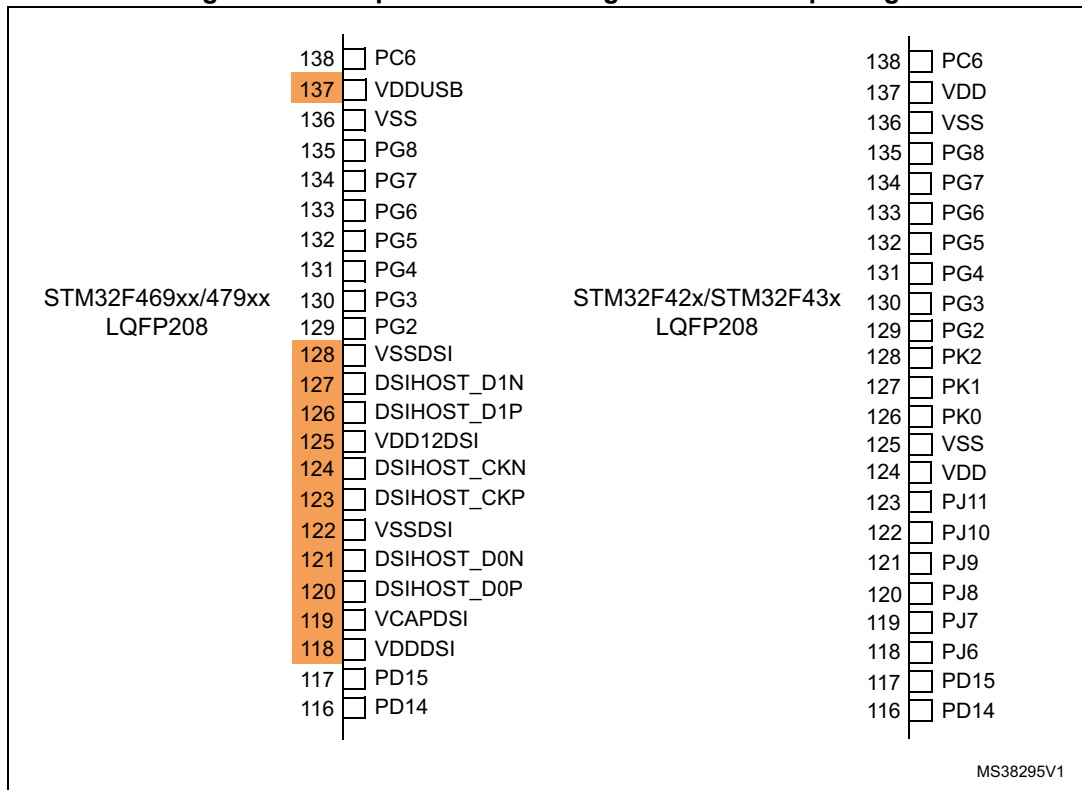

1. Pins from 118 to 128 and pin 137 are not compatible

1.1.4 TFBGA216 package

Figure 4. TFBGA216 port-to-terminal assignment differences

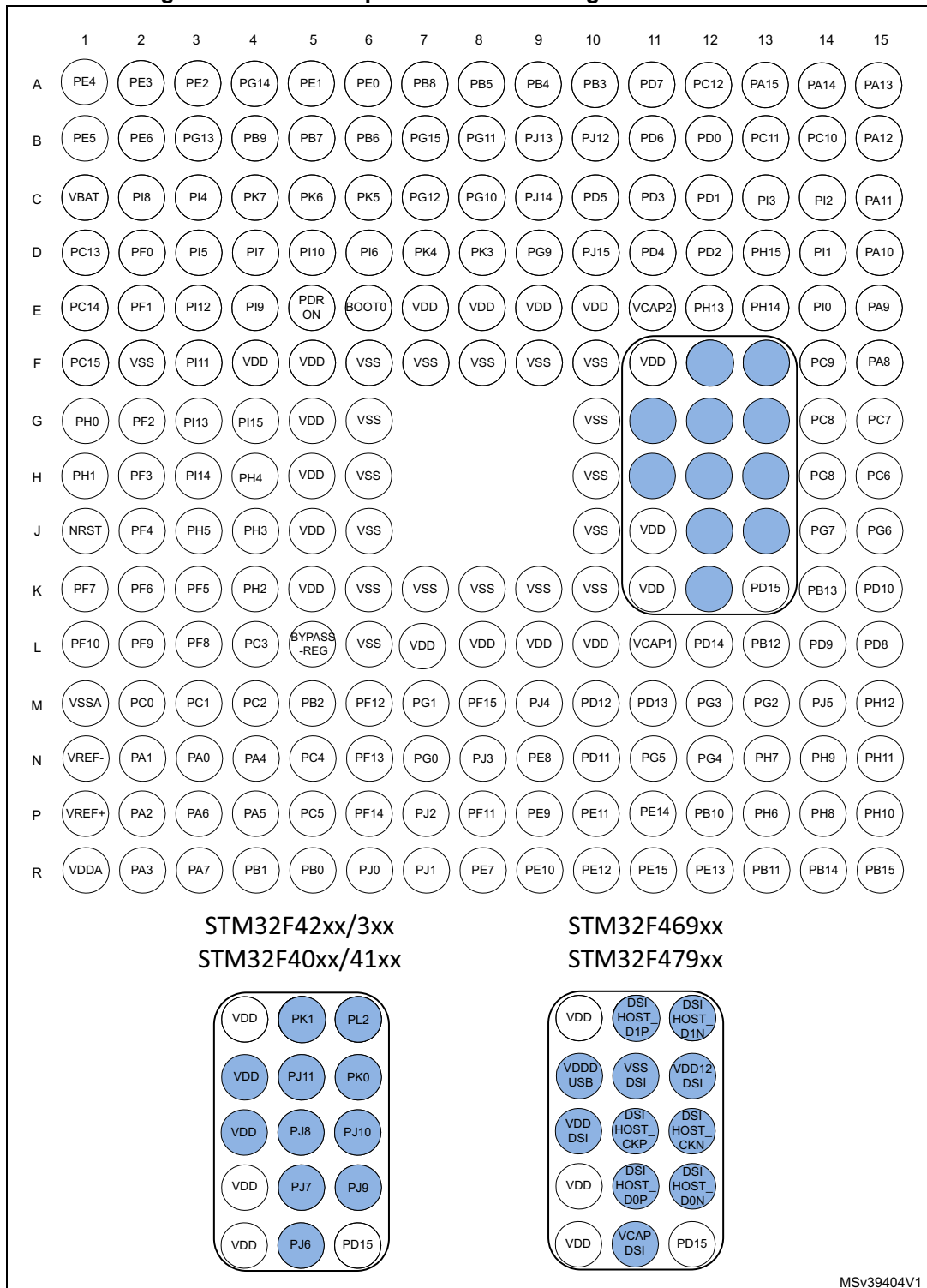

1. The highlighted pins are substituted with dedicated DSI IO pins on STM32F469xx/479xx devices.

Figure 5. STM32F469xx block diagram

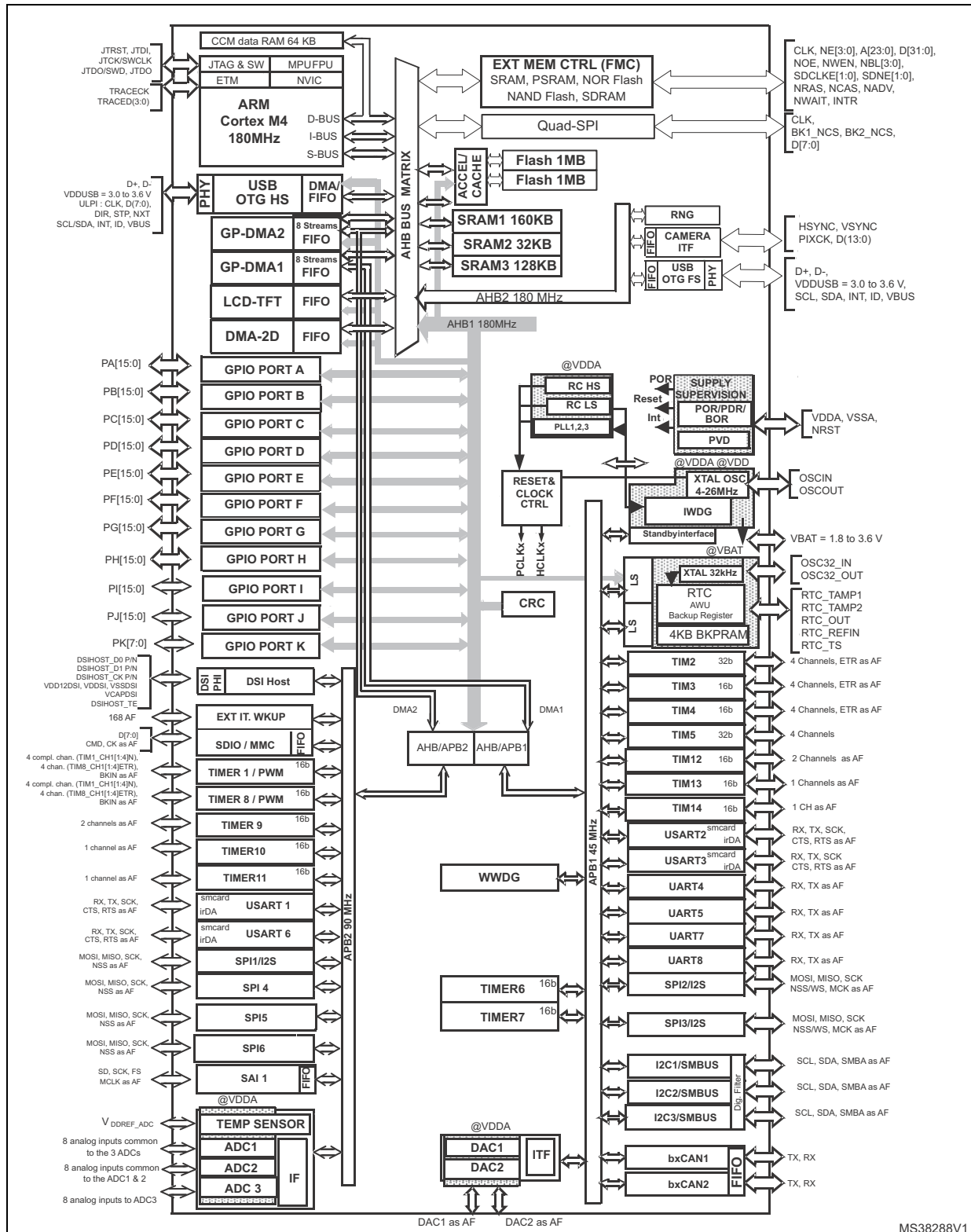

1. The timers connected to APB2 are clocked from TIMxCLK up to 180 MHz, while the timers connected to APB1 are clocked from TIMxCLK either up to 90 MHz or 180 MHz depending on TIMPRE bit configuration in the RCC_DCKCFGR register.

2 Functional overview

2.1 ARM[®] Cortex[®]-M4 with FPU and embedded Flash and SRAM

The ARM[®] Cortex[®]-M4 with FPU processor is the latest generation of ARM processors for embedded systems. It was developed to provide a low-cost platform that meets the needs of MCU implementation, with a reduced pin count and low-power consumption, while delivering outstanding computational performance and an advanced response to interrupts.

The ARM[®] Cortex[®]-M4 with FPU core is a 32-bit RISC processor that features exceptional code-efficiency, delivering the high-performance expected from an ARM core in the memory size usually associated with 8- and 16-bit devices.

The processor supports a set of DSP instructions which allow efficient signal processing and complex algorithm execution.

Its single precision FPU (floating point unit) speeds up software development by using metalanguage development tools, while avoiding saturation.

The STM32F46x line is compatible with all ARM tools and software.

Figure 5 shows the general block diagram of the STM32F46x line.

Note: Cortex[®]-M4 with FPU core is binary compatible with the Cortex[®]-M3 core.

2.2 Adaptive real-time memory accelerator (ART Accelerator™)

The ART Accelerator™ is a memory accelerator optimized for STM32 industry-standard ARM[®] Cortex[®]-M4 with FPU processors. It balances the inherent performance advantage of the ARM[®] Cortex[®]-M4 with FPU over Flash memory technologies, which normally require the processor to wait for the Flash memory at higher frequencies.

To release the processor full 225 DMIPS performance at this frequency, the accelerator implements an instruction prefetch queue and branch cache, which increases program execution speed from the 128-bit Flash memory. Based on CoreMark[®] benchmark, the performance achieved thanks to the ART Accelerator is equivalent to 0 wait state program execution from Flash memory at a CPU frequency up to 180 MHz.

2.3 Memory protection unit

The memory protection unit (MPU) is used to manage the CPU accesses to memory to prevent one task to accidentally corrupt the memory or resources used by any other active task. This memory area is organized into up to 8 protected areas that can in turn be divided up into 8 subareas. The protection area sizes are between 32 bytes and the whole 4 gigabytes of addressable memory.

The MPU is especially helpful for applications where some critical or certified code has to be protected against the misbehavior of other tasks. It is usually managed by an RTOS (real-time operating system). If a program accesses a memory location that is prohibited by the MPU, the RTOS can detect it and take action. In an RTOS environment, the kernel can dynamically update the MPU area setting, based on the process to be executed.

The MPU is optional and can be bypassed for applications that do not need it.

2.4 Embedded Flash memory

The devices embed a Flash memory of up to 2 Mbytes available for storing programs and data.

2.5 CRC (cyclic redundancy check) calculation unit

The CRC (cyclic redundancy check) calculation unit is used to get a CRC code from a 32-bit data word and a fixed generator polynomial.

Among other applications, CRC-based techniques are used to verify data transmission or storage integrity. In the scope of the EN/IEC 60335-1 standard, they offer a means of verifying the Flash memory integrity. The CRC calculation unit helps compute a software signature during runtime, to be compared with a reference signature generated at link-time and stored at a given memory location.

2.6 Embedded SRAM

All devices embed:

- Up to 384Kbytes of system SRAM including 64 Kbytes of CCM (core coupled memory) data RAM
RAM memory is accessed (read/write) at CPU clock speed with 0 wait states.
- 4 Kbytes of backup SRAM
This area is accessible only from the CPU. Its content is protected against possible unwanted write accesses, and is retained in Standby or VBAT mode.

2.7 Multi-AHB bus matrix

The 32-bit multi-AHB bus matrix interconnects all the masters (CPU, DMAs, Ethernet, USB HS, LCD-TFT, and DMA2D) and the slaves (Flash memory, RAM, FMC, QUADSPI, AHB and APB peripherals) and ensures a seamless and efficient operation even when several high-speed peripherals work simultaneously.

Figure 6. STM32F469xx Multi-AHB matrix

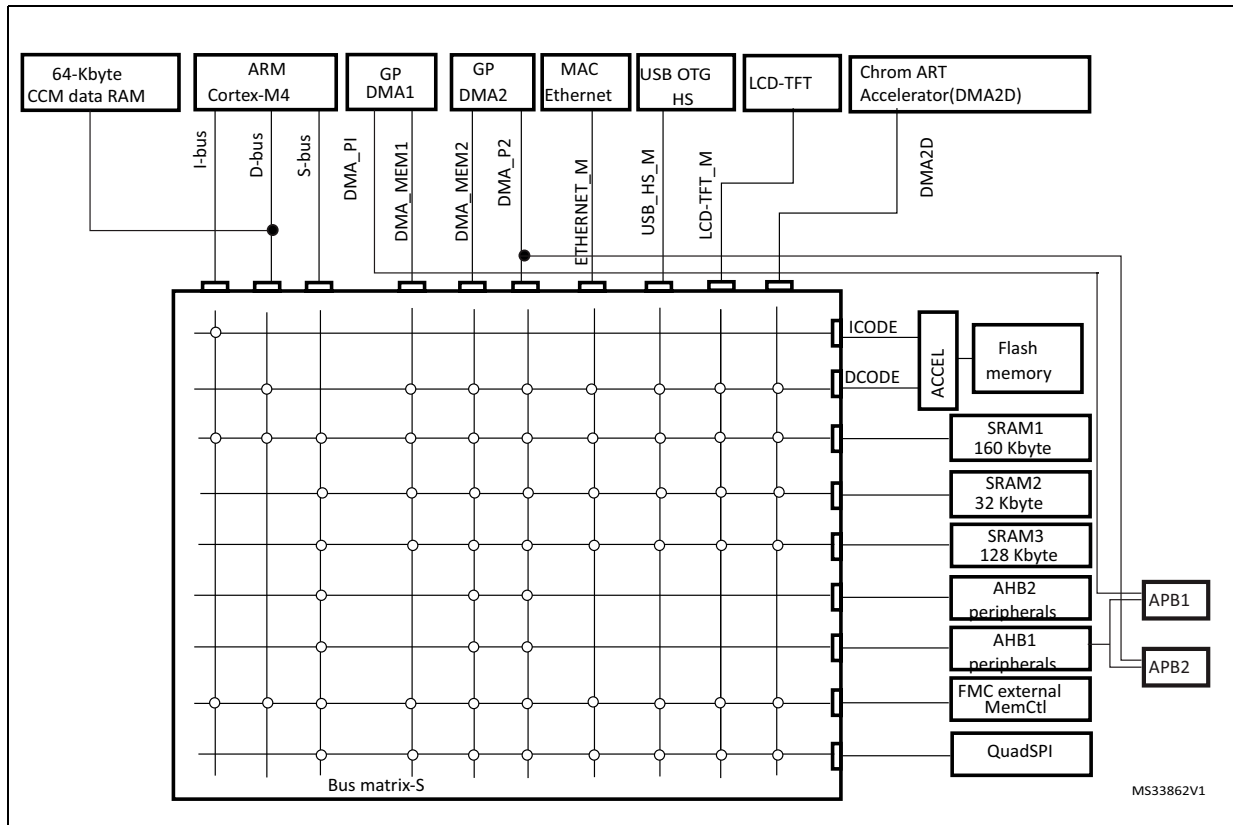

2.8 DMA controller (DMA)

The devices feature two general-purpose dual-port DMAs (DMA1 and DMA2) with 8 streams each. They are able to manage memory-to-memory, peripheral-to-memory and memory-to-peripheral transfers. They feature dedicated FIFOs for APB/AHB peripherals, support burst transfer and are designed to provide the maximum peripheral bandwidth (AHB/APB).

The two DMA controllers support circular buffer management, so that no specific code is needed when the controller reaches the end of the buffer. The two DMA controllers also have a double buffering feature, which automates the use and switching of two memory buffers without requiring any special code.

Each stream is connected to dedicated hardware DMA requests, with support for software trigger on each stream. Configuration is made by software and transfer sizes between source and destination are independent.

The DMA can be used with the main peripherals:

- SPI and I²S
- I²C
- USART
- General-purpose, basic and advanced-control timers TIMx
- DAC
- SDIO
- Camera interface (DCMI)
- ADC
- SAI1
- QUADSPI.

2.9 Flexible Memory Controller (FMC)

The Flexible memory controller (FMC) includes three memory controllers:

- The NOR/PSRAM memory controller
- The NAND/memory controller
- The Synchronous DRAM (SDRAM/Mobile LPDDR SDRAM) controller

The main features of the FMC controller are the following:

- Interface with static-memory mapped devices including:
 - Static random access memory (SRAM)
 - NOR Flash memory/OneNAND Flash memory
 - PSRAM
 - NAND Flash memory with ECC hardware to check up to 8 Kbytes of data
- Interface with synchronous DRAM (SDRAM/Mobile LPDDR SDRAM) memories
- 8-, 16-, 32-bit data bus width
- Independent Chip Select control for each memory bank
- Independent configuration for each memory bank
- Write FIFO
- Read FIFO for SDRAM controller
- The Maximum FMC_CLK/FMC_SDCLK frequency for synchronous accesses is HCLK/2.

LCD parallel interface

The FMC can be configured to interface seamlessly with most graphic LCD controllers. It supports the Intel 8080 and Motorola 6800 modes, and is flexible enough to adapt to specific LCD interfaces. This LCD parallel interface capability makes it easy to build cost effective graphic applications using LCD modules with embedded controllers or high performance solutions using external controllers with dedicated acceleration.

2.10 Quad-SPI memory interface (QUADSPI)

All STM32F469xx devices embeds a Quad-SPI memory interface, which is a specialized communication interface targeting Single, Dual, Quad or Dual-flash SPI memories. It can work in direct mode through registers, external flash status register polling mode and memory mapped mode. Up to 256 Mbytes external Flash memory are mapped, supporting 8, 16 and 32-bit access. Code execution is supported.

The opcode and the frame format are fully programmable. Communication can be either in Single Data Rate or Dual Data Rate.

2.11 LCD-TFT controller

The LCD-TFT display controller provides a 24-bit parallel digital RGB (Red, Green, Blue) and delivers all signals to interface directly to a broad range of LCD and TFT panels up to XGA (1024x768) resolution with the following features:

- 2 displays layers with dedicated FIFO (64x32-bit)
- Color Look-Up table (CLUT) up to 256 colors (256x24-bit) per layer
- Up to 8 Input color formats selectable per layer
- Flexible blending between two layers using alpha value (per pixel or constant)
- Flexible programmable parameters for each layer
- Color keying (transparency color)
- Up to 4 programmable interrupt events.

2.12 DSI Host (DSIHOST)

The DSI Host is a dedicated peripheral for interfacing with MIPI[®] DSI compliant displays. It includes a dedicated video interface internally connected to the LTDC and a generic APB interface that can be used to transmit information to the display.

These interfaces are as follows:

- LTDC interface:
 - Used to transmit information in Video Mode, in which the transfers from the host processor to the peripheral take the form of a real-time pixel stream (DPI).
 - Through a customized for mode, this interface can be used to transmit information in full bandwidth in the Adapted Command Mode (DBI).
- APB slave interface:
 - Allows the transmission of generic information in Command mode, and follows a proprietary register interface.
 - Can operate concurrently with either LTDC interface in either Video Mode or Adapted Command Mode.
- Video mode pattern generator:
 - Allows the transmission of horizontal/vertical color bar and D-PHY BER testing pattern without any kind of stimuli.

The DSI Host main features:

- Compliant with MIPI[®] Alliance standards
- Interface with MIPI[®] D-PHY
- Supports all commands defined in the MIPI[®] Alliance specification for DCS:
 - Transmission of all Command mode packets through the APB interface
 - Transmission of commands in low-power and high-speed during Video Mode
- Supports up to two D-PHY data lanes
- Bidirectional communication and escape mode support through data lane 0
- Supports non-continuous clock in D-PHY clock lane for additional power saving
- Supports Ultra Low-Power mode with PLL disabled
- ECC and Checksum capabilities
- Support for End of Transmission Packet (EoTp)
- Fault recovery schemes
- 3D transmission support
- Configurable selection of system interfaces:
 - AMBA APB for control and optional support for Generic and DCS commands
 - Video Mode interface through LTDC
 - Adapted Command Mode interface through LTDC
- Independently programmable Virtual Channel ID in
 - Video Mode
 - Adapted Command Mode
 - APB Slave

Video Mode interfaces features:

- LTDC interface color coding mappings into 24-bit interface:
 - 16-bit RGB, configurations 1, 2, and 3
 - 18-bit RGB, configurations 1 and 2
 - 24-bit RGB
- Programmable polarity of all LTDC interface signals
- Extended resolutions beyond the DPI standard maximum resolution of 800x480 pixels: maximum resolution is limited by available DSI physical link bandwidth:
 - Number of lanes: 2
 - Maximum speed per lane: 500Mbps

Adapted interface features:

- Support for sending large amounts of data through the *memory_write_start* (WMS) and *memory_write_continue* (WMC) DCS commands
- LTDC interface color coding mappings into 24-bit interface:
 - 16-bit RGB, configurations 1, 2, and 3
 - 18-bit RGB, configurations 1 and 2
 - 24-bit RGB

Video mode pattern generator:

- Vertical and horizontal color bar generation without LTDC stimuli
- BER pattern without LTDC stimuli

2.13 Chrom-Art Accelerator™ (DMA2D)

The Chrom-Art Accelerator™ (DMA2D) is a graphic accelerator which offers advanced bit blitting, row data copy and pixel format conversion. It supports the following functions:

- Rectangle filling with a fixed color
- Rectangle copy
- Rectangle copy with pixel format conversion
- Rectangle composition with blending and pixel format conversion.

Various image format coding are supported, from indirect 4bpp color mode up to 32bpp direct color. It embeds dedicated memory to store color lookup tables.

An interrupt can be generated when an operation is complete or at a programmed watermark.

All the operations are fully automatized and are running independently from the CPU or the DMAs.

2.14 Nested vectored interrupt controller (NVIC)

The devices embed a nested vectored interrupt controller able to manage 16 priority levels, and handle up to 93 maskable interrupt channels plus the 16 interrupt lines of the Cortex®-M4 with FPU core.

- Closely coupled NVIC gives low-latency interrupt processing
- Interrupt entry vector table address passed directly to the core
- Allows early processing of interrupts
- Processing of late arriving, higher-priority interrupts
- Support tail chaining
- Processor state automatically saved
- Interrupt entry restored on interrupt exit with no instruction overhead

This hardware block provides flexible interrupt management features with minimum interrupt latency.

2.15 External interrupt/event controller (EXTI)

The external interrupt/event controller consists of 23 edge-detector lines used to generate interrupt/event requests. Each line can be independently configured to select the trigger event (rising edge, falling edge, both) and can be masked independently. A pending register maintains the status of the interrupt requests. The EXTI can detect an external line with a pulse width shorter than the Internal APB2 clock period. Up to 159 GPIOs can be connected to the 16 external interrupt lines.

2.16 Clocks and startup

On reset the 16 MHz internal RC oscillator is selected as the default CPU clock. The 16 MHz internal RC oscillator is factory-trimmed to offer 1% accuracy over the full temperature range. The application can then select as system clock either the RC oscillator or an external 4-26 MHz clock source. This clock can be monitored for failure. If a failure is detected, the system automatically switches back to the internal RC oscillator and a software interrupt is generated (if enabled). This clock source is input to a PLL thus allowing to increase the frequency up to 180 MHz. Similarly, full interrupt management of the PLL clock entry is available when necessary (for example if an indirectly used external oscillator fails).

Several prescalers allow the configuration of the two AHB buses, the high-speed APB (APB2) and the low-speed APB (APB1) domains. The maximum frequency of the two AHB buses is 180 MHz while the maximum frequency of the high-speed APB domains is 90 MHz. The maximum allowed frequency of the low-speed APB domain is 45 MHz.

The devices embed a dedicated PLL (PLL12S) and PLLSAI which allows to achieve audio class performance. In this case, the I²S master clock can generate all standard sampling frequencies from 8 kHz to 192 kHz.

2.17 Boot modes

At startup, boot pins are used to select one out of three boot options:

- Boot from user Flash
- Boot from system memory
- Boot from embedded SRAM

The boot loader is located in system memory. It is used to reprogram the Flash memory through a serial interface. Refer to application note AN2606 for details.

2.18 Power supply schemes

- $V_{DD} = 1.7$ to 3.6 V: external power supply for I/Os and the internal regulator (when enabled), provided externally through V_{DD} pins.
- $V_{SSA}, V_{DDA} = 1.7$ to 3.6 V: external analog power supplies for ADC, DAC, Reset blocks, RCs and PLL. V_{DDA} and V_{SSA} must be connected to V_{DD} and V_{SS} , respectively.

Note: V_{DD}/V_{DDA} minimum value of 1.7 V is obtained when the internal reset is OFF (refer to [Section 2.19.2](#)). Refer to [Table 3](#) to identify the packages supporting this option.

- $V_{BAT} = 1.65$ to 3.6 V: power supply for RTC, external clock 32 kHz oscillator and backup registers (through power switch) when V_{DD} is not present.
- V_{DDUSB} can be connected either to V_{DD} or an external independent power supply (3.0 to 3.6V) for USB transceivers.

For example, when device is powered at 1.8V, an independent power supply 3.3V can be connected to V_{DDUSB} . When the V_{DDUSB} is connected to a separated power supply, it is independent from V_{DD} or V_{DDA} but it must be the last supply to be provided and the first to disappear.

The following conditions must be respected:

- During power-on phase ($V_{DD} < V_{DD_MIN}$), V_{DDUSB} should be always lower than V_{DD}
- During power-down phase ($V_{DD} < V_{DD_MIN}$), V_{DDUSB} should be always lower than V_{DD}
- V_{DDUSB} rising and falling time rate specifications must be respected.
- In operating mode phase, V_{DDUSB} could be lower or higher than V_{DD} :
 - If USB (USB OTG_HS/OTG_FS) is used, the associated GPIOs powered by V_{DDUSB} are operating between V_{DDUSB_MIN} and V_{DDUSB_MAX} . The V_{DDUSB} supplies both USB transceivers (USB OTG_HS and USB OTG_FS).
 - If only one USB transceiver is used in the application, the GPIOs associated to the other USB transceiver are still supplied by V_{DDUSB} .
 - If USB (USB OTG_HS/OTG_FS) is not used, the associated GPIOs powered by V_{DDUSB} are operating between V_{DD_MIN} and V_{DD_MAX} .

Figure 7. V_{DDUSB} connected to an external independent power supply

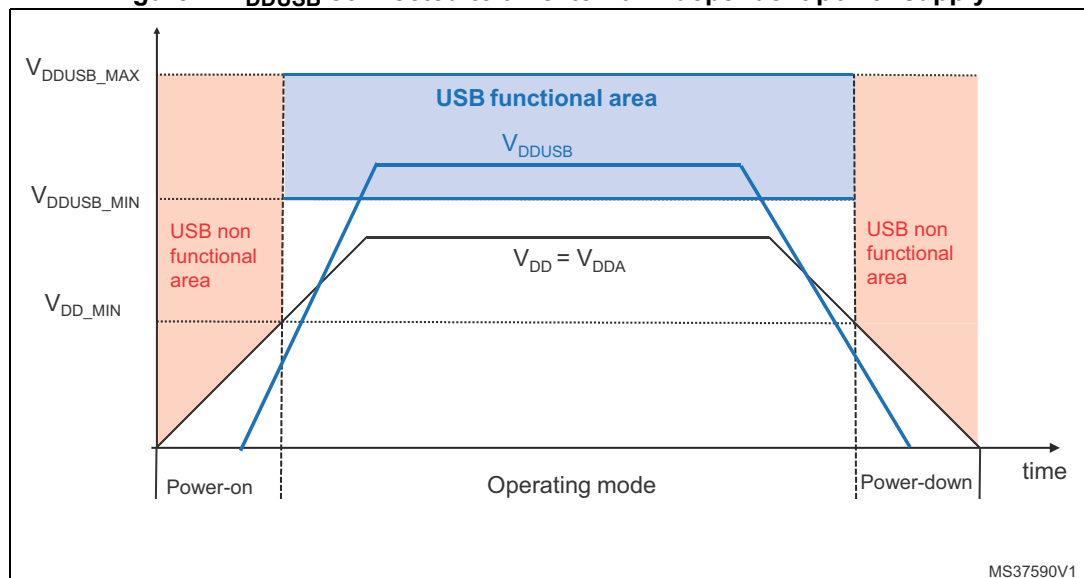

The DSI (Display Serial Interface) sub-system uses several power supply pins which are independent from the other supply pins:

- VDDDSI is an independent DSI power supply dedicated for DSI Regulator and MIPI D-PHY. This supply must be connected to global VDD.
- VCAPDSI pin is the output of DSI Regulator (1.2V) which must be connected externally to VDD12DSI.
- VDD12DSI pin is used to supply the MIPI D-PHY, and to supply clock and data lanes pins. An external capacitor of 2.2 μ F must be connected on VDD12DSI pin.
- VSSDSI pin is an isolated supply ground used for DSI sub-system.
- If DSI functionality is not used at all, then:
 - VDDDSI pin must be connected to global VDD.
 - VCAPDSI pin must be connected externally to VDD12DSI but the external capacitor is no more needed.
 - VSSDSI pin must be grounded.

2.19 Power supply supervisor

2.19.1 Internal reset ON

On packages embedding the PDR_ON pin, the power supply supervisor is enabled by holding PDR_ON high. On the other package, the power supply supervisor is always enabled.

The device has an integrated power-on reset (POR)/ power-down reset (PDR) circuitry coupled with a Brownout reset (BOR) circuitry. At power-on, POR/PDR is always active and ensures proper operation starting from 1.8 V. After the 1.8 V POR threshold level is reached, the option byte loading process starts, either to confirm or modify default BOR thresholds, or to disable BOR permanently. Three BOR thresholds are available through option bytes. The device remains in reset mode when V_{DD} is below a specified threshold, $V_{POR/PDR}$ or V_{BOR} , without the need for an external reset circuit.

The device also features an embedded programmable voltage detector (PVD) that monitors the V_{DD}/V_{DDA} power supply and compares it to the V_{PVD} threshold. An interrupt can be generated when V_{DD}/V_{DDA} drops below the V_{PVD} threshold and/or when V_{DD}/V_{DDA} is higher than the V_{PVD} threshold. The interrupt service routine can then generate a warning message and/or put the MCU into a safe state. The PVD is enabled by software.

2.19.2 Internal reset OFF

This feature is available only on packages featuring the PDR_ON pin. The internal power-on reset (POR) / power-down reset (PDR) circuitry is disabled through the PDR_ON pin.

An external power supply supervisor should monitor V_{DD} and NRST and should maintain the device in reset mode as long as V_{DD} is below a specified threshold. PDR_ON must be connected to VSS, as shown in [Figure 8](#).

Figure 8. Power supply supervisor interconnection with internal reset OFF

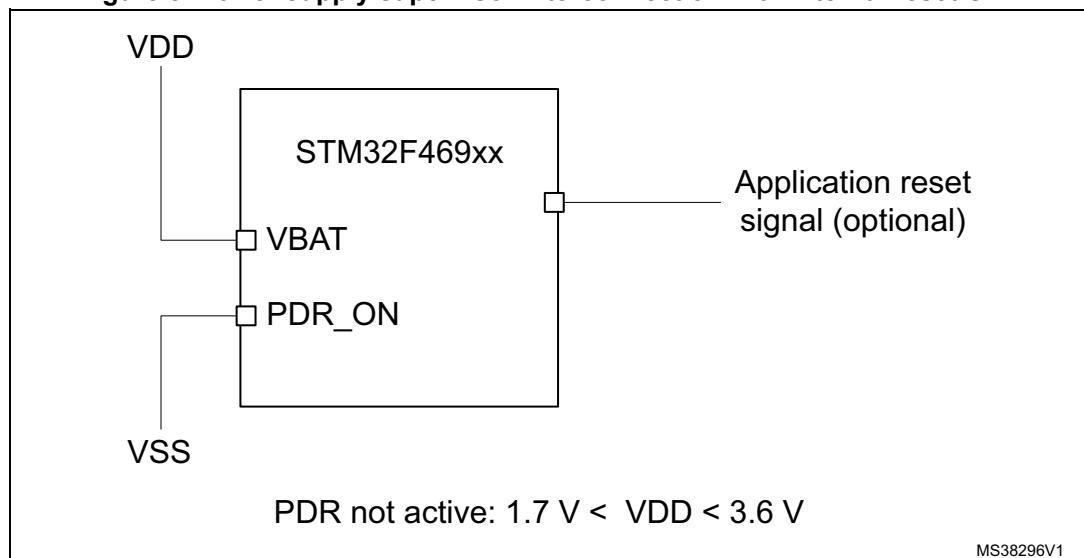

The V_{DD} specified threshold, below which the device must be maintained under reset, is 1.7 V (see [Figure 9](#)).

A comprehensive set of power-saving mode allows to design low-power applications.

When the internal reset is OFF, the following integrated features are no more supported:

- The integrated power-on reset (POR) / power-down reset (PDR) circuitry is disabled
- The brownout reset (BOR) circuitry must be disabled
- The embedded programmable voltage detector (PVD) is disabled
- V_{BAT} functionality is no more available and V_{BAT} pin should be connected to V_{DD} .

All packages allow to disable the internal reset through the PDR_ON signal when connected to VSS.

Figure 9. PDR_ON control with internal reset OFF

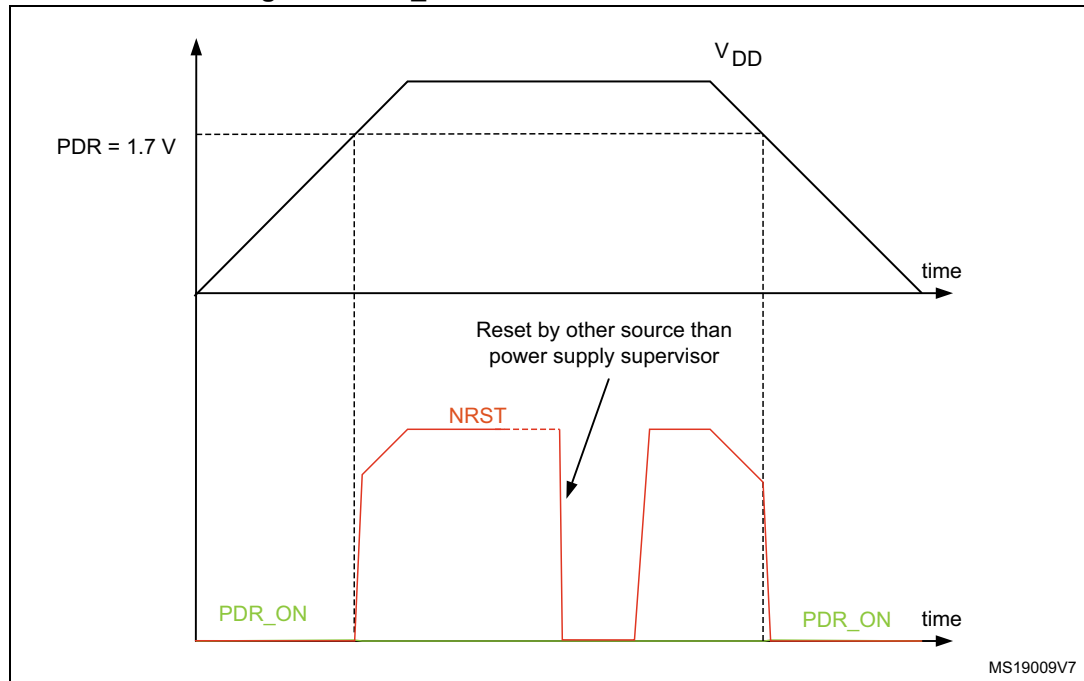

1. PDR_ON signal to be kept always low.

2.20 Voltage regulator

The regulator has four operating modes:

- Regulator ON
 - Main regulator mode (MR)
 - Low power regulator (LPR)
 - Power-down
- Regulator OFF

2.20.1 Regulator ON

On packages embedding the BYPASS_REG pin, the regulator is enabled by holding BYPASS_REG low. On all other packages, the regulator is always enabled.

There are three power modes configured by software when the regulator is ON:

- MR mode used in Run/sleep modes or in Stop modes
 - In Run/Sleep mode

The MR mode is used either in the normal mode (default mode) or the over-drive mode (enabled by software). Different voltages scaling are provided to reach the best compromise between maximum frequency and dynamic power consumption. The over-drive mode allows operating at a higher frequency than the normal mode for a given voltage scaling.
 - In Stop modes

The MR can be configured in two ways during stop mode:
 MR operates in normal mode (default mode of MR in stop mode)
 MR operates in under-drive mode (reduced leakage mode).
- LPR is used in the Stop modes:

The LP regulator mode is configured by software when entering Stop mode. Like the MR mode, the LPR can be configured in two ways during stop mode:

 - LPR operates in normal mode (default mode when LPR is ON)
 - LPR operates in under-drive mode (reduced leakage mode).
- Power-down is used in Standby mode.

The Power-down mode is activated only when entering in Standby mode. The regulator output is in high impedance and the kernel circuitry is powered down, inducing zero consumption. The contents of the registers and SRAM are lost.

Refer to [Table 3](#) for a summary of voltage regulator modes versus device operating modes.

Two external ceramic capacitors should be connected on V_{CAP_1} and V_{CAP_2} pin. Refer to [Section 2.18](#) and [Table 123](#).

All packages have the regulator ON feature.

Table 3. Voltage regulator configuration mode versus device operating mode⁽¹⁾

Voltage regulator configuration	Run mode	Sleep mode	Stop mode	Standby mode
Normal mode	MR	MR	MR or LPR	-
Over-drive mode ⁽²⁾	MR	MR	-	-
Under-drive mode	-	-	MR or LPR	-
Power-down mode	-	-	-	Yes

1. '-' means that the corresponding configuration is not available.
 2. The over-drive mode is not available when V_{DD} = 1.7 to 2.1 V.

2.20.2 Regulator OFF

This feature is available only on packages featuring the BYPASS_REG pin. The regulator is disabled by holding BYPASS_REG high. The regulator OFF mode allows to supply externally a V₁₂ voltage source through V_{CAP_1} and V_{CAP_2} pins.

Since the internal voltage scaling is not managed internally, the external voltage value must be aligned with the targeted maximum frequency. Refer to [Operating conditions](#). The two 2.2 μF ceramic capacitors should be replaced by two 100 nF decoupling capacitors. Refer to [Section 2.18](#).

When the regulator is OFF, there is no more internal monitoring on V_{12} . An external power supply supervisor should be used to monitor the V_{12} of the logic power domain. PA0 pin should be used for this purpose, and act as power-on reset on V_{12} power domain.

In regulator OFF mode, the following features are no more supported:

- PA0 cannot be used as a GPIO pin since it allows to reset a part of the V_{12} logic power domain which is not reset by the NRST pin.
- As long as PA0 is kept low, the debug mode cannot be used under power-on reset. As a consequence, PA0 and NRST pins must be managed separately if the debug connection under reset or pre-reset is required.
- The over-drive and under-drive modes are not available.
- The Standby mode is not available.

Figure 10. Regulator OFF

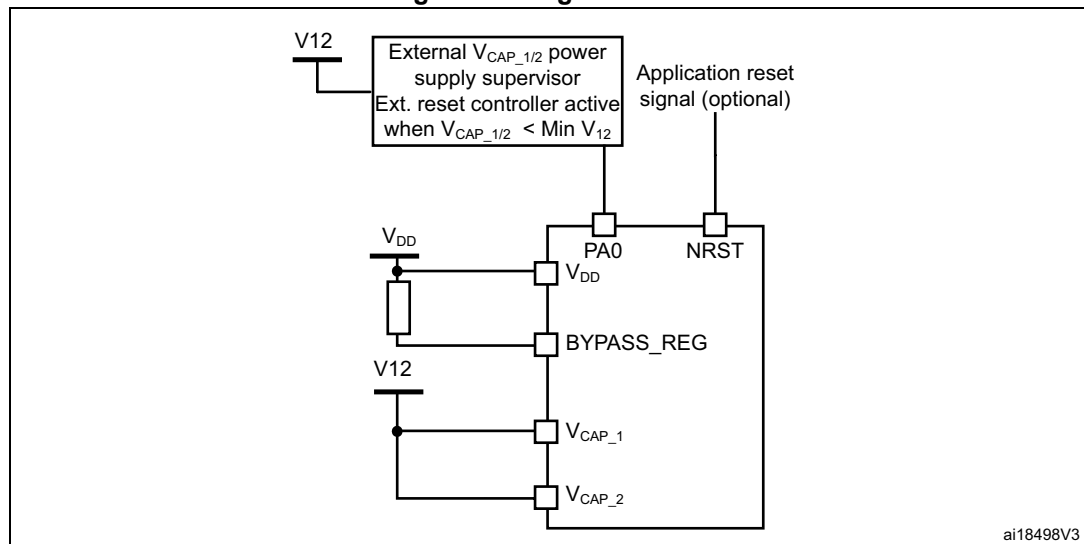

The following conditions must be respected:

- V_{DD} should always be higher than V_{CAP_1} and V_{CAP_2} to avoid current injection between power domains.
- If the time for V_{CAP_1} and V_{CAP_2} to reach V_{12} minimum value is faster than the time for V_{DD} to reach 1.7 V, then PA0 should be kept low to cover both conditions: until V_{CAP_1} and V_{CAP_2} reach V_{12} minimum value and until V_{DD} reaches 1.7 V (see [Figure 11](#)).
- Otherwise, if the time for V_{CAP_1} and V_{CAP_2} to reach V_{12} minimum value is slower than the time for V_{DD} to reach 1.7 V, then $\overline{\text{PA0}}$ could be asserted low externally (see [Figure 12](#)).
- If V_{CAP_1} and V_{CAP_2} go below V_{12} minimum value and V_{DD} is higher than 1.7 V, then a reset must be asserted on PA0 pin.

Note: The minimum value of V_{12} depends on the maximum frequency targeted in the application (see [Operating conditions](#)).

Figure 11. Startup in regulator OFF: slow V_{DD} slope - power-down reset risen after V_{CAP_1} , V_{CAP_2} stabilization

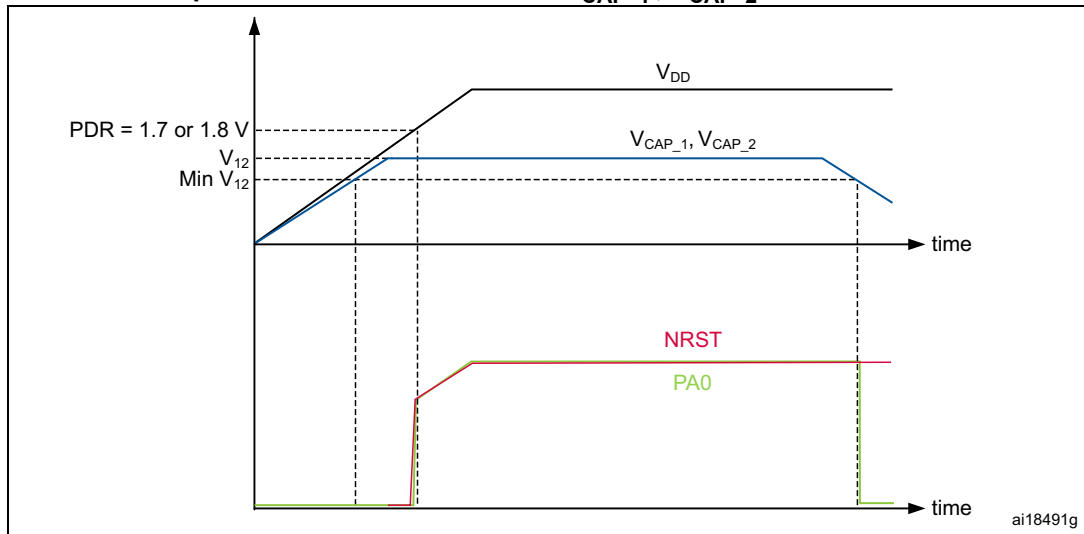

1. This figure is valid whatever the internal reset mode (ON or OFF).

Figure 12. Startup in regulator OFF mode: fast V_{DD} slope - power-down reset risen before V_{CAP_1} , V_{CAP_2} stabilization

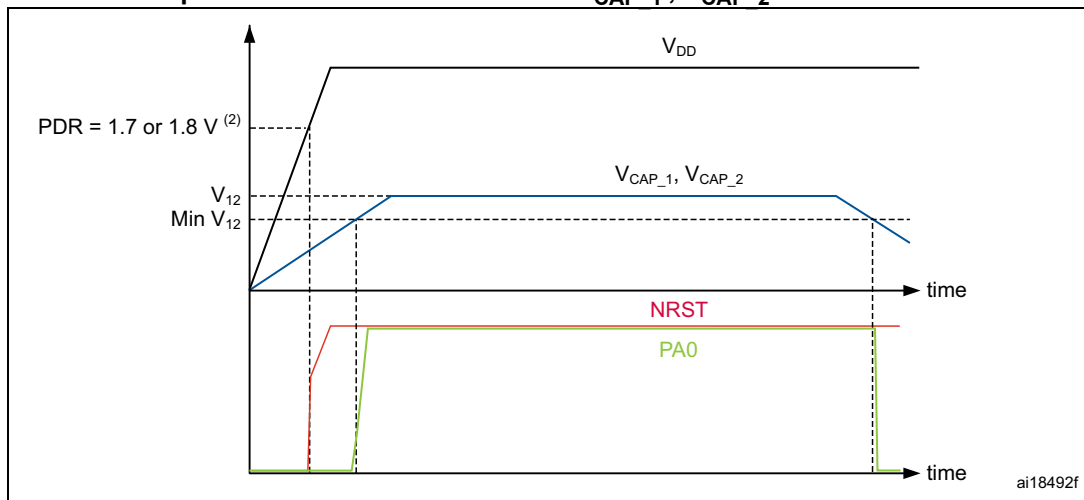

1. This figure is valid whatever the internal reset mode (ON or OFF).

2.20.3 Regulator ON/OFF and internal reset ON/OFF availability

Table 4. Regulator ON/OFF and internal reset ON/OFF availability

Package	Regulator ON	Regulator OFF	Internal reset ON	Internal reset OFF
WLCSP168 UFBGA169 LQFP208	Yes	No	Yes	Yes
LQFP176 UFBGA176 TFBGA216	Yes BYPASS_REG set to V_{SS}	Yes BYPASS_REG set to V_{DD}	PDR_ON set to V_{DD}	PDR_ON set to V_{SS}

2.21 Real-time clock (RTC), backup SRAM and backup registers

The backup domain includes:

- The real-time clock (RTC)
- 4 Kbytes of backup SRAM
- 20 backup registers

The real-time clock (RTC) is an independent BCD timer/counter. Dedicated registers contain the second, minute, hour (in 12/24 hour), week day, date, month, year, in BCD (binary-coded decimal) format. Correction for 28, 29 (leap year), 30, and 31 day of the month are performed automatically. The RTC provides a programmable alarm and programmable periodic interrupts with wakeup from Stop and Standby modes. The sub-seconds value is also available in binary format.

It is clocked by a 32.768 kHz external crystal, resonator or oscillator, the internal low-power RC oscillator or the high-speed external clock divided by 128. The internal low-speed RC has a typical frequency of 32 kHz. The RTC can be calibrated using an external 512 Hz output to compensate for any natural quartz deviation.

Two alarm registers are used to generate an alarm at a specific time and calendar fields can be independently masked for alarm comparison. To generate a periodic interrupt, a 16-bit programmable binary auto-reload downcounter with programmable resolution is available and allows automatic wakeup and periodic alarms from every 120 μ s to every 36 hours.

A 20-bit prescaler is used for the time base clock. It is by default configured to generate a time base of 1 second from a clock at 32.768 kHz.

The 4-Kbyte backup SRAM is an EEPROM-like memory area. It can be used to store data which need to be retained in VBAT and standby mode. This memory area is disabled by default to minimize power consumption (see [Section 2.22](#)). It can be enabled by software.

The backup registers are 32-bit registers used to store 80 bytes of user application data when V_{DD} power is not present. Backup registers are not reset by a system, a power reset, or when the device wakes up from the Standby mode (see [Section 2.22](#)).

Additional 32-bit registers contain the programmable alarm subseconds, seconds, minutes, hours, day, and date.

Like backup SRAM, the RTC and backup registers are supplied through a switch that is powered either from the V_{DD} supply when present or from the V_{BAT} pin.

2.22 Low-power modes

The devices support three low-power modes to achieve the best compromise between low power consumption, short startup time and available wakeup sources:

- **Sleep mode**

In Sleep mode, only the CPU is stopped. All peripherals continue to operate and can wake up the CPU when an interrupt/event occurs.

- **Stop mode**

The Stop mode achieves the lowest power consumption while retaining the contents of SRAM and registers. All clocks in the 1.2 V domain are stopped, the PLL, the HSI RC and the HSE crystal oscillators are disabled.

The voltage regulator can be put either in main regulator mode (MR) or in low-power mode (LPR). Both modes can be configured as follows (see [Table 5](#)):

- Normal mode (default mode when MR or LPR is enabled)
- Under-drive mode.

The device can be woken up from the Stop mode by any of the EXTI line (the EXTI line source can be one of the 16 external lines, the PVD output, the RTC alarm / wakeup / tamper / time stamp events, the USB OTG FS/HS wakeup or the Ethernet wakeup).

Table 5. Voltage regulator modes in stop mode

Voltage regulator configuration	Main regulator (MR)	Low-power regulator (LPR)
Normal mode	MR ON	LPR ON
Under-drive mode	MR in under-drive mode	LPR in under-drive mode

- **Standby mode**

The Standby mode is used to achieve the lowest power consumption. The internal voltage regulator is switched off so that the entire 1.2 V domain is powered off. The PLL, the HSI RC and the HSE crystal oscillators are also switched off. After entering Standby mode, the SRAM and register contents are lost except for registers in the backup domain and the backup SRAM when selected.

The device exits the Standby mode when an external reset (NRST pin), an IWDG reset, a rising edge on the WKUP pin, or an RTC alarm / wakeup / tamper /time stamp event occurs.

The standby mode is not supported when the embedded voltage regulator is bypassed and the 1.2 V domain is controlled by an external power.

2.23 V_{BAT} operation

The V_{BAT} pin allows to power the device V_{BAT} domain from an external battery, an external supercapacitor, or from V_{DD} when no external battery and an external supercapacitor are present.

V_{BAT} operation is activated when V_{DD} is not present.

The V_{BAT} pin supplies the RTC, the backup registers and the backup SRAM.

Note: When the microcontroller is supplied from V_{BAT} , external interrupts and RTC alarm/events do not exit it from V_{BAT} operation.

When PDR_ON pin is connected to V_{SS} (Internal Reset OFF), the V_{BAT} functionality is no more available and V_{BAT} pin should be connected to V_{DD} .

2.24 Timers and watchdogs

The devices include two advanced-control timers, eight general-purpose timers, two basic timers and two watchdog timers.

All timer counters can be frozen in debug mode.

Table 6 compares the features of the advanced-control, general-purpose and basic timers.

Table 6. Timer feature comparison

Timer type	Timer	Counter resolution	Counter type	Prescaler factor	DMA request generation	Capture/compare channels	Complementary output	Max interface clock (MHz)	Max timer clock (MHz) ⁽¹⁾
Advanced control	TIM1, TIM8	16-bit	Up, Down, Up/down	Any integer between 1 and 65536	Yes	4	Yes	90	180
General purpose	TIM2, TIM5	32-bit	Up, Down, Up/down	Any integer between 1 and 65536	Yes	4	No	45	90/180
	TIM3, TIM4	16-bit	Up, Down, Up/down	Any integer between 1 and 65536	Yes	4	No	45	90/180
	TIM9	16-bit	Up	Any integer between 1 and 65536	No	2	No	90	180
	TIM10, TIM11	16-bit	Up	Any integer between 1 and 65536	No	1	No	90	180
	TIM12	16-bit	Up	Any integer between 1 and 65536	No	2	No	45	90/180
	TIM13, TIM14	16-bit	Up	Any integer between 1 and 65536	No	1	No	45	90/180
Basic	TIM6, TIM7	16-bit	Up	Any integer between 1 and 65536	Yes	0	No	45	90/180

1. The maximum timer clock is either 90 or 180 MHz depending on TIMPRE bit configuration in the RCC_DCKCFGR register.

2.24.1 Advanced-control timers (TIM1, TIM8)

The advanced-control timers (TIM1, TIM8) can be seen as three-phase PWM generators multiplexed on 6 channels. They have complementary PWM outputs with programmable

inserted dead times. They can also be considered as complete general-purpose timers. Their 4 independent channels can be used for:

- Input capture
- Output compare
- PWM generation (edge- or center-aligned modes)
- One-pulse mode output

If configured as standard 16-bit timers, they have the same features as the general-purpose TIMx timers. If configured as 16-bit PWM generators, they have full modulation capability (0-100%).

The advanced-control timer can work together with the TIMx timers via the Timer Link feature for synchronization or event chaining.

TIM1 and TIM8 support independent DMA request generation.

2.24.2 General-purpose timers (TIMx)

There are ten synchronizable general-purpose timers embedded in the STM32F46x devices (see [Table 6](#) for differences).

- **TIM2, TIM3, TIM4, TIM5**

The STM32F46x include 4 full-featured general-purpose timers: TIM2, TIM5, TIM3, and TIM4. The TIM2 and TIM5 timers are based on a 32-bit auto-reload up/down counter and a 16-bit prescaler. The TIM3 and TIM4 timers are based on a 16-bit auto-reload up/down counter and a 16-bit prescaler. They all feature 4 independent channels for input capture/output compare, PWM or one-pulse mode output. This gives up to 16 input capture/output compare/PWMs on the largest packages.

The TIM2, TIM3, TIM4, TIM5 general-purpose timers can work together, or with the other general-purpose timers and the advanced-control timers TIM1 and TIM8 via the Timer Link feature for synchronization or event chaining.

Any of these general-purpose timers can be used to generate PWM outputs.

TIM2, TIM3, TIM4, TIM5 all have independent DMA request generation. They are capable of handling quadrature (incremental) encoder signals and the digital outputs from 1 to 4 hall-effect sensors.

- **TIM9, TIM10, TIM11, TIM12, TIM13, and TIM14**

These timers are based on a 16-bit auto-reload upcounter and a 16-bit prescaler. TIM10, TIM11, TIM13, and TIM14 feature one independent channel, whereas TIM9 and TIM12 have two independent channels for input capture/output compare, PWM or one-pulse mode output. They can be synchronized with the TIM2, TIM3, TIM4, TIM5 full-featured general-purpose timers. They can also be used as simple time bases.

2.24.3 Basic timers TIM6 and TIM7

These timers are mainly used for DAC trigger and waveform generation. They can also be used as a generic 16-bit time base.

TIM6 and TIM7 support independent DMA request generation.

2.24.4 Independent watchdog

The independent watchdog is based on a 12-bit downcounter and 8-bit prescaler. It is clocked from an independent 32 kHz internal RC and as it operates independently from the

main clock, it can operate in Stop and Standby modes. It can be used either as a watchdog to reset the device when a problem occurs, or as a free-running timer for application timeout management. It is hardware- or software-configurable through the option bytes.

2.24.5 Window watchdog

The window watchdog is based on a 7-bit downcounter that can be set as free-running. It can be used as a watchdog to reset the device when a problem occurs. It is clocked from the main clock. It has an early warning interrupt capability and the counter can be frozen in debug mode.

2.24.6 SysTick timer

This timer is dedicated to real-time operating systems, but could also be used as a standard downcounter. It features:

- A 24-bit downcounter
- Autoreload capability
- Maskable system interrupt generation when the counter reaches 0
- Programmable clock source.

2.25 Inter-integrated circuit interface (I²C)

Up to three I²C bus interfaces can operate in multimaster and slave modes. They can support the standard (up to 100 KHz), and fast (up to 400 KHz) modes. They support the 7/10-bit addressing mode and the 7-bit dual addressing mode (as slave). A hardware CRC generation/verification is embedded.

They can be served by DMA and they support SMBus 2.0/PMBus.

The devices also include programmable analog and digital noise filters (see [Table 7](#)).

Table 7. Comparison of I2C analog and digital filters

	Analog filter	Digital filter
Pulse width of suppressed spikes	≥ 50 ns	Programmable length from 1 to 15 I2C peripheral clocks

2.26 Universal synchronous/asynchronous receiver transmitters (USART)

The devices embed four universal synchronous/asynchronous receiver transmitters (USART1, USART2, USART3 and USART6) and four universal asynchronous receiver transmitters (UART4, UART5, UART7, and UART8).

These six interfaces provide asynchronous communication, IrDA SIR ENDEC support, multiprocessor communication mode, single-wire half-duplex communication mode and have LIN Master/Slave capability. The USART1 and USART6 interfaces are able to communicate at speeds of up to 11.25 Mbit/s. The other available interfaces communicate at up to 5.62 bit/s.

USART1, USART2, USART3 and USART6 also provide hardware management of the CTS and RTS signals, Smart Card mode (ISO 7816 compliant) and SPI-like communication capability. All interfaces can be served by the DMA controller.

Table 8. USART feature comparison⁽¹⁾

USART name	Standard features	Modem (RTS/CTS)	LIN	SPI master	irDA	Smartcard (ISO 7816)	Max. baud rate in Mbit/s (oversampling by 16)	Max. baud rate in Mbit/s (oversampling by 8)	APB mapping
USART1	X	X	X	X	X	X	5.62	11.25	APB2 (max. 90 MHz)
USART2	X	X	X	X	X	X	2.81	5.62	APB1 (max. 45 MHz)
USART3	X	X	X	X	X	X	2.81	5.62	APB1 (max. 45 MHz)
UART4	X	-	X	-	X	-	2.81	5.62	APB1 (max. 45 MHz)
UART5	X	-	X	-	X	-	2.81	5.62	APB1 (max. 45 MHz)
USART6	X	X	X	X	X	X	5.62	11.25	APB2 (max. 90 MHz)
UART7	X	-	X	-	X	-	2.81	5.62	APB1 (max. 45 MHz)
UART8	X	-	X	-	X	-	2.81	5.62	APB1 (max. 45 MHz)

1. X = feature supported.

2.27 Serial peripheral interface (SPI)

The devices feature up to six SPIs in slave and master modes in full-duplex and simplex communication modes. SPI1, SPI4, SPI5, and SPI6 can communicate at up to 45 Mbits/s, SPI2 and SPI3 can communicate at up to 22.5 Mbit/s. The 3-bit prescaler gives 8 master mode frequencies and the frame is configurable to 8 bits or 16 bits. The hardware CRC generation/verification supports basic SD Card/MMC modes. All SPIs can be served by the DMA controller.

The SPI interface can be configured to operate in TI mode for communications in master mode and slave mode.

2.28 Inter-integrated sound (I²S)

Two standard I²S interfaces (multiplexed with SPI2 and SPI3) are available. They can be operated in master or slave mode, in full duplex and simplex communication modes, and can be configured to operate with a 16-/32-bit resolution as an input or output channel. Audio sampling frequencies from 8 kHz up to 192 kHz are supported. When either or both of the I²S interfaces is/are configured in master mode, the master clock can be output to the external DAC/CODEC at 256 times the sampling frequency.

All I2Sx can be served by the DMA controller.

Note: For I2S2 full-duplex mode, I2S2_CK and I2S2_WS signals can be used only on GPIO Port B and GPIO Port D.

2.29 Serial Audio interface (SAI1)

The serial audio interface (SAI1) is based on two independent audio sub-blocks which can operate as transmitter or receiver with their FIFO. Many audio protocols are supported by each block: I2S standards, LSB or MSB-justified, PCM/DSP, TDM, AC'97 and SPDIF output, supporting audio sampling frequencies from 8 kHz up to 192 kHz. Both sub-blocks can be configured in master or in slave mode.

In master mode, the master clock can be output to the external DAC/CODEC at 256 times of the sampling frequency.

The two sub-blocks can be configured in synchronous mode when full-duplex mode is required.

SAI1 can be served by the DMA controller.

2.30 Audio PLL (PLLI2S)

The devices feature an additional dedicated PLL for audio I²S and SAI applications. It allows to achieve error-free I²S sampling clock accuracy without compromising on the CPU performance, while using USB peripherals.

The PLLI2S configuration can be modified to manage an I²S/SAI sample rate change without disabling the main PLL (PLL) used for CPU, USB and Ethernet interfaces.

The audio PLL can be programmed with very low error to obtain sampling rates ranging from 8 KHz to 192 KHz.

In addition to the audio PLL, a master clock input pin can be used to synchronize the I²S/SAI flow with an external PLL (or Codec output).

2.31 Audio and LCD PLL(PLLSAI)

An additional PLL dedicated to audio and LCD-TFT is used for SAI1 peripheral in case the PLLI2S is programmed to achieve another audio sampling frequency (49.152 MHz or 11.2896 MHz) and the audio application requires both sampling frequencies simultaneously.

The PLLSAI is also used to generate the LCD-TFT clock.

2.32 Secure digital input/output interface (SDIO)

An SD/SDIO/MMC host interface is available, that supports MultiMediaCard System Specification Version 4.2 in three different databus modes: 1-bit (default), 4-bit and 8-bit.

The interface allows data transfer at up to 48 MHz, and is compliant with the SD Memory Card Specification Version 2.0.

The SDIO Card Specification Version 2.0 is also supported with two different databus modes: 1-bit (default) and 4-bit.

The current version supports only one SD/SDIO/MMC4.2 card at any one time and a stack of MMC4.1 or previous.

In addition to SD/SDIO/MMC, this interface is fully compliant with the CE-ATA digital protocol Rev1.1.

2.33 Ethernet MAC interface with dedicated DMA and IEEE 1588 support

The devices provide an IEEE-802.3-2002-compliant media access controller (MAC) for ethernet LAN communications through an industry-standard medium-independent interface (MII) or a reduced medium-independent interface (RMII). The microcontroller requires an external physical interface device (PHY) to connect to the physical LAN bus (twisted-pair, fiber, etc.). The PHY is connected to the device MII port using 17 signals for MII or 9 signals for RMII, and can be clocked using the 25 MHz (MII) from the microcontroller.

The devices include the following features:

- Supports 10 and 100 Mbit/s rates
- Dedicated DMA controller allowing high-speed transfers between the dedicated SRAM and the descriptors (see the STM32F4xx reference manual for details)
- Tagged MAC frame support (VLAN support)
- Half-duplex (CSMA/CD) and full-duplex operation
- MAC control sublayer (control frames) support
- 32-bit CRC generation and removal
- Several address filtering modes for physical and multicast address (multicast and group addresses)
- 32-bit status code for each transmitted or received frame
- Internal FIFOs to buffer transmit and receive frames. The transmit FIFO and the receive FIFO are both 2 Kbytes.
- Supports hardware PTP (precision time protocol) in accordance with IEEE 1588 2008 (PTP V2) with the time stamp comparator connected to the TIM2 input
- Triggers interrupt when system time becomes greater than target time

2.34 Controller area network (bxCAN)

The two CANs are compliant with the 2.0A and B (active) specifications with a bitrate up to 1 Mbit/s. They can receive and transmit standard frames with 11-bit identifiers as well as extended frames with 29-bit identifiers. Each CAN has three transmit mailboxes, two receive

FIFOS with 3 stages and 28 shared scalable filter banks (all of them can be used even if one CAN is used). 256 bytes of SRAM are allocated for each CAN.

2.35 Universal serial bus on-the-go full-speed (OTG_FS)

The device embeds an USB OTG full-speed device/host/OTG peripheral with integrated transceivers. The USB OTG FS peripheral is compliant with the USB 2.0 specification and with the OTG 2.0 specification. It has software-configurable endpoint setting and supports suspend/resume. The USB OTG controller requires a dedicated 48 MHz clock that is generated by a PLL connected to the HSE oscillator.

The major features are:

- Combined Rx and Tx FIFO size of 1.28 KB with dynamic FIFO sizing
- Supports the session request protocol (SRP) and host negotiation protocol (HNP)
- 1 bidirectional control endpoint + 5 IN endpoints + 5 OUT endpoints
- 12 host channels with periodic OUT support
- Software configurable to OTG1.3 and OTG2.0 modes of operation
- USB 2.0 LPM (Link Power Management) support
- Internal FS OTG PHY support
- HNP/SNP/IP inside (no need for any external resistor)

For OTG/Host modes, a power switch is needed in case bus-powered devices are connected

2.36 Universal serial bus on-the-go high-speed (OTG_HS)

The device embeds a USB OTG high-speed (up to 480 Mb/s) device/host/OTG peripheral. The USB OTG HS supports both full-speed and high-speed operations. It integrates the transceivers for full-speed operation (12 MB/s) and features a UTMI low-pin interface (ULPI) for high-speed operation (480 MB/s). When using the USB OTG HS in HS mode, an external PHY device connected to the ULPI is required.

The USB OTG HS peripheral is compliant with the USB 2.0 specification and with the OTG 2.0 specification. It has software-configurable endpoint setting and supports suspend/resume. The USB OTG controller requires a dedicated 48 MHz clock that is generated by a PLL connected to the HSE oscillator.

The major features are:

- Combined Rx and Tx FIFO size of 4 KB with dynamic FIFO sizing
- Supports the session request protocol (SRP) and host negotiation protocol (HNP)
- 8 bidirectional endpoints
- 16 host channels with periodic OUT support
- Software configurable to OTG1.3 and OTG2.0 modes of operation
- USB 2.0 LPM (Link Power Management) support
- Internal FS OTG PHY support
- External HS or HS OTG operation supporting ULPI in SDR mode. The OTG PHY is connected to the microcontroller ULPI port through 12 signals. It can be clocked using the 60 MHz output.
- Internal USB DMA
- HNP/SNP/IP inside (no need for any external resistor)
- for OTG/Host modes, a power switch is needed in case bus-powered devices are connected

2.37 Digital camera interface (DCMI)

The devices embed a camera interface that can connect with camera modules and CMOS sensors through an 8-bit to 14-bit parallel interface, to receive video data. The camera interface can sustain a data transfer rate up to 54 Mbyte/s at 54 MHz. It features:

- Programmable polarity for the input pixel clock and synchronization signals
- Parallel data communication can be 8-, 10-, 12- or 14-bit
- Supports 8-bit progressive video monochrome or raw bayer format, YCbCr 4:2:2 progressive video, RGB 565 progressive video or compressed data (like JPEG)
- Supports continuous mode or snapshot (a single frame) mode
- Capability to automatically crop the image black & white.

2.38 Random number generator (RNG)

All devices embed an RNG that delivers 32-bit random numbers generated by an integrated analog circuit.

2.39 General-purpose input/outputs (GPIOs)

Each of the GPIO pins can be configured by software as output (push-pull or open-drain, with or without pull-up or pull-down), as input (floating, with or without pull-up or pull-down) or as peripheral alternate function. Most of the GPIO pins are shared with digital or analog alternate functions. All GPIOs are high-current-capable and have speed selection to better manage internal noise, power consumption and electromagnetic emission.

The I/O configuration can be locked if needed by following a specific sequence in order to avoid spurious writing to the I/Os registers.

Fast I/O handling allowing maximum I/O toggling up to 90 MHz.

2.40 Analog-to-digital converters (ADCs)

Three 12-bit analog-to-digital converters are embedded and each ADC shares up to 16 external channels, performing conversions in the single-shot or scan mode. In scan mode, automatic conversion is performed on a selected group of analog inputs.

Additional logic functions embedded in the ADC interface allow:

- Simultaneous sample and hold
- Interleaved sample and hold

The ADC can be served by the DMA controller. An analog watchdog feature allows very precise monitoring of the converted voltage of one, some or all selected channels. An interrupt is generated when the converted voltage is outside the programmed thresholds.

To synchronize A/D conversion and timers, the ADCs could be triggered by any of TIM1, TIM2, TIM3, TIM4, TIM5, or TIM8 timer.

2.41 Temperature sensor

The temperature sensor has to generate a voltage that varies linearly with temperature. The conversion range is between 1.7 V and 3.6 V. The temperature sensor is internally connected to the same input channel as V_{BAT} , ADC1_IN18, which is used to convert the sensor output voltage into a digital value. When the temperature sensor and V_{BAT} conversion are enabled at the same time, only V_{BAT} conversion is performed.

As the offset of the temperature sensor varies from chip to chip due to process variation, the internal temperature sensor is mainly suitable for applications that detect temperature changes instead of absolute temperatures. If an accurate temperature reading is needed, then an external temperature sensor part should be used.

2.42 Digital-to-analog converter (DAC)

The two 12-bit buffered DAC channels can be used to convert two digital signals into two analog voltage signal outputs.

This dual digital Interface supports the following features:

- two DAC converters: one for each output channel
- 8-bit or 10-bit monotonic output
- left or right data alignment in 12-bit mode
- synchronized update capability
- noise-wave generation
- triangular-wave generation
- dual DAC channel independent or simultaneous conversions
- DMA capability for each channel
- external triggers for conversion
- input voltage reference V_{REF+}

Eight DAC trigger inputs are used in the device. The DAC channels are triggered through the timer update outputs that are also connected to different DMA streams.

2.43 Serial wire JTAG debug port (SWJ-DP)

The ARM SWJ-DP interface is embedded, and is a combined JTAG and serial wire debug port that enables either a serial wire debug or a JTAG probe to be connected to the target.

Debug is performed using 2 pins only instead of 5 required by the JTAG (JTAG pins could be re-use as GPIO with alternate function): the JTAG TMS and TCK pins are shared with SWDIO and SWCLK, respectively, and a specific sequence on the TMS pin is used to switch between JTAG-DP and SW-DP.

2.44 Embedded Trace Macrocell™

The ARM Embedded Trace Macrocell provides a greater visibility of the instruction and data flow inside the CPU core by streaming compressed data at a very high rate from the STM32F46x through a small number of ETM pins to an external hardware trace port analyzer (TPA) device. The TPA is connected to a host computer using USB, Ethernet, or any other high-speed channel. Real-time instruction and data flow activity can be recorded and then formatted for display on the host computer that runs the debugger software. TPA hardware is commercially available from common development tool vendors.

The Embedded Trace Macrocell operates with third party debugger software tools.

3 Pinouts and pin description

Figure 13. STM32F46x WLCSP168 pinout

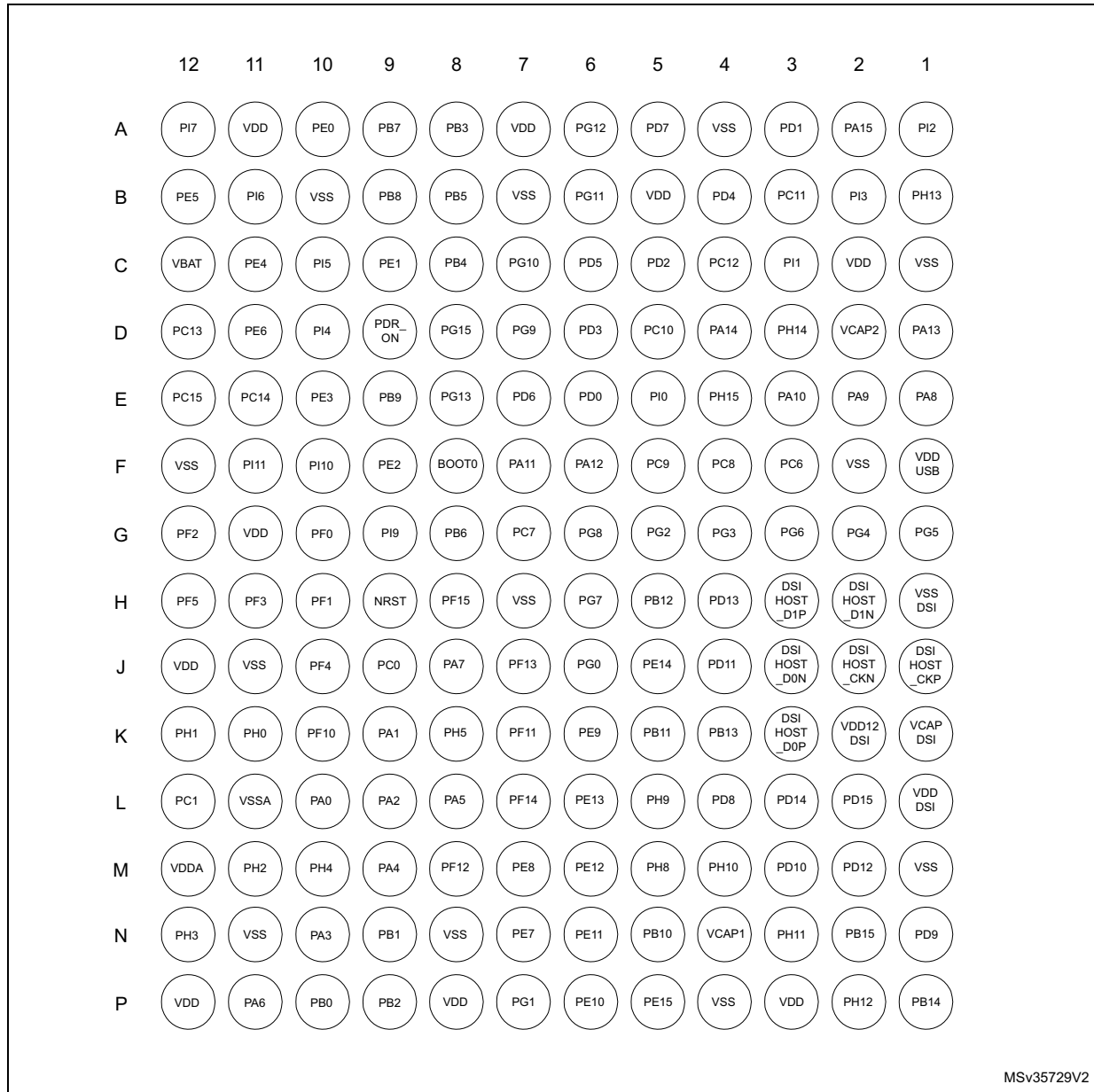

MSv35729V2

1. The above figure shows the package bottom view.

Figure 14. STM32F46x UFBGA169 ballout

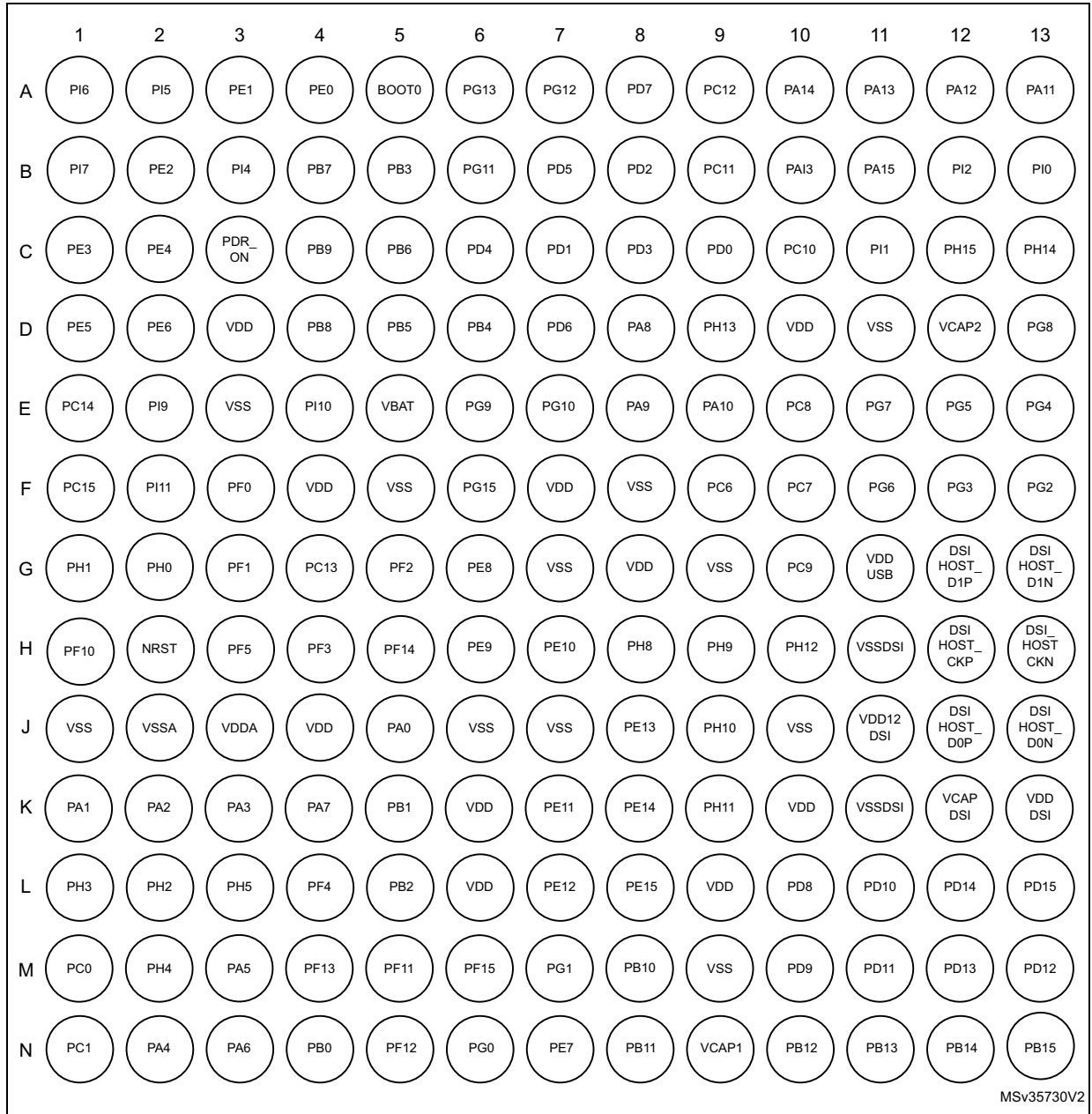

MSv35730V2

1. The above figure shows the package top view.

Figure 15. STM32F46x UFBGA176 ballout

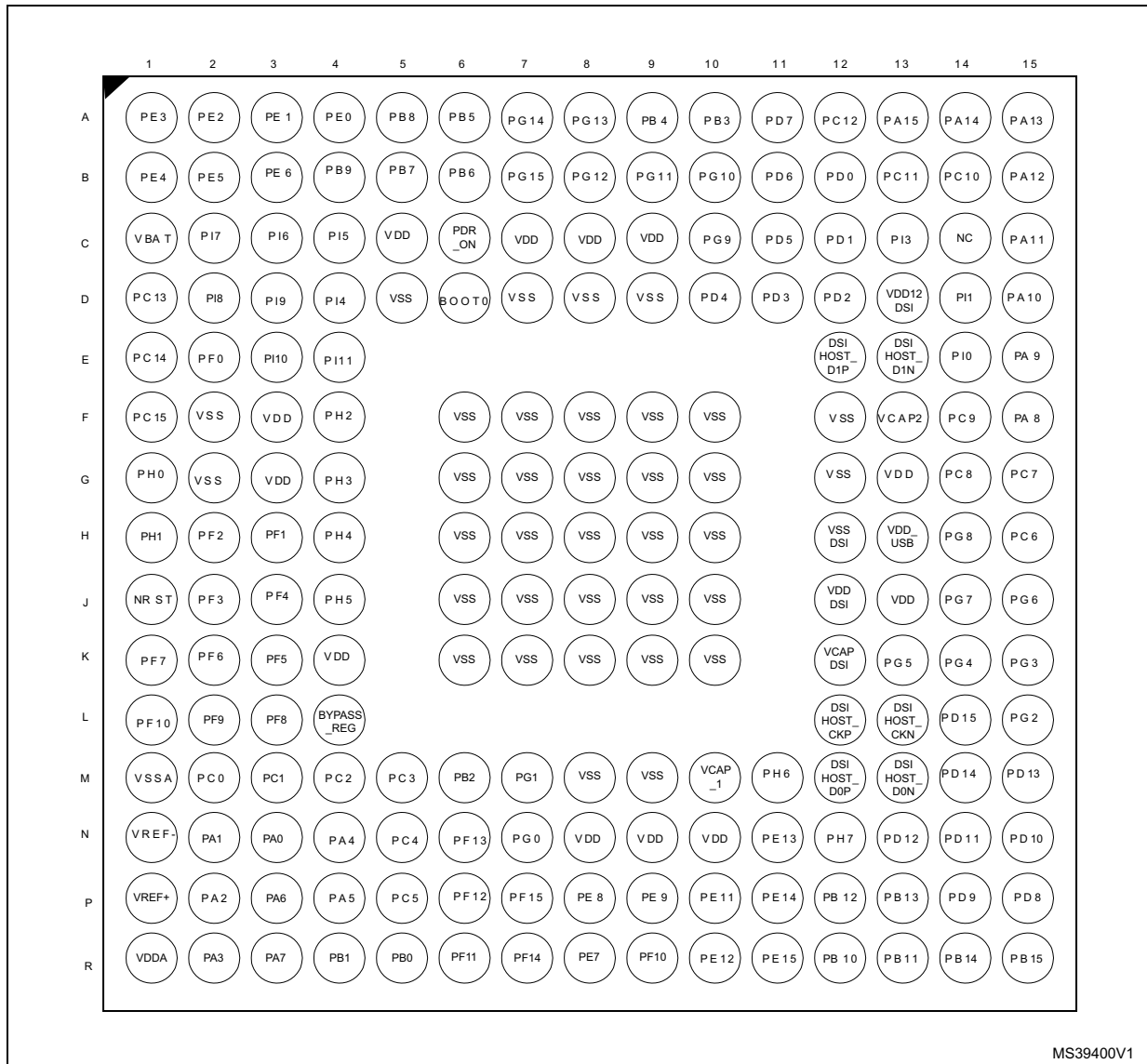

MS39400V1

1. The above figure shows the package top view.

Figure 16. STM32F46x LQFP176 pinout

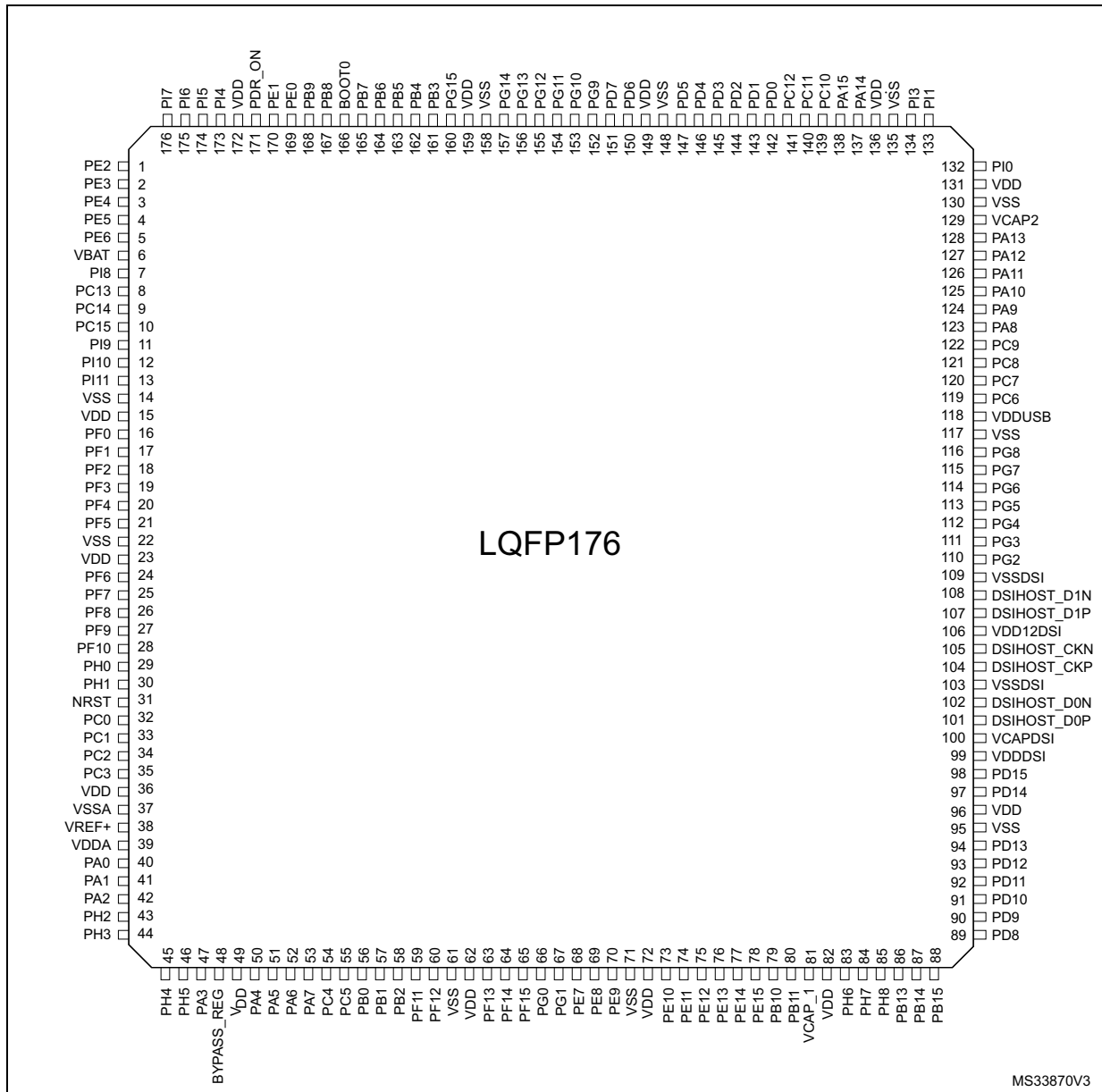

1. The above figure shows the package top view.

Figure 17. STM32F46x LQFP208 pinout

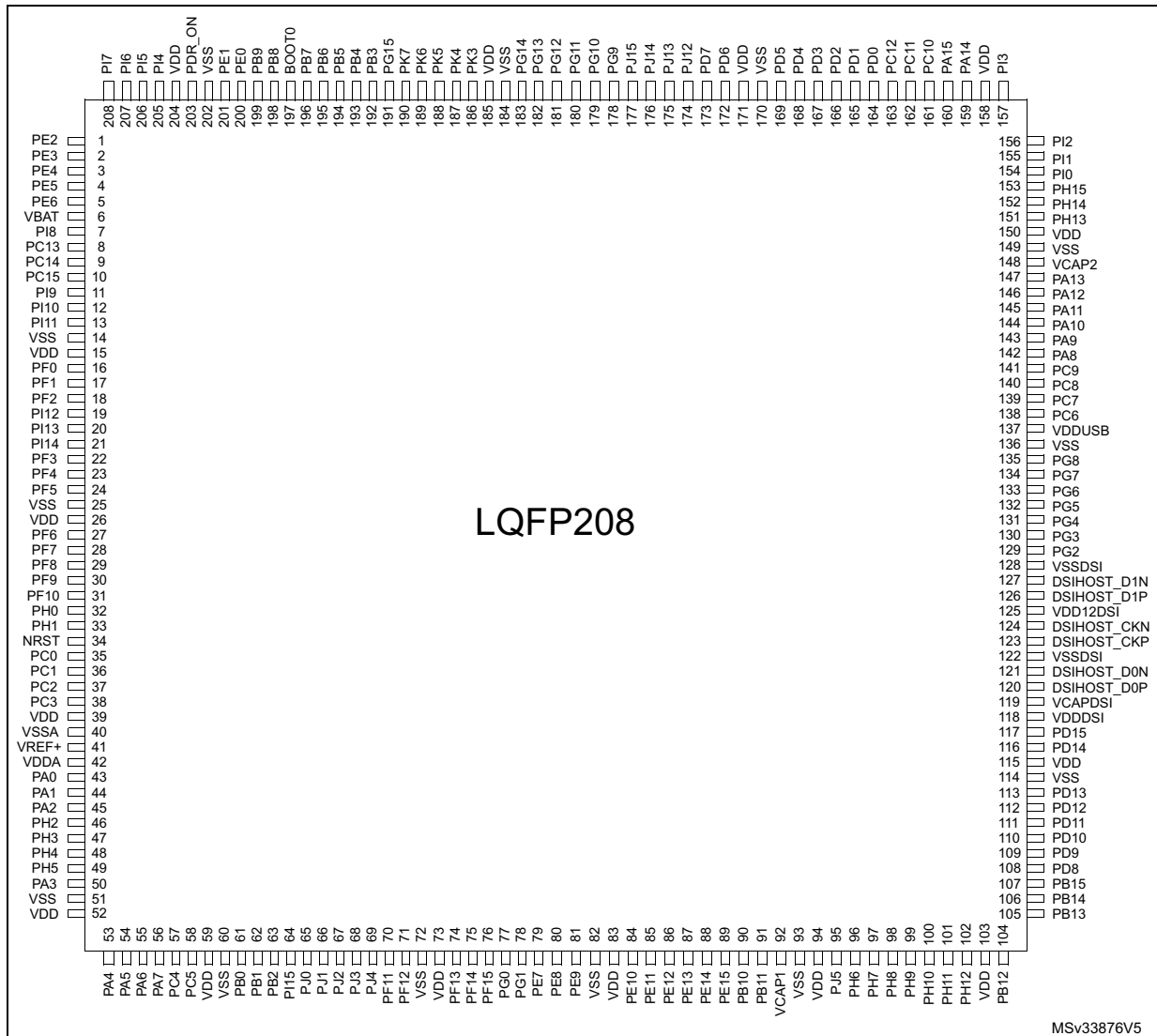

1. The above figure shows the package top view.

Figure 18. STM32F46x TFBGA216 ballout

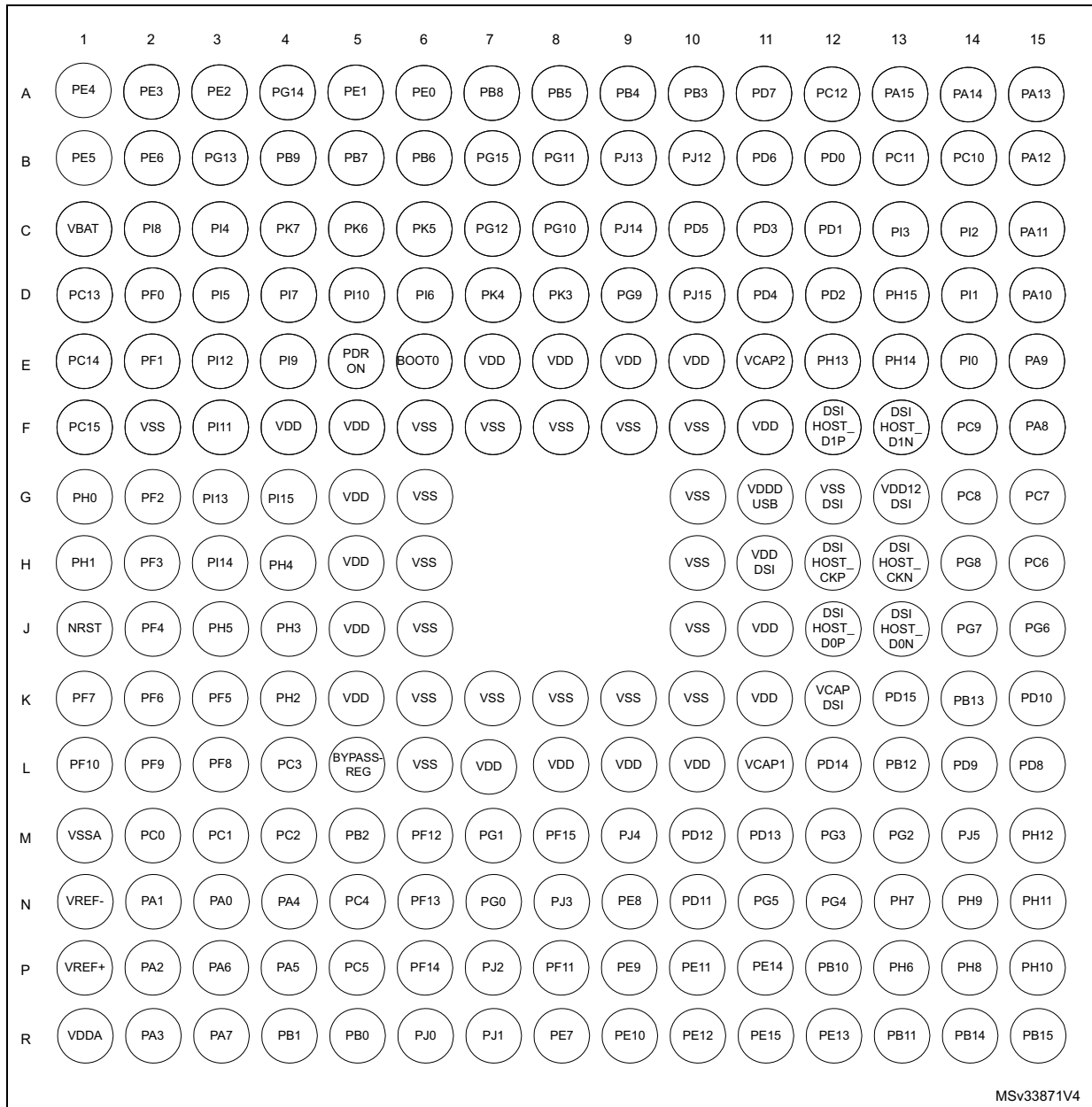

MSV33871V4

1. The above figure shows the package top view.

Table 9. Legend/abbreviations used in the pinout table

Name	Abbreviation	Definition
Pin name	Unless otherwise specified in brackets below the pin name, the pin function during and after reset is the same as the actual pin name	
Pin type	S	Supply pin
	I	Input only pin
	I/O	Input / output pin
I/O structure	FT	5 V tolerant I/O
	TTa	3.3 V tolerant I/O directly connected to analog parts
	B	Dedicated BOOT0 pin
	RST	Bidirectional reset pin with weak pull-up resistor
Notes	Unless otherwise specified by a note, all I/Os are set as floating inputs during and after reset	
Alternate functions	Functions selected through GPIOx_AFR registers	
Additional functions	Functions directly selected/enabled through peripheral registers	

Table 10. STM32F469xx pin and ball definitions

Pin Number						Pin name (function after reset) ⁽¹⁾	Pin types	I/O structures	Notes	Alternate functions	Additional functions
UFBGA169	WLCSP168	UFBGA176	LQFP176	LQFP208	TFBGA216						
B2	F9	A2	1	1	A3	PE2	I/O	FT	-	TRACECLK, SPI4_SCK, SAI1_MCLK_A, QUADSPI_BK1_IO2, ETH_MII_TXD3, FMC_A23, EVENTOUT	-
C1	E10	A1	2	2	A2	PE3	I/O	FT	-	TRACED0, SAI1_SD_B, FMC_A19, EVENTOUT	-
C2	C11	B1	3	3	A1	PE4	I/O	FT	-	TRACED1, SPI4_NSS, SAI1_FS_A, FMC_A20, DCMI_D4, LCD_B0, EVENTOUT	-
D1	B12	B2	4	4	B1	PE5	I/O	FT	-	TRACED2, TIM9_CH1, SPI4_MISO, SAI1_SCK_A, FMC_A21, DCMI_D6, LCD_G0, EVENTOUT	-
D2	D11	B3	5	5	B2	PE6	I/O	FT	-	TRACED3, TIM9_CH2, SPI4_MOSI, SAI1_SD_A, FMC_A22, DCMI_D7, LCD_G1, EVENTOUT	-
-	-	-	-	-	G6	VSS	S	-	-	-	-
-	-	-	-	-	F5	VDD	S	-	-	-	-
E5	C12	C1	6	6	C1	VBAT	S	-	-	-	-
-	-	D2	7	7	C2	PI8	I/O	FT	(2) (3)	EVENTOUT	RTC_TAMP1/ RTC_TAMP2/ RTC_TS
G4	D12	D1	8	8	D1	PC13	I/O	FT	(2) (3)	EVENTOUT	RTC_TAMP1/ RTC_TS/ RTC_OUT
E1	E11	E1	9	9	E1	PC14- OSC32_IN (PC14)	I/O	FT	(2) (3)	EVENTOUT	OSC32_IN
F1	E12	F1	10	10	F1	PC15- OSC32_OUT (PC15)	I/O	FT	(2) (3)	EVENTOUT	OSC32_OUT
-	-	-	-	-	G5	VDD	S	-	-	-	-
E2	G9	D3	11	11	E4	PI9	I/O	FT		CAN1_RX, FMC_D30, LCD_VSYNC, EVENTOUT	-

Table 10. STM32F469xx pin and ball definitions (continued)

Pin Number						Pin name (function after reset) ⁽¹⁾	Pin types	I/O structures	Notes	Alternate functions	Additional functions
UFBGA169	WLCSP168	UFBGA176	LQFP176	LQFP208	TFBGA216						
E4	F10	E3	12	12	D5	PI10	I/O	FT		ETH_MII_RX_ER, FMC_D31, LCD_HSYNC, EVENTOUT	-
F2	F11	E4	13	13	F3	PI11	I/O	FT		LCD_G6, OTG_HS_ULPI_DIR, EVENTOUT	-
F5	F12	F2	14	14	F2	VSS	S	-	-	-	-
F4	G11	F3	15	15	F4	VDD	S	-	-	-	-
F3	G10	E2	16	16	D2	PF0	I/O	FT		I2C2_SDA, FMC_A0, EVENTOUT	-
G3	H10	H3	17	17	E2	PF1	I/O	FT		I2C2_SCL, FMC_A1, EVENTOUT	-
G5	G12	H2	18	18	G2	PF2	I/O	FT		I2C2_SMBA, FMC_A2, EVENTOUT	-
-	-	-	-	19	E3	PI12	I/O	FT		LCD_HSYNC, EVENTOUT	-
-	-	-	-	20	G3	PI13	I/O	FT		LCD_VSYNC, EVENTOUT	-
-	-	-	-	21	H3	PI14	I/O	FT		LCD_CLK, EVENTOUT	-
H4	H11	J2	19	22	H2	PF3	I/O	FT	⁽⁴⁾	FMC_A3, EVENTOUT	ADC3_IN9
L4	J10	J3	20	23	J2	PF4	I/O	FT	⁽⁴⁾	FMC_A4, EVENTOUT	ADC3_IN14
H3	H12	K3	21	24	K3	PF5	I/O	FT	⁽⁴⁾	FMC_A5, EVENTOUT	ADC3_IN15
G7	J11	G2	22	25	H6	VSS	S	-	-	-	-
G8	J12	G3	23	26	H5	VDD	S	-	-	-	-
-	-	K2	24	27	K2	PF6	I/O	FT	⁽⁴⁾	TIM10_CH1, SPI5_NSS, SAI1_SD_B, UART7_Rx, QUADSPI_BK1_IO3, EVENTOUT	ADC3_IN4
-	-	K1	25	28	K1	PF7	I/O	FT	⁽⁴⁾	TIM11_CH1, SPI5_SCK, SAI1_MCLK_B, UART7_Tx, QUADSPI_BK1_IO2, EVENTOUT	ADC3_IN5
-	-	L3	26	29	L3	PF8	I/O	FT	⁽⁴⁾	SPI5_MISO, SAI1_SCK_B, TIM13_CH1, QUADSPI_BK1_IO0, EVENTOUT	ADC3_IN6

Table 10. STM32F469xx pin and ball definitions (continued)

Pin Number						Pin name (function after reset) ⁽¹⁾	Pin types	I/O structures	Notes	Alternate functions	Additional functions
UFBGA169	WLCSP168	UFBGA176	LQFP176	LQFP208	TFBGA216						
-	-	L2	27	30	L2	PF9	I/O	FT	(4)	SPI5_MOSI, SAI1_FS_B, TIM14_CH1, QUADSPI_BK1_IO1, EVENTOUT	ADC3_IN7
H1	K10	L1	28	31	L1	PF10	I/O	FT	(4)	QUADSPI_CLK, DCMI_D11, LCD_DE, EVENTOUT	ADC3_IN8
G2	K11	G1	29	32	G1	PH0-OSC_IN (PH0)	I/O	FT	-	EVENTOUT	OSC_IN
G1	K12	H1	30	33	H1	PH1-OSC_OUT (PH1)	I/O	FT	-	EVENTOUT	OSC_OUT
H2	H9	J1	31	34	J1	NRST	I/O	RST	-		
M1	J9	M2	32	35	M2	PC0	I/O	FT	(4)	OTG_HS_ULPI_STP, FMC_SDNWE, LCD_R5, EVENTOUT	ADC123_IN10
N1	L12	M3	33	36	M3	PC1	I/O	FT	(4)	TRACED0, SPI2_MOSI/I2S2_SD, SAI1_SD_A, ETH_MDC, EVENTOUT	ADC123_IN11
-	-	M4	34	37	M4	PC2	I/O	FT	(4)	SPI2_MISO, I2S2ext_SD, OTG_HS_ULPI_DIR, ETH_MII_TXD2, FMC_SDNE0, EVENTOUT	ADC123_IN12
-	-	M5	35	38	L4	PC3	I/O	FT	(4)	SPI2_MOSI/I2S2_SD, OTG_HS_ULPI_NXT, ETH_MII_TX_CLK, FMC_SDCKE0, EVENTOUT	ADC123_IN13
-	-	-	36	39	J5	VDD	S	-	-	-	-
-	-	-	-	-	J6	VSS	S	-	-	-	-
J2	L11	M1	37	40	M1	VSSA	S	-	-	-	-
-	-	N1	-	-	N1	VREF-	S	-	-	-	-
-	-	P1	38	41	P1	VREF+	S	-	-	-	-
J3	M12	R1	39	42	R1	VDDA	S	-	-	-	-
J5	L10	N3	40	43	N3	PA0- WKUP(PA0)	I/O	FT	(5)	TIM2_CH1/TIM2_ETR, TIM5_CH1, TIM8_ETR, USART2_CTS, UART4_TX, ETH_MII_CRCS, EVENTOUT	ADC123_IN0, WKUP

Table 10. STM32F469xx pin and ball definitions (continued)

Pin Number						Pin name (function after reset) ⁽¹⁾	Pin types	I/O structures	Notes	Alternate functions	Additional functions
UFBGA169	WLCSP168	UFBGA176	LQFP176	LQFP208	TFBGA216						
K1	K9	N2	41	44	N2	PA1	I/O	FT	(4)	TIM2_CH2, TIM5_CH2, USART2_RTS, UART4_RX, QUADSPI_BK1_IO3, ETH_MII_RX_CLK/ETH_ RMII_REF_CLK, LCD_R2, EVENTOUT	ADC123_IN1
K2	L9	P2	42	45	P2	PA2	I/O	FT	(4)	TIM2_CH3, TIM5_CH3, TIM9_CH1, USART2_TX, ETH_MDIO, LCD_R1, EVENTOUT	ADC123_IN2
L2	M11	F4	43	46	K4	PH2	I/O	FT	-	QUADSPI_BK2_IO0, ETH_MII_CRD, FMC_SDCKE0, LCD_R0, EVENTOUT	-
L1	N12	G4	44	47	J4	PH3	I/O	FT	-	QUADSPI_BK2_IO1, ETH_MII_COL, FMC_SDNE0, LCD_R1, EVENTOUT	-
M2	M10	H4	45	48	H4	PH4	I/O	FT	-	I2C2_SCL, LCD_G5, OTG_HS_ULPI_NXT, LCD_G4, EVENTOUT	-
L3	K8	J4	46	49	J3	PH5	I/O	FT	-	I2C2_SDA, SPI5_NSS, FMC_SDNWE, EVENTOUT	-
K3	N10	R2	47	50	R2	PA3	I/O	FT	(4)	TIM2_CH4, TIM5_CH4, TIM9_CH2, USART2_RX, LCD_B2, OTG_HS_ULPI_D0, ETH_MII_COL, LCD_B5, EVENTOUT	ADC123_IN3
J1	N11	-	-	51	K6	VSS	S	-	-	-	-
-	-	L4	48	-	L5	BYPASS_REG	I	FT	-	-	-
J4	P12	K4	49	52	K5	VDD	S	-	-	-	-
N2	M9	N4	50	53	N4	PA4	I/O	TTa	-	SPI1_NSS, SPI3_NSS/I2S3_WS, USART2_CK, OTG_HS_SOF, DCMI_HSYNC, LCD_VSYNC, EVENTOUT	ADC12_IN4, DAC_OUT1

Table 10. STM32F469xx pin and ball definitions (continued)

Pin Number						Pin name (function after reset) ⁽¹⁾	Pin types	I/O structures	Notes	Alternate functions	Additional functions
UFBGA169	WLCSP168	UFBGA176	LQFP176	LQFP208	TFBGA216						
M3	L8	P4	51	54	P4	PA5	I/O	TTa	-	TIM2_CH1/TIM2_ETR, TIM8_CH1N, SPI1_SCK, OTG_HS_ULPI_CK, LCD_R4, EVENTOUT	ADC12_IN5, DAC_OUT2
N3	P11	P3	52	55	P3	PA6	I/O	FT	(4)	TIM1_BKIN, TIM3_CH1, TIM8_BKIN, SPI1_MISO, TIM13_CH1, DCMI_PIXCLK, LCD_G2, EVENTOUT	ADC12_IN6
K4	J8	R3	53	56	R3	PA7	I/O	FT	(4)	TIM1_CH1N, TIM3_CH2, TIM8_CH1N, SPI1_MOSI, TIM14_CH1, QUADSPI_CLK, ETH_MII_RX_DV/ETH_R MII_CRS_DV, FMC_SDNWE, EVENTOUT	ADC12_IN7
-	-	N5	54	57	N5	PC4	I/O	FT	(4)	ETH_MII_RXD0/ETH_RMI I_RXD0, FMC_SDNE0, EVENTOUT	ADC12_IN14
-	-	P5	55	58	P5	PC5	I/O	FT	(4)	ETH_MII_RXD1/ETH_RMI I_RXD1, FMC_SDCKE0, EVENTOUT	ADC12_IN15
-	-	-	-	59	L7	VDD	S	-	-	-	-
-	-	-	-	60	L6	VSS	S	-	-	-	-
N4	P10	R5	56	61	R5	PB0	I/O	FT	(4)	TIM1_CH2N, TIM3_CH3, TIM8_CH2N, LCD_R3, OTG_HS_ULPI_D1, ETH_MII_RXD2, LCD_G1, EVENTOUT	ADC12_IN8
K5	N9	R4	57	62	R4	PB1	I/O	FT	(4)	TIM1_CH3N, TIM3_CH4, TIM8_CH3N, LCD_R6, OTG_HS_ULPI_D2, ETH_MII_RXD3, LCD_G0, EVENTOUT	ADC12_IN9
L5	P9	M6	58	63	M5	PB2- BOOT1(PB2)	I/O	FT	-	EVENTOUT	-
-	-	-	-	64	G4	PI15	I/O	FT	-	LCD_G2, LCD_R0, EVENTOUT	-
-	-	-	-	65	R6	PJ0	I/O	FT	-	LCD_R7, LCD_R1, EVENTOUT	-
-	-	-	-	66	R7	PJ1	I/O	FT	-	LCD_R2, EVENTOUT	-

Table 10. STM32F469xx pin and ball definitions (continued)

Pin Number						Pin name (function after reset) ⁽¹⁾	Pin types	I/O structures	Notes	Alternate functions	Additional functions
UFBGA169	WLCSP168	UFBGA176	LQFP176	LQFP208	TFBGA216						
-	-	-	-	67	P7	PJ2	I/O	FT	-	DSIHOST_TE, LCD_R3, EVENTOUT	-
-	-	-	-	68	N8	PJ3	I/O	FT	-	LCD_R4, EVENTOUT	-
-	-	-	-	69	M9	PJ4	I/O	FT	-	LCD_R5, EVENTOUT	-
M5	K7	R6	59	70	P8	PF11	I/O	FT	-	SPI5_MOSI, FMC_SDNRAS, DCMI_D12, EVENTOUT	-
N5	M8	P6	60	71	M6	PF12	I/O	FT	-	FMC_A6, EVENTOUT	-
J6	N8	M8	61	72	K7	VSS	S	-	-	-	-
K6	P8	N8	62	73	L8	VDD	S	-	-	-	-
M4	J7	N6	63	74	N6	PF13	I/O	FT	-	FMC_A7, EVENTOUT	-
H5	L7	R7	64	75	P6	PF14	I/O	FT	-	FMC_A8, EVENTOUT	-
M6	H8	P7	65	76	M8	PF15	I/O	FT	-	FMC_A9, EVENTOUT	-
N6	J6	N7	66	77	N7	PG0	I/O	FT	-	FMC_A10, EVENTOUT	-
M7	P7	M7	67	78	M7	PG1	I/O	FT	-	FMC_A11, EVENTOUT	-
N7	N7	R8	68	79	R8	PE7	I/O	FT	-	TIM1_ETR, UART7_Rx, QUADSPI_BK2_IO0, FMC_D4, EVENTOUT	-
G6	M7	P8	69	80	N9	PE8	I/O	FT	-	TIM1_CH1N, UART7_Tx, QUADSPI_BK2_IO1, FMC_D5, EVENTOUT	-
H6	K6	P9	70	81	P9	PE9	I/O	FT	-	TIM1_CH1, QUADSPI_BK2_IO2, FMC_D6, EVENTOUT	-
J7	-	M9	71	82	K8	VSS	S	-	-	-	-
L6	-	N9	72	83	L9	VDD	S	-	-	-	-
H7	P6	R9	73	84	R9	PE10	I/O	FT	-	TIM1_CH2N, QUADSPI_BK2_IO3, FMC_D7, EVENTOUT	-
K7	N6	P10	74	85	P10	PE11	I/O	FT	-	TIM1_CH2, SPI4_NSS, FMC_D8, LCD_G3, EVENTOUT	-
L7	M6	R10	75	86	R10	PE12	I/O	FT	-	TIM1_CH3N, SPI4_SCK, FMC_D9, LCD_B4, EVENTOUT	-
J8	L6	N11	76	87	R12	PE13	I/O	FT	-	TIM1_CH3, SPI4_MISO, FMC_D10, LCD_DE, EVENTOUT	-

Table 10. STM32F469xx pin and ball definitions (continued)

Pin Number						Pin name (function after reset) ⁽¹⁾	Pin types	I/O structures	Notes	Alternate functions	Additional functions
UFBGA169	WLCSP168	UFBGA176	LQFP176	LQFP208	TFBGA216						
K8	J5	P11	77	88	P11	PE14	I/O	FT	-	TIM1_CH4, SPI4_MOSI, FMC_D11, LCD_CLK, EVENTOUT	-
L8	P5	R11	78	89	R11	PE15	I/O	FT	-	TIM1_BKIN, FMC_D12, LCD_R7, EVENTOUT	-
M8	N5	R12	79	90	P12	PB10	I/O	FT	-	TIM2_CH3, I2C2_SCL, SPI2_SCK/I2S2_CK, USART3_TX, QUADSPI_BK1_NCS, OTG_HS_ULPI_D3, ETH_MII_RX_ER, LCD_G4, EVENTOUT	-
N8	K5	R13	80	91	R13	PB11	I/O	FT	-	TIM2_CH4, I2C2_SDA, USART3_RX, OTG_HS_ULPI_D4, ETH_MII_TX_EN/ETH_R MII_TX_EN, DSIHOST_TE, LCD_G5, EVENTOUT	-
N9	N4	M10	81	92	L11	VCAP1	S	-	-	-	-
M9	P4	-	-	93	K9	VSS	S	-	-	-	-
L9	P3	N10	82	94	L10	VDD	S	-	-	-	-
-	-	-	-	95	M14	PJ5	I/O	FT	-	LCD_R6, EVENTOUT	-
-	-	M11	83	96	P13	PH6	I/O	FT	-	I2C2_SMBA, SPI5_SCK, TIM12_CH1, ETH_MII_RXD2, FMC_SDNE1, DCMI_D8, EVENTOUT	-
-	-	N12	84	97	N13	PH7	I/O	FT	-	I2C3_SCL, SPI5_MISO, ETH_MII_RXD3, FMC_SDCKE1, DCMI_D9, EVENTOUT	-
H8	M5	-	-	98	P14	PH8	I/O	FT	-	I2C3_SDA, FMC_D16, DCMI_HSYNC, LCD_R2, EVENTOUT	-
H9	L5	-	-	99	N14	PH9	I/O	FT	-	I2C3_SMBA, TIM12_CH2, FMC_D17, DCMI_D0, LCD_R3, EVENTOUT	-
J9	M4	-	-	100	P15	PH10	I/O	FT	-	TIM5_CH1, FMC_D18, DCMI_D1, LCD_R4, EVENTOUT	-

Table 10. STM32F469xx pin and ball definitions (continued)

Pin Number						Pin name (function after reset) ⁽¹⁾	Pin types	I/O structures	Notes	Alternate functions	Additional functions
UFBGA169	WLCSP168	UFBGA176	LQFP176	LQFP208	TFBGA216						
K9	N3	-	-	101	N15	PH11	I/O	FT	-	TIM5_CH2, FMC_D19, DCMI_D2, LCD_R5, EVENTOUT	-
H10	P2	-	-	102	M15	PH12	I/O	FT	-	TIM5_CH3, FMC_D20, DCMI_D3, LCD_R6, EVENTOUT	-
-	H7	-	-	-	K10	VSS	S	-	-	-	-
-	-	-	-	103	K11	VDD	S	-	-	-	-
N10	H5	P12	85	104	L13	PB12	I/O	FT	-	TIM1_BKIN, I2C2_SMBA, SPI2_NSS/I2S2_WS, USART3_CK, CAN2_RX, OTG_HS_ULPI_D5, ETH_MII_TXD0/ETH_RMII_TXD0, OTG_HS_ID, EVENTOUT	-
N11	K4	P13	86	105	K14	PB13	I/O	FT	-	TIM1_CH1N, SPI2_SCK/I2S2_CK, USART3_CTS, CAN2_TX, OTG_HS_ULPI_D6, ETH_MII_TXD1/ETH_RMII_TXD1, EVENTOUT	OTG_HS_VBUS
N12	P1	R14	87	106	R14	PB14	I/O	FT	-	TIM1_CH2N, TIM8_CH2N, SPI2_MISO, I2S2ext_SD, USART3_RTS, TIM12_CH1, OTG_HS_DM, EVENTOUT	-
N13	N2	R15	88	107	R15	PB15	I/O	FT	-	RTC_REFIN, TIM1_CH3N, TIM8_CH3N, SPI2_MOSI/I2S2_SD, TIM12_CH2, OTG_HS_DP, EVENTOUT	-
L10	L4	P15	89	108	L15	PD8	I/O	FT	-	USART3_TX, FMC_D13, EVENTOUT	-
M10	N1	P14	90	109	L14	PD9	I/O	FT	-	USART3_RX, FMC_D14, EVENTOUT	-
L11	M3	N15	91	110	K15	PD10	I/O	FT	-	USART3_CK, FMC_D15, LCD_B3, EVENTOUT	-

Table 10. STM32F469xx pin and ball definitions (continued)

Pin Number						Pin name (function after reset) ⁽¹⁾	Pin types	I/O structures	Notes	Alternate functions	Additional functions
UFBGA169	WLCSP168	UFBGA176	LQFP176	LQFP208	TFBGA216						
M11	J4	N14	92	111	N10	PD11	I/O	FT	-	USART3_CTS, QUADSPI_BK1_IO0, FMC_A16/FMC_CLE, EVENTOUT	-
M13	M2	N13	93	112	M10	PD12	I/O	FT	-	TIM4_CH1, USART3_RTS, QUADSPI_BK1_IO1, FMC_A17/FMC_ALE, EVENTOUT	-
M12	H4	M15	94	113	M11	PD13	I/O	FT	-	TIM4_CH2, QUADSPI_BK1_IO3, FMC_A18, EVENTOUT	-
J10	M1	-	95	114	J10	VSS	S	-	-	-	-
K10	-	J13	96	115	J11	VDD	S	-	-	-	-
L12	L3	M14	97	116	L12	PD14	I/O	FT	-	TIM4_CH3, FMC_D0, EVENTOUT	-
L13	L2	L14	98	117	K13	PD15	I/O	FT	-	TIM4_CH4, FMC_D1, EVENTOUT	-
K13	L1	J12	99	118	H11	VDDDSI	S	-	-	-	-
-	-	-	-	-	H10	VSS	S	-	-	-	-
K12	K1	K12	100	119	K12	VCAPDSI	S	-	-	-	-
-	K2	D13	-	-	G13	VDD12DSI	S	-	-	-	-
J12	K3	M12	101	120	J12	DSIHOST_D0P	I/O	-	-	-	-
J13	J3	M13	102	121	J13	DSIHOST_D0N	I/O	-	-	-	-
K11	H1	H12	103	122	G12	VSSDSI	S	-	-	-	-
H12	J1	L12	104	123	H12	DSIHOST_CKP	I/O	-	-	-	-
H13	J2	L13	105	124	H13	DSIHOST_CKN	I/O	-	-	-	-
J11	-	D13	106	125	-	VDD12DSI	S	-	-	-	-
G12	H3	E12	107	126	F12	DSIHOST_D1P	I/O	-	-	-	-
G13	H2	E13	108	127	F13	DSIHOST_D1N	I/O	-	-	-	-
H11	-	H12	109	128	-	VSSDSI	S	-	-	-	-
F13	G5	L15	110	129	M13	PG2	I/O	FT	-	FMC_A12, EVENTOUT	-
F12	G4	K15	111	130	M12	PG3	I/O	FT	-	FMC_A13, EVENTOUT	-
E13	G2	K14	112	131	N12	PG4	I/O	FT	-	FMC_A14/FMC_BA0, EVENTOUT	-

Table 10. STM32F469xx pin and ball definitions (continued)

Pin Number						Pin name (function after reset) ⁽¹⁾	Pin types	I/O structures	Notes	Alternate functions	Additional functions
UFBGA169	WLCSP168	UFBGA176	LQFP176	LQFP208	TFBGA216						
E12	G1	K13	113	132	N11	PG5	I/O	FT	-	FMC_A15/FMC_BA1, EVENTOUT	-
F11	G3	J15	114	133	J15	PG6	I/O	FT	-	DCMI_D12, LCD_R7, EVENTOUT	-
E11	H6	J14	115	134	J14	PG7	I/O	FT	-	SAI1_MCLK_A, USART6_CK, FMC_INT, DCMI_D13, LCD_CLK, EVENTOUT	-
D13	G6	H14	116	135	H14	PG8	I/O	FT	-	SPI6_NSS, USART6_RTS, ETH_PPS_OUT, FMC_SDCLK, LCD_G7, EVENTOUT	-
G9	F2	G12	117	136	G10	VSS	S	-	-	-	-
G11	F1	H13	118	137	G11	VDDUSB	S	-	-	-	-
F9	F3	H15	119	138	H15	PC6	I/O	FT	-	TIM3_CH1, TIM8_CH1, I2S2_MCK, USART6_TX, SDIO_D6, DCMI_D0, LCD_HSYNC, EVENTOUT	-
F10	G7	G15	120	139	G15	PC7	I/O	FT	-	TIM3_CH2, TIM8_CH2, I2S3_MCK, USART6_RX, SDIO_D7, DCMI_D1, LCD_G6, EVENTOUT	-
E10	F4	G14	121	140	G14	PC8	I/O	FT	-	TRACED1, TIM3_CH3, TIM8_CH3, USART6_CK, SDIO_D0, DCMI_D2, EVENTOUT	-
G10	F5	F14	122	141	F14	PC9	I/O	FT	-	MCO2, TIM3_CH4, TIM8_CH4, I2C3_SDA, I2S_CKIN, QUADSPI_BK1_IO0, SDIO_D1, DCMI_D3, EVENTOUT	-
D8	E1	F15	123	142	F15	PA8	I/O	FT	-	MCO1, TIM1_CH1, I2C3_SCL, USART1_CK, OTG_FS_SOF, LCD_R6, EVENTOUT	-
E8	E2	E15	124	143	E15	PA9	I/O	FT	-	TIM1_CH2, I2C3_SMBA, SPI2_SCK/I2S2_CK, USART1_TX, DCMI_D0, EVENTOUT	OTG_FS_VBUS

Table 10. STM32F469xx pin and ball definitions (continued)

Pin Number						Pin name (function after reset) ⁽¹⁾	Pin types	I/O structures	Notes	Alternate functions	Additional functions
UFBGA169	WLCSP168	UFBGA176	LQFP176	LQFP208	TFBGA216						
E9	E3	D15	125	144	D15	PA10	I/O	FT	-	TIM1_CH3, USART1_RX, OTG_FS_ID, DCMI_D1, EVENTOUT	-
A13	F7	C15	126	145	C15	PA11	I/O	FT	-	TIM1_CH4, USART1_CTS, CAN1_RX, OTG_FS_DM, LCD_R4, EVENTOUT	-
A12	F6	B15	127	146	B15	PA12	I/O	FT	-	TIM1_ETR, USART1_RTS, CAN1_TX, OTG_FS_DP, LCD_R5, EVENTOUT	-
A11	D1	A15	128	147	A15	PA13(JTMS- SWDIO)	I/O	FT	-	JTMS-SWDIO, EVENTOUT	-
D12	D2	F13	129	148	E11	VCAP2	S	-	-	-	-
D11	C1	F12	130	149	F10	VSS	S	-	-	-	-
D10	C2	G13	131	150	F11	VDD	S	-	-	-	-
D9	B1	-	-	151	E12	PH13	I/O	FT	-	TIM8_CH1N, CAN1_TX, FMC_D21, LCD_G2, EVENTOUT	-
C13	D3	-	-	152	E13	PH14	I/O	FT	-	TIM8_CH2N, FMC_D22, DCMI_D4, LCD_G3, EVENTOUT	-
C12	E4	-	-	153	D13	PH15	I/O	FT	-	TIM8_CH3N, FMC_D23, DCMI_D11, LCD_G4, EVENTOUT	-
B13	E5	E14	132	154	E14	PI0	I/O	FT	-	TIM5_CH4, SPI2_NSS/I2S2_WS ⁽⁶⁾ , FMC_D24, DCMI_D13, LCD_G5, EVENTOUT	-
C11	C3	D14	133	155	D14	PI1	I/O	FT	-	SPI2_SCK/I2S2_CK ⁽⁶⁾ , FMC_D25, DCMI_D8, LCD_G6, EVENTOUT	-
B12	A1	-	NC (7)	156	C14	PI2	I/O	FT	-	TIM8_CH4, SPI2_MISO, I2S2ext_SD, FMC_D26, DCMI_D9, LCD_G7, EVENTOUT	-
B10	B2	C13	134	157	C13	PI3	I/O	FT	-	TIM8_ETR, SPI2_MOSI/I2S2_SD, FMC_D27, DCMI_D10, EVENTOUT	-
-	-	D9	135	-	F9	VSS	S	-	-	-	-

Table 10. STM32F469xx pin and ball definitions (continued)

Pin Number						Pin name (function after reset) ⁽¹⁾	Pin types	I/O structures	Notes	Alternate functions	Additional functions
UFBGA169	WLCSP168	UFBGA176	LQFP176	LQFP208	TFBGA216						
-	B5	C9	136	158	E10	VDD	S	-	-	-	-
A10	D4	A14	137	159	A14	PA14(JTCK- SWCLK)	I/O	FT	-	JTCK-SWCLK, EVENTOUT	-
B11	A2	A13	138	160	A13	PA15(JTDI)	I/O	FT	-	JTDI, TIM2_CH1/TIM2_ETR, SPI1_NSS, SPI3_NSS/I2S3_WS, EVENTOUT	-
C10	D5	B14	139	161	B14	PC10	I/O	FT	-	SPI3_SCK/I2S3_CK, USART3_TX, UART4_TX, QUADSPI_BK1_IO1, SDIO_D2, DCMI_D8, LCD_R2, EVENTOUT	-
B9	B3	B13	140	162	B13	PC11	I/O	FT	-	I2S3ext_SD, SPI3_MISO, USART3_RX, UART4_RX, QUADSPI_BK2_NCS, SDIO_D3, DCMI_D4, EVENTOUT	-
A9	C4	A12	141	163	A12	PC12	I/O	FT	-	TRACED3, SPI3_MOSI/I2S3_SD, USART3_CK, UART5_TX, SDIO_CK, DCMI_D9, EVENTOUT	-
C9	E6	B12	142	164	B12	PD0	I/O	FT	-	CAN1_RX, FMC_D2, EVENTOUT	-
C7	A3	C12	143	165	C12	PD1	I/O	FT	-	CAN1_TX, FMC_D3, EVENTOUT	-
B8	C5	D12	144	166	D12	PD2	I/O	FT	-	TRACED2, TIM3_ETR, UART5_RX, SDIO_CMD, DCMI_D11, EVENTOUT	-
C8	D6	D11	145	167	C11	PD3	I/O	FT	-	SPI2_SCK/I2S2_CK, USART2_CTS, FMC_CLK, DCMI_D5, LCD_G7, EVENTOUT	-
C6	B4	D10	146	168	D11	PD4	I/O	FT	-	USART2_RTS, FMC_NOE, EVENTOUT	-
B7	C6	C11	147	169	C10	PD5	I/O	FT	-	USART2_TX, FMC_NWE, EVENTOUT	-
F8	A4	D8	148	170	F8	VSS	S	-	-	-	-
F7	-	C8	149	171	E9	VDD	S	-	-	-	-

Table 10. STM32F469xx pin and ball definitions (continued)

Pin Number						Pin name (function after reset) ⁽¹⁾	Pin types	I/O structures	Notes	Alternate functions	Additional functions
UFBGA169	WLCSP168	UFBGA176	LQFP176	LQFP208	TFBGA216						
D7	E7	B11	150	172	B11	PD6	I/O	FT	-	SPI3_MOSI/I2S3_SD, SAI1_SD_A, USART2_RX, FMC_NWAIT, DCMI_D10, LCD_B2, EVENTOUT	-
A8	A5	A11	151	173	A11	PD7	I/O	FT	-	USART2_CK, FMC_NE1, EVENTOUT	-
-	-	-	-	174	B10	PJ12	I/O	FT	-	LCD_G3, LCD_B0, EVENTOUT	-
-	-	-	-	175	B9	PJ13	I/O	FT	-	LCD_G4, LCD_B1, EVENTOUT	-
-	-	-	-	176	C9	PJ14	I/O	FT	-	LCD_B2, EVENTOUT	-
-	-	-	-	177	D10	PJ15	I/O	FT	-	LCD_B3, EVENTOUT	-
E6	D7	C10	152	178	D9	PG9	I/O	FT	-	USART6_RX, QUADSPI_BK2_IO2, FMC_NE2/FMC_NCE, DCMI_VSYNC, EVENTOUT	-
E7	C7	B10	153	179	C8	PG10	I/O	FT	-	LCD_G3, FMC_NE3, DCMI_D2, LCD_B2, EVENTOUT	-
B6	B6	B9	154	180	B8	PG11	I/O	FT	-	ETH_MII_TX_EN/ETH_R MII_TX_EN, DCMI_D3, LCD_B3, EVENTOUT	-
A7	A6	B8	155	181	C7	PG12	I/O	FT	-	SPI6_MISO, USART6_RTS, LCD_B4, FMC_NE4, LCD_B1, EVENTOUT	-
A6	E8	A8	156	182	B3	PG13	I/O	FT	-	TRACED0, SPI6_SCK, USART6_CTS, ETH_MII_TXD0/ETH_RMI I_TXD0, FMC_A24, LCD_R0, EVENTOUT	-
-	-	A7	157	183	A4	PG14	I/O	FT	-	TRACED1, SPI6_MOSI, USART6_TX, QUADSPI_BK2_IO3, ETH_MII_TXD1/ETH_RMI I_TXD1, FMC_A25, LCD_B0, EVENTOUT	-
-	B7	D7	158	184	F7	VSS	S	-	-	-	-
-	A7	C7	159	185	E8	VDD	S	-	-	-	-

Table 10. STM32F469xx pin and ball definitions (continued)

Pin Number						Pin name (function after reset) ⁽¹⁾	Pin types	I/O structures	Notes	Alternate functions	Additional functions
UFBGA169	WLCSP168	UFBGA176	LQFP176	LQFP208	TFBGA216						
-	-	-	-	186	D8	PK3	I/O	FT	-	LCD_B4, EVENTOUT	-
-	-	-	-	187	D7	PK4	I/O	FT	-	LCD_B5, EVENTOUT	-
-	-	-	-	188	C6	PK5	I/O	FT	-	LCD_B6, EVENTOUT	-
-	-	-	-	189	C5	PK6	I/O	FT	-	LCD_B7, EVENTOUT	-
-	-	-	-	190	C4	PK7	I/O	FT	-	LCD_DE, EVENTOUT	-
F6	D8	B7	160	191	B7	PG15	I/O	FT	-	USART6_CTS, FMC_SDNCA5, DCMI_D13, EVENTOUT	-
B5	A8	A10	161	192	A10	PB3(JTDO/TRACESWO)	I/O	FT	-	JTDO/TRACESWO, TIM2_CH2, SPI1_SCK, SPI3_SCK/I2S3_CK, EVENTOUT	-
D6	C8	A9	162	193	A9	PB4(NJTRST)	I/O	FT	-	NJTRST, TIM3_CH1, SPI1_MISO, SPI3_MISO, I2S3ext_SD, EVENTOUT	-
D5	B8	A6	163	194	A8	PB5	I/O	FT	-	TIM3_CH2, I2C1_SMBA, SPI1_MOSI, SPI3_MOSI/I2S3_SD, CAN2_RX, OTG_HS_ULPI_D7, ETH_PPS_OUT, FMC_SDCKE1, DCMI_D10, LCD_G7, EVENTOUT	-
C5	G8	B6	164	195	B6	PB6	I/O	FT	-	TIM4_CH1, I2C1_SCL, USART1_TX, CAN2_TX, QUADSPI_BK1_NCS, FMC_SDNE1, DCMI_D5, EVENTOUT	-
B4	A9	B5	165	196	B5	PB7	I/O	FT	-	TIM4_CH2, I2C1_SDA, USART1_RX, FMC_NL, DCMI_VSYNC, EVENTOUT	-
A5	F8	D6	166	197	E6	BOOT0	I	B	-	-	VPP
D4	B9	A5	167	198	A7	PB8	I/O	FT	-	TIM4_CH3, TIM10_CH1, I2C1_SCL, CAN1_RX, ETH_MII_TXD3, SDIO_D4, DCMI_D6, LCD_B6, EVENTOUT	-

Table 10. STM32F469xx pin and ball definitions (continued)

Pin Number						Pin name (function after reset) ⁽¹⁾	Pin types	I/O structures	Notes	Alternate functions	Additional functions
UFBGA169	WLCSP168	UFBGA176	LQFP176	LQFP208	TFBGA216						
C4	E9	B4	168	199	B4	PB9	I/O	FT	-	TIM4_CH4, TIM11_CH1, I2C1_SDA, SPI2_NSS/I2S2_WS, CAN1_TX, SDIO_D5, DCMI_D7, LCD_B7, EVENTOUT	-
A4	A10	A4	169	200	A6	PE0	I/O	FT	-	TIM4_ETR, UART8_Rx, FMC_NBL0, DCMI_D2, EVENTOUT	-
A3	C9	A3	170	201	A5	PE1	I/O	FT	-	UART8_Tx, FMC_NBL1, DCMI_D3, EVENTOUT	-
E3	B10	D5	-	202	F6	VSS	S	-	-	-	-
C3	D9	C6	171	203	E5	PDR_ON	S	-	-	-	-
D3	A11	C5	172	204	E7	VDD	S	-	-	-	-
B3	D10	D4	173	205	C3	PI4	I/O	FT	-	TIM8_BKIN, FMC_NBL2, DCMI_D5, LCD_B4, EVENTOUT	-
A2	C10	C4	174	206	D3	PI5	I/O	FT	-	TIM8_CH1, FMC_NBL3, DCMI_VSYNC, LCD_B5, EVENTOUT	-
A1	B11	C3	175	207	D6	PI6	I/O	FT	-	TIM8_CH2, FMC_D28, DCMI_D6, LCD_B6, EVENTOUT	-
B1	A12	C2	176	208	D4	PI7	I/O	FT	-	TIM8_CH3, FMC_D29, DCMI_D7, LCD_B7, EVENTOUT	-

1. Function availability depends on the chosen device.

- PC13, PC14, PC15 and PI8 are supplied through the power switch. Since the switch only sinks a limited amount of current (3 mA), the use of GPIOs PC13 to PC15 and PI8 in output mode is limited:
 - The speed should not exceed 2 MHz with a maximum load of 30 pF.
 - These I/Os must not be used as a current source (e.g. to drive an LED).
- Main function after the first backup domain power-up. Later on, it depends on the contents of the RTC registers even after reset (because these registers are not reset by the main reset). For details on how to manage these I/Os, refer to the RTC register description sections in the STM32F4xx reference manual, available from the STMicroelectronics website: www.st.com.
- FT = 5 V tolerant except when in analog mode or oscillator mode (for PC14, PC15, PH0 and PH1).
- If the device is delivered in an WLCSP168, UFBGA169, UFBGA176, LQFP176 or TFBGA216 package, and the BYPASS_REG pin is set to VDD (Regulator OFF/internal reset ON mode), then PA0 is used as an internal Reset (active low).
- PI0 and PI1 cannot be used for I2S2 full-duplex mode.
- NC (not-connected) pins are not bonded. They must be configured by software to output push-pull and forced to 0 in the output data register to avoid extra current consumption in low power modes.

Table 11. FMC pin definition

Pin name	NOR/PSRAM/SRAM	NOR/PSRAM Mux	NAND16	SDRAM
PF0	A0	-	-	A0
PF1	A1	-	-	A1
PF2	A2	-	-	A2
PF3	A3	-	-	A3
PF4	A4	-	-	A4
PF5	A5	-	-	A5
PF12	A6	-	-	A6
PF13	A7	-	-	A7
PF14	A8	-	-	A8
PF15	A9	-	-	A9
PG0	A10	-	-	A10
PG1	A11	-	-	A11
PG2	A12	-	-	A12
PG3	A13	-	-	
PG4	A14	-	-	BA0
PG5	A15	-	-	BA1
PD11	A16	A16	CLE	-
PD12	A17	A17	ALE	-
PD13	A18	A18	-	-
PE3	A19	A19	-	-
PE4	A20	A20	-	-
PE5	A21	A21	-	-
PE6	A22	A22	-	-
PE2	A23	A23	-	-
PG13	A24	A24	-	-
PG14	A25	A25	-	-
PD14	D0	DA0	D0	D0
PD15	D1	DA1	D1	D1
PD0	D2	DA2	D2	D2
PD1	D3	DA3	D3	D3
PE7	D4	DA4	D4	D4
PE8	D5	DA5	D5	D5
PE9	D6	DA6	D6	D6
PE10	D7	DA7	D7	D7

Table 11. FMC pin definition (continued)

Pin name	NOR/PSRAM/SRAM	NOR/PSRAM Mux	NAND16	SDRAM
PE11	D8	DA8	D8	D8
PE12	D9	DA9	D9	D9
PE13	D10	DA10	D10	D10
PE14	D11	DA11	D11	D11
PE15	D12	DA12	D12	D12
PD8	D13	DA13	D13	D13
PD9	D14	DA14	D14	D14
PD10	D15	DA15	D15	D15
PH8	D16	-	-	D16
PH9	D17	-	-	D17
PH10	D18	-	-	D18
PH11	D19	-	-	D19
PH12	D20	-	-	D20
PH13	D21	-	-	D21
PH14	D22	-	-	D22
PH15	D23	-	-	D23
PI0	D24	-	-	D24
PI1	D25	-	-	D25
PI2	D26	-	-	D26
PI3	D27	-	-	D27
PI6	D28	-	-	D28
PI7	D29	-	-	D29
PI9	D30	-	-	D30
PI10	D31	-	-	D31
PD7	NE1	NE1	-	-
PG9	NE2	NE2	NCE	-
PG10	NE3	NE3	-	-
PG11	-	-	-	-
PG12	NE4	-	-	-
PD3	CLK	CLK	-	-
PD4	NOE	NOE	NOE	-
PD5	NWE	NWE	NWE	-
PD6	NWAIT	NWAIT	NWAIT	-
PB7	NADV	NADV	-	-

Table 11. FMC pin definition (continued)

Pin name	NOR/PSRAM/SRAM	NOR/PSRAM Mux	NAND16	SDRAM
PF6	-	-	-	-
PF7	-	-	-	-
PF8	-	-	-	-
PF9	-	-	-	-
PF10	-	-	-	-
PG6	-	-	-	-
PG7	-	-	INT	-
PE0	NBL0	NBL0	-	-
PE1	NBL1	NBL1	-	NBL1
PI4	NBL2	-	-	NBL2
PI5	NBL3	-	-	NBL3
PG8	-	-	-	SDCLK
PC0	-	-	-	SDNWE
PF11	-	-	-	SDNRAS
PG15	-	-	-	SDNCAS
PH2	-	-	-	SDCKE0
PH3	-	-	-	SDNE0
PH6	-	-	-	SDNE1
PH7	-	-	-	SDCKE1
PH5	-	-	-	SDNWE
PC2	-	-	-	SDNE0
PC3	-	-	-	SDCKE0
PB5	-	-	-	SDCKE1
PB6	-	-	-	SDNE1

Table 12. Alternate function

Port	AF0	AF1	AF2	AF3	AF4	AF5	AF6	AF7	AF8	AF9	AF10	AF11	
	SYS	TIM1/2	TIM3/4/5	TIM8/9/10/11	I2C1/2/3	SPI1/2/3/4/5/6	SPI2/3/SA1	SPI2/3/USART1/2/3	USART6/UART4/5/7/8	CAN1/2/TIM12/13/14/QUADSPI/LCD	QUADSPI/OTG_HS/_FS	ETH	
Port A	PA0	-	TIM2_CH1/TIM2_ETR	TIM5_CH1	TIM8_ETR	-	-	-	USART2_CTS	UART4_TX	-	-	ETH_MII_C
	PA1	-	TIM2_CH2	TIM5_CH2	-	-	-	-	USART2_RTS	UART4_RX	QUADSPI_BK1_IO3	-	ETH_MII_RCLK/ETH_FLI_REF_CL
	PA2	-	TIM2_CH3	TIM5_CH3	TIM9_CH1	-	-	-	USART2_TX	-	-	-	ETH_MDI
	PA3	-	TIM2_CH4	TIM5_CH4	TIM9_CH2	-	-	-	USART2_RX	-	LCD_B2	OTG_HS_ULPI_D0	ETH_MII_C
	PA4	-	-	-	-	-	SPI1_NSS	SPI3_NSS/I2S3_WS	USART2_CK	-	-	-	-
	PA5	-	TIM2_CH1/TIM2_ETR	-	TIM8_CH1N	-	SPI1_SCK	-	-	-	-	OTG_HS_ULPI_CK	-
	PA6	-	TIM1_BKIN	TIM3_CH1	TIM8_BK1N	-	SPI1_MISO	-	-	-	TIM13_CH1	-	-
	PA7	-	TIM1_CH1N	TIM3_CH2	TIM8_CH1N	-	SPI1_MOSI	-	-	-	TIM14_CH1	QUADSPI_CLK	ETH_MII_RDV/ETH_RI_CRS_DV
	PA8	MCO1	TIM1_CH1	-	-	I2C3_SCL	-	-	USART1_CK	-	-	OTG_FS_SOF	-
	PA9	-	TIM1_CH2	-	-	I2C3_SMBA	SPI2_SCK/I2S2_CK	-	USART1_TX	-	-	-	-
	PA10	-	TIM1_CH3	-	-	-	-	-	USART1_RX	-	-	OTG_FS_ID	-
	PA11	-	TIM1_CH4	-	-	-	-	-	USART1_CTS	-	CAN1_RX	OTG_FS_DM	-
	PA12	-	TIM1_ETR	-	-	-	-	-	USART1_RTS	-	CAN1_TX	OTG_FS_DP	-
	PA13	JTMS-SWDIO	-	-	-	-	-	-	-	-	-	-	-
	PA14	JTCK-SWCLK	-	-	-	-	-	-	-	-	-	-	-
PA15	JTDI	TIM2_CH1/TIM2_ETR	-	-	-	SPI1_NSS	SPI3_NSS/I2S3_WS	-	-	-	-	-	

Table 12. Alternate function (continued)

Port	AF0	AF1	AF2	AF3	AF4	AF5	AF6	AF7	AF8	AF9	AF10	AF11	
	SYS	TIM1/2	TIM3/4/ 5	TIM8/9/ 10/11	I2C1/2/3	SPI1/2/3 /4/5/6	SPI2/3/ SA1	SPI2/3/ USART 1/2/3	USAR T6/UA RT4/5 /7/8	CAN1/2/ TIM12/1 3/14/QU ADSPI/L CD	QUAD SPI/OT G2_HS /OTG1 _FS	ETH	
Port B	PB0	-	TIM1_CH2N	TIM3_CH3	TIM8_CH2 N	-	-	-	-	-	LCD_R3	OTG_HS _ULPI_D1	ETH_MII RXD2
	PB1	-	TIM1_CH3N	TIM3_CH4	TIM8_CH3 N	-	-	-	-	-	LCD_R6	OTG_HS _ULPI_D2	ETH_MII RXD3
	PB2	-	-	-	-	-	-	-	-	-	-	-	-
	PB3	JTDO/T RACES WO	TIM2_CH2	-	-	-	SPI1_SCK	SPI3_SCK/ I2S3_CK	-	-	-	-	-
	PB4	NJTRST	-	TIM3_CH1	-	-	SPI1_MISO	SPI3_MIS O	I2S3ext_S D	-	-	-	-
	PB5	-	-	TIM3_CH2	-	I2C1_SMBA	SPI1_MOSI	SPI3_MOS /I2S3_SD	-	-	CAN2_RX	OTG_HS _ULPI_D7	ETH_PP S_OUT
	PB6	-	-	TIM4_CH1	-	I2C1_SCL	-	-	USART1_T X	-	CAN2_TX	QUADSPI _BK1_NC S	-
	PB7	-	-	TIM4_CH2	-	I2C1_SDA	-	-	USART1_ RX	-	-	-	-
	PB8	-	-	TIM4_CH3	TIM10_CH 1	I2C1_SCL	-	-	-	-	CAN1_RX	-	ETH_MII TXD3
	PB9	-	-	TIM4_CH4	TIM11_CH 1	I2C1_SDA	SPI2_NSS/ I2S2_WS	-	-	-	CAN1_TX	-	-
	PB10	-	TIM2_CH3	-	-	I2C2_SCL	SPI2_SCK/ I2S2_CK	-	USART3_T X	-	QUADSPI _BK1_NCS	OTG_HS _ULPI_D3	ETH_MII_R _ER
	PB11	-	TIM2_CH4	-	-	I2C2_SDA	-	-	USART3_ RX	-	-	OTG_HS _ULPI_D4	ETH_MII_T EN/ETH_R _TX_EN
	PB12	-	TIM1_BKIN	-	-	I2C2_SMBA	SPI2_NSS/ I2S2_WS	-	USART3_ CK	-	CAN2_RX	OTG_HS _ULPI_D5	ETH_MII_T 0/ETH_RM _XD0
	PB13	-	TIM1_CH1N	-	-	-	SPI2_SCK/ I2S2_CK	-	USART3_ CTS	-	CAN2_TX	OTG_HS _ULPI_D6	ETH_MII_T 1/ETH_RM _XD1
	PB14	-	TIM1_CH2N	-	TIM8_CH2 N	-	SPI2_MISO	I2S2ext_S D	USART3_ RTS	-	TIM12_CH1	-	-
PB15	RTC_RE FIN	TIM1_CH3N	-	TIM8_CH3 N	-	SPI2_MOSI /I2S2_SD	-	-	-	TIM12_CH2	-	-	

Table 12. Alternate function (continued)

Port	AF0	AF1	AF2	AF3	AF4	AF5	AF6	AF7	AF8	AF9	AF10	AF11	
	SYS	TIM1/2	TIM3/4/ 5	TIM8/9/ 10/11	I2C1/2/3	SPI1/2/3 /4/5/6	SPI2/3/ SAI1	SPI2/3/ USART 1/2/3	USAR T6/UA RT4/5 /7/8	CAN1/2/ TIM12/1 3/14/QU ADSPI/L CD	QUAD SPI/OT G2_HS /OTG1 _FS	ETH	
Port C	PC0	-	-	-	-	-	-	-	-	-	-	OTG_HS _ULPI_ST P	-
	PC1	TRACED 0	-	-	-	-	SPI2_MOSI /I2S2_SD	SAI1_SD_ A	-	-	-	-	ETH_MD
	PC2	-	-	-	-	-	SPI2_MISO	I2S2ext_S D	-	-	-	OTG_HS _ULPI_DI R	ETH_MII_T 2
	PC3	-	-	-	-	-	SPI2_MOSI /I2S2_SD	-	-	-	-	OTG_HS _ULPI_N XT	ETH_MII_T CLK
	PC4	-	-	-	-	-	-	-	-	-	-	-	ETH_MII_R 0/ETH_RMI XD0
	PC5	-	-	-	-	-	-	-	-	-	-	-	ETH_MII_R 1/ETH_RMI XD1
	PC6	-	-	TIM3_CH1	TIM8_CH1	-	I2S2_MCK	-	-	USART6 _TX	-	-	-
	PC7	-	-	TIM3_CH2	TIM8_CH2	-	-	I2S3_MCK	-	USART6 _RX	-	-	-
	PC8	TRACED 1	-	TIM3_CH3	TIM8_CH3	-	-	-	-	USART6 _CK	-	-	-
	PC9	MCO2	-	TIM3_CH4	TIM8_CH4	I2C3_SDA	I2S_CKIN	-	-	-	QUADSPI_ BK1_IO0	-	-
	PC10	-	-	-	-	-	-	SPI3_SCK/ I2S3_CK	USART3_ TX	UART4_ TX	QUADSPI_ BK1_IO1	-	-
	PC11	-	-	-	-	-	I2S3ext_SD	SPI3_MIS O	USART3_ RX	UART4_ RX	QUADSPI_ BK2_NCS	-	-
	PC12	TRACED 3	-	-	-	-	-	SPI3_MOS /I2S3_SD	USART3_ CK	UART5_ TX	-	-	-
	PC13	-	-	-	-	-	-	-	-	-	-	-	-
	PC14	-	-	-	-	-	-	-	-	-	-	-	-
	PC15	-	-	-	-	-	-	-	-	-	-	-	-

Table 12. Alternate function (continued)

Port	AF0	AF1	AF2	AF3	AF4	AF5	AF6	AF7	AF8	AF9	AF10	AF11	
	SYS	TIM1/2	TIM3/4/ 5	TIM8/9/ 10/11	I2C1/2/3	SPI1/2/3 /4/5/6	SPI2/3/ SAI1	SPI2/3/ USART 1/2/3	USAR T6/UA RT4/5 /7/8	CAN1/2/ TIM12/1 3/14/QU ADSPI/L CD	QUAD SPI/OT G2_HS /OTG1 _FS	ETH	
Port D	PD0	-	-	-	-	-	-	-	-	-	CAN1_RX	-	-
	PD1	-	-	-	-	-	-	-	-	-	CAN1_TX	-	-
	PD2	TRACED 2	-	TIM3_ETR	-	-	-	-	-	UART5_ RX	-	-	-
	PD3	-	-	-	-	-	SPI2_SCK/ 2S2_CK	-	USART2_ CTS	-	-	-	-
	PD4	-	-	-	-	-	-	-	USART2_ RTS	-	-	-	-
	PD5	-	-	-	-	-	-	-	USART2_ TX	-	-	-	-
	PD6	-	-	-	-	-	SPI3_MOSI /I2S3_SD	SAI1_SD_ A	USART2_ RX	-	-	-	-
	PD7	-	-	-	-	-	-	-	USART2_ CK	-	-	-	-
	PD8	-	-	-	-	-	-	-	USART3_ TX	-	-	-	-
	PD9	-	-	-	-	-	-	-	USART3_ RX	-	-	-	-
	PD10	-	-	-	-	-	-	-	USART3_ CK	-	-	-	-
	PD11	-	-	-	-	-	-	-	USART3_ CTS	-	QUADSPI_ BK1_IO0	-	-
	PD12	-	-	TIM4_CH1	-	-	-	-	USART3_ RTS	-	QUADSPI_ BK1_IO1	-	-
	PD13	-	-	TIM4_CH2	-	-	-	-	-	-	QUADSPI_ BK1_IO3	-	-
	PD14	-	-	TIM4_CH3	-	-	-	-	-	-	-	-	-
PD15	-	-	TIM4_CH4	-	-	-	-	-	-	-	-	-	

Table 12. Alternate function (continued)

Port	AF0	AF1	AF2	AF3	AF4	AF5	AF6	AF7	AF8	AF9	AF10	AF11
	SYS	TIM1/2	TIM3/4/ 5	TIM8/9/ 10/11	I2C1/2/3	SPI1/2/3 /4/5/6	SPI2/3/ SAI1	SPI2/3/ USART 1/2/3	USAR T6/UA RT4/5 /7/8	CAN1/2/ TIM12/1 3/14/QU ADSPI/L CD	QUAD SPI/OT G2_HS /OTG1 _FS	ETH
Port E	PE0	-	-	TIM4_ETR	-	-	-	-	UART8_ Rx	-	-	-
	PE1	-	-	-	-	-	-	-	UART8_ Tx	-	-	-
	PE2	TRACEC LK	-	-	-	-	SPI4_SCK	SAI1_MCL K_A	-	-	QUADSPI_ BK1_IO2	ETH_MII_T 3
	PE3	TRACED 0	-	-	-	-	-	SAI1_SD_ B	-	-	-	-
	PE4	TRACED 1	-	-	-	-	SPI4_NSS	SAI1_FS_ A	-	-	-	-
	PE5	TRACED 2	-	-	TIM9_CH1	-	SPI4_MISO	SAI1_SCK _A	-	-	-	-
	PE6	TRACED 3	-	-	TIM9_CH2	-	SPI4_MOSI	SAI1_SD_ A	-	-	-	-
	PE7	-	TIM1_ETR	-	-	-	-	-	UART7_ Rx	-	QUADSPI_ BK2_IO0	-
	PE8	-	TIM1_CH1N	-	-	-	-	-	UART7_ Tx	-	QUADSPI_ BK2_IO1	-
	PE9	-	TIM1_CH1	-	-	-	-	-	-	-	QUADSPI_ BK2_IO2	-
	PE10	-	TIM1_CH2N	-	-	-	-	-	-	-	QUADSPI_ BK2_IO3	-
	PE11	-	TIM1_CH2	-	-	-	SPI4_NSS	-	-	-	-	-
	PE12	-	TIM1_CH3N	-	-	-	SPI4_SCK	-	-	-	-	-
	PE13	-	TIM1_CH3	-	-	-	SPI4_MISO	-	-	-	-	-
	PE14	-	TIM1_CH4	-	-	-	SPI4_MOSI	-	-	-	-	-
	PE15	-	TIM1_BKIN	-	-	-	-	-	-	-	-	-

Table 12. Alternate function (continued)

Port	AF0	AF1	AF2	AF3	AF4	AF5	AF6	AF7	AF8	AF9	AF10	AF11	
	SYS	TIM1/2	TIM3/4/ 5	TIM8/9/ 10/11	I2C1/2/3	SPI1/2/3 /4/5/6	SPI2/3/ SAI1	SPI2/3/ USART 1/2/3	USAR T6/UA RT4/5 /7/8	CAN1/2/ TIM12/1 3/14/QU ADSPI/L CD	QUAD SPI/OT G2_HS /OTG1 _FS	ETH	
Port F	PF0	-	-	-	-	I2C2_SDA	-	-	-	-	-	-	
	PF1	-	-	-	-	I2C2_SCL	-	-	-	-	-	-	
	PF2	-	-	-	-	I2C2_SMBA	-	-	-	-	-	-	
	PF3	-	-	-	-	-	-	-	-	-	-	-	
	PF4	-	-	-	-	-	-	-	-	-	-	-	
	PF5	-	-	-	-	-	-	-	-	-	-	-	
	PF6	-	-	-	TIM10_CH 1	-	SPI5_NSS	SAI1 SD_B	-	UART7_ Rx	QUADSPI_ BK1_IO3	-	-
	PF7	-	-	-	TIM11_CH 1	-	SPI5_SCK	SAI1 MCLK_B	-	UART7_ Tx	QUADSPI_ BK1_IO2	-	-
	PF8	-	-	-	-	-	SPI5_MISO	SAI1 SCK_B	-	-	TIM13_CH1	QUADSPI_ _BK1_IO0	-
	PF9	-	-	-	-	-	SPI5_MOSI	SAI1 FS_B	-	-	TIM14_CH1	QUADSPI_ _BK1_IO1	-
	PF10	-	-	-	-	-	-	-	-	-	QUADSPI_ CLK	-	-
	PF11	-	-	-	-	-	SPI5_MOSI	-	-	-	-	-	-
	PF12	-	-	-	-	-	-	-	-	-	-	-	-
	PF13	-	-	-	-	-	-	-	-	-	-	-	-
	PF14	-	-	-	-	-	-	-	-	-	-	-	-
PF15	-	-	-	-	-	-	-	-	-	-	-	-	

Table 12. Alternate function (continued)

Port	AF0	AF1	AF2	AF3	AF4	AF5	AF6	AF7	AF8	AF9	AF10	AF11	
	SYS	TIM1/2	TIM3/4/ 5	TIM8/9/ 10/11	I2C1/2/3	SPI1/2/3 /4/5/6	SPI2/3/ SA1	SPI2/3/ USART 1/2/3	USAR T6/UA RT4/5 /7/8	CAN1/2/ TIM12/1 3/14/QU ADSPI/L CD	QUAD SPI/OT G2_HS /OTG1 _FS	ETH	
Port G	PG0	-	-	-	-	-	-	-	-	-	-	-	
	PG1	-	-	-	-	-	-	-	-	-	-	-	
	PG2	-	-	-	-	-	-	-	-	-	-	-	
	PG3	-	-	-	-	-	-	-	-	-	-	-	
	PG4	-	-	-	-	-	-	-	-	-	-	-	
	PG5	-	-	-	-	-	-	-	-	-	-	-	
	PG6	-	-	-	-	-	-	-	-	-	-	-	
	PG7	-	-	-	-	-	-	SAI1_MCL K_A	-	USART6 _CK	-	-	-
	PG8	-	-	-	-	-	SPI6_NSS	-	-	USART6 _RTS	-	-	ETH_PPS_ _T
	PG9	-	-	-	-	-	-	-	-	USART6 _RX	QUADSPI_ BK2_IO2	-	-
	PG10	-	-	-	-	-	-	-	-	-	LCD_G3	-	-
	PG11	-	-	-	-	-	-	-	-	-	-	-	ETH_MII_T EN/ETH_RI _TX_EN
	PG12	-	-	-	-	-	SPI6_MISO	-	-	USART6 _RTS	LCD_B4	-	-
	PG13	TRACED 0	-	-	-	-	SPI6_SCK	-	-	USART6 _CTS	-	-	ETH_MII_T 0/ETH_RMI XD0
	PG14	TRACED 1	-	-	-	-	SPI6_MOSI	-	-	USART6 _TX	QUADSPI_ BK2_IO3	-	-
	PG15	-	-	-	-	-	-	-	-	USART6 _CTS	-	-	-

Table 12. Alternate function (continued)

Port	AF0	AF1	AF2	AF3	AF4	AF5	AF6	AF7	AF8	AF9	AF10	AF11	
	SYS	TIM1/2	TIM3/4/ 5	TIM8/9/ 10/11	I2C1/2/3	SPI1/2/3 /4/5/6	SPI2/3/ SA1	SPI2/3/ USART 1/2/3	USAR T6/UA RT4/5 /7/8	CAN1/2/ TIM12/1 3/14/QU ADSPI/L CD	QUAD SPI/OT G2_HS /OTG1 _FS	ETH	
Port H	PH0	-	-	-	-	-	-	-	-	-	-	-	
	PH1	-	-	-	-	-	-	-	-	-	-	-	
	PH2	-	-	-	-	-	-	-	-	QUADSPI_ BK2_IO0	-	ETH_MII_C	
	PH3	-	-	-	-	-	-	-	-	QUADSPI_ BK2_IO1	-	ETH_MII_C	
	PH4	-	-	-	-	I2C2_SCL	-	-	-	LCD_G5	OTG_HS _ULPI_N XT	-	
	PH5	-	-	-	-	I2C2_SDA	SPI5_NSS	-	-	-	-	-	-
	PH6	-	-	-	-	I2C2_SMBA	SPI5_SCK	-	-	-	TIM12_CH1	-	ETH_MII_R 2
	PH7	-	-	-	-	I2C3_SCL	SPI5_MISO	-	-	-	-	-	ETH_MII_R 3
	PH8	-	-	-	-	I2C3_SDA	-	-	-	-	-	-	-
	PH9	-	-	-	-	I2C3_SMBA	-	-	-	-	TIM12_CH2	-	-
	PH10	-	-	TIM5_CH1	-	-	-	-	-	-	-	-	-
	PH11	-	-	TIM5_CH2	-	-	-	-	-	-	-	-	-
	PH12	-	-	TIM5_CH3	-	-	-	-	-	-	-	-	-
	PH13	-	-	-	TIM8_CH1 N	-	-	-	-	-	CAN1_TX	-	-
	PH14	-	-	-	TIM8_CH2 N	-	-	-	-	-	-	-	-
	PH15	-	-	-	TIM8_CH3 N	-	-	-	-	-	-	-	-

Table 12. Alternate function (continued)

Port	AF0	AF1	AF2	AF3	AF4	AF5	AF6	AF7	AF8	AF9	AF10	AF11
	SYS	TIM1/2	TIM3/4/ 5	TIM8/9/ 10/11	I2C1/2/3	SPI1/2/3 /4/5/6	SPI2/3/ SA1	SPI2/3/ USART 1/2/3	USAR T6/UA RT4/5 /7/8	CAN1/2/ TIM12/1 3/14/QU ADSPI/L CD	QUAD SPI/OT G2_HS /OTG1 _FS	ETH
Port I	PI0	-	-	TIM5_CH4	-	-	SPI2_NSS/ 2S2_WS	-	-	-	-	-
	PI1	-	-	-	-	-	SPI2_SCK/ 2S2_CK	-	-	-	-	-
	PI2	-	-	-	TIM8_CH4	-	SPI2_MISO	I2S2ext_S D	-	-	-	-
	PI3	-	-	-	TIM8_ETR	-	SPI2_MOSI /2S2_SD	-	-	-	-	-
	PI4	-	-	-	TIM8_BK1 N	-	-	-	-	-	-	-
	PI5	-	-	-	TIM8_CH1	-	-	-	-	-	-	-
	PI6	-	-	-	TIM8_CH2	-	-	-	-	-	-	-
	PI7	-	-	-	TIM8_CH3	-	-	-	-	-	-	-
	PI8	-	-	-	-	-	-	-	-	-	-	-
	PI9	-	-	-	-	-	-	-	-	-	CAN1_RX	-
	PI10	-	-	-	-	-	-	-	-	-	-	ETH_MIL R ER
	PI11	-	-	-	-	-	-	-	-	-	LCD_G6	OTG_HS _ULPI _DIR
	PI12	-	-	-	-	-	-	-	-	-	-	-
	PI13	-	-	-	-	-	-	-	-	-	-	-
	PI14	-	-	-	-	-	-	-	-	-	-	-
PI15	-	-	-	-	-	-	-	-	-	LCD_G2	-	

Table 12. Alternate function (continued)

Port	AF0	AF1	AF2	AF3	AF4	AF5	AF6	AF7	AF8	AF9	AF10	AF11
	SYS	TIM1/2	TIM3/4/ 5	TIM8/9/ 10/11	I2C1/2/3	SPI1/2/3 /4/5/6	SPI2/3/ SA1	SPI2/3/ USART 1/2/3	USAR T6/UA RT4/5 /7/8	CAN1/2/ TIM12/1 3/14/QU ADSPI/L CD	QUAD SPI/OT G2_HS /OTG1 _FS	ETH
Port J	PJ0	-	-	-	-	-	-	-	-	LCD_R7	-	-
	PJ1	-	-	-	-	-	-	-	-	-	-	-
	PJ2	-	-	-	-	-	-	-	-	-	-	-
	PJ3	-	-	-	-	-	-	-	-	-	-	-
	PJ4	-	-	-	-	-	-	-	-	-	-	-
	PJ5	-	-	-	-	-	-	-	-	-	-	-
	PJ12	-	-	-	-	-	-	-	-	LCD_G3	-	-
	PJ13	-	-	-	-	-	-	-	-	LCD_G4	-	-
	PJ14	-	-	-	-	-	-	-	-	-	-	-
	PJ15	-	-	-	-	-	-	-	-	-	-	-
Port K	PK3	-	-	-	-	-	-	-	-	-	-	-
	PK4	-	-	-	-	-	-	-	-	-	-	-
	PK5	-	-	-	-	-	-	-	-	-	-	-
	PK6	-	-	-	-	-	-	-	-	-	-	-
	PK7	-	-	-	-	-	-	-	-	-	-	-

Table 13. STM32F469xx register boundary addresses⁽¹⁾

Bus	Boundary address	Peripheral
-	0xE00F FFFF - 0xFFFF FFFF	Reserved
Cortex [®] -M4	0xE000 0000 - 0xE00F FFFF	Cortex [®] -M4 internal peripherals
AHB3	0xD000 0000 - 0xDFFF FFFF	FMC bank 6
	0xC000 0000 - 0xCFFF FFFF	FMC bank 5
	0xA000 1000 - 0xA0001FFF	Quad-SPI control register
	0xA000 2000 - 0xBFFF FFFF	Reserved
	0xA000 0000- 0xA000 0FFF	FMC control register
	0x9000 0000 - 0x9FFF FFFF	Quad-SPI bank
	0x8000 0000 - 0x8FFF FFFF	FMC bank 3
	0x7000 0000 - 0x7FFF FFFF	FMC bank 2 (reserved)
	0x6000 0000 - 0x6FFF FFFF	FMC bank 1
-	0x5006 0C00- 0x5FFF FFFF	Reserved
AHB2	0x5006 0800 - 0x5006 0BFF	RNG
	0x5005 0400 - 0x5006 07FF	Reserved
	0x5005 0000 - 0x5005 03FF	DCMI
	0x5004 0000- 0x5004 FFFF	Reserved
	0x5000 0000 - 0x5003 FFFF	USB OTG FS

Table 13. STM32F469xx register boundary addresses⁽¹⁾ (continued)

Bus	Boundary address	Peripheral
-	0x4008 0000- 0x4FFF FFFF	Reserved
AHB1	0x4004 0000 - 0x4007 FFFF	USB OTG HS
	0x4002 BC00- 0x4003 FFFF	Reserved
	0x4002 B000 - 0x4002 BBFF	Chrom (DMA2D)
	0x4002 9400 - 0x4002 AFFF	Reserved
	0x4002 9000 - 0x4002 93FF	ETHERNET MAC
	0x4002 8C00 - 0x4002 8FFF	
	0x4002 8800 - 0x4002 8BFF	
	0x4002 8400 - 0x4002 87FF	
	0x4002 8000 - 0x4002 83FF	
	0x4002 6800 - 0x4002 7FFF	Reserved
	0x4002 6400 - 0x4002 67FF	DMA2
	0x4002 6000 - 0x4002 63FF	DMA1
	0x4002 5000 - 0x4002 5FFF	Reserved
	0x4002 4000 - 0x4002 4FFF	BKPSRAM
	0x4002 3C00 - 0x4002 3FFF	Flash interface register
	0x4002 3800 - 0x4002 3BFF	RCC
	0x4002 3400 - 0x4002 37FF	Reserved
	0x4002 3000 - 0x4002 33FF	CRC
	0x4002 2C00 - 0x4002 2FFF	Reserved
	0x4002 2800 - 0x4002 2BFF	GPIOK
	0x4002 2400 - 0x4002 27FF	GPIOJ
	0x4002 2000 - 0x4002 23FF	GPIOI
	0x4002 1C00 - 0x4002 1FFF	GPIOH
	0x4002 1800 - 0x4002 1BFF	GPIOG
	0x4002 1400 - 0x4002 17FF	GPIOF
	0x4002 1000 - 0x4002 13FF	GPIOE
	0x4002 0C00 - 0x4002 0FFF	GPIOD
	0x4002 0800 - 0x4002 0BFF	GPIOC
	0x4002 0400 - 0x4002 07FF	GPIOB
	0x4002 0000 - 0x4002 03FF	GPIOA

Table 13. STM32F469xx register boundary addresses⁽¹⁾ (continued)

Bus	Boundary address	Peripheral
APB2	0x4001 7400 - 0x4001 FFFF	Reserved
	0x4001 6C00 - 0x4001 73FF	DSI Host
	0x4001 6800 - 0x4001 6BFF	LCD-TFT
	0x4001 5C00 - 0x4001 67FF	Reserved
	0x4001 5800 - 0x4001 5BFF	SAI1
	0x4001 5400 - 0x4001 57FF	SPI6
	0x4001 5000 - 0x4001 53FF	SPI5
	0x4001 4C00 - 0x4001 4FFF	Reserved
	0x4001 4800 - 0x4001 4BFF	TIM11
	0x4001 4400 - 0x4001 47FF	TIM10
	0x4001 4000 - 0x4001 43FF	TIM9
	0x4001 3C00 - 0x4001 3FFF	EXTI
	0x4001 3800 - 0x4001 3BFF	SYSCFG
	0x4001 3400 - 0x4001 37FF	SPI4
	0x4001 3000 - 0x4001 33FF	SPI1
	0x4001 2C00 - 0x4001 2FFF	SDIO
	0x4001 2400 - 0x4001 2BFF	Reserved
	0x4001 2000 - 0x4001 23FF	ADC1 - ADC2 - ADC3
	0x4001 1800 - 0x4001 1FFF	Reserved
	0x4001 1400 - 0x4001 17FF	USART6
	0x4001 1000 - 0x4001 13FF	USART1
	0x4001 0800 - 0x4001 0FFF	Reserved
	0x4001 0400 - 0x4001 07FF	TIM8
	0x4001 0000 - 0x4001 03FF	TIM1

Table 13. STM32F469xx register boundary addresses⁽¹⁾ (continued)

Bus	Boundary address	Peripheral
-	0x4000 8000- 0x4000 FFFF	Reserved
APB1	0x4000 7C00 - 0x4000 7FFF	UART8
	0x4000 7800 - 0x4000 7BFF	UART7
	0x4000 7400 - 0x4000 77FF	DAC
	0x4000 7000 - 0x4000 73FF	PWR
	0x4000 6C00 - 0x4000 6FFF	Reserved
	0x4000 6800 - 0x4000 6BFF	CAN2
	0x4000 6400 - 0x4000 67FF	CAN1
	0x4000 6000 - 0x4000 63FF	Reserved
	0x4000 5C00 - 0x4000 5FFF	I2C3
	0x4000 5800 - 0x4000 5BFF	I2C2
	0x4000 5400 - 0x4000 57FF	I2C1
	0x4000 5000 - 0x4000 53FF	UART5
	0x4000 4C00 - 0x4000 4FFF	UART4
	0x4000 4800 - 0x4000 4BFF	USART3
	0x4000 4400 - 0x4000 47FF	USART2
	0x4000 4000 - 0x4000 43FF	I2S3ext
	0x4000 3C00 - 0x4000 3FFF	SPI3 / I2S3
	0x4000 3800 - 0x4000 3BFF	SPI2 / I2S2
	0x4000 3400 - 0x4000 37FF	I2S2ext
	0x4000 3000 - 0x4000 33FF	IWDG
	0x4000 2C00 - 0x4000 2FFF	WWDG
	0x4000 2800 - 0x4000 2BFF	RTC & BKP Registers
	0x4000 2400 - 0x4000 27FF	Reserved
	0x4000 2000 - 0x4000 23FF	TIM14
	0x4000 1C00 - 0x4000 1FFF	TIM13
	0x4000 1800 - 0x4000 1BFF	TIM12
	0x4000 1400 - 0x4000 17FF	TIM7
	0x4000 1000 - 0x4000 13FF	TIM6
	0x4000 0C00 - 0x4000 0FFF	TIM5
	0x4000 0800 - 0x4000 0BFF	TIM4
0x4000 0400 - 0x4000 07FF	TIM3	
0x4000 0000 - 0x4000 03FF	TIM2	

1. The reserved boundary address are shown in grayed cells

5 Electrical characteristics

5.1 Parameter conditions

Unless otherwise specified, all voltages are referenced to V_{SS} .

5.1.1 Minimum and maximum values

Unless otherwise specified the minimum and maximum values are guaranteed in the worst conditions of ambient temperature, supply voltage and frequencies by tests in production on 100% of the devices with an ambient temperature at $T_A = 25\text{ °C}$ and $T_A = T_{Amax}$ (given by the selected temperature range).

Data based on characterization results, design simulation and/or technology characteristics are indicated in the table footnotes and are not tested in production. Based on characterization, the minimum and maximum values refer to sample tests and represent the mean value plus or minus three times the standard deviation ($\text{mean} \pm 3\sigma$).

5.1.2 Typical values

Unless otherwise specified, typical data are based on $T_A = 25\text{ °C}$, $V_{DD} = 3.3\text{ V}$ (for the $1.7\text{ V} \leq V_{DD} \leq 3.6\text{ V}$ voltage range). They are given only as design guidelines and are not tested.

Typical ADC accuracy values are determined by characterization of a batch of samples from a standard diffusion lot over the full temperature range, where 95% of the devices have an error less than or equal to the value indicated ($\text{mean} \pm 2\sigma$).

5.1.3 Typical curves

Unless otherwise specified, all typical curves are given only as design guidelines and are not tested.

5.1.4 Loading capacitor

The loading conditions used for pin parameter measurement are shown in [Figure 20](#).

5.1.5 Pin input voltage

The input voltage measurement on a pin of the device is described in [Figure 21](#).

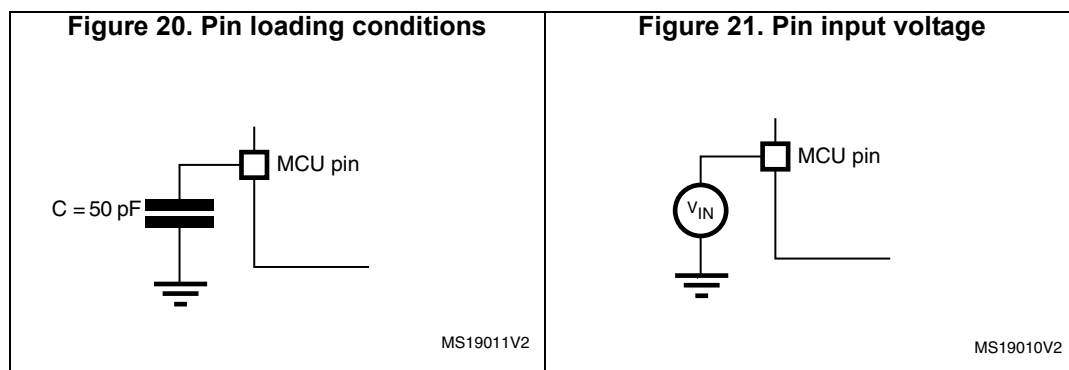

5.1.7 Current consumption measurement

Figure 23. Current consumption measurement scheme

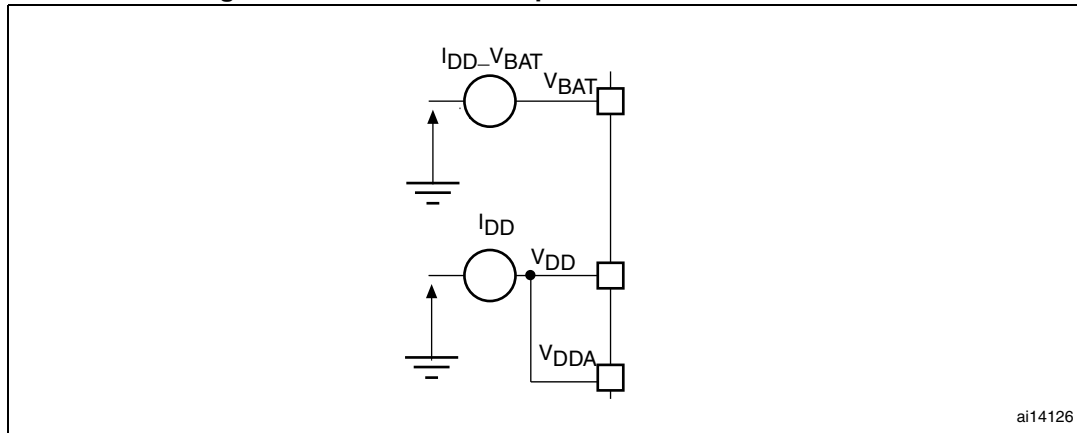

ai14126

5.2 Absolute maximum ratings

Stresses above the absolute maximum ratings listed in [Table 14](#), [Table 15](#), and [Table 16](#) may cause permanent damage to the device. These are stress ratings only and functional operation of the device at these conditions is not implied. Exposure to maximum rating conditions for extended periods may affect device reliability.

Table 14. Voltage characteristics

Symbol	Ratings	Min	Max	Unit
$V_{DD}-V_{SS}$	External main supply voltage (including V_{DDA} , V_{DD} , V_{DDUSB} , V_{DDDSI} and V_{BAT}) ⁽¹⁾	- 0.3	4.0	V
V_{IN}	Input voltage on FT pins ⁽²⁾	$V_{SS} - 0.3$	$V_{DD}+4.0$	
	Input voltage on TTa pins	$V_{SS} - 0.3$	4.0	
	Input voltage on any other pin	$V_{SS} - 0.3$	4.0	
	Input voltage on BOOT pin	V_{SS}	9.0	
$ \Delta V_{DDx} $	Variations between different V_{DD} power pins	-	50	mV
$ V_{SSx} - V_{SS} $	Variations between all the different ground pins	-	50	
$V_{ESD(HBM)}$	Electrostatic discharge voltage (human body model)	see Section 5.3.18		

1. All main power (V_{DD} , V_{DDA} , V_{DDUSB} , V_{DDDSI}) and ground (V_{SS} , V_{SSA}) pins must always be connected to the external power supply, in the permitted range.
2. V_{IN} maximum value must always be respected. Refer to [Table 15](#) for the values of the maximum allowed injected current.

Table 15. Current characteristics

Symbol	Ratings	Max.	Unit
ΣI_{VDD}	Total current into sum of all V_{DD_x} power lines (source) ⁽¹⁾	290	mA
ΣI_{VSS}	Total current out of sum of all V_{SS_x} ground lines (sink) ⁽¹⁾	- 290	
ΣI_{VDDUSB}	Total current into V_{DDUSB} power line (source)	25	
I_{VDD}	Maximum current into each V_{DD_x} power line (source) ⁽¹⁾	100	
I_{VSS}	Maximum current out of each V_{SS_x} ground line (sink) ⁽¹⁾	- 100	
I_{IO}	Output current sunk by any I/O and control pin	25	
	Output current sourced by any I/Os and control pin	- 25	
ΣI_{IO}	Total output current sunk by sum of all I/O and control pins ⁽²⁾	120	
	Total output current sunk by sum of all USB I/Os	25	
	Total output current sourced by sum of all I/Os and control pins ⁽²⁾	- 120	
$I_{INJ(PIN)}$ ⁽³⁾	Injected current on FT pins ⁽⁴⁾	- 5/+0	
	Injected current on NRST and BOOT0 pins ⁽⁴⁾		
	Injected current on TTa pins ⁽⁵⁾	±5	
$\Sigma I_{INJ(PIN)}$ ⁽⁵⁾	Total injected current (sum of all I/O and control pins) ⁽⁶⁾	±25	

1. All main power (V_{DD} , V_{DDA}) and ground (V_{SS} , V_{SSA}) pins must always be connected to the external power supply, in the permitted range.
2. This current consumption must be correctly distributed over all I/Os and control pins. The total output current must not be sunk/sourced between two consecutive power supply pins referring to high pin count LQFP packages.
3. Negative injection disturbs the analog performance of the device. See note in [Section 5.3.24](#).
4. Positive injection is not possible on these I/Os and does not occur for input voltages lower than the specified maximum value.
5. A positive injection is induced by $V_{IN} > V_{DDA}$ while a negative injection is induced by $V_{IN} < V_{SS}$. $I_{INJ(PIN)}$ must never be exceeded. Refer to [Table 14](#) for the values of the maximum allowed input voltage.
6. When several inputs are submitted to a current injection, the maximum $\Sigma I_{INJ(PIN)}$ is the absolute sum of the positive and negative injected currents (instantaneous values).

Table 16. Thermal characteristics

Symbol	Ratings	Value	Unit
T_{STG}	Storage temperature range	- 65 to +150	°C
T_J	Maximum junction temperature	125	°C

5.3 Operating conditions

5.3.1 General operating conditions

Table 17. General operating conditions

Symbol	Parameter	Conditions ⁽¹⁾	Min	Typ	Max	Unit	
f _{HCLK}	Internal AHB clock frequency	Power Scale 3 (VOS[1:0] bits in PWR_CR register = 0x01), Regulator ON, over-drive OFF	0	-	120	MHz	
		Power Scale 2 (VOS[1:0] bits in PWR_CR register = 0x10), Regulator ON	Over-drive OFF	0	-		144
			Over-drive ON		-		168
		Power Scale 1 (VOS[1:0] bits in PWR_CR register = 0x11), Regulator ON	Over-drive OFF	0	-		168
Over-drive ON	-		180				
f _{PCLK1}	Internal APB1 clock frequency	Over-drive OFF	0	-	42		
		Over-drive ON	0	-	45		
f _{PCLK2}	Internal APB2 clock frequency	Over-drive OFF	0	-	84		
		Over-drive ON	0	-	90		
V _{DD}	Standard operating voltage	-	1.7 ⁽²⁾	-	3.6	V	
V _{DDA} ⁽³⁾⁽⁴⁾	Analog operating voltage (ADC limited to 1.2 M samples)	Must be the same potential as V _{DD} ⁽⁵⁾	1.7 ⁽²⁾	-	2.4		
	Analog operating voltage (ADC limited to 2.4 M samples)		2.4	-	3.6		
V _{DDUSB}	USB supply voltage (supply voltage for PA11, PA12, PB14 and PB15 pins)	USB not used	1.7	3.3	3.6		
		USB used	3.0	-	3.6		
V _{DDDSI}	DSI system operating voltage	-	1.7 ⁽²⁾	-	3.6		
V _{BAT}	Backup operating voltage	-	1.65	-	3.6		

Table 17. General operating conditions (continued)

Symbol	Parameter	Conditions ⁽¹⁾	Min	Typ	Max	Unit
V ₁₂	Regulator ON: 1.2 V internal voltage on V _{CAP_1} /V _{CAP_2} pins	Power Scale 3 ((VOS[1:0] bits in PWR_CR register = 0x01), 120 MHz HCLK max frequency)	1.08	1.14	1.20	V
		Power Scale 2 ((VOS[1:0] bits in PWR_CR register = 0x10), 144 MHz HCLK max frequency with over-drive OFF or 168 MHz with over-drive ON)	1.20	1.26	1.32	
		Power Scale 1 ((VOS[1:0] bits in PWR_CR register = 0x11), 168 MHz HCLK max frequency with over-drive OFF or 180 MHz with over-drive ON)	1.26	1.32	1.40	
	Regulator OFF: 1.2 V external voltage must be supplied from external regulator on V _{CAP_1} /V _{CAP_2} pins ⁽⁶⁾	Max frequency 120 MHz	1.10	1.14	1.20	
		Max frequency 144 MHz	1.20	1.26	1.32	
		Max frequency 168 MHz	1.26	1.32	1.38	
V _{IN}	Input voltage on RST and FT pins ⁽⁷⁾	2 V ≤ V _{DD} ≤ 3.6 V	- 0.3	-	5.5	V
		V _{DD} ≤ 2 V	- 0.3	-	5.2	
	Input voltage on TTa pins	-	- 0.3	-	V _{DDA} + 0.3	
	Input voltage on BOOT0 pin	-	0	-	9	
P _D	Power dissipation at T _A = 85 °C for suffix 6 or T _A = 105 °C for suffix 7 ⁽⁸⁾	WLCSP168	-	-	645	mW
		UFBGA169	-	-	385	
		LQFP176	-	-	526	
		UFBGA176	-	-	513	
		LQFP208	-	-	1053	
		TFBGA216	-	-	690	
T _A	Ambient temperature for 6 suffix version	Maximum power dissipation	- 40	-	85	°C
		Low power dissipation ⁽⁹⁾	- 40	-	105	
	Ambient temperature for 7 suffix version	Maximum power dissipation	- 40	-	105	
		Low power dissipation ⁽⁹⁾	- 40	-	125	
T _J	Junction temperature range	6 suffix version	- 40	-	105	
		7 suffix version	- 40	-	125	

1. The over-drive mode is not supported at the voltage ranges from 1.7 to 2.1 V.
2. V_{DD}/V_{DDA} minimum value of 1.7 V is obtained with the use of an external power supply supervisor (refer to [Section 2.19.2](#)).
3. When the ADC is used, refer to [Table 77](#).
4. If V_{REF+} pin is present, it must respect the following condition: V_{DDA}-V_{REF+} < 1.2 V.
5. It is recommended to power V_{DD} and V_{DDA} from the same source. A maximum difference of 300 mV between V_{DD} and V_{DDA} can be tolerated during power-up and power-down operation.
6. The over-drive mode is not supported when the internal regulator is OFF.
7. To sustain a voltage higher than V_{DD}+0.3, the internal Pull-up and Pull-Down resistors must be disabled
8. If T_A is lower, higher P_D values are allowed as long as T_J does not exceed T_{Jmax}.
9. In low power dissipation state, T_A can be extended to this range as long as T_J does not exceed T_{Jmax}.

Table 18. Limitations depending on the operating power supply range

Operating power supply range	ADC operation	Maximum Flash memory access frequency with no wait states ($f_{Flashmax}$)	Maximum HCLK frequency vs. Flash memory wait states ⁽¹⁾⁽²⁾	I/O operation	Possible Flash memory operations
$V_{DD} = 1.7$ to 2.1 V ⁽³⁾	Conversion time up to 1.2 Msps	20 MHz ⁽⁴⁾	168 MHz with 8 wait states and over-drive OFF	No I/O compensation	8-bit erase and program operations only
$V_{DD} = 2.1$ to 2.4 V		22 MHz	180 MHz with 8 wait states and over-drive ON		16-bit erase and program operations
$V_{DD} = 2.4$ to 2.7 V	Conversion time up to 2.4 Msps	24 MHz	180 MHz with 7 wait states and over-drive ON	I/O compensation works	16-bit erase and program operations
$V_{DD} = 2.7$ to 3.6 V ⁽⁵⁾		30 MHz	180 MHz with 5 wait states and over-drive ON		32-bit erase and program operations

1. Applicable only when the code is executed from Flash memory. When the code is executed from RAM, no wait state is required.
2. Thanks to the ART accelerator and the 128-bit Flash memory, the number of wait states given here does not impact the execution speed from Flash memory since the ART accelerator allows to achieve a performance equivalent to 0 wait state program execution.
3. V_{DD}/V_{DDA} minimum value of 1.7 V is obtained with the use of an external power supply supervisor (refer to [Section 2.19.2](#)).
4. Prefetch is not available.
5. When V_{DDUSB} is connected to V_{DD} , the voltage range for USB full speed PHYs can drop down to 2.7 V. However the electrical characteristics of D- and D+ pins will be degraded between 2.7 and 3 V.

5.3.2 VCAP1/VCAP2 external capacitor

Stabilization for the main regulator is achieved by connecting an external capacitor C_{EXT} to the VCAP1/VCAP2 pins. C_{EXT} is specified in [Table 19](#).

Figure 24. External capacitor C_{EXT}

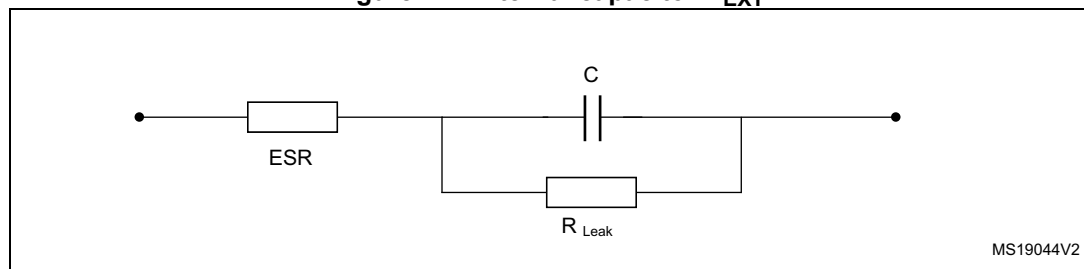

1. Legend: ESR is the equivalent series resistance.

Table 19. VCAP1/VCAP2 operating conditions⁽¹⁾

Symbol	Parameter	Conditions
CEXT	Capacitance of external capacitor	2.2 μ F
ESR	ESR of external capacitor	< 2 Ω

1. When bypassing the voltage regulator, the two 2.2 μ F V_{CAP} capacitors are not required and should be replaced by two 100 nF decoupling capacitors.

5.3.3 Operating conditions at power-up / power-down (regulator ON)

Subject to general operating conditions for T_A .

Table 20. Operating conditions at power-up / power-down (regulator ON)

Symbol	Parameter	Min	Max	Unit
t_{VDD}	V_{DD} rise time rate	20	∞	μ s/V
	V_{DD} fall time rate	20	∞	

5.3.4 Operating conditions at power-up / power-down (regulator OFF)

Subject to general operating conditions for T_A .

Table 21. Operating conditions at power-up / power-down (regulator OFF)⁽¹⁾

Symbol	Parameter	Conditions	Min	Max	Unit
t_{VDD}	V_{DD} rise time rate	Power-up	20	∞	μ s/V
	V_{DD} fall time rate	Power-down	20	∞	
t_{VCAP}	V_{CAP_1} and V_{CAP_2} rise time rate	Power-up	20	∞	
	V_{CAP_1} and V_{CAP_2} fall time rate	Power-down	20	∞	

1. To reset the internal logic at power-down, a reset must be applied on pin PA0 when V_{DD} reach below 1.08 V.

5.3.5 Reset and power control block characteristics

The parameters given in [Table 22](#) are derived from tests performed under ambient temperature and V_{DD} supply voltage conditions summarized in [Table 17](#).

Table 22. Reset and power control block characteristics

Symbol	Parameter	Conditions	Min	Typ	Max	Unit
V_{PVD}	Programmable voltage detector level selection	PLS[2:0]=000 (rising edge)	2.09	2.14	2.19	V
		PLS[2:0]=000 (falling edge)	1.98	2.04	2.08	
		PLS[2:0]=001 (rising edge)	2.23	2.30	2.37	
		PLS[2:0]=001 (falling edge)	2.13	2.19	2.25	
		PLS[2:0]=010 (rising edge)	2.39	2.45	2.51	
		PLS[2:0]=010 (falling edge)	2.29	2.35	2.39	
		PLS[2:0]=011 (rising edge)	2.54	2.60	2.65	
		PLS[2:0]=011 (falling edge)	2.44	2.51	2.56	
		PLS[2:0]=100 (rising edge)	2.70	2.76	2.82	
		PLS[2:0]=100 (falling edge)	2.59	2.66	2.71	
		PLS[2:0]=101 (rising edge)	2.86	2.93	2.99	
		PLS[2:0]=101 (falling edge)	2.65	2.84	2.92	
		PLS[2:0]=110 (rising edge)	2.96	3.03	3.10	
		PLS[2:0]=110 (falling edge)	2.85	2.93	2.99	
		PLS[2:0]=111 (rising edge)	3.07	3.14	3.21	
PLS[2:0]=111 (falling edge)	2.95	3.03	3.09			
$V_{PVDhyst}^{(1)}$	PVD hysteresis	-	-	100	-	mV
$V_{POR/PDR}$	Power-on/power-down reset threshold	Falling edge	1.60	1.68	1.76	V
		Rising edge	1.64	1.72	1.80	
$V_{PDRhyst}^{(1)}$	PDR hysteresis	-	-	40	-	mV
V_{BOR1}	Brownout level 1 threshold	Falling edge	2.13	2.19	2.24	V
		Rising edge	2.23	2.29	2.33	
V_{BOR2}	Brownout level 2 threshold	Falling edge	2.44	2.50	2.56	
		Rising edge	2.53	2.59	2.63	
V_{BOR3}	Brownout level 3 threshold	Falling edge	2.75	2.83	2.88	
		Rising edge	2.85	2.92	2.97	
$V_{BORhyst}^{(1)}$	BOR hysteresis	-	-	100	-	mV
$T_{RSTTEMPO}^{(1)(2)}$	POR reset temporization	-	0.5	1.5	3.0	ms
$I_{RUSH}^{(1)}$	InRush current on voltage regulator power-on (POR or wakeup from Standby)	-	-	160	200	mA
$E_{RUSH}^{(1)}$	InRush energy on voltage regulator power-on (POR or wakeup from Standby)	$V_{DD} = 1.7\text{ V}$, $T_A = 105\text{ °C}$, $I_{RUSH} = 171\text{ mA}$ for $31\text{ }\mu\text{s}$	-	-	5.4	μC

1. Guaranteed by design.

2. The reset temporization is measured from the power-on (POR reset or wakeup from V_{BAT}) to the instant when first instruction is read by the user application code.

5.3.6 Over-drive switching characteristics

When the over-drive mode switches from enabled to disabled or disabled to enabled, the system clock is stalled during the internal voltage set-up.

The over-drive switching characteristics are given in [Table 23](#). They are subject to general operating conditions for T_A .

Table 23. Over-drive switching characteristics⁽¹⁾

Symbol	Parameter	Conditions	Min	Typ	Max	Unit
T _{od_swen}	Over_drive switch enable time	HSI	-	45	-	μs
		HSE max for 4 MHz and min for 26 MHz	45	-	100	
		External HSE 50 MHz	-	40	-	
T _{od_swdis}	Over_drive switch disable time	HSI	-	20	-	
		HSE max for 4 MHz and min for 26 MHz.	20	-	80	
		External HSE 50 MHz	-	15	-	

1. Guaranteed by design.

5.3.7 Supply current characteristics

The current consumption is a function of several parameters and factors such as the operating voltage, ambient temperature, I/O pin loading, device software configuration, operating frequencies, I/O pin switching rate, program location in memory and executed binary code.

The current consumption is measured as described in [Figure 23](#).

All the run-mode current consumption measurements given in this section are performed with a reduced code that gives a consumption equivalent to CoreMark[®] code.

Typical and maximum current consumption

The MCU is placed under the following conditions:

- All I/O pins are in input mode with a static value at V_{DD} or V_{SS} (no load).
- All peripherals are disabled except if it is explicitly mentioned.
- The Flash memory access time is adjusted both to f_{HCLK} frequency and V_{DD} range (see [Table 18: Limitations depending on the operating power supply range](#)).
- When the regulator is OFF, the V_{12} is provided externally, as described in [Table 17: General operating conditions](#).
- The voltage scaling and over-drive mode are adjusted to f_{HCLK} frequency as follows:
 - Scale 3 for $f_{HCLK} \leq 120$ MHz
 - Scale 2 for $120 \text{ MHz} < f_{HCLK} \leq 144$ MHz
 - Scale 1 for $144 \text{ MHz} < f_{HCLK} \leq 180$ MHz. The over-drive is only ON at 180 MHz.
- The system clock is HCLK, $f_{PCLK1} = f_{HCLK}/4$, and $f_{PCLK2} = f_{HCLK}/2$.
- External clock frequency is 25 MHz and PLL is ON when f_{HCLK} is higher than 25 MHz.
- The typical current consumption values are obtained for $1.7 \text{ V} \leq V_{DD} \leq 3.6 \text{ V}$ voltage range and for ambient temperature $T_A = 25 \text{ }^\circ\text{C}$ unless otherwise specified.
- The maximum values are obtained for $1.7 \text{ V} \leq V_{DD} \leq 3.6 \text{ V}$ voltage range and a maximum ambient temperature (T_A), unless otherwise specified.
- For the voltage range $1.7 \text{ V} \leq V_{DD} \leq 2.1 \text{ V}$ the maximum frequency is 168 MHz.

Table 24. Typical and maximum current consumption in Run mode, code with data processing running from Flash memory (ART accelerator enabled except prefetch) or RAM, regulator ON

Symbol	Parameter	Conditions	f _{HCLK} (MHz)	Typ	Max ⁽¹⁾			Unit
					T _A = 25 °C	T _A = 85 °C	T _A = 105 °C	
I _{DD}	Supply current in RUN mode	All Peripherals enabled ⁽²⁾⁽³⁾	180	103	109 ⁽⁴⁾	142	175 ⁽⁴⁾	mA
			168	94	99	124	149	
			150	84	89	114	140	
			144	77	81	104	127	
			120	57	60	79	98	
			90	43	46	64	84	
			60	30	33	51	70	
			30	16	19	37	57	
			25	14	16	34	54	
			16	7	10	28	48	
			8	4	7	26	46	
			4	3	6	24	44	
		2	3	5	23	43		
		All Peripherals disabled ⁽²⁾	180	50	56 ⁽⁴⁾	89	124 ⁽⁴⁾	
			168	45	51	75	102	
			150	41	46	70	97	
			144	37	42	63	88	
			120	28	31	49	69	
			90	21	24	42	63	
			60	15	17	36	56	
			30	9	11	29	49	
			25	7	10	28	48	
			16	4	7	25	45	
			8	3	6	22	44	
4	3		5	23	43			
2	2	5	23	43				

1. Guaranteed based on test during characterization.
2. When analog peripheral blocks such as ADCs, DACs, HSE, LSE, HSI, or LSI are ON, an additional power consumption should be considered.
3. When the ADC is ON (ADON bit set in the ADC_CR2 register), add an additional power consumption of 1.6 mA per ADC for the analog part.
4. Guaranteed by test in production.



Table 25. Typical and maximum current consumption in Run mode, code with data processing running from Flash memory (ART accelerator disabled), regulator ON

Symbol	Parameter	Conditions	f _{HCLK} (MHz)	Typ	Max ⁽¹⁾			Unit
					T _A = 25 °C	T _A = 85 °C	T _A = 105 °C	
I _{DD}	Supply current in RUN mode	All Peripherals enabled ⁽²⁾⁽³⁾	168	97	102	128	154	mA
			150	87	92	118	143	
			144	80	84	108	131	
			120	65	68	88	108	
			90	51	54	73	93	
			60	37	41	59	79	
			30	21	23	42	62	
		25	18	20	39	59		
		All Peripherals disabled	168	49	55	79	105	
			150	44	49	44	100	
			144	40	45	68	92	
			120	36	39	58	78	
			90	29	32	51	71	
			60	22	25	44	64	
30	13		15	34	54			
25	11	13	32	52				

1. Guaranteed based on test during characterization.
2. When analog peripheral blocks such as ADCs, DACs, HSE, LSE, HSI, or LSI are ON, an additional power consumption should be considered.
3. When the ADC is ON (ADON bit set in the ADC_CR2 register), add an additional power consumption of 1.6 mA per ADC for the analog part.

Table 26. Typical and maximum current consumption in Run mode, code with data processing running from Flash memory (ART accelerator enabled except prefetch), regulator OFF

Symbol	Parameter	Conditions	f _{HCLK} (MHz)	Typ		Max ⁽¹⁾						Unit
				I _{DD12}	I _{DD}	T _A = 25 °C		T _A = 85 °C		T _A = 105 °C		
						I _{DD12}	I _{DD}	I _{DD12}	I _{DD}	I _{DD12}	I _{DD}	
I _{DD12} / I _{DD}	Supply current in RUN mode from V ₁₂ and V _{DD} supply	All Peripherals enabled ^{(2) (3)}	168	93	1	98	1	123	1	148	1	mA
			150	83	1	88	1	113	1	138	1	
			144	76	1	80	1	103	1	126	1	
			120	56	1	59	1	78	1	97	1	
			90	43	1	45	1	64	1	83	1	
			60	29	1	32	1	50	1	70	1	
			30	15	1	18	1	36	1	56	1	
		25	13	1	15	1	34	1	53	1		
		All Peripherals disabled	168	44	1	50	1	72	1	94	1	
			150	40	1	45	1	68	1	90	1	
			144	36	1	40	1	62	1	82	1	
			120	27	1	30	1	48	1	66	1	
			90	20	1	23	1	41	1	60	1	
			60	14	1	16	1	35	1	53	1	
30	8		1	10	1	28	1	47	1			
25	7	1	9	1	27	1	46	1				

1. Guaranteed based on test during characterization.
2. When analog peripheral blocks such as ADCs, DACs, HSE, LSE, HSI, or LSI are ON, DSI regulator, an additional power consumption should be considered.
3. When the ADC is ON (ADON bit set in the ADC_CR2 register), add an additional power consumption of 1.6 mA per ADC for the analog part.

Table 27. Typical and maximum current consumption in Sleep mode, regulator ON

Symbol	Parameter	Conditions	f _{HCLK} (MHz)	Typ	Max ⁽¹⁾⁽²⁾⁽³⁾			Unit
					T _A = 25 °C	T _A = 85 °C	T _A = 105 °C	
I _{DD}	Supply current in Sleep mode	All Peripherals enabled	180	78	88 ⁽⁴⁾	118	151 ⁽⁴⁾	mA
			168	71	76	101	127	
			150	64	71	94	119	
			144	58	62	85	109	
			120	43	46	65	85	
			90	33	37	54	74	
			60	23	25	44	63	
			30	13	15	34	53	
			25	11	13	32	52	
			16	5	8	27	47	
			8	4	7	25	45	
			4	3	5	24	44	
		2	2	5	23	43		
		All Peripherals disabled	180	23	29 ⁽⁴⁾	63	96 ⁽⁴⁾	
			168	21	25	50	76	
			150	19	23	48	74	
			144	17	31	43	67	
			120	13	16	34	54	
			90	10	13	31	51	
			60	7	10	28	48	
			30	5	7	25	45	
			25	4	7	25	45	
			16	2	5	23	43	
			8	2	5	23	43	
4	2		5	23	43			
2	2	4	23	42				

1. Guaranteed based on test during characterization.
2. When analog peripheral blocks such as ADCs, DACs, HSE, LSE, HSI, or LSI are ON, an additional power consumption should be considered.
3. When the ADC is ON (ADON bit set in the ADC_CR2 register), add an additional power consumption of 1.6 mA per ADC for the analog part.
4. Guaranteed by test in production.

Table 28. Typical and maximum current consumption in Sleep mode, regulator OFF

Symbol	Parameter	Conditions	f _{HCLK} (MHz)	Typ		Max ⁽¹⁾						Unit
				I _{DD12}	I _{DD}	T _A = 25 °C		T _A = 85 °C		T _A = 105 °C		
						I _{DD12}	I _{DD}	I _{DD12}	I _{DD}	I _{DD12}	I _{DD}	
I _{DD12} / I _{DD}	Supply current in RUN mode from V ₁₂ and V _{DD} supply	All Peripherals enabled	168	70	1	75	1	100	1	126	1	mA
			150	63	1	70	1	93	1	118	1	
			144	57	1	61	1	84	1	108	1	
			120	42	1	45	1	64	1	84	1	
			90	32	1	36	1	53	1	73	1	
			60	22	1	24	1	43	1	63	1	
			30	12	1	14	1	33	1	53	1	
		25	10	1	12	1	31	1	51	1		
		All Peripherals disabled	168	20	1	24	1	49	1	75	1	
			150	18	1	22	1	47	1	73	1	
			144	16	1	19	1	42	1	66	1	
			120	12	1	14	1	33	1	53	1	
			90	10	1	12	1	30	1	50	1	
			60	7	1	9	1	27	1	47	1	
30	4		1	6	1	24	1	44	1			
25	4	1	6	1	24	1	44	1				

1. Guaranteed based on test during characterization.

Table 29. Typical and maximum current consumption in Stop mode

Symbol	Parameter	Conditions	Typ	Max ⁽¹⁾			Unit
				T _A = 25 °C	T _A = 85 °C	T _A = 105 °C	
I _{DD_STOP_NM} (normal mode)	Supply current in Stop mode with voltage regulator in main regulator mode	Flash memory in Stop mode, all oscillators OFF, no independent watchdog	0.63	3	17	33	mA
		Flash memory in Deep power down mode, all oscillators OFF, no independent watchdog	0.58	3	17	33	
	Supply current in Stop mode with voltage regulator in Low Power regulator mode	Flash memory in Stop mode, all oscillators OFF, no independent watchdog	0.50	2	15	28	
		Flash memory in Deep power down mode, all oscillators OFF, no independent watchdog	0.44	2	15	28	
I _{DD_STOP_UDM} (under-drive mode)	Supply current in Stop mode with voltage regulator in main regulator and under-drive mode	Flash memory in Deep power down mode, main regulator in under-drive mode, all oscillators OFF, no independent watchdog	0.21	1	6	12	
	Supply current in Stop mode with voltage regulator in Low Power regulator and under-drive mode	Flash memory in Deep power down mode, Low Power regulator in under-drive mode, all oscillators OFF, no independent watchdog	0.14	1	6	13	

1. Data based on characterization, tested in production.

Table 30. Typical and maximum current consumption in Standby mode

Symbol	Parameter	Conditions	Typ ⁽¹⁾			Max ⁽²⁾			Unit
			T _A = 25 °C			T _A = 25 °C	T _A = 85 °C	T _A = 105 °C	
			V _{DD} = 1.7 V	V _{DD} = 2.4 V	V _{DD} = 3.3 V	V _{DD} = 3.3 V			
I _{DD_STBY}	Supply current in Standby mode	Backup SRAM ON, RTC and LSE oscillator OFF	1.7	2.5	2.9	6 ⁽³⁾	18	35 ⁽³⁾	µA
		Backup SRAM OFF, RTC and LSE oscillator OFF	1.0	1.8	2.20	5 ⁽³⁾	15	30 ⁽³⁾	
		Backup SRAM OFF, RTC ON and LSE oscillator in Power Drive mode	1.7	2.7	3.2	7	20	39	
		Backup SRAM ON, RTC ON and LSE oscillator in Power Drive mode	2.4	3.4	4.0	8	25	48	
		Backup SRAM ON, RTC ON and LSE oscillator in High Drive mode	3.2	4.2	4.8	10	29	57	
		Backup SRAM OFF, RTC ON and LSE oscillator in High Drive mode	2.5	3.5	4.1	8	25	48	

1. PDR is off for V_{DD}=1.7 V. When the PDR is OFF (internal reset OFF), the typical current consumption is reduced by additional 1.2 µA
2. Based on characterization, not tested in production unless otherwise specified.
3. Based on characterization, tested in production.

Table 31. Typical and maximum current consumption in V_{BAT} mode

Symbol	Parameter	Conditions ⁽¹⁾	Typ			Max ⁽²⁾			Unit
			T _A = 25 °C			T _A = 25 °C	T _A = 85 °C	T _A = 105 °C	
			V _{BAT} = 1.7 V	V _{BAT} = 2.4 V	V _{BAT} = 3.3 V	V _{BAT} = 3.3 V			
I _{DD_VBAT}	Backup domain supply current	Backup SRAM ON, RTC ON and LSE oscillator in Low Power mode	1.431	1.577	1.825	1.9	12.0	24.0	µA
		Backup SRAM OFF, RTC ON and LSE oscillator in Low Power mode	0.720	0.849	1.060	1.1	7.0	13.9	
		Backup SRAM ON, RTC ON and LSE oscillator in High Drive mode	2.212	2.368	2.630	2.80	17.3	34.6	
		Backup SRAM OFF, RTC ON and LSE oscillator in High Drive mode	1.499	1.637	1.862	2.0	12.3	24.5	
		Backup SRAM ON, RTC and LSE OFF	0.710	0.720	0.760	0.8 ⁽³⁾	5.0	10.0 ⁽³⁾	
		Backup SRAM OFF, RTC and LSE OFF	0.018	0.020	0.024	0.2 ⁽³⁾	2.0	4.0 ⁽³⁾	

1. Crystal used: Abracon ABS07-120-32.768 kHz-T with a C_L of 6 pF for typical values.
2. Based on characterization, tested in production.
3. Based on test during characterization.

Figure 25. Typical V_{BAT} current consumption (RTC ON / backup SRAM ON and LSE in Low drive mode)

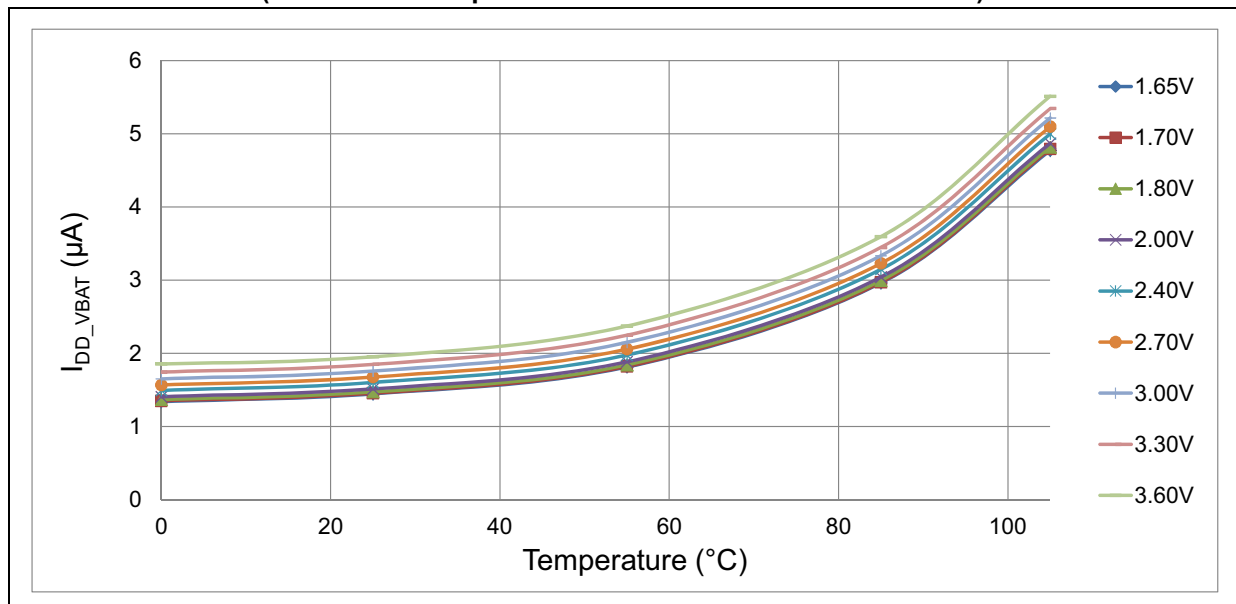
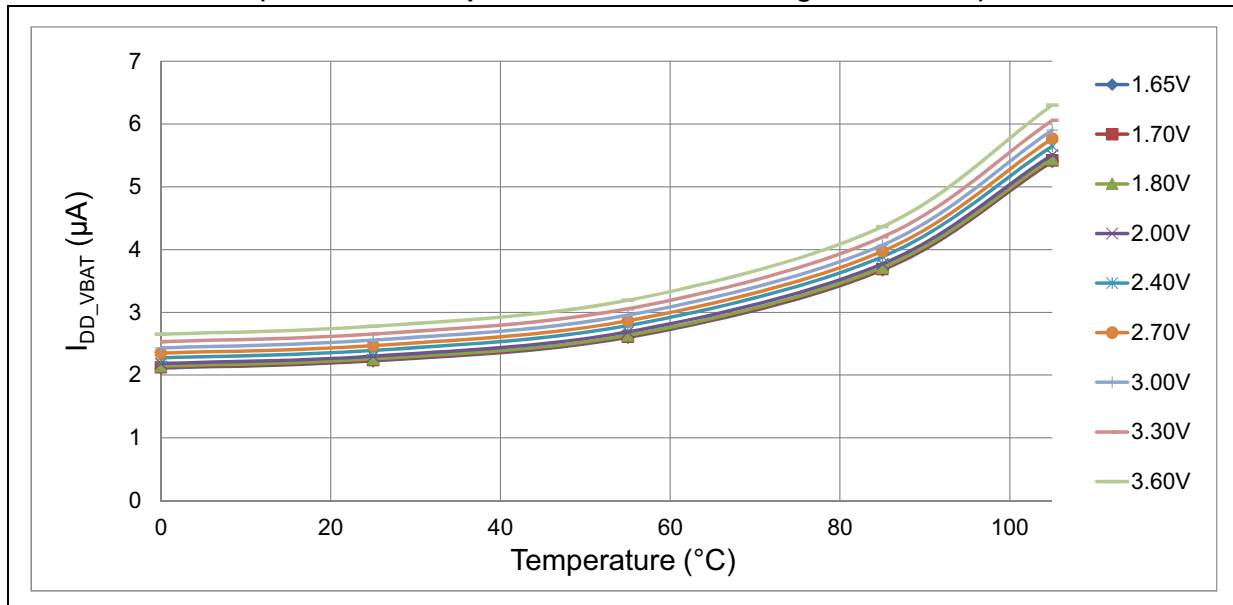

Figure 26. Typical V_{BAT} current consumption (RTC ON / backup SRAM ON and LSE in High drive mode)



I/O system current consumption

The current consumption of the I/O system has two components: static and dynamic.

I/O static current consumption

All the I/Os used as inputs with pull-up generate current consumption when the pin is externally held low. The value of this current consumption can be simply computed by using the pull-up/pull-down resistors values given in [Table 58](#).

For the output pins, any external pull-down or external load must also be considered to estimate the current consumption.

Additional I/O current consumption is due to I/Os configured as inputs if an intermediate voltage level is externally applied. This current consumption is caused by the input Schmitt trigger circuits used to discriminate the input value. Unless this specific configuration is required by the application, this supply current consumption can be avoided by configuring these I/Os in analog mode. This is notably the case of ADC input pins which should be configured as analog inputs.

Caution: Any floating input pin can also settle to an intermediate voltage level or switch inadvertently, as a result of external electromagnetic noise. To avoid current consumption related to floating pins, they must either be configured in analog mode, or forced internally to a definite digital value. This can be done either by using pull-up/down resistors or by configuring the pins in output mode.

I/O dynamic current consumption

In addition to the internal peripheral current consumption (see [Table 33](#)), the I/Os used by an application also contribute to the current consumption. When an I/O pin switches, it uses

the current from the MCU supply voltage to supply the I/O pin circuitry and to charge/discharge the capacitive load (internal or external) connected to the pin:

$$I_{SW} = V_{DD} \times f_{SW} \times C$$

where

I_{SW} is the current sunk by a switching I/O to charge/discharge the capacitive load

V_{DD} is the MCU supply voltage

f_{SW} is the I/O switching frequency

C is the total capacitance seen by the I/O pin: $C = C_{INT} + C_{EXT}$

The test pin is configured in push-pull output mode and is toggled by software at a fixed frequency.

Table 32. Switching output I/O current consumption⁽¹⁾

Symbol	Parameter	Conditions	I/O toggling frequency (fsw)	Typ	Unit
I _{DDIO}	I/O switching Current	V _{DD} = 3.3 V C = C _{INT} ⁽²⁾	2 MHz	0.0	mA
			8 MHz	0.2	
			25 MHz	0.6	
			50 MHz	1.1	
			60 MHz	1.3	
			84 MHz	1.8	
			90 MHz	1.9	
		V _{DD} = 3.3 V C _{EXT} = 0 pF C = C _{INT} + C _{EXT} + C _S	2 MHz	0.1	
			8 MHz	0.4	
			25 MHz	1.23	
			50 MHz	2.43	
			60 MHz	2.93	
			84 MHz	3.86	
			90 MHz	4.07	

Table 32. Switching output I/O current consumption⁽¹⁾ (continued)

Symbol	Parameter	Conditions	I/O toggling frequency (fsw)	Typ	Unit
I _{DDIO}	I/O switching Current	$V_{DD} = 3.3\text{ V}$ $C_{EXT} = 10\text{ pF}$ $C = C_{INT} + C_{EXT} + C_S$	2 MHz	0.18	mA
			8 MHz	0.67	
			25 MHz	2.09	
			50 MHz	3.6	
			60 MHz	4.5	
			84 MHz	7.8	
		$V_{DD} = 3.3\text{ V}$ $C_{EXT} = 22\text{ pF}$ $C = C_{INT} + C_{EXT} + C_S$	2 MHz	0.26	
			8 MHz	1.01	
			25 MHz	3.14	
			50 MHz	6.39	
		$V_{DD} = 3.3\text{ V}$ $C_{EXT} = 33\text{ pF}$ $C = C_{INT} + C_{EXT} + C_S$	60 MHz	10.68	
			2 MHz	0.33	
			8 MHz	1.29	
			25 MHz	4.23	
			50 MHz	11.02	

1. C_S is the PCB board capacitance including the pad pin. C_S = 7 pF (estimated value).
2. This test is performed by cutting the LQFP176 package pin (pad removal).

On-chip peripheral current consumption

The MCU is placed under the following conditions:

- At startup, all I/O pins are in analog input configuration.
- All peripherals are disabled unless otherwise mentioned.
- I/O compensation cell enabled.
- The ART accelerator is ON.
- Scale 1 mode selected, internal digital voltage V12 = 1.32 V.
- HCLK is the system clock. f_{PCLK1} = f_{HCLK}/4, and f_{PCLK2} = f_{HCLK}/2.
 The given value is calculated by measuring the difference of current consumption
 - with all peripherals clocked off
 - with only one peripheral clocked on
 - f_{HCLK} = 180 MHz (Scale1 + over-drive ON), f_{HCLK} = 144 MHz (Scale 2), f_{HCLK} = 120 MHz (Scale 3)
- Ambient operating temperature is 25 °C and V_{DD}=3.3 V.



Table 33. Peripheral current consumption

Peripheral		I _{DD} (Typ) ⁽¹⁾			Unit
		Scale 1	Scale 2	Scale 3	
AHB1 (up to 180 MHz)	GPIOA	3.16	3.00	2.58	μA/MHz
	GPIOB	2.67	2.62	2.25	
	GPIOC	2.42	2.31	2.10	
	GPIOD	2.22	2.10	1.79	
	GPIOE	2.60	2.48	2.23	
	GPIOF	2.39	2.27	2.08	
	GPIOG	2.27	2.13	1.98	
	GPIOH	2.34	2.20	2.02	
	GPIOI	2.52	2.37	2.17	
	GPIOJ	2.16	2.03	1.86	
	GPIOK	2.20	2.06	1.89	
	OTG_HS+ULPI	36.49	33.89	29.90	
	CRC	0.62	0.55	0.50	
	BKPSRAM	0.83	0.74	0.63	
	DMA1 ⁽²⁾	3.3 x N + 6.8	3 x N + 6.3	2.7 x N + 5.5	
	DMA2 ⁽²⁾	3.4 x N + 5.7	3.1 x N + 5.3	2.8 x N + 4.6	
DMA2D	33.33	30.66	26.98		
ETH_MAC ETH_MAC_TX ETH_MAC_RX ETH_MAC_PTP	22.30	20.69	18.19		
AHB2 (up to 180 MHz)	USB_OTG_FS	34.33	31.96	28.35	μA/MHz
	DVCM1	3.61	3.35	2.98	
	RNG	1.94	1.82	1.61	
AHB3 (up to 180 MHz)	QUADSPI	16.83	15.57	13.83	μA/MHz
	FMC	17.22	15.92	14.00	
Bus matrix ⁽³⁾		12.17	11.19	9.97	μA/MHz

Table 33. Peripheral current consumption (continued)

Peripheral		I _{DD} (Typ) ⁽¹⁾			Unit
		Scale 1	Scale 2	Scale 3	
APB1 (up to 45 MHz)	TIM2	19.11	17.56	15.33	μA/MHz
	TIM3	15.62	14.22	12.17	
	TIM4	16.22	14.64	12.83	
	TIM5	18.44	16.72	14.00	
	TIM6	3.18	2.69	2.17	
	TIM7	3.11	2.56	2.00	
	TIM12	8.67	7.56	6.50	
	TIM13	6.11	5.33	4.43	
	TIM14	6.44	5.61	4.67	
	PWR	17.44	15.61	13.53	
	USART2	5.44	4.64	3.93	
	USART3	5.51	4.72	4.00	
	UART4	5.22	4.64	3.83	
	UART5	5.33	4.64	3.83	
	UART7	5.56	4.78	4.10	
	UART8	5.24	4.64	3.93	
	I2C1	4.78	4.08	3.43	
	I2C2	5.11	4.50	3.73	
	I2C3	4.78	4.08	3.43	
	SPI2/I2S2 ⁽⁴⁾	4.11	3.53	3.00	
	SPI3/I2S3 ⁽⁴⁾	4.33	3.67	3.17	
	CAN1	8.89	7.83	6.87	
	CAN2	7.22	6.44	5.50	
DAC ⁽⁵⁾	2.89	2.69	2.40		
WWDG	1.73	1.44	1.00		

Table 33. Peripheral current consumption (continued)

Peripheral		I _{DD} (Typ) ⁽¹⁾			Unit
		Scale 1	Scale 2	Scale 3	
APB2 (up to 90 MHz)	SDIO	7.94	7.18	6.37	μA/MHz
	TIM1	19.44	17.81	15.80	
	TIM8	19.44	17.81	15.80	
	TIM9	8.44	7.60	6.77	
	TIM10	5.67	5.03	4.50	
	TIM11	5.72	5.10	4.55	
	ADC1 ⁽⁶⁾	5.06	4.54	4.05	
	ADC2 ⁽⁶⁾	5.00	4.47	3.97	
	ADC3 ⁽⁶⁾	5.26	4.75	4.17	
	USART1	4.83	4.33	3.83	
	USART6	4.83	4.33	3.83	
	SPI1	2.11	1.76	1.60	
	SPI4	2.11	1.69	1.60	
	SPI5	2.11	1.76	1.60	
	SPI6	2.11	1.76	1.60	
	SYSCFG	1.72	1.35	1.22	
	LTDC	37.61	34.53	30.60	
	SAI1	3.44	3.01	2.72	
DSI	32.98	30.32	26.87		

1. When the I/O compensation cell is ON, I_{DD} typical value increases by 0.22 mA.
2. DMA1/DMA2 current consumption is calculated by the equation. N: is the number of streams enabled, N= [1..8]
3. The BusMatrix is automatically active when at least one master is ON.
4. To enable an I2S peripheral, first set the I2SMOD bit and then the I2SE bit in the SPI_I2SCFGR register.
5. When the DAC is ON and EN1/2 bits are set in DAC_CR register, add an additional power consumption of 0.8 mA per DAC channel for the analog part.
6. When the ADC is ON (ADON bit set in the ADC_CR2 register), add an additional power consumption of 1.6 mA per ADC for the analog part.

5.3.8 Wakeup time from low-power modes

The wakeup times given in [Table 34](#) are measured starting from the wakeup event trigger up to the first instruction executed by the CPU:

- For Stop or Sleep modes: the wakeup event is WFE.
- WKUP (PA0) pin is used to wakeup from Standby, Stop and Sleep modes.

All timings are derived from tests performed under ambient temperature and $V_{DD}=3.3\text{ V}$.

Table 34. Low-power mode wakeup timings

Symbol	Parameter	Conditions	Typ ⁽¹⁾	Max ⁽¹⁾	Unit
$t_{WUSLEEP}^{(2)}$	Wakeup from Sleep	-	5	6	CPU clock cycles
$t_{WUSTOP}^{(2)}$	Wakeup from Stop mode with MR/LP regulator in normal mode	Main regulator is ON	12.9	13.0	μs
		Main regulator is ON and Flash memory in Deep power down mode	105	109	
		Low power regulator is ON	22	25.4	
		Low power regulator is ON and Flash memory in Deep power down mode	114	121	
$t_{WUSTOP}^{(2)}$	Wakeup from Stop mode with MR/LP regulator in Under-drive mode	Main regulator in under-drive mode (Flash memory in Deep power-down mode)	107	111	
		Low power regulator in under-drive mode (Flash memory in Deep power-down mode)	115	121	
$t_{WUSTDBY}^{(2)(3)}$	Wakeup from Standby mode	-	318	371	

1. Based on test during characterization.
2. The wakeup times are measured from the wakeup event to the point in which the application code reads the first
3. $t_{WUSTDBY}$ maximum value is given at $-40\text{ }^{\circ}\text{C}$.

5.3.9 External clock source characteristics

High-speed external user clock generated from an external source

In bypass mode the HSE oscillator is switched off and the input pin is a standard I/O. The external clock signal has to respect the [Table 58](#). However, the recommended clock input waveform is shown in [Figure 27](#).

The characteristics given in [Table 35](#) result from tests performed using an high-speed external clock source, and under ambient temperature and supply voltage conditions

summarized in [Table 17](#).

Table 35. High-speed external user clock characteristics

Symbol	Parameter	Conditions	Min	Typ	Max	Unit
f_{HSE_ext}	External user clock source frequency ⁽¹⁾	-	1	-	50	MHz
V_{HSEH}	OSC_IN input pin high level voltage		$0.7V_{DD}$	-	V_{DD}	V
V_{HSEL}	OSC_IN input pin low level voltage		V_{SS}	-	$0.3V_{DD}$	
$t_{w(HSE)}$ $t_{w(HSE)}$	OSC_IN high or low time ⁽¹⁾		5	-	-	ns
$t_{r(HSE)}$ $t_{f(HSE)}$	OSC_IN rise or fall time ⁽¹⁾		-	-	10	
$C_{in(HSE)}$	OSC_IN input capacitance ⁽¹⁾	-	-	5	-	pF
$DuCy_{(HSE)}$	Duty cycle	-	45	-	55	%
I_L	OSC_IN Input leakage current	$V_{SS} \leq V_{IN} \leq V_{DD}$	-	-	± 1	μA

1. Guaranteed by design.

Low-speed external user clock generated from an external source

In bypass mode the LSE oscillator is switched off and the input pin is a standard I/O. The external clock signal has to respect the [Table 58](#). However, the recommended clock input waveform is shown in [Figure 28](#).

The characteristics given in [Table 36](#) result from tests performed using an low-speed external clock source, and under ambient temperature and supply voltage conditions summarized in [Table 17](#).

Table 36. Low-speed external user clock characteristics

Symbol	Parameter	Conditions	Min	Typ	Max	Unit
f_{LSE_ext}	User External clock source frequency ⁽¹⁾	-	-	32.768	1000	kHz
V_{LSEH}	OSC32_IN input pin high level voltage		$0.7V_{DD}$	-	V_{DD}	
V_{LSEL}	OSC32_IN input pin low level voltage		V_{SS}	-	$0.3V_{DD}$	
$t_{w(LSE)}$ $t_{f(LSE)}$	OSC32_IN high or low time ⁽¹⁾		450	-	-	ns
$t_{r(LSE)}$ $t_{f(LSE)}$	OSC32_IN rise or fall time ⁽¹⁾		-	-	50	
$C_{in(LSE)}$	OSC32_IN input capacitance ⁽¹⁾	-	-	5	-	pF
$DuCy_{(LSE)}$	Duty cycle	-	30	-	70	%
I_L	OSC32_IN Input leakage current	$V_{SS} \leq V_{IN} \leq V_{DD}$	-	-	± 1	μA

1. Guaranteed by design.

Figure 27. High-speed external clock source AC timing diagram

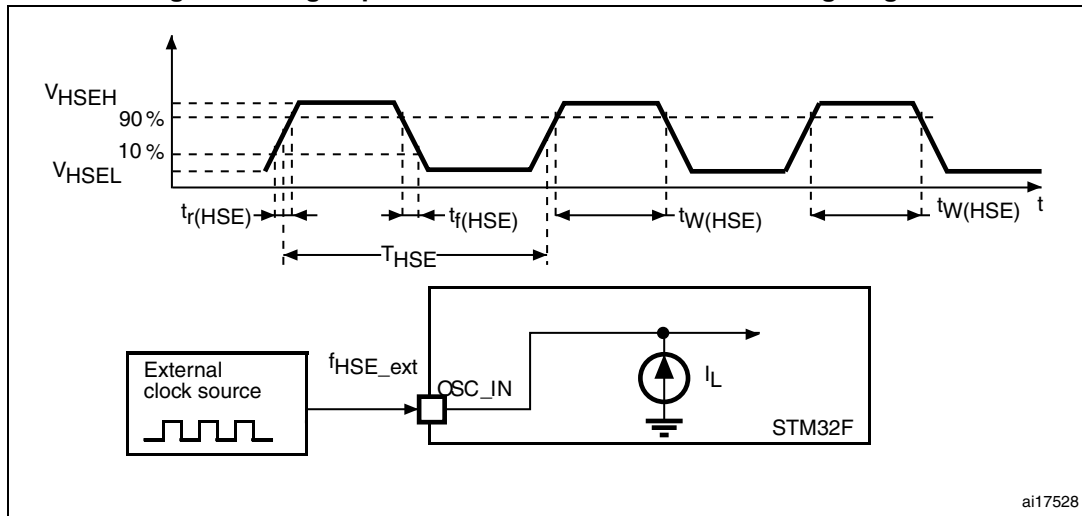

ai17528

Figure 28. Low-speed external clock source AC timing diagram

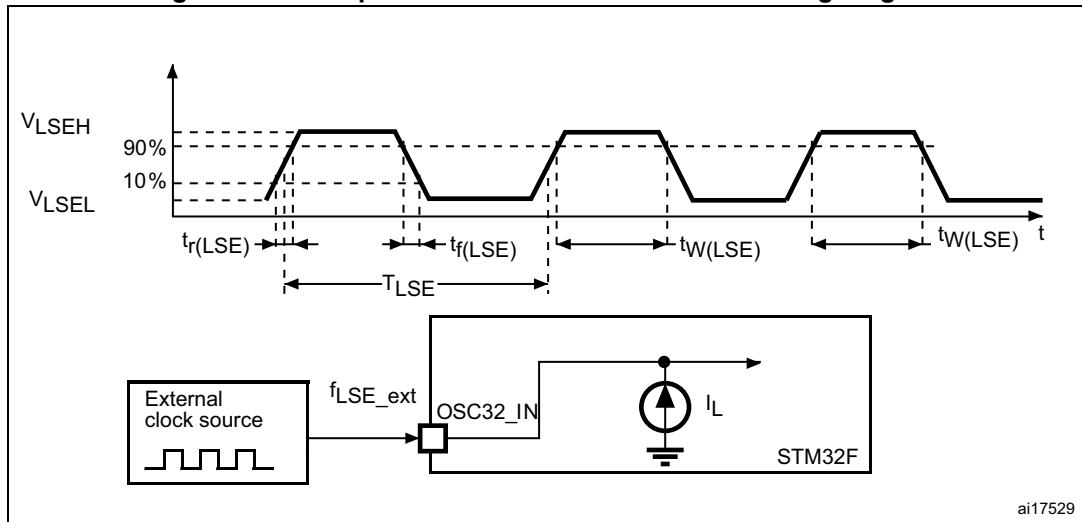

ai17529

High-speed external clock generated from a crystal/ceramic resonator

The high-speed external (HSE) clock can be supplied with a 4 to 26 MHz crystal/ceramic resonator oscillator. All the information given in this paragraph are based on characterization results obtained with typical external components specified in [Table 37](#). In the application, the resonator and the load capacitors have to be placed as close as possible to the oscillator pins in order to minimize output distortion and startup stabilization time. Refer to the crystal resonator manufacturer for more details on the resonator characteristics (frequency, package, accuracy).

Table 37. HSE 4-26 MHz oscillator characteristics ⁽¹⁾

Symbol	Parameter	Conditions	Min	Typ	Max	Unit
f_{OSC_IN}	Oscillator frequency	-	4	-	26	MHz
R_F	Feedback resistor	-	-	200	-	k Ω

Table 37. HSE 4-26 MHz oscillator characteristics ⁽¹⁾ (continued)

Symbol	Parameter	Conditions	Min	Typ	Max	Unit
I _{DD}	HSE current consumption	V _{DD} =3.3 V, ESR= 30 Ω, C _L =5 pF@25 MHz	-	450	-	μA
		V _{DD} =3.3 V, ESR= 30 Ω, C _L =10 pF@25 MHz	-	530	-	
ACC _{HSE} ⁽²⁾	HSE accuracy	-	- 500	-	500	ppm
G _{m_crit_max}	Maximum critical crystal g _m	Startup	-	-	1	mA/V
t _{SU(HSE)} ⁽³⁾	Startup time	V _{DD} is stabilized	-	2	-	ms

1. Guaranteed by design.
2. This parameter depends on the crystal used in the application. The minimum and maximum values must be respected to comply with USB standard specifications.
3. t_{SU(HSE)} is the startup time measured from the moment it is enabled (by software) to a stabilized 8 MHz oscillation is reached. This value is based on characterization and not tested in production. It is measured for a standard crystal resonator and it can vary significantly with the crystal manufacturer.

For C_{L1} and C_{L2}, it is recommended to use high-quality external ceramic capacitors in the 5 pF to 25 pF range (typ.), designed for high-frequency applications, and selected to match the requirements of the crystal or resonator (see [Figure 29](#)). C_{L1} and C_{L2} are usually the same size. The crystal manufacturer typically specifies a load capacitance which is the series combination of C_{L1} and C_{L2}. PCB and MCU pin capacitance must be included (10 pF can be used as a rough estimate of the combined pin and board capacitance) when sizing C_{L1} and C_{L2}.

Note: For information on selecting the crystal, refer to the application note AN2867 “Oscillator design guide for ST microcontrollers” available from www.st.com.

Figure 29. Typical application with an 8 MHz crystal

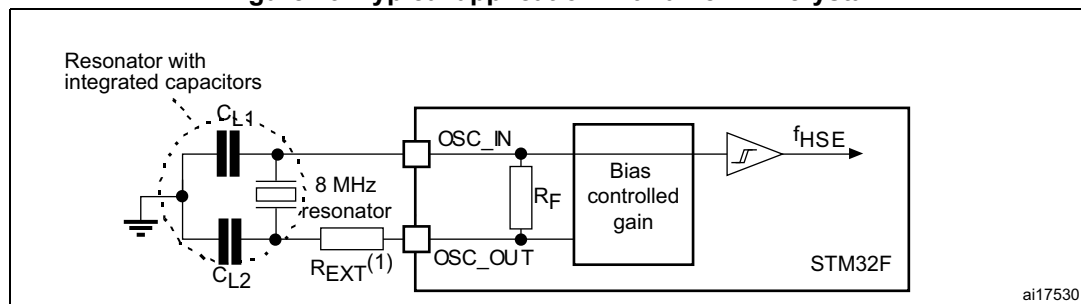

1. R_{EXT} value depends on the crystal characteristics.

Low-speed external clock generated from a crystal/ceramic resonator

The low-speed external (LSE) clock can be supplied with a 32.768 kHz crystal/ceramic resonator oscillator. All the informations given in this paragraph are based on characterization results obtained with typical external components specified in [Table 38](#).

In the application, the resonator and the load capacitors have to be placed as close as possible to the oscillator pins in order to minimize output distortion and startup stabilization time. Refer to the crystal resonator manufacturer for more details on the resonator characteristics (frequency, package, accuracy).

Table 38. LSE oscillator characteristics ($f_{LSE} = 32.768 \text{ kHz}$)⁽¹⁾

Symbol	Parameter	Conditions	Min	Typ	Max	Unit
R_F	Feedback resistor	-	-	18.4	-	M Ω
I_{DD}	LSE current consumption	Low power mode ⁽²⁾	-	-	1	μA
		High drive mode ⁽²⁾	-	-	3	
ACC_{LSE} ⁽³⁾	LSE accuracy	-	- 500	-	500	ppm
$G_{m_crit_max}$	Maximum critical crystal g_m	Low power mode ⁽²⁾	-	-	0.56	$\mu\text{A/V}$
		High drive mode ⁽²⁾	-	-	1.5	
$t_{SU(LSE)}$ ⁽⁴⁾	Startup time	V_{DD} is stabilized	-	2	-	s

1. Guaranteed by design.
2. LSE mode cannot be changed “on the fly” otherwise, a glitch can be generated on OSCIN pin.
3. This parameter depends on the crystal used in the application. Refer to application note AN2867.
4. $t_{SU(LSE)}$ is the startup time measured from the moment it is enabled (by software) to a stabilized 32.768 kHz oscillation is reached. This value is based on characterization and not tested in production. It is measured for a standard crystal resonator and it can vary significantly with the crystal manufacturer.

Note: For information on selecting the crystal, refer to the application note AN2867 “Oscillator design guide for ST microcontrollers” available from www.st.com.

Figure 30. Typical application with a 32.768 kHz crystal

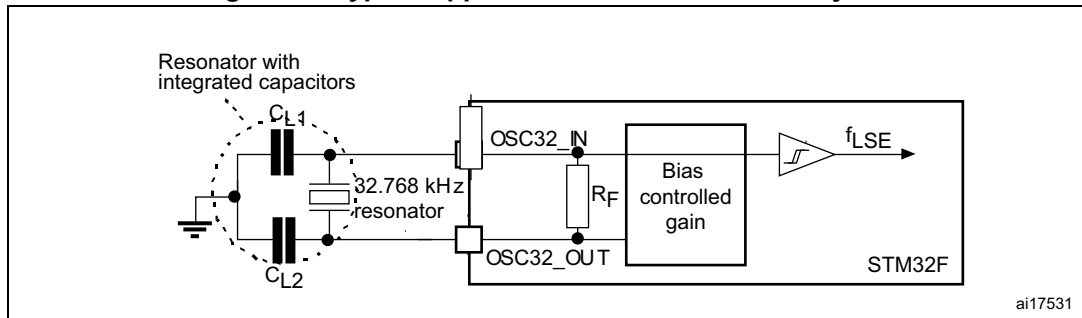

5.3.10 Internal clock source characteristics

The parameters given in [Table 39](#) and [Table 40](#) are derived from tests performed under ambient temperature and V_{DD} supply voltage conditions summarized in [Table 17](#).

High-speed internal (HSI) RC oscillator

Table 39. HSI oscillator characteristics ⁽¹⁾

Symbol	Parameter	Conditions	Min	Typ	Max	Unit
f_{HSI}	Frequency	-	-	16	-	MHz
ACC_{HSI}	HSI user trimming step ⁽²⁾	-	-	-	1	%
	HSI oscillator accuracy	$T_A = -40 \text{ to } 105 \text{ }^\circ\text{C}$ ⁽³⁾	- 8	-	4.5	%
		$T_A = -10 \text{ to } 85 \text{ }^\circ\text{C}$ ⁽³⁾	- 4	-	4	%
		$T_A = 25 \text{ }^\circ\text{C}$ ⁽⁴⁾	- 1	-	1	%

Table 39. HSI oscillator characteristics ⁽¹⁾ (continued)

Symbol	Parameter	Conditions	Min	Typ	Max	Unit
$t_{su(HSI)}$ ⁽²⁾	HSI oscillator startup time	-	-	2.2	4	μs
$I_{DD(HSI)}$ ⁽²⁾	HSI oscillator power consumption	-	-	60	80	μA

1. $V_{DD} = 3.3 V$, $T_A = -40$ to 105 °C unless otherwise specified.
2. Guaranteed by design
3. Based on test during characterization.
4. Factory calibrated, parts not soldered.

Figure 31. HSI deviation vs. temperature

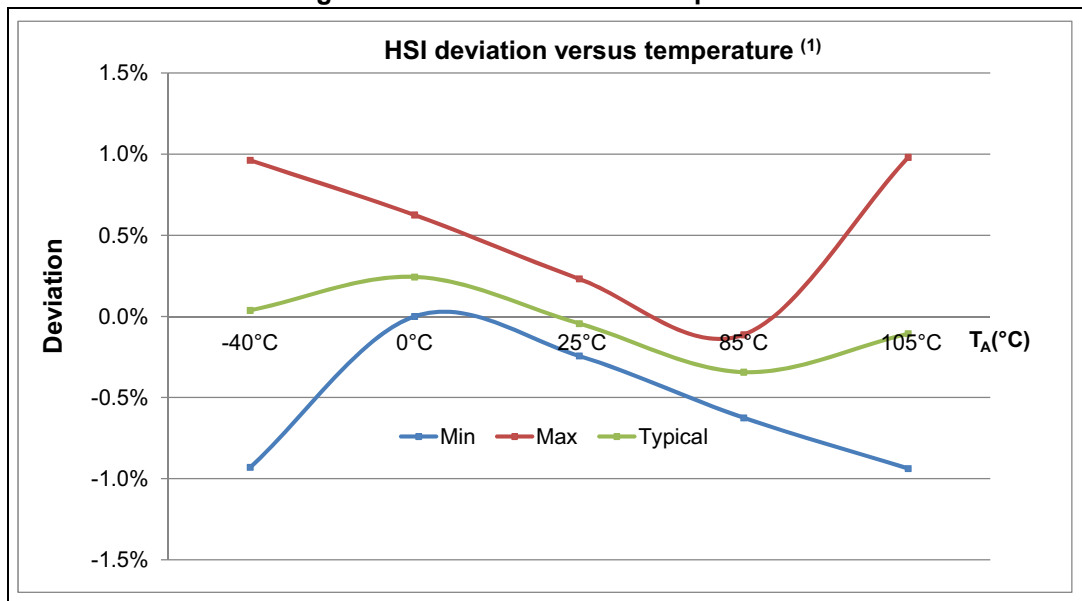

1. Based on test during characterization.

Low-speed internal (LSI) RC oscillator

Table 40. LSI oscillator characteristics (1)

Symbol	Parameter	Min	Typ	Max	Unit
$f_{LSI}^{(2)}$	Frequency	17	32	47	kHz
$t_{su(LSI)}^{(3)}$	Startup time	-	15	40	μs
$I_{DD(LSI)}^{(3)}$	Power consumption	-	0.4	0.6	μA

- $V_{DD} = 3 V, T_A = -40$ to $105\text{ }^{\circ}C$ unless otherwise specified.
- Based on test during characterization.
- Guaranteed by design.

Figure 32. ACC_{LSI} versus temperature

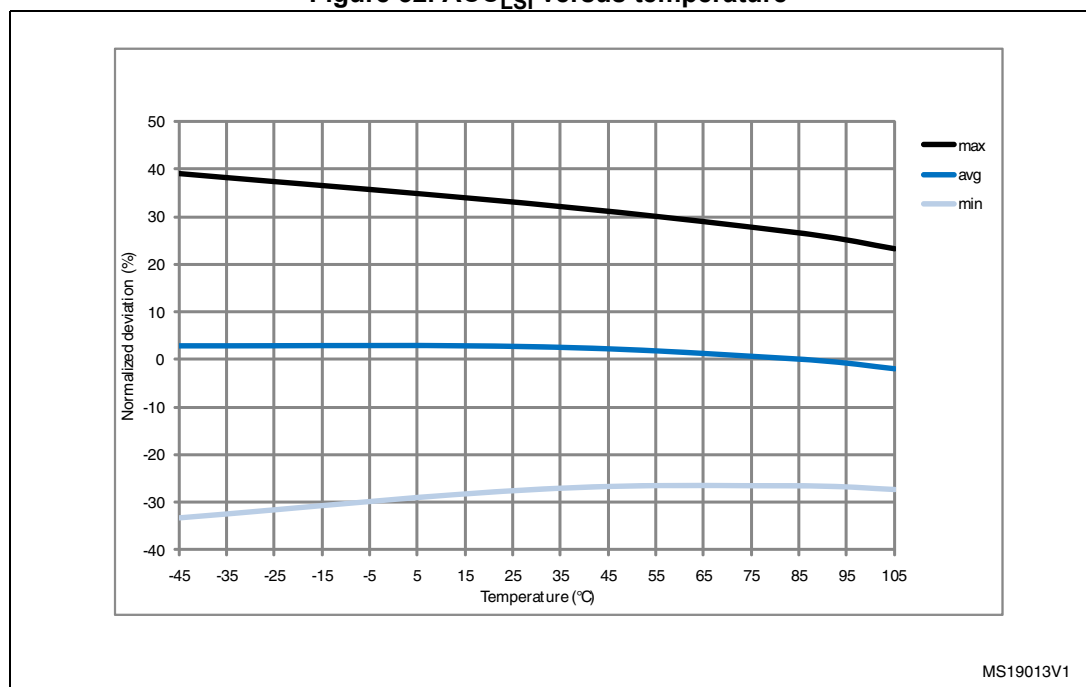

MS19013V1

5.3.11 PLL characteristics

The parameters given in [Table 41](#) and [Table 42](#) are derived from tests performed under temperature and V_{DD} supply voltage conditions summarized in [Table 17](#).

Table 41. Main PLL characteristics

Symbol	Parameter	Conditions	Min	Typ	Max	Unit
f_{PLL_IN}	PLL input clock ⁽¹⁾	-	0.95 ⁽²⁾	1	2.10	MHz
f_{PLL_OUT}	PLL multiplier output clock	-	24	-	180	
f_{PLL48_OUT}	48 MHz PLL multiplier output clock	-	-	48	75	
f_{VCO_OUT}	PLL VCO output	-	192	-	432	

Table 41. Main PLL characteristics (continued)

Symbol	Parameter	Conditions	Min	Typ	Max	Unit	
t _{LOCK}	PLL lock time	VCO freq = 192 MHz	75	-	200	μs	
		VCO freq = 432 MHz	100	-	300		
Jitter ⁽³⁾	Cycle-to-cycle jitter	System clock 120 MHz	RMS	-	25	-	ps
			peak to peak	-	±150	-	
	Period Jitter		RMS	-	15	-	
			peak to peak	-	±200	-	
	Main clock output (MCO) for RMII Ethernet	Cycle to cycle at 50 MHz on 1000 samples	-	32	-		
	Main clock output (MCO) for MII Ethernet	Cycle to cycle at 25 MHz on 1000 samples	-	40	-		
Bit Time CAN jitter	Cycle to cycle at 1 MHz on 1000 samples	-	330	-			
I _{DD(PLL)} ⁽⁴⁾	PLL power consumption on VDD	VCO freq = 192 MHz	0.15	-	0.40	mA	
		VCO freq = 432 MHz	0.45	-	0.75		
I _{DDA(PLL)} ⁽⁴⁾	PLL power consumption on VDDA	VCO freq = 192 MHz	0.30	-	0.40		
		VCO freq = 432 MHz	0.55	-	0.85		

1. Take care of using the appropriate division factor M to obtain the specified PLL input clock values. The M factor is shared between PLL and PLLI2S.
2. Guaranteed by design.
3. The use of 2 PLLs in parallel can degrade the Jitter up to +30%.
4. Based on test during characterization.

Table 42. PLLI2S (audio PLL) characteristics

Symbol	Parameter	Conditions	Min	Typ	Max	Unit	
f _{PLLI2S_IN}	PLLI2S input clock ⁽¹⁾	-	0.95 ⁽²⁾	1	2.10	MHz	
f _{PLLI2S_OUT}	PLLI2S multiplier output clock	-	-	-	216		
f _{VCO_OUT}	PLLI2S VCO output	-	192	-	432		
t _{LOCK}	PLLI2S lock time	VCO freq = 192 MHz	75	-	200	μs	
		VCO freq = 432 MHz	100	-	300		
Jitter ⁽³⁾	Master I2S clock jitter	Cycle to cycle at 12.288 MHz on 48KHz period, N=432, R=5	RMS	-	90	-	-
			peak to peak	-	±280	-	ps
	WS I2S clock jitter	Cycle to cycle at 48 KHz on 1000 samples	Average frequency of 12.288 MHz, N=432, R=5 on 1000 samples	-	90	-	ps
			-	-	400	-	ps

Table 42. PLLI2S (audio PLL) characteristics (continued)

Symbol	Parameter	Conditions	Min	Typ	Max	Unit
I _{DD(PLLI2S)} ⁽⁴⁾	PLLI2S power consumption on V _{DD}	VCO freq = 192 MHz	0.15	-	0.40	mA
		VCO freq = 432 MHz	0.45	-	0.75	
I _{DDA(PLLI2S)} ⁽⁴⁾	PLLI2S power consumption on V _{DDA}	VCO freq = 192 MHz	0.30	-	0.40	mA
		VCO freq = 432 MHz	0.55	-	0.85	

1. Take care of using the appropriate division factor M to have the specified PLL input clock values.
2. Guaranteed by design.
3. Value given with main PLL running.
4. Based on test during characterization.

Table 43. PLLSAI (audio and LCD-TFT PLL) characteristics

Symbol	Parameter	Conditions	Min	Typ	Max	Unit	
f _{PLLSAI_IN}	PLLSAI input clock ⁽¹⁾	-	0.95 ⁽²⁾	1	2.10	MHz	
f _{PLLSAI_OUT}	PLLSAI multiplier output clock	-	-	-	216		
f _{VCO_OUT}	PLLSAI VCO output	-	192	-	432		
t _{LOCK}	PLLSAI lock time	VCO freq = 192 MHz	75	-	200	µs	
		VCO freq = 432 MHz	100	-	300		
Jitter ⁽³⁾	Main SAI clock jitter	Cycle to cycle at 12.288 MHz on 48KHz period, N=432, R=5	RMS	-	90	-	ps
			peak to peak	-	±280	-	
			Average frequency of 12.288 MHz N = 432, R = 5 on 1000 samples	-	90	-	ps
	FS clock jitter	Cycle to cycle at 48 KHz on 1000 samples	-	400	-	ps	
I _{DD(PLLSAI)} ⁽⁴⁾	PLLSAI power consumption on V _{DD}	VCO freq = 192 MHz	0.15	-	0.40	mA	
		VCO freq = 432 MHz	0.45	-	0.75		
I _{DDA(PLLSAI)} ⁽⁴⁾	PLLSAI power consumption on V _{DDA}	VCO freq = 192 MHz	0.30	-	0.40	mA	
		VCO freq = 432 MHz	0.55	-	0.85		

1. Take care of using the appropriate division factor M to have the specified PLL input clock values.
2. Guaranteed by design.
3. Value given with main PLL running.
4. Based on test during characterization.

5.3.12 PLL spread spectrum clock generation (SSCG) characteristics

The spread spectrum clock generation (SSCG) feature allows to reduce electromagnetic interferences (see [Table 54](#)). It is available only on the main PLL.

Table 44. SSCG parameters constraint

Symbol	Parameter	Min	Typ	Max ⁽¹⁾	Unit
f_{Mod}	Modulation frequency	-	-	10	KHz
md	Peak modulation depth	0.25	-	2	%
MODEPER * INCSTEP	-	-	-	$2^{15} - 1$	-

1. Guaranteed by design.

Equation 1

The frequency modulation period (MODEPER) is given by the equation below:

$$MODEPER = \text{round}[f_{PLL_IN} / (4 \times f_{Mod})]$$

f_{PLL_IN} and f_{Mod} must be expressed in Hz.

As an example:

If $f_{PLL_IN} = 1$ MHz, and $f_{MOD} = 1$ kHz, the modulation depth (MODEPER) is given by equation 1:

$$MODEPER = \text{round}[10^6 / (4 \times 10^3)] = 250$$

Equation 2

Equation 2 allows to calculate the increment step (INCSTEP):

$$INCSTEP = \text{round}[(2^{15} - 1) \times md \times PLLN] / (100 \times 5 \times MODEPER)$$

f_{VCO_OUT} must be expressed in MHz.

With a modulation depth (md) = ± 2 % (4 % peak to peak), and PLLN = 240 (in MHz):

$$INCSTEP = \text{round}[(2^{15} - 1) \times 2 \times 240] / (100 \times 5 \times 250) = 126md(\text{quantitized})\%$$

An amplitude quantization error may be generated because the linear modulation profile is obtained by taking the quantized values (rounded to the nearest integer) of MODPER and INCSTEP. As a result, the achieved modulation depth is quantized. The percentage quantized modulation depth is given by the following formula:

$$md_{\text{quantitized}}\% = (MODEPER \times INCSTEP \times 100 \times 5) / ((2^{15} - 1) \times PLLN)$$

As a result:

$$md_{\text{quantitized}}\% = (250 \times 126 \times 100 \times 5) / ((2^{15} - 1) \times 240) = 2.002\%(\text{peak})$$

Figure 33 and Figure 34 show the main PLL output clock waveforms in center spread and down spread modes, where:

- F0 is f_{PLL_OUT} nominal.
- T_{mode} is the modulation period.
- md is the modulation depth.

Figure 33. PLL output clock waveforms in center spread mode

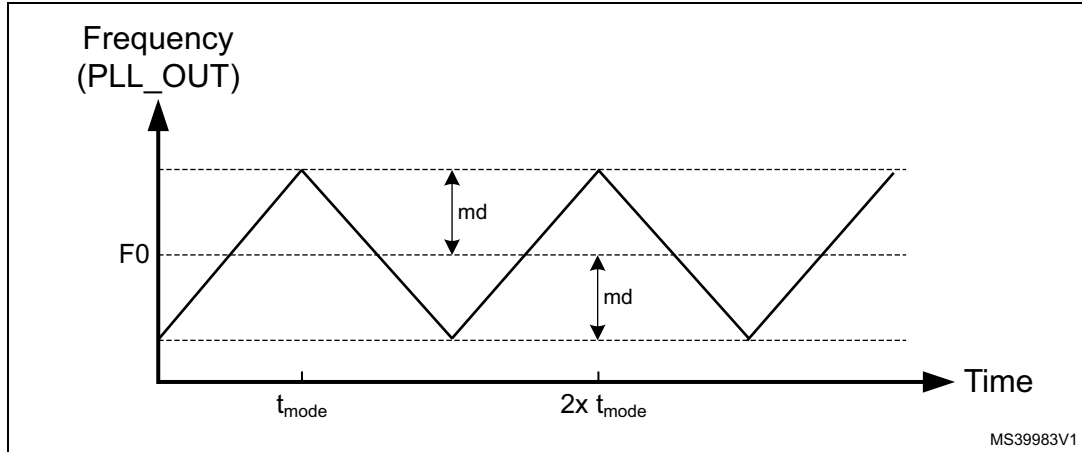
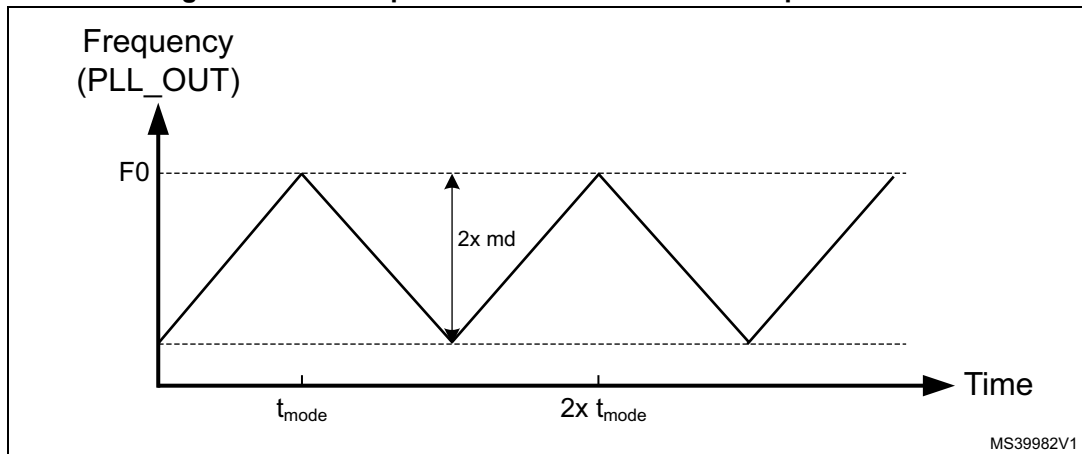

Figure 34. PLL output clock waveforms in down spread mode



5.3.13 MIPI D-PHY characteristics

The parameters given in Table 45 and Table 46 are derived from tests performed under temperature and V_{DD} supply voltage conditions summarized in Table 17.

Table 45. MIPI D-PHY characteristics⁽¹⁾

Symbol	Parameter	Conditions	Min	Typ	Max	Unit
Hi-Speed Input/Output Characteristics						
U_{INST}	UI instantaneous	-	2	-	12.5	ns

Table 45. MIPI D-PHY characteristics⁽¹⁾ (continued)

Symbol	Parameter	Conditions	Min	Typ	Max	Unit
V_{CMTX}	HS transmit common mode voltage	-	150	200	250	mV
$ \Delta V_{CMTX} $	V_{CMTX} mismatch when output is Differential-1 or Differential-0	-	-	-	5	
$ V_{OD} $	HS transmit differential voltage	-	140	200	270	
$ \Delta V_{OD} $	V_{OD} mismatch when output is Differential-1 or Differential-0	-	-	-	14	
V_{OHHS}	HS output high voltage	-	-	-	360	
Z_{OS}	Single ended output impedance	-	40	50	62.5	Ω
ΔZ_{OS}	Single ended output impedance mismatch	-	-	-	10	%
t_{HSr} & t_{HSf}	20%-80% rise and fall time	-	100	-	$0.35 \cdot UI$	ps
LP Receiver Input Characteristics						
V_{IL}	Logic 0 input voltage (not in ULP State)	-	-	-	550	mV
$V_{IL-ULPS}$	Logic 0 input voltage in ULP State	-	-	-	300	
V_{IH}	Input high level voltage	-	880	-	-	
V_{hys}	Voltage hysteresis	-	25	-	-	
LP Emitter Output Characteristics						
V_{IL}	Output low level voltage	-	1.1	1.2	1.2	V
$V_{IL-ULPS}$	Output high level voltage	-	-50	-	50	mV
V_{IH}	Output impedance of LP transmitter	-	110	-	-	Ω
V_{hys}	15%-85% rise and fall time	-	-	-	25	ns
LP Contention Detector Characteristics						
V_{ILCD}	Logic 0 contention threshold	-	-	-	200	mV
V_{IHCD}	Logic 0 contention threshold	-	450	-	-	

1. Guaranteed based on test during characterization.

Table 46. MIPI D-PHY AC characteristics LP mode and HS/LP transitions⁽¹⁾

Symbol	Parameter	Conditions	Min	Typ	Max	Unit
T_{LPX}	Transmitted length of any Low-Power state period	-	50	-	-	ns
$T_{CLK-PREPARE}$	Time that the transmitter drives the Clock Lane LP-00 Line state immediately before the HS-0 Line state starting the HS transmission.	-	38	-	95	
$T_{CLK-PREPARE} + T_{CLK-ZERO}$	Time that the transmitter drives the HS-0 state prior to starting the clock.	-	300	-	-	
$T_{CLK-PRE}$	Time that the HS clock shall be driven by the transmitter prior to any associated Data Lane beginning the transition from LP to HS mode.	-	8	-	-	UI
$T_{CLK-POST}$	Time that the transmitter continues to send HS clock after the last associated Data Lane has transitioned to LP Mode.	-	$62+52*UI$	-	-	ns
$T_{CLK-TRAIL}$	Time that the transmitter drives the HS-0 state after the last payload clock bit of an HS transmission burst.	-	60	-	-	
$T_{HS-PREPARE}$	Time that the transmitter drives the Data Lane LP-00 Line state immediately before the HS-0 Line state starting the HS transmission.	-	$40+4*UI$	-	$85+6*UI$	
$T_{HS-PREPARE} + T_{HS-ZERO}$	$T_{HS-PREPARE} +$ Time that the transmitter drives the HS-0 state prior to transmitting the Sync sequence.	-	$145+10*UI$	-	-	
$T_{HS-TRAIL}$	Time that the transmitter drives the flipped differential state after last payload data bit of a HS transmission burst.	-	Max ($n*8*UI$, $60+n*4*UI$)	-	-	
$T_{HS-EXIT}$	Time that the transmitter drives LP-11 following a HS burst.	-	100	-	-	
T_{REOT}	30%-85% rise time and fall time	-	-	-	35	
T_{EOT}	Transmitted time interval from the start of $T_{HS-TRAIL}$ OR $T_{CLK-TRAIL}$ to the start of the LP-11 state following a HS burst.	-	-	-	$105+n*12UI$	

1. Guaranteed based on test during characterization.

Figure 35. MIPI D-PHY HS/LP clock lane transition timing diagram

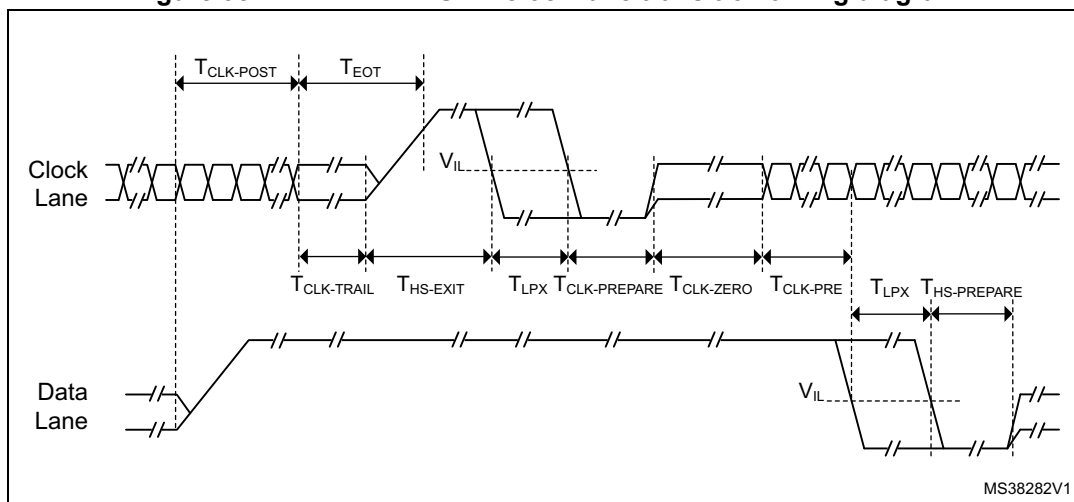

MS38282V1

Figure 36. MIPI D-PHY HS/LP data lane transition timing diagram

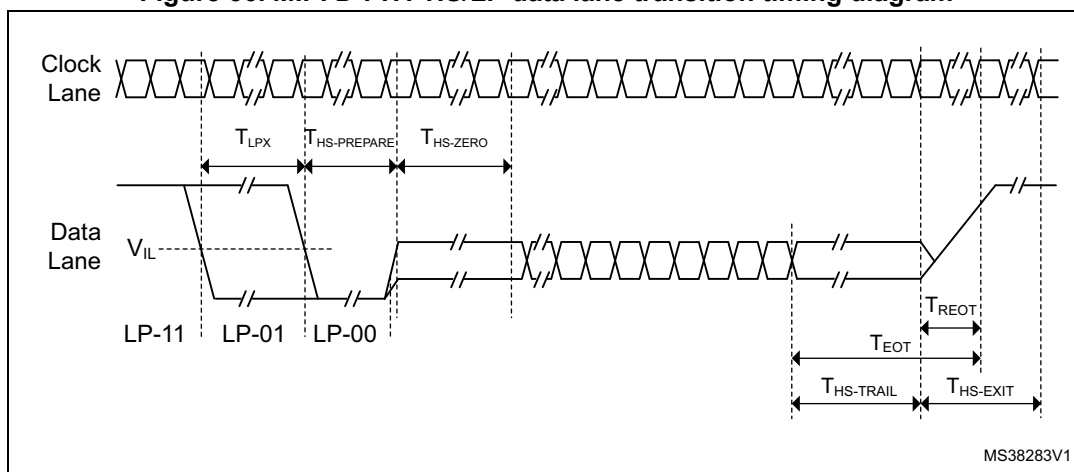

MS38283V1

5.3.14 MIPI D-PHY PLL characteristics

The parameters given in [Table 47](#) are derived from tests performed under temperature and V_{DD} supply voltage conditions summarized in [Table 17](#).

Table 47. DSI-PLL characteristics⁽¹⁾

Symbol	Parameter	Conditions	Min	Typ	Max	Unit
f_{PLL_IN}	PLL input clock	-	4	-	100	MHz
f_{PLL_INFIN}	PFD input clock	-	4	-	25	
f_{PLL_OUT}	PLL multiplier output clock	-	31.25	-	500	
f_{VCO_OUT}	PLL VCO output	-	500	-	1000	
t_{LOCK}	PLL lock time	-	-	-	200	μs

Table 47. DSI-PLL characteristics⁽¹⁾ (continued)

Symbol	Parameter	Conditions	Min	Typ	Max	Unit
I _{DD(PLL)}	PLL power consumption on V _{DD12}	f _{VCO_OUT} = 500 MHz	-	0.55	0.70	mA
		f _{VCO_OUT} = 600 MHz	-	0.65	0.80	
		f _{VCO_OUT} = 1000 MHz	-	0.95	1.20	

1. Based on test during characterization.

5.3.15 MIPI D-PHY regulator characteristics

The parameters given in [Table 48](#) are derived from tests performed under temperature and V_{DD} supply voltage conditions summarized in [Table 17](#).

Table 48. DSI regulator characteristics⁽¹⁾

Symbol	Parameter	Conditions	Min	Typ	Max	Unit
V _{DD12DSI}	1.2 V internal voltage on V _{DD12DSI}	-	1.15	1.20	1.30	V
C _{EXT}	External capacitor on V _{CAPDSI}	-	1.1	2.2	3.3	μF
ESR	External Serial Resistor	-	0	25	600	mΩ
I _{DDDSIREG}	Regulator power consumption	-	100	120	125	μA
I _{DDDSI}	DSI system (regulator, PLL and D-PHY) current consumption on V _{DDDSI}	Ultra Low Power Mode (Reg. ON + PLL OFF)	-	290	600	μA
		Stop State (Reg. ON + PLL OFF)	-	290	600	
I _{DDDSILP}	DSI system current consumption on V _{DDDSI} in LP mode communication ⁽²⁾	10 MHz escape clock (Reg. ON + PLL OFF)	-	4.3	5.0	mA
		20 MHz escape clock (Reg. ON + PLL OFF)	-	4.3	5.0	
I _{DDDSIHS}	DSI system (regulator, PLL and D-PHY) current consumption on V _{DDDSI} in HS mode communication ⁽³⁾	300 Mbps - 1 data lane (Reg. ON + PLL ON)	-	8.0	8.8	mA
		300 Mbps - 2data lane (Reg. ON + PLL ON)	-	11.4	12.5	
		500 Mbps - 1 data lane (Reg. ON + PLL ON)	-	13.5	14.7	
		500 Mbps - 2data lane (Reg. ON + PLL ON)	-	18.0	19.6	
	DSI system (regulator, PLL and D-PHY) current consumption on V _{DDDSI} in HS mode with CLK like payload	-	21.4	23.3		
t _{WAKEUP}	Startup delay	C _{EXT} = 2.2 μF	-	110	-	μs
		C _{EXT} = 3.3 μF	-	-	160	
I _{INRUSH}	Inrush current on V _{DDDSI}	External capacitor load at start	-	60	200	mA

1. Based on test during characterization.

2. Values based on an average traffic in LP Command Mode.

3. Values based on an average traffic (3/4 HS traffic & 1/4 LP) in Video Mode.

5.3.16 Memory characteristics

Flash memory

The characteristics are given at $T_A = -40$ to 105 °C unless otherwise specified.

The devices are shipped to customers with the Flash memory erased.

Table 49. Flash memory characteristics

Symbol	Parameter	Conditions	Min	Typ	Max	Unit
I_{DD}	Supply current	Write / Erase 8-bit mode, $V_{DD} = 1.7$ V	-	5	-	mA
		Write / Erase 16-bit mode, $V_{DD} = 2.1$ V	-	8	-	
		Write / Erase 32-bit mode, $V_{DD} = 3.3$ V	-	12	-	

Table 50. Flash memory programming

Symbol	Parameter	Conditions	Min ⁽¹⁾	Typ	Max ⁽¹⁾	Unit
t_{prog}	Word programming time	Program/erase parallelism (PSIZE) = x 8/16/32	-	16	100 ⁽²⁾	μ s
$t_{ERASE16KB}$	Sector (16 KB) erase time	Program/erase parallelism (PSIZE) = x 8	-	400	800	ms
		Program/erase parallelism (PSIZE) = x 16	-	300	600	
		Program/erase parallelism (PSIZE) = x 32	-	250	500	
$t_{ERASE64KB}$	Sector (64 KB) erase time	Program/erase parallelism (PSIZE) = x 8	-	1200	2400	ms
		Program/erase parallelism (PSIZE) = x 16	-	700	1400	
		Program/erase parallelism (PSIZE) = x 32	-	550	1100	
$t_{ERASE128KB}$	Sector (128 KB) erase time	Program/erase parallelism (PSIZE) = x 8	-	2	4	s
		Program/erase parallelism (PSIZE) = x 16	-	1.3	2.6	
		Program/erase parallelism (PSIZE) = x 32	-	1	2	

Table 50. Flash memory programming (continued)

Symbol	Parameter	Conditions	Min ⁽¹⁾	Typ	Max ⁽¹⁾	Unit
t _{ME}	Mass erase time	Program/erase parallelism (PSIZE) = x 8	-	16	32	s
		Program/erase parallelism (PSIZE) = x 16	-	11	22	
		Program/erase parallelism (PSIZE) = x 32	-	8	16	
t _{BE}	Bank erase time	Program/erase parallelism (PSIZE) = x 8	-	16	32	
		Program/erase parallelism (PSIZE) = x 16	-	11	22	
		Program/erase parallelism (PSIZE) = x 32	-	8	16	
V _{prog}	Programming voltage	32-bit program operation	2.7	-	3.6	V
		16-bit program operation	2.1	-	3.6	
		8-bit program operation	1.7	-	3.6	

1. Based on test during characterization.
2. The maximum programming time is measured after 100K erase operations.

Table 51. Flash memory programming with V_{PP}

Symbol	Parameter	Conditions	Min ⁽¹⁾	Typ	Max ⁽¹⁾	Unit
t _{prog}	Double word programming	T _A = 0 to +40 °C V _{DD} = 3.3 V V _{PP} = 8.5 V	-	16	100 ⁽²⁾	µs
t _{ERASE16KB}	Sector (16 KB) erase time		-	230	-	ms
t _{ERASE64KB}	Sector (64 KB) erase time		-	490	-	
t _{ERASE128KB}	Sector (128 KB) erase time		-	875	-	
t _{ME}	Mass erase time	-	-	6.9	-	s
t _{BE}	Bank erase time	-	-	6.9	-	s
V _{prog}	Programming voltage	-	2.7	-	3.6	V
V _{PP}	V _{PP} voltage range	-	7	-	9	
I _{PP}	Minimum current sunk on the V _{PP} pin	-	10	-	-	mA
t _{VPP} ⁽³⁾	Cumulative time during which V _{PP} is applied	-	-	-	1	hour

1. Guaranteed by design.
2. The maximum programming time is measured after 100K erase operations.
3. V_{PP} should only be connected during programming/erasing.

Table 52. Flash memory endurance and data retention

Symbol	Parameter	Conditions	Value	Unit
			Min ⁽¹⁾	
N _{END}	Endurance	T _A = -40 to +85 °C (6 suffix versions) T _A = -40 to +105 °C (7 suffix versions)	10	kcycles
t _{RET}	Data retention	1 kcycle ⁽²⁾ at T _A = 85 °C	30	Years
		1 kcycle ⁽²⁾ at T _A = 105 °C	10	
		10 kcycles ⁽²⁾ at T _A = 55 °C	20	

1. Based on test during characterization.
2. Cycling performed over the whole temperature range.

5.3.17 EMC characteristics

Susceptibility tests are performed on a sample basis during device characterization.

Functional EMS (electromagnetic susceptibility)

While a simple application is executed on the device (toggling 2 LEDs through I/O ports), the device is stressed by two electromagnetic events until a failure occurs. The failure is indicated by the LEDs:

- **Electrostatic discharge (ESD)** (positive and negative) is applied to all device pins until a functional disturbance occurs. This test is compliant with the IEC 61000-4-2 standard.
- **FTB**: A burst of fast transient voltage (positive and negative) is applied to V_{DD} and V_{SS} through a 100 pF capacitor, until a functional disturbance occurs. This test is compliant with the IEC 61000-4-4 standard.

A device reset allows normal operations to be resumed.

The test results are given in [Table 53](#). They are based on the EMS levels and classes defined in application note AN1709.

Table 53. EMS characteristics

Symbol	Parameter	Conditions	Level/Class
V _{FESD}	Voltage limits to be applied on any I/O pin to induce a functional disturbance	V _{DD} = 3.3 V, TFBGA216, T _A = +25 °C, f _{HCLK} = 168 MHz, conforming to IEC 61000-4-2	2B
V _{EFTB}	Fast transient voltage burst limits to be applied through 100 pF on V _{DD} and V _{SS} pins to induce a functional disturbance	V _{DD} = 3.3 V, TFBGA216, T _A = +25 °C, f _{HCLK} = 168 MHz, conforming to IEC 61000-4-2	4A

Designing hardened software to avoid noise problems

EMC characterization and optimization are performed at component level with a typical application environment and simplified MCU software. It should be noted that good EMC performance is highly dependent on the user application and the software in particular.

Therefore it is recommended that the user applies EMC software optimization and prequalification tests in relation with the EMC level requested for his application.

Software recommendations

The software flowchart must include the management of runaway conditions such as:

- Corrupted program counter
- Unexpected reset
- Critical Data corruption (control registers...)

Prequalification trials

Most of the common failures (unexpected reset and program counter corruption) can be reproduced by manually forcing a low state on the NRST pin or the Oscillator pins for 1 second.

To complete these trials, ESD stress can be applied directly on the device, over the range of specification values. When unexpected behavior is detected, the software can be hardened to prevent unrecoverable errors occurring (see application note AN1015).

Electromagnetic Interference (EMI)

The electromagnetic field emitted by the device are monitored while a simple application, executing EEMBC[?] code, is running. This emission test is compliant with SAE IEC61967-2 standard which specifies the test board and the pin loading.

Table 54. EMI characteristics

Symbol	Parameter	Conditions	Monitored frequency band	Max vs. [f _{HSE} /f _{CPU}]		Unit
				8/168 MHz	8/180 MHz	
S _{EMI}	Peak level	V _{DD} = 3.3 V, T _A = 25 °C, TFBGA216 package, conforming to SAE J1752/3 EEMBC, ART ON, all peripheral clocks enabled, clock dithering disabled.	0.1 to 30 MHz	2	2	dBμV
			30 to 130 MHz	4	1	
			130 MHz to 1GHz	10	10	
			SAE EMI Level	3	3	-
	Peak level	V _{DD} = 3.3 V, T _A = 25 °C, TFBGA216 package, conforming to SAE J1752/3 EEMBC, ART ON, all peripheral clocks enabled, clock dithering enabled	0.1 to 30 MHz	5	-10	dBμV
			30 to 130 MHz	3	-15	
			130 MHz to 1GHz	8	0	
			SAE EMI level	2	2	-

5.3.18 Absolute maximum ratings (electrical sensitivity)

Based on three different tests (ESD, LU) using specific measurement methods, the device is stressed in order to determine its performance in terms of electrical sensitivity.

Electrostatic discharge (ESD)

Electrostatic discharges (a positive then a negative pulse separated by 1 second) are applied to the pins of each sample according to each pin combination. The sample size depends on the number of supply pins in the device (3 parts × (n+1) supply pins). This test conforms to the ANSI/ESDA/JEDEC JS-001 and ANSI/ESD S5.3.1 standards.

Table 55. ESD absolute maximum ratings

Symbol	Ratings	Conditions	Class	Maximum value ⁽¹⁾	Unit
V _{ESD(HBM)}	Electrostatic discharge voltage (human body model)	T _A = +25 °C conforming to ANSI/ESDA/JEDEC JS-001	2	2000	V
V _{ESD(CDM)}	Electrostatic discharge voltage (charge device model)	T _A = +25 °C conforming to ANSI/ESD S5.3.1, LQFP176, LQFP208, UFBGA169, UFBGA176, TFBGA216 and WLCSP148 packages	C3	250	

1. Guaranteed based on test during characterization.

Static latchup

Two complementary static tests are required on six parts to assess the latchup performance:

- A supply overvoltage is applied to each power supply pin
- A current injection is applied to each input, output and configurable I/O pin

These tests are compliant with EIA/JESD 78A IC latchup standard.

Table 56. Electrical sensitivities⁽¹⁾

Symbol	Parameter	Conditions	Class
LU	Static latch-up class	T _A = +105 °C conforming to JESD78A	II level A

1. MSV on PA4 and PA5 is 5 V, versus 5.4 V on all IOs.

5.3.19 I/O current injection characteristics

As a general rule, current injection to the I/O pins, due to external voltage below V_{SS} or above V_{DD} (for standard, 3 V-capable I/O pins) should be avoided during normal product operation. However, in order to give an indication of the robustness of the microcontroller in cases when abnormal injection accidentally happens, susceptibility tests are performed on a sample basis during device characterization.

Functional susceptibility to I/O current injection

While a simple application is executed on the device, the device is stressed by injecting current into the I/O pins programmed in floating input mode. While current is injected into the I/O pin, one at a time, the device is checked for functional failures.

The failure is indicated by an out of range parameter: ADC error above a certain limit (>5 LSB TUE), out of conventional limits of induced leakage current on adjacent pins (out of – 5 µA/+0 µA range), or other functional failure (for example reset, oscillator frequency deviation).

Negative induced leakage current is caused by negative injection and positive induced leakage current by positive injection.

The test results are given in [Table 57](#).

Table 57. I/O current injection susceptibility⁽¹⁾

Symbol	Description	Functional susceptibility		Unit
		Negative injection	Positive injection	
I _{INJ}	Injected current on BOOT0 and NRST pins	- 0	NA	mA
	Injected current on DSIHOST_D0P, DSIHOST_D0N, DSIHOST_D1P, DSIHOST_D0N, DSIHOST_CKP, DSIHOST_CKN pins	- 0	0	
	Injected current on PA0 and PC0 pins	- 0	NA	
	Injected current on any other FT pin	- 5	NA	
	Injected current on any other pin	- 5	+ 5	

1. NA = not applicable.

Note: It is recommended to add a Schottky diode (pin to ground) to analog pins which may potentially inject negative currents.

5.3.20 I/O port characteristics

General input/output characteristics

Unless otherwise specified, the parameters given in [Table 58](#) are derived from tests performed under the conditions summarized in [Table 17](#). All I/Os are CMOS and TTL compliant.

Table 58. I/O static characteristics

Symbol	Parameter	Conditions	Min	Typ	Max	Unit
V _{IL}	FT, TTA and NRST I/O input low level voltage	1.7 V ≤ V _{DD} ≤ 3.6 V	-	-	0.35V _{DD} - 0.04 ⁽¹⁾	V
			-	-	0.3V _{DD} ⁽²⁾	
	BOOT0 I/O input low level voltage	1.75 V ≤ V _{DD} ≤ 3.6 V, -40 °C ≤ T _A ≤ 105 °C	-	-	0.1V _{DD} + 0.1 ⁽¹⁾	
1.7 V ≤ V _{DD} ≤ 3.6 V, 0 °C ≤ T _A ≤ 105 °C			-	-		
V _{IH}	FT, TTA and NRST I/O input high level voltage ⁽⁵⁾	1.7 V ≤ V _{DD} ≤ 3.6 V	0.45V _{DD} + 0.3 ⁽¹⁾	-	-	
			0.7V _{DD} ⁽²⁾	-	-	
	BOOT0 I/O input high level voltage	1.75 V ≤ V _{DD} ≤ 3.6 V, -40 °C ≤ T _A ≤ 105 °C	0.17V _{DD} + 0.7 ⁽¹⁾	-	-	-
				1.7 V ≤ V _{DD} ≤ 3.6 V, 0 °C ≤ T _A ≤ 105 °C	-	-



Table 58. I/O static characteristics (continued)

Symbol	Parameter		Conditions	Min	Typ	Max	Unit
V _{HYS}	FT, TTA and NRST I/O input hysteresis		1.7 V ≤ V _{DD} ≤ 3.6 V	10%V _{DD} ⁽³⁾	-	-	V
	BOOT0 I/O input hysteresis		1.75 V ≤ V _{DD} ≤ 3.6 V, -40 °C ≤ T _A ≤ 105 °C	0.1	-	-	
		1.7 V ≤ V _{DD} ≤ 3.6 V, 0 °C ≤ T _A ≤ 105 °C					
I _{lkg}	I/O input leakage current ⁽⁴⁾		V _{SS} ≤ V _{IN} ≤ V _{DD}	-	-	±1	μA
	I/O FT input leakage current ⁽⁵⁾		V _{IN} = 5 V	-	-	3	
R _{PU}	Weak pull-up equivalent resistor ⁽⁶⁾	All pins except for PA10/PB12 (OTG_FS_ID, OTG_HS_ID)	V _{IN} = V _{SS}	30	40	50	kΩ
		PA10/PB12 (OTG_FS_ID, OTG_HS_ID)		7	10	14	
R _{PD}	Weak pull-down equivalent resistor ⁽⁷⁾	All pins except for PA10/PB12 (OTG_FS_ID, OTG_HS_ID)	V _{IN} = V _{DD}	30	40	50	
		PA10/PB12 (OTG_FS_ID, OTG_HS_ID)		7	10	14	
C _{IO} ⁽⁸⁾	I/O pin capacitance		-	-	5	-	pF

1. Guaranteed by design.
2. Tested in production.
3. With a minimum of 200 mV.
4. Leakage could be higher than the maximum value, if negative current is injected on adjacent pins, Refer to [Table 57](#)
5. To sustain a voltage higher than VDD +0.3 V, the internal pull-up/pull-down resistors must be disabled. Leakage could be higher than the maximum value, if negative current is injected on adjacent pins. Refer to [Table 57](#)
6. Pull-up resistors are designed with a true resistance in series with a switchable PMOS. This PMOS contribution to the series resistance is minimum (~10% order).
7. Pull-down resistors are designed with a true resistance in series with a switchable NMOS. This NMOS contribution to the series resistance is minimum (~10% order).
8. Hysteresis voltage between Schmitt trigger switching levels. Based on test during characterization.

All I/Os are CMOS and TTL compliant (no software configuration required). Their characteristics cover more than the strict CMOS-technology or TTL parameters. The coverage of these requirements for FT I/Os is shown in [Figure 37](#).

Figure 37. FT I/O input characteristics

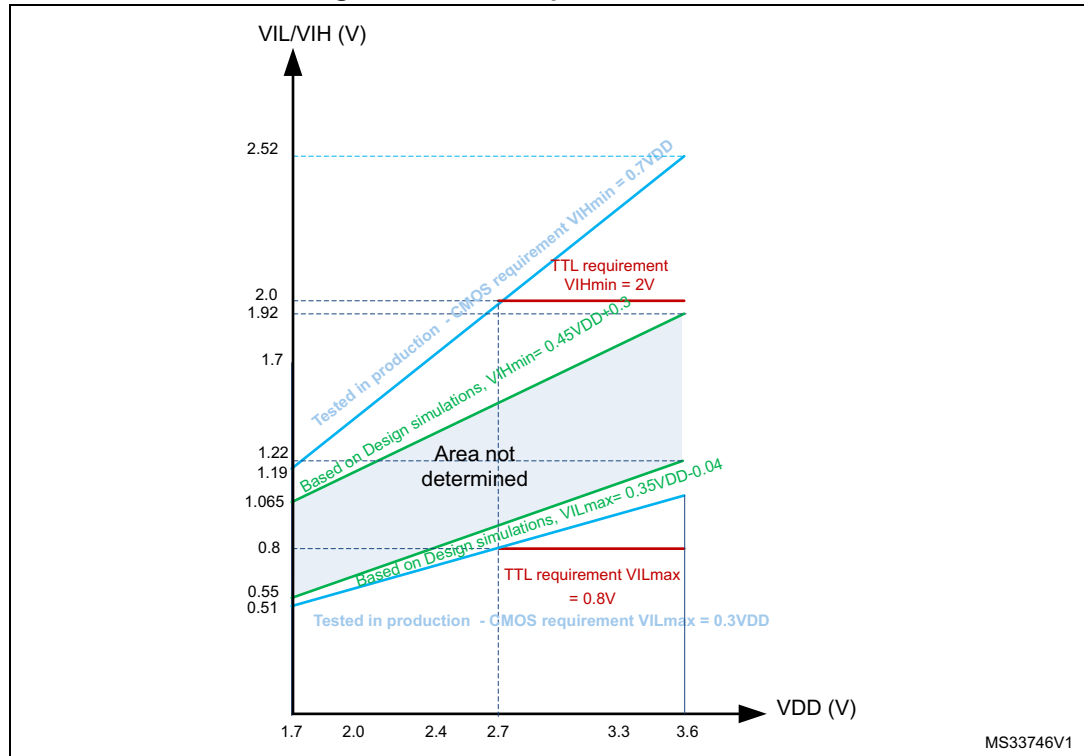

Output driving current

The GPIOs (general purpose input/outputs) can sink or source up to ± 8 mA, and sink or source up to ± 20 mA (with a relaxed V_{OL}/V_{OH}) except PC13, PC14, PC15 and PI8 which can sink or source up to ± 3 mA. When using the PC13 to PC15 and PI8 GPIOs in output mode, the speed should not exceed 2 MHz with a maximum load of 30 pF.

In the user application, the number of I/O pins which can drive current must be limited to respect the absolute maximum rating specified in [Section 5.2](#). In particular:

- The sum of the currents sourced by all the I/Os on V_{DD} , plus the maximum Run consumption of the MCU sourced on V_{DD} , cannot exceed the absolute maximum rating ΣI_{VDD} (see [Table 15](#)).
- The sum of the currents sunk by all the I/Os on V_{SS} plus the maximum Run consumption of the MCU sunk on V_{SS} cannot exceed the absolute maximum rating ΣI_{VSS} (see [Table 15](#)).

Output voltage levels

Unless otherwise specified, the parameters given in [Table 59](#) are derived from tests performed under ambient temperature and V_{DD} supply voltage conditions summarized in [Table 17](#). All I/Os are CMOS and TTL compliant.

Table 59. Output voltage characteristics

Symbol	Parameter	Conditions	Min	Max	Unit
$V_{OL}^{(1)}$	Output low level voltage for an I/O pin	CMOS port ⁽²⁾ $I_{IO} = +8 \text{ mA}$ $2.7 \text{ V} \leq V_{DD} \leq 3.6 \text{ V}$	-	0.4	V
$V_{OH}^{(3)}$	Output high level voltage for an I/O pin		$V_{DD} - 0.4$	-	
$V_{OL}^{(1)}$	Output low level voltage for an I/O pin	TTL port ⁽²⁾ $I_{IO} = +8 \text{ mA}$ $2.7 \text{ V} \leq V_{DD} \leq 3.6 \text{ V}$	-	0.4	
$V_{OH}^{(3)}$	Output high level voltage for an I/O pin		2.4	-	
$V_{OL}^{(1)}$	Output low level voltage for an I/O pin	$I_{IO} = +20 \text{ mA}$ $2.7 \text{ V} \leq V_{DD} \leq 3.6 \text{ V}$	-	1.3 ⁽⁴⁾	
$V_{OH}^{(3)}$	Output high level voltage for an I/O pin		$V_{DD} - 1.3^{(4)}$	-	
$V_{OL}^{(1)}$	Output low level voltage for an I/O pin	$I_{IO} = +6 \text{ mA}$ $1.8 \text{ V} \leq V_{DD} \leq 3.6 \text{ V}$	-	0.4 ⁽⁴⁾	
$V_{OH}^{(3)}$	Output high level voltage for an I/O pin		$V_{DD} - 0.4^{(4)}$	-	
$V_{OL}^{(1)}$	Output low level voltage for an I/O pin	$I_{IO} = +4 \text{ mA}$ $1.7 \text{ V} \leq V_{DD} \leq 3.6 \text{ V}$	-	0.4 ⁽⁵⁾	
$V_{OH}^{(3)}$	Output high level voltage for an I/O pin		$V_{DD} - 0.4^{(5)}$	-	

1. The I_{IO} current sunk by the device must always respect the absolute maximum rating specified in [Table 15](#) and the sum of I_{IO} (I/O ports and control pins) must not exceed I_{VSS} .
2. TTL and CMOS outputs are compatible with JEDEC standards JESD36 and JESD52.
3. The I_{IO} current sourced by the device must always respect the absolute maximum rating specified in [Table 15](#) and the sum of I_{IO} (I/O ports and control pins) must not exceed I_{VDD} .
4. Based on characterization data.
5. Guaranteed by design.

Input/output AC characteristics

The definition and values of input/output AC characteristics are given in [Figure 38](#) and [Table 60](#), respectively.

Unless otherwise specified, the parameters given in [Table 60](#) are derived from tests performed under the ambient temperature and V_{DD} supply voltage conditions summarized in [Table 17](#).

Table 60. I/O AC characteristics⁽¹⁾⁽²⁾

OSPEEDRy [1:0] bit value ⁽¹⁾	Symbol	Parameter	Conditions	Min	Typ	Max	Unit	
00	f _{max(IO)out}	Maximum frequency ⁽³⁾	C _L = 50 pF, V _{DD} ≥ 2.7 V	-	-	4	MHz	
			C _L = 50 pF, V _{DD} ≥ 1.7 V	-	-	2		
			C _L = 10 pF, V _{DD} ≥ 2.7 V	-	-	8		
			C _L = 10 pF, V _{DD} ≥ 1.8 V	-	-	4		
			C _L = 10 pF, V _{DD} ≥ 1.7 V	-	-	3		
	t _{f(IO)out} / t _{r(IO)out}	Output high to low level fall time and output low to high level rise time	C _L = 50 pF, V _{DD} = 1.7 V to 3.6 V	-	-	100	ns	
01	f _{max(IO)out}	Maximum frequency ⁽³⁾	C _L = 50 pF, V _{DD} ≥ 2.7 V	-	-	25	MHz	
			C _L = 50 pF, V _{DD} ≥ 1.8 V	-	-	12.5		
			C _L = 50 pF, V _{DD} ≥ 1.7 V	-	-	10		
			C _L = 10 pF, V _{DD} ≥ 2.7 V	-	-	50		
			C _L = 10 pF, V _{DD} ≥ 1.8 V	-	-	20		
			C _L = 10 pF, V _{DD} ≥ 1.7 V	-	-	12.5		
	t _{f(IO)out} / t _{r(IO)out}	Output high to low level fall time and output low to high level rise time	C _L = 50 pF, V _{DD} ≥ 2.7 V	-	-	10	ns	
C _L = 10 pF, V _{DD} ≥ 2.7 V			-	-	6			
C _L = 50 pF, V _{DD} ≥ 1.7 V			-	-	20			
C _L = 10 pF, V _{DD} ≥ 1.7 V			-	-	10			
10	f _{max(IO)out}	Maximum frequency ⁽³⁾	C _L = 40 pF, V _{DD} ≥ 2.7 V	-	-	50 ⁽⁴⁾	MHz	
			C _L = 10 pF, V _{DD} ≥ 2.7 V	-	-	100 ⁽⁴⁾		
			C _L = 40 pF, V _{DD} ≥ 1.7 V	-	-	25		
			C _L = 10 pF, V _{DD} ≥ 1.8 V	-	-	50		
			C _L = 10 pF, V _{DD} ≥ 1.7 V	-	-	42.5		
		t _{f(IO)out} / t _{r(IO)out}	Output high to low level fall time and output low to high level rise time	C _L = 40 pF, V _{DD} ≥ 2.7 V	-	-	6	ns
	C _L = 10 pF, V _{DD} ≥ 2.7 V			-	-	4		
	C _L = 40 pF, V _{DD} ≥ 1.7 V			-	-	10		
C _L = 10 pF, V _{DD} ≥ 1.7 V	-			-	6			

Table 60. I/O AC characteristics⁽¹⁾⁽²⁾ (continued)

OSPEEDRy [1:0] bit value ⁽¹⁾	Symbol	Parameter	Conditions	Min	Typ	Max	Unit
11	$f_{\max(\text{IO})\text{out}}$	Maximum frequency ⁽³⁾	$C_L = 30 \text{ pF}, V_{DD} \geq 2.7 \text{ V}$	-	-	100 ⁽⁴⁾	MHz
			$C_L = 30 \text{ pF}, V_{DD} \geq 1.8 \text{ V}$	-	-	50	
			$C_L = 30 \text{ pF}, V_{DD} \geq 1.7 \text{ V}$	-	-	42.5	
			$C_L = 10 \text{ pF}, V_{DD} \geq 2.7 \text{ V}$	-	-	180 ⁽⁴⁾	
			$C_L = 10 \text{ pF}, V_{DD} \geq 1.8 \text{ V}$	-	-	100	
			$C_L = 10 \text{ pF}, V_{DD} \geq 1.7 \text{ V}$	-	-	72.5	
	$t_{f(\text{IO})\text{out}}/ t_{r(\text{IO})\text{out}}$	Output high to low level fall time and output low to high level rise time	$C_L = 30 \text{ pF}, V_{DD} \geq 2.7 \text{ V}$	-	-	4	ns
			$C_L = 30 \text{ pF}, V_{DD} \geq 1.8 \text{ V}$	-	-	6	
			$C_L = 30 \text{ pF}, V_{DD} \geq 1.7 \text{ V}$	-	-	7	
			$C_L = 10 \text{ pF}, V_{DD} \geq 2.7 \text{ V}$	-	-	2.5	
			$C_L = 10 \text{ pF}, V_{DD} \geq 1.8 \text{ V}$	-	-	3.5	
			$C_L = 10 \text{ pF}, V_{DD} \geq 1.7 \text{ V}$	-	-	4	
-	$t_{\text{EXTI}pw}$	Pulse width of external signals detected by the EXTI controller	-	10	-	-	ns

1. Guaranteed by design.
2. The I/O speed is configured using the OSPEEDRy[1:0] bits. Refer to the STM32F4xx reference manual for a description of the GPIOx_SPEEDR GPIO port output speed register.
3. The maximum frequency is defined in [Figure 38](#).
4. For maximum frequencies above 50 MHz and $V_{DD} > 2.4 \text{ V}$, the compensation cell should be used.

Figure 38. I/O AC characteristics definition

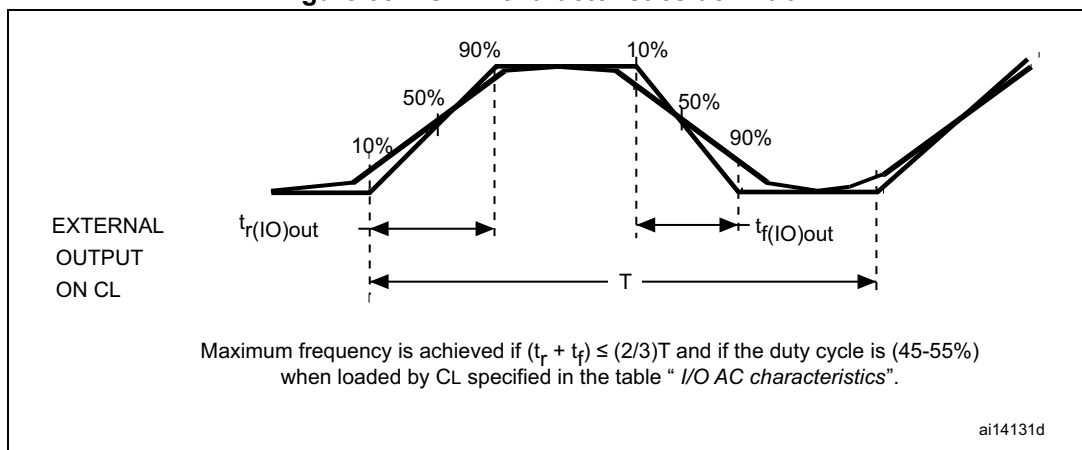

5.3.21 NRST pin characteristics

The NRST pin input driver uses CMOS technology. It is connected to a permanent pull-up resistor, R_{PU} (see [Table 58](#)).

Unless otherwise specified, the parameters given in [Table 61](#) are derived from tests performed under the ambient temperature and V_{DD} supply voltage conditions summarized in [Table 17](#).

Table 61. NRST pin characteristics

Symbol	Parameter	Conditions	Min	Typ	Max	Unit
R_{PU}	Weak pull-up equivalent resistor ⁽¹⁾	$V_{IN} = V_{SS}$	30	40	50	k Ω
$V_{F(NRST)}$ ⁽²⁾	NRST Input filtered pulse	-	-	-	100	ns
$V_{NF(NRST)}$ ⁽²⁾	NRST Input not filtered pulse	$V_{DD} > 2.7 V$	300	-	-	
T_{NRST_OUT}	Generated reset pulse duration	Internal Reset source	20	-	-	μs

1. The pull-up is designed with a true resistance in series with a switchable PMOS. This PMOS contribution to the series resistance must be minimum (~10% order).
2. Guaranteed by design.

Figure 39. Recommended NRST pin protection

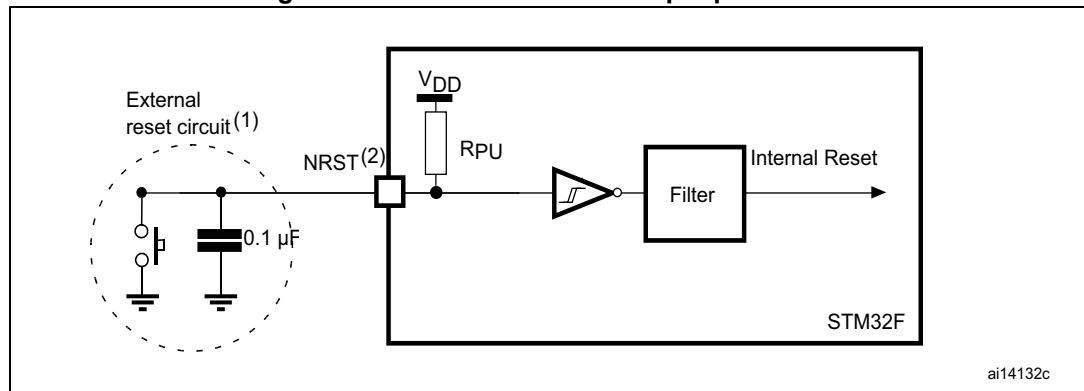

1. The reset network protects the device against parasitic resets.
2. The user must ensure that the level on the NRST pin can go below the $V_{IL(NRST)}$ max level specified in [Table 61](#). Otherwise the reset is not taken into account by the device.

5.3.22 TIM timer characteristics

The parameters given in [Table 62](#) are guaranteed by design. Refer to [Section 5.3.20](#) for details on the input/output alternate function characteristics (output compare, input capture, external clock, PWM output).

Table 62. TIMx characteristics⁽¹⁾⁽²⁾

Symbol	Parameter	Conditions ⁽³⁾	Min	Max	Unit
$t_{res(TIM)}$	Timer resolution time	AHB/APBx prescaler=1 or 2 or 4, $f_{TIMxCLK} = 180$ MHz	1	-	$t_{TIMxCLK}$
		AHB/APBx prescaler>4, $f_{TIMxCLK} = 90$ MHz	1	-	$t_{TIMxCLK}$
f_{EXT}	Timer external clock frequency on CH1 to CH4	$f_{TIMxCLK} = 180$ MHz	0	$f_{TIMxCLK}/2$	MHz
Res_{TIM}	Timer resolution		-	16/32	bit
t_{MAX_COUNT}	Maximum possible count with 32-bit counter		-	65536×65536	$t_{TIMxCLK}$

1. TIMx is used as a general term to refer to the TIM1 to TIM12 timers.
2. Guaranteed by design.
3. The maximum timer frequency on APB1 or APB2 is up to 180 MHz, by setting the TIMPRE bit in the RCC_DCKCFGR register, if APBx prescaler is 1 or 2 or 4, then $TIMxCLK = HCKL$, otherwise $TIMxCLK = 4 \times PCLKx$.

5.3.23 Communications interfaces

I²C interface characteristics

The I²C interface meets the timings requirements of the I²C-bus specification and user manual rev. 03 for:

- Standard-mode (Sm): with a bit rate up to 100 kbit/s
- Fast-mode (Fm): with a bit rate up to 400 kbit/s.

The I²C timings requirements are guaranteed by design when the I2C peripheral is properly configured (refer to RM0386 reference manual).

The SDA and SCL I/O requirements are met with the following restrictions: the SDA and SCL I/O pins are not “true” open-drain. When configured as open-drain, the PMOS connected between the I/O pin and V_{DD} is disabled, but is still present. Refer to [Section 5.3.20](#) for more details on the I²C I/O characteristics.

All I²C SDA and SCL I/Os embed an analog filter. Refer to the table below for the analog filter characteristics:

Table 63. I2C analog filter characteristics⁽¹⁾

Symbol	Parameter	Min	Max	Unit
t_{AF}	Maximum pulse width of spikes that are suppressed by the analog filter	50 ⁽²⁾	150 ⁽³⁾	ns

1. Guaranteed based on test during characterization.
2. Spikes with widths below $t_{AF(min)}$ are filtered.
3. Spikes with widths above $t_{AF(max)}$ are not filtered

SPI interface characteristics

Unless otherwise specified, the parameters given in [Table 64](#) for the SPI interface are derived from tests performed under the ambient temperature, f_{PCLKx} frequency and V_{DD} supply voltage conditions summarized in [Table 17](#), with the following configuration:

- Output speed is set to $OSPEEDRy[1:0] = 10$
- Capacitive load $C = 30\text{ pF}$
- Measurement points are done at CMOS levels: $0.5 V_{DD}$

Refer to [Section 5.3.20](#) for more details on the input/output alternate function characteristics (NSS, SCK, MOSI, MISO for SPI).

Table 64. SPI dynamic characteristics⁽¹⁾

Symbol	Parameter	Conditions	Min	Typ	Max	Unit
f_{SCK} $1/t_{c(SCK)}$	SPI clock frequency	Master mode, $2.7\text{ V} \leq V_{DD} \leq 3.6\text{ V}$, SPI1,4,5,6,	-	-	45	MHz
		Master mode, $1.71\text{ V} \leq V_{DD} \leq 3.6\text{ V}$, SPI1,4,5,6	-	-	22.5 ⁽²⁾	
		Master transmitter mode, $1.7\text{ V} \leq V_{DD} \leq 3.6\text{ V}$, SPI1,4,5,6	-	-	45	
		Slave full duplex mode, $2.7\text{ V} \leq V_{DD} \leq 3.6\text{ V}$, SPI1,4,5,6	-	-	22.5	
		Slave transmitter mode, $1.71\text{ V} \leq V_{DD} \leq 3.6\text{ V}$, SPI1,4,5,6	-	-	33	
		Slave transmitter mode, $2.7\text{ V} \leq V_{DD} \leq 3.6\text{ V}$, SPI1,4,5,6	-	-	45	
		Slave mode, $1.71\text{ V} \leq V_{DD} \leq 3.6\text{ V}$, SPI2,3	-	-	22.5	
Duty(SCK)	Duty cycle of SPI clock frequency	Slave mode	30	50	70	%

Table 64. SPI dynamic characteristics⁽¹⁾ (continued)

Symbol	Parameter	Conditions	Min	Typ	Max	Unit
$t_{w(SCKH)}$ $t_{w(SCKL)}$	SCK high and low time	Master mode, SPI presc = 2	$T_{PCLK} - 1.5$	T_{PCLK}	$T_{PCLK} + 1.5$	ns
$t_{su(NSS)}$	NSS setup time	Slave mode, SPI presc = 2	$4T_{PCLK}$	-	-	
$t_{h(NSS)}$	NSS hold time	Slave mode, SPI presc = 2	$2T_{PCLK}$	-	-	
$t_{su(MI)}$	Data input setup time	Master mode	2	-	-	
$t_{su(SI)}$		Slave mode	3	-	-	
$t_{h(MI)}$	Data input hold time	Master mode	4	-	-	
$t_{h(SI)}$		Slave mode	2	-	-	
$t_{a(SO)}$	Data output access time	Slave mode, SPI presc = 2	7	-	21	
$t_{dis(SO)}$	Data output disable time	Slave mode	5	-	12	
$t_{v(SO)}$	Data output valid time	Slave mode (after enable edge), $2.7V \leq V_{DD} \leq 3.6V$	-	11	15	
		Slave mode (after enable edge), $1.71V \leq V_{DD} \leq 3.6V$	-	11	11.5	
$t_{h(SO)}$	Data output hold time	Slave mode (after enable edge)	6	-	-	
$t_{v(MO)}$	Data output valid time	Master mode (after enable edge)	-	4.5	5	
$t_{h(MO)}$	Data output hold time	Master mode (after enable edge)	2	-	-	

1. Guaranteed based on test during characterization.
2. Maximum frequency in Slave transmitter mode is determined by the sum of $t_{v(SO)}$ and $t_{su(MI)}$ which has to fit into SCK low or high phase preceding the SCK sampling edge. This value can be achieved when the SPI communicates with a master having $t_{su(MI)} = 0$ while Duty(SCK) = 50%

Figure 40. SPI timing diagram - slave mode and CPHA = 0

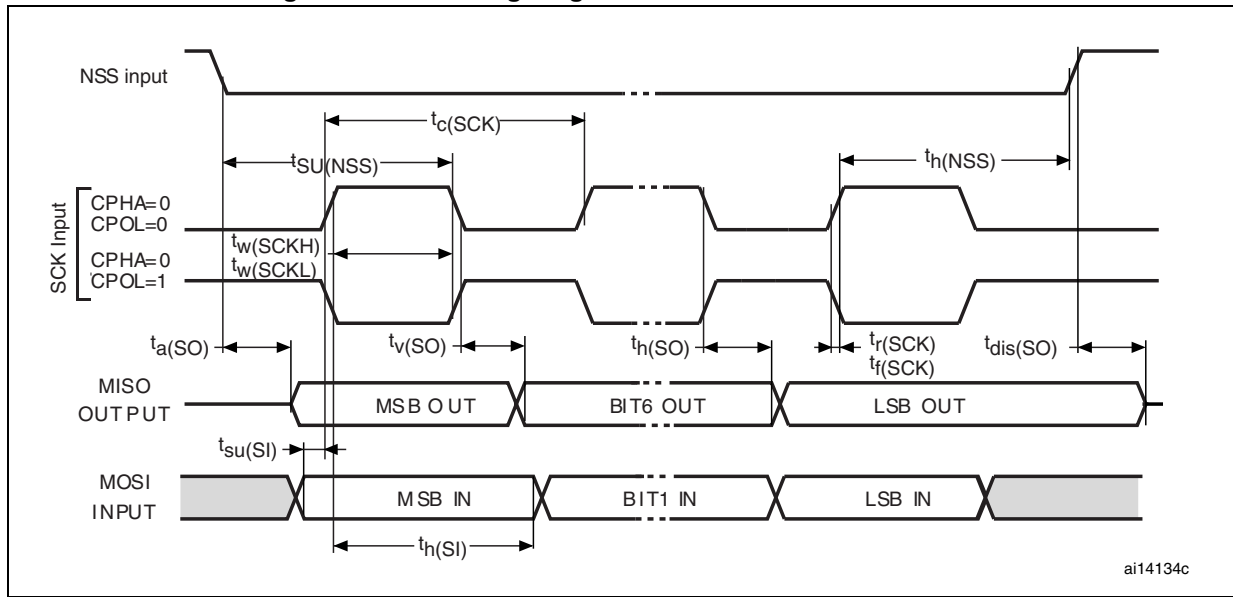

Figure 41. SPI timing diagram - slave mode and CPHA = 1⁽¹⁾

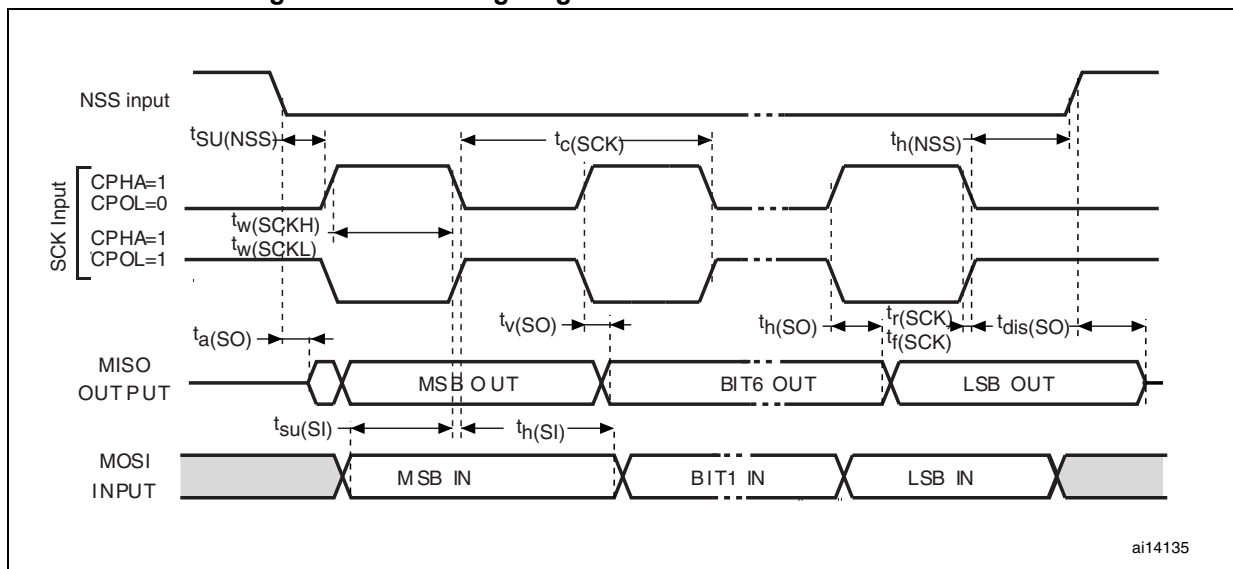
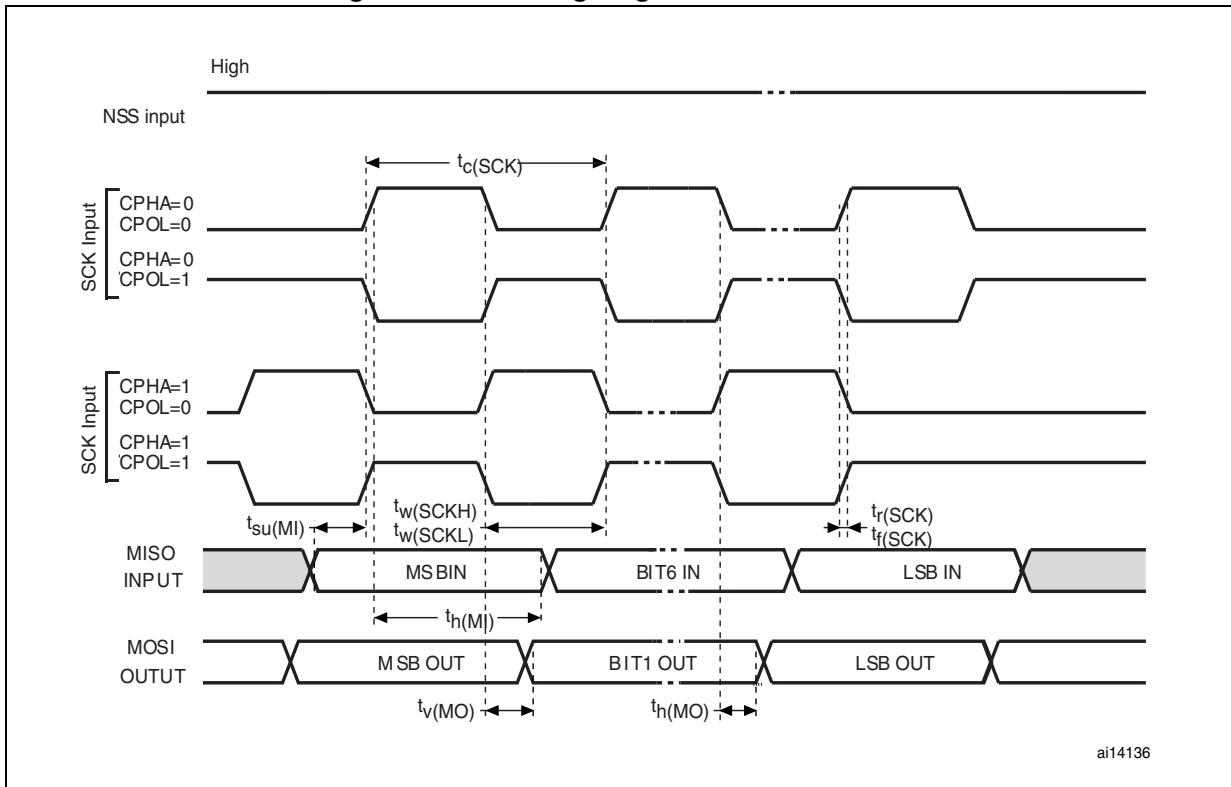

Figure 42. SPI timing diagram - master mode⁽¹⁾



ai14136

I²S interface characteristics

Unless otherwise specified, the parameters given in [Table 65](#) for the I²S interface are derived from tests performed under the ambient temperature, f_{PCLKX} frequency and V_{DD} supply voltage conditions summarized in [Table 17](#), with the following configuration:

- Output speed is set to OSPEEDRy[1:0] = 10
- Capacitive load C = 30 pF
- Measurement points are done at CMOS levels: 0.5 V_{DD}

Refer to [Section 5.3.20](#) for more details on the input/output alternate function characteristics (CK, SD, WS).

Table 65. I²S dynamic characteristics⁽¹⁾

Symbol	Parameter	Conditions	Min	Max	Unit
f_{MCK}	I2S Main clock output	-	256x8K	256x F_s ⁽²⁾	MHz
f_{CK}	I2S clock frequency	Master data	-	64x F_s	
		Slave data	-	64x F_s	
D_{CK}	I2S clock frequency duty cycle	Slave receiver	30	70	%
$t_{v(WS)}$	WS valid time	Master mode	0	5	ns
$t_{h(WS)}$	WS hold time	Master mode	0	-	
$t_{su(WS)}$	WS setup time	Slave mode	3.5	-	
		Slave mode PCM short pulse mode ⁽³⁾	3.5	-	
$t_{h(WS)}$	WS hold time	Slave mode	0.5	-	
		Slave mode PCM short pulse mode ⁽³⁾	1	-	
$t_{su(SD_MR)}$	Data input setup time	Master receiver	5	-	
$t_{su(SD_SR)}$		Slave receiver	1.5	-	
$t_{h(SD_MR)}$	Data input hold time	Master receiver	5	-	
$t_{h(SD_SR)}$		Slave receiver	1.5	-	
$t_{v(SD_ST)}$	Data output valid time	Slave transmitter (after enable edge)	-	19	
$t_{v(SD_MT)}$		Master transmitter (after enable edge)	-	2.50	
$t_{h(SD_ST)}$	Data output hold time	Slave transmitter (after enable edge)	5	-	
$t_{h(SD_MT)}$		Master transmitter (after enable edge)	0	-	

1. Guaranteed based on test during characterization.
2. 128x F_s maximum is 24.756 MHz (APB1 Maximum frequency).
3. Measurement done with respect to I2S_CK rising edge.

Note: Refer to the I2S section of RM0386 reference manual for more details on the sampling frequency (F_s).

f_{MCK} , f_{CK} , and D_{CK} values reflect only the digital peripheral behavior, source clock precision might slightly change the values. The values of these parameters might be slightly impacted by the source clock precision. D_{CK} depends mainly on the value of ODD bit. The digital

contribution leads to a minimum value of $(I2SDIV/(2*I2SDIV+ODD))$ and a maximum value of $(I2SDIV+ODD)/(2*I2SDIV+ODD)$. F_S maximum value is supported for each mode/condition.

Figure 43. I²S slave timing diagram (Philips protocol)⁽¹⁾

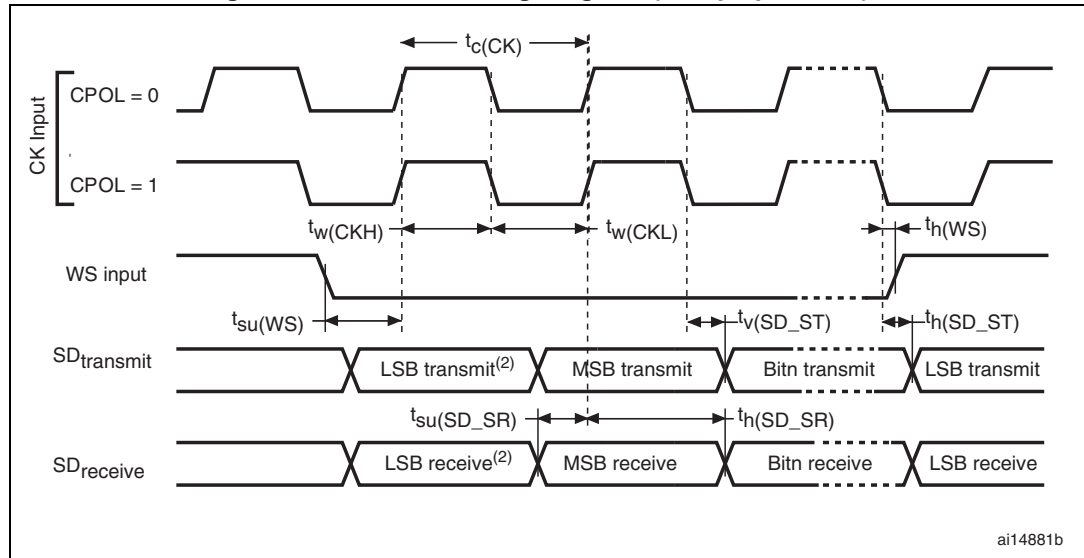

1. .LSB transmit/receive of the previously transmitted byte. No LSB transmit/receive is sent before the first byte.

Figure 44. I²S master timing diagram (Philips protocol)⁽¹⁾

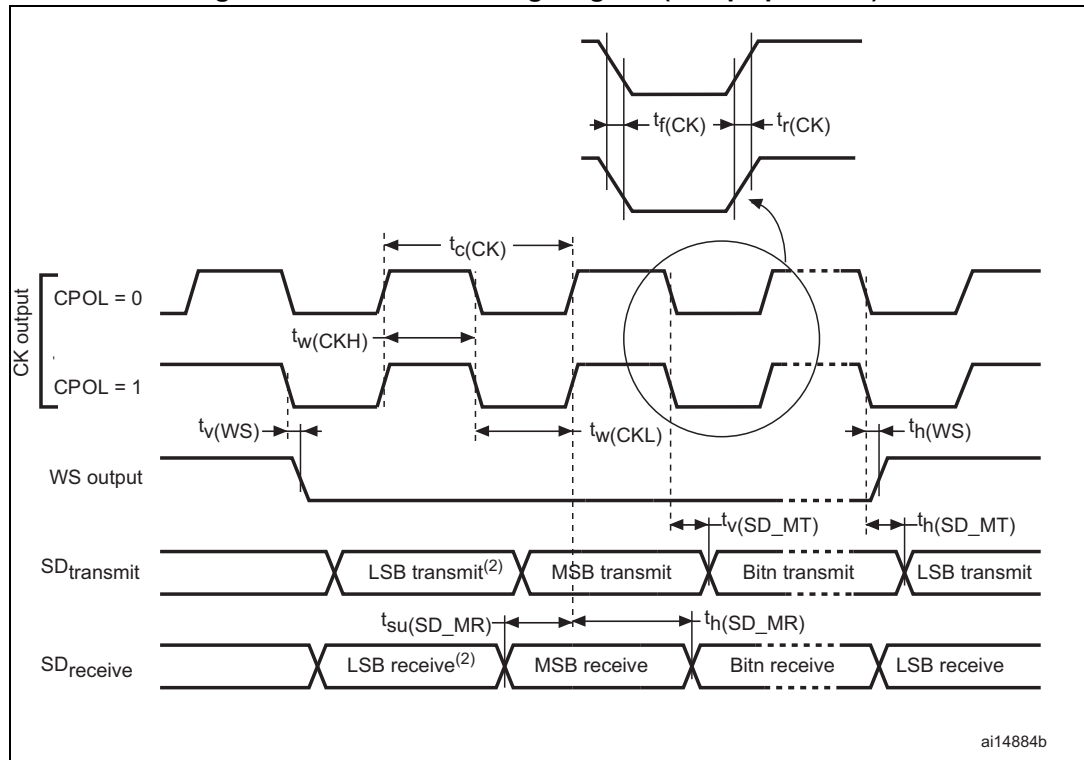

1. LSB transmit/receive of the previously transmitted byte. No LSB transmit/receive is sent before the first byte.

SAI characteristics

Unless otherwise specified, the parameters given in [Table 66](#) for SAI are derived from tests performed under the ambient temperature, f_{PCLKx} frequency and VDD supply voltage conditions summarized in [Table 17](#), with the following configuration:

- Output speed is set to OSPEEDRy[1:0] = 10
- Capacitive load C=30 pF
- Measurement points are performed at CMOS levels: 0.5 V_{DD}

Refer to [Section 5.3.20](#) for more details on the input/output alternate function characteristics (SCK,SD,WS).

Table 66. SAI characteristics⁽¹⁾

Symbol	Parameter	Conditions	Min	Max	Unit
f _{MCKL}	SAI Main clock output	-	256 x 8K	256xFs	MHz
f _{CK}	SAI clock frequency ⁽²⁾	Master data: 32 bits	-	128xFs ⁽³⁾	
		Slave data: 32 bits	-	128xFs	
t _{v(FS)}	FS valid time	Master mode, 2.7V ≤ V _{DD} ≤ 3.6V	-	17	ns
		Master mode, 1.71V ≤ V _{DD} ≤ 3.6V	-	23	
t _{su(FS)}	FS setup time	Slave mode	10	-	
t _{h(FS)}	FS hold time	Slave mode	0	-	
t _{su(SD_MR)}	Data input setup time	Master receiver	1	-	
t _{su(SD_SR)}		Slave receiver	2	-	
t _{h(SD_MR)}	Data input hold time	Master receiver	6	-	
t _{h(SD_SR)}		Slave receiver	1	-	
t _{h(SD_B_ST)}	Data output valid time	Slave transmitter (after enable edge), 2.7V ≤ V _{DD} ≤ 3.6V	-	14	
		Slave transmitter (after enable edge), 1.71V ≤ V _{DD} ≤ 3.6V	-	23	
t _{h(SD_B_ST)}	Data output hold time	Slave transmitter (after enable edge)	9	-	
t _{v(SD_A_MT)}	Data output valid time	Master transmitter (after enable edge), 2.7V ≤ V _{DD} ≤ 3.6V	-	20	
		Master transmitter (after enable edge), 1.71V ≤ V _{DD} ≤ 3.6V	-	26	
t _{h(SD_A_MT)}	Data output hold time	Master transmitter (after enable edge)	10	-	

1. Guaranteed based on test during characterization.
2. APB clock frequency must be at least twice SAI clock frequency.
3. With Fs = 192 kHz.

Figure 45. SAI master timing waveforms

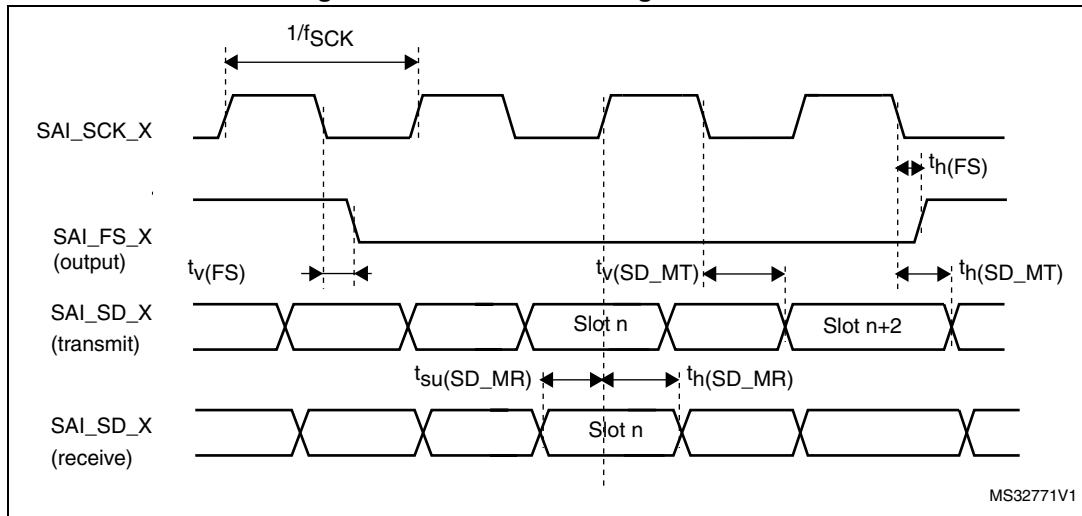
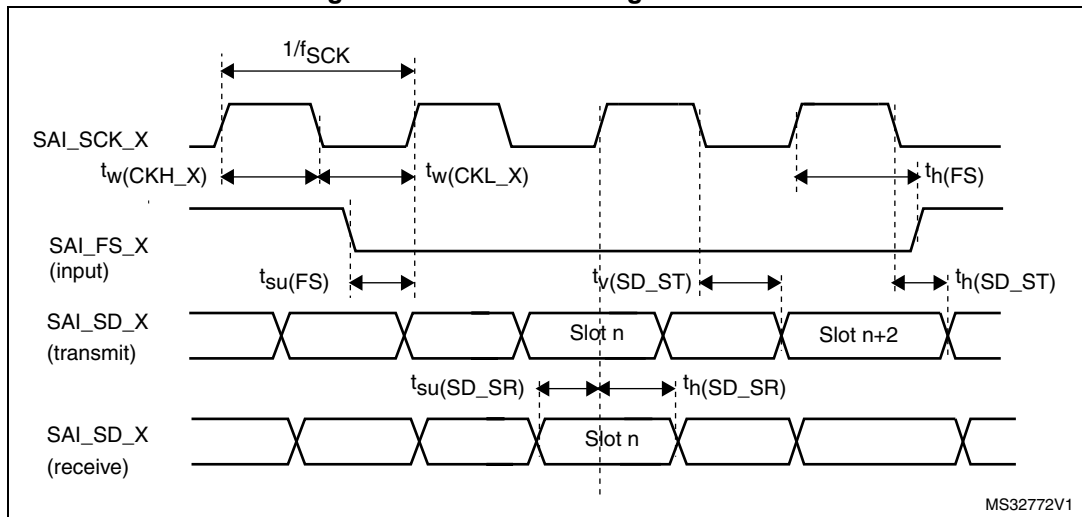

Figure 46. SAI slave timing waveforms



USB OTG full speed (FS) characteristics

This interface is present in both the USB OTG HS and USB OTG FS controllers.

Table 67. USB OTG full speed startup time

Symbol	Parameter	Max	Unit
$t_{STARTUP}^{(1)}$	USB OTG full speed transceiver startup time	1	μs

1. Guaranteed by design.

Table 68. USB OTG full speed DC electrical characteristics

Symbol	Parameter	Conditions	Min. ⁽¹⁾	Typ.	Max. ⁽¹⁾	Unit	
Input levels	V_{DD}	USB OTG full speed transceiver operating voltage	-	3.0 ⁽²⁾	-	3.6	V
	$V_{DI}^{(3)}$	Differential input sensitivity	I(USB_FS_DP/DM, USB_HS_DP/DM)	0.2	-	-	
	$V_{CM}^{(3)}$	Differential common mode range	Includes V_{DI} range	0.8	-	2.5	
	$V_{SE}^{(3)}$	Single ended receiver threshold	-	1.3	-	2.0	
Output levels	V_{OL}	Static output level low	R_L of 1.5 k Ω to 3.6 V ⁽⁴⁾	-	-	0.3	
	V_{OH}	Static output level high	R_L of 15 k Ω to $V_{SS}^{(4)}$	2.8	-	3.6	
R_{PD}	PA11, PA12, PB14, PB15 (USB_FS_DP/DM, USB_HS_DP/DM)	$V_{IN} = V_{DD}$	17	21	24	k Ω	
	PA9, PB13 (OTG_FS_VBUS, OTG_HS_VBUS)		0.65	1.1	2.0		
R_{PU}	PA12, PB15 (USB_FS_DP, USB_HS_DP)	$V_{IN} = V_{SS}$	1.5	1.8	2.1		
	PA9, PB13 (OTG_FS_VBUS, OTG_HS_VBUS)	$V_{IN} = V_{SS}$	0.25	0.37	0.55		

1. All the voltages are measured from the local ground potential.
2. The USB OTG full speed transceiver functionality is ensured down to 2.7 V but not the full USB full speed electrical characteristics which are degraded in the 2.7-to-3.0 V V_{DD} voltage range.
3. Guaranteed by design.
4. R_L is the load connected on the USB OTG full speed drivers.

Note: *When VBUS sensing feature is enabled, PA9 and PB13 should be left at their default state (floating input), not as alternate function. A typical 200 μA current consumption of the sensing block (current to voltage conversion to determine the different sessions) can be observed on PA9 and PB13 when the feature is enabled.*

Figure 47. USB OTG full speed timings: definition of data signal rise and fall time

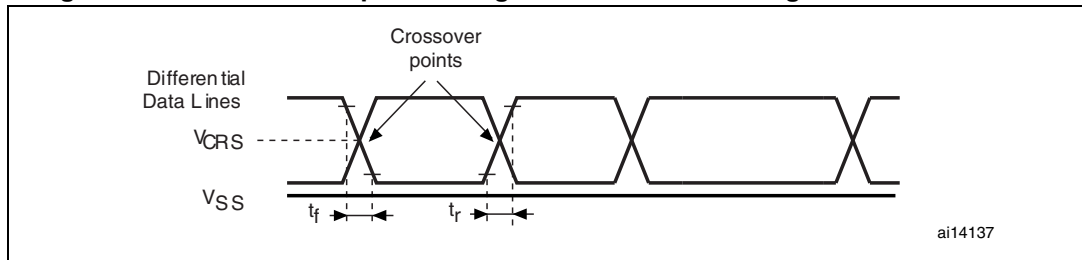

Table 69. USB OTG full speed electrical characteristics⁽¹⁾

Driver characteristics					
Symbol	Parameter	Conditions	Min	Max	Unit
t_r	Rise time ⁽²⁾	$C_L = 50 \text{ pF}$	4	20	ns
t_f	Fall time ⁽²⁾	$C_L = 50 \text{ pF}$	4	20	
t_{rfm}	Rise/ fall time matching	t_r/t_f	90	110	%
V_{CRS}	Output signal crossover voltage	-	1.3	2.0	V
Z_{DRV}	Output driver impedance ⁽³⁾	Driving high or low	28	44	Ω

1. Guaranteed by design.
2. Measured from 10% to 90% of the data signal. For more detailed informations, please refer to USB Specification - Chapter 7 (version 2.0).
3. No external termination series resistors are required on DP (D+) and DM (D-) pins since the matching impedance is included in the embedded driver.

USB high speed (HS) characteristics

Unless otherwise specified, the parameters given in [Table 72](#) for ULPI are derived from tests performed under the ambient temperature, f_{HCLK} frequency summarized in [Table 71](#) and V_{DD} supply voltage conditions summarized in [Table 70](#), with the following configuration:

- Output speed is set to $OSPEEDRy[1:0] = 11$, unless otherwise specified
- Capacitive load $C = 20 \text{ pF} / 15 \text{ pF}$, unless otherwise specified
- Measurement points are done at CMOS levels: $0.5 V_{DD}$.

Refer to [Section 5.3.20](#) for more details on the input/output characteristics.

Table 70. USB HS DC electrical characteristics

Symbol	Parameter	Min. ⁽¹⁾	Max. ⁽¹⁾	Unit
Input level	V_{DD} USB OTG HS operating voltage	1.7	3.6	V

1. All the voltages are measured from the local ground potential.

Table 71. USB HS clock timing parameters⁽¹⁾

Symbol	Parameter		Min	Typ	Max	Unit
-	f _{HCLK} value to guarantee proper operation of USB HS interface		30	-	-	MHz
F _{START_8BIT}	Frequency (first transition)	8-bit ±10%	54	60	66	
F _{STEADY}	Frequency (steady state) ±500 ppm		59.97	60	60.03	
D _{START_8BIT}	Duty cycle (first transition)	8-bit ±10%	40	50	60	%
D _{STEADY}	Duty cycle (steady state) ±500 ppm		49.975	50	50.025	
t _{STEADY}	Time to reach the steady state frequency and duty cycle after the first transition		-	-	1.4	ms
t _{START_DEV}	Clock startup time after the de-assertion of SuspendM	Peripheral	-	-	5.6	ms
t _{START_HOST}		Host	-	-	-	
t _{PREP}	PHY preparation time after the first transition of the input clock		-	-	-	µs

1. Guaranteed by design.

Figure 48. ULPI timing diagram

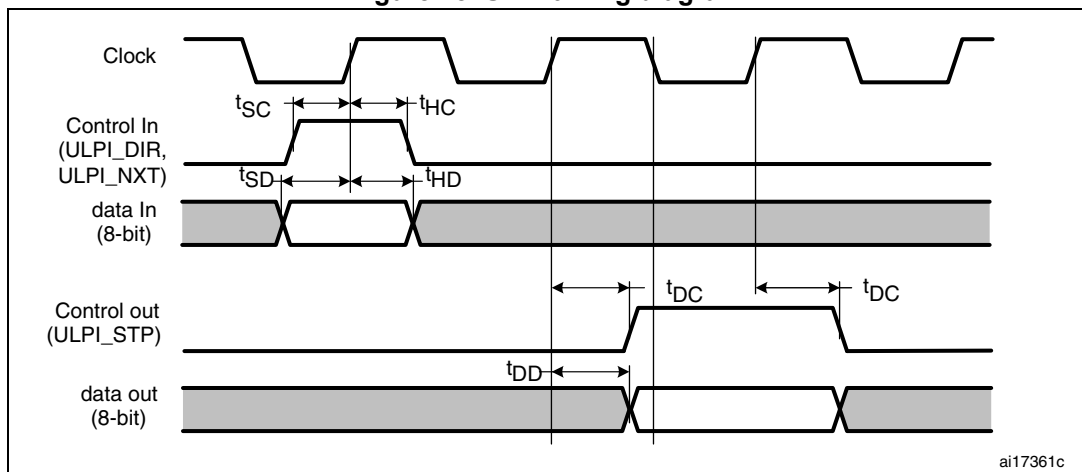

ai17361c

Table 72. Dynamic characteristics: USB ULPI⁽¹⁾

Symbol	Parameter	Conditions	Min.	Typ.	Max.	Unit
t _{SC}	Control in (ULPI_DIR, ULPI_NXT) setup time	-	2.0	-	-	ns
t _{HC}	Control in (ULPI_DIR, ULPI_NXT) hold time	-	1.5	-	-	
t _{SD}	Data in setup time	-	1.0	-	-	
t _{HD}	Data in hold time	-	1.0	-	-	
t _{DC} /t _{DD}	Data/control output delay	2.7 V < V _{DD} < 3.6 V, C _L = 20 pF	-	7.5	9.0	
		2.7 V < V _{DD} < 3.6 V, C _L = 15 pF and -40 < T < 125°C	-	7.5	12.0	
		1.7 V < V _{DD} < 3.6 V, C _L = 15 pF and -40 < T < 90°C	-	7.5	11.5	

1. Guaranteed based on test during characterization.

Ethernet characteristics

Unless otherwise specified, the parameters given in [Table 74](#), [Table 75](#) and [Table 76](#) for SMI, RMII and MII are derived from tests performed under the ambient temperature, f_{HCLK} frequency summarized in [Table 17](#) and V_{DD} supply voltage conditions summarized in [Table 73](#), with the following configuration:

- Output speed is set to OSPEEDRy[1:0] = 10
- Capacitive load C = 30 pF
- Measurement points are done at CMOS levels: 0.5 V_{DD}.

Refer to [Section 5.3.20](#) for more details on the input/output characteristics.

Table 73. Ethernet DC electrical characteristics

Symbol	Parameter	Min. ⁽¹⁾	Max. ⁽¹⁾	Unit
Input level	V _{DD} Ethernet operating voltage	2.7	3.6	V

1. All the voltages are measured from the local ground potential.

[Table 74](#) gives the list of Ethernet MAC signals for the SMI (station management interface) and [Figure 49](#) shows the corresponding timing diagram.

Figure 49. Ethernet SMI timing diagram

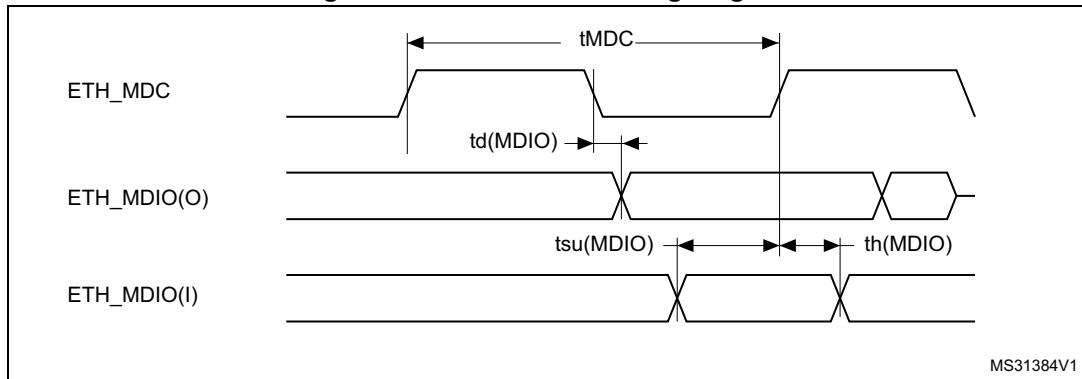

MS31384V1

Table 74. Dynamics characteristics: Ethernet MAC signals for SMI⁽¹⁾

Symbol	Parameter	Min	Typ	Max	Unit
t_{MDC}	MDC cycle time(2.38 MHz)	400	400	403	ns
$T_d(MDIO)$	Write data valid time	$T_{HCLK} - 1$	T_{HCLK}	$T_{HCLK} + 1.5$	
$t_{su}(MDIO)$	Read data setup time	12.5	-	-	
$t_h(MDIO)$	Read data hold time	0	-	-	

1. Guaranteed based on test during characterization.

Table 75 gives the list of Ethernet MAC signals for the RMII and Figure 50 shows the corresponding timing diagram.

Figure 50. Ethernet RMII timing diagram

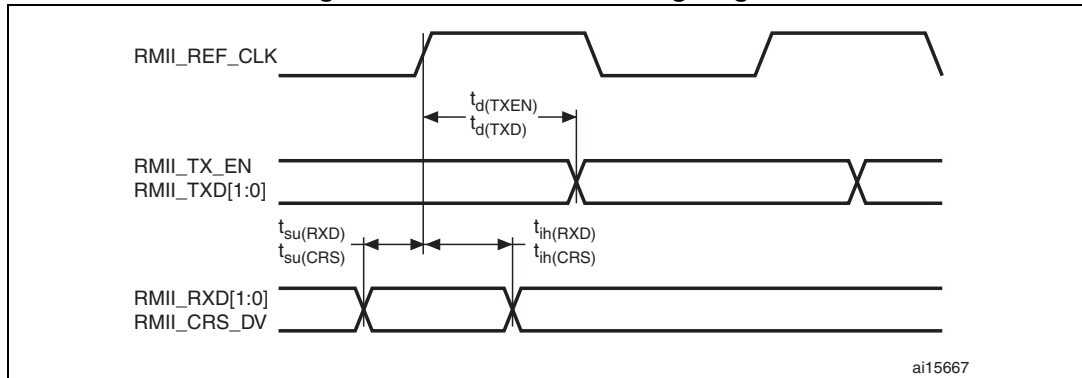

ai15667

Table 75. Dynamics characteristics: Ethernet MAC signals for RMII⁽¹⁾

Symbol	Parameter	Min	Typ	Max	Unit
$t_{su}(RXD)$	Receive data setup time	2.5	-	-	ns
$t_{ih}(RXD)$	Receive data hold time	2.0	-	-	
$t_{su}(CRS)$	Carrier sense setup time	0.5	-	-	
$t_{ih}(CRS)$	Carrier sense hold time	1.5	-	-	
$t_d(TXEN)$	Transmit enable valid delay time	5.5	6.5	11	
$t_d(TXD)$	Transmit data valid delay time	6.0	6.5	11	

1. Guaranteed based on test during characterization.

Table 76 gives the list of Ethernet MAC signals for MII and Figure 50 shows the corresponding timing diagram.

Figure 51. Ethernet MII timing diagram

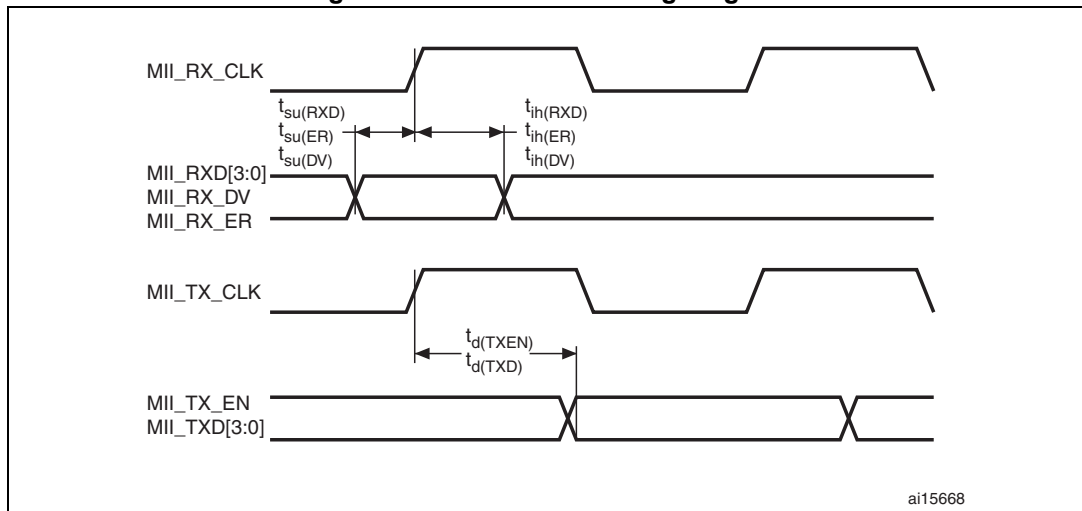

Table 76. Dynamics characteristics: Ethernet MAC signals for MII⁽¹⁾

Symbol	Parameter	Min	Typ	Max	Unit
$t_{su}(RXD)$	Receive data setup time	1	-	-	ns
$t_{ih}(RXD)$	Receive data hold time	3	-	-	
$t_{su}(DV)$	Data valid setup time	0	-	-	
$t_{ih}(DV)$	Data valid hold time	2.5	-	-	
$t_{su}(ER)$	Error setup time	0	-	-	
$t_{ih}(ER)$	Error hold time	2	-	-	
$t_d(TXEN)$	Transmit enable valid delay time	0	7	13	
$t_d(TXD)$	Transmit data valid delay time	0	7	13	

1. Guaranteed based on test during characterization.

CAN (controller area network) interface

Refer to [Section 5.3.20](#) for more details on the input/output alternate function characteristics (CANx_TX and CANx_RX).

5.3.24 12-bit ADC characteristics

Unless otherwise specified, the parameters given in [Table 77](#) are derived from tests performed under the ambient temperature, f_{PCLK2} frequency and V_{DDA} supply voltage conditions summarized in [Table 17](#).

Table 77. ADC characteristics

Symbol	Parameter	Conditions	Min	Typ	Max	Unit
V_{DDA}	Power supply	$V_{DDA} - V_{REF+} < 1.2 \text{ V}$	1.7 ⁽¹⁾	-	3.6	V
V_{REF+}	Positive reference voltage		1.7 ⁽¹⁾	-	V_{DDA}	
f_{ADC}	ADC clock frequency	$V_{DDA} = 1.7^{(1)}$ to 2.4 V	0.6	15	18	MHz
		$V_{DDA} = 2.4$ to 3.6 V	0.6	30	36	
$f_{TRIG}^{(2)}$	External trigger frequency	$f_{ADC} = 30 \text{ MHz}$, 12-bit resolution	-	-	1764	kHz
		-	-	-	17	$1/f_{ADC}$
V_{AIN}	Conversion voltage range ⁽³⁾	-	0 (V_{SSA} or V_{REF-} tied to ground)	-	V_{REF+}	V
$R_{AIN}^{(2)}$	External input impedance	Details in Equation 1	-	-	50	k Ω
$R_{ADC}^{(2)(4)}$	Sampling switch resistance	-	-	-	6	k Ω
$C_{ADC}^{(2)}$	Internal sample and hold capacitor	-	-	4	7	pF
$t_{lat}^{(2)}$	Injection trigger conversion latency	$f_{ADC} = 30 \text{ MHz}$	-	-	0.100	μs
		-	-	-	3 ⁽⁵⁾	$1/f_{ADC}$
$t_{latr}^{(2)}$	Regular trigger conversion latency	$f_{ADC} = 30 \text{ MHz}$	-	-	0.067	μs
		-	-	-	2 ⁽⁵⁾	$1/f_{ADC}$
$t_S^{(2)}$	Sampling time	$f_{ADC} = 30 \text{ MHz}$	0.100	-	16	μs
		-	3	-	480	$1/f_{ADC}$
$t_{STAB}^{(2)}$	Power-up time	-	-	2	3	μs

Table 77. ADC characteristics (continued)

Symbol	Parameter	Conditions	Min	Typ	Max	Unit
t _{CONV} ⁽²⁾	Total conversion time (including sampling time)	f _{ADC} = 30 MHz 12-bit resolution	0.50	-	16.40	μs
		f _{ADC} = 30 MHz 10-bit resolution	0.43	-	16.34	
		f _{ADC} = 30 MHz 8-bit resolution	0.37	-	16.27	
		f _{ADC} = 30 MHz 6-bit resolution	0.30	-	16.20	
		9 to 492 (t _S for sampling +n-bit resolution for successive approximation)				
f _S ⁽²⁾	Sampling rate (f _{ADC} = 30 MHz, and t _S = 3 ADC cycles)	12-bit resolution Single ADC	-	-	2	MSPS
		12-bit resolution Interleave Dual ADC mode	-	-	3.75	
		12-bit resolution Interleave Triple ADC mode	-	-	6	
I _{VREF+} ⁽²⁾	ADC V _{REF} DC current consumption in conversion mode	-	-	300	500	μA
I _{VDDA} ⁽²⁾	ADC V _{DDA} DC current consumption in conversion mode	-	-	1.6	1.8	mA

- V_{DDA} minimum value of 1.7 V is obtained with the use of an external power supply supervisor (refer to [Section 2.19.2](#)).
- Based on test during characterization.
- V_{REF+} is internally connected to V_{DDA} and V_{REF-} is internally connected to V_{SSA}.
- R_{ADC} maximum value is given for V_{DD}=1.7 V, and minimum value for V_{DD}=3.3 V.
- For external triggers, a delay of 1/f_{PCLK2} must be added to the latency specified in [Table 77](#).

Equation 1: R_{AIN} max formula

$$R_{AIN} = \frac{(k - 0.5)}{f_{ADC} \times C_{ADC} \times \ln(2^{N+2})} - R_{ADC}$$

The formula above ([Equation 1](#)) is used to determine the maximum external impedance allowed for an error below 1/4 of LSB. N = 12 (from 12-bit resolution) and k is the number of sampling periods defined in the ADC_SMPR1 register.

Table 78. ADC static accuracy at $f_{ADC} = 18\text{ MHz}^{(1)}$

Symbol	Parameter	Test conditions	Typ	Max ⁽²⁾	Unit
ET	Total unadjusted error	$f_{ADC} = 18\text{ MHz}$ $V_{DDA} = 1.7\text{ to }3.6\text{ V}$ $V_{REF} = 1.7\text{ to }3.6\text{ V}$ $V_{DDA} - V_{REF} < 1.2\text{ V}$	± 3	± 4	LSB
EO	Offset error		± 2	± 3	
EG	Gain error		± 1	± 3	
ED	Differential linearity error		± 1	± 2	
EL	Integral linearity error		± 2	± 3	

1. Better performance could be achieved in restricted V_{DD} , frequency and temperature ranges.
2. Based on test during characterization.

Table 79. ADC static accuracy at $f_{ADC} = 30\text{ MHz}^{(1)}$

Symbol	Parameter	Test conditions	Typ	Max ⁽²⁾	Unit
ET	Total unadjusted error	$f_{ADC} = 30\text{ MHz}$, $R_{AIN} < 10\text{ k}\Omega$, $V_{DDA} = 2.4\text{ to }3.6\text{ V}$, $V_{REF} = 1.7\text{ to }3.6\text{ V}$, $V_{DDA} - V_{REF} < 1.2\text{ V}$	± 2	± 5	LSB
EO	Offset error		± 1.5	± 2.5	
EG	Gain error		± 1.5	± 3	
ED	Differential linearity error		± 1	± 2	
EL	Integral linearity error		± 1.5	± 3	

1. Better performance could be achieved in restricted V_{DD} , frequency and temperature ranges.
2. Based on test during characterization.

Table 80. ADC static accuracy at $f_{ADC} = 36\text{ MHz}^{(1)}$

Symbol	Parameter	Test conditions	Typ	Max ⁽²⁾	Unit
ET	Total unadjusted error	$f_{ADC} = 36\text{ MHz}$, $V_{DDA} = 2.4\text{ to }3.6\text{ V}$, $V_{REF} = 1.7\text{ to }3.6\text{ V}$ $V_{DDA} - V_{REF} < 1.2\text{ V}$	± 4	± 7	LSB
EO	Offset error		± 2	± 3	
EG	Gain error		± 3	± 6	
ED	Differential linearity error		± 2	± 3	
EL	Integral linearity error		± 3	± 6	

1. Better performance could be achieved in restricted V_{DD} , frequency and temperature ranges.
2. Based on test during characterization.

Table 81. ADC dynamic accuracy at $f_{ADC} = 18$ MHz - limited test conditions⁽¹⁾

Symbol	Parameter	Test conditions	Min	Typ	Max	Unit
ENOB	Effective number of bits	$f_{ADC} = 18$ MHz $V_{DDA} = V_{REF+} = 1.7$ V Input Frequency = 20 KHz Temperature = 25 °C	10.3	10.4	-	bits
SINAD	Signal-to-noise and distortion ratio		64	64.2	-	dB
SNR	Signal-to-noise ratio		64	65	-	
THD	Total harmonic distortion		- 67	- 72	-	

1. Guaranteed based on test during characterization.

Table 82. ADC dynamic accuracy at $f_{ADC} = 36$ MHz - limited test conditions⁽¹⁾

Symbol	Parameter	Test conditions	Min	Typ	Max	Unit
ENOB	Effective number of bits	$f_{ADC} = 36$ MHz $V_{DDA} = V_{REF+} = 3.3$ V Input Frequency = 20 KHz Temperature = 25 °C	10.6	10.8	-	bits
SINAD	Signal-to noise and distortion ratio		66	67	-	dB
SNR	Signal-to noise ratio		64	68	-	
THD	Total harmonic distortion		- 70	- 72	-	

1. Guaranteed based on test during characterization.

Note: ADC accuracy vs. negative injection current: injecting a negative current on any analog input pins should be avoided as this significantly reduces the accuracy of the conversion being performed on another analog input. It is recommended to add a Schottky diode (pin to ground) to analog pins which may potentially inject negative currents.

Any positive injection current within the limits specified for $I_{INJ(PIN)}$ and $\Sigma I_{INJ(PIN)}$ in [Section 5.3.20](#) does not affect the ADC accuracy.

Figure 52. ADC accuracy characteristics

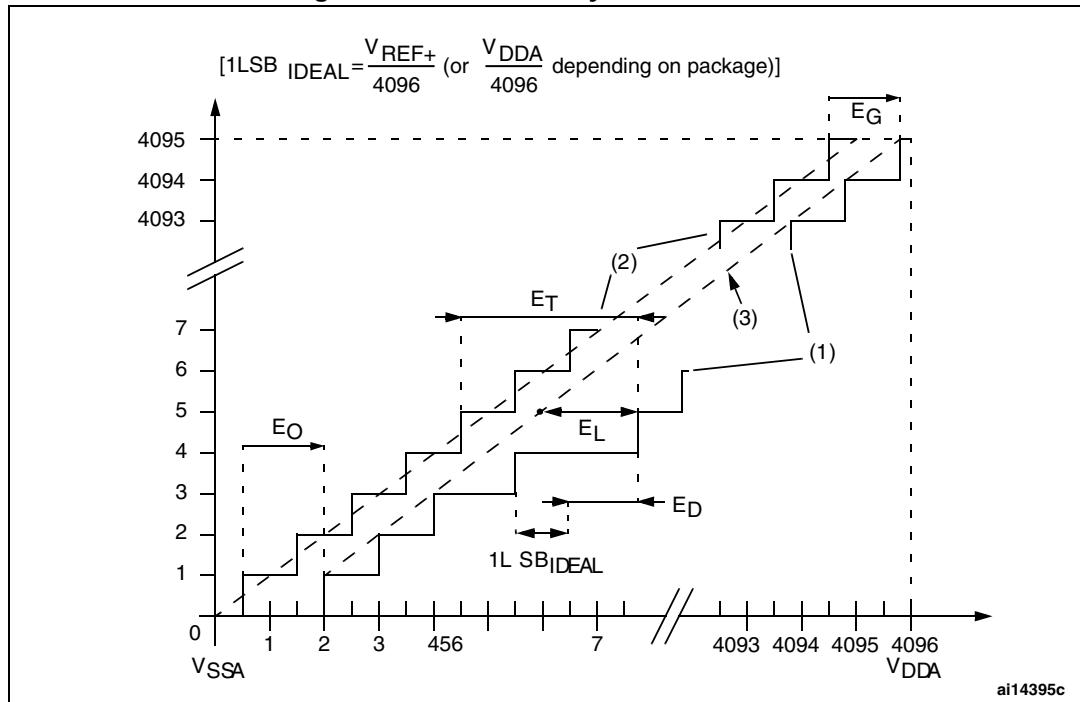

1. See also [Table 79](#).
2. Example of an actual transfer curve.
3. Ideal transfer curve.
4. End point correlation line.
5. E_T = Total Unadjusted Error: maximum deviation between the actual and the ideal transfer curves.
 E_O = Offset Error: deviation between the first actual transition and the first ideal one.
 E_G = Gain Error: deviation between the last ideal transition and the last actual one.
 E_D = Differential Linearity Error: maximum deviation between actual steps and the ideal one.
 E_L = Integral Linearity Error: maximum deviation between any actual transition and the end point correlation line.

Figure 53. Typical connection diagram using the ADC

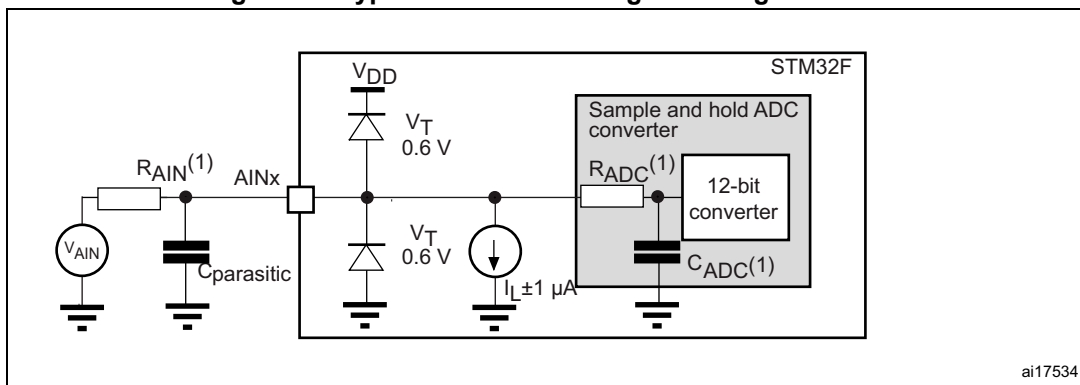

1. Refer to [Table 77](#) for the values of R_{AIN} , R_{ADC} and C_{ADC} .
2. $C_{parasitic}$ represents the capacitance of the PCB (dependent on soldering and PCB layout quality) plus the pad capacitance (roughly 5 pF). A high $C_{parasitic}$ value downgrades conversion accuracy. To remedy this, f_{ADC} should be reduced.

General PCB design guidelines

Power supply decoupling should be performed as shown in *Figure 54* or *Figure 55*, depending on whether V_{REF+} is connected to V_{DDA} or not. The 10 nF capacitors should be ceramic (good quality). They should be placed them as close as possible to the chip.

Figure 54. Power supply and reference decoupling (V_{REF+} not connected to V_{DDA})

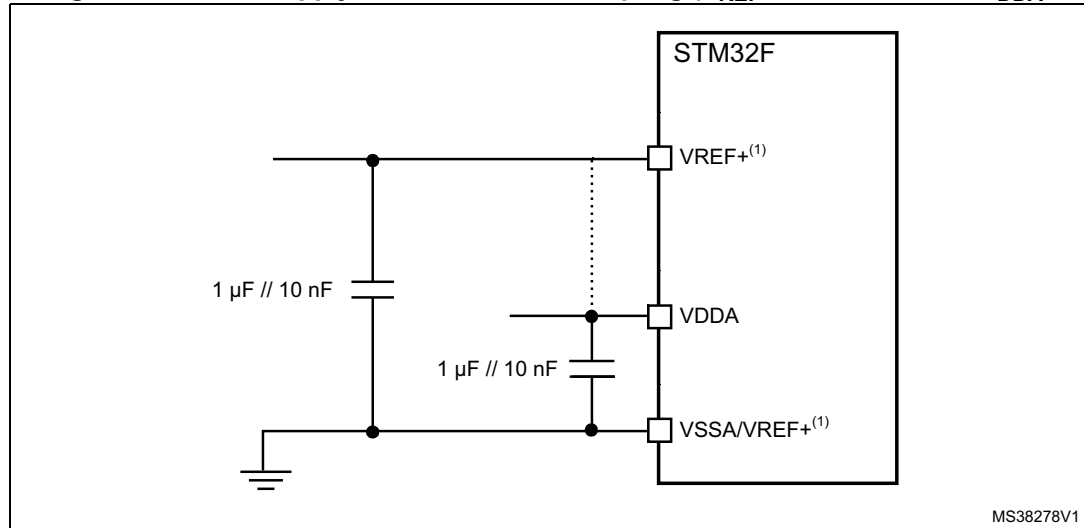

1. V_{REF+} and V_{REF-} inputs are both available on UFBGA176. V_{REF+} is also available on LQFP100, LQFP144, and LQFP176. When V_{REF+} and V_{REF-} are not available, they are internally connected to V_{DDA} and V_{SSA} .

Figure 55. Power supply and reference decoupling (V_{REF+} connected to V_{DDA})

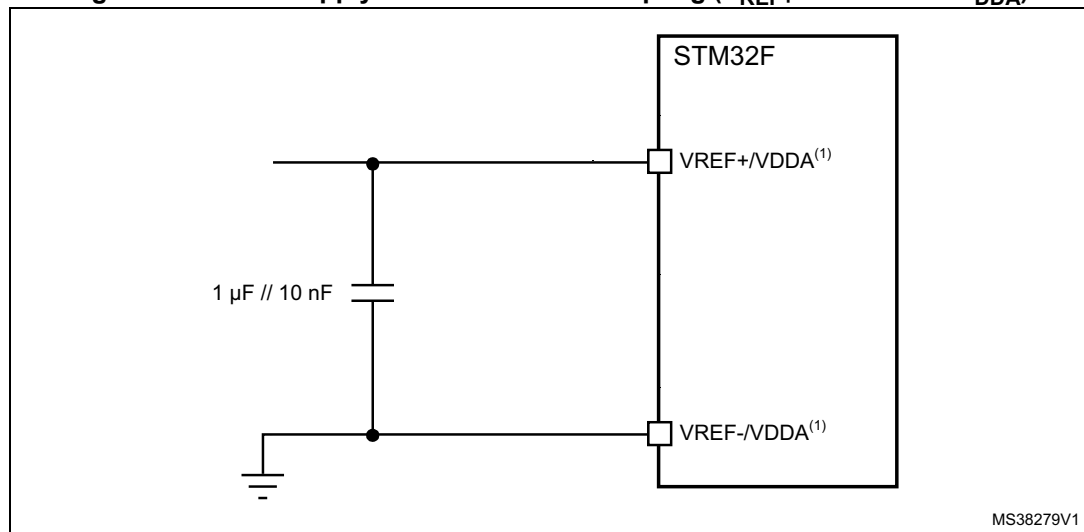

1. V_{REF+} and V_{REF-} inputs are both available on UFBGA176. V_{REF+} is also available on LQFP100, LQFP144, and LQFP176. When V_{REF+} and V_{REF-} are not available, they are internally connected to V_{DDA} and V_{SSA} .

5.3.25 Temperature sensor characteristics

Table 83. Temperature sensor characteristics

Symbol	Parameter	Min	Typ	Max	Unit
$T_L^{(1)}$	V_{SENSE} linearity with temperature	-	± 1	± 2	$^{\circ}\text{C}$
Avg_Slope ⁽¹⁾	Average slope	-	2.5	-	mV/ $^{\circ}\text{C}$
$V_{25}^{(1)}$	Voltage at 25 $^{\circ}\text{C}$	-	0.76	-	V
$t_{START}^{(2)}$	Startup time	-	6	10	μs
$T_{S_temp}^{(2)}$	ADC sampling time when reading the temperature (1 $^{\circ}\text{C}$ accuracy)	10	-	-	

1. Based on test during characterization.
2. Guaranteed by design.

Table 84. Temperature sensor calibration values

Symbol	Parameter	Memory address
TS_CAL1	TS ADC raw data acquired at temperature of 30 $^{\circ}\text{C}$, $V_{DDA} = 3.3\text{ V}$	0x1FFF 7A2C - 0x1FFF 7A2D
TS_CAL2	TS ADC raw data acquired at temperature of 110 $^{\circ}\text{C}$, $V_{DDA} = 3.3\text{ V}$	0x1FFF 7A2E - 0x1FFF 7A2F

5.3.26 V_{BAT} monitoring characteristics

Table 85. V_{BAT} monitoring characteristics

Symbol	Parameter	Min	Typ	Max	Unit
R	Resistor bridge for V_{BAT}	-	50	-	K Ω
Q	Ratio on V_{BAT} measurement	-	4	-	
$E_r^{(1)}$	Error on Q	-1	-	+1	%
$T_{S_vbat}^{(2)(2)}$	ADC sampling time when reading the V_{BAT} 1 mV accuracy	5	-	-	μs

1. Guaranteed by design.
2. Shortest sampling time can be determined in the application by multiple iterations.

5.3.27 Reference voltage

The parameters given in [Table 86](#) are derived from tests performed under ambient temperature and V_{DD} supply voltage conditions summarized in [Table 17](#).

Table 86. internal reference voltage

Symbol	Parameter	Conditions	Min	Typ	Max	Unit
V_{REFINT}	Internal reference voltage	$-40\text{ }^{\circ}\text{C} < T_A < +105\text{ }^{\circ}\text{C}$	1.18	1.21	1.24	V
$T_{S_vrefint}^{(1)}$	ADC sampling time when reading the internal reference voltage		10	-	-	μs
$V_{RERINT_s}^{(2)}$	Internal reference voltage spread over the temperature range	$V_{DD} = 3\text{V} \pm 10\text{mV}$	-	3	5	mV

Table 86. internal reference voltage (continued)

Symbol	Parameter	Conditions	Min	Typ	Max	Unit
$T_{\text{Coeff}}^{(2)}$	Temperature coefficient		-	30	50	ppm/°C
$t_{\text{START}}^{(2)}$	Startup time		-	6	10	µs

- Shortest sampling time can be determined in the application by multiple iterations.
- Guaranteed by design

Table 87. Internal reference voltage calibration values

Symbol	Parameter	Memory address
$V_{\text{REFIN_CAL}}$	Raw data acquired at temperature of 30 °C $V_{\text{DDA}} = 3.3 \text{ V}$	0x1FFF 7A2A - 0x1FFF 7A2B

5.3.28 DAC electrical characteristics

Table 88. DAC characteristics

Symbol	Parameter	Min	Typ	Max	Unit	Comments
V_{DDA}	Analog supply voltage	1.7 ⁽¹⁾	-	3.6	V	-
$V_{\text{REF+}}$	Reference supply voltage	1.7 ⁽¹⁾	-	3.6	V	$V_{\text{REF+}} \leq V_{\text{DDA}}$
V_{SSA}	Ground	0	-	0	V	-
$R_{\text{LOAD}}^{(2)}$	Resistive load with buffer ON	5	-	-	kΩ	-
$R_{\text{O}}^{(2)}$	Impedance output with buffer OFF	-	-	15	kΩ	When the buffer is OFF, the Minimum resistive load between DAC_OUT and V_{SS} to have a 1% accuracy is 1.5 MΩ
$C_{\text{LOAD}}^{(2)}$	Capacitive load	-	-	50	pF	Maximum capacitive load at DAC_OUT pin (when the buffer is ON).
$\text{DAC_OUT}_{\text{min}}^{(2)}$	Lower DAC_OUT voltage with buffer ON	0.2	-	-	V	It gives the maximum output excursion of the DAC. It corresponds to 12-bit input code (0x0E0) to (0xF1C) at $V_{\text{REF+}} = 3.6 \text{ V}$ and (0x1C7) to (0xE38) at $V_{\text{REF+}} = 1.7 \text{ V}$
$\text{DAC_OUT}_{\text{max}}^{(2)}$	Higher DAC_OUT voltage with buffer ON	-	-	$V_{\text{DDA}} - 0.2$	V	
$\text{DAC_OUT}_{\text{min}}^{(2)}$	Lower DAC_OUT voltage with buffer OFF	-	0.5	-	mV	It gives the maximum output excursion of the DAC.
$\text{DAC_OUT}_{\text{max}}^{(2)}$	Higher DAC_OUT voltage with buffer OFF	-	-	$V_{\text{REF+}} - 1\text{LSB}$	V	
$I_{\text{VREF+}}^{(4)}$	DAC DC V_{REF} current consumption in quiescent mode (Standby mode)	-	170	240	µA	With no load, worst code (0x800) at $V_{\text{REF+}} = 3.6 \text{ V}$ in terms of DC consumption on the inputs
		-	50	75		With no load, worst code (0xF1C) at $V_{\text{REF+}} = 3.6 \text{ V}$ in terms of DC consumption on the inputs

Table 88. DAC characteristics (continued)

Symbol	Parameter	Min	Typ	Max	Unit	Comments
$I_{DDA}^{(4)}$	DAC DC VDDA current consumption in quiescent mode ⁽³⁾	-	280	380	μA	With no load, middle code (0x800) on the inputs
		-	475	625	μA	With no load, worst code (0xF1C) at $V_{REF+} = 3.6\text{ V}$ in terms of DC consumption on the inputs
$DNL^{(4)}$	Differential non linearity Difference between two consecutive code-1LSB)	-	-	± 0.5	LSB	Given for the DAC in 10-bit configuration.
		-	-	± 2	LSB	Given for the DAC in 12-bit configuration.
$INL^{(4)}$	Integral non linearity (difference between measured value at Code i and the value at Code i on a line drawn between Code 0 and last Code 1023)	-	-	± 1	LSB	Given for the DAC in 10-bit configuration.
		-	-	± 4	LSB	Given for the DAC in 12-bit configuration.
Offset ⁽⁴⁾	Offset error (difference between measured value at Code (0x800) and the ideal value = $V_{REF+}/2$)	-	-	± 10	mV	Given for the DAC in 12-bit configuration
		-	-	± 3	LSB	Given for the DAC in 10-bit at $V_{REF+} = 3.6\text{ V}$
		-	-	± 12	LSB	Given for the DAC in 12-bit at $V_{REF+} = 3.6\text{ V}$
Gain error ⁽⁴⁾	Gain error	-	-	± 0.5	%	Given for the DAC in 12-bit configuration
$t_{SETTLING}^{(4)}$	Settling time (full scale: for a 10-bit input code transition between the lowest and the highest input codes when DAC_OUT reaches final value $\pm 4\text{LSB}$)	-	3	6	μs	$C_{LOAD} \leq 50\text{ pF}$, $R_{LOAD} \geq 5\text{ k}\Omega$
THD ⁽⁴⁾	Total Harmonic Distortion Buffer ON	-	-	-	dB	$C_{LOAD} \leq 50\text{ pF}$, $R_{LOAD} \geq 5\text{ k}\Omega$
Update rate ⁽²⁾	Max frequency for a correct DAC_OUT change when small variation in the input code (from code i to i+1LSB)	-	-	1	MS/s	$C_{LOAD} \leq 50\text{ pF}$, $R_{LOAD} \geq 5\text{ k}\Omega$
$t_{WAKEUP}^{(4)}$	Wakeup time from off state (Setting the ENx bit in the DAC Control register)	-	6.5	10	μs	$C_{LOAD} \leq 50\text{ pF}$, $R_{LOAD} \geq 5\text{ k}\Omega$ input code between lowest and highest possible ones.
PSRR+ ⁽²⁾	Power supply rejection ratio (to V_{DDA}) (static DC measurement)	-	-67	-40	dB	No R_{LOAD} , $C_{LOAD} = 50\text{ pF}$

- V_{DDA} minimum value of 1.7 V is obtained with the use of an external power supply supervisor (refer to [Section 2.19.2](#)).
- Guaranteed by design.
- The quiescent mode corresponds to a state where the DAC maintains a stable output level to ensure that no dynamic consumption occurs.
- Guaranteed based on test during characterization.

Figure 56. 12-bit buffered/non-buffered DAC

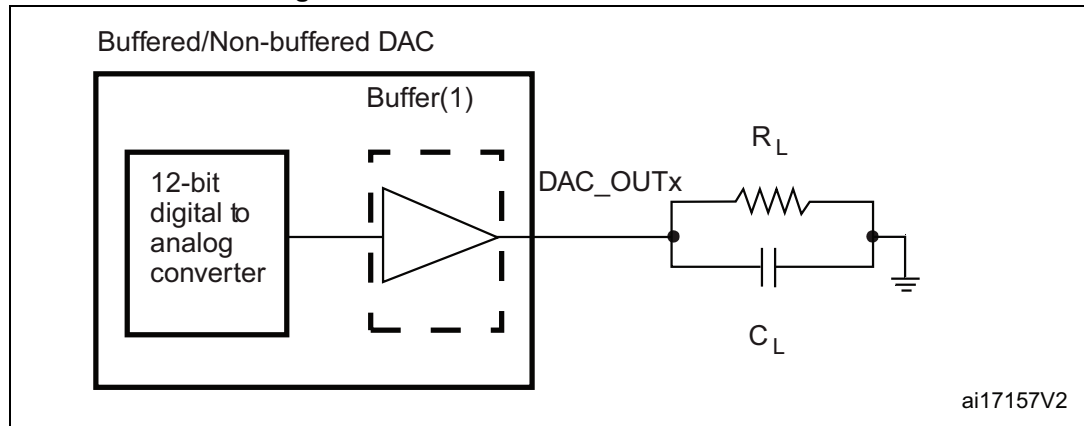

1. The DAC integrates an output buffer that can be used to reduce the output impedance and to drive external loads directly without the use of an external operational amplifier. The buffer can be bypassed by configuring the BOFFx bit in the DAC_CR register.

5.3.29 FMC characteristics

Unless otherwise specified, the parameters given in Tables 89 through 102 for the FMC interface are derived from tests performed under the ambient temperature, f_{HCLK} frequency and V_{DD} supply voltage conditions summarized in Table 17, with the following configuration:

- Output speed is set to OSPEEDRy[1:0] = 11
- Measurement points are done at CMOS levels: $0.5 V_{DD}$

Refer to Section 5.3.20 for more details on the input/output characteristics.

Asynchronous waveforms and timings

Figures 57 through 60 represent asynchronous waveforms, and Tables 89 through 96 provide the corresponding timings. The results shown in these tables are obtained with the following FMC configuration:

- AddressSetupTime = 0x1
- AddressHoldTime = 0x1
- DataSetupTime = 0x1 (except for asynchronous NWAIT mode, DataSetupTime = 0x5)
- BusTurnAroundDuration = 0x0
- Capacitive load $C_L = 30 \text{ pF}$

Figure 57. Asynchronous non-multiplexed SRAM/PSRAM/NOR read waveforms

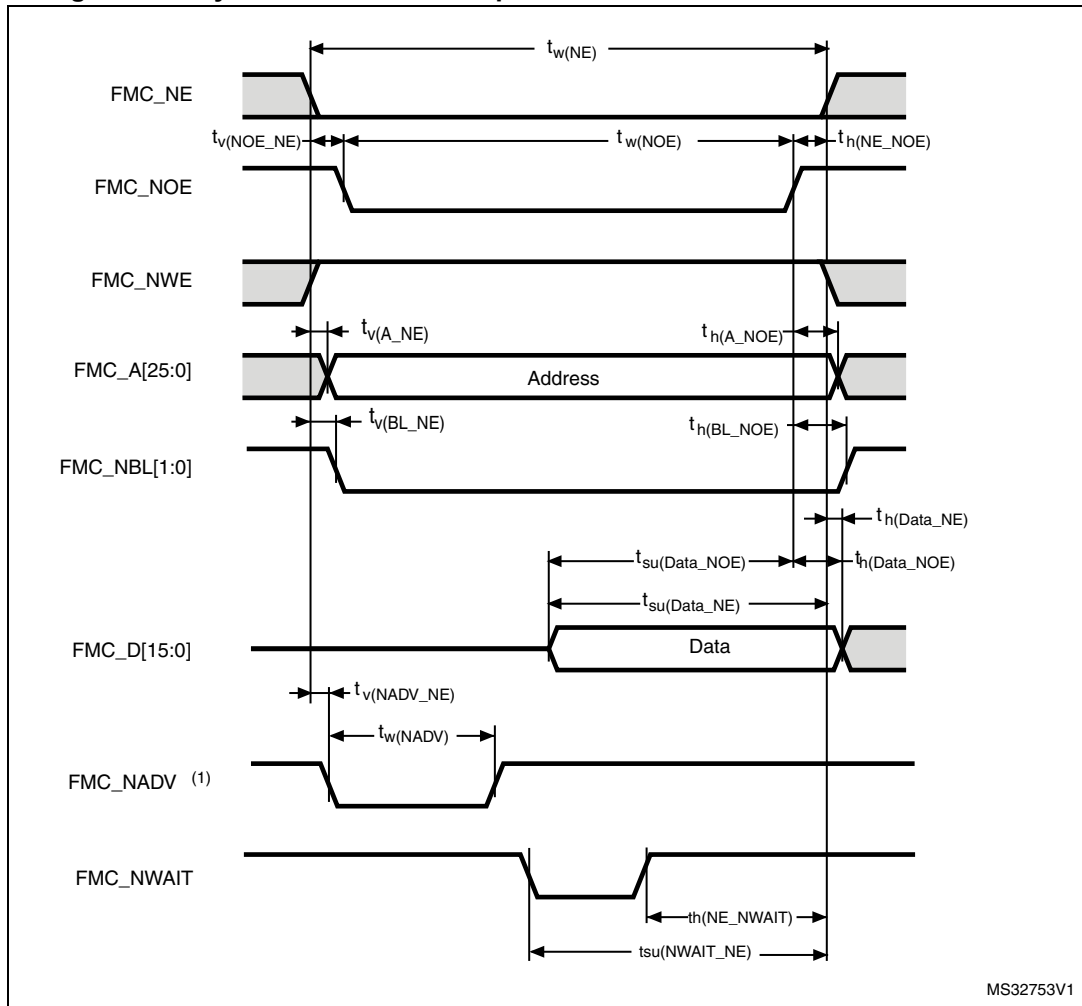

1. Mode 2/B, C and D only. In Mode 1, FMC_NADV is not used.

Table 89. Asynchronous non-multiplexed SRAM/PSRAM/NOR - read timings⁽¹⁾

Symbol	Parameter	Min	Max	Unit
$t_{w(NE)}$	FMC_NE low time	$2T_{HCLK} - 0.5$	$2 T_{HCLK}+0.5$	ns
$t_{v(NOE_NE)}$	FMC_NEx low to FMC_NOE low	0	1	
$t_{w(NOE)}$	FMC_NOE low time	$2T_{HCLK}$	$2T_{HCLK} + 0.5$	
$t_{h(NE_NOE)}$	FMC_NOE high to FMC_NE high hold time	0	-	
$t_{v(A_NE)}$	FMC_NEx low to FMC_A valid	-	2	
$t_{h(A_NOE)}$	Address hold time after FMC_NOE high	0	-	
$t_{v(BL_NE)}$	FMC_NEx low to FMC_BL valid	-	2	
$t_{h(BL_NOE)}$	FMC_BL hold time after FMC_NOE high	0	-	
$t_{su(Data_NE)}$	Data to FMC_NEx high setup time	$T_{HCLK} + 2.5$	-	
$t_{su(Data_NOE)}$	Data to FMC_NOEx high setup time	$T_{HCLK} + 2$	-	
$t_{h(Data_NOE)}$	Data hold time after FMC_NOE high	0	-	
$t_{h(Data_NE)}$	Data hold time after FMC_NEx high	0	-	
$t_{v(NADV_NE)}$	FMC_NEx low to FMC_NADV low	-	0	
$t_{w(NADV)}$	FMC_NADV low time	-	$T_{HCLK} + 1$	

1. Based on test during characterization.

Table 90. Asynchronous non-multiplexed SRAM/PSRAM/NOR read - NWAIT timings⁽¹⁾

Symbol	Parameter	Min	Max	Unit
$t_{w(NE)}$	FMC_NE low time	$7T_{HCLK}+0.5$	$7T_{HCLK}+1$	ns
$t_{w(NOE)}$	FMC_NWE low time	$5T_{HCLK} - 1.5$	$5T_{HCLK} + 2$	
$t_{su(NWAIT_NE)}$	FMC_NWAIT valid before FMC_NEx high	$5T_{HCLK}+1.5$	-	
$t_{h(NE_NWAIT)}$	FMC_NEx hold time after FMC_NWAIT invalid	$4T_{HCLK}+1$	-	

1. Based on test during characterization.

Figure 58. Asynchronous non-multiplexed SRAM/PSRAM/NOR write waveforms

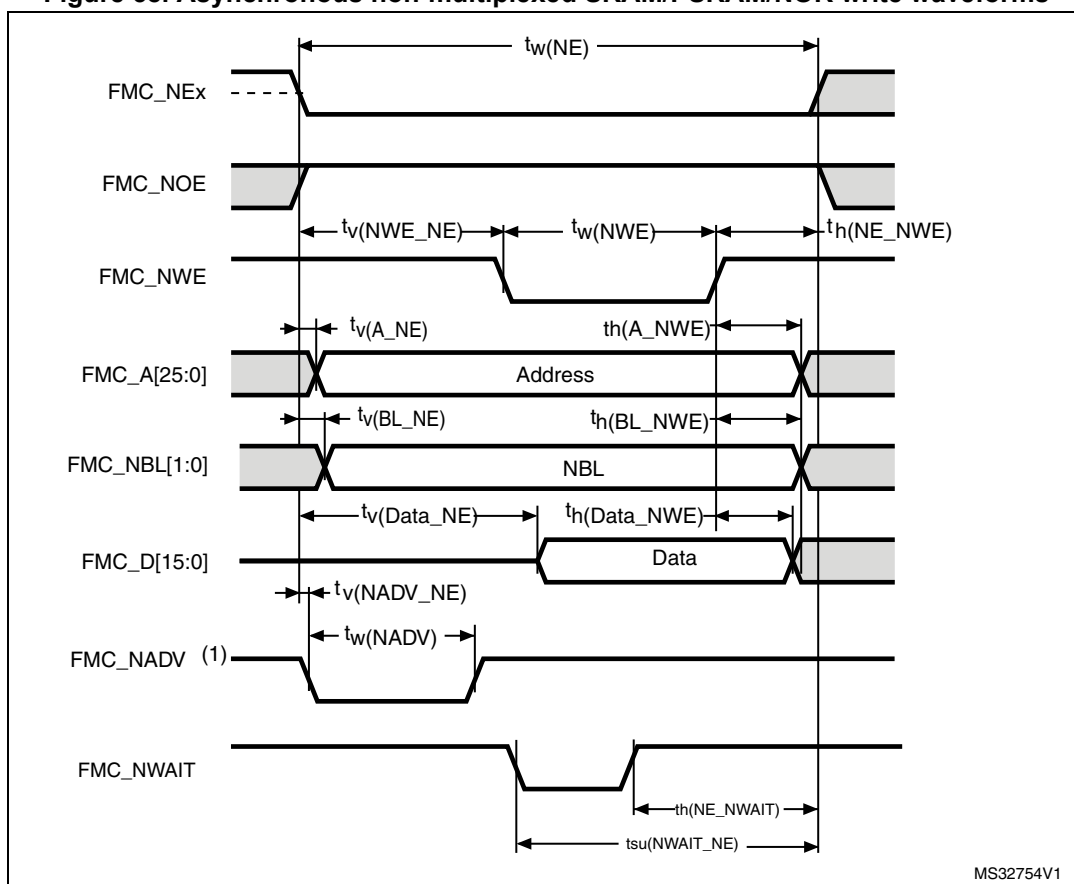

1. Mode 2/B, C and D only. In Mode 1, FMC_NADV is not used.

Table 91. Asynchronous non-multiplexed SRAM/PSRAM/NOR write timings⁽¹⁾

Symbol	Parameter	Min	Max	Unit
$t_{w(NE)}$	FMC_NE low time	$3T_{HCLK}$	$3T_{HCLK}+1$	ns
$t_{v(NWE_NE)}$	FMC_NEx low to FMC_NWE low	$T_{HCLK} - 0.5$	$T_{HCLK} + 0.5$	
$t_{w(NWE)}$	FMC_NWE low time	T_{HCLK}	$T_{HCLK} + 0.5$	
$t_{h(NE_NWE)}$	FMC_NWE high to FMC_NE high hold time	$T_{HCLK} + 1.5$	-	
$t_{v(A_NE)}$	FMC_NEx low to FMC_A valid	-	0	
$t_{h(A_NWE)}$	Address hold time after FMC_NWE high	$T_{HCLK}+0.5$	-	
$t_{v(BL_NE)}$	FMC_NEx low to FMC_BL valid	-	1.5	
$t_{h(BL_NWE)}$	FMC_BL hold time after FMC_NWE high	$T_{HCLK}+0.5$	-	
$t_{v(Data_NE)}$	Data to FMC_NEx low to Data valid	-	$T_{HCLK} + 2$	
$t_{h(Data_NWE)}$	Data hold time after FMC_NWE high	$T_{HCLK}+0.5$	-	
$t_{v(NADV_NE)}$	FMC_NEx low to FMC_NADV low	-	0.5	
$t_{w(NADV)}$	FMC_NADV low time	-	$T_{HCLK} + 0.5$	

1. Based on test during characterization.

Table 92. Asynchronous non-multiplexed SRAM/PSRAM/NOR write - NWAIT timings⁽¹⁾

Symbol	Parameter	Min	Max	Unit
$t_{w(NE)}$	FMC_NE low time	$8T_{HCLK}+1$	$8T_{HCLK}+2$	ns
$t_{w(NWE)}$	FMC_NWE low time	$6T_{HCLK} - 1$	$6T_{HCLK}+2$	
$t_{su(NWAIT_NE)}$	FMC_NWAIT valid before FMC_NEx high	$6T_{HCLK}+1.5$	-	
$t_h(NE_NWAIT)$	FMC_NEx hold time after FMC_NWAIT invalid	$4T_{HCLK}+1$	-	

1. Based on test during characterization.

Figure 59. Asynchronous multiplexed PSRAM/NOR read waveforms

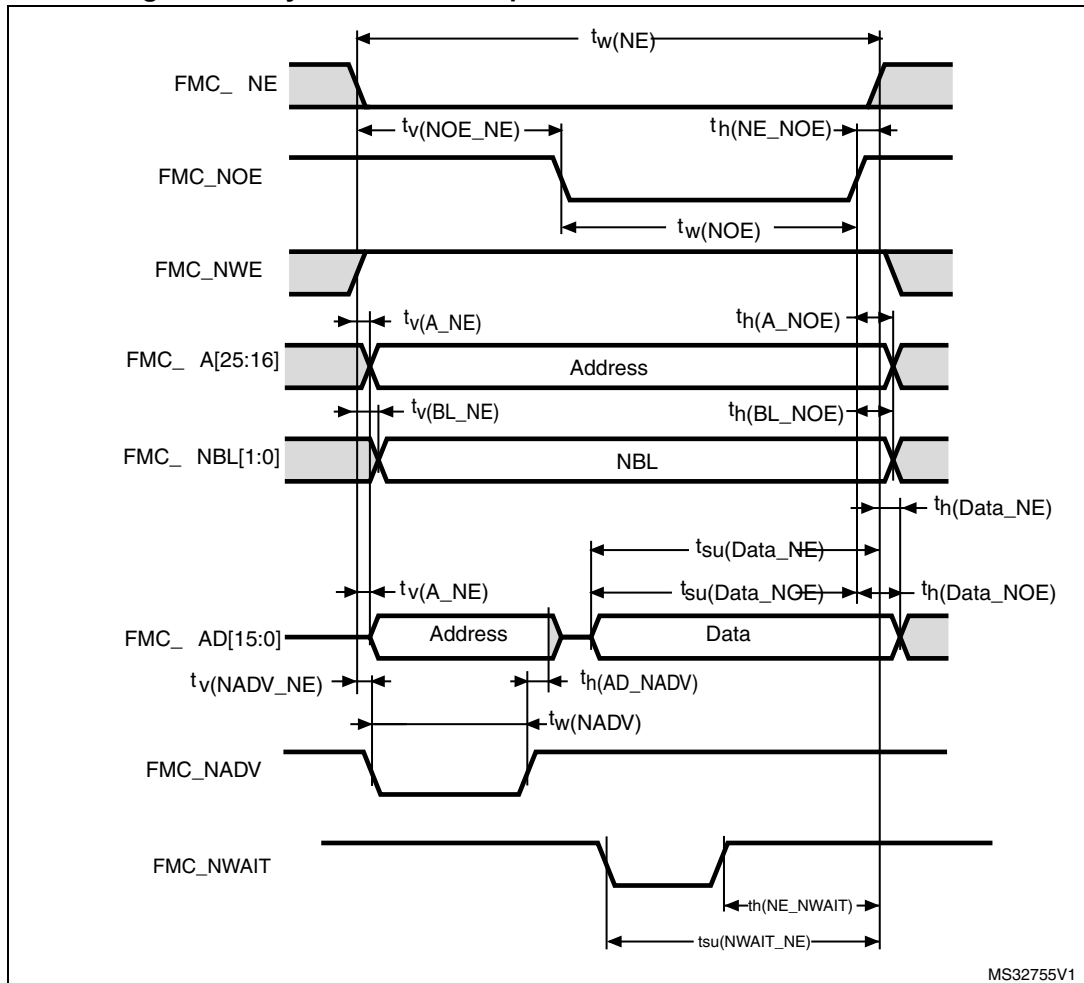

Table 93. Asynchronous multiplexed PSRAM/NOR read timings⁽¹⁾

Symbol	Parameter	Min	Max	Unit
$t_{w(NE)}$	FMC_NE low time	$3T_{HCLK} - 1$	$3T_{HCLK} + 0.5$	ns
$t_{v(NOE_NE)}$	FMC_NEx low to FMC_NOE low	$2T_{HCLK} - 0.5$	$2T_{HCLK}$	
$t_{tw(NOE)}$	FMC_NOE low time	$T_{HCLK} - 1$	$T_{HCLK} + 1$	
$t_{h(NE_NOE)}$	FMC_NOE high to FMC_NE high hold time	1	-	
$t_{v(A_NE)}$	FMC_NEx low to FMC_A valid	-	2	
$t_{v(NADV_NE)}$	FMC_NEx low to FMC_NADV low	0	2	
$t_{w(NADV)}$	FMC_NADV low time	$T_{HCLK} - 0.5$	$T_{HCLK} + 0.5$	
$t_{h(AD_NADV)}$	FMC_AD(address) valid hold time after FMC_NADV high	0	-	
$t_{h(A_NOE)}$	Address hold time after FMC_NOE high	$T_{HCLK} - 0.5$	-	
$t_{h(BL_NOE)}$	FMC_BL time after FMC_NOE high	0	-	
$t_{v(BL_NE)}$	FMC_NEx low to FMC_BL valid	-	2	
$t_{su(Data_NE)}$	Data to FMC_NEx high setup time	$T_{HCLK} + 1.5$	-	
$t_{su(Data_NOE)}$	Data to FMC_NOE high setup time	$T_{HCLK} + 1$	-	
$t_{h(Data_NE)}$	Data hold time after FMC_NEx high	0	-	
$t_{h(Data_NOE)}$	Data hold time after FMC_NOE high	0	-	

1. Based on test during characterization.

Table 94. Asynchronous multiplexed PSRAM/NOR read-NWAIT timings⁽¹⁾

Symbol	Parameter	Min	Max	Unit
$t_{w(NE)}$	FMC_NE low time	$8T_{HCLK} + 0.5$	$8T_{HCLK} + 2$	ns
$t_{w(NOE)}$	FMC_NWE low time	$5T_{HCLK} - 1$	$5T_{HCLK} + 1.5$	
$t_{su(NWAIT_NE)}$	FMC_NWAIT valid before FMC_NEx high	$5T_{HCLK} + 1.5$	-	
$t_{h(NE_NWAIT)}$	FMC_NEx hold time after FMC_NWAIT invalid	$4T_{HCLK} + 1$	-	

1. Based on test during characterization.

Figure 60. Asynchronous multiplexed PSRAM/NOR write waveforms

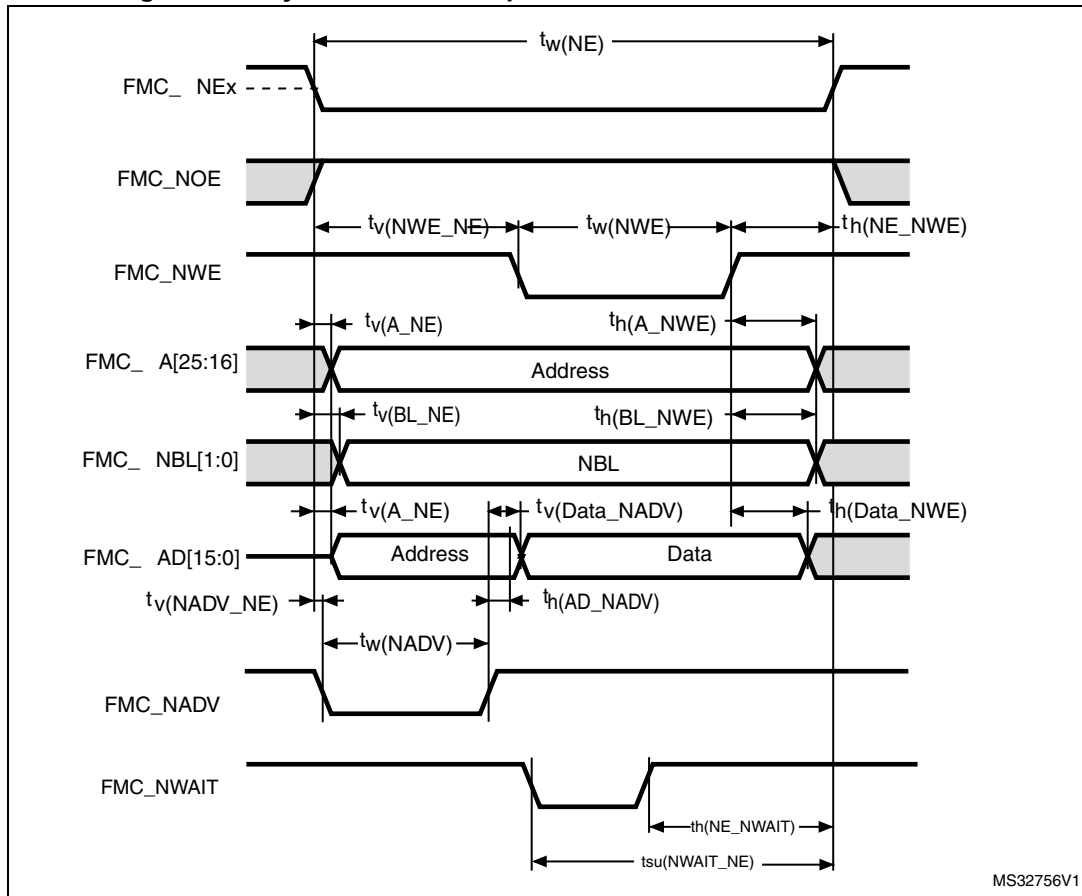

MS32756V1

Table 95. Asynchronous multiplexed PSRAM/NOR write timings⁽¹⁾

Symbol	Parameter	Min	Max	Unit
$t_w(NE)$	FMC_NE low time	$4T_{HCLK}$	$4T_{HCLK}+0.5$	ns
$t_v(NWE_NE)$	FMC_NEx low to FMC_NWE low	$T_{HCLK} - 1$	$T_{HCLK}+0.5$	
$t_w(NWE)$	FMC_NWE low time	$2T_{HCLK}$	$2T_{HCLK}+0.5$	
$t_h(NE_NWE)$	FMC_NWE high to FMC_NE high hold time	T_{HCLK}	-	
$t_v(A_NE)$	FMC_NEx low to FMC_A valid	-	0	
$t_v(NADV_NE)$	FMC_NEx low to FMC_NADV low	0.5	1	
$t_w(NADV)$	FMC_NADV low time	$T_{HCLK} - 0.5$	$T_{HCLK}+ 0.5$	
$t_h(AD_NADV)$	FMC_AD (address) valid hold time after FMC_NADV high	$T_{HCLK} - 2$	-	
$t_h(A_NWE)$	Address hold time after FMC_NWE high	T_{HCLK}	-	
$t_h(BL_NWE)$	FMC_BL hold time after FMC_NWE high	$T_{HCLK} - 2$	-	
$t_v(BL_NE)$	FMC_NEx low to FMC_BL valid	-	2	
$t_v(Data_NADV)$	FMC_NADV high to Data valid	-	$T_{HCLK} +1.5$	
$t_h(Data_NWE)$	Data hold time after FMC_NWE high	$T_{HCLK} +0.5$	-	

1. Based on test during characterization.

Table 96. Asynchronous multiplexed PSRAM/NOR write-NWAIT timings⁽¹⁾

Symbol	Parameter	Min	Max	Unit
$t_{w(NE)}$	FMC_NE low time	$9T_{HCLK}$	$9T_{HCLK}+0.5$	ns
$t_{w(NWE)}$	FMC_NWE low time	$7T_{HCLK}$	$7T_{HCLK}+2$	
$t_{su(NWAIT_NE)}$	FMC_NWAIT valid before FMC_NEx high	$6T_{HCLK}+1.5$	-	
$t_{h(NE_NWAIT)}$	FMC_NEx hold time after FMC_NWAIT invalid	$4T_{HCLK}-1$	-	

1. Based on test during characterization.

Synchronous waveforms and timings

Figures 61 through 64 represent synchronous waveforms and Table 97 through Table 100 provide the corresponding timings. The results shown in these tables are obtained with the following FMC configuration:

- BurstAccessMode = FMC_BurstAccessMode_Enable;
- MemoryType = FMC_MemoryType_CRAM;
- WriteBurst = FMC_WriteBurst_Enable;
- CLKDivision = 1;
- DataLatency = 1 for NOR Flash; DataLatency = 0 for PSRAM
- C_L = 30 pF on data and address lines. C_L = 10 pF on FMC_CLK unless otherwise specified.

In all timing tables, the T_{HCLK} is the HCLK clock period:

- For $2.7 V \leq V_{DD} \leq 3.6 V$, maximum FMC_CLK = 90 MHz at C_L = 30 pF (on FMC_CLK).
- For $1.71 V \leq V_{DD} < 1.9 V$, maximum FMC_CLK = 60 MHz at C_L = 10 pF (on FMC_CLK).

Figure 61. Synchronous multiplexed NOR/PSRAM read timings

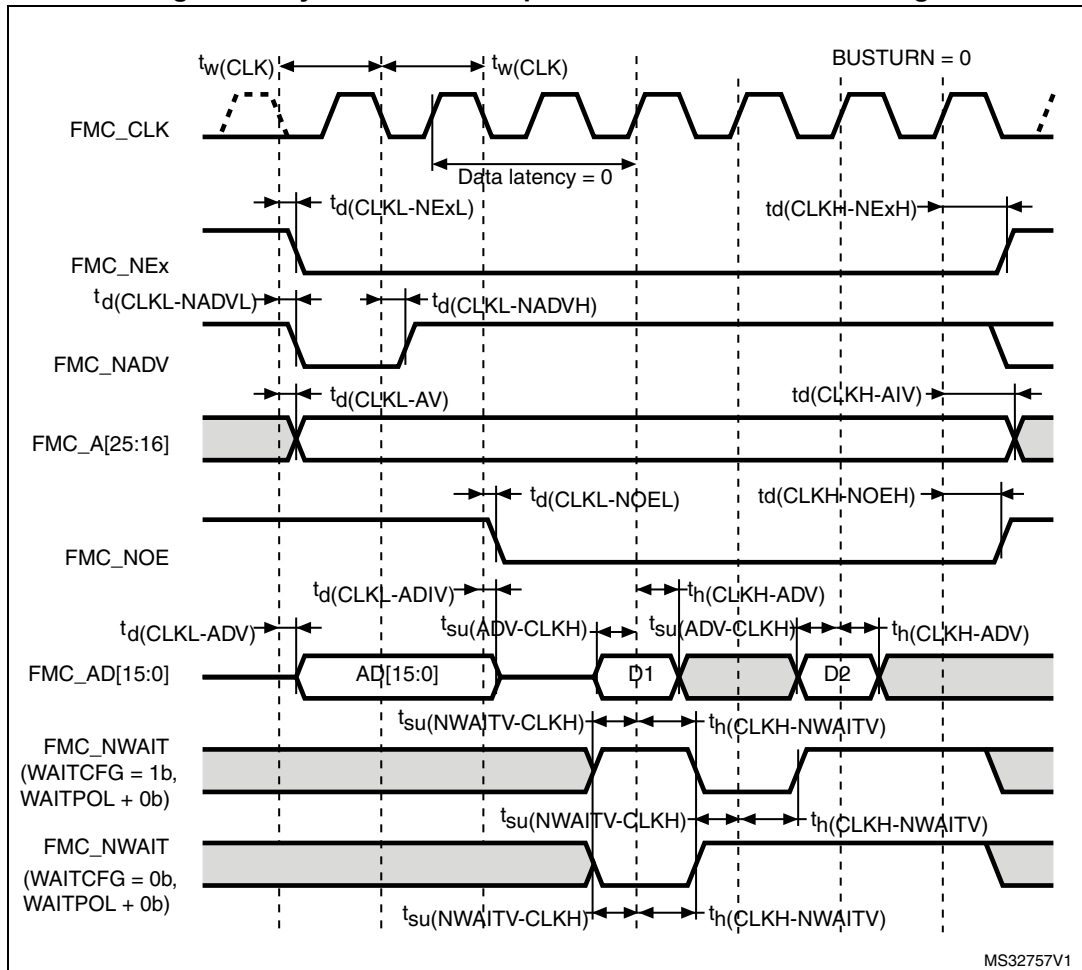

Table 97. Synchronous multiplexed NOR/PSRAM read timings⁽¹⁾

Symbol	Parameter	Min	Max	Unit
$t_{w(CLK)}$	FMC_CLK period	$2T_{HCLK} - 1$	-	ns
$t_{d(CLKL-NExL)}$	FMC_CLK low to FMC_NEx low (x=0..2)	-	0	
$t_{d(CLKH-NExH)}$	FMC_CLK high to FMC_NEx high (x= 0...2)	T_{HCLK}	-	
$t_{d(CLKL-NADVl)}$	FMC_CLK low to FMC_NADV low	-	0	
$t_{d(CLKL-NADVh)}$	FMC_CLK low to FMC_NADV high	0	-	
$t_{d(CLKL-AV)}$	FMC_CLK low to FMC_Ax valid (x=16...25)	-	0	
$t_{d(CLKH-AIV)}$	FMC_CLK high to FMC_Ax invalid (x=16...25)	0	-	
$t_{d(CLKL-NOEL)}$	FMC_CLK low to FMC_NOE low	-	$T_{HCLK}+0.5$	
$t_{d(CLKH-NOEH)}$	FMC_CLK high to FMC_NOE high	$T_{HCLK} - 0.5$	-	
$t_{d(CLKL-ADV)}$	FMC_CLK low to FMC_AD[15:0] valid	-	0.5	
$t_{d(CLKL-ADIV)}$	FMC_CLK low to FMC_AD[15:0] invalid	0	-	
$t_{su(ADV-CLKH)}$	FMC_A/D[15:0] valid data before FMC_CLK high	5	-	
$t_h(CLKH-ADV)$	FMC_A/D[15:0] valid data after FMC_CLK high	0	-	
$t_{su(NWAIT-CLKH)}$	FMC_NWAIT valid before FMC_CLK high	4	-	
$t_h(CLKH-NWAIT)$	FMC_NWAIT valid after FMC_CLK high	0	-	

1. Based on test during characterization.

Figure 62. Synchronous multiplexed PSRAM write timings

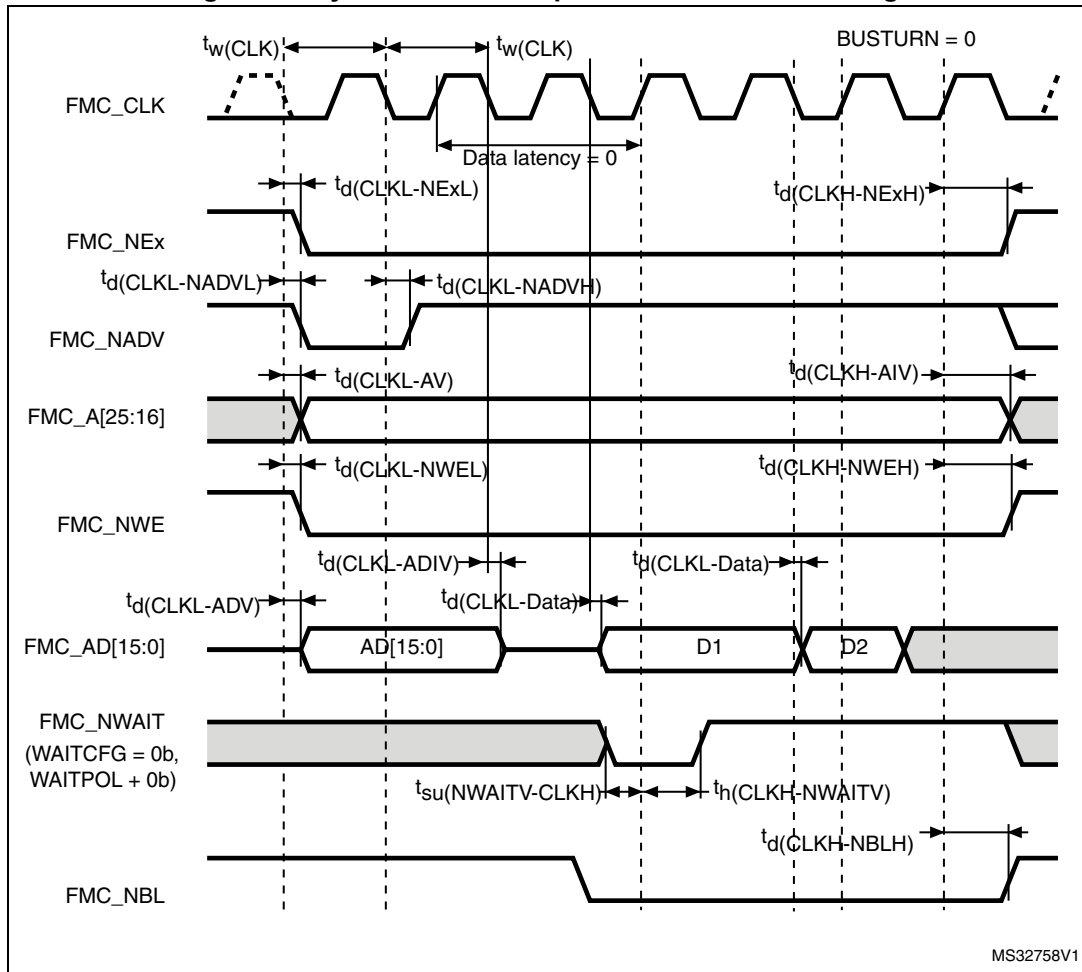
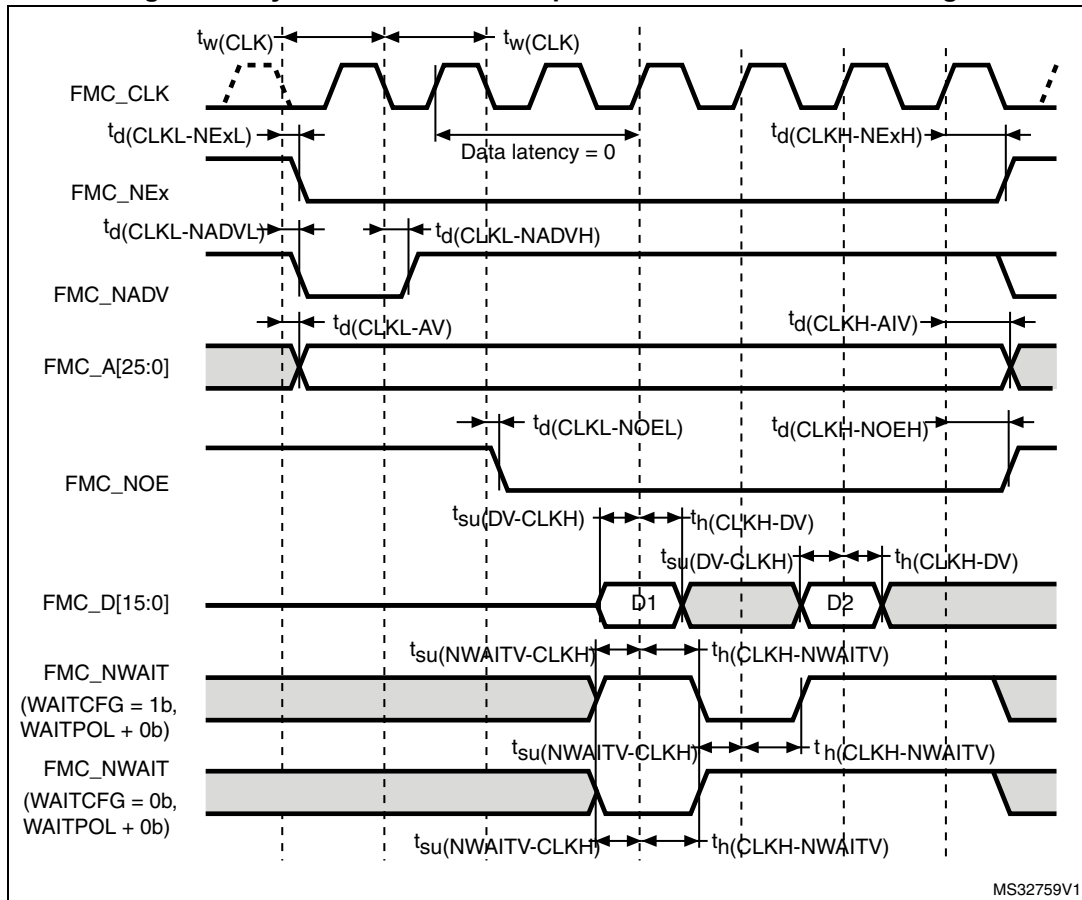

Table 98. Synchronous multiplexed PSRAM write timings⁽¹⁾

Symbol	Parameter	Min	Max	Unit
$t_{w(CLK)}$	FMC_CLK period, V_{DD} range= 2.7 to 3.6 V	$2T_{HCLK} - 1$	-	ns
$t_{d(CLKL-NExL)}$	FMC_CLK low to FMC_NEx low (x=0...2)	-	1.5	
$t_{d(CLKH-NExH)}$	FMC_CLK high to FMC_NEx high (x= 0...2)	T_{HCLK}	-	
$t_{d(CLKL-NADVl)}$	FMC_CLK low to FMC_NADV low	-	0	
$t_{d(CLKL-NADVh)}$	FMC_CLK low to FMC_NADV high	0	-	
$t_{d(CLKL-AV)}$	FMC_CLK low to FMC_Ax valid (x=16...25)	-	0	
$t_{d(CLKH-AIV)}$	FMC_CLK high to FMC_Ax invalid (x=16...25)	T_{HCLK}	-	
$t_{d(CLKL-NWEL)}$	FMC_CLK low to FMC_NWE low	-	0	
$t_{d(CLKH-NWEH)}$	FMC_CLK high to FMC_NWE high	$T_{HCLK} - 0.5$	-	
$t_{d(CLKL-ADV)}$	FMC_CLK low to FMC_AD[15:0] valid	-	3	
$t_{d(CLKL-ADIV)}$	FMC_CLK low to FMC_AD[15:0] invalid	0	-	
$t_{d(CLKL-DATA)}$	FMC_A/D[15:0] valid data after FMC_CLK low	-	3	
$t_{d(CLKL-NBLL)}$	FMC_CLK low to FMC_NBL low	0	-	
$t_{d(CLKH-NBLH)}$	FMC_CLK high to FMC_NBL high	$T_{HCLK} - 0.5$	-	
$t_{su(NWAIT-CLKH)}$	FMC_NWAIT valid before FMC_CLK high	4	-	
$t_h(CLKH-NWAIT)$	FMC_NWAIT valid after FMC_CLK high	0	-	

1. Based on test during characterization.

Figure 63. Synchronous non-multiplexed NOR/PSRAM read timings



MS32759V1

Table 99. Synchronous non-multiplexed NOR/PSRAM read timings⁽¹⁾

Symbol	Parameter	Min	Max	Unit
$t_w(\text{CLK})$	FMC_CLK period	$2T_{\text{HCLK}} - 1$	-	ns
$t_{\text{d}}(\text{CLKL-NExL})$	FMC_CLK low to FMC_NEx low (x=0...2)	-	0.5	
$t_{\text{d}}(\text{CLKH-NExH})$	FMC_CLK high to FMC_NEx high (x=0...2)	T_{HCLK}	-	
$t_{\text{d}}(\text{CLKL-NADV})$	FMC_CLK low to FMC_NADV low	-	0	
$t_{\text{d}}(\text{CLKL-NADVH})$	FMC_CLK low to FMC_NADV high	0	-	
$t_{\text{d}}(\text{CLKL-AV})$	FMC_CLK low to FMC_Ax valid (x=16...25)	-	0	
$t_{\text{d}}(\text{CLKH-AIV})$	FMC_CLK high to FMC_Ax invalid (x=16...25)	$T_{\text{HCLK}} - 0.5$	-	
$t_{\text{d}}(\text{CLKL-NOEL})$	FMC_CLK low to FMC_NOE low	-	$T_{\text{HCLK}} + 2$	
$t_{\text{d}}(\text{CLKH-NOEH})$	FMC_CLK high to FMC_NOE high	$T_{\text{HCLK}} - 0.5$	-	
$t_{\text{su}}(\text{DV-CLKH})$	FMC_D[15:0] valid data before FMC_CLK high	5	-	
$t_{\text{h}}(\text{CLKH-DV})$	FMC_D[15:0] valid data after FMC_CLK high	0	-	
$t_{\text{su}}(\text{NWAITV-CLKH})$	FMC_NWAIT valid before FMC_CLK high	4	-	
$t_{\text{h}}(\text{CLKH-NWAITV})$	FMC_NWAIT valid after FMC_CLK high	0	-	

1. Based on test during characterization.

Figure 64. Synchronous non-multiplexed PSRAM write timings

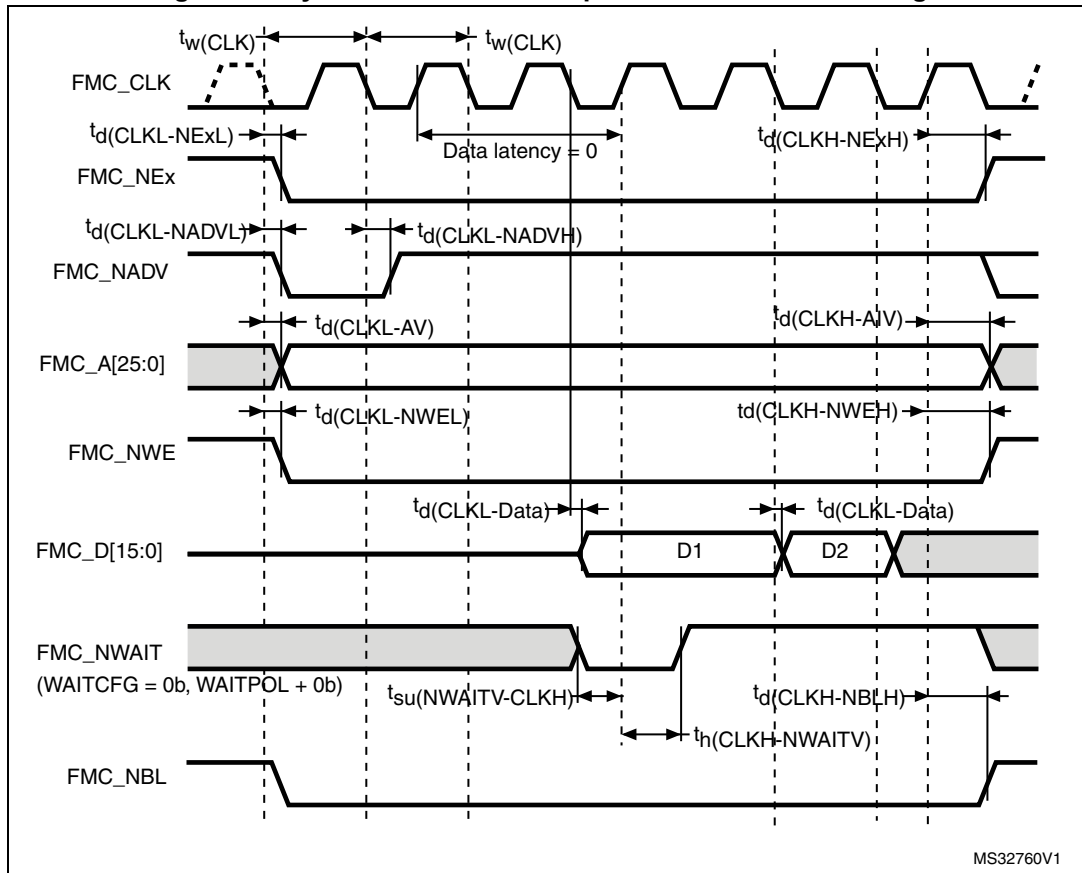

MS32760V1

Table 100. Synchronous non-multiplexed PSRAM write timings⁽¹⁾

Symbol	Parameter	Min	Max	Unit
$t_{(CLK)}$	FMC_CLK period	$2T_{HCLK} - 1$	-	
$t_{d(CLKL-NExL)}$	FMC_CLK low to FMC_NEx low (x=0...2)	-	0.5	ns
$t_{d(CLKH-NExH)}$	FMC_CLK high to FMC_NEx high (x= 0...2)	T_{HCLK}	-	
$t_{d(CLKL-NADVl)}$	FMC_CLK low to FMC_NADV low	-	0	
$t_{d(CLKL-NADVh)}$	FMC_CLK low to FMC_NADV high	0	-	
$t_{d(CLKL-AV)}$	FMC_CLK low to FMC_Ax valid (x=16...25)	-	0	
$t_{d(CLKH-AIV)}$	FMC_CLK high to FMC_Ax invalid (x=16...25)	0	-	
$t_{d(CLKL-NWEL)}$	FMC_CLK low to FMC_NWE low	-	0	
$t_{d(CLKH-NWEH)}$	FMC_CLK high to FMC_NWE high	$T_{HCLK} - 0.5$	-	
$t_{d(CLKL-Data)}$	FMC_D[15:0] valid data after FMC_CLK low	-	2.5	
$t_{d(CLKL-NBLL)}$	FMC_CLK low to FMC_NBL low	0	-	
$t_{d(CLKH-NBLH)}$	FMC_CLK high to FMC_NBL high	$T_{HCLK} - 0.5$	-	
$t_{su(NWAITV-CLKH)}$	FMC_NWAIT valid before FMC_CLK high	4	-	
$t_{h(CLKH-NWAITV)}$	FMC_NWAIT valid after FMC_CLK high	0	-	

1. Based on test during characterization.

NAND controller waveforms and timings

Figures 65 through 68 represent synchronous waveforms, and Table 101 and Table 102 provide the corresponding timings. The results shown in this table are obtained with the following FMC configuration:

- COM.FMC_SetupTime = 0x01;
- COM.FMC_WaitSetupTime = 0x03;
- COM.FMC_HoldSetupTime = 0x02;
- COM.FMC_HiZSetupTime = 0x01;
- ATT.FMC_SetupTime = 0x01;
- ATT.FMC_WaitSetupTime = 0x03;
- ATT.FMC_HoldSetupTime = 0x02;
- ATT.FMC_HiZSetupTime = 0x01;
- Bank = FMC_Bank_NAND;
- MemoryDataWidth = FMC_MemoryDataWidth_16b;
- ECC = FMC_ECC_Enable;
- ECCPageSize = FMC_ECCPageSize_512Bytes;
- TCLRSetupTime = 0;
- TARSetupTime = 0;
- Capacitive load $C_L = 30$ pF.

In all timing tables, the T_{HCLK} is the HCLK clock period.

Figure 65. NAND controller waveforms for read access

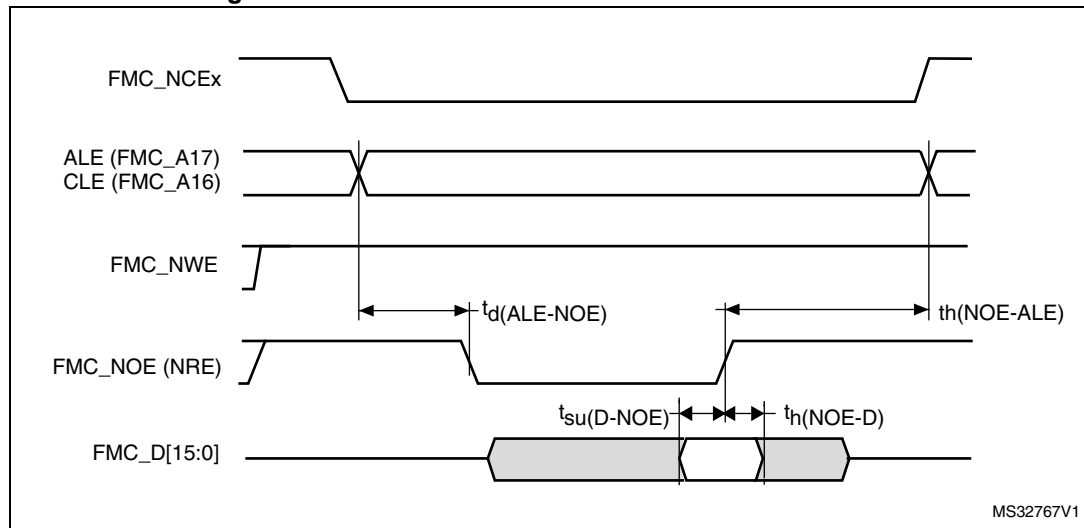

Figure 66. NAND controller waveforms for write access

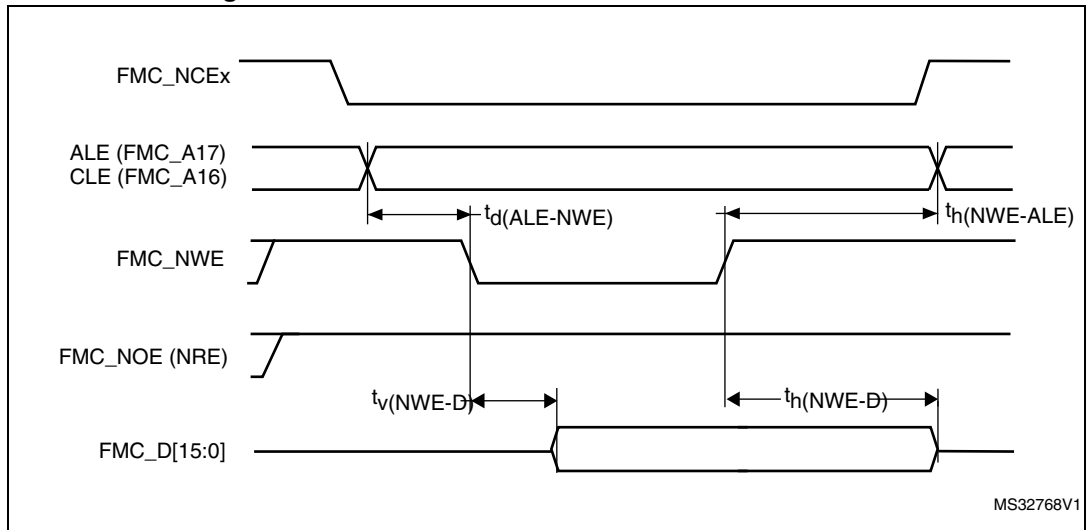

Figure 67. NAND controller waveforms for common memory read access

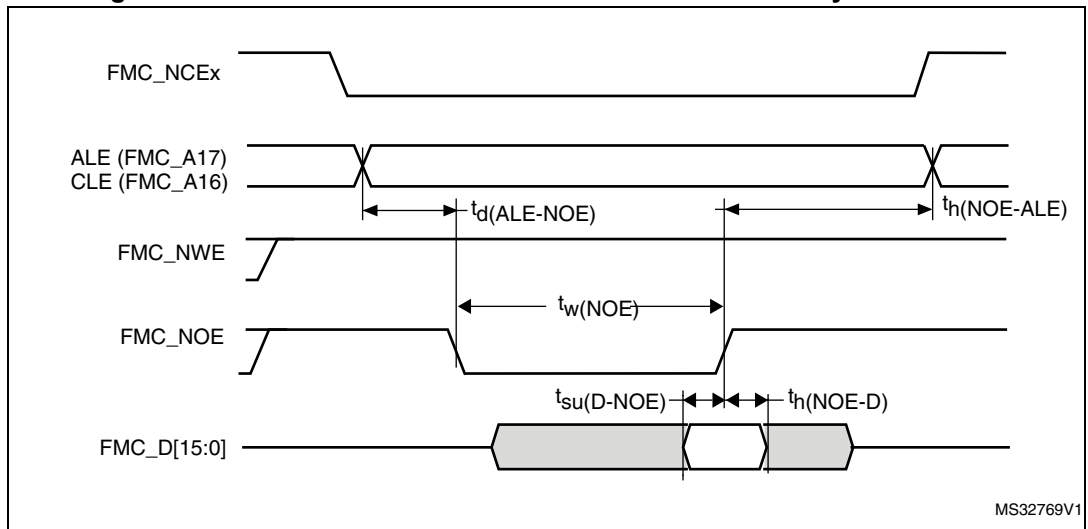
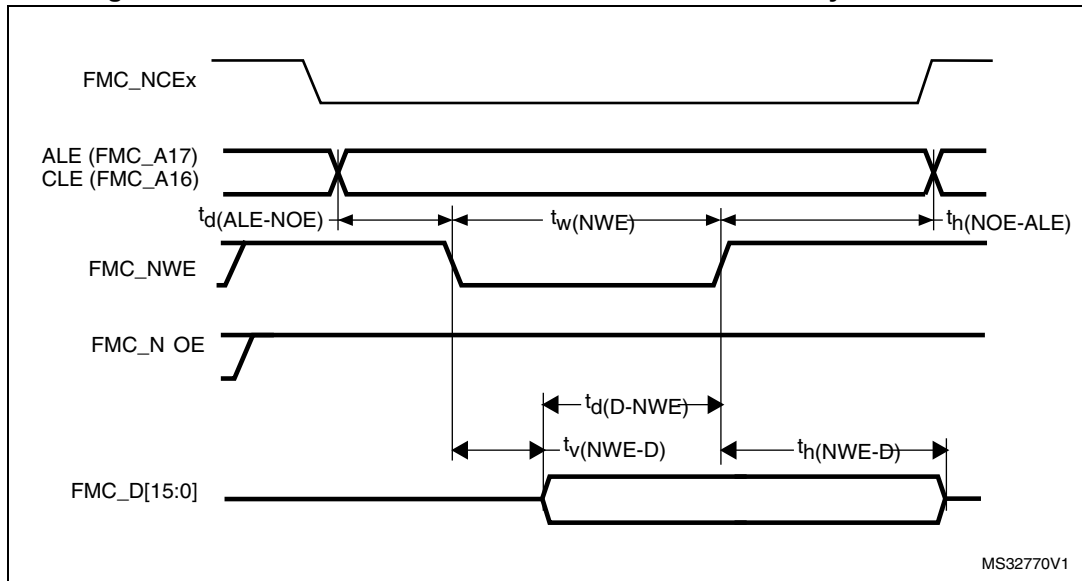

Figure 68. NAND controller waveforms for common memory write access



MS32770V1

Table 101. Switching characteristics for NAND Flash read cycles

Symbol	Parameter	Min	Max	Unit
$t_w(\text{NOE})$	FMC_NOE low width	$4T_{\text{HCLK}} - 0.5$	$4T_{\text{HCLK}} + 0.5$	ns
$t_{\text{su}}(\text{D-NOE})$	FMC_D[15-0] valid data before FMC_NOE high	9	-	
$t_h(\text{NOE-D})$	FMC_D[15-0] valid data after FMC_NOE high	0	-	
$t_d(\text{ALE-NOE})$	FMC_ALE valid before FMC_NOE low	-	$3T_{\text{HCLK}} - 0.5$	
$t_h(\text{NOE-ALE})$	FMC_NWE high to FMC_ALE invalid	$3T_{\text{HCLK}} - 2$	-	

Table 102. Switching characteristics for NAND Flash write cycles

Symbol	Parameter	Min	Max	Unit
$t_w(\text{NWE})$	FMC_NWE low width	$4T_{\text{HCLK}}$	$4T_{\text{HCLK}} + 1$	ns
$t_v(\text{NWE-D})$	FMC_NWE low to FMC_D[15-0] valid	0	-	
$t_h(\text{NWE-D})$	FMC_NWE high to FMC_D[15-0] invalid	$3T_{\text{HCLK}} - 1$	-	
$t_d(\text{D-NWE})$	FMC_D[15-0] valid before FMC_NWE high	$5T_{\text{HCLK}} - 3$	-	
$t_d(\text{ALE-NWE})$	FMC_ALE valid before FMC_NWE low	-	$3T_{\text{HCLK}} - 0.5$	
$t_h(\text{NWE-ALE})$	FMC_NWE high to FMC_ALE invalid	$3T_{\text{HCLK}} - 1$	-	

SDRAM waveforms and timings

- $C_L = 30 \text{ pF}$ on data and address lines.
- $C_L = 10 \text{ pF}$ on FMC_SDCLK unless otherwise specified.

In all timing tables, the T_{HCLK} is the HCLK clock period.

- For $2.7\text{ V} \leq V_{DD} \leq 3.6\text{ V}$, maximum FMC_SDCLK = 90 MHz, at $C_L = 30\text{ pF}$ (on FMC_SDCLK).
- For $1.71\text{ V} \leq V_{DD} < 1.9\text{ V}$, maximum FMC_SDCLK = 75 MHz when CAS Latency = 3 and 60 MHz for CAS latency 1 or 2. $C_L = 10\text{ pF}$ (on FMC_SDCLK).

Figure 69. SDRAM read access waveforms (CL = 1)

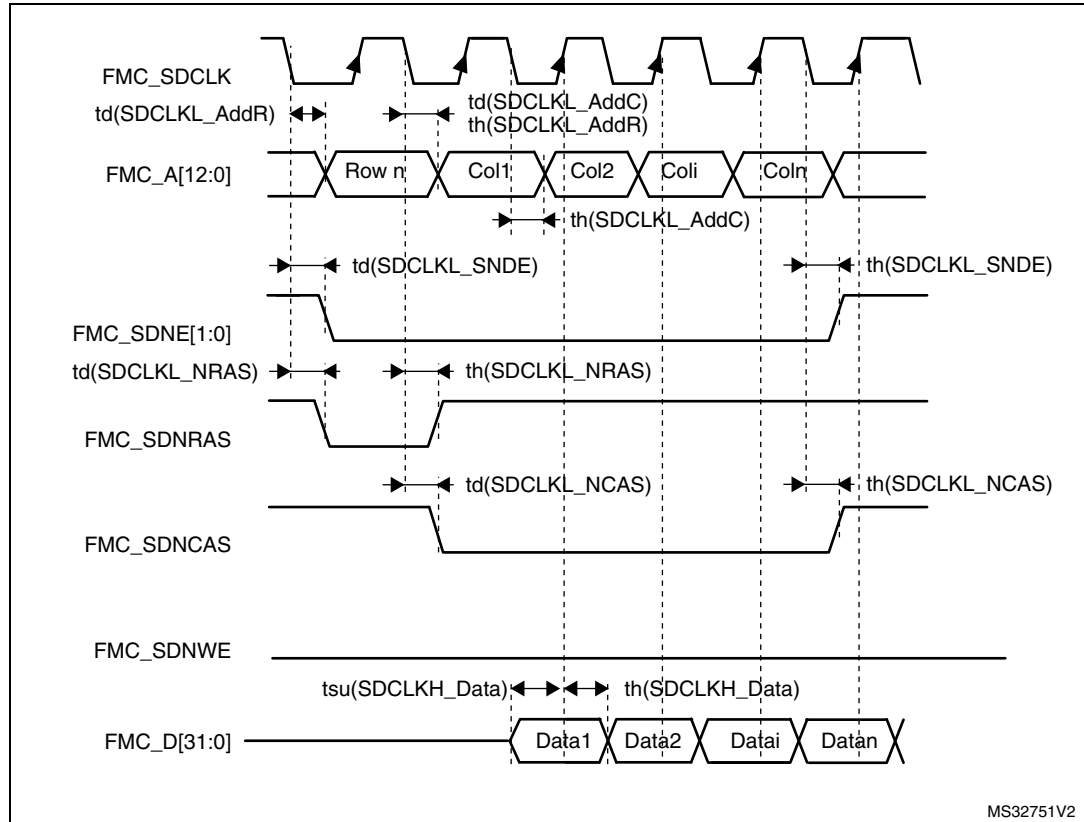

MS32751V2

Table 103. SDRAM read timings⁽¹⁾

Symbol	Parameter	Min	Max	Unit
$t_w(\text{SDCLK})$	FMC_SDCLK period	$2T_{HCLK} - 0.5$	$2T_{HCLK} + 0.5$	ns
$t_{su}(\text{SDCLKH_Data})$	Data input setup time	2	-	
$t_h(\text{SDCLKH_Data})$	Data input hold time	0	-	
$t_d(\text{SDCLKL_Add})$	Address valid time	-	1.5	
$t_d(\text{SDCLKL_SDNE})$	Chip select valid time	-	0.5	
$t_h(\text{SDCLKL_SDNE})$	Chip select hold time	0	-	
$t_d(\text{SDCLKL_SDNRAS})$	SDNRAS valid time	-	0.5	
$t_h(\text{SDCLKL_SDNRAS})$	SDNRAS hold time	0	-	
$t_d(\text{SDCLKL_SDNCAS})$	SDNCAS valid time	-	0.5	
$t_h(\text{SDCLKL_SDNCAS})$	SDNCAS hold time	0	-	

1. Guaranteed based on test during characterization.

Table 104. LPDDR SDRAM read timings⁽¹⁾

Symbol	Parameter	Min	Max	Unit
$t_{W(SDCLK)}$	FMC_SDCLK period	$2T_{HCLK} - 0.5$	$2T_{HCLK} + 0.5$	ns
$t_{su(SDCLKH_Data)}$	Data input setup time	2.5	-	
$t_{h(SDCLKH_Data)}$	Data input hold time	0	-	
$t_d(SDCLKL_Add)$	Address valid time	-	1	
$t_d(SDCLKL_SDNE)$	Chip select valid time	-	1	
$t_h(SDCLKL_SDNE)$	Chip select hold time	1	-	
$t_d(SDCLKL_SDNRAS)$	SDNRAS valid time	-	1	
$t_h(SDCLKL_SDNRAS)$	SDNRAS hold time	1	-	
$t_d(SDCLKL_SDNCAS)$	SDNCAS valid time	-	1	
$t_h(SDCLKL_SDNCAS)$	SDNCAS hold time	1	-	

1. Guaranteed based on test during characterization.

Figure 70. SDRAM write access waveforms

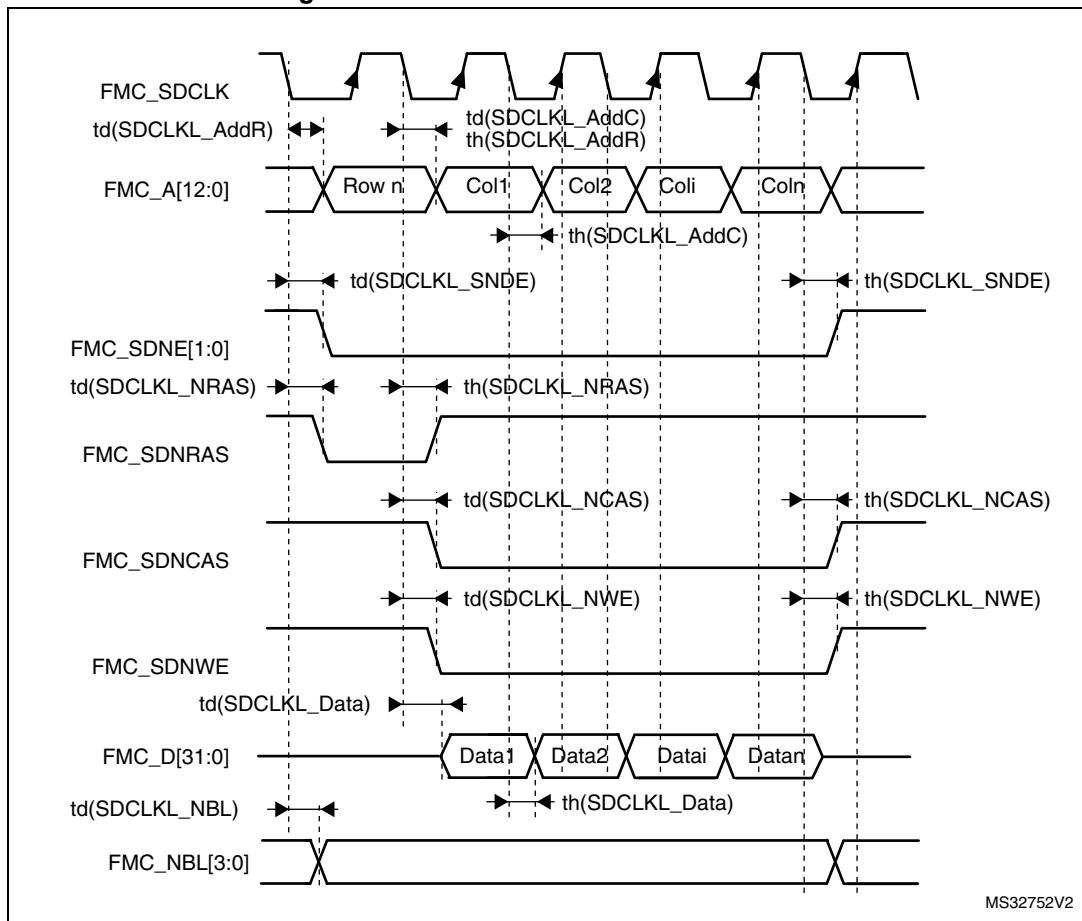

Table 105. SDRAM write timings⁽¹⁾

Symbol	Parameter	Min	Max	Unit
$t_w(\text{SDCLK})$	FMC_SDCLK period	$2T_{\text{HCLK}} - 0.5$	$2T_{\text{HCLK}}+0.5$	ns
$t_d(\text{SDCLKL_Data})$	Data output valid time	-	2.5	
$t_h(\text{SDCLKL_Data})$	Data output hold time	3.5	-	
$t_d(\text{SDCLKL_Add})$	Address valid time	-	1.5	
$t_d(\text{SDCLKL_SDNWE})$	SDNWE valid time	-	1	
$t_h(\text{SDCLKL_SDNWE})$	SDNWE hold time	0	-	
$t_d(\text{SDCLKL_SDNE})$	Chip select valid time	-	0.5	
$t_h(\text{SDCLKL_SDNE})$	Chip select hold time	0	-	
$t_d(\text{SDCLKL_SDNRAS})$	SDNRAS valid time	-	2	
$t_h(\text{SDCLKL_SDNRAS})$	SDNRAS hold time	0	-	
$t_d(\text{SDCLKL_SDNCAS})$	SDNCAS valid time	-	0.5	
$t_d(\text{SDCLKL_SDNCAS})$	SDNCAS hold time	0	-	
$t_d(\text{SDCLKL_NBL})$	NBL valid time	-	0.5	
$t_h(\text{SDCLKL_NBL})$	NBL output time	0	-	

1. Guaranteed based on test during characterization.

Table 106. LPSDR SDRAM write timings⁽¹⁾

Symbol	Parameter	Min	Max	Unit
$t_w(\text{SDCLK})$	FMC_SDCLK period	$2T_{\text{HCLK}} - 0.5$	$2T_{\text{HCLK}}+0.5$	ns
$t_d(\text{SDCLKL_Data})$	Data output valid time	-	5	
$t_h(\text{SDCLKL_Data})$	Data output hold time	2	-	
$t_d(\text{SDCLKL_Add})$	Address valid time	-	2.8	
$t_d(\text{SDCLKL-SDNWE})$	SDNWE valid time	-	2	
$t_h(\text{SDCLKL-SDNWE})$	SDNWE hold time	1	-	
$t_d(\text{SDCLKL-SDNE})$	Chip select valid time	-	1.5	
$t_h(\text{SDCLKL-SDNE})$	Chip select hold time	1	-	
$t_d(\text{SDCLKL-SDNRAS})$	SDNRAS valid time	-	1.5	
$t_h(\text{SDCLKL-SDNRAS})$	SDNRAS hold time	1.5	-	
$t_d(\text{SDCLKL-SDNCAS})$	SDNCAS valid time	-	1.5	
$t_d(\text{SDCLKL-SDNCAS})$	SDNCAS hold time	1.5	-	
$t_d(\text{SDCLKL_NBL})$	NBL valid time	-	1.5	
$t_h(\text{SDCLKL-NBL})$	NBL output time	1.5	-	

1. Guaranteed based on test during characterization.

5.3.30 Quad-SPI interface characteristics

Unless otherwise specified, the parameters given in [Table 107](#) and [Table 108](#) for Quad-SPI are derived from tests performed under the ambient temperature, f_{AHB} frequency and V_{DD} supply voltage conditions summarized in Table xx, with the following configuration:

- Output speed is set to $\text{OSPEEDRy}[1:0] = 11$
- Measurement points are done at CMOS levels: $0.5 V_{\text{DD}}$

Refer to [Section 5.3.20](#) for more details on the input/output alternate function characteristics.

Table 107. Quad-SPI characteristics in SDR mode⁽¹⁾

Symbol	Parameter	Test conditions	Min	Typ	Max	Unit
F_{ck} $1/t_{(\text{CK})}$	Quad-SPI clock frequency	$2.7 \text{ V} \leq V_{\text{DD}} \leq 3.6 \text{ V}, C_{\text{L}} = 20 \text{ pF}$	-	-	90	MHz
		$1.71 \text{ V} \leq V_{\text{DD}} \leq 3.6 \text{ V}, C_{\text{L}} = 15 \text{ pF}$	-	-	84	
$t_{\text{w(CKH)}}$	Quad-SPI clock high time	-	$t_{(\text{CK})}/2-1$	-	$t_{(\text{CK})}/2$	ns
$t_{\text{w(CKL)}}$	Quad-SPI clock low time	-	$t_{(\text{CK})}/2$	-	$t_{(\text{CK})}/2+1$	
$t_{\text{s(IN)}}$	Data input set-up time	-	0.5	-	-	
$t_{\text{h(IN)}}$	Data input hold time	-	3	-	-	
$t_{\text{v(OUT)}}$	Data output valid time	-	-	3	4	
$t_{\text{h(OUT)}}$	Data output hold time	-	2.5	-	-	

1. Guaranteed based on test during characterization.

Figure 71. Quad-SPI SDR timing diagram

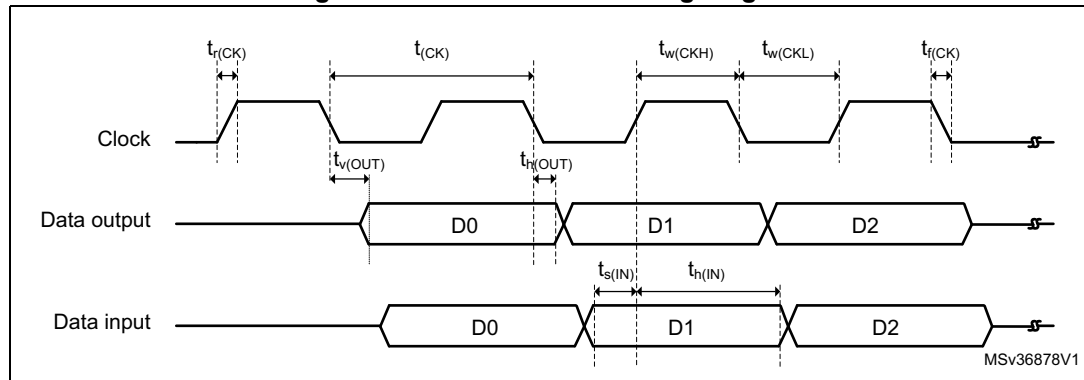
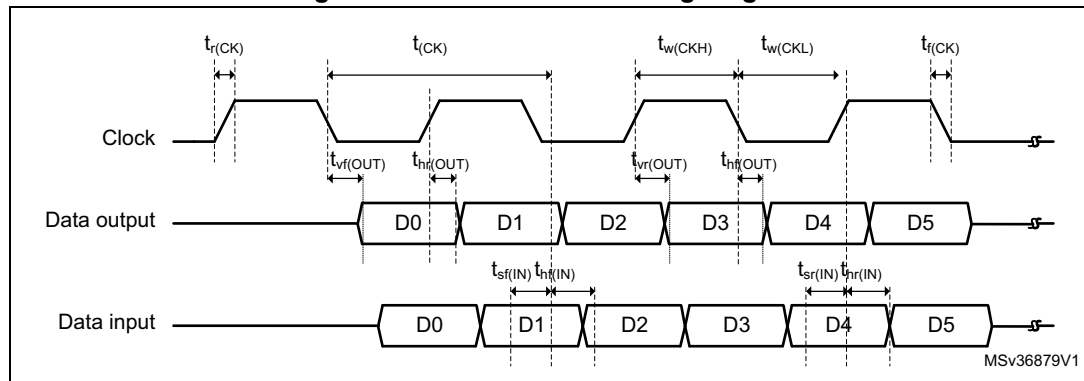

Table 108. Quad-SPI characteristics in DDR mode⁽¹⁾

Symbol	Parameter	Test conditions	Min	Typ	Max	Unit
F_{ck} $1/t_{(CK)}$	Quad-SPI clock frequency	$2.7\text{ V} \leq V_{DD} \leq 3.6\text{ V}$, $C_L = 20\text{ pF}$	-	-	80	MHz
		$1.71\text{ V} \leq V_{DD} \leq 3.6\text{ V}$, $C_L = 15\text{ pF}$	-	-	70	
$t_{w(CKH)}$	Quad-SPI clock high time	-	$t_{(CK)}/2-1$	-	$t_{(CK)}/2$	ns
$t_{w(CKL)}$	Quad-SPI clock low time	-	$t_{(CK)}/2$	-	$t_{(CK)}/2+1$	
$t_{sr(IN)}$ $t_{sf(IN)}$	Data input set-up time	$2.7\text{ V} \leq V_{DD} \leq 3.6\text{ V}$	2	-	-	
		$1.71\text{ V} \leq V_{DD} \leq 3.6\text{ V}$	0.5	-	-	
$t_{hr(IN)}$ $t_{hf(IN)}$	Data input hold time	$2.7\text{ V} \leq V_{DD} \leq 3.6\text{ V}$	3	-	-	
		$1.71\text{ V} \leq V_{DD} \leq 3.6\text{ V}$	4.5	-	-	
$t_{vr(OUT)}$ $t_{vf(OUT)}$	Data output valid time	DHHC=0	-	8	10.5	
		DHHC=1 Pres=1,2...	-	$T_{hclk}/2+2$	$T_{hclk}/2+2.5$	
$t_h(OUT)$ $t_f(OUT)$	Data output hold time	DHHC=0	7	-	-	
		DHHC=1 Pres=1,2...	$T_{hclk}/2+0.5$	-	-	

1. Guaranteed based on test during characterization.

Figure 72. Quad-SPI DDR timing diagram



5.3.31 Camera interface (DCMI) timing specifications

Unless otherwise specified, the parameters given in [Table 109](#) for DCMI are derived from tests performed under the ambient temperature, f_{HCLK} frequency and V_{DD} supply voltage summarized in [Table 17](#), with the following configuration:

- DCMI_PIXCLK polarity: falling
- DCMI_VSYNC and DCMI_HSYNC polarity: high
- Data formats: 14 bits
- Capacitive load $C = 30\text{ pF}$
- Measurement points are done at CMOS levels: $0.5 V_{DD}$

Table 109. DCMI characteristics⁽¹⁾

Symbol	Parameter	Min	Max	Unit
-	Frequency ratio DCMI_PIXCLK/f _{HCLK}	-	0.4	-
DCMI_PIXCLK	Pixel clock input	-	54	MHz
D _{Pixel}	Pixel clock input duty cycle	30	70	%
t _{su} (DATA)	Data input setup time	4	-	ns
t _h (DATA)	Data input hold time	1	-	
t _{su} (HSYNC) t _{su} (VSYNC)	DCMI_HSYNC/DCMI_VSYNC input setup time	3.5	-	
t _h (HSYNC) t _h (VSYNC)	DCMI_HSYNC/DCMI_VSYNC input hold time	0	-	

1. 1.Guaranteed based on test during characterization.

Figure 73. DCMI timing diagram

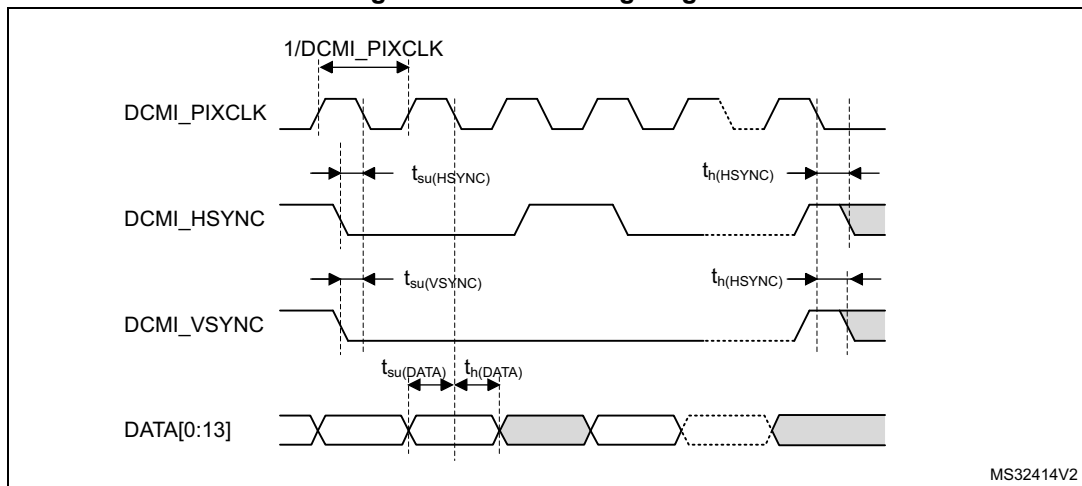

5.3.32 LCD-TFT controller (LTDC) characteristics

Unless otherwise specified, the parameters given in [Table 110](#) for LCD-TFT are derived from tests performed under the ambient temperature, f_{HCLK} frequency and VDD supply voltage summarized in [Table 17](#), with the following configuration:

- LCD_CLK polarity: high
- LCD_DE polarity: low
- LCD_VSYNC and LCD_HSYNC polarity: high
- Pixel formats: 24 bits
- Output speed is set to OSPEEDRy[1:0] = 11
- Capacitive load C_L = 30 pF
- Measurement points are done at CMOS levels: 0.5 V_{DD}

Table 110. LTDC characteristics⁽¹⁾

Symbol	Parameter	Min	Max	Unit
f _{CLK}	LTDC clock output frequency	-	65	MHz
D _{CLK}	LTDC clock output duty cycle	45	55	%
t _{w(CLKH)} t _{w(CLKL)}	Clock High time, low time	$t_{w(CLK)}/2 - 0.5$	$t_{w(CLK)}/2 + 0.5$	ns
t _{v(DATA)}	Data output valid time	-	1.5	
t _{h(DATA)}	Data output hold time	0	-	
t _{v(HSYNC)}	HSYNC/VSYNC/DE output valid time	-	0.5	
t _{v(VSYNC)}				
t _{v(DE)}				
t _{h(HSYNC)}	HSYNC/VSYNC/DE output hold time	0	-	
t _{h(VSYNC)}				
t _{h(DE)}				

1. Based on test during characterization.

Figure 74. LCD-TFT horizontal timing diagram

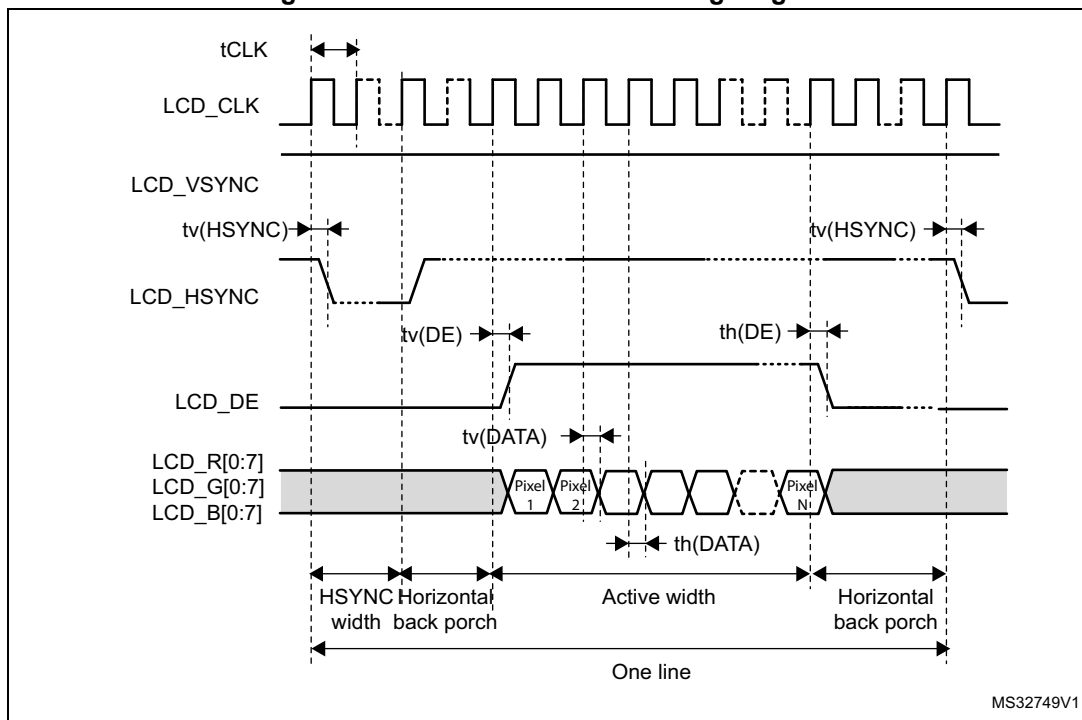

MS32749V1

Figure 75. LCD-TFT vertical timing diagram

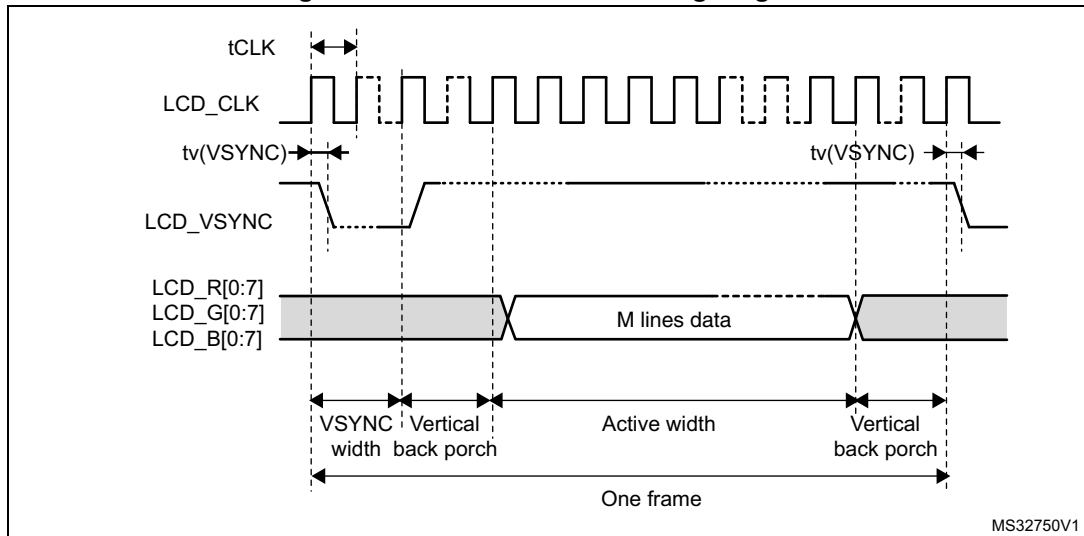

5.3.33 SD/SDIO MMC card host interface (SDIO) characteristics

Unless otherwise specified, the parameters given in [Table 111](#) for the SDIO/MMC interface are derived from tests performed under the ambient temperature, f_{PCLK2} frequency and V_{DD} supply voltage conditions summarized in [Table 17](#), with the following configuration:

- Output speed is set to $OSPEEDRy[1:0] = 11$
- Capacitive load $C = 30 \text{ pF}$
- Measurement points are done at CMOS levels: $0.5 V_{DD}$

Refer to [Section 5.3.20](#) for more details on the input/output characteristics.

Figure 76. SDIO high-speed mode

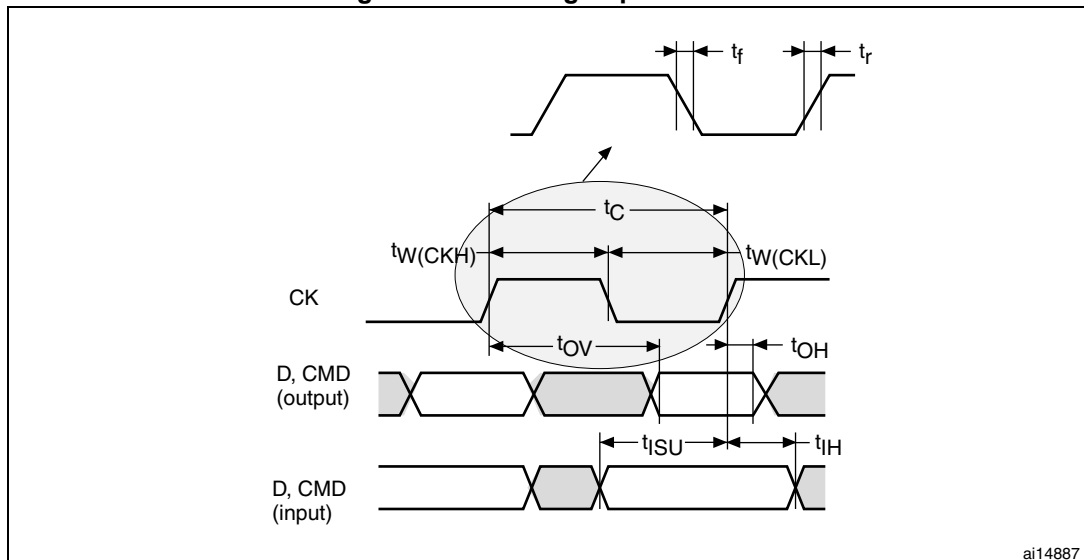
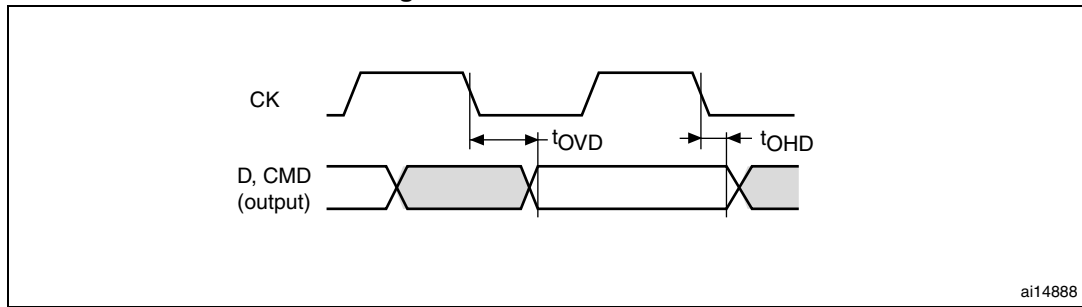

Figure 77. SD default mode



ai14888

Table 111. Dynamic characteristics: SD / MMC characteristics, $V_{DD} = 2.7$ to 3.6 V⁽¹⁾

Symbol	Parameter	Conditions	Min	Typ	Max	Unit
f_{PP}	Clock frequency in data transfer mode	-	0	-	50	MHz
-	SDIO_CK/fPCLK2 frequency ratio	-	-	-	8/3	-
$t_{W(CKL)}$	Clock low time	$f_{pp} = 50$ MHz	9.5	10.5	-	ns
$t_{W(CKH)}$	Clock high time		8.5	9.5	-	
CMD, D inputs (referenced to CK) in MMC and SD HS mode						
t_{ISU}	Input setup time HS	$f_{pp} = 50$ MHz	2.0	-	-	ns
t_{IH}	Input hold time HS		2.0	-	-	
CMD, D outputs (referenced to CK) in MMC and SD HS mode						
t_{OV}	Output valid time HS	$f_{pp} = 50$ MHz	-	13	13.5	ns
t_{OH}	Output hold time HS		12.5	-	-	
CMD, D inputs (referenced to CK) in SD default mode						
t_{ISUD}	Input setup time SD	$f_{pp} = 25$ MHz	2.0	-	-	ns
t_{IHD}	Input hold time SD		2.5	-	-	
CMD, D outputs (referenced to CK) in SD default mode						
t_{OVD}	Output valid default time SD	$f_{pp} = 25$ MHz	-	1.5	2.0	ns
t_{OHD}	Output hold default time SD		1.0	-	-	

1. Guaranteed based on test during characterization.

Table 112. Dynamic characteristics: SD / MMC characteristics, $V_{DD} = 1.71$ to 1.9 V⁽¹⁾⁽²⁾

Symbol	Parameter	Conditions	Min	Typ	Max	Unit
f_{PP}	Clock frequency in data transfer mode	-	0	-	50	MHz
-	SDIO_CK/fPCLK2 frequency ratio	-	-	-	8/3	-
$t_{W(CKL)}$	Clock low time	$f_{pp} = 50$ MHz	9.5	10.5	-	ns
$t_{W(CKH)}$	Clock high time		8.5	9.5	-	
CMD, D inputs (referenced to CK) in eMMC mode						
t_{ISU}	Input setup time HS	$f_{pp} = 50$ MHz	0.5	-	-	ns
t_{IH}	Input hold time HS		3.5	-	-	
CMD, D outputs (referenced to CK) in eMMC mode						
t_{OV}	Output valid time HS	$f_{pp} = 50$ MHz	-	13.5	14.5	ns
t_{OH}	Output hold time HS		13.0	-	-	

1. Guaranteed based on test during characterization.
2. $C_{load} = 20$ pF.

5.3.34 RTC characteristics

Table 113. RTC characteristics

Symbol	Parameter	Conditions	Min	Max
-	$f_{PCLK1}/RTCCLK$ frequency ratio	Any read/write operation from/to an RTC register	4	-

6 Package information

In order to meet environmental requirements, ST offers these devices in different grades of ECOPACK® packages, depending on their level of environmental compliance. ECOPACK® specifications, grade definitions and product status are available at: www.st.com. ECOPACK® is an ST trademark.

6.1 WLCSP168 package information

Figure 78. WLCSP168 - 168-pin, 4.891 x 5.692 mm, 0.4 mm pitch wafer level chip scale package outline

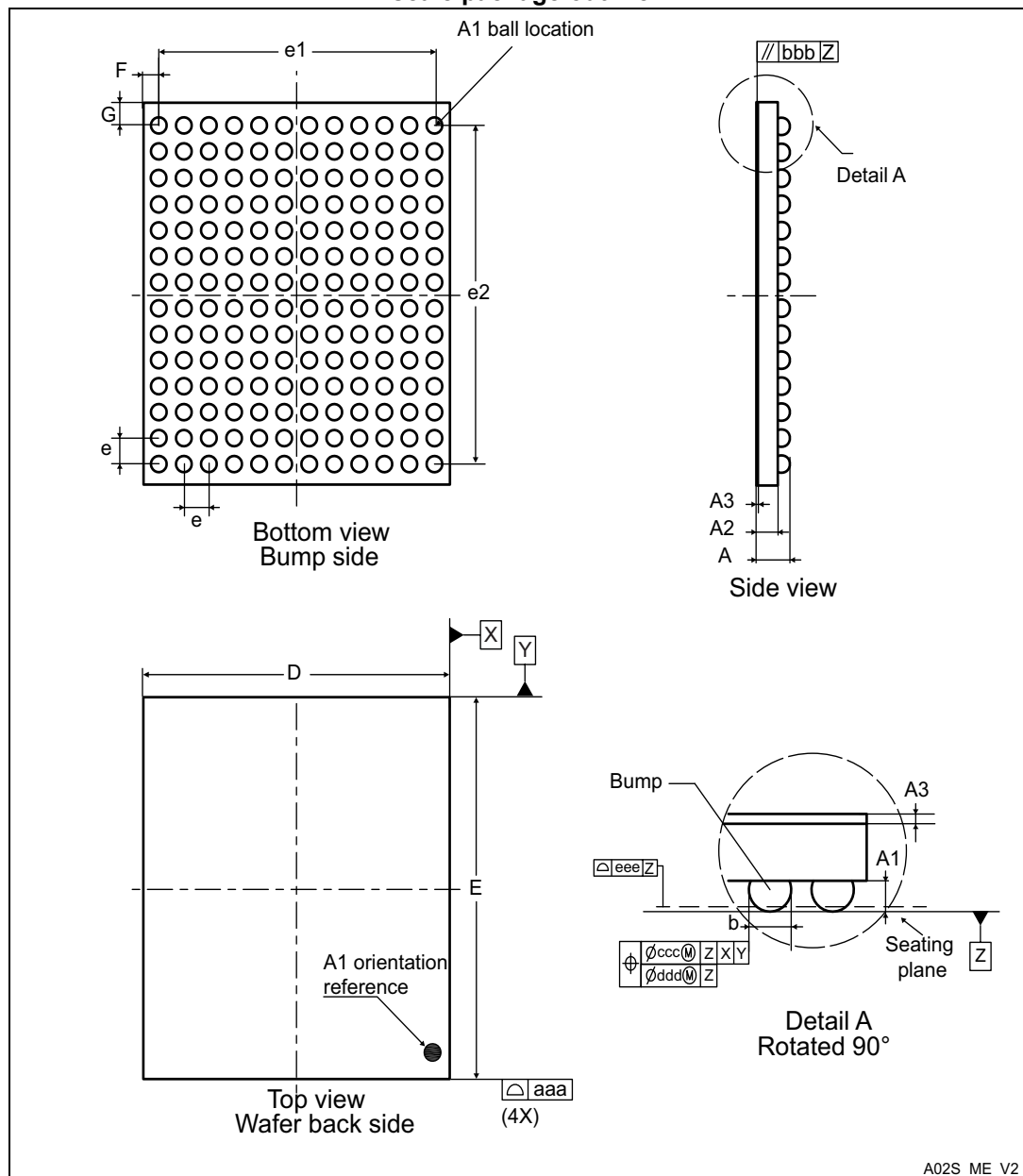

Table 114. WLCSP168 - 168-pin, 4.891 x 5.692 mm, 0.4 mm pitch wafer level chip scale package mechanical data

Symbol	millimeters			inches ⁽¹⁾		
	Min	Typ	Max	Min	Typ	Max
A	0.525	0.555	0.585	0.0207	0.0219	0.0230
A1	-	0.170	-	-	0.0067	-
A2	-	0.380	-	-	0.0150	-
A3 ⁽²⁾	-	0.025	-	-	0.0010	-
b ⁽³⁾	0.220	0.250	0.280	0.0087	0.0098	0.0110
D	4.856	4.891	4.926	0.1912	0.1926	0.1939
E	5.657	5.692	5.727	0.2227	0.2241	0.2255
e	-	0.400	-	-	0.0157	-
e1	-	4.400	-	-	0.1732	-
e2	-	5.200	-	-	0.2047	-
F	-	0.2455	-	-	0.0097	-
G	-	0.246	-	-	0.0097	-
aaa	-	-	0.100	-	-	0.0039
bbb	-	-	0.100	-	-	0.0039
ccc	-	-	0.100	-	-	0.0039
ddd	-	-	0.050	-	-	0.0020
eee	-	-	0.050	-	-	0.0020

1. Values in inches are converted from mm and rounded to 4 decimal digits.
2. Back side coating.
3. Dimension is measured at the maximum bump diameter parallel to primary datum Z.

6.2 UFBGA169 package information

Figure 79. UFBGA169 - 169-pin, 7 x 7 mm, 0.50 mm pitch, ultra fine pitch ball grid array package outline

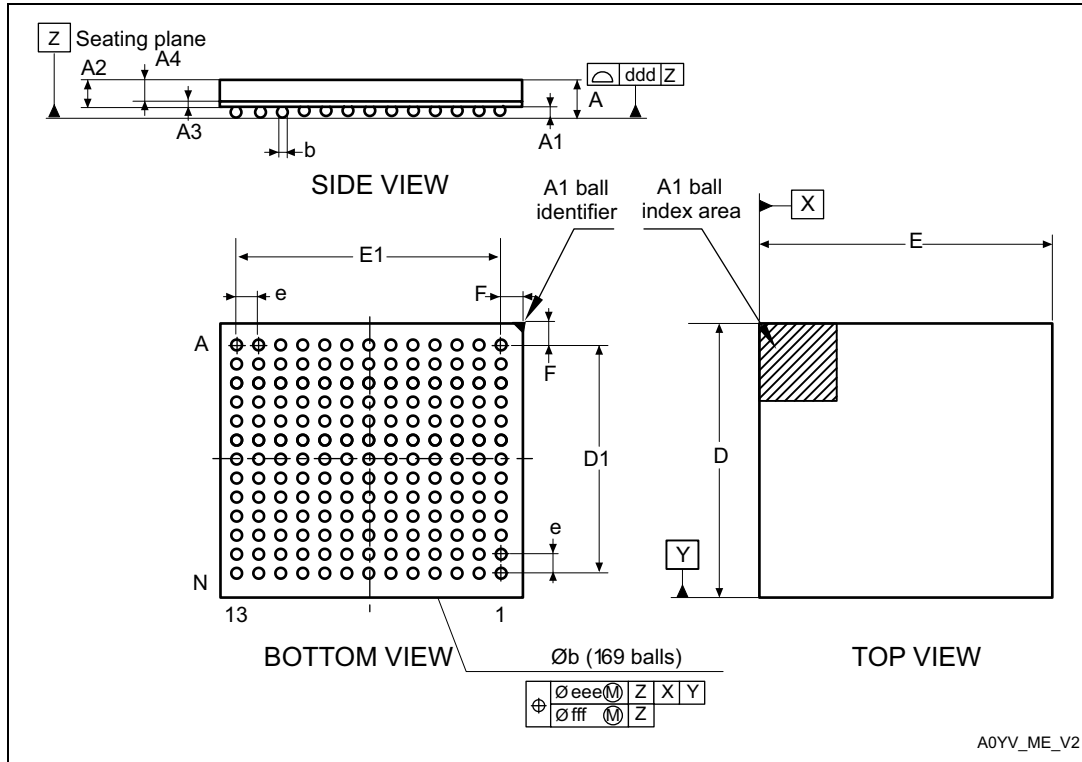

1. Drawing is not in scale.

Table 115. UFBGA169 - 169-pin, 7 x 7 mm, 0.50 mm pitch, ultra fine pitch ball grid array package mechanical data

Symbol	millimeters			inches ⁽¹⁾		
	Min.	Typ.	Max.	Min.	Typ.	Max.
A	0.460	0.530	0.600	0.0181	0.0209	0.0236
A1	0.050	0.080	0.110	0.0020	0.0031	0.0043
A2	0.400	0.450	0.500	0.0157	0.0177	0.0197
A3	-	0.130	-	-	0.0051	-
A4	0.270	0.320	0.370	0.0106	0.0126	0.0146
b	0.230	0.280	0.330	0.0091	0.0110	0.0130
D	6.950	7.000	7.050	0.2736	0.2756	0.2776
D1	5.950	6.000	6.050	0.2343	0.2362	0.2382
E	6.950	7.000	7.050	0.2736	0.2756	0.2776
E1	5.950	6.000	6.050	0.2343	0.2362	0.2382
e	-	0.500	-	-	0.0197	-

Table 115. UFBGA169 - 169-pin, 7 x 7 mm, 0.50 mm pitch, ultra fine pitch ball grid array package mechanical data (continued)

Symbol	millimeters			inches ⁽¹⁾		
	Min.	Typ.	Max.	Min.	Typ.	Max.
F	0.450	0.500	0.550	0.0177	0.0197	0.0217
ddd	-	-	0.100	-	-	0.0039
eee	-	-	0.150	-	-	0.0059
fff	-	-	0.050	-	-	0.0020

1. Values in inches are converted from mm and rounded to 4 decimal digits.

Device Marking for UFBGA169

The following figure gives an example of topside marking orientation versus ball A1 identifier location.

Figure 80. UFBGA169 marking example (package top view)

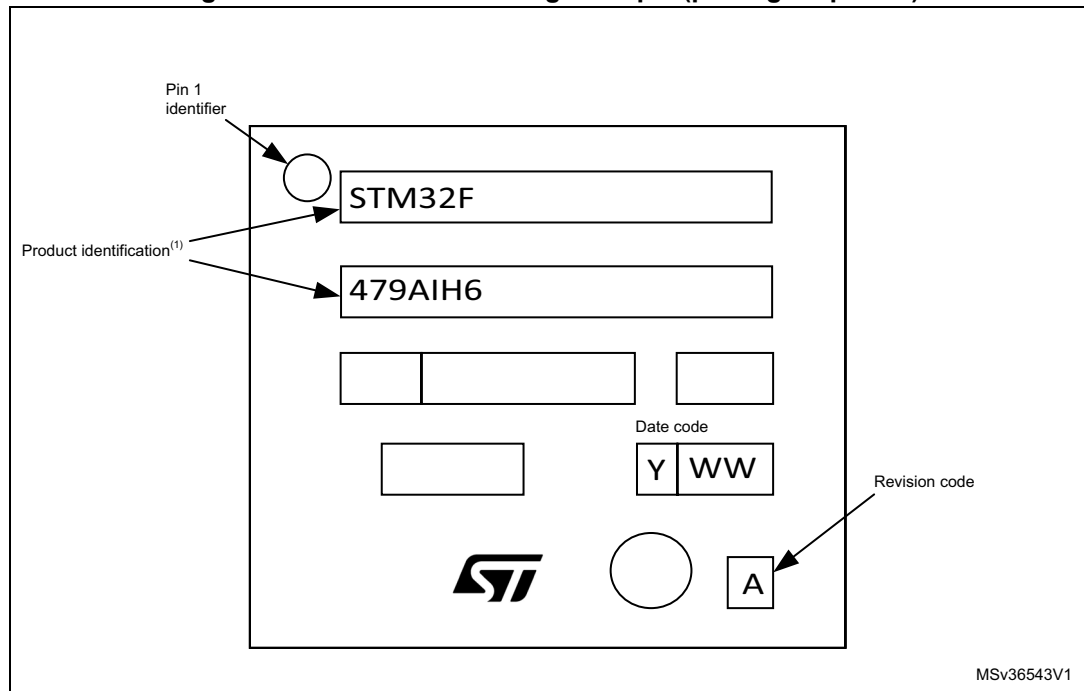

1. Samples marked "ES" are to be considered as "Engineering Samples": i.e. they are intended to be sent to customer for electrical compatibility evaluation and may be used to start customer qualification where specifically authorized by ST in writing. In no event ST will be liable for any customer usage in production. Only if ST has authorized in writing the customer qualification Engineering Samples can be used for reliability qualification trials.

6.3 LQFP176 package information

Figure 81. LQFP176, 24 x 24 mm, 176-pin low-profile quad flat package outline

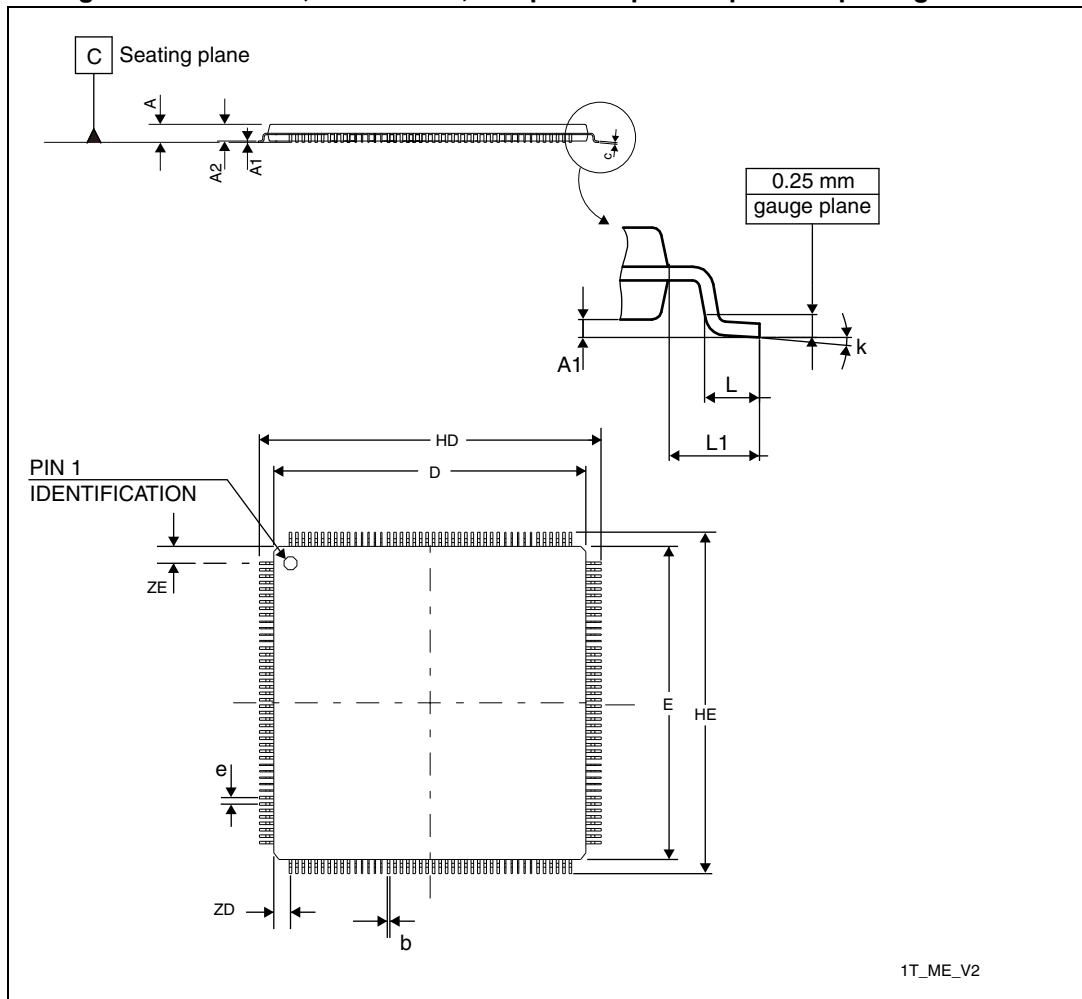

1. Drawing is not to scale.

Table 116. LQFP176, 24 x 24 mm, 176-pin low-profile quad flat package mechanical data

Symbol	millimeters			inches ⁽¹⁾		
	Min	Typ	Max	Min	Typ	Max
A	-	-	1.600	-	-	0.0630
A1	0.050	-	0.150	0.0020	-	0.0059
A2	1.350	-	1.450	0.0531	-	0.0060
b	0.170	-	0.270	0.0067	-	0.0106
C	0.090	-	0.200	0.0035	-	0.0079
D	23.900	-	24.100	0.9409	-	0.9488
E	23.900	-	24.100	0.9409	-	0.9488

**Table 116. LQFP176, 24 x 24 mm, 176-pin low-profile quad flat package
mechanical data (continued)**

Symbol	millimeters			inches ⁽¹⁾		
	Min	Typ	Max	Min	Typ	Max
e	-	0.500	-	-	0.0197	-
HD	25.900	-	26.100	1.0200	-	1.0276
HE	25.900	-	26.100	1.0200	-	1.0276
L	0.450	-	0.750	0.0177	-	0.0295
L1	-	1.000	-	-	0.0394	-
ZD	-	1.250	-	-	0.0492	-
ZE	-	1.250	-	-	0.0492	-
ccc	-	-	0.080	-	-	0.0031
k	0 °	-	7 °	0 °	-	7 °

1. Values in inches are converted from mm and rounded to 4 decimal digits.

Device Marking for LQFP176

The following figure gives an example of topside marking orientation versus pin 1 identifier location.

Figure 83. LQFP176 marking example (package top view)

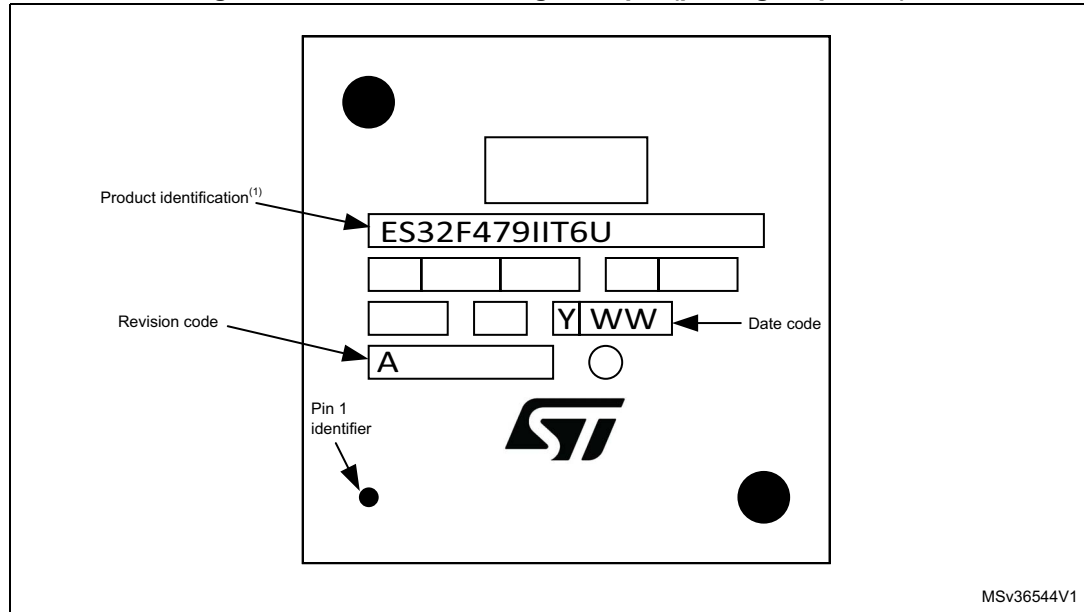

1. Samples marked "ES" are to be considered as "Engineering Samples": i.e. they are intended to be sent to customer for electrical compatibility evaluation and may be used to start customer qualification where specifically authorized by ST in writing. In no event ST will be liable for any customer usage in production. Only if ST has authorized in writing the customer qualification Engineering Samples can be used for reliability qualification trials.

6.4 UFBGA176+25 package information

Figure 84. UFBGA176+25 - 201-ball, 10 x 10 mm, 0.65 mm pitch, ultra fine pitch ball grid array package outline

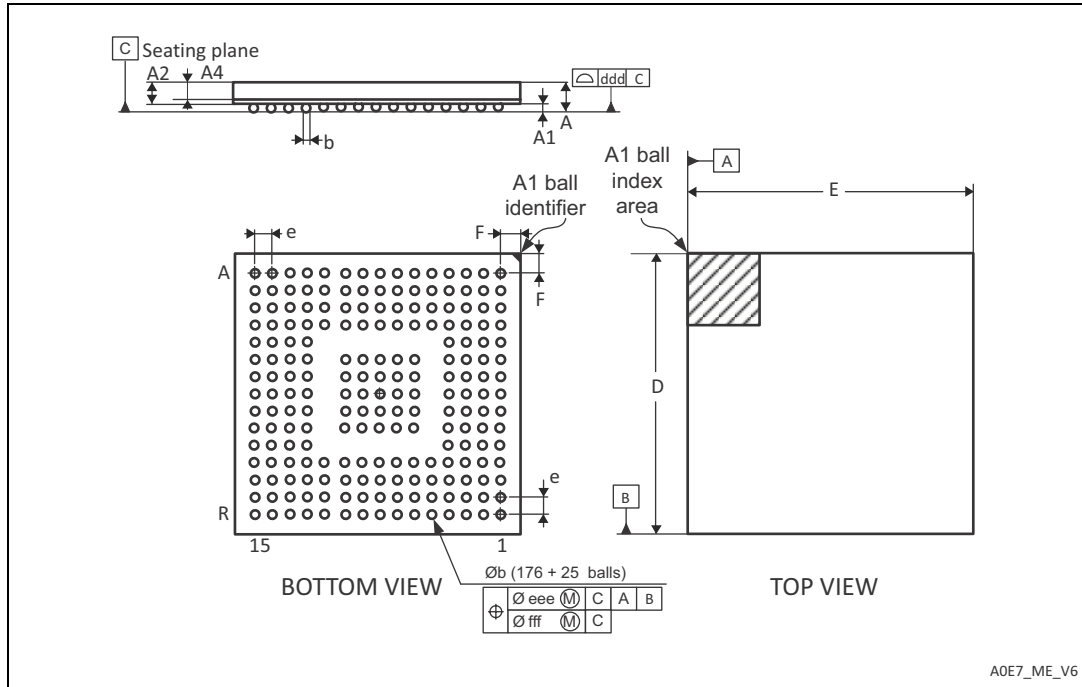

1. Drawing is not to scale.

Table 117. UFBGA176+25, - 201-ball, 10 x 10 mm, 0.65 mm pitch, ultra fine pitch ball grid array package mechanical data

Symbol	millimeters			inches ⁽¹⁾		
	Min.	Typ.	Max.	Min.	Typ.	Max.
A	0.460	0.530	0.600	0.0181	0.0209	0.0236
A1	0.050	0.080	0.110	0.0020	0.0031	0.0043
A2	0.400	0.450	0.500	0.0157	0.0177	0.0197
A4	0.270	0.320	0.370	0.0106	0.0126	0.0146
b	0.230	0.280	0.330	0.0091	0.0110	0.0130
D	9.950	10.000	10.050	0.3917	0.3937	0.3957
E	9.950	10.000	10.050	0.3917	0.3937	0.3957
e	-	0.650	-	-	0.0256	-
F	0.400	0.450	0.500	0.0157	0.0177	0.0197
ddd	-	-	0.080	-	-	0.0031
eee	-	-	0.150	-	-	0.0059
fff	-	-	0.080	-	-	0.0031

1. Values in inches are converted from mm and rounded to 4 decimal digits.

Figure 85. UFBGA176+25 - 201-ball, 10 x 10 mm, 0.65 mm pitch, ultra fine pitch ball grid array package recommended footprint

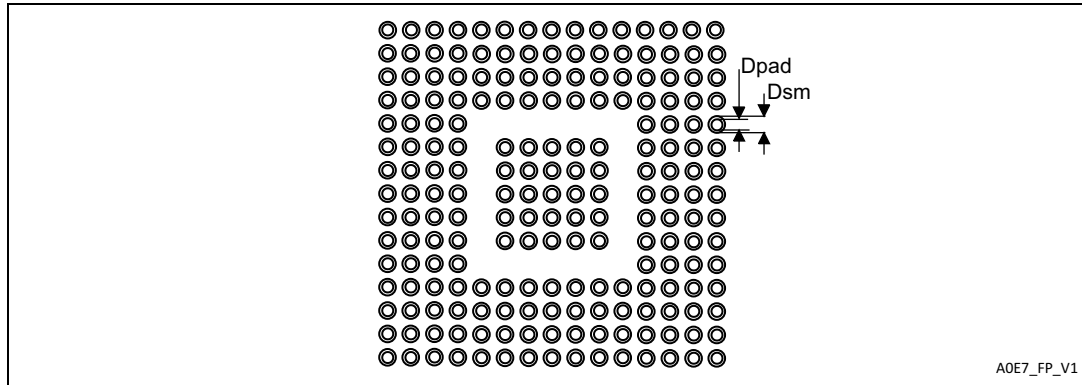
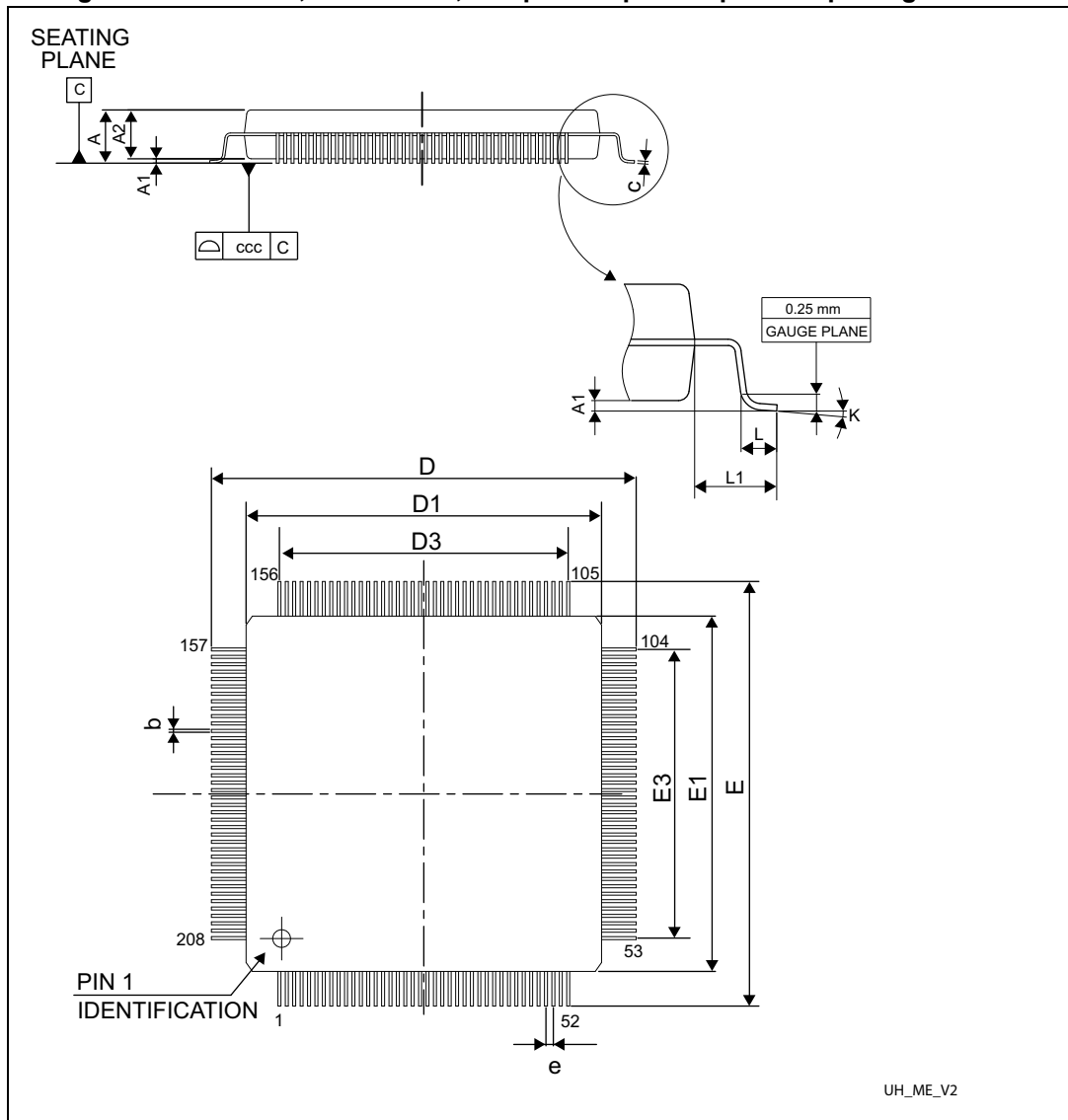

Table 118. UFBGA176+25 recommended PCB design rules (0.65 mm pitch BGA)

Dimension	Recommended values
Pitch	0.65 mm
Dpad	0.300 mm
Dsm	0.400 mm typ. (depends on the soldermask registration tolerance)
Stencil opening	0.300 mm
Stencil thickness	Between 0.100 mm and 0.125 mm
Pad trace width	0.100 mm

6.5 LQFP208 package information

Figure 86. LQFP208, 28 x 28 mm, 208-pin low-profile quad flat package outline



1. Drawing is not to scale.

Table 119. LQFP208, 28 x 28 mm, 208-pin low-profile quad flat package mechanical data

Symbol	millimeters			inches ⁽¹⁾		
	Min	Typ	Max	Min	Typ	Max
A	-	-	1.600	--	-	0.0630
A1	0.050	-	0.150	0.0020	-	0.0059
A2	1.350	1.400	1.450	0.0531	0.0551	0.0571
b	0.170	0.220	0.270	0.0067	0.0087	0.0106

**Table 119. LQFP208, 28 x 28 mm, 208-pin low-profile quad flat package
mechanical data (continued)**

Symbol	millimeters			inches ⁽¹⁾		
	Min	Typ	Max	Min	Typ	Max
c	0.090	-	0.200	0.0035	-	0.0079
D	29.800	30.000	30.200	1.1732	1.1811	1.1890
D1	27.800	28.000	28.200	1.0945	1.1024	1.1102
D3	-	25.500	-	-	1.0039	-
E	29.800	30.000	30.200	1.1732	1.1811	1.1890
E1	27.800	28.000	28.200	1.0945	1.1024	1.1102
E3	-	25.500	-	-	1.0039	-
e	-	0.500	-	-	0.0197	-
L	0.450	0.600	0.750	0.0177	0.0236	0.0295
L1	-	1.000	-	-	0.0394	-
k	0°	3.5°	7.0°	0°	3.5°	7.0°
ccc	-	-	0.080	-	-	0.0031

1. Values in inches are converted from mm and rounded to 4 decimal digits.

Figure 87. LQFP208 recommended footprint

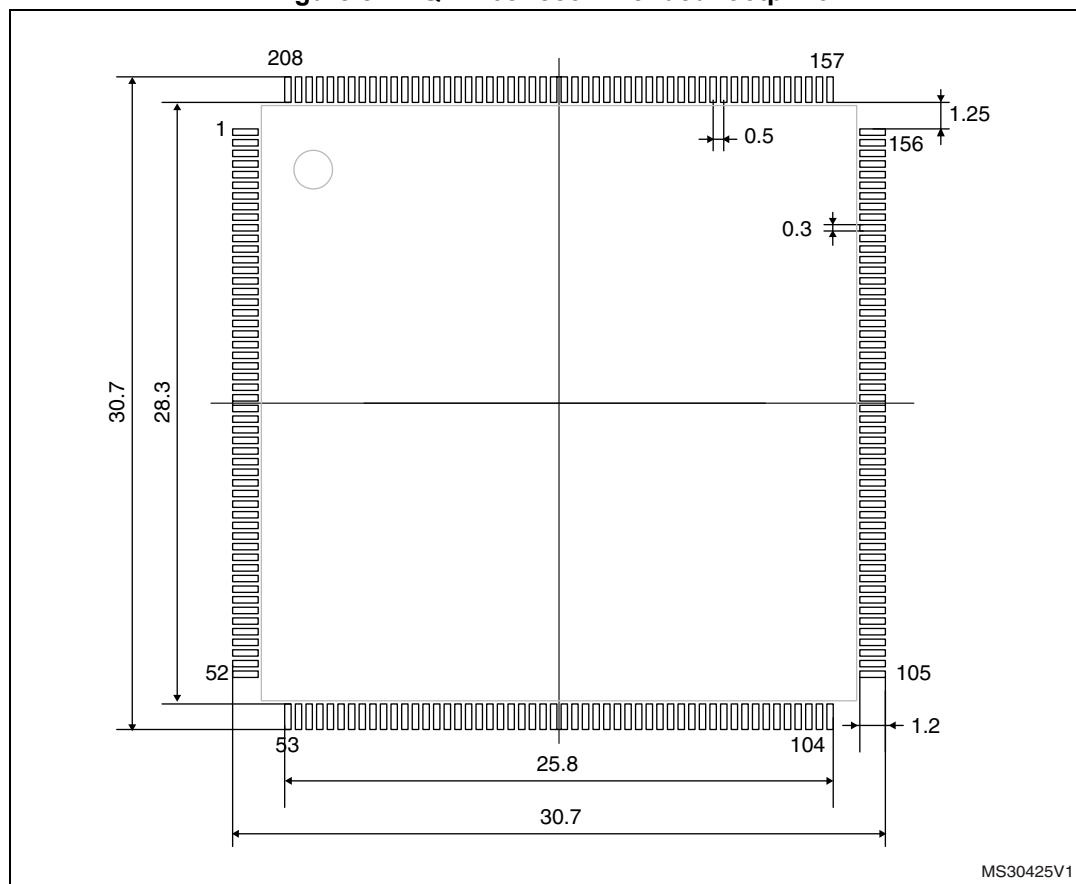

1. Dimensions are expressed in millimeters.

Device Marking for LQFP208

The following figure gives an example of topside marking orientation versus pin 1 identifier location.

Figure 88. LQFP208 marking example (package top view)

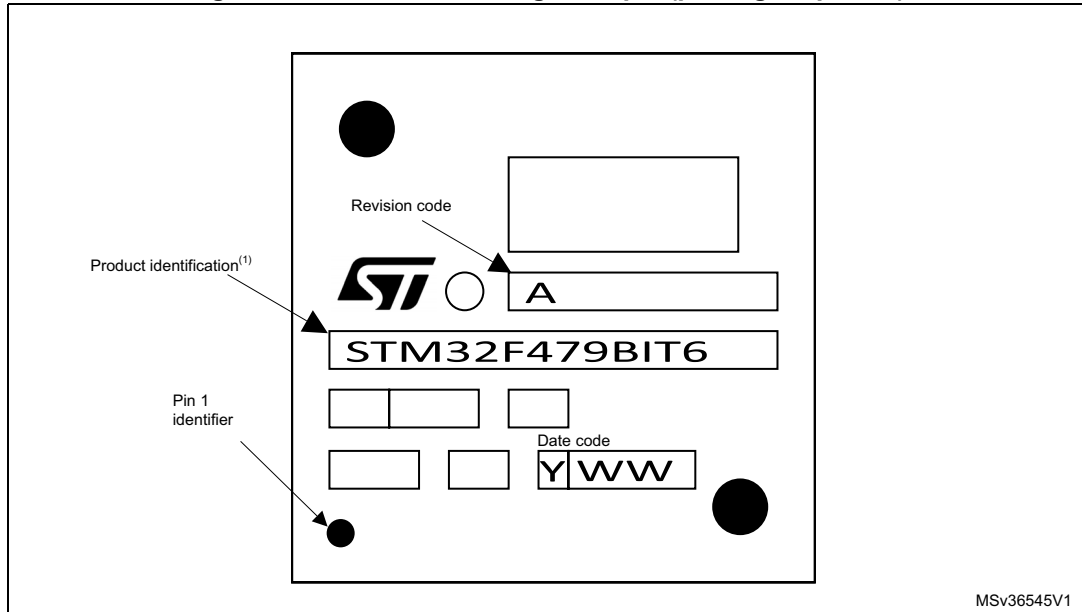

1. Samples marked "ES" are to be considered as "Engineering Samples": i.e. they are intended to be sent to customer for electrical compatibility evaluation and may be used to start customer qualification where specifically authorized by ST in writing. In no event ST will be liable for any customer usage in production. Only if ST has authorized in writing the customer qualification Engineering Samples can be used for reliability qualification trials.

6.6 TFBGA216 package information

Figure 89. TFBGA216 - thin fine pitch ball grid array 13 × 13 × 0.8mm, package outline

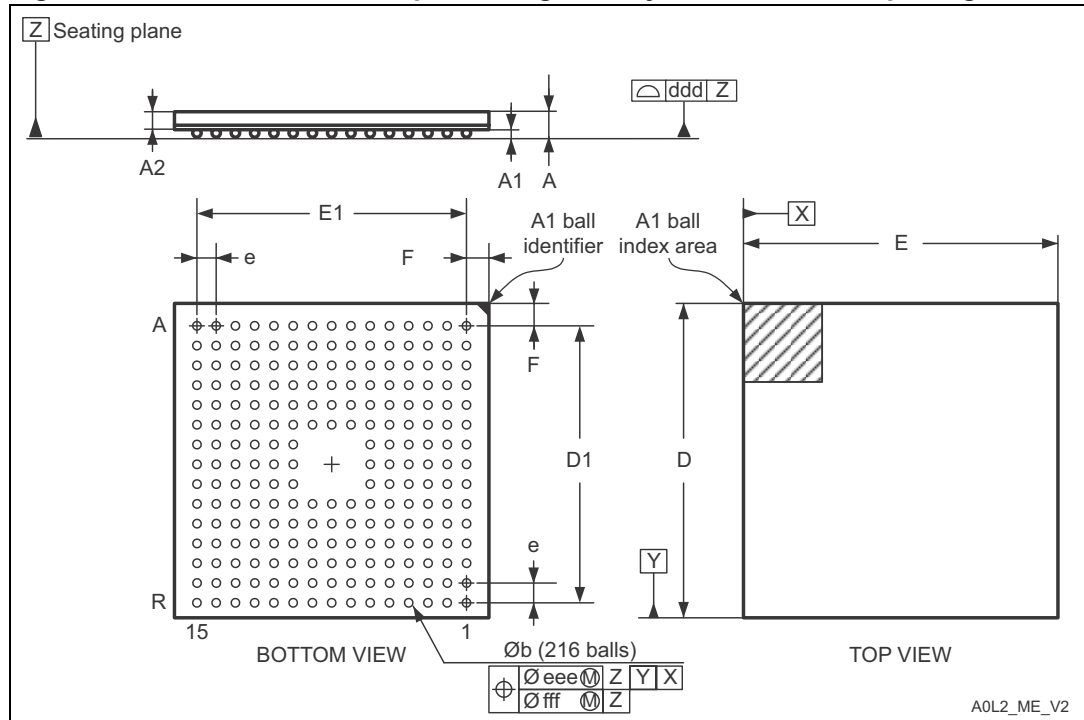

1. Drawing is not to scale.

Table 120. TFBGA216 - thin fine pitch ball grid array 13 × 13 × 0.8mm package mechanical data

Symbol	millimeters			inches ⁽¹⁾		
	Min	Typ	Max	Min	Typ	Max
A	-	-	1.100	-	-	0.0433
A1	0.150	-	-	0.0059	-	-
A2	-	0.760	-	-	0.0299	-
A4	-	0.210	-	-	0.0083	-
b	0.350	0.400	0.450	0.0138	0.0157	0.0177
D	12.850	13.000	13.150	0.5118	0.5118	0.5177
D1	-	11.200	-	-	0.4409	-
E	12.850	13.000	13.150	0.5118	0.5118	0.5177
E1	-	11.200	-	-	0.4409	-
e	-	0.800	-	-	0.0315	-
F	-	0.900	-	-	0.0354	-
ddd	-	-	0.080	-	-	0.0031

1. Values in inches are converted from mm and rounded to 4 decimal digits.

Device Marking for TFBGA216

The following figure gives an example of topside marking orientation versus ball A1 identifier location.

Figure 90. TFBGA216 marking example (package top view)

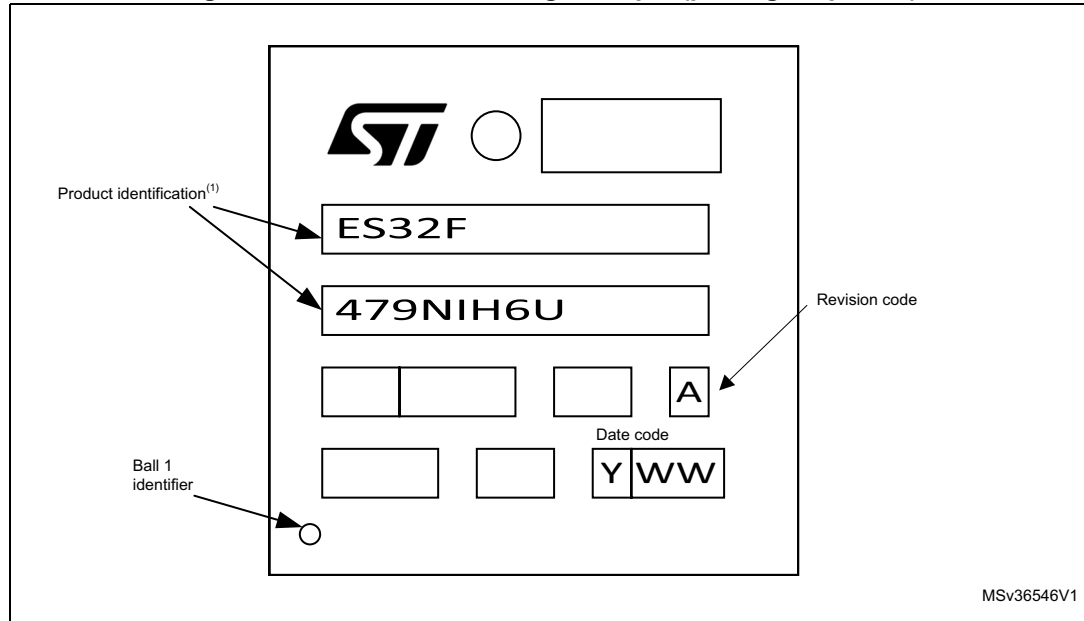

1. Samples marked "ES" are to be considered as "Engineering Samples": i.e. they are intended to be sent to customer for electrical compatibility evaluation and may be used to start customer qualification where specifically authorized by ST in writing. In no event ST will be liable for any customer usage in production. Only if ST has authorized in writing the customer qualification Engineering Samples can be used for reliability qualification trials.

6.7 Thermal characteristics

The maximum chip-junction temperature, $T_J \text{ max}$, in degrees Celsius, may be calculated using the following equation:

$$T_J \text{ max} = T_A \text{ max} + (P_D \text{ max} \times \Theta_{JA})$$

Where:

- $T_A \text{ max}$ is the maximum ambient temperature in °C,
- Θ_{JA} is the package junction-to-ambient thermal resistance, in °C/W,
- $P_D \text{ max}$ is the sum of $P_{INT} \text{ max}$ and $P_{I/O} \text{ max}$ ($P_D \text{ max} = P_{INT} \text{ max} + P_{I/O} \text{ max}$),
- $P_{INT} \text{ max}$ is the product of I_{DD} and V_{DD} , expressed in Watts. This is the maximum chip internal power.

$P_{I/O} \text{ max}$ represents the maximum power dissipation on output pins where:

$$P_{I/O} \text{ max} = \Sigma (V_{OL} \times I_{OL}) + \Sigma ((V_{DD} - V_{OH}) \times I_{OH}),$$

taking into account the actual V_{OL} / I_{OL} and V_{OH} / I_{OH} of the I/Os at low and high level in the application.

Table 121. Package thermal characteristics

Symbol	Parameter	Value	Unit
Θ_{JA}	Thermal resistance junction-ambient WLCSP168	31	°C/W
	Thermal resistance junction-ambient LQFP176 - 24 × 24 mm / 0.5 mm pitch	38	
	Thermal resistance junction-ambient LQFP208 - 28 × 28 mm / 0.5 mm pitch	19	
	Thermal resistance junction-ambient UFBGA169 - 7 × 7mm / 0.5 mm pitch	52	
	Thermal resistance junction-ambient UFBGA176 - 10 × 10 mm / 0.5 mm pitch	39	
	Thermal resistance junction-ambient TFBGA216 - 13 × 13 mm / 0.8 mm pitch	29	

Reference document

JESD51-2 Integrated Circuits Thermal Test Method Environment Conditions - Natural Convection (Still Air). Available from www.jedec.org.

7 Part numbering

Table 122. Ordering information scheme

Example:	STM32	F	469	V	I	T	6	xxx
Device family								
STM32 = ARM-based 32-bit microcontroller								
Product type								
F = general-purpose								
Device subfamily								
469= STM32F469xx, USB OTG FS/HS, camera interface, Ethernet, LCD-TFT, DSIHost, Quad-SPI, Chrom-ART graphical accelerator.								
Pin count								
A = 168 and 169 pins								
I = 176 pins								
B = 208 pins								
N = 216 pins								
Flash memory size								
E = 512 Kbytes of Flash memory								
G = 1024 Kbytes of Flash memory								
I = 2048 Kbytes of Flash memory								
Package								
T = LQFP								
H = BGA								
Y = WLCSP								
Temperature range								
6 = Industrial temperature range, -40 to 85 °C.								
7 = Industrial temperature range, -40 to 105 °C.								
Options								
xxx = programmed parts								
TR = tape and reel								

For a list of available options (speed, package, etc.) or for further information on any aspect of this device, please contact your nearest ST sales office.

Appendix A Recommendations when using internal reset OFF

When the internal reset is OFF, the following integrated features are no longer supported:

- The integrated power-on reset (POR) / power-down reset (PDR) circuitry is disabled.
- The brownout reset (BOR) circuitry must be disabled.
- The embedded programmable voltage detector (PVD) is disabled.
- V_{BAT} functionality is no more available and VBAT pin should be connected to V_{DD}.
- The over-drive mode is not supported.

A.1 Operating conditions

Table 123. Limitations depending on the operating power supply range

Operating power supply range	ADC operation	Maximum Flash memory access frequency with no wait states (f _{Flashmax})	Maximum Flash memory access frequency with wait states ⁽¹⁾⁽²⁾	I/O operation	Possible Flash memory operations
V _{DD} =1.7 to 2.1 V ⁽³⁾	Conversion time up to 1.2 Msps	20 MHz ⁽⁴⁾	168 MHz with 8 wait states and over-drive OFF	– No I/O compensation	8-bit erase and program operations only

1. Applicable only when the code is executed from Flash memory. When the code is executed from RAM, no wait state is required.
2. Thanks to the ART accelerator and the 128-bit Flash memory, the number of wait states given here does not impact the execution speed from Flash memory since the ART accelerator allows to achieve a performance equivalent to 0 wait state program execution.
3. V_{DD}/V_{DDA} minimum value of 1.7 V, with the use of an external power supply supervisor (refer to [Section 2.19.1: Internal reset ON](#)).
4. Prefetch is not available. Refer to AN3430 application note for details on how to adjust performance and power.

8 Revision history

Table 124. Document revision history

Date	Revision	Changes
01-Sep-2015	1	Initial release.
13-Oct-2015	2	Updated Table 4: Regulator ON/OFF and internal reset ON/OFF availability and Table 54: EMI characteristics . Updated Figure 33: PLL output clock waveforms in center spread mode and Figure 34: PLL output clock waveforms in down spread mode . Updated title of Section 6.6: TFBGA216 package information .

IMPORTANT NOTICE – PLEASE READ CAREFULLY

STMicroelectronics NV and its subsidiaries ("ST") reserve the right to make changes, corrections, enhancements, modifications, and improvements to ST products and/or to this document at any time without notice. Purchasers should obtain the latest relevant information on ST products before placing orders. ST products are sold pursuant to ST's terms and conditions of sale in place at the time of order acknowledgement.

Purchasers are solely responsible for the choice, selection, and use of ST products and ST assumes no liability for application assistance or the design of Purchasers' products.

No license, express or implied, to any intellectual property right is granted by ST herein.

Resale of ST products with provisions different from the information set forth herein shall void any warranty granted by ST for such product.

ST and the ST logo are trademarks of ST. All other product or service names are the property of their respective owners.

Information in this document supersedes and replaces information previously supplied in any prior versions of this document.

© 2015 STMicroelectronics – All rights reserved

X-ON Electronics

Largest Supplier of Electrical and Electronic Components

Click to view similar products for [32-bit Microcontrollers - MCU category](#):

Click to view products by [STMicroelectronics manufacturer](#):

Other Similar products are found below :

[MB91101APFR-G-JNE1](#) [MB91F469GBP-B-GSE1](#) [MB91F522KWBPMC-GSE2](#) [MB91F526LKCPMC-GSE2](#) [MB91F575BHSPMC-GSE1](#)
[MB91F594BSPMC-GSE1](#) [MCF51AC256AVFUE](#) [MCF51AC256AVLKE](#) [MCF5282CVF66](#) [PIC32MX120F032B-50I/SS](#)
[SPC560C50L3B4E0X](#) [SPC560P40L1CEFBR](#) [PIC32MX120F032B-50I/ML](#) [MB91F464AAPMC-GSE2](#) [MB91F524FSCPMC-GSE2](#)
[MB91F53BCEQ-GSAE2](#) [MB91F577BHSPMC-GSE1](#) [MB91F59BCPB-GSE1](#) [SPC5604EEF2MLH](#) [MCF5282CVM66](#) [MCF51AC256BVLKE](#)
[MB91F579CHSPMC1-GSE1](#) [MB91F528UWCEQ-GSE2](#) [MB91F528USCPMC-GSE2](#) [R5F104LJAFBV0](#) [SPC5606BK0VLQ6](#)
[R5S726B0D216FP#V0](#) [SPC564A70L7CFAY](#) [TC299TX128F300NBCKXUMA1](#) [SPC58EC80E1Q0C0Y](#) [R5S72691W266FP#V0](#)
[TC275T64F200WCAKXUMA1](#) [PIC32MM0016GPL028-I/SS](#) [MB91F592BHSPMC-GSE1](#) [SPC5746CSK1MMH6](#) [SPC5777MK0MVA8](#)
[R5S72630P200FP](#) [R5F72855D100FP#U2](#) [MB91F069BSCPMC1-GSE1](#) [SPC564A80AVB324](#) [SPC5777MK0MVU8](#) [MB91F469GBP-B-GS-](#)
[N2](#) [R8A77210C133BGV](#) [MB91F594BPMC-GSE1](#) [UPD70F3623GBA-GAH-QS-AX](#) [MB91243PFV-GS-136E1](#) [SPC5741PK1AMLQ8](#)
[AT32UC3A4128S-C1UT](#) [PIC32MX130F064D-50I/PT](#) [AT32UC3A4256-C1UT](#)