

# Energy Management Energy Meter Type EM111

CARLO GAVAZZI

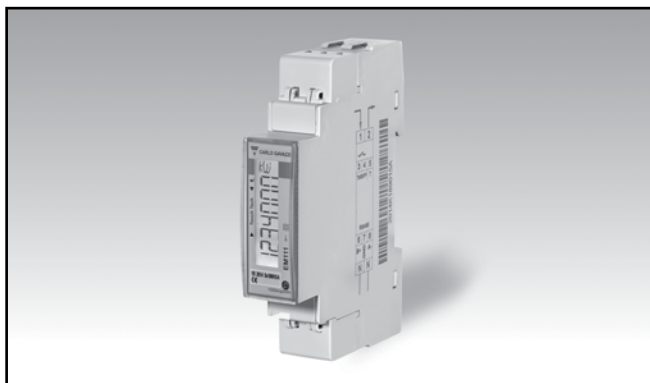

- Easy connection or wrong current direction detection
- Other versions available (not certified, option X: see "how to order" on the next page)

- Single phase energy meter
- Class 1 (kWh) according to EN62053-21
- Class B (kWh) according to EN50470-3
- Accuracy  $\pm 0.5\%$  RDG (current/voltage)
- Direct current measurement up to 45AAC
- Backlit LCD display with integrated touch key-pad
- Energy readout on display: 7 digit
- Variable readout on display: 4 digit
- Energy measurement: kWh and kvarh (imported/exported); kWh+ by 2 tariffs
- System variables, kW, kvar, V, A, PF, Hz, kWdmd, kWdmd peak
- Self power supply
- Dimensions: 1-DIN module
- Protection degree (front): IP51
- Pulse output (optional, by opto-mosfet)
- RS485 Modbus port (optional)
- M-bus port (optional)
- Digital input (for tariff management)

## Product description

Single-phase energy meter with backlit LCD display with integrated touch keypad. Particularly indicated for active energy metering and for cost allocation in

applications up to 45 A (direct connection), with dual tariff management availability. It can measure imported and exported energy or be programmed to

consider only the imported one. Housing for DIN-rail mounting, with IP51 front degree protection. The meter is optionally provided with pulse output proportional

to the active energy being measured, RS485 Modbus port or M-bus port. Available for legal metrology (PF option, only for imported energy).

### STANDARD

Not certified according to MID Directive. Cannot be used for fiscal (legal) metrology.

### How to order **EM111-DIN AV8 1 X O1 X**

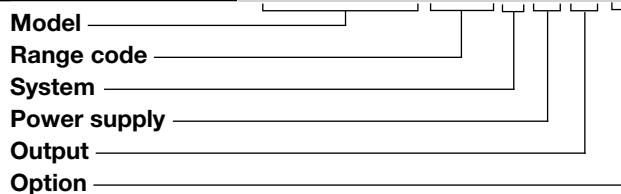

## Type Selection

Range code	System	Power supply	Output
<b>AV8:</b> 230VLN AC - 5(45)A (Direct connection)	<b>1:</b> 1-phase 2-wire	<b>X:</b> Self power supply -30% +20% of the rated measuring input voltage, 45 to 65Hz	<b>O1:</b> pulse output <b>S1:</b> RS485 Modbus port <b>M1:</b> M-bus port
<b>AV7:</b> 120VLN AC - 5(45)A (Direct connection)			

### Option

**X:** none

## Input specifications

<b>Rated Inputs</b>			
Current type	1-phase loads, direct connection	Energies (negative)	0.1kWh or kvarh (display: autoranging up to 1 kWh or kvarh) 0.01kWh or kvarh (serial comm.)
Current range	5(45)A	<b>Energy additional errors</b>	
Nominal voltage	230VLN AC (AV8 option), 120 VLN (AV7 option)	Influence quantities	According to EN62053-21
<b>Accuracy</b>		<b>Temperature drift</b>	≤200ppm/°C
(@25°C ±5°C, R.H. ≤60%, 45 to 65 Hz)		<b>Sampling rate</b>	4096 samples/s @ 50Hz 4096 samples/s @ 60Hz
AV7	I <sub>min</sub> =0.25A; I <sub>b</sub> : 5A, I <sub>max</sub> : 45A; Un: 120VLN -30% +30%	<b>Display and touch key-pad</b>	
AV8	I <sub>min</sub> =0.25A; I <sub>b</sub> : 5A, I <sub>max</sub> : 45A; Un: 230VLN -30% +20%	Type	Backlit LCD, 7-digit, h 6 mm
Current (AV7, AV8)	From 0.04I <sub>b</sub> to 0.2I <sub>b</sub> : ±(0.5%RDG+1DGT) From 0.2I <sub>b</sub> to I <sub>max</sub> : ±(0.5%RDG)	Read-out	Energy: 8 digit. Variables: 4 digit
Phase-neutral voltage	In the range Un: ±(0.5% RDG)	Touch key	2 (Enter and UP). Scrolling the keys up and down the functions UP and DOWN can be carried out
Frequency	Range: 45 to 65Hz.	<b>Max. and Min. indication</b>	Max. 999 999.9 Min. 0.0
Active power	From 0.05 I <sub>n</sub> to I <sub>max</sub> , within Un range, PF=1: ±(1% RDG) From 0.1 I <sub>n</sub> to I <sub>max</sub> , within Un range, PF=0.5L or 0.8C: ±(1% RDG)	<b>Memory energy storage</b>	
Power factor	±[0.001+1%(1.000 - "PF RDG")]	Energy	10 <sup>10</sup> cycles. Energy value is saved every time the less significant digit increases.
Reactive power	From 0.05 I <sub>n</sub> to I <sub>max</sub> , within Un range, sinphi=1: ±(2% RDG) From 0.1 I <sub>n</sub> to I <sub>max</sub> , within Un range, sinphi=0.5L or 0.8C: ±(2% RDG)	Programming parameters	10 <sup>10</sup> cycles. When a parameter is modified, only the relevant memory cell is overwritten
Energies		<b>LEDs</b>	Flashing red light pulses according to EN50470-3, EN62052-11, 1000 imp./kWh (min. period: 90ms) Fix orange light: wrong current direction (only with PF option or with "B" measurement selection in case of X option)
Active energy	Class 1 according to EN62053-21	<b>Current overloads</b>	
Reactive energy	Class 2 according to EN62053-23	Continuous	45A, @ 50Hz
Start-up current:	20mA (AV7, AV8) Self-consumption is not measured.	For 10ms	1350 A
Start-up voltage	84VLN (AV7), 161VLN (AV8)	<b>Voltage Overloads</b>	
<b>Resolution (also via serial port)</b>		Continuous	1.2 Un
Current	0.1A	For 500ms	2 Un
Voltage	0.1V	<b>Input impedance</b>	
Power	0.1kW or kvar	Voltage input 230VL-N	1.2 Mohm
Frequency	0.1 Hz	Voltage input 120VL-N	1.2 Mohm
PF	0.01	Current inputs: 5(45) A	< 0.5 VA
Energies (positive)	0.01kWh or kvarh (display: autoranging up to 1 kWh or kvarh) 0.01kWh or kvarh (serial comm.)		

## Digital input specifications

<b>Digital inputs</b>	Free of voltage contact	Overload	100kohm, open contact
Function	Tariff management (switch between t1-t2)		In case a voltage is erroneously applied to the digital input, the input is not damaged up to 30 VAC/DC.
Number of inputs	1		
Contact measurement voltage	5 V		
Input impedance	1kohm		
Contact resistance	1kohm, close contact		

## Output specifications

<b>RS485 serial port</b>	RS485 by screw connection.	Secondary address	Univocally defined in each unit
Function	For communication of measured data, programming parameters	Identification number range	from 5000 0000 to 6999 9999
Protocol	Modbus RTU (slave function)	Other	Available functions: wild card, header, initialisation SND_NKE, and req_uds management. Management of primary address modification via M-bus and reset of partial energy via M-bus available.
Baud rate	9.6, 19.2, 38.4, 57.6, 115.2 kbaud, even or no parity,		VIF, VIFE, DIF and DIFE: see protocol
Address	1 to 247 (default: 01)		
Driver input capability	1/8 unit load. Maximum 247 transceivers on the same bus.		
Data refresh time	1sec		
Read command	50 words available in 1 read command	<b>Static output</b>	
Rx/Tx indication	Rx segment on display is shown when a valid Modbus command is sent to that specific meter Tx segment on display is shown when a valid Modbus reply is sent back to the master	Purpose	For pulse output proportional to the active energy (kWh)
		Pulse rate	Selectable in multiple of 100 Max 1000 or 3000 kWh according to pulse ON duration
		Pulse ON duration	Selectable: 30ms or 100 ms according to EN62052-31
<b>M-bus port</b>	M-bus by screw connection.	Output type	Opto-mosfet
Function	For communication of measured data	Load	$V_{ON}$ 2.5 VAC/DC max. 100mA $V_{OFF}$ 260 VAC max.
Protocol	M-bus according to EN13757-1		
Baud rate	0.3, 2.4, 9.6 kbaud		
Meters in the M-bus network	250		
Primary address	Selectable		

## General specifications

<b>Operating temperature</b>	-20 to +65 °C, indoor, (R.H. from 0 to 90% non-condensing @ 40°C)	<b>Standard compliance</b>	
<b>Storage temperature</b>	-30°C to +80°C (R.H. < 90% noncondensing @ 40°C)	Safety	IEC60664, IEC61010-1 EN60664, EN61010-1 EN62052-11 EN62053-21, EN50470-3
<b>Installation category</b>	Cat. III (IEC 60664, EN60664)	Metrology	
<b>Insulation (for 1 minute)</b>	4000 VAC RMS between measuring inputs and digital/serial output (see table) 4000 VAC RMS	<b>Approvals</b>	CE (cULus pending)
<b>Dielectric strength</b>	4000 VAC RMS for 1 minute	<b>Connections</b>	
<b>EMC</b>		Cable cross-section area	Measuring inputs: max. 6 mm <sup>2</sup> with/without metallic cable ferrule; Max. screw tightening torque: 1.1 Nm 1.5 mm <sup>2</sup> , Min./Max. screws tightening torque: 0.4 Nm
Electrostatic discharges	According to EN62052-11 15kV air discharge;	Other terminals	
Immunity to irradiated	Test with current: 10V/m from 80 to 2000MHz;	<b>Housing</b>	
Electromagnetic fields	Test without any current: 30V/m from 80 to 2000MHz;	Dimensions (WxHxD)	17.5 x 63 x 90 mm
Burst	On current and voltage measuring inputs circuit: 4kV	Material	Noryl, self-extinguishing: UL 94 V-0
Immunity to conducted disturbances	10V/m from 150KHz to 80MHz	Sealing covers	Included
Surge	On current and voltage measuring inputs circuit: 4kV;	<b>Mounting</b>	DIN-rail
Radio frequency	According to CISPR 22	<b>Protection degree</b>	
		Front	IP51
		Screw terminals	IP20
		<b>Weight</b>	Approx. 80 g (packing included)

## Power supply specifications

<b>Self power supply</b>		<b>Power consumption</b>	≤ 1.0W, ≤ 8VA
AV8	230VAC VL-N, -30% +20% 50/60Hz		
AV7	120VAC VL-N, -30% +30% 50/60Hz		

## Insulation (for 1 minute) between inputs and outputs

	Measuring input	Auxiliary power supply	Digital or serial output	Digital input
Measuring input	-	0 kV	4 kV	4 kV
Auxiliary power supply	0 kV	-	4 kV	4 kV
Digital or serial output	4 kV	4 kV	-	4 kV
Digital input	4 kV	4 kV	4 kV	-

## Accuracy (according to EN50470-3 and EN62053-23)

kWh, PF=accuracy (RDG) depending on the current

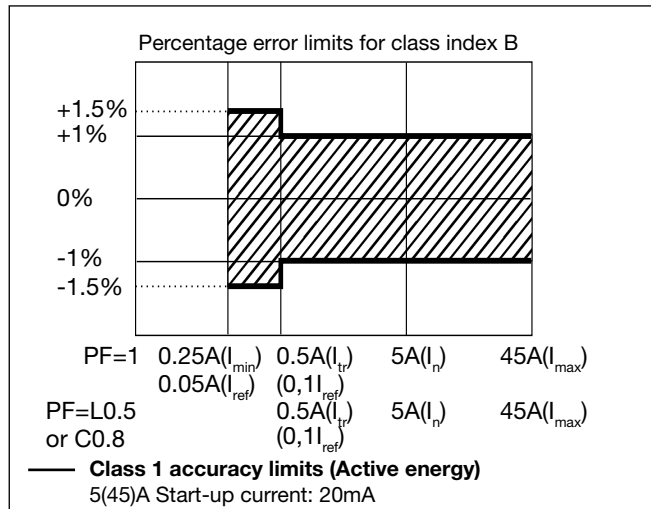

kvarh, accuracy (RDG) depending on the current

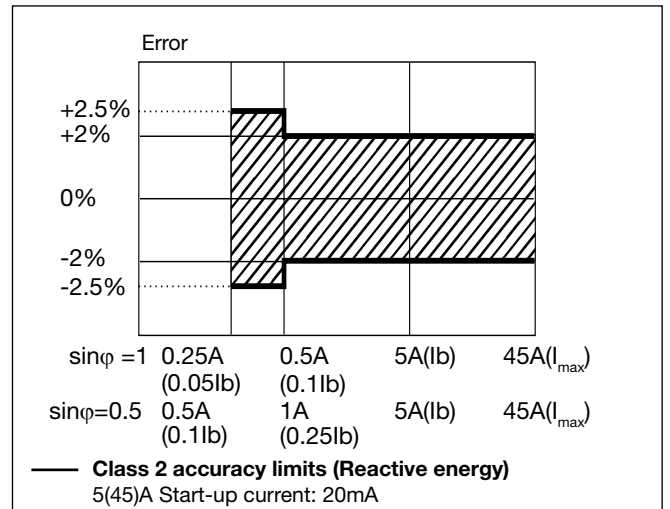

## Display pages

No	Variable	“Full” mode	“Easy” mode	Note
0	kWh+ (imported)	X	X	In PFA version and in X version with Measurement menu set to “A”, this is considering the total energy without considering the current direction.
1	kWh- (exported)	X	X	Only in X version, with Measurement menu set to “B”
2	kW	X	X	
3	V	X	X	
4	A	X	X	
5	PF	X		
6	Hz	X		
7	kvarh+ (imported)	X		In PFA version and in X version with Measurement menu set to “A”, this is considering the total positive reactive energy without considering the current direction.
8	kvarh- (exported)	X		Only in X version, with Measurement menu set to “B”
9	kvar	X		
10	kW dmd	X		
11	kW dmd peak	X		
12	kWh (t1)	X	X	Only relevant to kWh+, with Tariff menu set to ON
13	kWh (t2)	X	X	Only relevant to kWh+, with Tariff menu set to ON

X= available

## List of available menus

Menu name and description		Range	Default setting
PASS	Password request	From 0000 to 9999	0000
nPASS	New password	From 0000 to 9999	0000
Measure	Measurement type (A=easy connection; B=bidirectional, imported and exported energy).	A; b	A
P int	Integration time for Wdmd calculation	1 to 30 min	1
Mode	Selection of complete or simplified set of variables on display	Full or Easy	Full
Tariff	Tariff enabling	Yes/No	No
Pulse (O1 option)	Selection of pulse ON duration	30 or 100 ms	30
	Selection of the pulse rate	100 to 1000 (if duration is 100ms) or to 3000 (if 30 ms)	100
Address (S1 option)	Modbus serial address	1 to 247	01
Kbaud (S1)	Modbus baud rate	9.6; 19.2; 38.4; 57.6, 115.2 kbps	9.6
Parity (S1)	Modbus parity	No/even	No
Primary address (M1 option)	M-bus primary address	1 to 250	1
Kbaud (M1)	M-bus baud rate	0.3; 2.4; 9.6 kbps	2.4
Reset	Allow the reset of tariff meters and W dmd peak and of the kWh/kvarh partial meter available only via serial communication	Yes/No	No
End	Exit to measuring mode		

**Note:** after the confirmation of a new parameter value, the value is stored in the memory without the need to exit the programming mode.

## Additional available information on the display (\*)

Type	Description	Note
Info page 1	Year (2013)	Year of production
Info page 2	Serial (dddnnnA)	Serial number (ddd= day of the year; nnn=progressive number; A= production line, internal use only)
Info page 3	Rev (A.01)	Firmware revision
Info page 4	Measure	Measurement type
Info page 5	P int	Integration time for Wdmd calculation
Info page 6	Mode	Set of variables on display
Info page 7	Tariff	Tariff enabling
Info page 8 (O1)	Pulse	Pulse ON duration
		Pulse rate
Info page 8 (S1)	Address	Modbus serial address
Info page 9 (S1)	Kbaud	Modbus baud rate
Info page 10 (S1)	Parity	Modbus parity
Info page 8 (M1)	Primary address	M-bus primary address
Info page 9 (M1)	Kbaud	M-bus baud rate

(\*) can be reached by pressing simultaneously the 2 touch keys

## Wiring diagrams

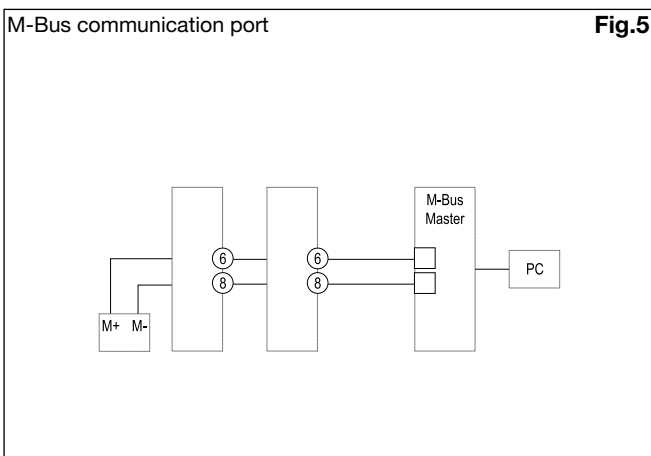
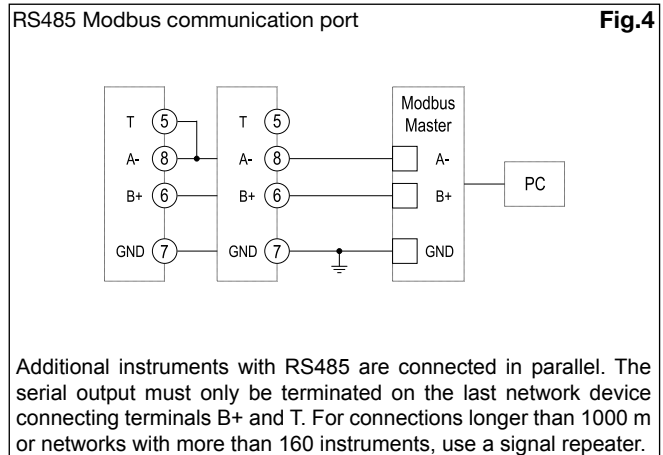
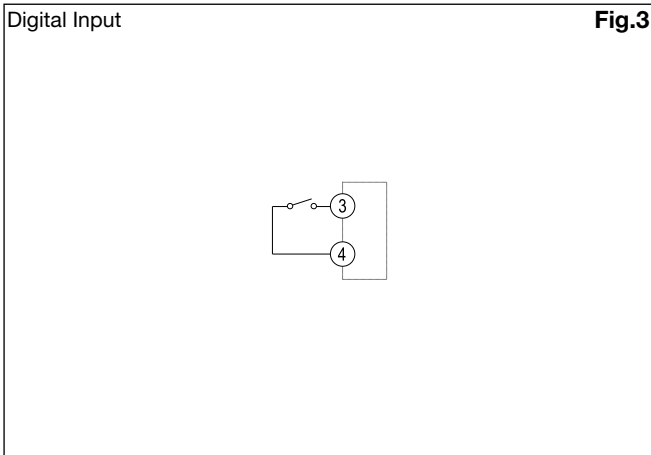
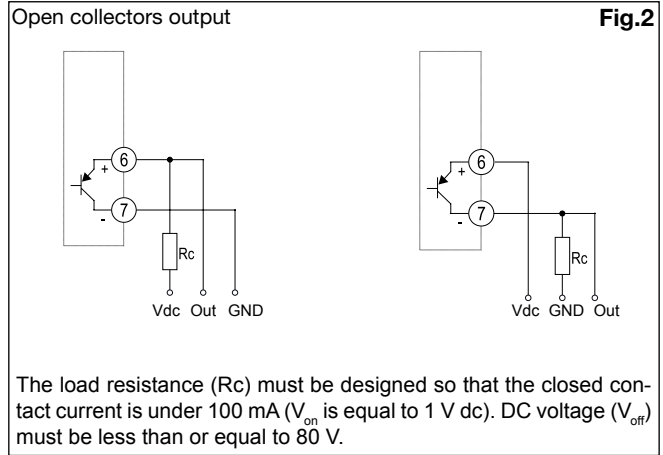
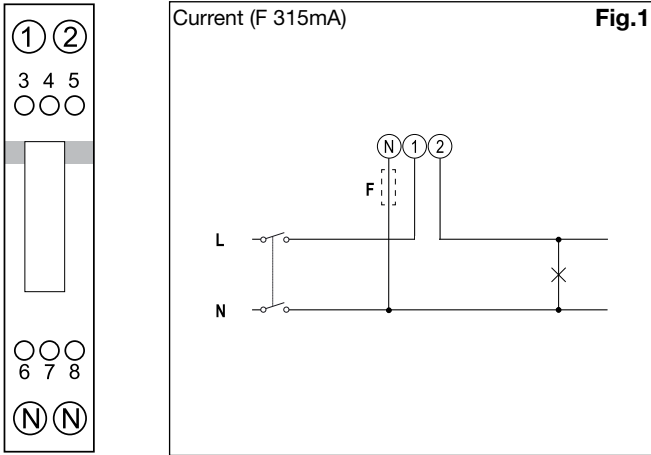



## Front panel description

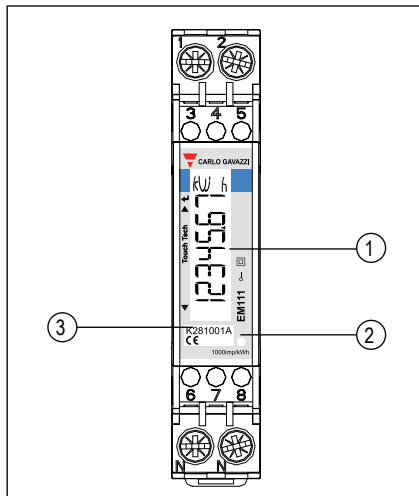

1. **Display**  
Backlit LCD display with touch key-pad.  
Upper part: enter  
Lower part: UP  
Scroll in up direction: UP  
Scroll in down direction: DOWN
2. **LED**  
LED proportional to kWh reading
3. **Serial number and MID data**  
Area reserved to serial number and MID-relevant data in PF versions

## Dimensions (mm)

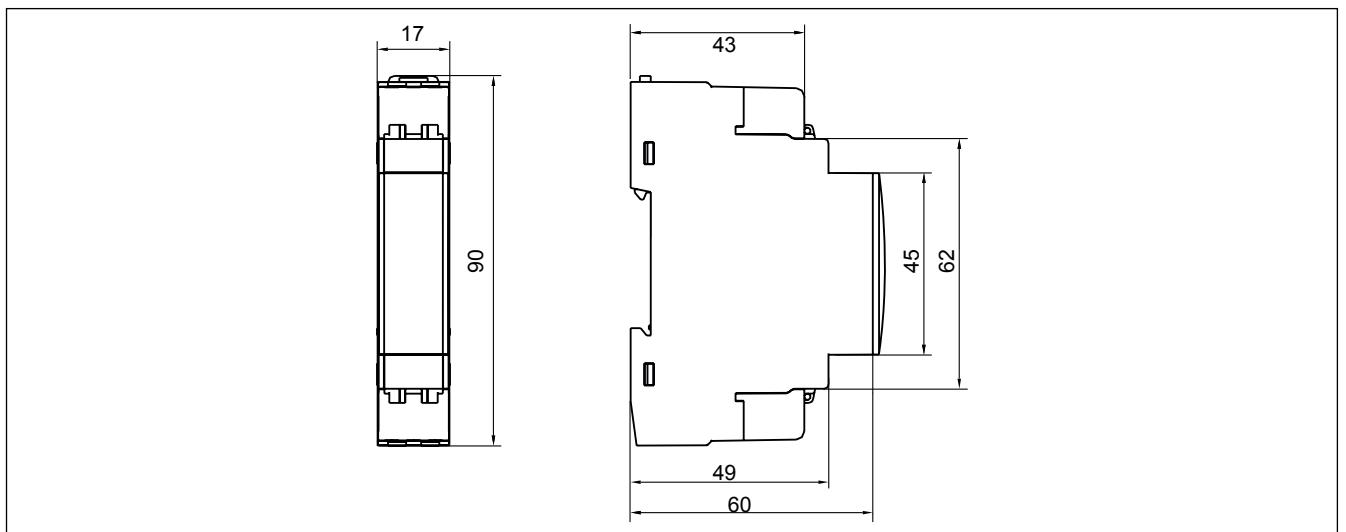

## X-ON Electronics

Largest Supplier of Electrical and Electronic Components

*Click to view similar products for Carlo Gavazzi manufacturer:*

Other Similar products are found below :

[CTD10S16005AXXX](#) [MC485232](#) [FPD01SBS200](#) [FPD06SCC200](#) [FPT01SBS200](#) [MP3100](#) [PD30CNG02NPM5RT](#) [PD30CNG02PPM5MU](#)  
[PD30CNP06NPM5DU](#) [PD30CNP06PPM5DU](#) [PIB01CB2350MA](#) [PIB01CB235A](#) [G21205502700](#) [G21960005700](#) [G34296470800](#)  
[G34304443115](#) [G34396470115](#) [G34960003700](#) [G38000016230](#) [G88301143](#) [G89111010](#) [GAD1213024](#) [GH34850000724](#) [PMT20IM](#) [GMS-](#)  
[63H-50A](#) [GP67630107](#) [PPA01CM44](#) [PPB01CM23N](#) [PPC01DM23](#) [PPC01DM48](#) [PS21R-NT11N7-YK0](#) [GS38300143230](#) [GT225S100A](#)  
[GT400S400A](#) [GT63L10A](#) [GT63L40A](#) [GT63S18A](#) [GT800S800A](#) [PUC01CB23500V](#) [A208024060](#) [GTU8](#) [A82-10100](#) [A82-20500](#)  
[RA2325H06POS](#) [RA4825H12NOS](#) [RAP48A3](#) [AD2000](#) [DAC01CM40](#) [RCP800224VDC](#) [REC2R48D30GKE](#)