

MC10808A6W-SPR-V2	1 x 1	1 mm Character Height	LCD Module
Specification			
Version: 1		Date: 29/09/2016	
Revision			

Display Features	
Operating Temp. Range	-20°C - +70°C
Viewing Direction	6 O'Clock
STN	Yellow/Green
Backlight	N/A
Controller	U-111
Characters	1 x 1
Voltage	5V
Module Size	69.00 x 27.00 x 8.00 mm
Character Height	8mm
Display Construction	Chip on Board



Box Quantity	Weight / Display
45pcs	35.55 grams

* - For full design functionality, please use this specification in conjunction with the Sunplus specification. (Provided Separately)

Optional Variants			Display Accessories	
Fonts	Physical Aspects	Voltage	Part Number	Description
English/Japanese	N/A	N/A	MCCMDB-16SIL	LCD interconnect board, can be driven from either a PC or a single board computer with a USB output.

Mechanical Specifications

Module Size	69.00 x 27.00 x 8.00 (Without Backlight)				W x H x D mm
Viewing Area	45.20 x 13.80	W x H mm	Hole-to-Hole	65.40	W x H mm
Character Size	4.20 x 7.71	W x H mm	Character Pitch	1.00	W mm
Dot Size	$\text{€}80 \times 0.92$	W x H mm	Dot Pitch	0.05 x 0.05	W x H mm

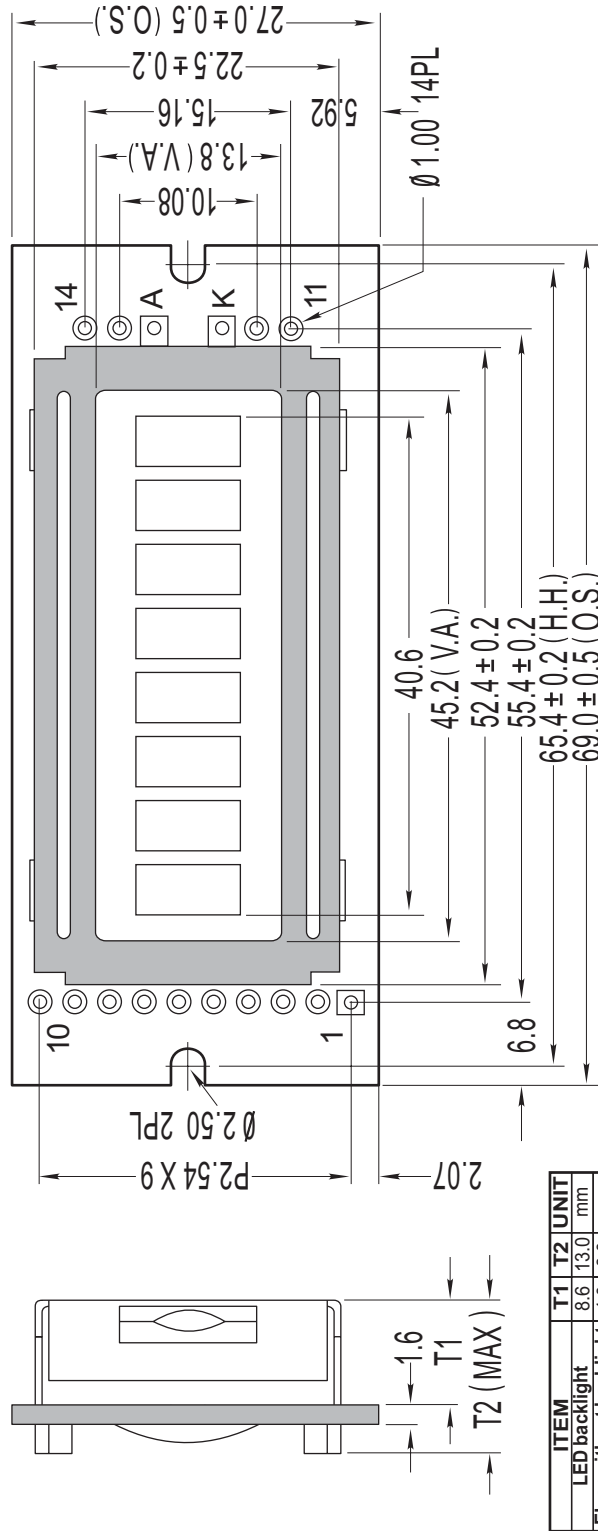

MC10808A6W-SPR-V2	1 x 8	8mm Character Height	LCD Module
Specification			
Version: 1		Date: 29/09/2016	
Revision			

Pin Layout

PI	SYMBOL	DESCRIPTION	REMARKS
1	Vss	GND	
2	Vdd	Power supply for LCM	5.0V
3	V0	Contrast Adjust	
4	RS	Register Select Signal	
5	R/W	Data Read /Write	
6	E	Enable Signal	
7	DB4	Data bus line	
8	DB5	Data bus line	
9	DB6	Data bus line	
10	DB7	Data bus line	
11	DB0	Data bus line	
12	DB1	Data bus line	
13	DB2	Data bus line	
14	DB3	Data bus line	
15	NC	No Connection	
16	NC	No Connection	

Block Diagram

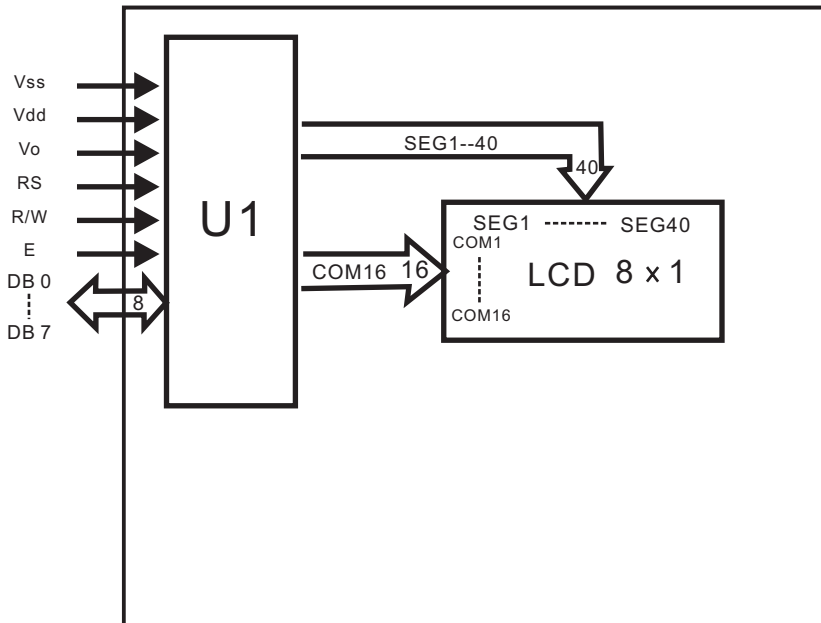

Power Supply Diagram

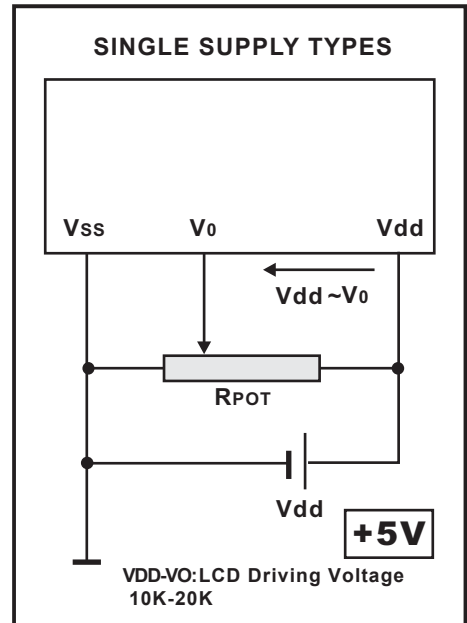

MC10808A6W-SPR-V2	1 x 8	8mm Character Height	LCD Module
Specification			
Version: 1		Date: 29/09/2016	
Revision			

Font Map

Upper 4bit Lower 4bit	LLLL	LLLH	LLHL	LLHH	LHLL	LHLH	LHHL	LHHH	HLLL	HLLH	HLHL	HLHH	HHLL	HHLH	HHHL	HHHH
LLLL	CG RAM (1)															
LLLH	(2)															
LLHL	(3)															
LLHH	(4)															
LHLL	(5)															
LHLH	(6)															
LHHL	(7)															
LHHH	(8)															
HLLL	(1)															
HLLH	(2)															
HLHL	(3)															
HLHH	(4)															
HHLL	(5)															
HHLH	(6)															
HHHL	(7)															
HHHH	(8)															

MC10808A6W-SPR-V2	1 x 8	8mm Character Height	LCD Module
Specification			
Version: 1	Date: 29/09/2016		
Revision			

Absolute Maximum Ratings						
Item	Symbol	Condition	Min	Typ	Max	Unit
Power Supply (LOGIC)	Vdd	25°C	-0.3	---	7.0	V
Power Supply (LCD)	V0	25°C	Vdd -13.5	---	Vdd +0.3	V
Input Voltage	Vin	25°C	-0.3	---	Vdd +0.3	V
Operating Temperature	Vopr	---	-20	---	70	°C
Storage Temperature	Vstg	---	-30	---	80	°C

Electronic Characteristics						
Item	Symbol	Condition	Min	Typ	Max	Unit
Input Voltage	Vlcm = Vdd	+5V	4.7	5.0	5.5	v
Supply Current	Idd	Vdd=5V	---	1.3	---	mA
Driving Voltage for LCD Panel	Vlcd = (Vdd - V0)	-20 °C	4.50	---	4.80	v
		0 °C	4.35	---	4.75	
		25 °C	4.30	4.45	4.70	
		50 °C	4.20	---	4.60	
		70 °C	4.00	---	4.50	

LCD Characteristics						
For STN/FSTN LCD Panel Types						
Item	Symbol	Condition	Min	Typ	Max	Unit
Viewing Angle	$\Phi 2 - \Phi 1$	K = 4	40°	---	---	Deg
	Θ		60°			
Contrast Ratio	K	---	---	6	---	---
Response Time (Rise)	TR	---	---	150	250	ms
Response Time (Fall)	TF	---	---	150	250	ms

MC10808A6W-SPR-V2	1 x 8	8mm Character Height	LCD Module
Specification			
Version: 1		Date: 29/09/2016	
Revision			

X-ON Electronics

Largest Supplier of Electrical and Electronic Components

Click to view similar products for [Midas](#) manufacturer:

Other Similar products are found below :

[MCT070LA12W1024600LML](#) [MCT043C0TW480272LML](#) [MCOB21609AV-EWP](#) [MC42004A6W-SPTLY](#) [MC22008B6W-SPR](#)
[MC21609A12W-VNMLG](#) [MC22005A12W-VNMLY](#) [MCT035G12W320240LML](#) [MC21605A6WR-BNMLW-V2](#) [MC21605C6W-FPTLA-V2](#)
[MC21605DA6W-SPTLY-V2](#) [MC21605H6W-BNMLW-V2](#) [MC42005A6W-FPTLW3-V2](#) [MCOT128064QV-WM](#) [MCOT048064A1V-YI](#)
[MCOT128064E1V-BM](#) [MCOT096016C1V-BI](#) [MCT101E0CW1280800LMLIPS](#) [MCT039C12CW480128LML](#) [MCCOG240064F6W-FPTLW](#)
[MC240064GD6W-BNMLW](#) [MCT070Z0W800480LML](#) [MCOT128064EY-YM](#) [MCIB-7](#) [MC21605A6WK-FPTLW-V2](#) [MC21605C6W-](#)
[FPTLW-V2](#) [MC22005A6WK-SPTLY-V2](#) [MC22005A6WR-SPTLY-V2](#) [MC41605A6W-FPTLA-V2](#) [MC42005A6W-BNMLW-V2](#)
[MC128064E6W-FPTLW-V2](#) [MCOT128064U1V-BM](#) [MCT150B0W1024768LML](#) [MCCOG240064D6W-FPTLW](#)
[MCT070Z0TW1W800480LML](#) [MCT050ACA0CW800480LML](#) [MCOT128064BY-WM](#) [MC11605A12W-VNMLB](#)
[MCT052A6W480128LML](#) [MC11605A6WR-SPTLY-V2](#) [MC11606A6W-SPTLY-V2](#) [MC21605AB6W-GPTLY-V2](#) [MC21605G6WR-](#)
[FPTLW-V2](#) [MC24005A6W-BNMLW-V2](#) [MC128064C6W-FPTLW-V2](#) [MC42005A6W-BNMLWI-V2](#) [MCOB21605GX-EGP](#)
[MCOT128064UA1V-WM](#) [MCOT256064A1A-BM](#) [MCOT22005A1V-EYM](#)