

MC41605B6W-SPTLY-V2	4 x 16	5mm Character Height	LCD Module
Specification			
Version: 1		Date: 20/10/2016	
Revision			

Display Features	
Operating Temp. Range	-20°C ~ +70°C
Viewing Direction	6 O'Clock
STN	Yellow/Green Transflective
Backlight	LED Yellow/Green
Controller	Sunplus
Characters	4 x 16
Voltage	5V
Module Size	72.00 x 48.00 x 13.60 mm
Character Height	5mm
Display Construction	Chip on Board



Box Quantity	Weight / Display
30 pcs	75 grams

* - For full design functionality, please use this specification in conjunction with the SPLC780D specification. (Provided Separately)

Optional Variants			Display Accessories	
Fonts	Physical Aspects	Voltage	Part Number	Description
English/Japanese	N/A	N/A	MCCMDB-16SIL	LCD interconnect board, can be driven from either a PC or a single board computer with a USB output.
			MCCBL1A16SILP-16DILS-150	16 Way, Single in-line to Dual In-line connector Cable.
			MCCBL1A16SILP-16SILS-150	16 Way, Single in-line to Single In-line connector Cable.

Mechanical Specifications

Module Size	72.00 x 48.00 x 13.60 (With Backlight)				W x H x D mm
Viewing Area	61.80 x 25.20	W x H mm	Hole-to-Hole	67.00 x 44.00	W x H mm
Character Size	2.96 x 4.76	W x H mm	Character Pitch	0.59 x 0.59	W x H mm
Dot Size	0.56 x 0.56	W x H mm	Dot Pitch	0.04 x 0.04	W x H mm

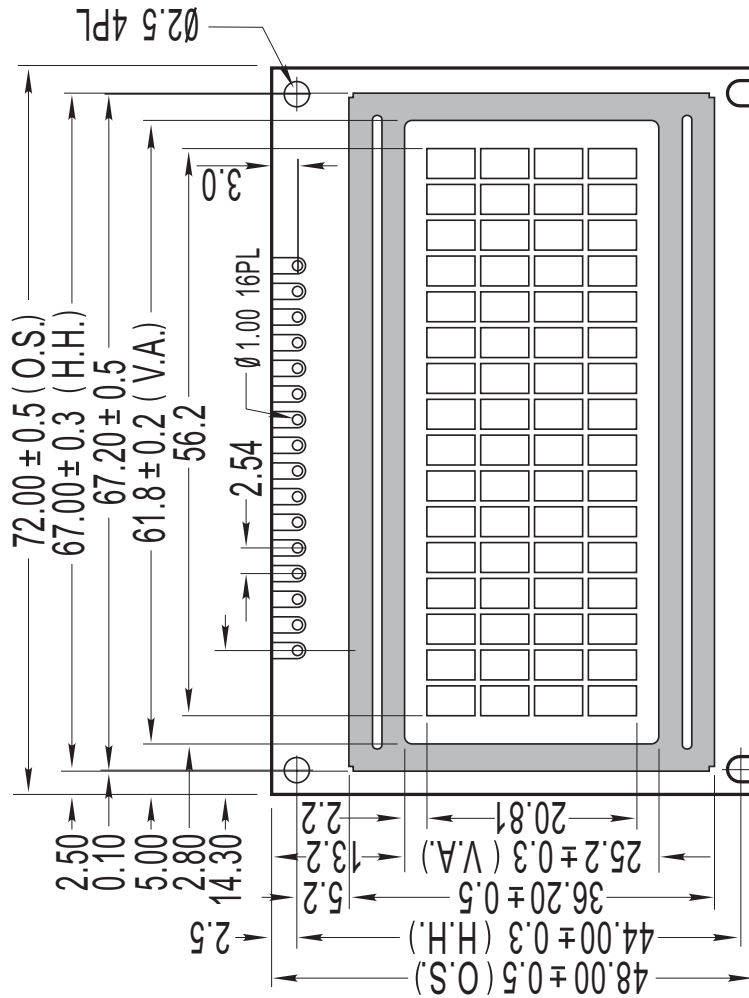

ITEM	T1	T2	UNIT
LED backlight	9.0	13.6	mm
EL or without backlight	4.6	9.5	mm

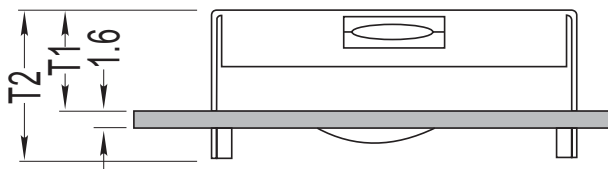

MC41605B6W-SPTLY-V2	4 x 16	5mm Character Height	LCD Module
Specification			
Version: 1		Date: 20/10/2016	
Revision			

Pin Layout

PI	SYMBOL	DESCRIPTION	REMARKS
1	Vss	GND	
2	Vdd	Power supply for LCM	5.0V
3	V0	Contrast Adjust	
4	RS	Register Select Signal	
5	R/W	Data Read / Write	
6	E	Enable Signal	
7	DB0	Data bus line	
8	DB1	Data bus line	
9	DB2	Data bus line	
10	DB3	Data bus line	
11	DB4	Data bus line	
12	DB5	Data bus line	
13	DB6	Data bus line	
14	DB7	Data bus line	
15	LED+	Power supply for BKL	5.0V
16	LED-	Power supply for BKL	0V

Block Diagram

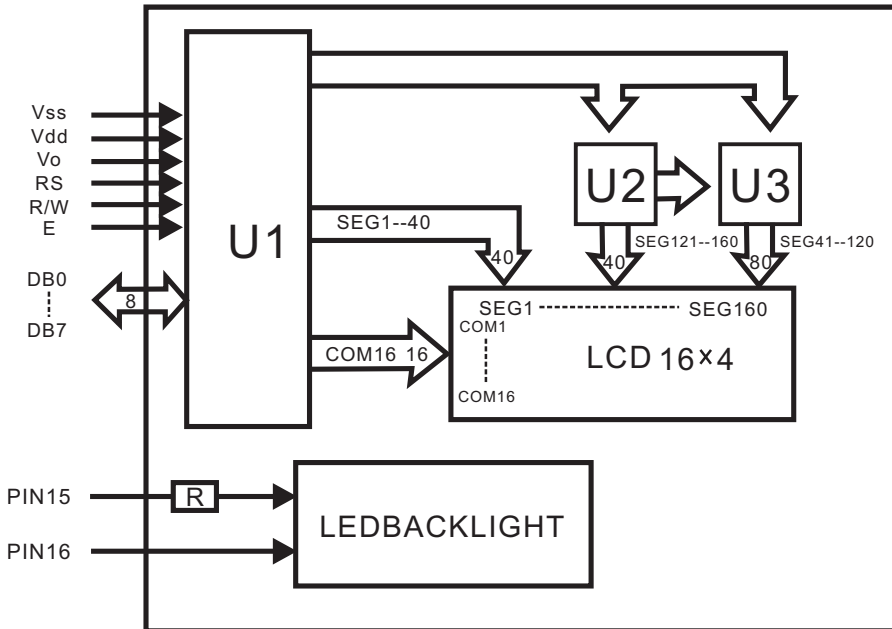

Power Supply Diagram

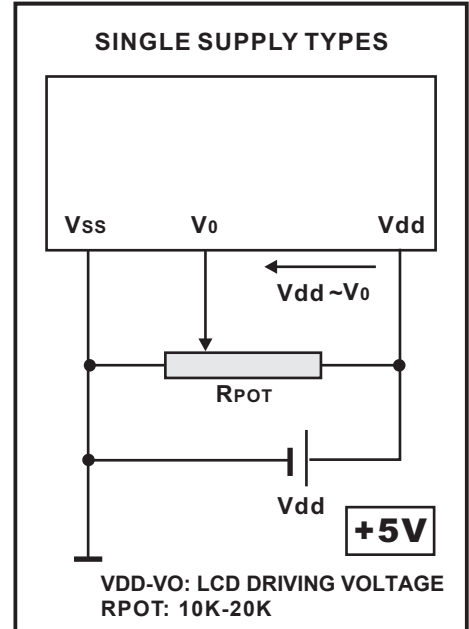

MC41605B6W-SPTLY-V2	4 x 16	5mm Character Height	LCD Module
Specification			
Version: 1		Date: 20/10/2016	
Revision			

Font Map

Upper 4bit Lower 4bit	LLLL	LLLH	LLHL	LLHH	LHLL	LHLH	LHHL	LHHH	HLLL	HLLH	HLHL	HLHH	HHLL	HHLH	HHHL	HHHH	
LLLL	CG RAM (1)																
LLLH	(2)																
LLHL	(3)																
LLHH	(4)																
LHLL	(5)																
LHLH	(6)																
LHHL	(7)																
LHHH	(8)																
HLLL	(1)																
HLLH	(2)																
HLHL	(3)																
HLHH	(4)																
HHLL	(5)																
HHLH	(6)																
HHHL	(7)																
HHHH	(8)																

MC41605B6W-SPTLY-V2	4 x 16	5mm Character Height	LCD Module
Specification			
Version: 1		Date: 20/10/2016	
Revision			

Absolute Maximum Ratings						
Item	Symbol	Condition	Min	Typ	Max	Unit
Power Supply (LOGIC)	Vdd	25°C	-0.3	---	7.0	V
Power Supply (LCD)	V0	25°C	Vdd -13.5	---	Vdd +0.3	V
Input Voltage	Vin	25°C	-0.3	---	Vdd +0.3	V
Operating Temperature	Vopr	---	-20	---	70	C
Storage Temperature	Vstg	---	-30	---	80	C

Electronic Characteristics						
Item	Symbol	Condition	Min	Typ	Max	Unit
Input Voltage	Vlcm = Vdd	---	4.7	5.0	5.5	v
Supply Current	Idd	Vdd=5V	---	1.4	---	mA
Driving Voltage for LCD Panel	Vlcd = (Vdd - V0)	-20°C	4.40	---	4.90	v
		0°C	4.30	---	4.80	
		25°C	4.25	4.50	4.75	
		50°C	4.20	---	4.70	
		70°C	4.05	---	4.55	

LCD Characteristics						
For STN/FSTN LCD Panel Types						
Item	Symbol	Condition	Min	Typ	Max	Unit
Viewing Angle	$\Phi 2 - \Phi 1$	K = 4	40°	---	---	Deg
	Θ		60°			
Contrast Ratio	K	---	---	10	---	---
Response Time (Rise)	TR	---	---	150	250	ms
Response Time (Fall)	TF	---	---	150	250	ms

LED Characteristics						
Item	Symbol	Condition	Min	Typ	Max	Unit
LED Forward Voltage	Vf	25°C	3.8	---	4.4	V
LED Forward Current*	If	25°C	---	150	---	mA
LED Reverse Current	Ir	25°C	---	---	150	mA
LED Peak Wave Length	λp	25°C If=150mA	568	---	575	nm
LED Brightness (Without LCD)	Lv	25°C If=150mA	125	180	200	cd/m ²
LED Life Time	---	25°C If=150mA	9K	---	---	Hours

Attention: It is constant current, not constant voltage, which should be applied when driving the LED backlight, please ensure you adhere to this rule.

MC41605B6W-SPTLY-V2	4 x 16	5mm Character Height	LCD Module
Specification			
Version: 1		Date: 20/10/2016	
Revision			

X-ON Electronics

Largest Supplier of Electrical and Electronic Components

Click to view similar products for [Midas](#) manufacturer:

Other Similar products are found below :

[MCT070LA12W1024600LML](#) [MCT043C0TW480272LML](#) [MCOB21609AV-EWP](#) [MC42004A6W-SPTLY](#) [MC22008B6W-SPR](#)
[MC21609A12W-VNMLG](#) [MC22005A12W-VNMLY](#) [MCT035G12W320240LML](#) [MC21605A6WR-BNMLW-V2](#) [MC21605C6W-FPTLA-V2](#)
[MC21605DA6W-SPTLY-V2](#) [MC21605H6W-BNMLW-V2](#) [MC42005A6W-FPTLW3-V2](#) [MCOT128064QV-WM](#) [MCOT048064A1V-YI](#)
[MCOT128064E1V-BM](#) [MCOT096016C1V-BI](#) [MCT101E0CW1280800LMLIPS](#) [MCT039C12CW480128LML](#) [MCCOG240064F6W-FPTLW](#)
[MC240064GD6W-BNMLW](#) [MCT070Z0W800480LML](#) [MCOT128064EY-YM](#) [MCIB-7](#) [MC21605A6WK-FPTLW-V2](#) [MC21605C6W-](#)
[FPTLW-V2](#) [MC22005A6WK-SPTLY-V2](#) [MC22005A6WR-SPTLY-V2](#) [MC41605A6W-FPTLA-V2](#) [MC42005A6W-BNMLW-V2](#)
[MC128064E6W-FPTLW-V2](#) [MCOT128064U1V-BM](#) [MCT150B0W1024768LML](#) [MCCOG240064D6W-FPTLW](#)
[MCT070Z0TW1W800480LML](#) [MCT050ACA0CW800480LML](#) [MCOT128064BY-WM](#) [MC11605A12W-VNMLB](#)
[MCT052A6W480128LML](#) [MC11605A6WR-SPTLY-V2](#) [MC11606A6W-SPTLY-V2](#) [MC21605AB6W-GPTLY-V2](#) [MC21605G6WR-](#)
[FPTLW-V2](#) [MC24005A6W-BNMLW-V2](#) [MC128064C6W-FPTLW-V2](#) [MC42005A6W-BNMLWI-V2](#) [MCOB21605GX-EGP](#)
[MCOT128064UA1V-WM](#) [MCOT256064A1A-BM](#) [MCOT22005A1V-EYM](#)