



Ground Fault Current Detection Systems

Model BGFL (Relay)

Trip Currents 5- 60, 30- 360, or 100 -1200A



OPERATING RANGE:

Trip currents of 5-60, 30-360, or 100-1200A. Time delay from 0.10 to 1 second. (Adjustable)

INPUT POWER:

2 VA plus shunt coil requirements. Rated @ 120 Vac.

INPUT WITHSTAND:

200,000 Amperes RMS for 3 cycles, 50/60 Hz.

NOMINAL INPUT VOLTAGE:

120 Volts ac, 125 Volts dc, 24 Volts dc, 48 Volts dc.

FREQUENCY:

50/60 Hz.

AMBIENT TEMPERATURE RANGE:

-30°C to +60°C

Only for use with GFL sensors.

Approximate weight 1.5 lbs.

These Class 1 Model **BGFL** Ground Fault Relays and Sensors are designed to form a system for detecting a ground fault current on a ground ac power system. When a ground fault exceeds a pre-selected Current level and Time Delay setting, the relay initiates a trip signal for a shunt trip disconnect device to open and clear the fault. This **BGFL** system is designed to provide protection for electrical equipment, not protection for personnel.

- Meets NEC service entrance equipment standards.
- Available in three basic styles, "Standard", "Form C", or "Zone Interlocking" for coordination of single or multiple ground fault devices in system.
- Integral test panel with Push To Test and Shunt Trip Bypass pushing for ease in proper operational testing of the system, with or without tripping the protective device.
- "Power On" LED indicator in cover.
- Positive visual trip indicator, manual reset.
- Infinitely adjustable Time Delay.
- Discrete current threshold adjustment.
- Panel or door mounting.
- Rear terminal kit and clear plastic cover standard with door mounting.
- Electromechanical relay output, positive "ON" and "OFF".
- Operates with molded case and power circuit breakers, bolted pressure switches, fusible disconnect switches.

CONTACT RATING		
DEVICE INPUT POWER	INRUSH	CONT.
120 Volts ac	10 A	3 A
125 Volts dc	1 A	1 A
48 Volts dc	4 A	4 A
24 Volts dc	8 A	8 A

HOW TO ORDER RELAYS

Aux. Supply Voltage
 5=120V ac, 50/60Hz
 4=125V dc
 3=24V dc
 2=48V dc

Internal Circuit Options
 4=Isolated Internal "Form C" *
 7=With Zone Interlocking
 9=Without Zone Interlocking

BGFL X X X - XXXX

Mounting
 1=Panel mount
 2=Door mount

Current Range
 60=5 to 60A
 360=30 to 360A
 1200=100 to 1200A

* Not Available with zone Interlocking option

Ground Fault Current Detection Systems

Model BGFL (Outlines)

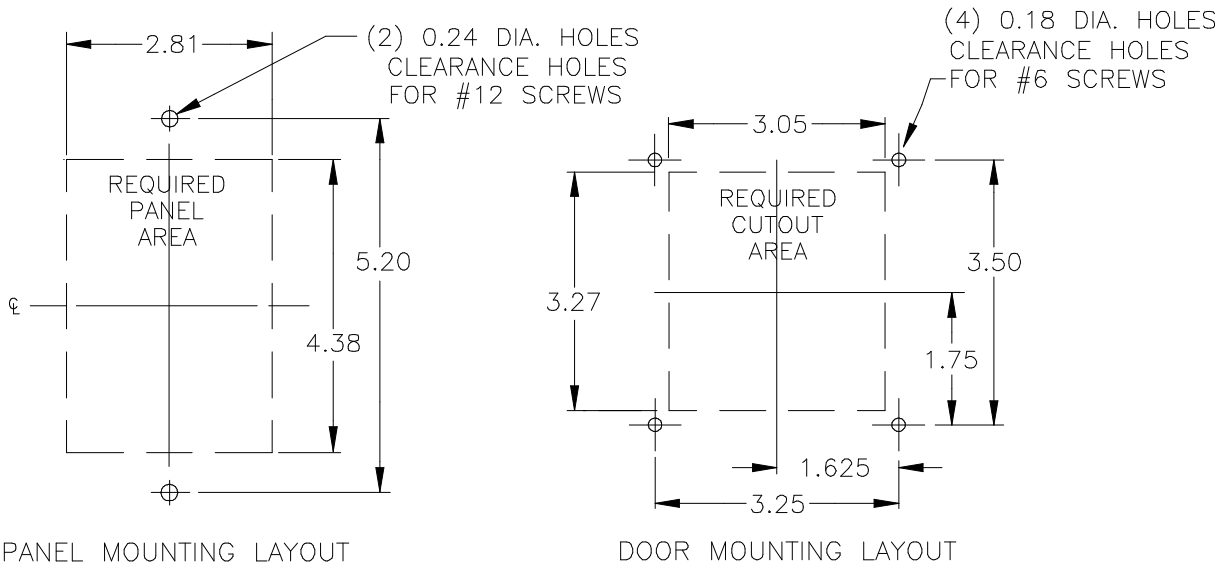
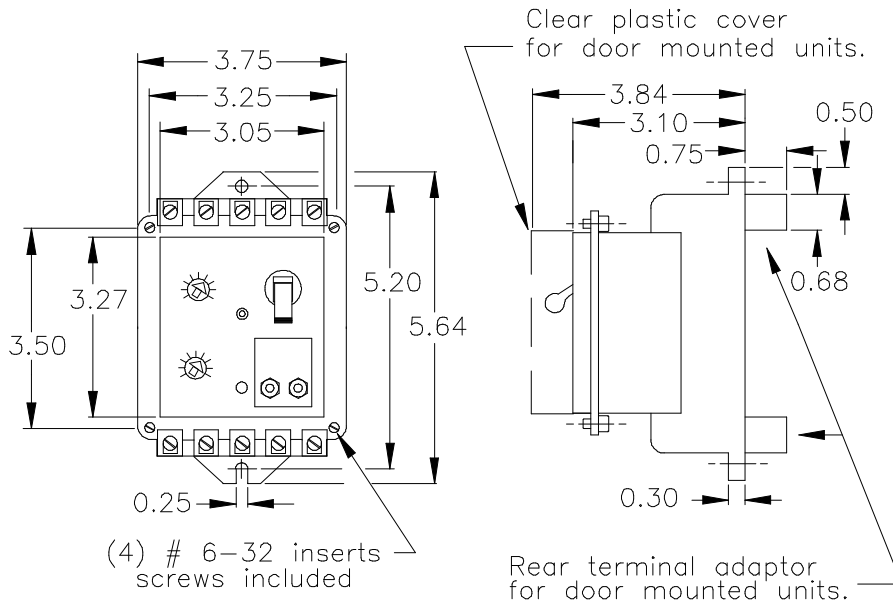

USA, Canada, Asia, Latin America

Tel: +1-800-547-8629

Fax: +1-905-201-2455

e-mail: sales.multilin@ge.com

Europe, Middle East, Africa

Tel: +34-94-485-88-00

Fax: +34-94-485-88-45

e-mail: gmultilin.euro@ge.com



Ground Fault Current Detection Systems

Model GFL (Sensor)

Trip Currents 5- 60, 30- 360, or 100 -1200A



110395



LR80793

Ground Fault Current Sensors, type GFL, are available in three different styles, a variety of sizes and current ranges - to match the BGFL relay ranges. The physical size of the sensor window should be carefully determined by the physical size and configuration of the power conductors. The Ground Fault Sensor will respond only to ground faults which occur between the position of the sensor and the load. Each sensor has two sets of windings one for test and one for normal operation.



Toroidal Sensors

OPERATING RANGE:

Trip currents from 5- 60,
30-360, or 100-1200A.
Trip current tolerance ± 15 percent.

FREQUENCY:

50/60 Hz.

INSULATION LEVEL:

600 Volt, 10 kV BIL full wave.

Terminals are brass studs No. 8-32.

Only for use with BGFL relays.

MODEL NUMBER	SENSOR DIMENSIONS					
	"A1"	"A2"	"A3"	"B1"	"B2"	"B3"

TRIP CURRENT 5-60 AMPS

GFL156T-1	1.56	*	3.53	*	3.77	2.15
GFL250T-1	2.50	*	4.56	*	4.71	2.13
GFL325T-1	3.25	4.70	5.73	4.70	5.73	1.15
GFL425T-1	4.25	4.86	5.92	**	6.17	1.15
GFL631T-1	6.31	6.75	8.50	6.75	8.50	1.28
GFL825T-1	8.25	8.50	10.48	8.50	10.48	1.53

TRIP CURRENT 30-360 AMPS

GFL156T-3	1.56	*	3.53	*	3.77	2.15
GFL250T-3	2.50	*	4.56	*	4.71	2.13
GFL325T-3	3.25	4.70	5.73	4.70	5.73	1.15
GFL425T-3	4.25	4.86	5.92	**	6.17	1.15
GFL631T-3	6.31	6.75	8.50	6.75	8.50	1.28
GFL825T-3	8.25	8.50	10.48	8.50	10.48	1.53

TRIP CURRENT 100-1200 AMPS

GFL325T-2	3.25	4.70	5.73	4.70	5.73	1.15
GFL425T-2	4.25	4.86	5.92	**	6.17	1.15
GFL631T-2	6.31	6.75	8.50	6.75	8.50	1.28
GFL825T-2	8.25	8.50	10.48	8.50	10.48	1.53

* The Model GFL156T-1, GFL156T-3, GFL250T-1, and GFL250T-3 have molded mounting feet.

** The Models GFL425T-1, GFL425T-2, and GFL425T-3 have no top mounting holes. Order the following mounting bracket kits:

MODEL NUMBER	BRACKET KIT
GFL 325T-1, -2 and -3	0221B00183
GFL 425T-1, -2 and -3	0221B00183
GFL 631T-1, -2 and -3	0221B00231
GFL 825T-1, -2 and -3	0221B01529

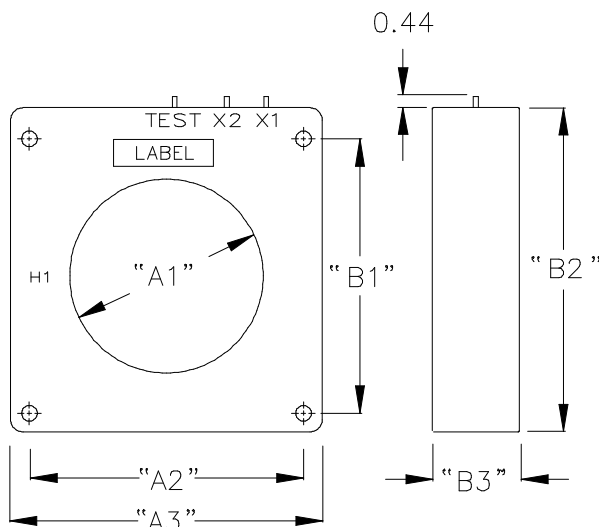

Ground Fault Current Detection Systems

Model GFL (Sensor)

Trip Currents 5-60, 30-360, or 100-1200A

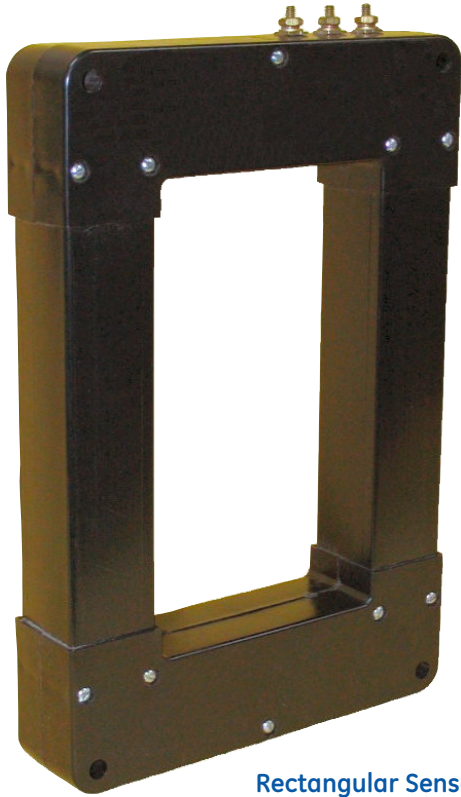

Rectangular Sensors

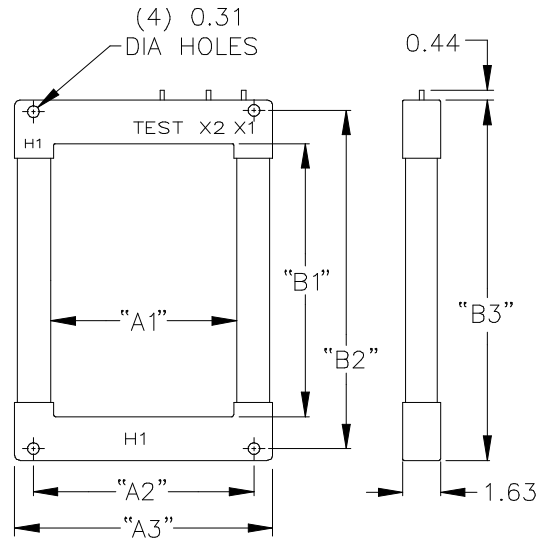

RECTANGULAR SENSORS					
"A1"	"A2"	"A3"	"B1"	"B2"	"B3"
4.1	6.4	7.3	7.1	10.0	10.9
5.1	7.2	8.3	11.7	14.5	15.4
5.8	7.0	9.0	14.1	17.0	17.9
8.0	9.5	11.1	18.1	21.0	21.9
10.1	11.6	13.2	24.0	27.0	27.9
-	-	-	30.1	33.0	33.9
-	-	-	36.0	38.9	39.8

Rectangular sensors are available for the following trip currents: 5-60A, 30-360A and 100-1200A. The table above lists the available sensors sizes. Any window width (A1) may be combined with any window length. (B1)

Rectangular sensors are also available as a split core (take-apart) style for assembly to existing electrical installation without the need for dismantling the primary bus or cables.

CAUTION:

Proper safety precautions must be followed during installation by a trained electrician. It is recommended that the incoming power de-energized before installation. The sensor must have its secondary terminals short circuited or the relay connected, before energizing the primary circuit.

HOW TO ORDER RECTANGULAR SENSORS

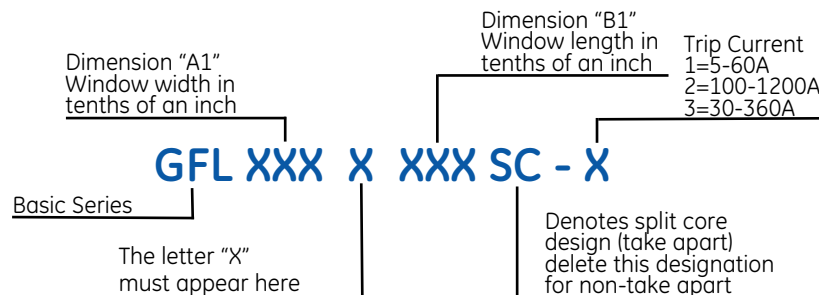

Example: To order a rectangular sensor with a 4.1 X 7.1 window and a 5-60A trip current, the catalog number would be GFL 041 X 071-1.

USA, Canada, Asia, Latin America

Tel: +1-800-547-8629

Fax: +1-905-201-2455

e-mail: sales.multilin@ge.com

Europe, Middle East, Africa

Tel: +34-94-485-88-00

Fax: +34-94-485-88-45

e-mail: gemultilin.euro@ge.com

Typical Response Curves

Cardinal points are shown for clarity only.

The actual time delay adjustment is continuously variable between instantaneous and 1 second. The time delay tolerance is $\pm 15\%$ of setting.

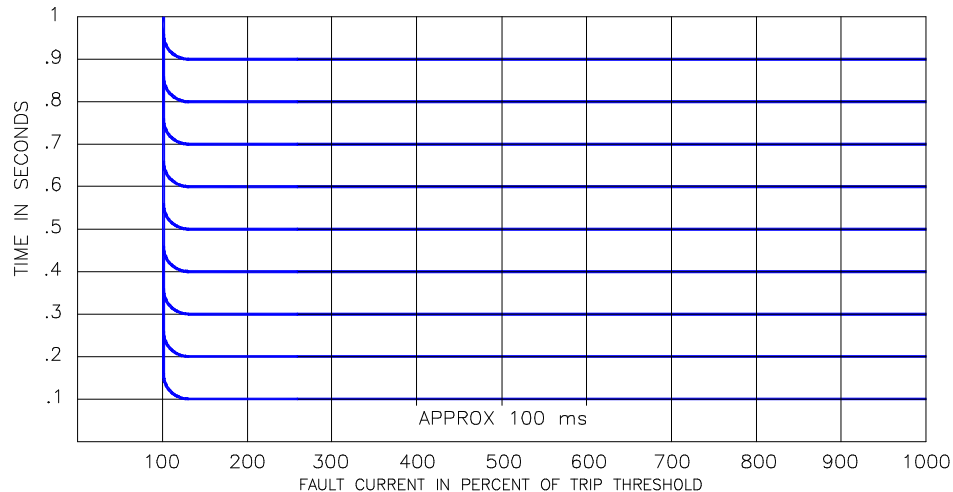

Test Procedure

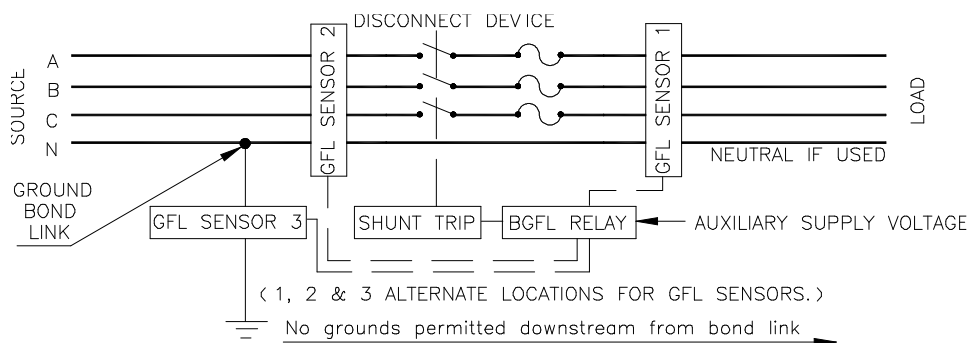

To determine if the neutral is grounded in only one place at the service entrance (in accordance with The National Electrical Code):

1. Disconnect power.
2. Remove ground bond link.
3. With a "megger", measure the resistance of each phase and neutral to ground. The resistance should be 1 megohm in accordance with NEC requirements. Reading as low as 100 ohms will pass a minimal current so as not to affect **BGFL** calibration on the 100 - 1200A relay. The 5-60A and 30-360A relay calibration will be affected if set at the lowest setting.
4. Reconnect bond link, reconnect power and check power LED for illumination.

To test the entire system including the disconnect device:

1. Check for control power, the LED should be illuminated.
2. Press the "Push To Test" switch on the relay. The trip indicator will go to the tripped position and disconnect device will open.
3. Reset the relay and the disconnect device. System is now back to normal.

To test the ground Fault Relay and Sensor only (The sensor will trip the relay in this test).

1. Check for control power, the LED should be illuminated.
2. Press and HOLD the "Shunt Trip Bypass" switch on the relay.
3. Press the "Push To Test" switch. The Ground Fault Relay will trip.
4. Reset the relay, then release the "Shunt Trip Bypass" switch. System is now back to normal.

THE ABOVE TEST PROCEDURES SHOULD BE PERFORMED BY QUALIFIED PERSONNEL ONLY.

Typical Wiring Diagrams

TYPICAL WIRING DIAGRAM FOR "STANDARD" AND "ZONE INTERLOCKING" CIRCUITRY (BGFLXX7-XXXX AND BGFLXX9-XXXX)

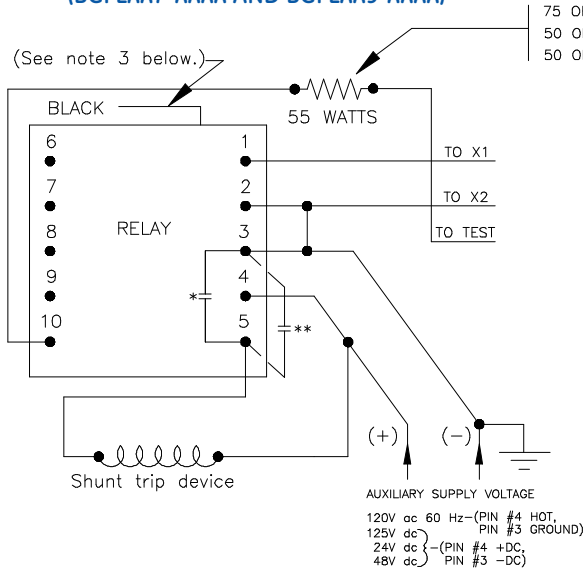

TYPICAL WIRING DIAGRAM FOR "FORM C" CIRCUITRY (BGFLXX4-XXXX)

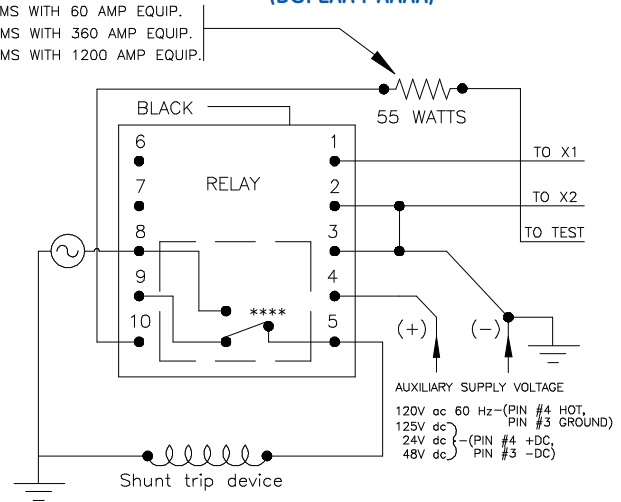

- * Internal BGFL Relay Contact
- ** Additional Protective Device. "NO" isolated contacts can be connected in parallel across terminals 3 and 5.
- *** Mounting provision on rectangular GFL sensors with 11.1" & 13.2" widths.
- **** Internal "FORM C" contact indicated in the relay "ON" position.

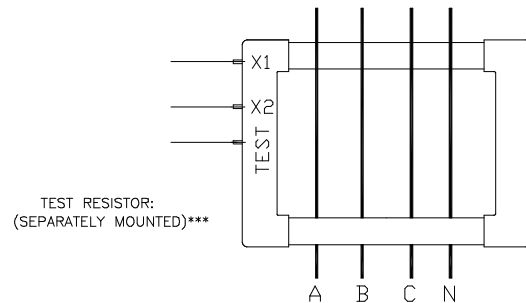

Typical Wiring Diagram Zone Selective Interlocking

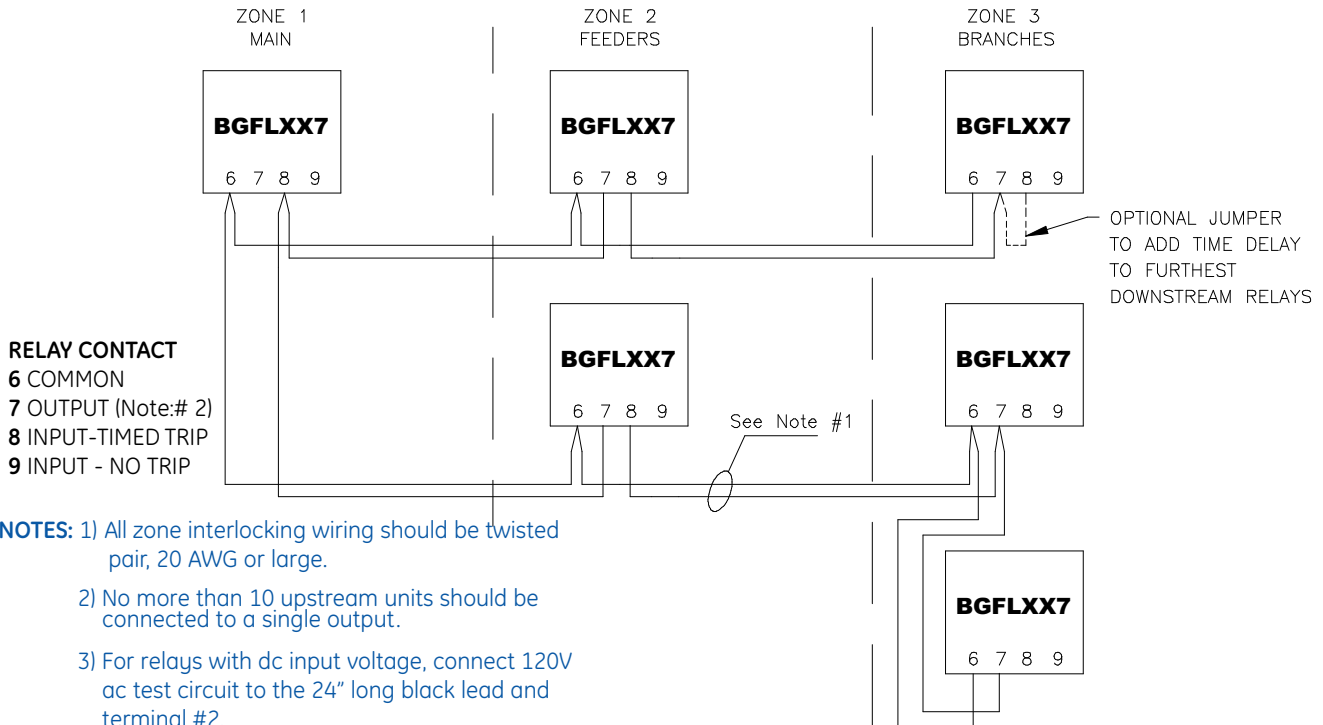

NOTES: 1) All zone interlocking wiring should be twisted pair, 20 AWG or large.

2) No more than 10 upstream units should be connected to a single output.

3) For relays with dc input voltage, connect 120V ac test circuit to the 24" long black lead and terminal #2.

USA, Canada, Asia, Latin America

Tel: +1-800-547-8629

Fax: +1-905-201-2455

e-mail: sales.multilin@ge.com

Europe, Middle East, Africa

Tel: +34-94-485-88-00

Fax: +34-94-485-88-45

e-mail: gemultilin.euro@ge.com

X-ON Electronics

Largest Supplier of Electrical and Electronic Components

Click to view similar products for [Eaton](#) manufacturer:

Other Similar products are found below :

[BK1-S506-2-R](#) [FHN31G1](#) [CH222B](#) [SAMI-2I](#) [SAMI-6I](#) [LPN-RK-25SP](#) [ZE6](#) [ZE9](#) [LPN-RK-15SP](#) [LPN-RK-3SP](#) [SAMI-1I](#) [2499](#) [GMC-500MA](#) [AT-20](#) [BK/SC-45](#) [AGC-1-2](#) [BK/MDA-15](#) [BK/MDA-1](#) [BK/C519-1A](#) [BK/MDL-3-2/10](#) [89096-015](#) [8943K28](#) [8946K153](#) [8961K155](#) [M22-DH-Y](#) [M22-DLH-Y](#) [M22-D-R-GB0/K11](#) [M22-LCH-R](#) [M22-L-R/R](#) [M22-WLK3-B](#) [63ET](#) [6422](#) [6580](#) [CTX20-16-52LP-R](#) [CWL530FI](#) [CXM/CO/GP/R/BB](#) [6HD36](#) [714125](#) [MBO-2](#) [7314K36](#) [7321K2](#) [ETF-200MA](#) [F02A-1-1/2A](#) [F02A-1-1/2AS](#) [F02A-1AS](#) [F02A-3/4A](#) [F03A250V10A](#) [F03A250V12A](#) [MDA-2-8/10-R](#) [MDA-30A](#)