

BOXER WH PEL

Polypropylene tool trolley



General features

- chromed handle (mod. Euro Boxer excluded)
- central lock with key (mod. Euro Boxer excluded)
- 2 side closing
- document area
- metal lid support stay (mod. Euro Boxer excluded)

Features

- 2 tool pallets with elastics
- bottom area with removable dividers
- telescopic handle
- wheels on ball bearings
- 2 small component boxes

Versions

- BOXER PEL
- BOXER PTS
- BOXER EURO BOXER
- BOXER WH PEL
- BOXER WH PTS

EAN

8024482175652



Technical features	A	B	C	D	E
mm internal dimensions	430	320	190	80	110
	Weight Kg 4,60				
inc internal dimensions	16 15/16	12 5/8	7 1/2	3 1/8	4 5/16
	Weight lbs 10.14				

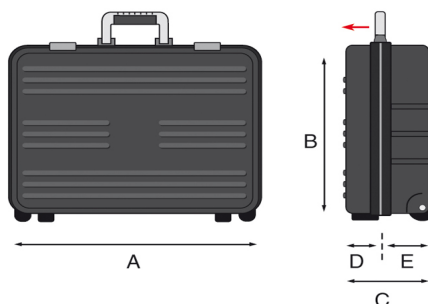

BOXER WH PEL

Polypropylene tool trolley



Polypropylene case realized with the injection molding technique. It has a modern design, with compact dimensions, high capacity and lightweight. The aluminium profile grants a further strength.

Accessories

BOXER WH PEL



LOCK BELT



WL01



WL02



WL03



WL04



WL05

X-ON Electronics

Largest Supplier of Electrical and Electronic Components

Click to view similar products for [Gt Line manufacturer](#):

Other Similar products are found below :

[REVO PEL](#) [3317.B](#) [3818.B](#) [TOP08 L](#) [3005.B](#) [1908.B](#) [5822.B](#) [NEW M. WHEELS PTS](#) [5221.B](#) [TOP10N](#) [TOP SMART N](#) [TOP BELT N](#)
[TOP 04](#) [BOXER WH PEL](#) [BOXER WH PTS](#) [WL 01](#) [WL 02](#)