

COMPACT™ PENDANT ARM SERIES 2, TYPE 12



APPLICATION

COMPACT™ Series 2 Pendant Arms allow operators to easily move controls into and out of position as needed, and they are easily mounted to a machine, wall or floor. Offering both superior load-bearing capacity and functional reliability, the COMPACT Series 2 Pendant Arm has a maximum load of 101 lb. (45.8 kg) at 3.3 ft. (1 m) and is recommended for use with INLINE™, CC2000, CC4000 and CONCEPT™ HMI enclosures as well as Consolets.

SPECIFICATIONS

- Cast aluminum couplings and extruded aluminum tubing. Series components provide excellent structural strength.
- Multiple coupling types and three standard tube lengths (500, 1000 and 1500 mm) combine to form numerous configurations as conduits for equipment wiring (see configuration guide)
- Removable access plates simplify cable installation inside fittings
- Heavy duty bearings in all movable joints for convenient, smooth operation and enhanced durability
- Deep tube fittings in all couplings
- Adjustable set screws allow accurate alignment of supporting tubes
- Oil-resistant neoprene gasket

FINISH

Couplings and access plates have RAL 7035 light-gray polyester powder paint finish. Tubing is anodized aluminum.

INDUSTRY STANDARDS

NEMA/EEMAC Type 12
IEC 60529, IP55
DIN 40050

Standard Cutout for Mounting

Dimensions for Cutout	Set-Up Joint in./mm	Vertical or Horizontal Wall Joint in./mm	Flange or Flange Elbow Coupling/Swivel Tilt Straight or 90° Elbow in./mm	Wall Flange or Base Bracket in./mm	Rotational Base in./mm
ØD	1.58 40	2.76 70	1.58 40	— —	1.58 40
E	3.54 90	3.54 90	2.36 60	3.54 90	3.54 90
F	3.54 90	4.33 110	2.36 60	3.54 90	3.54 90
ØG	0.35 9	0.35 9	0.26 7	0.35 9	0.35 9

See product drawings for alternate shallow enclosure mounting.

Standard Cutout for Mounting

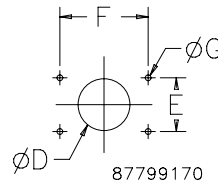

SYSTEM LOAD CAPACITY

The Series 2 pendant arm load graph is the result of load capacity tests. Please contact Hoffman for specific application information.

Load Diagram

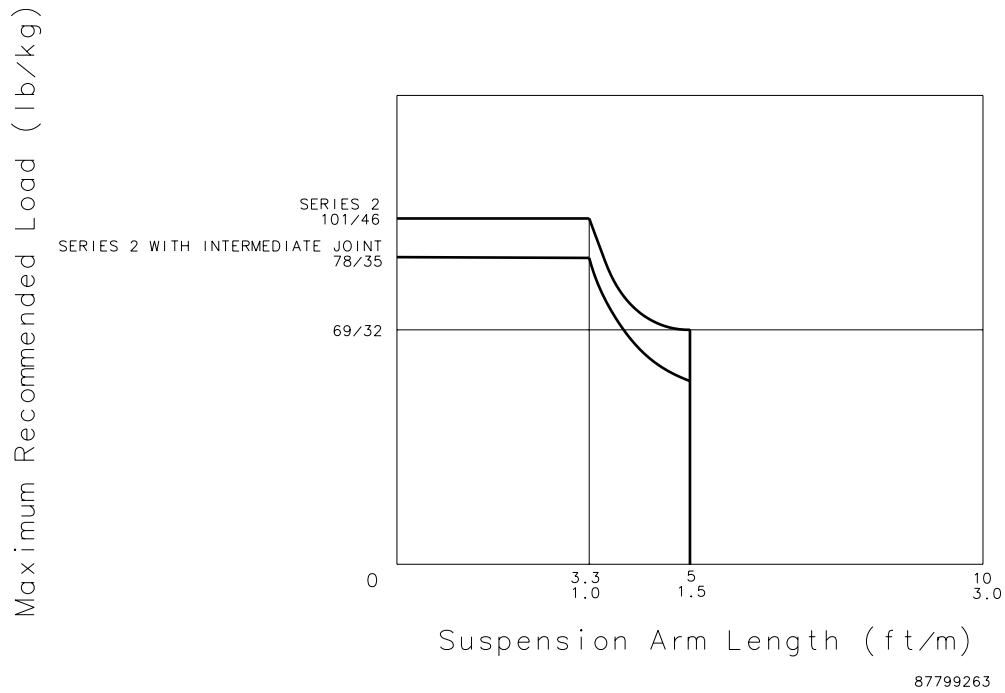
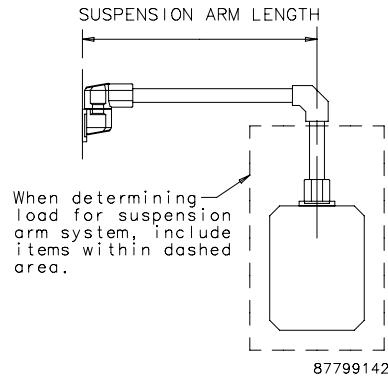

TUBES

Hollow aluminum extrusion available in 500-, 1000- and 1500-mm lengths. Connection components fastened to support arm with set screws. DIN 59411 and 2395.

BULLETIN: CS4

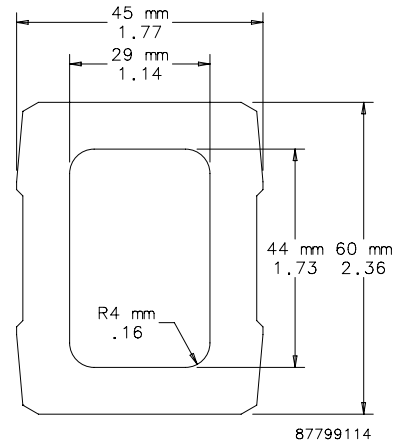

Catalog Number	AxBxC in./mm	Length in./mm	External Dimensions in./mm	Wall Thickness Dimensions in./mm	Inside Cross Section (cm ²)	Inside Cross Section (in. ²)	Weight (lb.)
CCS2T5	19.68 x 1.77 x 2.36	19.68	1.77 x 2.36	0.31	12.65	1.96	4.5
	500 x 45 x 60	500	45 x 60	8			
CCS2T10	39.37 x 1.77 x 2.36	39.37	1.77 x 2.36	0.31	12.65	1.96	9.0
	1000 x 45 x 60	1000	45 x 60	8			
CCS2T20	59.06 x 1.77 x 2.36	59.06	1.77 x 2.36	0.31	12.65	1.96	14.0
	1500 x 45 x 60	1500	45 x 60	8			

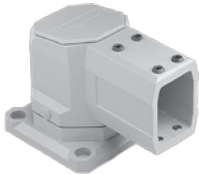
SET-UP JOINT

Joint includes access plate for easy wire installation. Turning range of 300 degrees. Cast aluminum with RAL 7035 light-gray polyester powder paint finish. Setscrews, gasket and removable access plate included. Mounting fasteners are not provided.

BULLETIN: CS4



Catalog Number	Weight (lb.)
CCS2SJLG	4.0

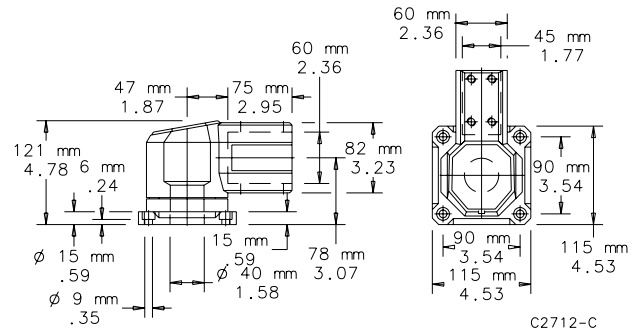

WALL JOINT (VERTICAL)

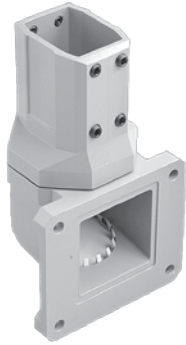

Vertical joint includes access plate for easy wire installation. Turning range of 300 degrees. Cast aluminum with RAL 7035 light-gray polyester powder paint finish. Setscrews, gasket and removable access plate included. Mounting fasteners are not provided.

BULLETIN: CS4



Catalog Number	Weight (lb.)
CCS2WJVLG	5.0

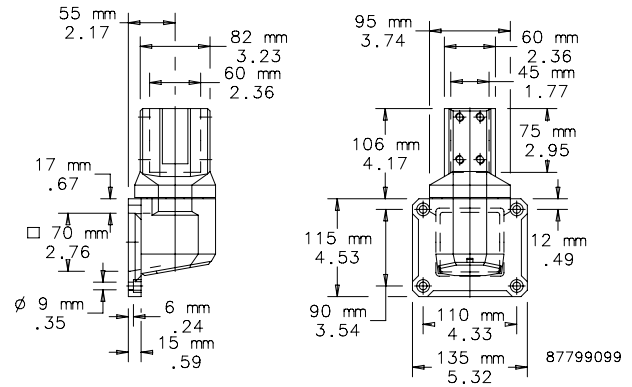

WALL JOINT (HORIZONTAL)



Includes access plates for easy wire installation. Turning range of 300 degrees. Cast aluminum with RAL 7035 light-gray polyester powder paint finish. Setscrews, gasket and removable access plates included. Mounting fasteners not provided.

BULLETIN: CS4



Catalog Number	Weight (lb.)
CCS2WJHLG	5.0

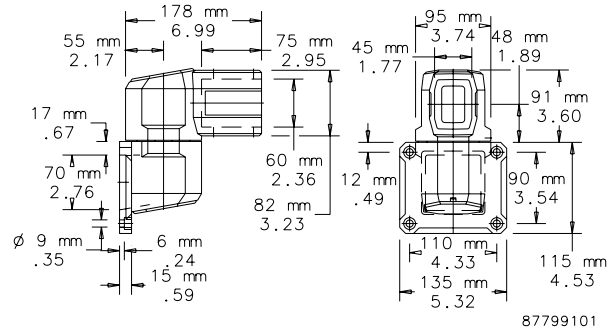

INTERMEDIATE JOINT



Joint is cast aluminum with RAL 7035 light-gray polyester powder paint finish. Turning range is 360 degrees with stop. Includes access plates for easy wire installation, installation hardware and gasket. Use of the intermediate joint reduces pendant arm load capacity by 43 percent.

BULLETIN: CS4



Catalog Number	Weight (lb.)
CCS2IJLG	5.0

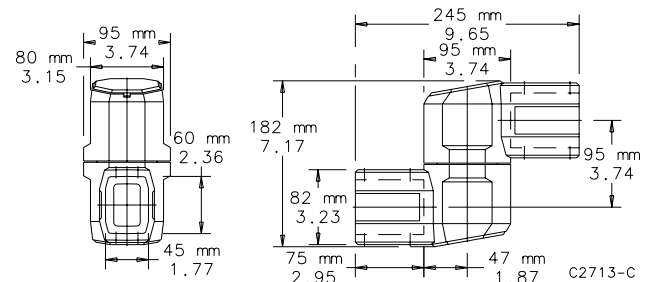

HEAVY DUTY ELBOW



Elbow is made of aluminum with increased wall thickness for additional strength and support. Setscrews for tube adjustment. Cast aluminum with RAL 7035 light-gray polyester powder paint finish. All installation hardware and gasket included.

BULLETIN: CS4



Catalog Number	Weight (lb.)
CCS2EHDLG	3.0

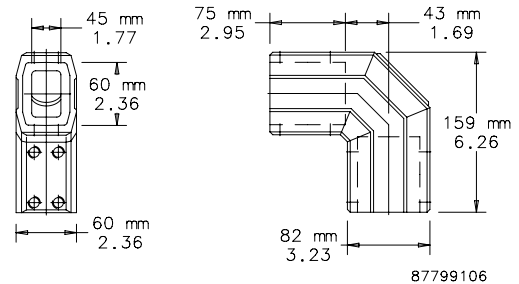

87799106

FLANGE COUPLING



Coupling can rotate 300 degrees. Maintenance-free bearing is steel and polyamide. Cast aluminum with RAL 7035 light-gray polyester powder paint finish. Installation hardware, mounting fasteners and gasket included.

BULLETIN: CS4



Catalog Number	Weight (lb.)
CCS2FCLG	2.5

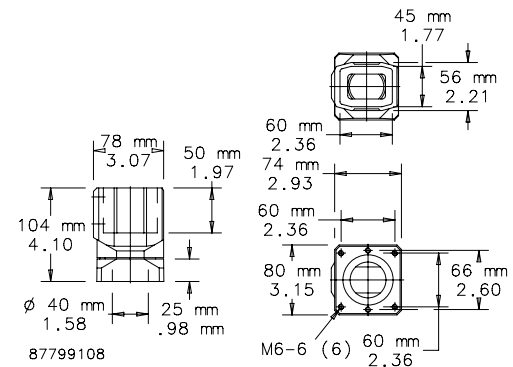

87799108

FLANGE COUPLING, 15-DEGREE



Coupling can rotate 300 degrees. Maintenance-free bearing is steel and polyamide. Enclosure is mounted at a 15-degree incline angle. Cast aluminum with RAL 7035 light-gray polyester powder paint finish. Installation hardware, mounting fasteners and gaskets included.

BULLETIN: CS4



Catalog Number	Product Weight (Lb.)
CCS2FC15LG	2.5

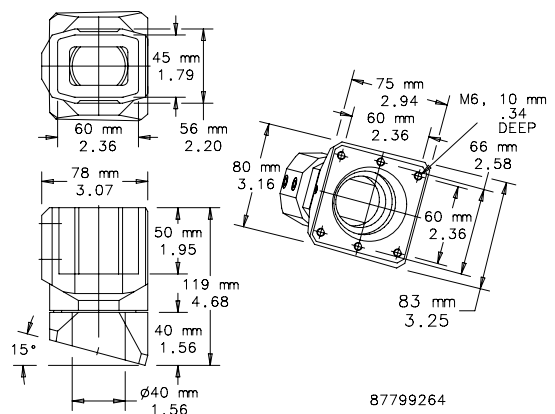

87799264

FLANGE ELBOW COUPLING



Turning range of 300 degrees. Maintenance-free bearing is steel and polyamide. Includes access plate for easy wire installation. Cast aluminum finished in RAL 7035 light-gray polyester powder paint. Installation hardware, mounting fasteners and gasket included.

BULLETIN: CS4



Catalog Number	Weight (lb.)
CCS2FECLG	3.0

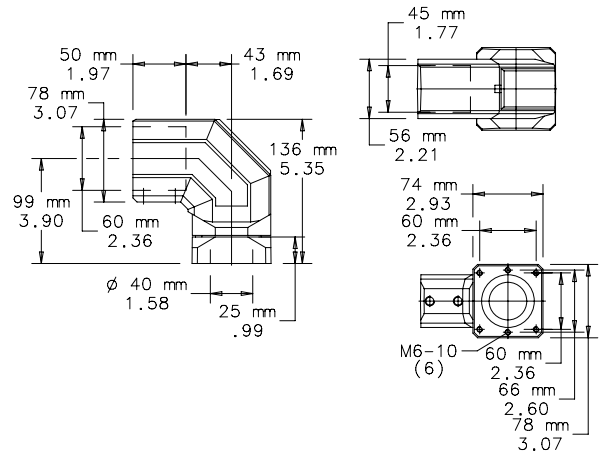

87799110

FLANGE ELBOW COUPLING, 15-DEGREE



Turning range of 300 degrees. Maintenance-free bearing is steel and polyamide. Access plate included for easy wire installation. Enclosure is mounted at a 15-degree incline angle. Cast aluminum finished in RAL 7035 light-gray polyester powder paint. Installation hardware, mounting fasteners and gaskets included.

BULLETIN: CS4



Catalog Number	Product Weight (Lb.)
CCS2FEC15LG	3.1

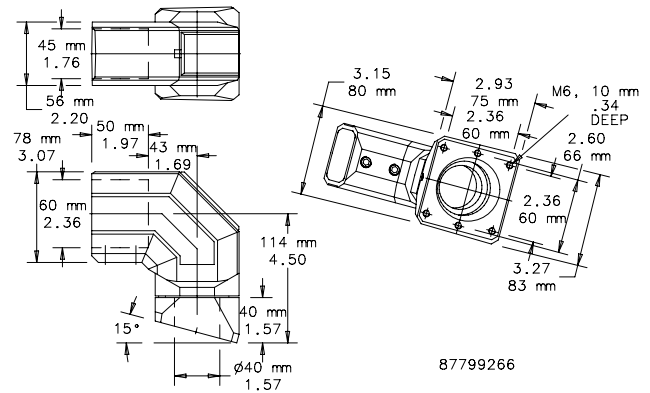

87799266

BASE BRACKET/WALL FLANGE

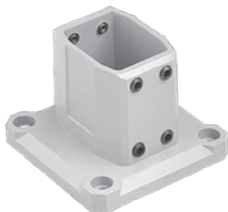

Cast aluminum with RAL 7035 light-gray polyester powder paint finish. Set screws and gasket are not provided. Mounting fasteners are not provided.

BULLETIN: CS4



Catalog Number	Weight (lb.)
CCS2WFBLG	2.5

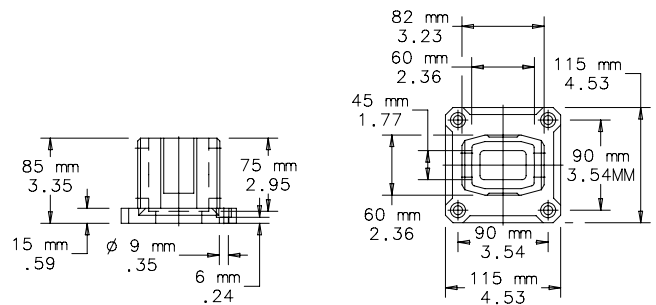

87799112

ROTATIONAL BASE



Turning range of 300 degrees. Cast aluminum finished in RAL 7035 light-gray polyester powder paint. Setscrews and gasket are included. Mounting fasteners are not provided.

BULLETIN: CS4

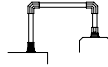

Catalog Number	Weight (lb.)
CCS2RBLG	3.5

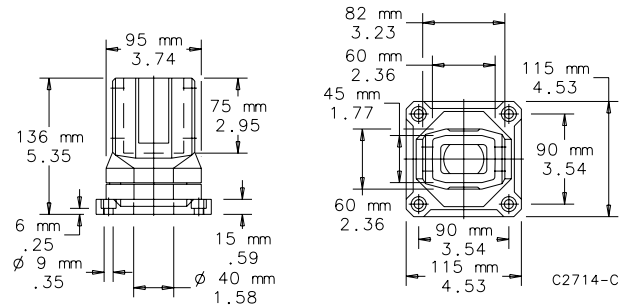

ROTATIONAL BASE BRACKET



Turning range of 300 degrees. Cast aluminum finished in RAL 7035 light-gray polyester powder paint. Setscrews and gaskets are included. Mounting fasteners are not provided.

BULLETIN: CS4



Catalog Number	Product Weight (lb.)
CCS2RBBLG	2.7

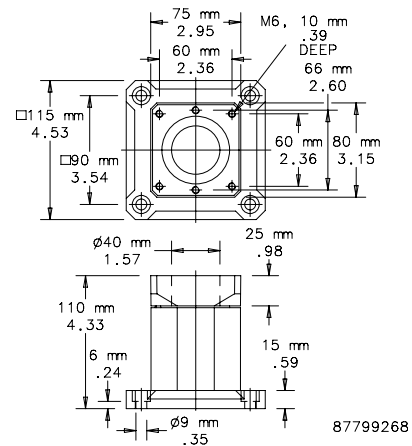

ROTATIONAL BASE BRACKET, 15-DEGREE



Turning range of 300 degrees. Enclosure is mounted at a 15-degree incline angle. Cast aluminum finished in RAL 7035 light-gray polyester powder paint. Setscrews and gaskets are included. Mounting fasteners are not provided.

BULLETIN: CS4



Catalog Number	Product Weight (lbs.)
CCS2RBB15LG	2.7

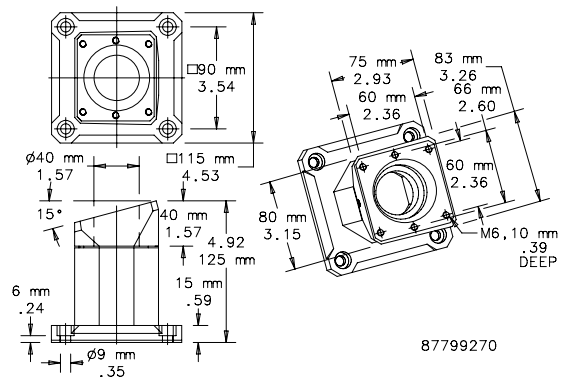

SWIVEL TILT STRAIGHT



Mounts between pendant arm and HMI enclosure to provide both swivel and tilt options for the machine operator. Swivel allows 300-degree maximum rotation. Tilt allows infinite adjustment from horizontal to 30 degrees. Cast aluminum finished in RAL 7035 light-gray polyester powder paint. Installation hardware, mounting fasteners and gasket included.
 Maximum load is 66 lb. (30 kg).

BULLETIN: CS4



Catalog Number	Weight (lb.)
CCS2STLG	7.0

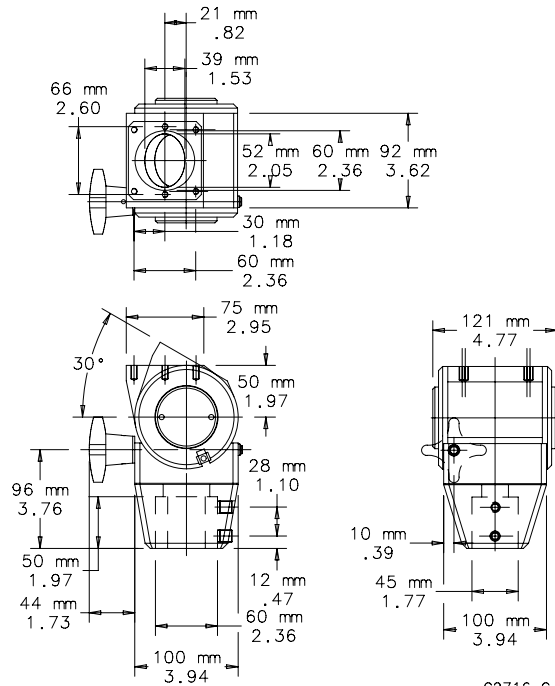

SWIVEL TILT 90-DEGREE ELBOW



Mounts between pendant arm and HMI enclosure to provide both swivel and tilt options for the machine operator. A 90-degree elbow is incorporated into this design. Swivel allows 300-degree maximum rotation. Tilt allows infinite adjustment from horizontal to 30 degrees. Cast aluminum finished in RAL 7035 light-gray polyester powder paint. Installation hardware, mounting fasteners and gasket are included.
 Maximum load is 66 lb. (30 kg).

BULLETIN: CS4



Catalog Number	Weight (lb.)
CCS2ESTLG	7.5

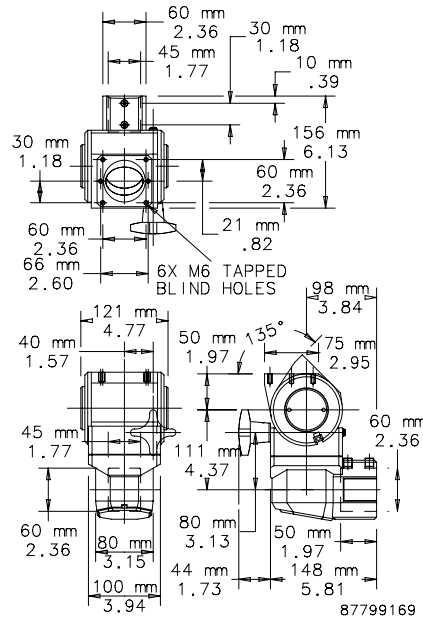

PEDESTAL BASE



Base is cast aluminum one-piece construction finished with RAL 7035 light-gray textured polyester powder paint. Includes all hardware for attaching tubes.

BULLETIN: CC3

Catalog Number
CCS2PB

MONITOR PLATFORM

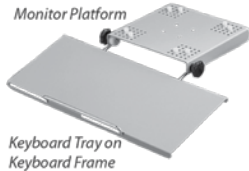

Platform attaches to pendant arm to provide a surface for a monitor. Adjustable stops hold monitor securely in place. Aluminum construction finished with RAL 7042 gray polyester powder paint. Order Monitor Platform, Keyboard Tray and Keyboard Frame separately.

BULLETIN: CS4

Catalog Number	Description
CCS1MP	Monitor Platform (Does not include Keyboard Frame or Keyboard Tray)

KEYBOARD FRAME

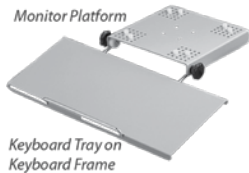

Mounts to monitor platform. Frame locks at desired position by tightening knobs. Chrome plated finish. Order Monitor Platform, Keyboard Tray and Keyboard Frame separately.

BULLETIN: CS4

Catalog Number	Description
CCS1KBF	Keyboard Frame only

KEYBOARD TRAY

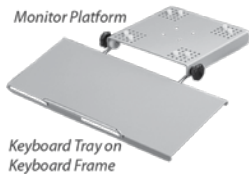

Tray attaches to keyboard frame. Provides a surface for a PC mouse as well as a platform for a keyboard. Aluminum construction finished with RAL 7042 gray polyester powder paint. Order Monitor Platform, Keyboard Tray and Keyboard Frame separately.

BULLETIN: CS4

Catalog Number	Description
CCS1KBT	Keyboard Tray only

COMPACT™ PENDANT ARM SERIES 2 CONFIGURATIONS

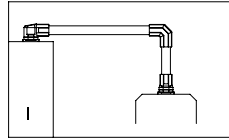

87799173

1

Description	Qty.	Catalog Number
Set up joint	1	CCS2JLG
Heavy duty elbow	1	CCS2EHDLG
Flange coupling or Swivel tilt	1	CCS2FCLG
	1	CCS2STLG

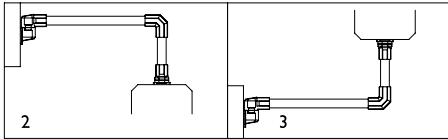

87799174

2 AND 3

Description	Qty.	Catalog Number
Wall joint (horizontal)	1	CCS2WJHLG
Heavy duty elbow	1	CCS2EHDLG
Flange coupling or Swivel tilt or	1	CCS2FCLG
	1	CCS2STLG
Flange coupling 15°	1	CCS2FC15LG

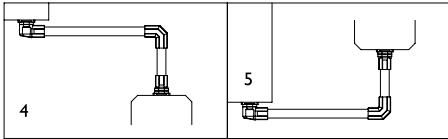

87799175

4 AND 5

Description	Qty.	Catalog Number
Set up joint	1	CCS2SJLG
Heavy duty elbow	1	CCS2EHDLG
Flange coupling or Swivel tilt	1	CCS2FCLG
	1	CCS2STLG

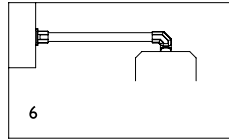

87799176

6

Description	Qty.	Catalog Number
Wall flange/base bracket	1	CCS2WFBLG
Flange elbow coupling or 90° Swivel tilt or	1	CCS2FECLG
	1	CCS2ESTLG
Flange elbow coupling 15°	1	CCS2FEC15LG

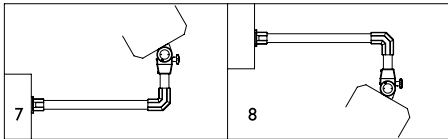

87799177

7 AND 8

Description	Qty.	Catalog Number
Wall flange/base bracket	1	CCS2WFBLG
Heavy duty elbow	1	CCS2EHDLG
Flange coupling or Swivel tilt	1	CCS2FCLG
	1	CCS2STLG

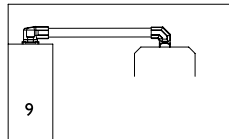

87799178

9

Description	Qty.	Catalog Number
Set-up joint	1	CCS2SJLG
Flange elbow coupling or 90° Swivel tilt	1	CCS2FECLG
	1	CCS2ESTLG

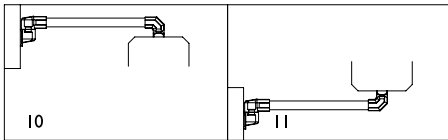

87799179

10 AND 11

Description	Qty.	Catalog Number
Wall joint (horizontal)	1	CCS2WJHLG
Flange elbow coupling or 90° Swivel tilt	1	CCS2FECLG
	1	CCS2ESTLG

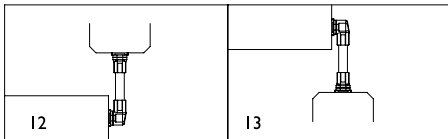

87799180

12 AND 13

Description	Qty.	Catalog Number
Wall joint (vertical)	1	CCS2WJVLG
Flange coupling or Swivel tilt	1	CCS2FCLG
	1	CCS2STLG

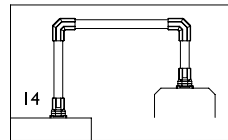

87799181

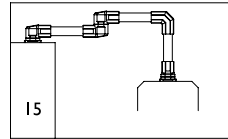

87799182

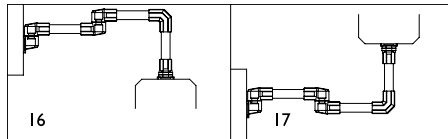

87799183

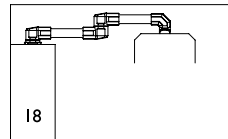

87799184

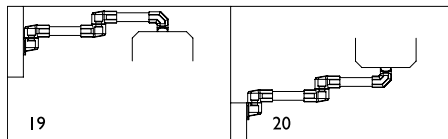

87799185

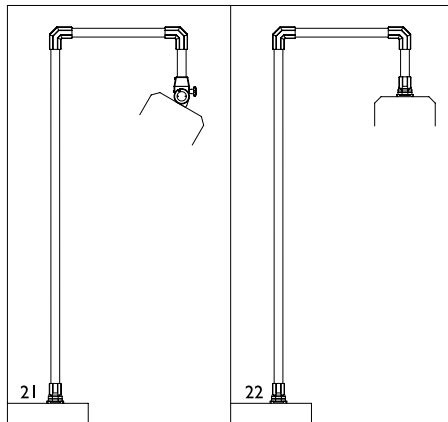

C2802-C

14

Description	Qty.	Catalog Number
Rotational base	1	CCS2RBLG
Heavy duty elbow	2	CCS2EHDLG
Flange coupling or Swivel tilt	1	CCS2FCLG
	1	CCS2STLG

15

Description	Qty.	Catalog Number
Set up joint	1	CCS2SJLG
Intermediate joint	1	CCS2IJLG
Heavy duty elbow	1	CCS2EHDLG
Flange coupling or Swivel tilt	1	CCS2FCLG
	1	CCS2STLG

16 AND 17

Description	Qty.	Catalog Number
Wall Joint (horizontal)	1	CCS2WJHLG
Intermediate joint	1	CCS2IJLG
Heavy duty elbow	1	CCS2EHDLG
Flange coupling or Swivel tilt	1	CCS2FCLG
	1	CCS2STLG

18

Description	Qty.	Catalog Number
Set up joint	1	CCS2SJLG
Intermediate joint	1	CCS2IJLG
Flange elbow coupling or 90° Swivel tilt	1	CCS2FECLG
	1	CCS2ESTLG

19 AND 20

Description	Qty.	Catalog Number
Wall joint (horizontal)	1	CCS2WJHLG
Intermediate joint	1	CCS2IJLG
Flange elbow coupling or 90° Swivel tilt	1	CCS2FECLG
	1	CCS2ESTLG

21 AND 22

Description	Qty.	Catalog Number
Wall flange/base bracket	1	CCS2WFBLG
Heavy duty elbow	1	CCS2EHDLG
Flange coupling or Swivel tilt	1	CCS2FCLG
	1	CCS2STLG

Note to the Specifier:

1. Select pendant system sizing using the COMPACT Series 2 load capacity chart.
2. Tube catalog numbers are not included in configuration tables.

Notes

X-ON Electronics

Largest Supplier of Electrical and Electronic Components

Click to view similar products for [Hoffman](#) manufacturer:

Other Similar products are found below :

[A-1412CHQR](#) [A-6P4G](#) [A-202408LP](#) [CSD20168SS](#) [CSD20206](#) [CSD20208SS](#) [CSD24168](#) [CSD36248](#) [CSD36308](#) [PCU7](#) [PDS76R](#)
[PRA197TP](#) [PT126](#) [A10086CH](#) [A1008CHNFSS](#) [A10106CH](#) [A10106CHFL](#) [A10106PHCW](#) [A1043DSC](#) [A1066JFGQRR](#) [A12106CHQRFG](#)
[A1212SC](#) [A1412CHNFSS](#) [A161208LP](#) [A161410CH](#) [A16148CHQRFG](#) [A16H12ALP](#) [A18P16AL](#) [A24H2408SSLP](#) [A24H24BLP](#)
[Q13138PCE](#) [A36P24](#) [Q3PBPCDM](#) [A404CH](#) [A606CHNF](#) [A606NF](#) [A806SC](#) [A845JFGR](#) [A864CHQRFGW](#) [A90P36F1](#) [HJ1412HWPL2LG](#)
[HJ1816HWPL2LG](#) [RHJ1210HWPL2LG](#) [AS125SS](#) [ASE10X10X4](#) [ASE12X12X4](#) [E1PBG](#) [E2PBG](#) [E3PB](#) [LED24V15](#)