

- ① FANS MOUNTING HOLE  $\phi 4.5\text{mm}$   
CHASSIS THICKNESS 3.5~4mm
- ② SUPPORT MOUNTING HOLE  $\phi 4.5\sim\phi 4.8\text{mm}$   
CHASSIS THICKNESS 0.8~2mm

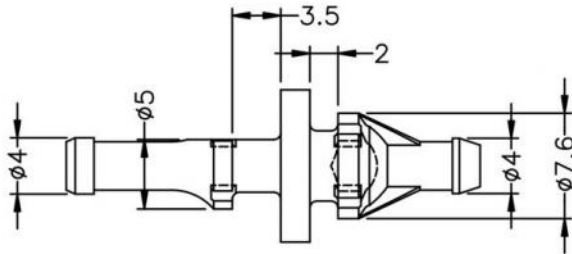

G: HARDNESS IS SHORE A45

H: HARDNESS IS SHORE A55

Akust Technology Co., Ltd  
亞冠國際有限公司

PART NUMBER		P02-0001-0006	SPEC. DWG.	
TITLE				
FAN SNAP RIVET				
MATERIAL			COLOR	
TPE			BLACK	
SIZE	SCALE	UNIT	CHECK	
A4	2:1	mm	Z.C	

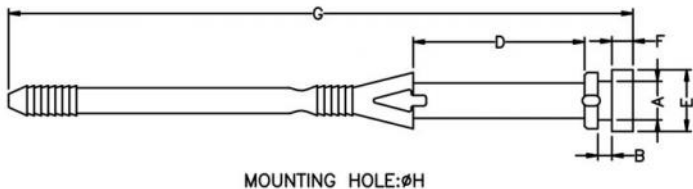

A	B	D	E	F	G	H
4.4	1.6	19.5	7.0	2.4	71.0	4.4

G: HARDNESS IS SHORE A45  
 H: HARDNESS IS SHORE A55

<b>Akust Technology Co., Ltd</b> 亞冠國際有限公司	PART NUMBER		P02-0001-0007	SPEC. DWG.		
	TITLE					FAN SNAP RIVET
	MATERIAL			TPE	COLOR	BLACK
	SIZE	A4	SCALE	2:1	UNIT	mm
				CHECK	Z.C	

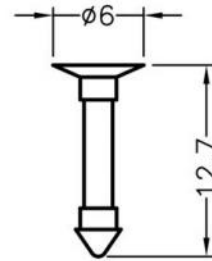
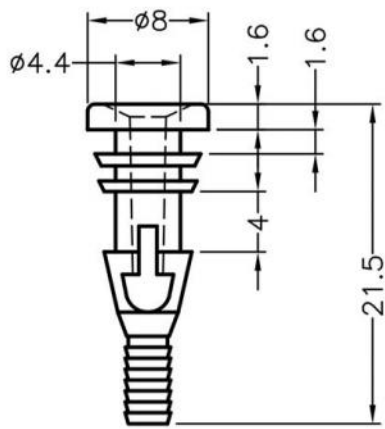

CHASSIS HOLE  $\phi 4.8 \sim \phi 5.0$

MATERIAL		COLOR
1	TPE	BLACK
2	NYLON 66(UL) 94V-2	BLACK

M2 is PIN.

Akust Technology Co., Ltd  
亞冠國際有限公司

PART NUMBER		P02-0001-0008	SPEC. DWG.	
TITLE				
FAN SNAP RIVET				
MATERIAL			COLOR	
SEE ABOVE			SEE ABOVE	
SIZE	SCALE	UNIT	CHECK	
A4	2:1	mm	Z.C	

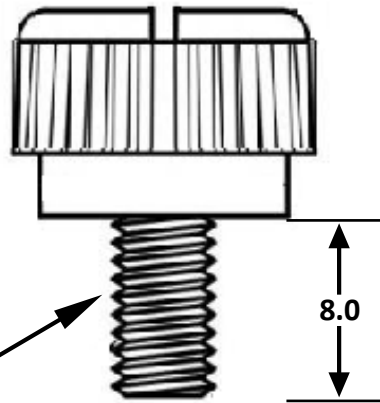

6-32 UNC

材質 MATERIAL: STEEL	
品號 ITEM NO.: AV05-0000-AKS (4)	
製圖 DRAWN: JON	日期 DATE: 20
確認 APPROVED: DICK	單位 UNIT: mr

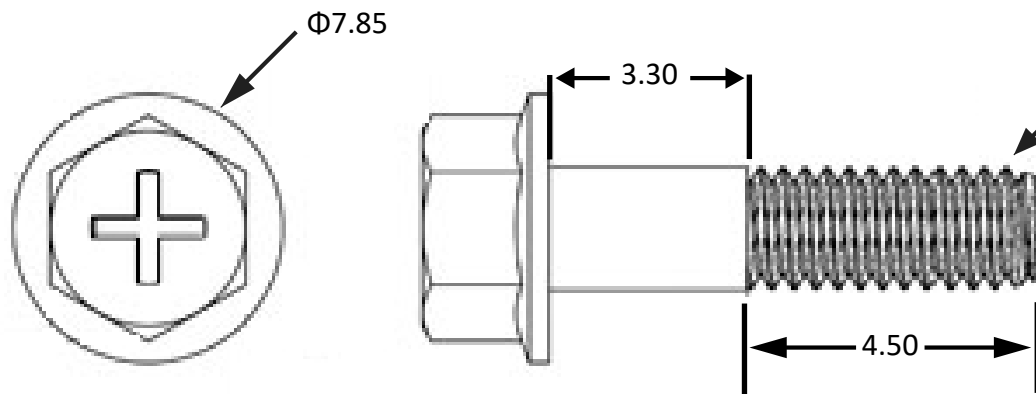

材質 MATERIAL: STELL	
品號 ITEM NO.: AV05-0000-AKS (5)	
製圖 DRAWN: JON	日期 DATE: 20
確認 APPROVED: DICK	單位 UNIT: mm

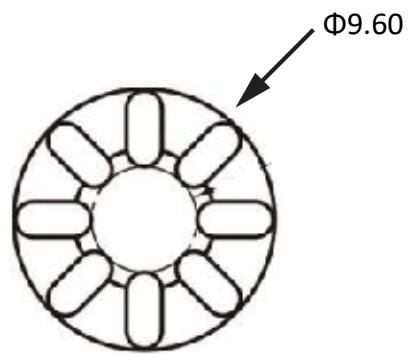

材質 MATERIAL: RUBBER

品號 ITEM NO.: AV05-0000-AKS (6)

製圖 DRAWN: ALAN

日期 DATE: 20

確認 APPROVED: DICK

單位 UNIT: mm

## **X-ON Electronics**

Largest Supplier of Electrical and Electronic Components

*Click to view similar products for [AKUST TECHNOLOGY](#) manufacturer:*

Other Similar products are found below :

[FG04-0114-AKS](#) [BAB/CG](#) [SK00-0038-AKS](#) [FG00-0040-AKS](#) [SK00-0044-AKS](#)