



# DTMF-02 4 OUTPUTS DTMF RECEIVER.



The DTMF-2 allows to decode the DTMF tones from 0 to 9, \* and #, connecting or disconnecting according to the control signals sent by the emitter the corresponding outputs.  
It includes password or access code function and outputs individual configuration in standard, flip-flop or timer modes.  
It is totally compatible with Cebek DTMF emitters and it can be installed on DIN Rail ref C-7586.

### TECHNICAL CHARACTERISTICS.

Voltage	12 / 24 V. D.C.
Min/Max Consumption	20 / 240 mA.
DTMF input signal, min. / max.	-29 / 1 dBm.
Memory capacity/password	1-10 tones.
Memory's typical life	100.000 cycles / 100 years of retention.
Protection Against Polarity Inversion	Volatile Input.
Max load per relay	250 V. / 5 A.
Outputs operating	Standard/Flip-flop/Timed (1 to 254 sec).
Main board dimensions	107 x 87,5 x 30 mm.

### POWER SUPPLY and INSTALLATION.

**POWER SUPPLY.** The DTMF-2 circuit is composed by 2 independent power supply inputs with a common negative, one at 12 V DC and one at 24 V DC. For a correct module's operating mode, you have to select a voltage among these two possibilities, and do never use both at the same time. Then, if you select 12 or 24 V, you have to use a power supply correctly filtered. We recommend you to use a short circuit power supply with a low ripple level like our FE-113, which has been developed to perfectly answer to the circuit needs. Do never use basic power supply neither rectifiers to avoid to damage devices.  
**Note:** Install a fuse and a switch on the mains power input, both are necessary for the module's protection as well as for your own safety, as it is required by the "CE" regulations. See the general wiring map.

**INSTALLATION.** The module's installation has to be done in a waterproof place, avoiding any contact between circuit and other metallic objects. The module can't be installed in place with a high humidity or temperature, or with the possibility to be in contact with liquids.  
All connections, as well as the complete read of this present instruction manual have to be done before to supply the module.

**WIRING.** In the wiring you have to respect the polarity of different inputs, and the length of the used cable as to be as short as possible (mainly for the DTMF connection). If the required distance is superior than 2m, or for places including many industrial atmospheres, you have to use shielded cable and to connect the braid to the corresponding screw indicated with the ground symbol (negative). For the power supply input (power), you have to use parallel cable with a maximum length of 2 m.  
DTMF Emitter-Receiver connection. The DTMF input allows signals between 29 dBm (min) and 1 dBm (max), internally preamplifying before to process it.  
The connection between Cebek DTMF emitter and receivers is done connecting the IN input of the receiver with the OUT output of the corresponding emitter's DTMF Clema. The ground terminal of both clemas has to be also connected between both modules if they are supplied with different power supplies. If modules are supplied with the same power supply, it is not necessary to connect both grounds.

Fig. 1. Connection between DTMF Emitter and receiver

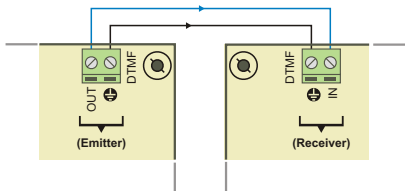

**OUTPUT. CONNECTION OF THE LOAD.** Module outputs re controlled by a relay, insulated device allowing any load until 5.A, as maximum consumption **The relay is not a component supplying voltage**, but its function is to allow or deny the electrical flow supplied through its contacts, like a standard switch. For this reason, you have to supply the load through this device. The relay has 3 output terminals the normally open at quiescent (NO), the normally closed at quiescent (NC) and the common. The operating mode of this mechanism is the same as a switch with two (2) terminals NO and common as it is indicated in the Fig. N°1 .  
For the inverse function you have to place the load between the NC and Common.

Fig. 2. Ejemplos de Conexión de la Carga.

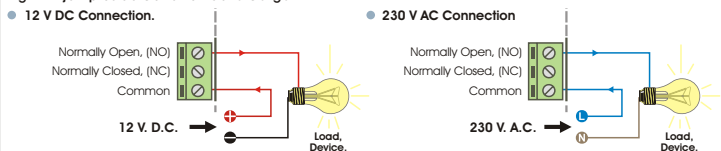

**INFORMATION ABOUT THE OUTPUT.** Specially with inductive loads, a relay can generate a fluctuation or an incorrect output operating mode. In such case, you have to install an anti-spark circuit between both contacts of the relay used in this connection, as it is indicated on the drawing, to absorb the current peak provoking the mentioned problem.

If the load connected to the circuit is supplied at 230V, you have to use a **X2 type 100nF/400 V** capacitor type and a 47W, 1/2 W resistor (See fig. 2). If the load is supplied at 12 or 24 V, remove the resistor and install only a **X2 type** capacitor between relay both contacts.  
You must try values between 10nF and 47nF till the fluctuation disappears.

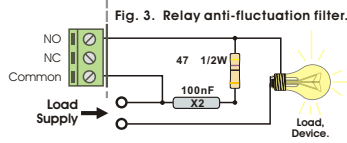

Fig. 3. Relay anti-fluctuation filter.

### OPERATING MODE

**INDICADORES.** Existen cuatro leds indicadores en el circuito, cada uno de los cuales puede asumir la visualización de varias funciones.

- Led Pwr.** (Rojo). Se mantiene iluminado mientras el módulo esté alimentado.
- Led Tone.** (Verde). Se iluminará durante la recepción de un tono dtmf.
- Led Prg.** (Rojo). Permanecerá iluminado mientras el circuito se encuentre en modo programación, (password o relés), desactivándose en el modo de funcionamiento estándar.
- Led Pass.** (Amarillo). Si se encuentra iluminado indica que el receptor opera con password. En caso contrario permanecerá apagado.
- Leds Ld1 a Ld8.** (Verdes). Se iluminarán mientras la correspondiente salida se encuentre activada, desconectándose a la par que ésta.

**OPERATING MODE.** Each time it will receive the DTMF code corresponding to a pressed key in the emitter, the circuit will process and activate the corresponding output. If the module has activated the access through a password, before each output number, the password must be inserted.  
The tones corresponding to keys 1 to 8 will independently activate the corresponding output, and disconnected this output once the programmed timer is done; this time could be selected between 1 and 250 sec (as maximum); if they were configured in flip-flop mode, they will remain activated till the same output number is sent, at this moment they will be disconnected; or if they were configured in standard mode, they will remain activated while the corresponding key is pressed in the emitter.  
When any output is activated, in standard, flip-flop or timered mode, a new control tone of the same will deactivate it, used also as individual reset.

### OPERATING MODE

The tone corresponding to "0" key will disconnect all activated outputs at the same time, independently of their configuration, used as common Reset.  
The "\*" and "#" tones don't have influence on output connection, but they are used for password programming codes and outputs programming.

**Output Programming.** Standard/Flip-Flop/Timered mode. Each output can be configured in. Standard/Flip-Flop/Timered mode.  
If you have a DTMF Cebek emitter and you don't have activated the receiver control through a password or the emitter's automatic password function, you can accede to the outputs programming mode through the fast access command (# + 5).  
At the opposite side, you must press the own receiver outputs programming code, \*00 (tone \*, followed of the "0" tone and a new tone zero). If the module is protected through a password, this one must to be inserted previously to the programming code.  
If the operation is correctly done, the LED Prg will be permanently lighted on. Once the LED Prg is lighted on, you must to press the output number to activate (1 to 8), and then a number composed by three digits. This number from the 001 to the 254 will assign the quantity of seconds that the output will remain timered after each activation.  
If the introduced number is 000, the output will operate in Flip-Flop mode. If the number is superior to 255, the output will operate in standard mode. If the number is superior to 255, the receiver will be automatically programmed in standard mode.  
Once the three digits are inserted, the output will be programmed with it and the circuit will leave the programming mode, and you must repeat this process for others outputs.

Fig. 4. To program the receiver through own codes.

	Step 1	Step 2	Step 3
To program the Password	* , 9 , 9	Password	*
To eliminate the Password (previously you have to insert the anterior password)	* , 9 , 9	#	-----
To program Relays	* , 0 , 0	n° Relay (1 to 8)	Timer. Relay (000 to 250)

**To program the Password.** The Cebek receivers can operate with password. Nevertheless, for security reasons, once programmed, the receiver will not allow any control or programming action on it, if it is not previously introduced the password. This operating characteristic allows that a security code badly introduced, or not remembered, disables any operation on the receiver, without possibility to deactivate it; it will only be possible to return the module to the factory to restore the whole system.  
For this reason we strongly recommend you to pay a maximum attention and care during the recording operation, following the instructions indicated in this manual. Cebek can't be considered responsible for the blockade of your receivers due to such circumstances, being excluded from the product warranty.  
If you have a Cebek DTMF emitter and the receiver's control by password is not activated, nor the emitter's automatic password, you can reach the outputs programming mode through the fast access command (# + 4).

In the opposite case, the own receiver's password programming code must be pressed, \*99, (tone \*, followed of the "9" tone and a new 9 tone). If the module is protected by a previous password, this one must to be introduced previously to the programming code.  
If the operation is correctly done, the access to the password memory programming will be indicated by the illumination of the LED Prg.  
Then, you could insert one by one, pressing the corresponding emitter's key, the different tones to store. Each tone or pulse must be clearly done, trying to not press two keys at the same time. For this reason, we strongly recommend you to previously choose a password to avoid doubting during the recording time. Finally, a last pulsation on the asterisk key, will automatically store to the different tones introduced in the receiver's memory, and automatically activating the control by password of the same. (LED Pass lighted on). The password configuration is delimited between 1 tone (minimum) and 10 tones (maximum), being subscribed to the corresponding tones from 0 to 9.  
If the memory maximum capacity is surpassed, (10 tones), if the asterisk key is not pressed after the code, or if there are more than 5 sec between pulsation and pulsation, the circuit will cancel the recording, leaving the programming mode without any change on the memory.

To eliminate the password. The access by password, once activated, only can be deactivated eliminating it from the circuit memory. The process will be the same than the password programming. Firstly you have to insert the valid password, then the password programming code, (\*99), and finally press the pad key, (#).  
If the operation is correctly done, the LED Prg will confirm through a short intermittence before the module leaves the programming mode, deactivating the access by password and erasing the memory.

### GENERAL WIRING MAP

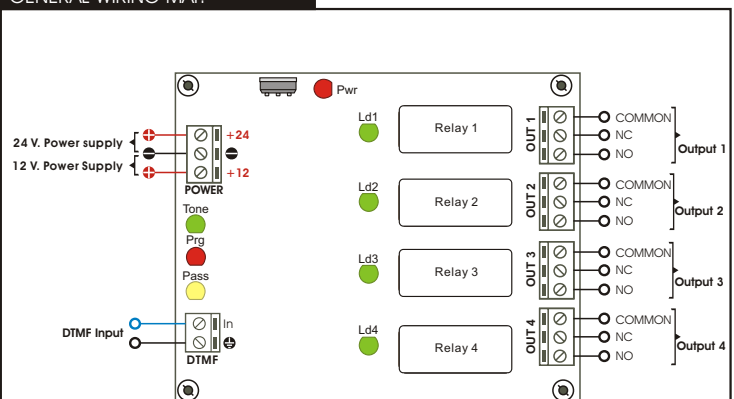

### TECHNICAL SUPPORT AND INFORMATION.

For any questions or more information:  
**By Fax.** (24h.) + 34.93.432.29.95 **By Mail:** C/ Quetzal, 17-21, Entlo. 2º (08014) BARCELONA - SPAIN.  
**By E-Mail:** [sat@cebek.com](mailto:sat@cebek.com)  
**Keep you invoice.** For any repairing could you send this with module.  
Else, the module will lost the warranty.



All the module's CEBEK have **3 years of total warranty** in thechnical repairing, and spares from the date of buy.  
CEBEK is trade make of FADISEL S.L. more than 300 module's are available in stock for any purpose **request our CATALOGUE**, or visit our Web site [www.cebek.com](http://www.cebek.com)



## **X-ON Electronics**

Largest Supplier of Electrical and Electronic Components

*Click to view similar products for [cebek](#) manufacturer:*

Other Similar products are found below :

[I-33](#) [I-1](#) [I-10](#)