

SH7146 Group

User's Manual: Hardware

Renesas 32-Bit RISC Microcomputer
SuperH™ RISC engine Family

SH7146

R5F7146

R5M7146

SH7149

R5F7149

R5M7149

Notice

1. All information included in this document is current as of the date this document is issued. Such information, however, is subject to change without any prior notice. Before purchasing or using any Renesas Electronics products listed herein, please confirm the latest product information with a Renesas Electronics sales office. Also, please pay regular and careful attention to additional and different information to be disclosed by Renesas Electronics such as that disclosed through our website.
2. Renesas Electronics does not assume any liability for infringement of patents, copyrights, or other intellectual property rights of third parties by or arising from the use of Renesas Electronics products or technical information described in this document. No license, express, implied or otherwise, is granted hereby under any patents, copyrights or other intellectual property rights of Renesas Electronics or others.
3. You should not alter, modify, copy, or otherwise misappropriate any Renesas Electronics product, whether in whole or in part.
4. Descriptions of circuits, software and other related information in this document are provided only to illustrate the operation of semiconductor products and application examples. You are fully responsible for the incorporation of these circuits, software, and information in the design of your equipment. Renesas Electronics assumes no responsibility for any losses incurred by you or third parties arising from the use of these circuits, software, or information.
5. When exporting the products or technology described in this document, you should comply with the applicable export control laws and regulations and follow the procedures required by such laws and regulations. You should not use Renesas Electronics products or the technology described in this document for any purpose relating to military applications or use by the military, including but not limited to the development of weapons of mass destruction. Renesas Electronics products and technology may not be used for or incorporated into any products or systems whose manufacture, use, or sale is prohibited under any applicable domestic or foreign laws or regulations.
6. Renesas Electronics has used reasonable care in preparing the information included in this document, but Renesas Electronics does not warrant that such information is error free. Renesas Electronics assumes no liability whatsoever for any damages incurred by you resulting from errors in or omissions from the information included herein.
7. Renesas Electronics products are classified according to the following three quality grades: "Standard", "High Quality", and "Specific". The recommended applications for each Renesas Electronics product depends on the product's quality grade, as indicated below. You must check the quality grade of each Renesas Electronics product before using it in a particular application. You may not use any Renesas Electronics product for any application categorized as "Specific" without the prior written consent of Renesas Electronics. Further, you may not use any Renesas Electronics product for any application for which it is not intended without the prior written consent of Renesas Electronics. Renesas Electronics shall not be in any way liable for any damages or losses incurred by you or third parties arising from the use of any Renesas Electronics product for an application categorized as "Specific" or for which the product is not intended where you have failed to obtain the prior written consent of Renesas Electronics. The quality grade of each Renesas Electronics product is "Standard" unless otherwise expressly specified in a Renesas Electronics data sheets or data books, etc.

"Standard": Computers; office equipment; communications equipment; test and measurement equipment; audio and visual equipment; home electronic appliances; machine tools; personal electronic equipment; and industrial robots.

"High Quality": Transportation equipment (automobiles, trains, ships, etc.); traffic control systems; anti-disaster systems; anti-crime systems; safety equipment; and medical equipment not specifically designed for life support.

"Specific": Aircraft; aerospace equipment; submersible repeaters; nuclear reactor control systems; medical equipment or systems for life support (e.g. artificial life support devices or systems), surgical implantations, or healthcare intervention (e.g. excision, etc.), and any other applications or purposes that pose a direct threat to human life.
8. You should use the Renesas Electronics products described in this document within the range specified by Renesas Electronics, especially with respect to the maximum rating, operating supply voltage range, movement power voltage range, heat radiation characteristics, installation and other product characteristics. Renesas Electronics shall have no liability for malfunctions or damages arising out of the use of Renesas Electronics products beyond such specified ranges.
9. Although Renesas Electronics endeavors to improve the quality and reliability of its products, semiconductor products have specific characteristics such as the occurrence of failure at a certain rate and malfunctions under certain use conditions. Further, Renesas Electronics products are not subject to radiation resistance design. Please be sure to implement safety measures to guard them against the possibility of physical injury, and injury or damage caused by fire in the event of the failure of a Renesas Electronics product, such as safety design for hardware and software including but not limited to redundancy, fire control and malfunction prevention, appropriate treatment for aging degradation or any other appropriate measures. Because the evaluation of microcomputer software alone is very difficult, please evaluate the safety of the final products or system manufactured by you.
10. Please contact a Renesas Electronics sales office for details as to environmental matters such as the environmental compatibility of each Renesas Electronics product. Please use Renesas Electronics products in compliance with all applicable laws and regulations that regulate the inclusion or use of controlled substances, including without limitation, the EU RoHS Directive. Renesas Electronics assumes no liability for damages or losses occurring as a result of your noncompliance with applicable laws and regulations.
11. This document may not be reproduced or duplicated, in any form, in whole or in part, without prior written consent of Renesas Electronics.
12. Please contact a Renesas Electronics sales office if you have any questions regarding the information contained in this document or Renesas Electronics products, or if you have any other inquiries.

(Note 1) "Renesas Electronics" as used in this document means Renesas Electronics Corporation and also includes its majority-owned subsidiaries.

(Note 2) "Renesas Electronics product(s)" means any product developed or manufactured by or for Renesas Electronics.

General Precautions in the Handling of MPU/MCU Products

The following usage notes are applicable to all MPU/MCU products from Renesas. For detailed usage notes on the products covered by this manual, refer to the relevant sections of the manual. If the descriptions under General Precautions in the Handling of MPU/MCU Products and in the body of the manual differ from each other, the description in the body of the manual takes precedence.

1. Handling of Unused Pins

Handle unused pins in accord with the directions given under Handling of Unused Pins in the manual.

- The input pins of CMOS products are generally in the high-impedance state. In operation with an unused pin in the open-circuit state, extra electromagnetic noise is induced in the vicinity of LSI, an associated shoot-through current flows internally, and malfunctions may occur due to the false recognition of the pin state as an input signal. Unused pins should be handled as described under Handling of Unused Pins in the manual.

2. Processing at Power-on

The state of the product is undefined at the moment when power is supplied.

- The states of internal circuits in the LSI are indeterminate and the states of register settings and pins are undefined at the moment when power is supplied.
In a finished product where the reset signal is applied to the external reset pin, the states of pins are not guaranteed from the moment when power is supplied until the reset process is completed.
In a similar way, the states of pins in a product that is reset by an on-chip power-on reset function are not guaranteed from the moment when power is supplied until the power reaches the level at which resetting has been specified.

3. Prohibition of Access to Reserved Addresses

Access to reserved addresses is prohibited.

- The reserved addresses are provided for the possible future expansion of functions. Do not access these addresses; the correct operation of LSI is not guaranteed if they are accessed.

4. Clock Signals

After applying a reset, only release the reset line after the operating clock signal has become stable. When switching the clock signal during program execution, wait until the target clock signal has stabilized.

- When the clock signal is generated with an external resonator (or from an external oscillator) during a reset, ensure that the reset line is only released after full stabilization of the clock signal. Moreover, when switching to a clock signal produced with an external resonator (or by an external oscillator) while program execution is in progress, wait until the target clock signal is stable.

5. Differences between Products

Before changing from one product to another, i.e. to one with a different type number, confirm that the change will not lead to problems.

- The characteristics of MPU/MCU in the same group but having different type numbers may differ because of the differences in internal memory capacity and layout pattern. When changing to products of different type numbers, implement a system-evaluation test for each of the products.

Configuration of This Manual

This manual comprises the following items:

1. General Precautions in the Handling of MPU/MCU Products
2. Configuration of This Manual
3. Preface
4. Contents
5. Overview
6. Description of Functional Modules
 - CPU and System-Control Modules
 - On-Chip Peripheral Modules

The configuration of the functional description of each module differs according to the module. However, the generic style includes the following items:

 - i) Feature
 - ii) Input/Output Pin
 - iii) Register Description
 - iv) Operation
 - v) Usage Note

When designing an application system that includes this LSI, take notes into account. Each section includes notes in relation to the descriptions given, and usage notes are given, as required, as the final part of each section.

7. List of Registers
8. Electrical Characteristics
9. Appendix
 - Product Type, Package Dimensions, etc.
10. Main Revisions for This Edition (only for revised versions)

The list of revisions is a summary of points that have been revised or added to earlier versions. This does not include all of the revised contents. For details, see the actual locations in this manual.

11. Index

Preface

The SH7146 and SH7149 Group RISC (Reduced Instruction Set Computer) microcomputers include a Renesas original RISC CPU as its core, and the peripheral functions required to configure a system.

Target Users: This manual was written for users who will be using the SH7146 and SH7149 Group in the design of application systems. Target users are expected to understand the fundamentals of electrical circuits, logical circuits, and microcomputers.

Objective: This manual was written to explain the hardware functions and electrical characteristics of the SH7146 and SH7149 Group to the target users. Refer to the SH-1/SH-2/SH-DSP Software Manual for a detailed description of the instruction set.

Notes on reading this manual:

- In order to understand the overall functions of the chip
Read the manual according to the contents. This manual can be roughly categorized into parts on the CPU, system control functions, peripheral functions and electrical characteristics.
- In order to understand the details of the CPU's functions
Read the SH-1/SH-2/SH-DSP Software Manual.
- In order to understand the details of a register when its name is known
Read the index that is the final part of the manual to find the page number of the entry on the register. The addresses, bits, and initial values of the registers are summarized in section 23, List of Registers.

Examples:

Register name:	The following notation is used for cases when the same or a similar function, e.g. serial communication interface, is implemented on more than one channel: XXX_N (XXX is the register name and N is the channel number)
Bit order:	The MSB is on the left and the LSB is on the right.
Number notation:	Binary is B'xxxx, hexadecimal is H'xxxx, decimal is xxxx.
Signal notation:	An overbar is added to a low-active signal: $\overline{\text{xxxx}}$

Related Manuals: The latest versions of all related manuals are available from our web site. Please ensure you have the latest versions of all documents you require.
<http://www.renesas.com/>

SH7146 and SH7149 Group Manuals:

Document Title	Document No.
SH7146 Group Hardware Manual	This manual
SH-1/SH-2/SH-DSP Software Manual	REJ09B0171

User's Manuals for Development Tools:

Document Title	Document No.
SuperH™ RISC engine C/C++ Compiler, Assembler, Optimizing Linkage Editor Compiler Package V.9.00 User's Manual	REJ10B0152
SuperH™ RISC engine High-performance Embedded Workshop 3 User's Manual	REJ10B0025
SuperH RISC engine High-Performance Embedded Workshop 3 Tutorial	REJ10B0023

Application note:

Document Title	Document No.
SuperH RISC engine C/C++ Compiler Package Application Note	REJ05B0463

All trademarks and registered trademarks are the property of their respective owners.

Contents

Section 1 Overview	1
1.1 Features of SH7146 and SH7149	1
1.2 Block Diagram	6
1.3 Pin Assignments	7
1.4 Pin Functions	9
Section 2 CPU	15
2.1 Features	15
2.2 Register Configuration	16
2.2.1 General Registers (Rn)	17
2.2.2 Control Registers	17
2.2.3 System Registers	19
2.2.4 Initial Values of Registers	19
2.3 Data Formats	20
2.3.1 Register Data Format	20
2.3.2 Memory Data Formats	20
2.3.3 Immediate Data Formats	21
2.4 Features of Instructions	21
2.4.1 RISC Type	21
2.4.2 Addressing Modes	24
2.4.3 Instruction Formats	27
2.5 Instruction Set	31
2.5.1 Instruction Set by Type	31
2.5.2 Data Transfer Instructions	35
2.5.3 Arithmetic Operation Instructions	37
2.5.4 Logic Operation Instructions	39
2.5.5 Shift Instructions	40
2.5.6 Branch Instructions	41
2.5.7 System Control Instructions	42
2.6 Processing States	44
Section 3 MCU Operating Modes	47
3.1 Selection of Operating Modes	47
3.2 Input/Output Pins	48
3.3 Operating Modes	49
3.3.1 Mode 0 (MCU Extension Mode 0)	49
3.3.2 Mode 1 (MCU Extension Mode 1)	49

3.3.3	Mode 2 (MCU Extension Mode 2)	49
3.3.4	Mode 3 (Single Chip Mode)	49
3.4	Address Map	50
3.5	Initial State in This LSI	52
3.6	Note on Changing Operating Mode	52
Section 4 Clock Pulse Generator (CPG)		53
4.1	Features	53
4.2	Input/Output Pins	57
4.3	Clock Operating Mode	58
4.4	Register Descriptions	63
4.4.1	Frequency Control Register (FRQCR)	63
4.4.2	Oscillation Stop Detection Control Register (OSCCR)	66
4.5	Changing Frequency	67
4.6	Oscillator	68
4.6.1	Connecting Crystal Resonator	68
4.6.2	External Clock Input Method	69
4.7	Function for Detecting Oscillator Stop	70
4.8	Usage Notes	71
4.8.1	Note on Crystal Resonator	71
4.8.2	Notes on Board Design	71
Section 5 Exception Handling		73
5.1	Overview	73
5.1.1	Types of Exception Handling and Priority	73
5.1.2	Exception Handling Operations	74
5.1.3	Exception Handling Vector Table	75
5.2	Resets	77
5.2.1	Types of Resets	77
5.2.2	Power-On Reset	77
5.2.3	Manual Reset	78
5.3	Address Errors	79
5.3.1	Address Error Sources	79
5.3.2	Address Error Exception Source	80
5.4	Interrupts	81
5.4.1	Interrupt Sources	81
5.4.2	Interrupt Priority	82
5.4.3	Interrupt Exception Handling	82
5.5	Exceptions Triggered by Instructions	83
5.5.1	Types of Exceptions Triggered by Instructions	83

5.5.2	Trap Instructions	83
5.5.3	Illegal Slot Instructions	84
5.5.4	General Illegal Instructions	84
5.6	Cases when Exceptions Are Accepted	85
5.7	Stack States after Exception Handling Ends	86
5.8	Usage Notes	88
5.8.1	Value of Stack Pointer (SP)	88
5.8.2	Value of Vector Base Register (VBR)	88
5.8.3	Address Errors Caused by Stacking for Address Error Exception Handling	88
5.8.4	Notes on Slot Illegal Instruction Exception Handling	89
Section 6 Interrupt Controller (INTC)		91
6.1	Features	91
6.2	Input/Output Pins	93
6.3	Register Descriptions	94
6.3.1	Interrupt Control Register 0 (ICR0)	95
6.3.2	IRQ Control Register (IRQCR)	96
6.3.3	IRQ Status register (IRQSR)	98
6.3.4	Interrupt Priority Registers A, D to F, and H to L (IPRA, IPRD to IPRF, and IPRH to IPRL)	101
6.4	Interrupt Sources	104
6.4.1	External Interrupts	104
6.4.2	On-Chip Peripheral Module Interrupts	105
6.4.3	User Break Interrupt	105
6.5	Interrupt Exception Handling Vector Table	106
6.6	Interrupt Operation	109
6.6.1	Interrupt Sequence	109
6.6.2	Stack after Interrupt Exception Handling	112
6.7	Interrupt Response Time	112
6.8	Data Transfer with Interrupt Request Signals	114
6.8.1	Handling Interrupt Request Signals as Sources for DTC Activation and CPU Interrupts	115
6.8.2	Handling Interrupt Request Signals as Sources for DTC Activation, but Not CPU Interrupts	115
6.8.3	Handling Interrupt Request Signals as Sources for CPU Interrupts, but Not DTC Activation	116
6.9	Usage Note	116
Section 7 User Break Controller (UBC)		117
7.1	Features	117

7.2	Input/Output Pins.....	119
7.3	Register Descriptions.....	120
7.3.1	Break Address Register A (BARA).....	121
7.3.2	Break Address Mask Register A (BAMRA).....	121
7.3.3	Break Bus Cycle Register A (BBRA).....	122
7.3.4	Break Data Register A (BDRA) (F-ZTAT Version Only).....	124
7.3.5	Break Data Mask Register A (BDMRA) (F-ZTAT Version Only).....	125
7.3.6	Break Address Register B (BARB).....	126
7.3.7	Break Address Mask Register B (BAMRB).....	127
7.3.8	Break Data Register B (BDRB) (F-ZTAT Version Only).....	128
7.3.9	Break Data Mask Register B (BDMRB) (F-ZTAT Version Only).....	129
7.3.10	Break Bus Cycle Register B (BBRB).....	130
7.3.11	Break Control Register (BRCR).....	132
7.3.12	Execution Times Break Register (BETR) (F-ZTAT Version Only).....	137
7.3.13	Branch Source Register (BRSR) (F-ZTAT Version Only).....	138
7.3.14	Branch Destination Register (BRDR) (F-ZTAT Version Only).....	139
7.4	Operation.....	140
7.4.1	Flow of the User Break Operation.....	140
7.4.2	User Break on Instruction Fetch Cycle.....	141
7.4.3	User Break on Data Access Cycle.....	142
7.4.4	Sequential Break.....	143
7.4.5	Value of Saved Program Counter.....	143
7.4.6	PC Trace.....	144
7.4.7	Usage Examples.....	145
7.5	Usage Notes.....	150
Section 8 Data Transfer Controller (DTC).....		153
8.1	Features.....	153
8.2	Register Descriptions.....	155
8.2.1	DTC Mode Register A (MRA).....	156
8.2.2	DTC Mode Register B (MRB).....	157
8.2.3	DTC Source Address Register (SAR).....	159
8.2.4	DTC Destination Address Register (DAR).....	159
8.2.5	DTC Transfer Count Register A (CRA).....	160
8.2.6	DTC Transfer Count Register B (CRB).....	161
8.2.7	DTC Enable Registers A to E (DTCERA to DTCERE).....	162
8.2.8	DTC Control Register (DTCCR).....	163
8.2.9	DTC Vector Base Register (DTCVBR).....	165
8.2.10	Bus Function Extending Register (BSCEHR).....	165
8.3	Activation Sources.....	166

8.4	Location of Transfer Information and DTC Vector Table	166
8.5	Operation	170
8.5.1	Transfer Information Read Skip Function	175
8.5.2	Transfer Information Writeback Skip Function	176
8.5.3	Normal Transfer Mode	176
8.5.4	Repeat Transfer Mode.....	177
8.5.5	Block Transfer Mode	179
8.5.6	Chain Transfer	180
8.5.7	Operation Timing.....	182
8.5.8	Number of DTC Execution Cycles	185
8.5.9	DTC Bus Release Timing	187
8.5.10	DTC Activation Priority Order	190
8.6	DTC Activation by Interrupt.....	191
8.7	Examples of Use of the DTC	192
8.7.1	Normal Transfer Mode	192
8.7.2	Chain Transfer when Counter = 0.....	192
8.8	Interrupt Sources.....	194
8.9	Usage Notes	194
8.9.1	Module Standby Mode Setting	194
8.9.2	On-Chip RAM	194
8.9.3	DTCE Bit Setting.....	194
8.9.4	Chain Transfer	194
8.9.5	Transfer Information Start Address, Source Address, and Destination Address	194
8.9.6	Access to DTC Registers through DTC.....	195
8.9.7	Notes on IRQ Interrupt as DTC Activation Source	195
8.9.8	Notes on SCI as DTC Activation Sources	195
8.9.9	Clearing Interrupt Source Flag.....	195
8.9.10	Conflict between NMI Interrupt and DTC Activation	195
8.9.11	Operation When a DTC Activation Request Is Cancelled While in Progress.....	195
Section 9 Bus State Controller (BSC).....		197
9.1	Features.....	197
9.2	Input/Output Pins	199
9.3	Area Overview	199
9.3.1	Area Division	199
9.3.2	Address Map.....	199
9.4	Register Descriptions	203
9.4.1	Common Control Register (CMNCR)	203

9.4.2	CSn Space Bus Control Register (CSnBCR) (n = 0 and 1)	205
9.4.3	CSn Space Wait Control Register (CSnWCR) (n = 0 and 1).....	208
9.4.4	Bus Function Extending Register (BSCEHR)	210
9.5	Operation	214
9.5.1	Endian/Access Size and Data Alignment.....	214
9.5.2	Normal Space Interface.....	216
9.5.3	Access Wait Control	220
9.5.4	$\overline{\text{CSn}}$ Assert Period Extension	222
9.5.5	Wait between Access Cycles	223
9.5.6	Bus Arbitration	226
9.5.7	Others.....	230
9.5.8	Access to On-Chip FLASH and On-Chip RAM by CPU	231
9.5.9	Access to On-Chip Peripheral I/O Registers by CPU	231
9.5.10	Access to External Memory by CPU	233
Section 10 Multi-Function Timer Pulse Unit 2 (MTU2).....		237
10.1	Features.....	237
10.2	Input/Output Pins.....	243
10.3	Register Descriptions	244
10.3.1	Timer Control Register (TCR).....	248
10.3.2	Timer Mode Register (TMDR).....	252
10.3.3	Timer I/O Control Register (TIOR).....	255
10.3.4	Timer Compare Match Clear Register (TCNTCMPCLR).....	274
10.3.5	Timer Interrupt Enable Register (TIER).....	275
10.3.6	Timer Status Register (TSR).....	280
10.3.7	Timer Buffer Operation Transfer Mode Register (TBTM).....	288
10.3.8	Timer Input Capture Control Register (TICCR).....	289
10.3.9	Timer Synchronous Clear Register (TSYCR).....	291
10.3.10	Timer A/D Converter Start Request Control Register (TADCR)	293
10.3.11	Timer A/D Converter Start Request Cycle Set Registers (TADCORA_4 and TADCORB_4).....	296
10.3.12	Timer A/D Converter Start Request Cycle Set Buffer Registers (TADCOBRA_4 and TADCOBRB_4).....	296
10.3.13	Timer Counter (TCNT).....	297
10.3.14	Timer General Register (TGR)	297
10.3.15	Timer Start Register (TSTR)	298
10.3.16	Timer Synchronous Register (TSYR).....	300
10.3.17	Timer Counter Synchronous Start Register (TCSYSTR)	302
10.3.18	Timer Read/Write Enable Register (TRWER)	305
10.3.19	Timer Output Master Enable Register (TOER)	306

10.3.20	Timer Output Control Register 1 (TOCR1)	307
10.3.21	Timer Output Control Register 2 (TOCR2)	310
10.3.22	Timer Output Level Buffer Register (TOLBR)	313
10.3.23	Timer Gate Control Register (TGCR).....	314
10.3.24	Timer Subcounter (TCNTS)	316
10.3.25	Timer Dead Time Data Register (TDDR).....	317
10.3.26	Timer Cycle Data Register (TCDR)	317
10.3.27	Timer Cycle Buffer Register (TCBR).....	318
10.3.28	Timer Interrupt Skipping Set Register (TITCR)	318
10.3.29	Timer Interrupt Skipping Counter (TITCNT).....	320
10.3.30	Timer Buffer Transfer Set Register (TBTER)	321
10.3.31	Timer Dead Time Enable Register (TDER).....	323
10.3.32	Timer Waveform Control Register (TWCR)	324
10.3.33	Bus Master Interface	326
10.4	Operation	327
10.4.1	Basic Functions.....	327
10.4.2	Synchronous Operation.....	333
10.4.3	Buffer Operation.....	335
10.4.4	Cascaded Operation	339
10.4.5	PWM Modes	344
10.4.6	Phase Counting Mode	349
10.4.7	Reset-Synchronized PWM Mode.....	356
10.4.8	Complementary PWM Mode	359
10.4.9	A/D Converter Start Request Delaying Function.....	404
10.4.10	MTU2–MTU2S Synchronous Operation	408
10.4.11	External Pulse Width Measurement.....	414
10.4.12	Dead Time Compensation.....	415
10.4.13	TCNT Capture at Crest and/or Trough in Complementary PWM Operation ...	417
10.5	Interrupt Sources.....	418
10.5.1	Interrupt Sources and Priorities.....	418
10.5.2	DTC Activation.....	420
10.5.3	A/D Converter Activation.....	421
10.6	Operation Timing.....	423
10.6.1	Input/Output Timing	423
10.6.2	Interrupt Signal Timing.....	430
10.7	Usage Notes	435
10.7.1	Module Standby Mode Setting	435
10.7.2	Input Clock Restrictions	435
10.7.3	Caution on Period Setting	436
10.7.4	Contention between TCNT Write and Clear Operations.....	436

10.7.5	Contention between TCNT Write and Increment Operations.....	437
10.7.6	Contention between TGR Write and Compare Match.....	438
10.7.7	Contention between Buffer Register Write and Compare Match.....	439
10.7.8	Contention between Buffer Register Write and TCNT Clear.....	440
10.7.9	Contention between TGR Read and Input Capture.....	441
10.7.10	Contention between TGR Write and Input Capture.....	442
10.7.11	Contention between Buffer Register Write and Input Capture.....	443
10.7.12	TCNT_2 Write and Overflow/Underflow Contention in Cascade Connection.....	443
10.7.13	Counter Value during Complementary PWM Mode Stop.....	445
10.7.14	Buffer Operation Setting in Complementary PWM Mode.....	445
10.7.15	Reset Sync PWM Mode Buffer Operation and Compare Match Flag.....	446
10.7.16	Overflow Flags in Reset Synchronous PWM Mode.....	447
10.7.17	Contention between Overflow/Underflow and Counter Clearing.....	448
10.7.18	Contention between TCNT Write and Overflow/Underflow.....	449
10.7.19	Cautions on Transition from Normal Operation or PWM Mode 1 to Reset-Synchronized PWM Mode.....	449
10.7.20	Output Level in Complementary PWM Mode and Reset-Synchronized PWM Mode.....	450
10.7.21	Interrupts in Module Standby Mode.....	450
10.7.22	Simultaneous Capture of TCNT_1 and TCNT_2 in Cascade Connection.....	450
10.7.23	Notes on Output Waveform Control During Synchronous Counter Clearing in Complementary PWM Mode.....	451
10.8	MTU2 Output Pin Initialization.....	453
10.8.1	Operating Modes.....	453
10.8.2	Reset Start Operation.....	453
10.8.3	Operation in Case of Re-Setting Due to Error During Operation, etc.....	454
10.8.4	Overview of Initialization Procedures and Mode Transitions in Case of Error during Operation, etc.....	455
Section 11 Multi-Function Timer Pulse Unit 2S (MTU2S).....		485
11.1	Input/Output Pins.....	489
11.2	Register Descriptions.....	490
Section 12 Port Output Enable (POE).....		493
12.1	Features.....	493
12.2	Input/Output Pins.....	495
12.3	Register Descriptions.....	497
12.3.1	Input Level Control/Status Register 1 (ICSR1).....	498
12.3.2	Output Level Control/Status Register 1 (OCSR1).....	502

12.3.3	Input Level Control/Status Register 2 (ICSR2)	503
12.3.4	Output Level Control/Status Register 2 (OCSR2)	507
12.3.5	Input Level Control/Status Register 3 (ICSR3)	508
12.3.6	Software Port Output Enable Register (SPOER)	510
12.3.7	Port Output Enable Control Register 1 (POECR1).....	511
12.3.8	Port Output Enable Control Register 2 (POECR2).....	513
12.4	Operation	516
12.4.1	Input Level Detection Operation.....	517
12.4.2	Output-Level Compare Operation	518
12.4.3	Release from High-Impedance State.....	519
12.5	Interrupts.....	520
12.6	Usage Note.....	521
12.6.1	Pin State When a Power-On Reset Is Issued from the Watchdog Timer	521
Section 13 Watchdog Timer (WDT).....		523
13.1	Features.....	523
13.2	Input/Output Pin for WDT.....	525
13.3	Register Descriptions	526
13.3.1	Watchdog Timer Counter (WTCNT).....	526
13.3.2	Watchdog Timer Control/Status Register (WTCSR).....	527
13.3.3	Notes on Register Access.....	529
13.4	Operation	530
13.4.1	Revoking Software Standbys.....	530
13.4.2	Using Watchdog Timer Mode.....	530
13.4.3	Using Interval Timer Mode.....	531
13.5	Interrupt Source	532
13.6	Usage Note.....	532
13.6.1	WTCNT Setting Value	532
Section 14 Serial Communication Interface (SCI)		533
14.1	Features.....	533
14.2	Input/Output Pins	535
14.3	Register Descriptions	536
14.3.1	Receive Shift Register (SCRSR).....	537
14.3.2	Receive Data Register (SCRDR)	537
14.3.3	Transmit Shift Register (SCTSR)	537
14.3.4	Transmit Data Register (SCTDR).....	538
14.3.5	Serial Mode Register (SCSMR).....	538
14.3.6	Serial Control Register (SCSCR).....	541
14.3.7	Serial Status Register (SCSSR).....	544

14.3.8	Serial Port Register (SCSPTR)	550
14.3.9	Serial Direction Control Register (SCSDCR)	552
14.3.10	Bit Rate Register (SCBRR)	553
14.4	Operation	564
14.4.1	Overview	564
14.4.2	Operation in Asynchronous Mode	566
14.4.3	Clock Synchronous Mode	576
14.4.4	Multiprocessor Communication Function	585
14.4.5	Multiprocessor Serial Data Transmission	586
14.4.6	Multiprocessor Serial Data Reception	588
14.5	SCI Interrupt Sources and DTC	591
14.6	Serial Port Register (SCSPTR) and SCI Pins	592
14.7	Usage Notes	594
14.7.1	SCTDR Writing and TDRE Flag	594
14.7.2	Multiple Receive Error Occurrence	594
14.7.3	Break Detection and Processing	595
14.7.4	Sending a Break Signal	595
14.7.5	Receive Data Sampling Timing and Receive Margin (Asynchronous Mode) ..	595
14.7.6	Note on Using DTC	597
14.7.7	Note on Using External Clock in Clock Synchronous Mode	597
14.7.8	Module Standby Mode Setting	597
Section 15 A/D Converter (ADC)		599
15.1	Features	599
15.2	Input/Output Pins	601
15.3	Register Descriptions	602
15.3.1	A/D Data Registers 0, 2, 4, 6, and 8 to 15 (ADDR0, ADDR2, ADDR4, ADDR6, and ADDR8 to ADDR15)	603
15.3.2	A/D Control/Status Registers_0 to _2 (ADCSR_0 to ADCSR_2)	604
15.3.3	A/D Control Registers_0 to _2 (ADCR_0 to ADCR_2)	607
15.3.4	A/D Trigger Select Registers_0 and _1 (ADTSR_0 and ADTSR_1)	610
15.4	Operation	616
15.4.1	Single Mode	616
15.4.2	Continuous Scan Mode	616
15.4.3	Single-Cycle Scan Mode	617
15.4.4	Input Sampling and A/D Conversion Time	617
15.4.5	A/D Converter Activation by MTU2 or MTU2S	620
15.4.6	External Trigger Input Timing	620
15.4.7	2-Channel Scanning	621
15.5	Interrupt Sources and DTC Transfer Request	622

15.6	Definitions of A/D Conversion Accuracy.....	623
15.7	Usage Notes	626
15.7.1	Module Standby Mode Setting	626
15.7.2	Permissible Signal Source Impedance	626
15.7.3	Influences on Absolute Accuracy	626
15.7.4	Range of Analog Power Supply and Other Pin Settings.....	627
15.7.5	Notes on Board Design	627
15.7.6	Notes on Noise Countermeasures	628
Section 16 Compare Match Timer (CMT).....		629
16.1	Features.....	629
16.2	Register Descriptions	630
16.2.1	Compare Match Timer Start Register (CMSTR)	631
16.2.2	Compare Match Timer Control/Status Register (CMCSR)	631
16.2.3	Compare Match Counter (CMCNT)	633
16.2.4	Compare Match Constant Register (CMCOR)	633
16.3	Operation	634
16.3.1	Interval Count Operation	634
16.3.2	CMCNT Count Timing.....	634
16.4	Interrupts.....	635
16.4.1	CMT Interrupt Sources and DTC Activation.....	635
16.4.2	Timing of Setting Compare Match Flag	635
16.4.3	Timing of Clearing Compare Match Flag.....	636
16.5	Usage Notes	637
16.5.1	Module Standby Mode Setting	637
16.5.2	Conflict between Write and Compare-Match Processes of CMCNT	637
16.5.3	Conflict between Word-Write and Count-Up Processes of CMCNT	638
16.5.4	Conflict between Byte-Write and Count-Up Processes of CMCNT.....	639
16.5.5	Compare Match between CMCNT and CMCOR	639
Section 17 Pin Function Controller (PFC).....		641
17.1	Register Descriptions	658
17.1.1	Port A I/O Register L (PAIORL).....	659
17.1.2	Port A Control Registers L1 to L4 (PACRL1 to PACRL4).....	659
17.1.3	Port B I/O Register L, H (PBIORL, PBIORH).....	673
17.1.4	Port B Control Registers L1, L2, H1 (PBCRL1, PBCRL2, PBCRH1).....	674
17.1.5	Port D I/O Register L (PDIORL) (SH7149 Only)	681
17.1.6	Port D Control Registers L1 to L4 (PDCRL1 to PDCRL4) (SH7149 Only)	681
17.1.7	Port E I/O Registers L, H (PEIORL, PEIORH)	688

17.1.8	Port E Control Registers L1 to L4, H1, H2 (PECRL1 to PECRL4, PECRH1, PECRH2).....	689
17.1.9	IRQOUT Function Control Register (IFCR)	706
17.2	Usage Notes	707
Section 18 I/O Ports.....		709
18.1	Port A.....	710
18.1.1	Register Descriptions	712
18.1.2	Port A Data Register L (PADRL).....	712
18.1.3	Port A Port Register L (PAPRL)	714
18.2	Port B.....	715
18.2.1	Register Descriptions	716
18.2.2	Port B Data Registers H and L (PBDRH and PBDRL)	716
18.2.3	Port B Port Registers H and L (PBPRH and PBPRL).....	719
18.3	Port D (SH7149 Only).....	721
18.3.1	Register Descriptions	722
18.3.2	Port D Data Register L (PDDRL).....	722
18.3.3	Port D Port Register L (PDPRL)	724
18.4	Port E	725
18.4.1	Register Descriptions	727
18.4.2	Port E Data Registers H and L (PEDRH and PEDRL)	727
18.4.3	Port E Port Registers H and L (PEPRH and PEPRL)	730
18.5	Port F	732
18.5.1	Register Descriptions	733
18.5.2	Port F Data Register L (PFDRL)	733
Section 19 Flash Memory.....		735
19.1	Features.....	735
19.2	Overview	737
19.2.1	Block Diagram.....	737
19.2.2	Operating Mode	738
19.2.3	Mode Comparison.....	740
19.2.4	Flash Memory Configuration.....	741
19.2.5	Block Division	742
19.2.6	Programming/Erasing Interface	742
19.3	Input/Output Pins.....	745
19.4	Register Descriptions	745
19.4.1	Registers	745
19.4.2	Programming/Erasing Interface Registers	748
19.4.3	Programming/Erasing Interface Parameters	755

19.4.4	RAM Emulation Register (RAMER).....	770
19.5	On-Board Programming Mode	772
19.5.1	Boot Mode	772
19.5.2	User Program Mode.....	776
19.5.3	User Boot Mode.....	785
19.6	Protection.....	790
19.6.1	Hardware Protection	790
19.6.2	Software Protection.....	791
19.6.3	Error Protection.....	791
19.7	Flash Memory Emulation in RAM	793
19.8	Usage Notes	796
19.8.1	Switching between User MAT and User Boot MAT.....	796
19.8.2	Interrupts during Programming/Erasing	797
19.8.3	Other Notes	800
19.9	Supplementary Information	802
19.9.1	Specifications of the Standard Serial Communications Interface in Boot Mode	802
19.9.2	Areas for Storage of the Procedural Program and Data for Programming.....	832
19.10	Programmer Mode	840
Section 20 Masked ROM.....		841
20.1	Usage Note.....	842
20.1.1	Module Standby Mode Setting	842
Section 21 RAM		843
21.1	Usage Notes	844
21.1.1	Module Standby Mode Setting	844
21.1.2	Address Error.....	844
21.1.3	Initial Values in RAM.....	844
Section 22 Power-Down Modes		845
22.1	Features.....	845
22.1.1	Types of Power-Down Modes	845
22.2	Input/Output Pins.....	847
22.3	Register Descriptions	848
22.3.1	Standby Control Register 1 (STBCR1).....	848
22.3.2	Standby Control Register 2 (STBCR2).....	849
22.3.3	Standby Control Register 3 (STBCR3).....	850
22.3.4	Standby Control Register 4 (STBCR4).....	851
22.3.5	Standby Control Register 5 (STBCR5).....	853

22.3.6	Standby Control Register 6 (STBCR6).....	854
22.3.7	RAM Control Register (RAMCR).....	855
22.4	Sleep Mode.....	856
22.4.1	Transition to Sleep Mode.....	856
22.4.2	Canceling Sleep Mode.....	856
22.5	Software Standby Mode.....	857
22.5.1	Transition to Software Standby Mode.....	857
22.5.2	Canceling Software Standby Mode.....	858
22.6	Deep Software Standby Mode.....	859
22.6.1	Transition to Deep Software Standby Mode.....	859
22.6.2	Canceling Deep Software Standby Mode.....	859
22.7	Module Standby Mode.....	860
22.7.1	Transition to Module Standby Mode.....	860
22.7.2	Canceling Module Standby Function.....	860
22.8	Usage Note.....	861
22.8.1	Current Consumption while Waiting for Oscillation to be Stabilized.....	861
22.8.2	Executing the SLEEP Instruction.....	861
Section 23 List of Registers.....		863
23.1	Register Address Table (In the Order from Lower Addresses).....	864
23.2	Register Bit List.....	876
23.3	Register States in Each Operating Mode.....	894
Section 24 Electrical Characteristics.....		905
24.1	Absolute Maximum Ratings.....	905
24.2	DC Characteristics.....	906
24.3	AC Characteristics.....	910
24.3.1	Clock Timing.....	911
24.3.2	Control Signal Timing.....	914
24.3.3	AC Bus Timing.....	917
24.3.4	Multi Function Timer Pulse Unit 2 (MTU2) Timing.....	923
24.3.5	Multi Function Timer Pulse Unit 2S (MTU2S) Timing.....	924
24.3.6	I/O Port Timing.....	925
24.3.7	Watchdog Timer (WDT) Timing.....	926
24.3.8	Serial Communication Interface (SCI) Timing.....	927
24.3.9	Port Output Enable (POE) Timing.....	929
24.3.10	UBC Trigger Timing.....	930
24.3.11	A/D Converter Timing.....	931
24.3.12	AC Characteristics Measurement Conditions.....	932
24.4	A/D Converter Characteristics.....	933

24.5	Flash Memory Characteristics	934
24.6	Usage Note.....	935
24.6.1	Notes on Connecting V_{CL} Capacitor	935
	Appendix.....	937
A.	Pin States	937
B.	Processing of Unused Pins.....	943
C.	Pin States of Bus Related Signals	944
D.	Product Code Lineup	946
E.	Package Dimensions	947
	Main Revisions for This Edition.....	949
	Index	959

Figures

Section 1 Overview

Figure 1.1	Block Diagram.....	6
Figure 1.2	Pin Assignments of SH7146.....	7
Figure 1.3	Pin Assignments of SH7149 (LQFP Version).....	8

Section 2 CPU

Figure 2.1	CPU Internal Register Configuration.....	16
Figure 2.2	Register Data Format.....	20
Figure 2.3	Memory Data Format.....	20
Figure 2.4	Transitions between Processing States.....	44

Section 3 MCU Operating Modes

Figure 3.1	Address Map for Each Operating Mode in SH7146.....	50
Figure 3.2	Address Map for Each Operating Mode in SH7149.....	51
Figure 3.3	Reset Input Timing when Changing Operating Mode.....	52

Section 4 Clock Pulse Generator (CPG)

Figure 4.1	Block Diagram of Clock Pulse Generator.....	54
Figure 4.2	Connection of Crystal Resonator (Example).....	68
Figure 4.3	Crystal Resonator Equivalent Circuit.....	68
Figure 4.4	Example of External Clock Connection.....	69
Figure 4.5	Cautions for Oscillator Circuit Board Design.....	71
Figure 4.6	Recommended External Circuitry around PLL.....	72

Section 6 Interrupt Controller (INTC)

Figure 6.1	Block Diagram of INTC.....	92
Figure 6.2	Block Diagram of IRQ3 to IRQ0 Interrupts Control.....	105
Figure 6.3	Interrupt Sequence Flowchart.....	111
Figure 6.4	Stack after Interrupt Exception Handling.....	112
Figure 6.5	IRQ Interrupt Control Block Diagram.....	114
Figure 6.6	On-Chip Module Interrupt Control Block Diagram.....	115

Section 7 User Break Controller (UBC)

Figure 7.1	Block Diagram of UBC.....	118
------------	---------------------------	-----

Section 8 Data Transfer Controller (DTC)

Figure 8.1	Block Diagram of DTC.....	154
------------	---------------------------	-----

Figure 8.2	Transfer Information on Data Area.....	167
Figure 8.3	Correspondence between DTC Vector Address and Transfer Information	167
Figure 8.4	Flowchart of DTC Operation.....	171
Figure 8.5	Transfer Information Read Skip Timing (Activated by On-Chip Peripheral Module; I ϕ : B ϕ : P ϕ =1: 1/2: 1/2; Data Transferred from On-Chip Peripheral Module to On-Chip RAM; Transfer Information Is Written in 3 States).....	175
Figure 8.6	Memory Map in Normal Transfer Mode	177
Figure 8.7	Memory Map in Repeat Transfer Mode (When Transfer Source Is Specified as Repeat Area).....	178
Figure 8.8	Memory Map in Block Transfer Mode (When Transfer Destination Is Specified as Block Area).....	180
Figure 8.9	Operation of Chain Transfer.....	181
Figure 8.10	Example of DTC Operation Timing: Normal Transfer Mode or Repeat Transfer Mode (Activated by On-Chip Peripheral Module; I ϕ : B ϕ : P ϕ =1: 1/2: 1/2; Data Transferred from On-Chip Peripheral Module to On-Chip RAM; Transfer Information Is Written in 3 Cycles).....	182
Figure 8.11	Example of DTC Operation Timing: Block Transfer Mode with Block Size = 2 (Activated by On-Chip Peripheral Module; I ϕ : B ϕ : P ϕ =1: 1/2: 1/2; Data Transferred from On-Chip Peripheral Module to On-Chip RAM; Transfer Information Is Written in 3 Cycles).....	182
Figure 8.12	Example of DTC Operation Timing: Chain Transfer (Activated by On-Chip Peripheral Module; I ϕ : B ϕ : P ϕ =1: 1/2: 1/2; Data Transferred from On-Chip Peripheral Module to On-Chip RAM; Transfer Information Is Written in 3 Cycles).....	183
Figure 8.13	Example of DTC Operation Timing: Normal or Repeat Transfer in Short Address Mode (Activated by On-Chip Peripheral Module; I ϕ : B ϕ : P ϕ =1: 1/2: 1/2; Data Transferred from On-Chip Peripheral Module to On-Chip RAM; Transfer Information Is Written in 3 Cycles).....	183
Figure 8.14	Example of DTC Operation Timing: Normal or Repeat Transfer with DTPR = 1 (Activated by On-Chip Peripheral Module; I ϕ : B ϕ : P ϕ =1: 1/2: 1/2; Data Transferred from On-Chip Peripheral Module to On-Chip RAM; Transfer Information Is Written in 3 Cycles).....	184
Figure 8.15	Example of DTC Operation Timing: Normal or Repeat Transfer (Activated by IRQ; I ϕ : B ϕ : P ϕ =1: 1/2: 1/2; Data Transferred from On-Chip Peripheral Module to On-Chip RAM; Transfer Information Is Written in 3 Cycles).....	184
Figure 8.16	Example of DTC Operation Timing: Conflict of Two Activation Requests in Normal Transfer Mode (Activated by On-Chip Peripheral Module; I ϕ : B ϕ : P ϕ = 1: 1/2: 1/2; Data Transferred from On-Chip Peripheral Module to On-Chip RAM; Transfer Information Is Written in 3 Cycles).....	189

Figure 8.17	Example of DTC Activation in Accordance with Priority	190
Figure 8.18	Activation of DTC by Interrupt	191
Figure 8.19	Chain Transfer when Counter = 0.....	193

Section 9 Bus State Controller (BSC)

Figure 9.1	Block Diagram of BSC	198
Figure 9.2	Normal Space Basic Access Timing (Access Wait 0)	216
Figure 9.3	Continuous Access for Normal Space 1 Bus Width = 16 Bits, Longword Access, WM Bit in CSnWCR = 0 (Access Wait = 0, Cycle Wait = 0).....	217
Figure 9.4	Continuous Access for Normal Space 2 Bus Width = 16 Bits, Longword Access, WM Bit in CSnWCR = 1 (Access Wait = 0, Cycle Wait = 0).....	218
Figure 9.5	Example of 16-Bit Data-Width SRAM Connection	219
Figure 9.6	Example of 8-Bit Data-Width SRAM Connection	219
Figure 9.7	Wait Timing for Normal Space Access (Software Wait Only).....	220
Figure 9.8	Wait State Timing for Normal Space Access (Wait State Insertion Using WAIT Signal).....	221
Figure 9.9	CSn Assert Period Extension	222
Figure 9.10	Bus Arbitration When DTC Activation Request Occur during External Space Access from CPU.....	227
Figure 9.11	Bus Arbitration Timing.....	229
Figure 9.12	Timing of Write Access to On-Chip Peripheral I/O Registers When I ϕ :B ϕ :P ϕ = 4:2:2.....	232
Figure 9.13	Timing of Read Access to On-Chip Peripheral I/O Registers When I ϕ :B ϕ :P ϕ = 4:2:1.....	232
Figure 9.14	Timing of Write Access to Word Data in External Memory When I ϕ :B ϕ = 2:1 and External Bus Width is 8 Bits.....	234
Figure 9.15	Timing of Read Access with Condition I ϕ :B ϕ = 4:1 and External Bus Width \geq Data Width	235

Section 10 Multi-Function Timer Pulse Unit 2 (MTU2)

Figure 10.1	Block Diagram of MTU2.....	242
Figure 10.2	Complementary PWM Mode Output Level Example.....	309
Figure 10.3	PWM Output Level Setting Procedure in Buffer Operation	314
Figure 10.4	Example of Counter Operation Setting Procedure.....	327
Figure 10.5	Free-Running Counter Operation.....	328
Figure 10.6	Periodic Counter Operation	329
Figure 10.7	Example of Setting Procedure for Waveform Output by Compare Match	329
Figure 10.8	Example of 0 Output/1 Output Operation.....	330
Figure 10.9	Example of Toggle Output Operation.....	330
Figure 10.10	Example of Input Capture Operation Setting Procedure.....	331

Figure 10.11	Example of Input Capture Operation	332
Figure 10.12	Example of Synchronous Operation Setting Procedure	333
Figure 10.13	Example of Synchronous Operation	334
Figure 10.14	Compare Match Buffer Operation	335
Figure 10.15	Input Capture Buffer Operation	336
Figure 10.16	Example of Buffer Operation Setting Procedure	336
Figure 10.17	Example of Buffer Operation (1)	337
Figure 10.18	Example of Buffer Operation (2)	338
Figure 10.19	Example of Buffer Operation When TCNT_0 Clearing Is Selected for TGRC_0 to TGRA_0 Transfer Timing	339
Figure 10.20	Cascaded Operation Setting Procedure	340
Figure 10.21	Cascaded Operation Example (a)	341
Figure 10.22	Cascaded Operation Example (b)	341
Figure 10.23	Cascaded Operation Example (c)	342
Figure 10.24	Cascaded Operation Example (d)	343
Figure 10.25	Example of PWM Mode Setting Procedure	346
Figure 10.26	Example of PWM Mode Operation (1)	347
Figure 10.27	Example of PWM Mode Operation (2)	347
Figure 10.28	Example of PWM Mode Operation (3)	348
Figure 10.29	Example of Phase Counting Mode Setting Procedure	349
Figure 10.30	Example of Phase Counting Mode 1 Operation	350
Figure 10.31	Example of Phase Counting Mode 2 Operation	351
Figure 10.32	Example of Phase Counting Mode 3 Operation	352
Figure 10.33	Example of Phase Counting Mode 4 Operation	353
Figure 10.34	Phase Counting Mode Application Example	355
Figure 10.35	Procedure for Selecting Reset-Synchronized PWM Mode	357
Figure 10.36	Reset-Synchronized PWM Mode Operation Example (When TOCR's OLSN = 1 and OLSP = 1)	358
Figure 10.37	Block Diagram of Channels 3 and 4 in Complementary PWM Mode	361
Figure 10.38	Example of Complementary PWM Mode Setting Procedure	362
Figure 10.39	Complementary PWM Mode Counter Operation	363
Figure 10.40	Example of Complementary PWM Mode Operation	365
Figure 10.41	Example of Operation without Dead Time	368
Figure 10.42	Example of PWM Cycle Updating	369
Figure 10.43	Example of Data Update in Complementary PWM Mode	371
Figure 10.44	Example of Initial Output in Complementary PWM Mode (1)	372
Figure 10.45	Example of Initial Output in Complementary PWM Mode (2)	373
Figure 10.46	Example of Complementary PWM Mode Waveform Output (1)	375
Figure 10.47	Example of Complementary PWM Mode Waveform Output (2)	375
Figure 10.48	Example of Complementary PWM Mode Waveform Output (3)	376

Figure 10.49	Example of Complementary PWM Mode 0% and 100% Waveform Output (1)..	376
Figure 10.50	Example of Complementary PWM Mode 0% and 100% Waveform Output (2)..	377
Figure 10.51	Example of Complementary PWM Mode 0% and 100% Waveform Output (3)..	377
Figure 10.52	Example of Complementary PWM Mode 0% and 100% Waveform Output (4)..	378
Figure 10.53	Example of Complementary PWM Mode 0% and 100% Waveform Output (5)..	378
Figure 10.54	Example of Toggle Output Waveform Synchronized with PWM Output	379
Figure 10.55	Counter Clearing Synchronized with Another Channel.....	380
Figure 10.56	Timing for Synchronous Counter Clearing.....	382
Figure 10.57	Example of Procedure for Setting Output Waveform Control at Synchronous Counter Clearing in Complementary PWM Mode	383
Figure 10.58	Example of Synchronous Clearing in Dead Time during Up-Counting (Timing (3) in Figure 10.56; Bit WRE of TWCR in MTU2 Is 1).....	384
Figure 10.59	Example of Synchronous Clearing in Interval Tb at Crest (Timing (6) in Figure 10.56; Bit WRE of TWCR in MTU2 Is 1).....	384
Figure 10.60	Example of Synchronous Clearing in Dead Time during Down-Counting (Timing (8) in Figure 10.56; Bit WRE of TWCR Is 1).....	385
Figure 10.61	Example of Synchronous Clearing in Interval Tb at Trough (Timing (11) in Figure 10.56; Bit WRE of TWCR Is 1).....	386
Figure 10.62	MTU2–MTU2S Synchronous Clearing–Suppressed Interval Specified by SCC Bit in TWCR	387
Figure 10.63	Example of Procedure for Suppressing MTU2–MTU2S Synchronous Counter Clearing.....	388
Figure 10.64	Example of Synchronous Clearing in Dead Time during Up-Counting (Timing (3) in Figure 10.56; Bit WRE Is 1 and Bit SCC Is 1 in TWCR of MTU2S)	389
Figure 10.65	Example of Synchronous Clearing in Interval Tb at Crest (Timing (6) in Figure 10.56; Bit WRE Is 1 and Bit SCC Is 1 in TWCR of MTU2S)	390
Figure 10.66	Example of Synchronous Clearing in Dead Time during Down-Counting (Timing (8) in Figure 10.56; Bit WRE Is 1 and Bit SCC Is 1 in TWCR of MTU2S)	391
Figure 10.67	Example of Synchronous Clearing in Interval Tb at Trough (Timing (11) in Figure 10.56; Bit WRE Is 1 and Bit SCC Is 1 in TWCR of MTU2S)	392
Figure 10.68	Example of Counter Clearing Operation by TGRA_3 Compare Match	393
Figure 10.69	Example of Output Phase Switching by External Input (1)	394
Figure 10.70	Example of Output Phase Switching by External Input (2)	395
Figure 10.71	Example of Output Phase Switching by Means of UF, VF, WF Bit Settings (1) .	395
Figure 10.72	Example of Output Phase Switching by Means of UF, VF, WF Bit Settings (2) .	396
Figure 10.73	Example of Interrupt Skipping Operation Setting Procedure	397
Figure 10.74	Periods during which Interrupt Skipping Count Can be Changed	398

Figure 10.75	Example of Interrupt Skipping Operation.....	398
Figure 10.76	Example of Operation when Buffer Transfer Is Suppressed (BTE1 = 0 and BTE0 = 1)	400
Figure 10.77	Example of Operation when Buffer Transfer Is Linked with Interrupt Skipping (BTE1 = 1 and BTE0 = 0)	401
Figure 10.78	Relationship between Bits T3AEN and T4VEN in TITCR and Buffer Transfer-Enabled Period.....	402
Figure 10.79	Example of Procedure for Specifying A/D Converter Start Request Delaying Function	404
Figure 10.80	Basic Example of A/D Converter Start Request Signal (TRG4AN) Operation....	405
Figure 10.81	Example of A/D Converter Start Request Signal (TRG4AN) Operation Linked with Interrupt Skipping.....	406
Figure 10.82	Example of A/D Converter Start Request Signal (TRG4AN) Operation Linked with Interrupt Skipping.....	407
Figure 10.83	Example of Synchronous Counter Start Setting Procedure	408
Figure 10.84 (1)	Example of Synchronous Counter Start Operation (MTU2-to-MTU2S Clock Frequency Ratio = 1:1).....	409
Figure 10.84 (2)	Example of Synchronous Counter Start Operation (MTU2-to-MTU2S Clock Frequency Ratio = 1:2).....	410
Figure 10.84 (3)	Example of Synchronous Counter Start Operation (MTU2-to-MTU2S Clock Frequency Ratio = 1:3).....	410
Figure 10.84 (4)	Example of Synchronous Counter Start Operation (MTU2-to-MTU2S Clock Frequency Ratio = 1:4).....	411
Figure 10.85	Example of Procedure for Specifying MTU2S Counter Clearing by MTU2 Flag Setting Source	412
Figure 10.86 (1)	Example of MTU2S Counter Clearing Caused by MTU2 Flag Setting Source (1)	413
Figure 10.86 (2)	Example of MTU2S Counter Clearing Caused by MTU2 Flag Setting Source (2).....	413
Figure 10.87	Example of External Pulse Width Measurement Setting Procedure.....	414
Figure 10.88	Example of External Pulse Width Measurement (Measuring High Pulse Width)	414
Figure 10.89	Delay in Dead Time in Complementary PWM Operation.....	415
Figure 10.90	Example of Dead Time Compensation Setting Procedure.....	416
Figure 10.91	Example of Motor Control Circuit Configuration	416
Figure 10.92	TCNT Capturing at Crest and/or Trough in Complementary PWM Operation	417
Figure 10.93	Count Timing in Internal Clock Operation (Channels 0 to 4).....	423
Figure 10.94	Count Timing in Internal Clock Operation (Channel 5)	423
Figure 10.95	Count Timing in External Clock Operation (Channels 0 to 4)	423
Figure 10.96	Count Timing in External Clock Operation (Phase Counting Mode).....	424
Figure 10.97	Output Compare Output Timing (Normal Mode/PWM Mode).....	424

Figure 10.98	Output Compare Output Timing (Complementary PWM Mode/ Reset Synchronous PWM Mode).....	425
Figure 10.99	Input Capture Input Signal Timing	425
Figure 10.100	Counter Clear Timing (Compare Match) (Channels 0 to 4)	426
Figure 10.101	Counter Clear Timing (Compare Match) (Channel 5).....	426
Figure 10.102	Counter Clear Timing (Input Capture) (Channels 0 to 5)	427
Figure 10.103	Buffer Operation Timing (Compare Match).....	427
Figure 10.104	Buffer Operation Timing (Input Capture).....	427
Figure 10.105	Buffer Transfer Timing (when TCNT Cleared).....	428
Figure 10.106	Transfer Timing from Buffer Register to Temporary Register (TCNTS Stop)	428
Figure 10.107	Transfer Timing from Buffer Register to Temporary Register (TCNTS Operating)	429
Figure 10.108	Transfer Timing from Temporary Register to Compare Register.....	429
Figure 10.109	TGI Interrupt Timing (Compare Match) (Channels 0 to 4)	430
Figure 10.110	TGI Interrupt Timing (Compare Match) (Channel 5).....	430
Figure 10.111	TGI Interrupt Timing (Input Capture) (Channels 0 to 4).....	431
Figure 10.112	TGI Interrupt Timing (Input Capture) (Channel 5).....	431
Figure 10.113	TCIV Interrupt Setting Timing	432
Figure 10.114	TCIU Interrupt Setting Timing	432
Figure 10.115	Timing for Status Flag Clearing by CPU (Channels 0 to 4)	433
Figure 10.116	Timing for Status Flag Clearing by CPU (Channel 5).....	433
Figure 10.117	Timing for Status Flag Clearing by DTC Activation (Channels 0 to 4)	434
Figure 10.118	Timing for Status Flag Clearing by DTC Activation (Channel 5).....	434
Figure 10.119	Phase Difference, Overlap, and Pulse Width in Phase Counting Mode.....	435
Figure 10.120	Contention between TCNT Write and Clear Operations	436
Figure 10.121	Contention between TCNT Write and Increment Operations.....	437
Figure 10.122	Contention between TGR Write and Compare Match	438
Figure 10.123	Contention between Buffer Register Write and Compare Match	439
Figure 10.124	Contention between Buffer Register Write and TCNT Clear	440
Figure 10.125	Contention between TGR Read and Input Capture (Channels 0 to 4)	441
Figure 10.126	Contention between TGR Read and Input Capture (Channel 5).....	441
Figure 10.127	Contention between TGR Write and Input Capture (Channels 0 to 4)	442
Figure 10.128	Contention between TGR Write and Input Capture (Channel 5).....	442
Figure 10.129	Contention between Buffer Register Write and Input Capture	443
Figure 10.130	TCNT_2 Write and Overflow/Underflow Contention with Cascade Connection.....	444
Figure 10.131	Counter Value during Complementary PWM Mode Stop	445
Figure 10.132	Buffer Operation and Compare-Match Flags in Reset Synchronous PWM Mode.....	446
Figure 10.133	Reset Synchronous PWM Mode Overflow Flag.....	447

Figure 10.134 Contention between Overflow and Counter Clearing	448
Figure 10.135 Contention between TCNT Write and Overflow	449
Figure 10.136 Condition (1) Synchronous Clearing Example	451
Figure 10.137 Condition (2) Synchronous Clearing Example	452
Figure 10.138 Error Occurrence in Normal Mode, Recovery in Normal Mode	456
Figure 10.139 Error Occurrence in Normal Mode, Recovery in PWM Mode 1	457
Figure 10.140 Error Occurrence in Normal Mode, Recovery in PWM Mode 2	458
Figure 10.141 Error Occurrence in Normal Mode, Recovery in Phase Counting Mode	459
Figure 10.142 Error Occurrence in Normal Mode, Recovery in Complementary PWM Mode	460
Figure 10.143 Error Occurrence in Normal Mode, Recovery in Reset-Synchronized PWM Mode	461
Figure 10.144 Error Occurrence in PWM Mode 1, Recovery in Normal Mode	462
Figure 10.145 Error Occurrence in PWM Mode 1, Recovery in PWM Mode 1	463
Figure 10.146 Error Occurrence in PWM Mode 1, Recovery in PWM Mode 2	464
Figure 10.147 Error Occurrence in PWM Mode 1, Recovery in Phase Counting Mode	465
Figure 10.148 Error Occurrence in PWM Mode 1, Recovery in Complementary PWM Mode	466
Figure 10.149 Error Occurrence in PWM Mode 1, Recovery in Reset-Synchronized PWM Mode	467
Figure 10.150 Error Occurrence in PWM Mode 2, Recovery in Normal Mode	468
Figure 10.151 Error Occurrence in PWM Mode 2, Recovery in PWM Mode 1	469
Figure 10.152 Error Occurrence in PWM Mode 2, Recovery in PWM Mode 2	470
Figure 10.153 Error Occurrence in PWM Mode 2, Recovery in Phase Counting Mode	471
Figure 10.154 Error Occurrence in Phase Counting Mode, Recovery in Normal Mode	472
Figure 10.155 Error Occurrence in Phase Counting Mode, Recovery in PWM Mode 1	473
Figure 10.156 Error Occurrence in Phase Counting Mode, Recovery in PWM Mode 2	474
Figure 10.157 Error Occurrence in Phase Counting Mode, Recovery in Phase Counting Mode	475
Figure 10.158 Error Occurrence in Complementary PWM Mode, Recovery in Normal Mode	476
Figure 10.159 Error Occurrence in Complementary PWM Mode, Recovery in PWM Mode 1	477
Figure 10.160 Error Occurrence in Complementary PWM Mode, Recovery in Complementary PWM Mode	478
Figure 10.161 Error Occurrence in Complementary PWM Mode, Recovery in Complementary PWM Mode	479
Figure 10.162 Error Occurrence in Complementary PWM Mode, Recovery in Reset-Synchronized PWM Mode	480

Figure 10.163 Error Occurrence in Reset-Synchronized PWM Mode, Recovery in Normal Mode.....	481
Figure 10.164 Error Occurrence in Reset-Synchronized PWM Mode, Recovery in PWM Mode 1	482
Figure 10.165 Error Occurrence in Reset-Synchronized PWM Mode, Recovery in Complementary PWM Mode.....	483
Figure 10.166 Error Occurrence in Reset-Synchronized PWM Mode, Recovery in Reset-Synchronized PWM Mode	484

Section 12 Port Output Enable (POE)

Figure 12.1 Block Diagram of POE.....	494
Figure 12.2 Falling Edge Detection	517
Figure 12.3 Low-Level Detection Operation	518
Figure 12.4 Output-Level Compare Operation	518
Figure 12.5 Pin State When a Power-On Reset Is Issued from the Watchdog Timer	521

Section 13 Watchdog Timer (WDT)

Figure 13.1 Block Diagram of WDT.....	524
Figure 13.2 Writing to WTCNT and WTCSR	529
Figure 13.3 Operation in Watchdog Timer Mode (When WTCNT Count Clock Is Specified to P ϕ /32 by CKS2 to CKS0)	531

Section 14 Serial Communication Interface (SCI)

Figure 14.1 Block Diagram of SCI	534
Figure 14.2 Example of Data Format in Asynchronous Communication (8-Bit Data with Parity and Two Stop Bits).....	566
Figure 14.3 Sample Flowchart for SCI Initialization	569
Figure 14.4 Sample Flowchart for Transmitting Serial Data	570
Figure 14.5 Example of Transmission in Asynchronous Mode (8-Bit Data, Parity, One Stop Bit).....	572
Figure 14.6 Sample Flowchart for Receiving Serial Data (1)	573
Figure 14.6 Sample Flowchart for Receiving Serial Data (2)	574
Figure 14.7 Example of SCI Receive Operation (8-Bit Data, Parity, One Stop Bit).....	576
Figure 14.8 Data Format in Clock Synchronous Communication	576
Figure 14.9 Sample Flowchart for SCI Initialization	578
Figure 14.10 Sample Flowchart for Transmitting Serial Data	579
Figure 14.11 Example of SCI Transmit Operation.....	580
Figure 14.12 Sample Flowchart for Receiving Serial Data (1)	581
Figure 14.12 Sample Flowchart for Receiving Serial Data (2)	582
Figure 14.13 Example of SCI Receive Operation	583

Figure 14.14	Sample Flowchart for Transmitting/Receiving Serial Data	584
Figure 14.15	Example of Communication Using Multiprocessor Format (Transmission of Data H'AA to Receiving Station A).....	586
Figure 14.16	Sample Multiprocessor Serial Transmission Flowchart	587
Figure 14.17	Example of SCI Operation in Reception (Example with 8-Bit Data, Multiprocessor Bit, One Stop Bit)	588
Figure 14.18	Sample Multiprocessor Serial Reception Flowchart (1)	589
Figure 14.18	Sample Multiprocessor Serial Reception Flowchart (2)	590
Figure 14.19	SCKIO Bit, SCKDT Bit, and SCK Pin	592
Figure 14.20	SPBIO Bit, SPBDT Bit, and TXD Pin.....	593
Figure 14.21	Receive Data Sampling Timing in Asynchronous Mode.....	596
Figure 14.22	Example of Clock Synchronous Transfer Using DTC.....	597
Section 15 A/D Converter (ADC)		
Figure 15.1	Block Diagram of A/D Converter (for One Module).....	600
Figure 15.2	A/D Conversion Timing	618
Figure 15.3	External Trigger Input Timing.....	620
Figure 15.4	Example of 2-Channel Scanning	621
Figure 15.5	Definitions of A/D Conversion Accuracy.....	624
Figure 15.6	Definitions of A/D Conversion Accuracy.....	625
Figure 15.7	Example of Analog Input Circuit.....	627
Figure 15.8	Example of Analog Input Protection Circuit	628
Section 16 Compare Match Timer (CMT)		
Figure 16.1	Block Diagram of CMT.....	629
Figure 16.2	Counter Operation	634
Figure 16.3	Count Timing.....	634
Figure 16.4	Timing of CMF Setting.....	636
Figure 16.5	Conflict between Write and Compare-Match Processes of CMCNT	637
Figure 16.6	Conflict between Word-Write and Count-Up Processes of CMCNT	638
Figure 16.7	Conflict between Byte-Write and Count-Up Processes of CMCNT.....	639
Section 18 I/O Ports		
Figure 18.1	Port A (SH7146)	710
Figure 18.2	Port A (SH7149)	711
Figure 18.3	Port B (SH7146)	715
Figure 18.4	Port B (SH7149)	715
Figure 18.5	Port D.....	721
Figure 18.6	Port E (SH7146)	725
Figure 18.7	Port E (SH7149)	726

Figure 18.8	Port F	732
-------------	--------------	-----

Section 19 Flash Memory

Figure 19.1	Block Diagram of Flash Memory	737
Figure 19.2	Mode Transition of Flash Memory	738
Figure 19.3	Flash Memory Configuration.....	741
Figure 19.4	Block Division of User MAT.....	742
Figure 19.5	Overview of User Procedure Program.....	743
Figure 19.6	System Configuration in Boot Mode	772
Figure 19.7	Automatic Adjustment Operation of SCI Bit Rate.....	773
Figure 19.8	State Transitions in Boot Mode	775
Figure 19.9	Programming/Erasing Overview Flow	776
Figure 19.10	RAM Map after Download	777
Figure 19.11	Programming Procedure	778
Figure 19.12	Erasing Procedure	783
Figure 19.13	Procedure for Programming User MAT in User Boot Mode.....	786
Figure 19.14	Procedure for Erasing User MAT in User Boot Mode.....	788
Figure 19.15	Transitions to and from Error Protection State	792
Figure 19.16	Emulation of Flash Memory in RAM	793
Figure 19.17	Example of Overlapped RAM Operation	794
Figure 19.18	Programming of Tuned Data	795
Figure 19.19	Switching between User MAT and User Boot MAT.....	797
Figure 19.20	Timing of Contention between SCO Download Request and Interrupt Request.....	798
Figure 19.21	Flow of Processing by the Boot Program	803
Figure 19.22	Sequence of Bit-Rate Matching	804
Figure 19.23	Formats in the Communications Protocol.....	805
Figure 19.24	Sequence of New Bit Rate Selection	817
Figure 19.25	Sequence of Programming.....	821
Figure 19.26	Sequence of Erasure.....	825

Section 20 Masked ROM

Figure 20.1	Masked ROM Block Diagram	841
-------------	--------------------------------	-----

Section 21 RAM

Figure 21.1	On-chip RAM Addresses.....	843
-------------	----------------------------	-----

Section 24 Electrical Characteristics

Figure 24.1	EXTAL Clock Input Timing.....	911
Figure 24.2	CK Clock Output Timing.....	912

Figure 24.3	Power-On Oscillation Settling Timing	912
Figure 24.4	Oscillation Settling Timing on Return from Standby (Return by Reset)	912
Figure 24.5	Oscillation Settling Timing on Return from Standby (Return by NMI or IRQ)	913
Figure 24.6	Reset Input Timing	915
Figure 24.7	Interrupt Signal Input Timing	915
Figure 24.8	Interrupt Signal Output Timing	916
Figure 24.9	Bus Release Timing	916
Figure 24.10	Pin Driving Timing in Standby Mode	916
Figure 24.11	Basic Bus Timing for Normal Space (No Wait)	918
Figure 24.12	Basic Bus Timing for Normal Space (One Software Wait Cycle).....	919
Figure 24.13	Basic Bus Timing for Normal Space (One External Wait Cycle).....	920
Figure 24.14	Basic Bus Timing for Normal Space (One Software Wait Cycle, External Wait Cycle Valid (WM Bit = 0), No Idle Cycle)	921
Figure 24.15	CS Extended Bus Cycle for Normal Space (SW = 1 Cycle, HW = 1 Cycle, One External Wait Cycle).....	922
Figure 24.16	MTU2 Input/Output Timing	923
Figure 24.17	MTU2 Clock Input Timing	923
Figure 24.18	MTU2S Input/Output Timing	924
Figure 24.19	I/O Port Input/Output Timing	925
Figure 24.20	WDT Timing	926
Figure 24.21	Input Clock Timing	927
Figure 24.22	SCI Input/Output Timing.....	928
Figure 24.23	POE Input Timing.....	929
Figure 24.24	UBC Trigger Timing	930
Figure 24.25	External Trigger Input Timing.....	931
Figure 24.26	Output Load Circuit	932
Figure 24.27	Connection of VCL Capacitor	935

Appendix

Figure E.1	FP-80WV	947
Figure E.2	FP-100UV.....	948

Tables

Section 1 Overview

Table 1.1	Features	2
Table 1.2	Pin Functions.....	9

Section 2 CPU

Table 2.1	Initial Values of Registers	19
Table 2.2	Word Data Sign Extension	21
Table 2.3	Delayed Branch Instructions	22
Table 2.4	T Bit	22
Table 2.5	Access to Immediate Data.....	23
Table 2.6	Access to Absolute Address	23
Table 2.7	Access with Displacement.....	24
Table 2.8	Addressing Modes and Effective Addresses	24
Table 2.9	Instruction Formats	28
Table 2.10	Instruction Types.....	31
Table 2.11	Data Transfer Instructions.....	35
Table 2.12	Arithmetic Operation Instructions.....	37
Table 2.13	Logic Operation Instructions.....	39
Table 2.14	Shift Instructions	40
Table 2.15	Branch Instructions	41
Table 2.16	System Control Instructions	42

Section 3 MCU Operating Modes

Table 3.1	Selection of Operating Modes.....	47
Table 3.2	Pin Configuration	48

Section 4 Clock Pulse Generator (CPG)

Table 4.1	Operating Clock for Each Module	56
Table 4.2	Pin Configuration	57
Table 4.3	Clock Operating Mode	58
Table 4.4	Frequency Division Ratios Specifiable with FRQCR	59
Table 4.5	Register Configuration	63
Table 4.6	Damping Resistance Values (Reference Values)	68
Table 4.7	Crystal Resonator Characteristics	69

Section 5 Exception Handling

Table 5.1	Types of Exceptions and Priority	73
-----------	--	----

Table 5.2	Timing for Exception Detection and Start of Exception Handling	74
Table 5.3	Vector Numbers and Vector Table Address Offsets	75
Table 5.4	Calculating Exception Handling Vector Table Addresses	76
Table 5.5	Reset Status	77
Table 5.6	Bus Cycles and Address Errors	79
Table 5.7	Interrupt Sources	81
Table 5.8	Interrupt Priority.....	82
Table 5.9	Types of Exceptions Triggered by Instructions.....	83
Table 5.10	Delay Slot Instructions, Interrupt Disabled Instructions, and Exceptions.....	85
Table 5.11	Stack Status after Exception Handling Ends	86

Section 6 Interrupt Controller (INTC)

Table 6.1	Pin Configuration.....	93
Table 6.2	Register Configuration.....	94
Table 6.3	Interrupt Exception Handling Vectors and Priorities	106
Table 6.4	Interrupt Response Time	113

Section 7 User Break Controller (UBC)

Table 7.1	Pin Configuration.....	119
Table 7.2	Register Configuration.....	120
Table 7.3	Data Access Cycle Addresses and Operand Size Comparison Conditions	142

Section 8 Data Transfer Controller (DTC)

Table 8.1	Register Configuration.....	155
Table 8.2	Interrupt Sources, DTC Vector Addresses, and Corresponding DTCEs.....	168
Table 8.3	DTC Transfer Modes	170
Table 8.4	DTC Transfer Conditions (Chain Transfer Conditions Included).....	172
Table 8.5	Transfer Information Writeback Skip Condition and Writeback Skipped Registers.....	176
Table 8.6	Register Function in Normal Transfer Mode	176
Table 8.7	Register Function in Repeat Transfer Mode	178
Table 8.8	Register Function in Block Transfer Mode.....	179
Table 8.9	DTC Execution Status.....	185
Table 8.10	Number of Cycles Required for Each Execution State	186
Table 8.11	DTC Bus Release Timing	188

Section 9 Bus State Controller (BSC)

Table 9.1	Pin Configuration.....	199
Table 9.2	Address Map (Single-Chip Mode)	200
Table 9.3	Address Map (SH7149 in On-Chip ROM-Enabled Mode).....	201

Table 9.4	Address Map (SH7149 in On-Chip ROM-Disabled Mode)	202
Table 9.5	Register Configuration	203
Table 9.6	16-Bit External Device Access and Data Alignment	214
Table 9.7	8-Bit External Device Access and Data Alignment	215
Table 9.8	Minimum Number of Idle Cycles between CPU Access Cycles in Normal Space Interface.....	224
Table 9.9	Minimum Number of Idle Cycles between Access Cycles during DTC Transfer for the Normal Space Interface.....	225
Table 9.10	Number of Cycles for Access to On-Chip Peripheral I/O Registers	231
Table 9.11	Number of External Access Cycles.....	233

Section 10 Multi-Function Timer Pulse Unit 2 (MTU2)

Table 10.1	MTU2 Functions	238
Table 10.2	Pin Configuration	243
Table 10.3	Register Configuration	244
Table 10.4	CCLR0 to CCLR2 (Channels 0, 3, and 4).....	249
Table 10.5	CCLR0 to CCLR2 (Channels 1 and 2).....	249
Table 10.6	TPSC0 to TPSC2 (Channel 0).....	250
Table 10.7	TPSC0 to TPSC2 (Channel 1).....	250
Table 10.8	TPSC0 to TPSC2 (Channel 2).....	251
Table 10.9	TPSC0 to TPSC2 (Channels 3 and 4).....	251
Table 10.10	TPSC1 and TPSC0 (Channel 5)	252
Table 10.11	Setting of Operation Mode by Bits MD0 to MD3	254
Table 10.12	TIORH_0 (Channel 0).....	257
Table 10.13	TIORL_0 (Channel 0)	258
Table 10.14	TIOR_1 (Channel 1).....	259
Table 10.15	TIOR_2 (Channel 2).....	260
Table 10.16	TIORH_3 (Channel 3).....	261
Table 10.17	TIORL_3 (Channel 3)	262
Table 10.18	TIORH_4 (Channel 4).....	263
Table 10.19	TIORL_4 (Channel 4)	264
Table 10.20	TIORH_0 (Channel 0).....	265
Table 10.21	TIORL_0 (Channel 0)	266
Table 10.22	TIOR_1 (Channel 1).....	267
Table 10.23	TIOR_2 (Channel 2).....	268
Table 10.24	TIORH_3 (Channel 3).....	269
Table 10.25	TIORL_3 (Channel 3)	270
Table 10.26	TIORH_4 (Channel 4).....	271
Table 10.27	TIORL_4 (Channel 4)	272
Table 10.28	TIORU_5, TIORV_5, and TIORW_5 (Channel 5).....	273

Table 10.29	Setting of Transfer Timing by BF1 and BF0 Bits	295
Table 10.30	Output Level Select Function.....	308
Table 10.31	Output Level Select Function.....	309
Table 10.32	Setting of Bits BF1 and BF0	311
Table 10.33	TIOC4D Output Level Select Function.....	311
Table 10.34	TIOC4B Output Level Select Function.....	312
Table 10.35	TIOC4C Output Level Select Function.....	312
Table 10.36	TIOC4A Output Level Select Function.....	312
Table 10.37	TIOC3D Output Level Select Function.....	312
Table 10.38	TIOC4B Output Level Select Function.....	313
Table 10.39	Output level Select Function	316
Table 10.40	Setting of Interrupt Skipping Count by Bits 3ACOR2 to 3ACOR0.....	319
Table 10.41	Setting of Interrupt Skipping Count by Bits 4VCOR2 to 4VCOR0.....	319
Table 10.42	Setting of Bits BTE1 and BTE0.....	322
Table 10.43	Register Combinations in Buffer Operation.....	335
Table 10.44	Cascaded Combinations	339
Table 10.45	TICCR Setting and Input Capture Input Pins.....	340
Table 10.46	PWM Output Registers and Output Pins.....	345
Table 10.47	Phase Counting Mode Clock Input Pins.....	349
Table 10.48	Up/Down-Count Conditions in Phase Counting Mode 1	350
Table 10.49	Up/Down-Count Conditions in Phase Counting Mode 2	351
Table 10.50	Up/Down-Count Conditions in Phase Counting Mode 3	352
Table 10.51	Up/Down-Count Conditions in Phase Counting Mode 4	353
Table 10.52	Output Pins for Reset-Synchronized PWM Mode	356
Table 10.53	Register Settings for Reset-Synchronized PWM Mode	356
Table 10.54	Output Pins for Complementary PWM Mode.....	359
Table 10.55	Register Settings for Complementary PWM Mode.....	360
Table 10.56	Registers and Counters Requiring Initialization.....	366
Table 10.57	MTU2 Interrupts	419
Table 10.58	Interrupt Sources and A/D Converter Start Request Signals.....	422
Table 10.59	Mode Transition Combinations.....	454

Section 11 Multi-Function Timer Pulse Unit 2S (MTU2S)

Table 11.1	MTU2S Functions.....	486
Table 11.2	Pin Configuration.....	489
Table 11.3	Register Configuration.....	490

Section 12 Port Output Enable (POE)

Table 12.1	Pin Configuration.....	495
Table 12.2	Pin Combinations.....	496

Table 12.3	Register Configuration	497
Table 12.4	Target Pins and Conditions for High-Impedance Control.....	516
Table 12.5	Interrupt Sources and Conditions	520

Section 13 Watchdog Timer (WDT)

Table 13.1	WDT Pin Configuration	525
Table 13.2	Register Configuration	526
Table 13.3	Interrupt Source.....	532

Section 14 Serial Communication Interface (SCI)

Table 14.1	Pin Configuration	535
Table 14.2	Register Configuration	536
Table 14.3	SCSMR Settings.....	554
Table 14.4	Bit Rates and SCBRR Settings in Asynchronous Mode (1).....	555
Table 14.5	Bit Rates and SCBRR Settings in Asynchronous Mode (2).....	556
Table 14.6	Bit Rates and SCBRR Settings in Asynchronous Mode (3).....	557
Table 14.7	Bit Rates and SCBRR Settings in Clock Synchronous Mode (1).....	558
Table 14.8	Bit Rates and SCBRR Settings in Clock Synchronous Mode (2).....	559
Table 14.9	Bit Rates and SCBRR Settings in Clock Synchronous Mode (3).....	560
Table 14.10	Maximum Bit Rates for Various Frequencies with Baud Rate Generator (Asynchronous Mode).....	561
Table 14.11	Maximum Bit Rates with External Clock Input (Asynchronous Mode)	562
Table 14.12	Maximum Bit Rates with External Clock Input (Clock Synchronous Mode).....	563
Table 14.13	SCSMR Settings and SCI Communication Formats	565
Table 14.14	SCSMR and SCSCR Settings and SCI Clock Source Selection	565
Table 14.15	Serial Transfer Formats (Asynchronous Mode).....	567
Table 14.16	Receive Errors and Error Conditions	575
Table 14.17	SCI Interrupt Sources	591
Table 14.18	SCSSR Status Flag Values and Transfer of Received Data	594

Section 15 A/D Converter (ADC)

Table 15.1	Pin Configuration	601
Table 15.2	Register Configuration	602
Table 15.3	Channel Select List.....	608
Table 15.4	A/D Conversion Time (Single Mode)	619
Table 15.5	A/D Conversion Time (Scan Mode).....	619
Table 15.6	A/D Converter Interrupt Source	622
Table 15.7	Analog Pin Specifications	628

Section 16 Compare Match Timer (CMT)	
Table 16.1	Register Configuration..... 630
Table 16.2	Interrupt Source..... 635
Section 17 Pin Function Controller (PFC)	
Table 17.1	SH7146 Multiplexed Pins (Port A) 641
Table 17.2	SH7149 Multiplexed Pins (Port A) 642
Table 17.3	SH7146 Multiplexed Pins (Port B) 642
Table 17.4	SH7149 Multiplexed Pins (Port B) 643
Table 17.5	SH7149 Multiplexed Pins (Port D) 643
Table 17.6	SH7146 Multiplexed Pins (Port E)..... 644
Table 17.7	SH7149 Multiplexed Pins (Port E)..... 645
Table 17.8	Multiplexed Pins (Port F)..... 646
Table 17.9	SH7146 Pin Functions in Each Operating Mode 647
Table 17.10	SH7149 Pin Functions in Each Operating Mode (1)..... 650
Table 17.11	SH7149 Pin Functions in Each Operating Mode (2)..... 654
Table 17.12	Register Configuration 658
Table 17.13	Transmit Forms of Input Functions Allocated to Multiple Pins..... 707
Section 18 I/O Ports	
Table 18.1	Register Configuration 712
Table 18.2	Port A Data Register L (PADRL) Read/Write Operations..... 713
Table 18.3	Register Configuration 716
Table 18.4	Port B Data Register (PBDR) Read/Write Operations 718
Table 18.5	Register Configuration 722
Table 18.6	Port D Data Register L (PDDRL) Read/Write Operations..... 723
Table 18.7	Register Configuration 727
Table 18.8	Port E Data Register (PEDR) Read/Write Operations 730
Table 18.9	Register Configuration 733
Table 18.10	Port F Data Register L (PFDRL) Read/Write Operations..... 734
Section 19 Flash Memory	
Table 19.1 (1)	Relationship between FWE and MD Pins and Operating Modes (SH7146)..... 739
Table 19.1 (2)	Relationship between FWE and MD Pins and Operating Modes (SH7149)..... 739
Table 19.2	Comparison of Programming Modes 740
Table 19.3	Pin Configuration..... 745
Table 19.4 (1)	Register Configuration 746
Table 19.4 (2)	Parameter Configuration..... 746
Table 19.5	Register/Parameter and Target Mode..... 747

Table 19.6	Usable Parameters and Target Modes	756
Table 19.7	Overlapping of RAM Area and User MAT Area	771
Table 19.8	Peripheral Clock (P ϕ) Frequency that Can Automatically Adjust Bit Rate of This LSI.....	773
Table 19.9	Hardware Protection.....	790
Table 19.10	Software Protection	791
Table 19.11	Initiation Intervals of User Branch Processing.....	800
Table 19.12	Initial User Branch Processing Time.....	800
Table 19.13	Inquiry and Selection Commands	806
Table 19.14	Programming and Erasure Commands	820
Table 19.15	Status Codes	831
Table 19.16	Error Codes	832
Table 19.17	Executable MAT	833
Table 19.18 (1)	Usable Area for Programming in User Program Mode	834
Table 19.18 (2)	Usable Area for Erasure in User Program Mode	835
Table 19.18 (3)	Usable Area for Programming in User Boot Mode	836
Table 19.18 (3)	Usable Area for Programming in User Boot Mode (cont).....	837
Table 19.18 (4)	Usable Area for Erasure in User Boot Mode	838
Table 19.18 (4)	Usable Area for Erasure in User Boot Mode (cont).....	839

Section 22 Power-Down Modes

Table 22.1	States of Power-Down Modes.....	846
Table 22.2	Pin Configuration	847
Table 22.3	Register Configuration	848

Section 24 Electrical Characteristics

Table 24.1	Absolute Maximum Ratings.....	905
Table 24.2	DC Characteristics.....	906
Table 24.3	Permitted Output Current Values	909
Table 24.4	Maximum Operating Frequency	910
Table 24.5	Clock Timing	911
Table 24.6	Control Signal Timing.....	914
Table 24.7	Bus Timing.....	917
Table 24.8	Multi Function Timer Pulse Unit 2 (MTU2) Timing	923
Table 24.9	Multi Function Timer Pulse Unit 2S (MTU2S) Timing.....	924
Table 24.10	I/O Port Timing	925
Table 24.11	Watchdog Timer (WDT) Timing	926
Table 24.12	Serial Communication Interface (SCI) Timing	927
Table 24.13	Port Output Enable (POE) Timing	929
Table 24.14	UBC Trigger Timing.....	930

Table 24.15	A/D Converter Timing	931
Table 24.16	A/D Converter Characteristics	933
Table 24.17	Flash Memory Characteristics.....	934

Appendix

Table A.1	Pin States (SH7146)	937
Table A.2	Pin States (SH7149)	940
Table B.1	Processing of Unused Pins	943
Table C.1	Pin States of Bus Related Signals (1).....	944
Table C.1	Pin States of Bus Related Signals (2).....	945
Table D.1	Product Code Lineup.....	946

Section 1 Overview

1.1 Features of SH7146 and SH7149

This LSI is a single-chip RISC (Reduced Instruction Set Computer) microcomputer that integrates a Renesas original RISC CPU core with peripheral functions required for system configuration.

The CPU in this LSI has a RISC-type instruction set. Most instructions can be executed in one state (one system clock cycle), which greatly improves instruction execution speed. In addition, the 32-bit internal-bus architecture enhances data processing power. With this CPU, it has become possible to assemble low-cost, high-performance, and high-functioning systems, even for applications that were previously impossible with microcomputers, such as real-time control, which demands high speeds.

In addition, this LSI includes on-chip peripheral functions necessary for system configuration, such as large-capacity ROM and RAM, a data transfer controller (DTC), timers, a serial communication interface (SCI), an A/D converter, an interrupt controller (INTC), and I/O ports.

This LSI also provides an external memory access support function to enable direct connection to various memory devices or peripheral LSIs.

These on-chip functions significantly reduce costs of designing and manufacturing application systems.

There are two versions of on-chip ROM: F-ZTAT™ (Flexible Zero Turn Around Time)* that includes flash memory, and masked ROM. The flash memory can be programmed with a programmer that supports programming of this LSI, and can also be programmed and erased by software. This enables LSI chip to be re-programmed at a user-site while mounted on a board.

The features of this LSI are listed in table 1.1.

Note: * F-ZTAT™ is a trademark of Renesas Electronics Corp.

Table 1.1 Features

Items	Specification
CPU	<ul style="list-style-type: none"> • Central processing unit with an internal 32-bit RISC (Reduced Instruction Set Computer) architecture • Instruction length: 16-bit fixed length for improved code efficiency • Load-store architecture (basic operations are executed between registers) • Sixteen 32-bit general registers • Five-stage pipeline • On-chip multiplier: Multiplication operations (32 bits × 32 bits → 64 bits) executed in two to five cycles • C language-oriented 62 basic instructions <p>Note: Some specifications on slot illegal instruction exception handling in this LSI differ from those of the conventional SH-2. For details, see section 5.8.4, Notes on Slot Illegal Instruction Exception Handling.</p>
Operating modes	<ul style="list-style-type: none"> • Operating modes <ul style="list-style-type: none"> — Single chip mode — Extended ROM enabled mode (only in SH7149) — Extended ROM disabled mode (only in SH7149) • Operating states <ul style="list-style-type: none"> — Program execution state — Exception handling state — Bus release state (only in SH7149) • Power-down modes <ul style="list-style-type: none"> — Sleep mode — Software standby mode — Deep software standby mode — Module standby mode
User break controller (UBC)	<ul style="list-style-type: none"> • Addresses, data values, type of access, and data size can all be set as break conditions • Supports a sequential break function • Two break channels • In the masked ROM version, only the L bus instruction fetch address break (two channels) can be set

Items	Specification
On-chip ROM	<ul style="list-style-type: none"> • 256 kbytes
On-chip RAM	<ul style="list-style-type: none"> • 8 kbytes
Bus state controller (BSC)	<ul style="list-style-type: none"> • Address space: A maximum 64 Mbytes for each of two areas (CS0 and CS1) (only in SH7149) • 8-bit external bus (only in SH7149) • 16-bit external bus (only in SH7149) • The following features settable for each area independently <ul style="list-style-type: none"> — Bus size (8 or 16 bits) — Number of access wait cycles — Idle wait cycle insertion — Supports SRAM • Outputs a chip select signal according to the target area
Data transfer controller (DTC) (only in F-ZTAT version)	<ul style="list-style-type: none"> • Data transfer activated by an on-chip peripheral module interrupt can be done independently of the CPU transfer. • Transfer mode selectable for each interrupt source (transfer mode is specified in memory) • Multiple data transfer enabled for one activation source • Various transfer modes Normal mode, repeat mode, or block transfer mode can be selected. • Data transfer size can be specified as byte, word, or longword • The interrupt that activated the DTC can be issued to the CPU. A CPU interrupt can be requested after one data transfer completion. • A CPU interrupt can be requested after all specified data transfer completion.
Interrupt controller (INTC)	<ul style="list-style-type: none"> • Five external interrupt pins (NMI and IRQ3 to IRQ0) • On-chip peripheral interrupts: Priority level set for each module • Vector addresses: A vector address for each interrupt source
User debugging interface (H-UDI) (only in F-ZTAT version)	<ul style="list-style-type: none"> • E10A emulator support
Advanced user debugger (AUD) (only in F-ZTAT version supporting full functions of E10A)	<ul style="list-style-type: none"> • E10A emulator support

Items	Specification
Clock pulse generator (CPG)	<ul style="list-style-type: none"> • Clock mode: Input clock can be selected from external input or crystal resonator • Five types of clocks generated: <ul style="list-style-type: none"> — CPU clock: Maximum 80 MHz — Bus clock: Maximum 40 MHz — Peripheral clock: Maximum 40 MHz — MTU2 clock: Maximum 40 MHz — MTU2S clock: Maximum 80 MHz
Watchdog timer (WDT)	<ul style="list-style-type: none"> • On-chip one-channel watchdog timer • Interrupt generation is supported.
Multi-function timer pulse unit 2 (MTU2)	<ul style="list-style-type: none"> • Maximum 16 lines of pulse input/output and three lines of pulse input based on six channels of 16-bit timers • 21 output compare and input capture registers • A total of 21 independent comparators • Selection of eight counter input clocks • Input capture function • Pulse output modes <ul style="list-style-type: none"> Toggle, PWM, complementary PWM, and reset-synchronized PWM modes • Synchronization of multiple counters • Complementary PWM output mode <ul style="list-style-type: none"> — Non-overlapping waveforms output for 6-phase inverter control — Automatic dead time setting — 0% to 100% PWM duty cycle specifiable — Output suppression — A/D conversion delaying function — Dead time compensation — Interrupt skipping at crest or trough • Reset-synchronized PWM mode <ul style="list-style-type: none"> Three-phase PWM waveforms in positive and negative phases can be output with a required duty cycle • Phase counting mode <ul style="list-style-type: none"> Two-phase encoder pulse counting available

Items	Specification
Multi-function timer pulse unit 2S (MTU2S)	<ul style="list-style-type: none"> • Subset of MTU2, including channels 3 to 5 • Operating at 80 MHz max.
Port output enable (POE)	<ul style="list-style-type: none"> • High-impedance control of waveform output pins in MTU2 and MTU2S
Compare match timer (CMT)	<ul style="list-style-type: none"> • 16-bit counters • Compare match interrupts can be generated • Two channels
Serial communication interface (SCI)	<ul style="list-style-type: none"> • Clock synchronous or asynchronous mode • Three channels
A/D converter (ADC)	<ul style="list-style-type: none"> • 10 bits × 12 channels • Conversion request by external triggers, MTU2, or MTU2S • Three sample-and-hold function units (three channels can be sampled simultaneously)
I/O ports	<ul style="list-style-type: none"> • 45 general input/output pins and 12 general input pins (SH7146) • 63 general input/output pins and 12 general input pins (SH7149) • Input or output can be selected for each bit
Packages	<ul style="list-style-type: none"> • LQFP1414-80 (0.65 pitch) (SH7146) • LQFP1414-100 (0.5 pitch) (SH7149)
Power supply voltage	<ul style="list-style-type: none"> • Vcc: 4.0 to 5.5 V • AVcc: 4.0 to 5.5 V

1.2 Block Diagram

The block diagram of this LSI is shown in figure 1.1.

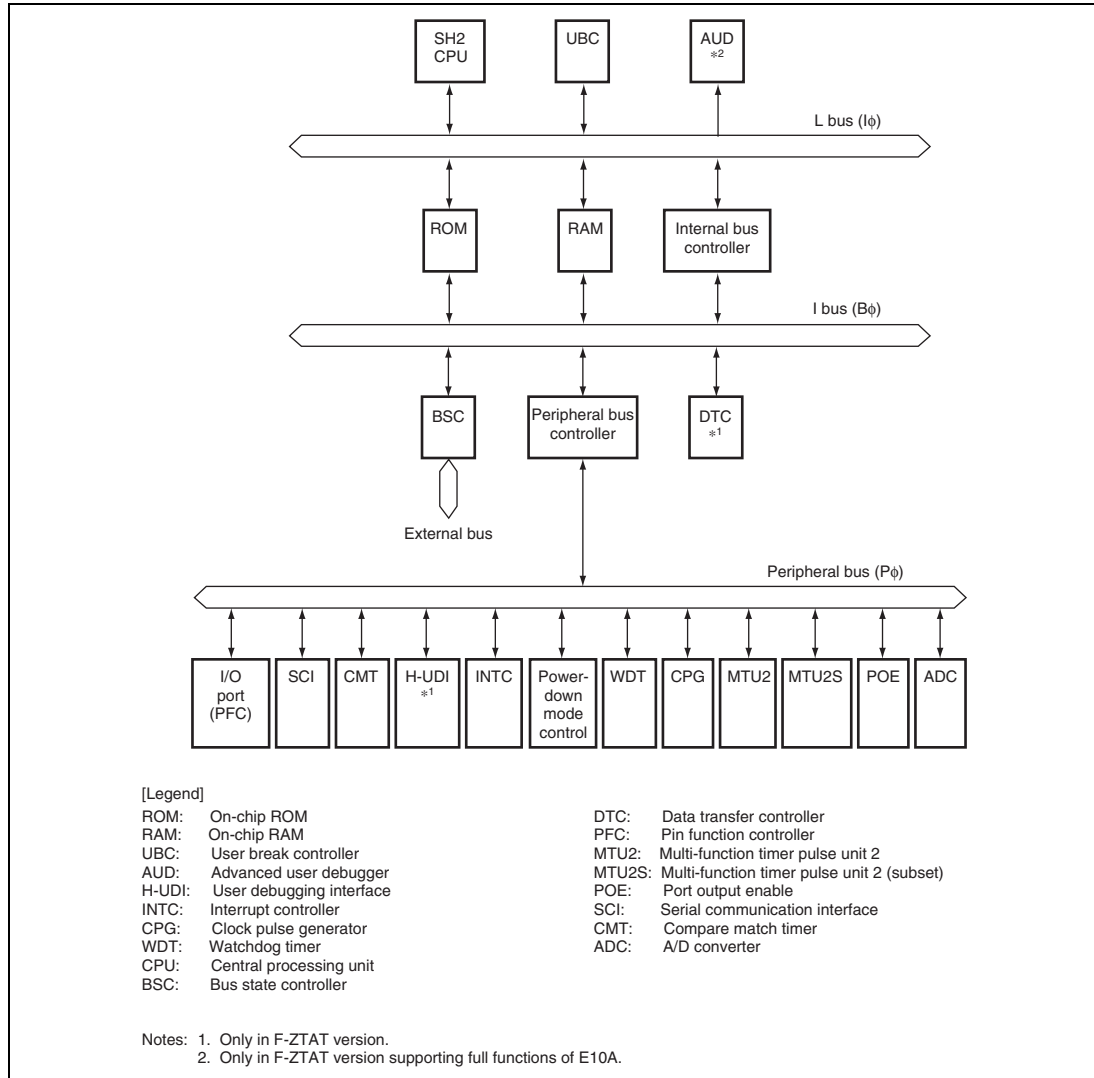

Figure 1.1 Block Diagram

1.3 Pin Assignments

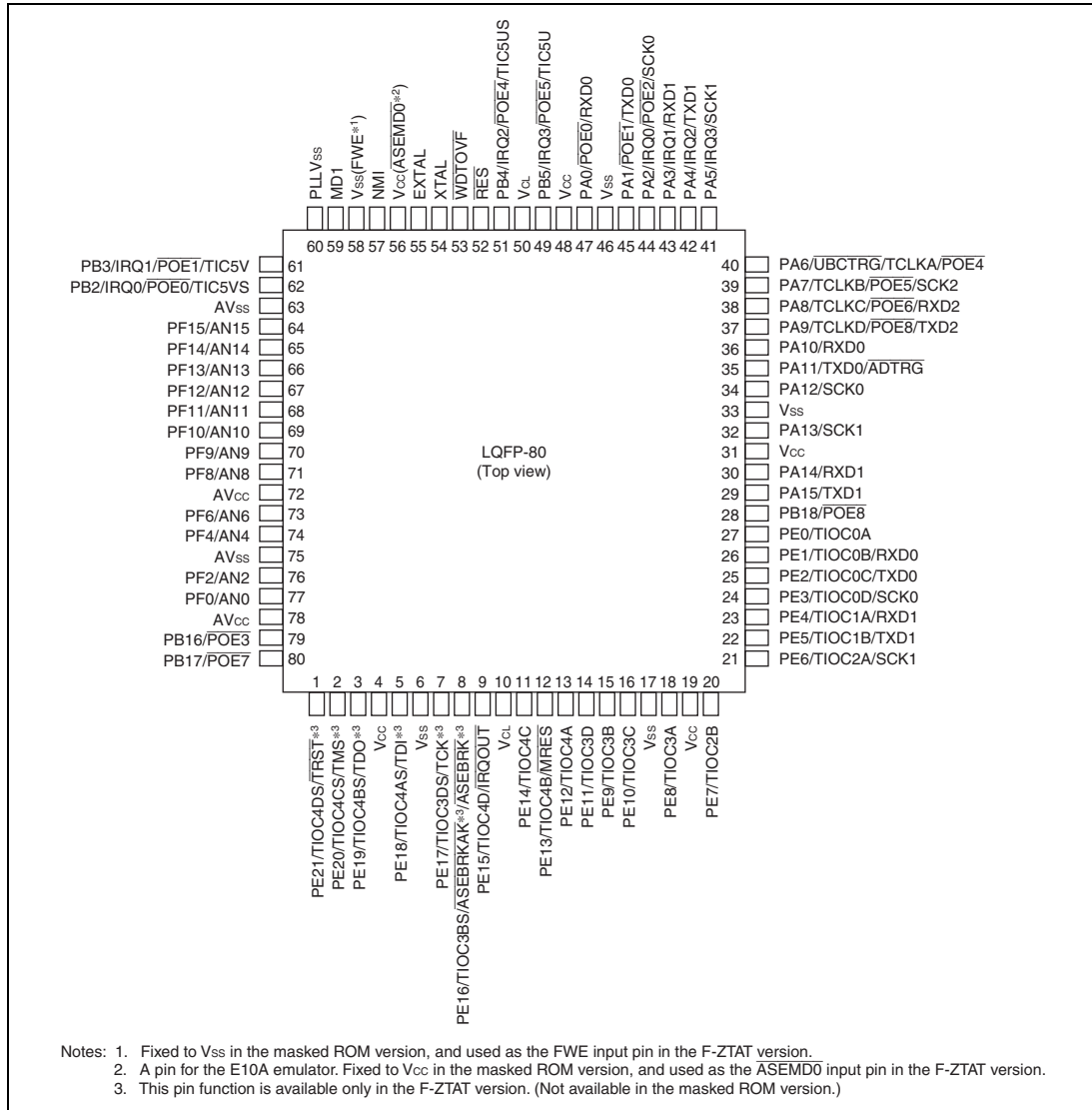

Figure 1.2 Pin Assignments of SH7146

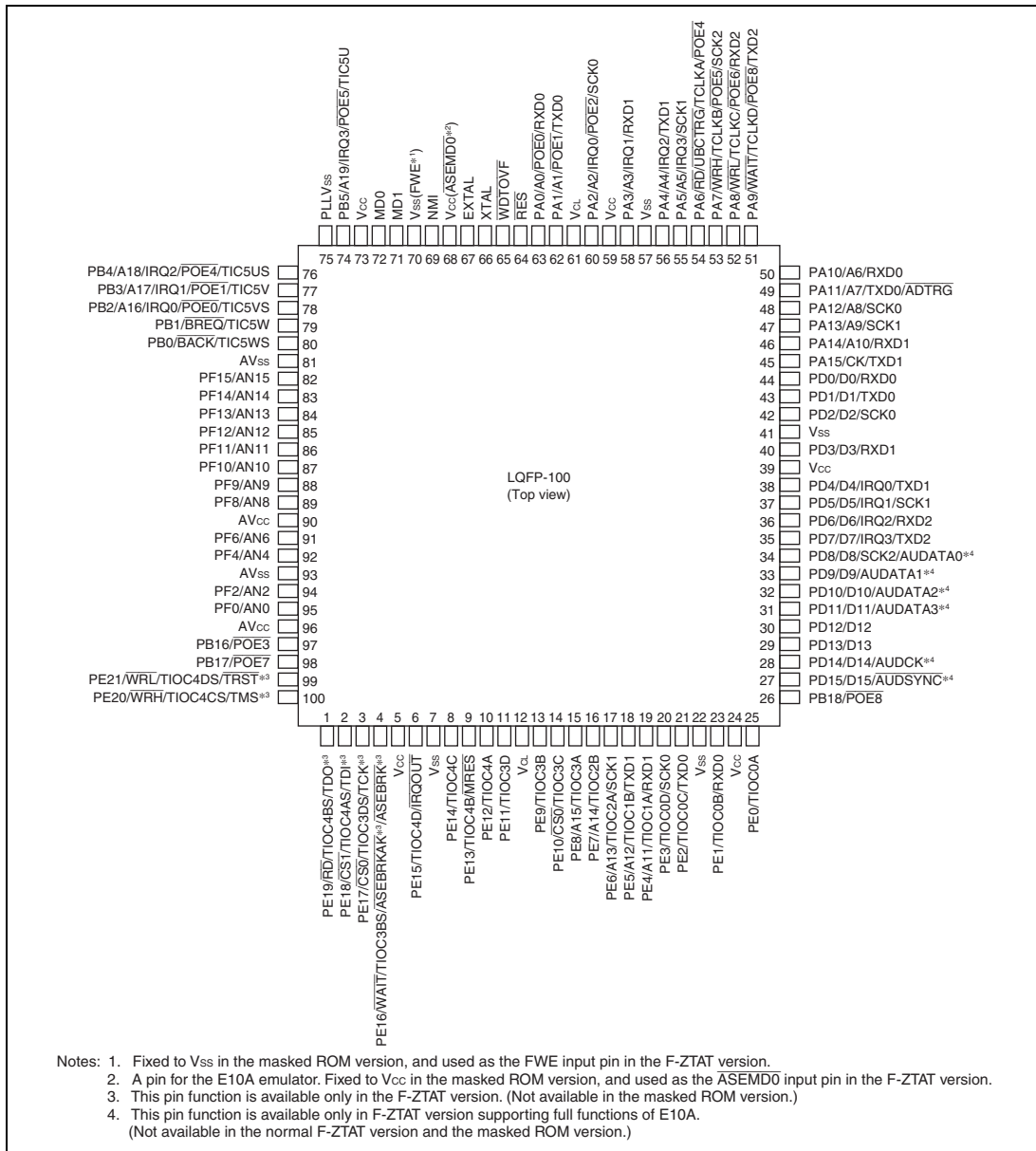

Figure 1.3 Pin Assignments of SH7149 (LQFP Version)

1.4 Pin Functions

Table 1.2 summarizes the pin functions.

Table 1.2 Pin Functions

Classification	Symbol	I/O	Name	Function
Power supply	Vcc	I	Power supply	Power supply pins. Connect all Vcc pins to the system. There will be no operation if any pins are open.
	Vss	I	Ground	Ground pin. Connect all Vss pins to the system power supply (0V). There will be no operation if any pins are open.
	VCL	O	Power supply for internal power-down	External capacitance pins for internal power-down power supply. Connect these pins to Vss via a 0.47 μ F capacitor (placed close to the pins).
Clock	PLLVss	I	PLL ground	Ground pin for the on-chip PLL oscillator
	EXTAL	I	External clock	Connected to a crystal resonator. An external clock signal may also be input to the EXTAL pin.
	XTAL	O	Crystal	Connected to a crystal resonator.
	CK	O	System clock	Supplies the system clock to external devices. This pin is not available in the SH7146.
Operating mode control	MD1, MD0	I	Mode set	Sets the operating mode. Do not change values on these pins during operation. Only MD1 is available in the SH7146.
	FWE	I	Flash memory write enable	Pin for flash memory. Flash memory can be protected against programming or erasure through this pin.

Classification	Symbol	I/O	Name	Function
System control	$\overline{\text{RES}}$	I	Power-on reset	When low, this LSI enters the power-on reset state.
	$\overline{\text{MRES}}$	I	Manual reset	When low, this LSI enters the manual reset state.
	$\overline{\text{WDTOVF}}$	O	Watchdog timer overflow	Output signal for the watchdog timer overflow. If this pin needs to be pulled down, use the resistor larger than 1 M Ω to pull this pin down.
	$\overline{\text{BREQ}}$	I	Bus-mastership request	Low when an external device requests the release of the bus mastership. This pin is not available in the SH7146.
	$\overline{\text{BACK}}$	O	Bus-mastership request acknowledge	Indicates that the bus mastership has been released to an external device. Reception of the $\overline{\text{BACK}}$ signal informs the device which has output the $\overline{\text{BREQ}}$ signal that it has acquired the bus. This pin is not available in the SH7146.
Interrupts	NMI	I	Non-maskable interrupt	Non-maskable interrupt request pin. Fix to high or low level when not in use.
	IRQ3 to IRQ0	I	Interrupt requests 3 to 0	Maskable interrupt request pin. Selectable as level input or edge input. The rising edge, falling edge, and both edges are selectable as edges.
	$\overline{\text{IRQOUT}}$	O	Interrupt request output	Shows that an interrupt cause has occurred. The interrupt cause can be recognized even in the bus release state.
Address bus	A19 to A0	O	Address bus	Outputs addresses. No address bus pins are available in the SH7146.
Data bus	D15 to D0	I/O	Data bus	16-bit bidirectional bus. No data bus pins are available in the SH7146.

Classification	Symbol	I/O	Name	Function
Bus control	$\overline{CS1}$, $\overline{CS0}$	O	Chip select 1 and 0	Chip-select signal for external memory or devices. No chip select pins are available in the SH7146.
	\overline{RD}	O	Read	Indicates reading of data from external devices. This pin is not available in the SH7146.
	\overline{WRH}	O	Write to upper byte	Indicates a write access to bits 15 to 8 of the external data. This pin is not available in the SH7146.
	\overline{WRL}	O	Write to lower byte	Indicates a write access to bits 7 to 0 of the external data. This pin is not available in the SH7146.
	\overline{WAIT}	I	Wait	Input signal for inserting a wait cycle into the bus cycles during access to the external space. This pin is not available in the SH7146.
Multi function timer-pulse unit 2 (MTU2)	TCLKA, TCLKB, TCLKC, TCLKD	I	MTU2 timer clock input	External clock input pins for the timer.
	TIOC0A, TIOC0B, TIOC0C, TIOC0D	I/O	MTU2 input capture/output compare (channel 0)	The TGRA_0 to TGRD_0 input capture input/output compare output/PWM output pins.
	TIOC1A, TIOC1B	I/O	MTU2 input capture/output compare (channel 1)	The TGRA_1 to TGRB_1 input capture input/output compare output/PWM output pins.
	TIOC2A, TIOC2B	I/O	MTU2 input capture/output compare (channel 2)	The TGRA_2 to TGRB_2 input capture input/output compare output/PWM output pins.

Classification	Symbol	I/O	Name	Function
Multi function timer-pulse unit 2 (MTU2)	TIOC3A, TIOC3B, TIOC3C, TIOC3D	I/O	MTU2 input capture/output compare (channel 3)	The TGRA_3 to TGRD_3 input capture input/output compare output/PWM output pins.
	TIOC4A, TIOC4B, TIOC4C, TIOC4D	I/O	MTU2 input capture/output compare (channel 4)	The TGRA_4 to TGRD_4 input capture input/output compare output/PWM output pins.
	TIC5U, TIC5V, TIC5W	I	MTU2 input capture (channel 5)	The TGRU_5, TGRV_5, and TGRW_5 input capture input pins. Only TIC5U and TIC5V are available in the SH7146.
Multi function timer-pulse unit 2S (MTU2S)	TIOC3BS, TIOC3DS	I/O	MTU2S input capture/output compare (channel 3)	The TGRB_3S and TGRD_3S input capture input/output compare output/PWM output pins.
	TIOC4AS, TIOC4BS, TIOC4CS, TIOC4DS	I/O	MTU2S input capture/output compare (channel 4)	The TGRA_4S to TGRD_4S input capture input/output compare output/PWM output pins.
	TIC5US, TIC5VS, TIC5WS	I	MTU2S input capture (channel 5)	The TGRU_5S, TGRV_5S, and TGRW_5S input capture input pins. Only TIC5US and TIC5VS are available in the SH7146.
Port output enable (POE)	$\overline{\text{POE8}}$ to $\overline{\text{POE0}}$	I	Port output enable	Request signal input to place the MTU2 and MTU2S waveform output pins in high impedance state. While POE functions are selected in the PFC, pins PB16/ $\overline{\text{POE3}}$, PB17/ $\overline{\text{POE7}}$, and PB18/ $\overline{\text{POE8}}$ are pulled up inside this LSI if no signals are input to them.
Serial communication interface (SCI)	TXD2 to TXD0	O	Transmit data	Transmit data output pins
	RXD2 to RXD0	I	Receive data	Receive data input pins
	SCK2 to SCK0	I/O	Serial clock	Clock input/output pins

Classification	Symbol	I/O	Name	Function
A/D converter (ADC)	AN15 to AN8, AN6, AN4, AN2, AN0	I	Analog input pins	Analog input pins.
	\overline{ADTRG}	I	A/D conversion trigger input	External trigger input pin for starting A/D conversion.
	AVcc	I	Analog power supply	Power supply pin for the A/D converter. Connect all AVcc pins to the system power supply (Vcc) when the A/D converter is not used. The A/D converter does not work if any pin is open.
	AVss	I	Analog ground	Ground pin for the A/D converter. Connect it to the system ground (0 V). Connect all AVss pins to the system ground (0 V) correctly. The A/D converter does not work if any pin is open.
I/O ports	PA15 to PA0	I/O	General port	16-bit general input/output port pins.
	PB18 to PB16, PB5 to PB0	I/O	General port	9-bit general input/output port pins. PB18 to PB16 and PB5 to PB2 are available in the SH7146.
	PD15 to PD0	I/O	General port	16-bit general input/output port pins. These port pins are not available in the SH7146.
	PE21 to PE0	I/O	General port	22-bit general input/output port pins.
	PF15 to PF8, PF6, PF4, PF2, PF0	I	General port	12-bit general input port pins.
User break controller (UBC)	$\overline{UBCTR\overline{G}}$	O	User break trigger output	Trigger output pin for UBC condition match.

Classification	Symbol	I/O	Name	Function
User debugging interface (H-UDI) (only in F-ZTAT version)	TCK	I	Test clock	Test-clock input pin.
	TMS	I	Test mode select	Inputs the test-mode select signal.
	TDI	I	Test data input	Serial input pin for instructions and data.
	TDO	O	Test data output	Serial output pin for instructions and data.
	$\overline{\text{TRST}}$	I	Test reset	Initialization-signal input pin.
Advanced user debugger (AUD) (only in SH7149 F-ZTAT version supporting full functions of E10A)	AUDATA3 to AUDATA0	O	AUD data	Branch destination address output pins.
	AUDCK	O	AUD clock	Sync-clock output pin.
	$\overline{\text{AUDSYNC}}$	O	AUD sync signal	Data start-position acknowledge-signal output pin.
E10A interface (only in F-ZTAT version)	$\overline{\text{ASEMD0}}$	I	ASE mode	Sets the ASE mode. When a low level is input, this LSI enters ASE mode. When a high level is input, this LSI enters the normal mode. The emulator functions are available in ASE mode. When no signal is input, this pin is pulled up inside this LSI.
	$\overline{\text{ASEBRK}}$	I	Break request	E10A emulator break input pin.
	$\overline{\text{ASEBRKAK}}$	O	Break mode acknowledge	Indicates that the E10A emulator has entered its break mode.

Note: The $\overline{\text{WDTOVF}}$ pin should not be pulled down. When absolutely necessary, pull it down through a resistor of 1 M Ω or larger.

Section 2 CPU

2.1 Features

- General registers: 32-bit register × 16
- Basic instructions: 62
- Addressing modes: 11
 - Register direct (Rn)
 - Register indirect (@Rn)
 - Post-increment register indirect (@Rn+)
 - Pre-decrement register indirect (@-Rn)
 - Register indirect with displacement (@disp:4, Rn)
 - Index register indirect (@R0, Rn)
 - GBR indirect with displacement (@disp:8, GBR)
 - Index GBR indirect (@R0, GBR)
 - PC relative with displacement (@disp:8, PC)
 - PC relative (disp:8/disp:12/Rn)
 - Immediate (#imm:8)

2.2 Register Configuration

There are three types of registers: general registers (32-bit × 16), control registers (32-bit × 3), and system registers (32-bit × 4).

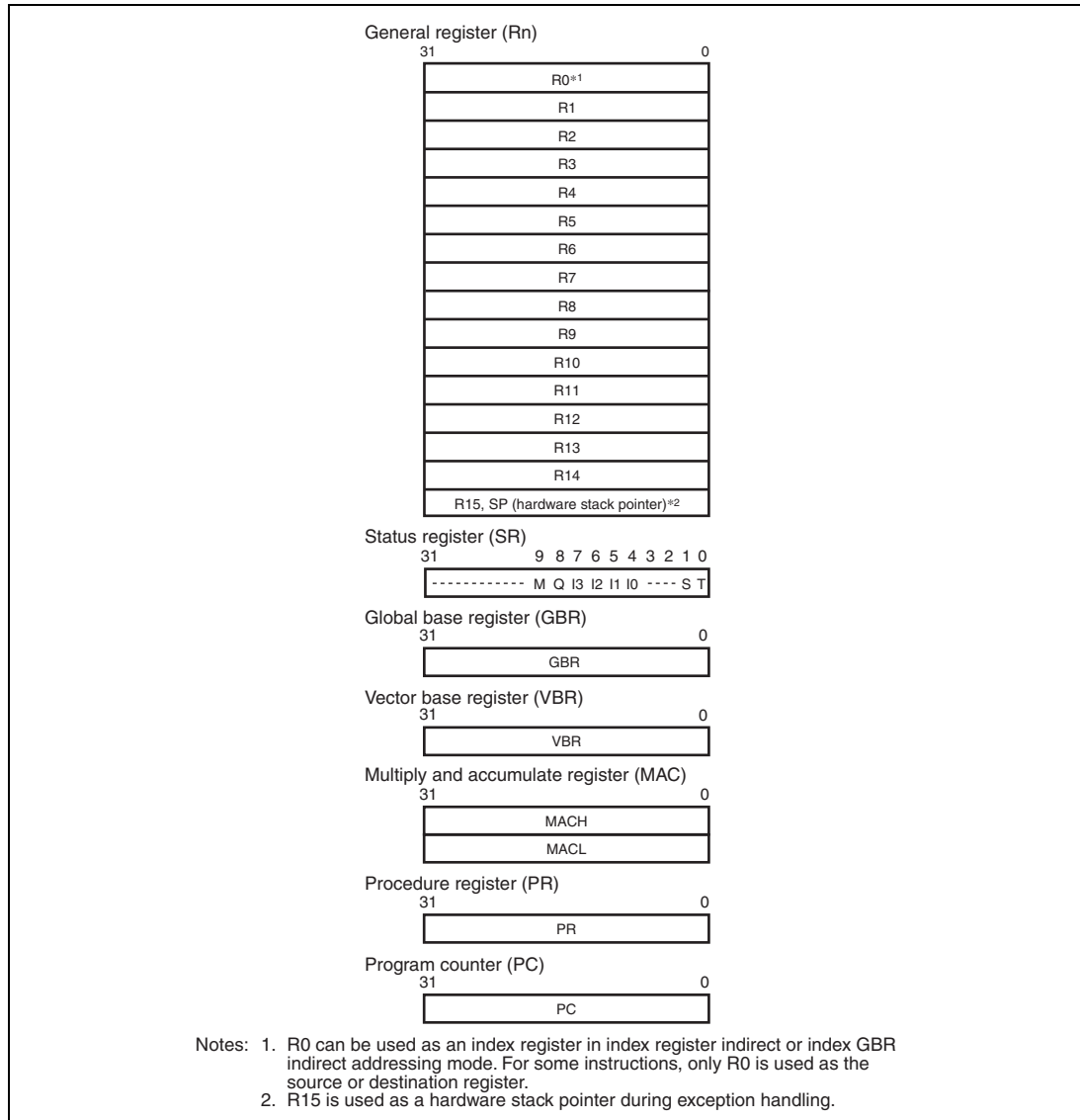

Figure 2.1 CPU Internal Register Configuration

2.2.1 General Registers (Rn)

There are sixteen 32-bit general registers (Rn), designated R0 to R15. The general registers are used for data processing and address calculation. R0 is also used as an index register. With a number of instructions, R0 is the only register that can be used. R15 is used as a hardware stack pointer (SP). In exception handling, R15 is used for accessing the stack to save or restore the status register (SR) and program counter (PC) values.

2.2.2 Control Registers

There are three 32-bit control registers, designated status register (SR), global base register (GBR), and vector base register (VBR). SR indicates a processing state. GBR is used as a base address in GBR indirect addressing mode for data transfer of on-chip peripheral module registers. VBR is used as a base address of the exception handling (including interrupts) vector table.

- Status register (SR)

Bit:	31	30	29	28	27	26	25	24	23	22	21	20	19	18	17	16
	-	-	-	-	-	-	-	-	-	-	-	-	-	-	-	-
Initial value:	0	0	0	0	0	0	0	0	0	0	0	0	0	0	0	0
R/W:	R	R	R	R	R	R	R	R	R	R	R	R	R	R	R	R
Bit:	15	14	13	12	11	10	9	8	7	6	5	4	3	2	1	0
	-	-	-	-	-	-	M	Q	I[3:0]			-	-	S	T	
Initial value:	0	0	0	0	0	0	-	-	1	1	1	1	0	0	-	-
R/W:	R	R	R	R	R	R	R/W	R/W	R/W	R/W	R/W	R/W	R	R	R/W	R/W

Bit	Bit name	Default	Read/Write	Description
31 to 10	—	All 0	R	Reserved These bits are always read as 0. The write value should always be 0.
9	M	Undefined	R/W	Used by the DIV0U, DIV0S, and DIV1 instructions.
8	Q	Undefined	R/W	Used by the DIV0U, DIV0S, and DIV1 instructions.
7 to 4	I[3:0]	1111	R/W	Interrupt Mask
3, 2	—	All 0	R	Reserved These bits are always read as 0. The write value should always be 0.

Bit	Bit name	Default	Read/Write	Description
1	S	Undefined	R/W	S Bit Used by the multiply and accumulate instruction.
0	T	Undefined	R/W	T Bit Indicates true (1) or false (0) in the following instructions: MOVT, CMP/cond, TAS, TST, BT (BT/S), BF (BF/S), SETT, CLRT Indicates carry, borrow, overflow, or underflow in the following instructions: ADDV, ADDC, SUBV, SUBC, NEGC, DIV0U, DIV0S, DIV1, SHAR, SHAL, SHLR, SHLL, ROTR, ROTL, ROTCR, ROTCL

- Global-base register (GBR)
This register indicates a base address in GBR indirect addressing mode. The GBR indirect addressing mode is used for data transfer of the on-chip peripheral module registers and logic operations.
- Vector-base register (VBR)
This register indicates the base address of the exception handling vector table.

2.2.3 System Registers

There are four 32-bit system registers, designated two multiply and accumulate registers (MACH and MACL), a procedure register (PR), and program counter (PC).

- Multiply and accumulate registers (MACH and MACL)
This register stores the results of multiplication and multiply-and-accumulate operation.
- Procedure register (PR)
This register stores the return-destination address from subroutine procedures.
- Program counter (PC)
The PC indicates the point which is four bytes (two instructions) after the current execution instruction.

2.2.4 Initial Values of Registers

Table 2.1 lists the initial values of registers after a reset.

Table 2.1 Initial Values of Registers

Type of register	Register	Default
General register	R0 to R14	Undefined
	R15 (SP)	SP value set in the exception handling vector table
Control register	SR	I3 to I0: 1111 (H'F) Reserved bits: 0 Other bits: Undefined
	GBR	Undefined
	VBR	H'00000000
System register	MACH, MACL, PR	Undefined
	PC	PC value set in the exception handling vector table

2.3 Data Formats

2.3.1 Register Data Format

The size of register operands is always longwords (32 bits). When loading byte (8 bits) or word (16 bits) data in memory into a register, the data is sign-extended to longword and stored in the register.

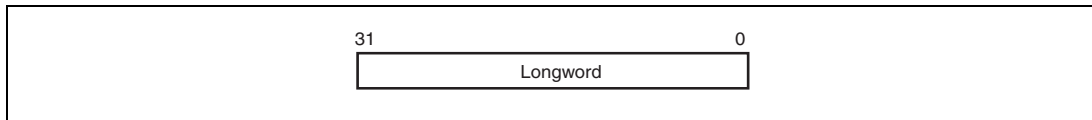

Figure 2.2 Register Data Format

2.3.2 Memory Data Formats

Memory data formats are classified into bytes, words, and longwords. Byte data can be accessed from any address. Locate, however, word data at an address $2n$, longword data at $4n$. Otherwise, an address error will occur if an attempt is made to access word data starting from an address other than $2n$ or longword data starting from an address other than $4n$. In such cases, the data accessed cannot be guaranteed. The hardware stack area, pointed by the hardware stack pointer (SP, R15), uses only longword data starting from address $4n$ because this area holds the program counter and status register.

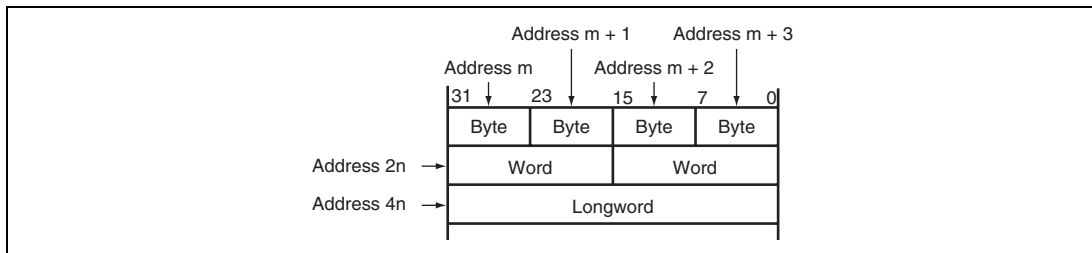

Figure 2.3 Memory Data Format

2.3.3 Immediate Data Formats

Immediate data of eight bits is placed in the instruction code.

For the MOV, ADD, and CMP/EQ instructions, the immediate data is sign-extended to longword and then calculated. For the TST, AND, OR, and XOR instructions, the immediate data is zero-extended to longword and then calculated. Thus, if the immediate data is used for the AND instruction, the upper 24 bits in the destination register are always cleared.

The immediate data of word or longword is not placed in the instruction code. It is placed in a table in memory. The table in memory is accessed by the MOV immediate data instruction in PC relative addressing mode with displacement.

2.4 Features of Instructions

2.4.1 RISC Type

The instructions are RISC-type instructions with the following features:

Fixed 16-Bit Length: All instructions have a fixed length of 16 bits. This improves program code efficiency.

One Instruction per Cycle: Since pipelining is used, basic instructions can be executed in one cycle.

Data Size: The basic data size for operations is longword. Byte, word, or longword can be selected as the memory access size. Byte or word data in memory is sign-extended to longword and then calculated. Immediate data is sign-extended to longword for arithmetic operations or zero-extended to longword size for logical operations.

Table 2.2 Word Data Sign Extension

CPU in this LSI	Description	Example of Other CPUs
MOV.W @ (disp,PC),R1	Sign-extended to 32 bits, R1 becomes H'00001234, and is then operated on by the ADD instruction.	ADD.W #H'1234,R0
ADD R1,R0		
.....		
.DATA.W H'1234		

Note: Immediate data is accessed by @ (disp,PC).

Load/Store Architecture: Basic operations are executed between registers. In operations involving memory, data is first loaded into a register (load/store architecture). However, bit manipulation instructions such as AND are executed directly in memory.

Delayed Branching: Unconditional branch instructions means the delayed branch instructions. With a delayed branch instruction, the branch is made after execution of the instruction immediately following the delayed branch instruction. This minimizes disruption of the pipeline when a branch is made. The conditional branch instructions have two types of instructions: conditional branch instructions and delayed branch instructions.

Table 2.3 Delayed Branch Instructions

CPU in this LSI	Description	Example of Other CPUs
BRA TRGET	ADD is executed before branch to TRGET.	ADD.W R1,R0
ADD R1,R0		BRA TRGET

Multiply/Multiply-and-Accumulate Operations: A $16 \times 16 \rightarrow 32$ multiply operation is executed in one to two cycles, and a $16 \times 16 + 64 \rightarrow 64$ multiply-and-accumulate operation in two to three cycles. A $32 \times 32 \rightarrow 64$ multiply operation and a $32 \times 32 + 64 \rightarrow 64$ multiply-and-accumulate operation are each executed in two to four cycles.

T Bit: The result of a comparison is indicated by the T bit in SR, and a conditional branch is performed according to whether the result is True or False. Processing speed has been improved by keeping the number of instructions that modify the T bit to a minimum.

Table 2.4 T Bit

CPU in this LSI	Description	Example of Other CPUs
CMP/GE R1,R0	When $R0 \geq R1$, the T bit is set.	CMP.W R1,R0
BT TRGET0	When $R0 \geq R1$, a branch is made to TRGET0.	BGE TRGET0
BF TRGET1	When $R0 < R1$, a branch is made to TRGET1.	BLT TRGET1
ADD #-1,R0	The T bit is not changed by ADD.	SUB.W #1,R0
CMP/EQ #0,R0	When $R0 = 0$, the T bit is set.	BEQ TRGET
BT TRGET	A branch is made when $R0 = 0$.	

Immediate Data: 8-bit immediate data is placed in the instruction code. Word and longword immediate data is not placed in the instruction code. It is placed in a table in memory. The table in memory is accessed with the MOV immediate data instruction using PC relative addressing mode with displacement.

Table 2.5 Access to Immediate Data

Type	This LSI's CPU	Example of Other CPU
8-bit immediate	MOV #H'12,R0	MOV.B #H'12,R0
16-bit immediate	MOV.W @(disp,PC),R0DATA.W H'1234	MOV.W #H'1234,R0
32-bit immediate	MOV.L @(disp,PC),R0DATA.L H'12345678	MOV.L #H'12345678,R0

Note: Immediate data is accessed by @(disp,PC).

Absolute Addresses: When data is accessed by absolute address, place the absolute address value in a table in memory beforehand. The absolute address value is transferred to a register using the method whereby immediate data is loaded when an instruction is executed, and the data is accessed using the register indirect addressing mode.

Table 2.6 Access to Absolute Address

Type	CPU in this LSI	Example of Other CPUs
Absolute address	MOV.L @(disp,PC),R1 MOV.B @R1,R0DATA.L H'12345678	MOV.B @H'12345678,R0

Note: Immediate data is referenced by @(disp,PC).

16-Bit/32-Bit Displacement: When data is accessed using the 16- or 32-bit displacement addressing mode, the displacement value is placed in a table in memory beforehand. Using the method whereby immediate data is loaded when an instruction is executed, this value is transferred to a register and the data is accessed using index register indirect addressing mode.

Table 2.7 Access with Displacement

Type	CPU in this LSI	Example of Other CPUs
16-bit displacement	MOV.W @(disp,PC),R0 MOV.W @(R0,R1),R2DATA.W H'1234	MOV.W @(H'1234,R1),R2

Note: Immediate data is referenced by @(disp,PC).

2.4.2 Addressing Modes

Table 2.8 lists addressing modes and effective address calculation methods.

Table 2.8 Addressing Modes and Effective Addresses

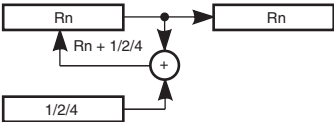
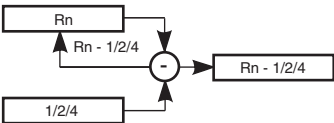
Addressing Mode	Instruction Format	Effective Address Calculation Method	Calculation Formula
Register direct	Rn	Effective address is register Rn. (Operand is register Rn contents.)	—
Register indirect	@Rn	Effective address is register Rn contents. 	Rn
Register indirect with post-increment	@Rn+	Effective address is register Rn contents. A constant is added to Rn after instruction execution: 1 for a byte operand, 2 for a word operand, 4 for a longword operand. 	Rn After instruction execution Byte: $Rn + 1 \rightarrow Rn$ Word: $Rn + 2 \rightarrow Rn$ Longword: $Rn + 4 \rightarrow Rn$
Register indirect with pre-decrement	@-Rn	Effective address is register Rn contents, decremented by a constant beforehand: 1 for a byte operand, 2 for a word operand, 4 for a longword operand. 	Byte: $Rn - 1 \rightarrow Rn$ Word: $Rn - 2 \rightarrow Rn$ Longword: $Rn - 4 \rightarrow Rn$ (Instruction executed with Rn after calculation)

Addressing Mode	Instruction Format	Effective Address Calculation Method	Calculation Formula
Register indirect with displacement	@(disp:4, Rn)	Effective address is register Rn contents with 4-bit displacement disp added. After disp is zero-extended, it is multiplied by 1 (byte), 2 (word), or 4 (longword), according to the operand size.	Byte: $Rn + disp$ Word: $Rn + disp \times 2$ Longword: $Rn + disp \times 4$
Index register indirect	@(R0, Rn)	Effective address is sum of register Rn and R0 contents.	$Rn + R0$
GBR indirect with displacement	@(disp:8, GBR)	Effective address is register GBR contents with 8-bit displacement disp added. After disp is zero-extended, it is multiplied by 1 (byte), 2 (word), or 4 (longword), according to the operand size.	Byte: $GBR + disp$ Word: $GBR + disp \times 2$ Longword: $GBR + disp \times 4$
Index GBR indirect	@(R0, GBR)	Effective address is sum of register GBR and R0 contents.	$GBR + R0$

Addressing Mode	Instruction Format	Effective Address Calculation Method	Calculation Formula
PC relative with displacement	@(disp:8, PC)	Effective address is PC with 8-bit displacement disp added. After disp is zero-extended, it is multiplied by 2 (word) or 4 (longword), according to the operand size. With a longword operand, the lower 2 bits of PC are masked.	Word: $PC + disp \times 2$ Longword: $PC \& H'FFFFFFFC + disp \times 4$
		<p style="text-align: center;">*With longword operand</p>	
PC relative	disp:8	Effective address is PC with 8-bit displacement disp added after being sign-extended and multiplied by 2.	$PC + disp \times 2$
	disp:12	Effective address is PC with 12-bit displacement disp added after being sign-extended and multiplied by 2.	$PC + disp \times 2$

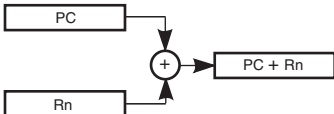
Addressing Mode	Instruction Format	Effective Address Calculation Method	Calculation Formula
PC relative	Rn	Effective address is sum of PC and Rn. 	PC + Rn
Immediate	#imm:8	8-bit immediate data imm of TST, AND, OR, or XOR instruction is zero-extended.	—
	#imm:8	8-bit immediate data imm of MOV, ADD, or CMP/EQ instruction is sign-extended.	—
	#imm:8	8-bit immediate data imm of TRAPA instruction is zero-extended and multiplied by 4.	—

2.4.3 Instruction Formats

This section describes the instruction formats, and the meaning of the source and destination operands. The meaning of the operands depends on the instruction code. The following symbols are used in the table.

xxxx: Instruction code

mmmm: Source register

nnnn: Destination register

iiii: Immediate data

dddd: Displacement

Table 2.9 Instruction Formats

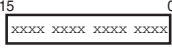
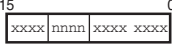
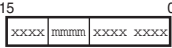
Instruction Format	Source Operand	Destination Operand	Sample Instruction
0 type 	—	—	NOP
n type 	—	nnnn: register direct	MOVT Rn
	Control register or system register	nnnn: register direct	STS MACH,Rn
	Control register or system register	nnnn: pre-decrement register indirect	STC.L SR,@-Rn
m type 	mmmm: register direct	Control register or system register	LDC Rm,SR
	mmmm: post-increment register indirect	Control register or system register	LDC.L @Rm+,SR
	mmmm: register indirect	—	JMP @Rm
	PC relative using Rm	—	BRAF Rm

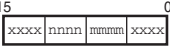
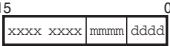
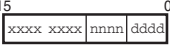
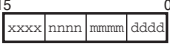
Instruction Format	Source Operand	Destination Operand	Sample Instruction
nm type 	mmmm: register direct	nnnn: register direct	ADD Rm,Rn
	mmmm: register direct	nnnn: register indirect	MOV.L Rm,@Rn
	mmmm: post-increment register indirect (multiply-and-accumulate operation) nnnn: * post-increment register indirect (multiply-and-accumulate operation)	MACH, MACL	MAC.W @Rm+,@Rn+
	mmmm: post-increment register indirect	nnnn: register direct	MOV.L @Rm+,Rn
	mmmm: register direct	nnnn: pre-decrement register indirect	MOV.L Rm,@-Rn
	mmmm: register direct	nnnn: index register indirect	MOV.L Rm,@(R0,Rn)
md type 	mmmmdddd: register indirect with displacement	R0 (register direct)	MOV.B @(disp,Rm),R0
nd4 type 	R0 (register direct)	nnnndddd: register indirect with displacement	MOV.B R0,@(disp,Rn)
nmd type 	mmmm: register direct	nnnndddd: register indirect with displacement	MOV.L Rm,@(disp,Rn)
	mmmmdddd: register indirect with displacement	nnnn: register direct	MOV.L @(disp,Rm),Rn

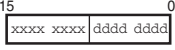
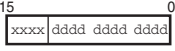
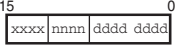
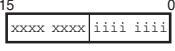
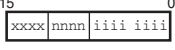
Instruction Format	Source Operand	Destination Operand	Sample Instruction
d type 	ddddddd: GBR indirect with displacement	R0 (register direct)	MOV.L @(disp,GBR),R0
	R0 (register direct)	ddddddd: GBR indirect with displacement	MOV.L R0,@(disp,GBR)
	ddddddd: PC relative with displacement	R0 (register direct)	MOVA @(disp,PC),R0
	—	ddddddd: PC relative	BF label
d12 type 	—	ddddddddddd: PC relative	BRA label (label=disp+PC)
nd8 type 	ddddddd: PC relative with displacement	nnnn: register direct	MOV.L @(disp,PC),Rn
i type 	iiiiiii: immediate	Index GBR indirect	AND.B #imm,@(R0,GBR)
	iiiiiii: immediate	R0 (register direct)	AND #imm,R0
	iiiiiii: immediate	—	TRAPA #imm
ni type 	iiiiiii: immediate	nnnn: register direct	ADD #imm,Rn

Note: * In multiply and accumulate instructions, nnnn is the source register.

2.5 Instruction Set

2.5.1 Instruction Set by Type

Table 2.10 lists the instructions classified by type.

Table 2.10 Instruction Types

Type	Kinds of Instruction	Op Code	Function	Number of Instructions
Data transfer instructions	5	MOV	Data transfer Immediate data transfer Peripheral module data transfer Structure data transfer	39
		MOVA	Effective address transfer	
		MOVT	T bit transfer	
		SWAP	Upper/lower swap	
		XTRCT	Extraction of middle of linked registers	
Arithmetic operation instructions	21	ADD	Binary addition	33
		ADDC	Binary addition with carry	
		ADDV	Binary addition with overflow	
		CMP/cond	Comparison	
		DIV1	Division	
		DIV0S	Signed division initialization	
		DIV0U	Unsigned division initialization	
		DMULS	Signed double-precision multiplication	
		DMULU	Unsigned double-precision multiplication	
		DT	Decrement and test	
		EXTS	Sign extension	
		EXTU	Zero extension	
		MAC	Multiply-and-accumulate, double-precision multiply-and-accumulate	
		MUL	Double-precision multiplication	

Type	Kinds of Instruction	Op Code	Function	Number of Instructions
Arithmetic operation instructions	21	MULS	Signed multiplication	33
		MULU	Unsigned multiplication	
		NEG	Sign inversion	
		NEGC	Sign inversion with borrow	
		SUB	Binary subtraction	
		SUBC	Binary subtraction with carry	
		SUBV	Binary subtraction with underflow	
Logic operation instructions	6	AND	Logical AND	14
		NOT	Bit inversion	
		OR	Logical OR	
		TAS	Memory test and bit setting	
		TST	T bit setting for logical AND	
		XOR	Exclusive logical OR	
Shift instructions	10	ROTL	1-bit left shift	14
		ROTR	1-bit right shift	
		ROTCL	1-bit left shift with T bit	
		ROTCR	1-bit right shift with T bit	
		SHAL	Arithmetic 1-bit left shift	
		SHAR	Arithmetic 1-bit right shift	
		SHLL	Logical 1-bit left shift	
		SHLLn	Logical n-bit left shift	
		SHLR	Logical 1-bit right shift	
		SHLRn	Logical n-bit right shift	

Type	Kinds of Instruction	Op Code	Function	Number of Instructions
Branch instructions	9	BF	Conditional branch, delayed conditional branch (T = 0)	11
		BT	Conditional branch, delayed conditional branch (T = 1)	
		BRA	Unconditional branch	
		BRAF	Unconditional branch	
		BSR	Branch to subroutine procedure	
		BSRF	Branch to subroutine procedure	
		JMP	Unconditional branch	
		JSR	Branch to subroutine procedure	
		RTS	Return from subroutine procedure	
System control instructions	11	CLRT	T bit clear	31
		CLRMAC	MAC register clear	
		LDC	Load into control register	
		LDS	Load into system register	
		NOP	No operation	
		RTE	Return from exception handling	
		SETT	T bit setting	
		SLEEP	Transition to power-down mode	
		STC	Store from control register	
		STS	Store from system register	
	TRAPA	Trap exception handling		
Total:	62			142

The instruction code, operation, and execution cycles of the instructions are listed in the following tables, classified by type.

Instruction	Instruction Code	Summary of Operation	Execution Cycles	T Bit
Indicated by mnemonic.	Indicated in MSB ↔ LSB order.	Indicates summary of operation.	Value when no wait cycles are inserted* ¹	Value of T bit after instruction is executed Explanation of Symbols —: No change
Explanation of Symbols	Explanation of Symbols	Explanation of Symbols		
OP.Sz SRC, DEST	mmmm: Source register	→, ←: Transfer direction		
OP: Operation code	nmmm: Destination register	(xx): Memory operand		
Sz: Size	0000: R0	M/Q/T: Flag bits in SR		
SRC: Source	0001: R1	&: Logical AND of each bit		
DEST: Destination	: Logical OR of each bit		
Rm: Source register	1111: R15	^: Exclusive logical OR of each bit		
Rn: Destination register	iiii: Immediate data	-: Logical NOT of each bit		
imm: Immediate data	dddd: Displacement	<<n: n-bit left shift		
disp: Displacement* ²		>>n: n-bit right shift		

- Notes: 1. The table shows the minimum number of execution states. In practice, the number of instruction execution states will be increased in cases such as the following:
- When there is contention between an instruction fetch and a data access
 - When the destination register of a load instruction (memory → register) is also used by the following instruction
2. Scaled (×1, ×2, or ×4) according to the instruction operand size, etc.
For details, see SH-1/SH-2/SH-DSP Software Manual.

2.5.2 Data Transfer Instructions

Table 2.11 Data Transfer Instructions

Instruction	Operation	Code	Execution Cycles	T Bit
MOV #imm, Rn	imm → Sign extension → Rn	1110nnnniiiiiii	1	—
MOV.W @(disp, PC), Rn	(disp × 2 + PC) → Sign extension → Rn	1001nnnnddddddd	1	—
MOV.L @(disp, PC), Rn	(disp × 4 + PC) → Rn	1101nnnnddddddd	1	—
MOV Rm, Rn	Rm → Rn	0110nnnnmmmm0011	1	—
MOV.B Rm, @Rn	Rm → (Rn)	0010nnnnmmmm0000	1	—
MOV.W Rm, @Rn	Rm → (Rn)	0010nnnnmmmm0001	1	—
MOV.L Rm, @Rn	Rm → (Rn)	0010nnnnmmmm0010	1	—
MOV.B @Rm, Rn	(Rm) → Sign extension → Rn	0110nnnnmmmm0000	1	—
MOV.W @Rm, Rn	(Rm) → Sign extension → Rn	0110nnnnmmmm0001	1	—
MOV.L @Rm, Rn	(Rm) → Rn	0110nnnnmmmm0010	1	—
MOV.B Rm, @-Rn	Rn-1 → Rn, Rm → (Rn)	0010nnnnmmmm0100	1	—
MOV.W Rm, @-Rn	Rn-2 → Rn, Rm → (Rn)	0010nnnnmmmm0101	1	—
MOV.L Rm, @-Rn	Rn-4 → Rn, Rm → (Rn)	0010nnnnmmmm0110	1	—
MOV.B @Rm+, Rn	(Rm) → Sign extension → Rn, Rm + 1 → Rm	0110nnnnmmmm0100	1	—
MOV.W @Rm+, Rn	(Rm) → Sign extension → Rn, Rm + 2 → Rm	0110nnnnmmmm0101	1	—
MOV.L @Rm+, Rn	(Rm) → Rn, Rm + 4 → Rm	0110nnnnmmmm0110	1	—
MOV.B R0, @(disp, Rn)	R0 → (disp + Rn)	10000000nnnnddd	1	—
MOV.W R0, @(disp, Rn)	R0 → (disp × 2 + Rn)	10000001nnnnddd	1	—
MOV.L Rm, @(disp, Rn)	Rm → (disp × 4 + Rn)	0001nnnnmmmmddd	1	—
MOV.B @(disp, Rm), R0	(disp + Rm) → Sign extension → R0	10000100mmmmddd	1	—
MOV.W @(disp, Rm), R0	(disp × 2 + Rm) → Sign extension → R0	10000101mmmmddd	1	—
MOV.L @(disp, Rm), Rn	(disp × 4 + Rm) → Rn	0101nnnnmmmmddd	1	—

Instruction	Operation	Code	Execution Cycles	T Bit
MOV.B Rm,@(R0,Rn)	Rm → (R0 + Rn)	0000nnnnmmmm0100	1	—
MOV.W Rm,@(R0,Rn)	Rm → (R0 + Rn)	0000nnnnmmmm0101	1	—
MOV.L Rm,@(R0,Rn)	Rm → (R0 + Rn)	0000nnnnmmmm0110	1	—
MOV.B @(R0,Rm),Rn	(R0 + Rm) → Sign extension → Rn	0000nnnnmmmm1100	1	—
MOV.W @(R0,Rm),Rn	(R0 + Rm) → Sign extension → Rn	0000nnnnmmmm1101	1	—
MOV.L @(R0,Rm),Rn	(R0 + Rm) → Rn	0000nnnnmmmm1110	1	—
MOV.B R0,@(disp,GBR)	R0 → (disp + GBR)	11000000ddddddd	1	—
MOV.W R0,@(disp,GBR)	R0 → (disp × 2 + GBR)	11000001ddddddd	1	—
MOV.L R0,@(disp,GBR)	R0 → (disp × 4 + GBR)	11000010ddddddd	1	—
MOV.B @(disp,GBR),R0	(disp + GBR) → Sign extension → R0	11000100ddddddd	1	—
MOV.W @(disp,GBR),R0	(disp × 2 + GBR) → Sign extension → R0	11000101ddddddd	1	—
MOV.L @(disp,GBR),R0	(disp × 4 + GBR) → R0	11000110ddddddd	1	—
MOVA @(disp,PC),R0	disp × 4 + PC → R0	11000111ddddddd	1	—
MOVT Rn	T → Rn	0000nnnn00101001	1	—
SWAP.B Rm,Rn	Rm → Swap lowest two bytes → Rn	0110nnnnmmmm1000	1	—
SWAP.W Rm,Rn	Rm → Swap two consecutive words → Rn	0110nnnnmmmm1001	1	—
XTRCT Rm,Rn	Rm: Middle 32 bits of Rn → Rn	0010nnnnmmmm1101	1	—

2.5.3 Arithmetic Operation Instructions

Table 2.12 Arithmetic Operation Instructions

Instruction	Operation	Code	Execution Cycles	T Bit
ADD Rm, Rn	Rn + Rm → Rn	0011nnnnmmmm1100	1	—
ADD #imm, Rn	Rn + imm → Rn	0111nnnniiiiiii	1	—
ADDC Rm, Rn	Rn + Rm + T → Rn, Carry → T	0011nnnnmmmm1110	1	Carry
ADDV Rm, Rn	Rn + Rm → Rn, Overflow → T	0011nnnnmmmm1111	1	Overflow
CMP/EQ #imm, R0	If R0 = imm, 1 → T	10001000iiiiiii	1	Comparison result
CMP/EQ Rm, Rn	If Rn = Rm, 1 → T	0011nnnnmmmm0000	1	Comparison result
CMP/HS Rm, Rn	If Rn ≥ Rm with unsigned data, 1 → T	0011nnnnmmmm0010	1	Comparison result
CMP/GE Rm, Rn	If Rn ≥ Rm with signed data, 1 → T	0011nnnnmmmm0011	1	Comparison result
CMP/HI Rm, Rn	If Rn > Rm with unsigned data, 1 → T	0011nnnnmmmm0110	1	Comparison result
CMP/GT Rm, Rn	If Rn > Rm with signed data, 1 → T	0011nnnnmmmm0111	1	Comparison result
CMP/PZ Rn	If Rn ≥ 0, 1 → T	0100nnnn00010001	1	Comparison result
CMP/PL Rn	If Rn > 0, 1 → T	0100nnnn00010101	1	Comparison result
CMP/STR Rm, Rn	If Rn and Rm have an equivalent byte, 1 → T	0010nnnnmmmm1100	1	Comparison result
DIV1 Rm, Rn	Single-step division (Rn/Rm)	0011nnnnmmmm0100	1	Calculation result
DIV0S Rm, Rn	MSB of Rn → Q, MSB of Rm → M, M^Q → T	0010nnnnmmmm0111	1	Calculation result
DIV0U	0 → M/Q/T	000000000011001	1	0
DMULS.L Rm, Rn	Signed operation of Rn × Rm → MACH, MACL 32 × 32 → 64 bits	0011nnnnmmmm1101	2 to 5*	—

Instruction	Operation	Code	Execution Cycles	T Bit
DMULU.L Rm, Rn	Unsigned operation of $Rn \times Rm \rightarrow MACH$, MACL $32 \times 32 \rightarrow 64$ bits	0011nnnnmmmm0101	2 to 5*	—
DT Rn	$Rn - 1 \rightarrow Rn$, if $Rn = 0$, $1 \rightarrow T$, else $0 \rightarrow T$	0100nnnn00010000	1	Comparison result
EXTS.B Rm, Rn	A byte in Rm is sign-extended $\rightarrow Rn$	0110nnnnmmmm1110	1	—
EXTS.W Rm, Rn	A word in Rm is sign-extended $\rightarrow Rn$	0110nnnnmmmm1111	1	—
EXTU.B Rm, Rn	A byte in Rm is zero-extended $\rightarrow Rn$	0110nnnnmmmm1100	1	—
EXTU.W Rm, Rn	A word in Rm is zero-extended $\rightarrow Rn$	0110nnnnmmmm1101	1	—
MAC.L @Rm+, @Rn+	Signed operation of $(Rn) \times (Rm) + MAC \rightarrow MAC$, $32 \times 32 + 64 \rightarrow 64$ bits	0000nnnnmmmm1111	2 to 5*	—
MAC.W @Rm+, @Rn+	Signed operation of $(Rn) \times (Rm) + MAC \rightarrow MAC$, $16 \times 16 + 64 \rightarrow 64$ bits	0100nnnnmmmm1111	2 to 4*	—
MUL.L Rm, Rn	$Rn \times Rm \rightarrow MACL$ $32 \times 32 \rightarrow 32$ bits	0000nnnnmmmm0111	2 to 5*	—
MULS.W Rm, Rn	Signed operation of $Rn \times Rm \rightarrow MAC$ $16 \times 16 \rightarrow 32$ bits	0010nnnnmmmm1111	1 to 3*	—
MULU.W Rm, Rn	Unsigned operation of $Rn \times Rm \rightarrow MAC$ $16 \times 16 \rightarrow 32$ bits	0010nnnnmmmm1110	1 to 3*	—
NEG Rm, Rn	$0-Rm \rightarrow Rn$	0110nnnnmmmm1011	1	—
NEGC Rm, Rn	$0-Rm-T \rightarrow Rn$, Borrow $\rightarrow T$	0110nnnnmmmm1010	1	Borrow
SUB Rm, Rn	$Rn-Rm \rightarrow Rn$	0011nnnnmmmm1000	1	—
SUBC Rm, Rn	$Rn-Rm-T \rightarrow Rn$, Borrow $\rightarrow T$	0011nnnnmmmm1010	1	Borrow
SUBV Rm, Rn	$Rn-Rm \rightarrow Rn$, Underflow $\rightarrow T$	0011nnnnmmmm1011	1	Overflow

Note: * Indicates the number of execution cycles for normal operation.

2.5.4 Logic Operation Instructions

Table 2.13 Logic Operation Instructions

Instruction	Operation	Code	Execution Cycles	T Bit
AND Rm, Rn	$Rn \& Rm \rightarrow Rn$	0010nnnnmmmm1001	1	—
AND #imm, R0	$R0 \& imm \rightarrow R0$	11001001iiiiiii	1	—
AND.B #imm, @(R0, GBR)	$(R0 + GBR) \& imm \rightarrow (R0 + GBR)$	11001101iiiiiii	3	—
NOT Rm, Rn	$\sim Rm \rightarrow Rn$	0110nnnnmmmm0111	1	—
OR Rm, Rn	$Rn Rm \rightarrow Rn$	0010nnnnmmmm1011	1	—
OR #imm, R0	$R0 imm \rightarrow R0$	11001011iiiiiii	1	—
OR.B #imm, @(R0, GBR)	$(R0 + GBR) imm \rightarrow (R0 + GBR)$	11001111iiiiiii	3	—
TAS.B @Rn	If (Rn) is 0, $1 \rightarrow T$; $1 \rightarrow$ MSB of (Rn)	0100nnnn00011011	4	Test result
TST Rm, Rn	$Rn \& Rm$; if the result is 0, $1 \rightarrow T$	0010nnnnmmmm1000	1	Test result
TST #imm, R0	$R0 \& imm$; if the result is 0, $1 \rightarrow T$	11001000iiiiiii	1	Test result
TST.B #imm, @(R0, GBR)	$(R0 + GBR) \& imm$; if the result is 0, $1 \rightarrow T$	11001100iiiiiii	3	Test result
XOR Rm, Rn	$Rn \wedge Rm \rightarrow Rn$	0010nnnnmmmm1010	1	—
XOR #imm, R0	$R0 \wedge imm \rightarrow R0$	11001010iiiiiii	1	—
XOR.B #imm, @(R0, GBR)	$(R0 + GBR) \wedge imm \rightarrow (R0 + GBR)$	11001110iiiiiii	3	—

2.5.5 Shift Instructions

Table 2.14 Shift Instructions

Instruction	Operation	Code	Execution Cycles	T Bit
ROTL Rn	$T \leftarrow Rn \leftarrow \text{MSB}$	0100nnnn00000100	1	MSB
ROTR Rn	$\text{LSB} \rightarrow Rn \rightarrow T$	0100nnnn00000101	1	LSB
ROTCL Rn	$T \leftarrow Rn \leftarrow T$	0100nnnn00100100	1	MSB
ROTCR Rn	$T \rightarrow Rn \rightarrow T$	0100nnnn00100101	1	LSB
SHAL Rn	$T \leftarrow Rn \leftarrow 0$	0100nnnn00100000	1	MSB
SHAR Rn	$\text{MSB} \rightarrow Rn \rightarrow T$	0100nnnn00100001	1	LSB
SHLL Rn	$T \leftarrow Rn \leftarrow 0$	0100nnnn00000000	1	MSB
SHLR Rn	$0 \rightarrow Rn \rightarrow T$	0100nnnn00000001	1	LSB
SHLL2 Rn	$Rn \ll 2 \rightarrow Rn$	0100nnnn00001000	1	—
SHLR2 Rn	$Rn \gg 2 \rightarrow Rn$	0100nnnn00001001	1	—
SHLL8 Rn	$Rn \ll 8 \rightarrow Rn$	0100nnnn00011000	1	—
SHLR8 Rn	$Rn \gg 8 \rightarrow Rn$	0100nnnn00011001	1	—
SHLL16 Rn	$Rn \ll 16 \rightarrow Rn$	0100nnnn00101000	1	—
SHLR16 Rn	$Rn \gg 16 \rightarrow Rn$	0100nnnn00101001	1	—

2.5.6 Branch Instructions

Table 2.15 Branch Instructions

Instruction	Operation	Code	Execution Cycles	T Bit
BF label	If T = 0, disp × 2 + PC → PC; if T = 1, nop	10001011dddddddd	3/1*	—
BF/S label	Delayed branch, if T = 0, disp × 2 + PC → PC; if T = 1, nop	10001111dddddddd	2/1*	—
BT label	If T = 1, disp × 2 + PC → PC; if T = 0, nop	10001001dddddddd	3/1*	—
BT/S label	Delayed branch, if T = 1, disp × 2 + PC → PC; if T = 0, nop	10001101dddddddd	2/1*	—
BRA label	Delayed branch, disp × 2 + PC → PC	1010dddddddddddd	2	—
BRAF Rm	Delayed branch, Rm + PC → PC	0000mmmm00100011	2	—
BSR label	Delayed branch, PC → PR, disp × 2 + PC → PC	1011dddddddddddd	2	—
BSRF Rm	Delayed branch, PC → PR, Rm + PC → PC	0000mmmm00000011	2	—
JMP @Rm	Delayed branch, Rm → PC	0100mmmm00101011	2	—
JSR @Rm	Delayed branch, PC → PR, Rm → PC	0100mmmm00001011	2	—
RTS	Delayed branch, PR → PC	0000000000001011	2	—

Note: * One cycle when the branch is not executed.

2.5.7 System Control Instructions

Table 2.16 System Control Instructions

Instruction	Operation	Code	Execution Cycles	T Bit
CLRT	0 → T	0000000000001000	1	0
CLRMAC	0 → MACH, MACL	0000000000101000	1	—
LDC Rm, SR	Rm → SR	0100mmmm00001110	6	LSB
LDC Rm, GBR	Rm → GBR	0100mmmm00011110	4	—
LDC Rm, VBR	Rm → VBR	0100mmmm00101110	4	—
LDC.L @Rm+, SR	(Rm) → SR, Rm + 4 → Rm	0100mmmm00000111	8	LSB
LDC.L @Rm+, GBR	(Rm) → GBR, Rm + 4 → Rm	0100mmmm00010111	4	—
LDC.L @Rm+, VBR	(Rm) → VBR, Rm + 4 → Rm	0100mmmm00100111	4	—
LDS Rm, MACH	Rm → MACH	0100mmmm00001010	1	—
LDS Rm, MACL	Rm → MACL	0100mmmm00011010	1	—
LDS Rm, PR	Rm → PR	0100mmmm00101010	1	—
LDS.L @Rm+, MACH	(Rm) → MACH, Rm + 4 → Rm	0100mmmm00000110	1	—
LDS.L @Rm+, MACL	(Rm) → MACL, Rm + 4 → Rm	0100mmmm00010110	1	—
LDS.L @Rm+, PR	(Rm) → PR, Rm + 4 → Rm	0100mmmm00100110	1	—
NOP	No operation	000000000001001	1	—
RTE	Delayed branch, Stack area → PC/SR	0000000000101011	5	—
SETT	1 → T	000000000011000	1	1
SLEEP	Sleep	000000000011011	4*	—
STC SR, Rn	SR → Rn	0000nnnn00000010	1	—
STC GBR, Rn	GBR → Rn	0000nnnn00010010	1	—
STC VBR, Rn	VBR → Rn	0000nnnn00100010	1	—
STC.L SR, @-Rn	Rn-4 → Rn, SR → (Rn)	0100nnnn00000011	1	—
STC.L GBR, @-Rn	Rn-4 → Rn, GBR → (Rn)	0100nnnn00010011	1	—
STC.L VBR, @-Rn	Rn-4 → Rn, VBR → (Rn)	0100nnnn00100011	1	—

Instruction		Operation	Code	Execution Cycles	T Bit
STS	MACH, Rn	MACH → Rn	0000nnnn00001010	1	—
STS	MACL, Rn	MACL → Rn	0000nnnn00011010	1	—
STS	PR, Rn	PR → Rn	0000nnnn00101010	1	—
STS.L	MACH, @-Rn	Rn-4 → Rn, MACH → (Rn)	0100nnnn00000010	1	—
STS.L	MACL, @-Rn	Rn-4 → Rn, MACL → (Rn)	0100nnnn00010010	1	—
STS.L	PR, @-Rn	Rn-4 → Rn, PR → (Rn)	0100nnnn00100010	1	—
TRAPA	#imm	PC/SR → Stack area, (imm × 4 + VBR) → PC	11000011iiiiiiii	8	—

Note: * Number of execution cycles until this LSI enters sleep mode.

About the number of execution cycles:

The table lists the minimum number of execution cycles. In practice, the number of execution cycles will be increased depending on the conditions such as:

- When there is a conflict between instruction fetch and data access
- When the destination register of a load instruction (memory → register) is also used by the instruction immediately after the load instruction.

2.6 Processing States

The CPU has the five processing states: reset, exception handling, bus release, program execution, and power-down. Figure 2.4 shows the CPU state transition.

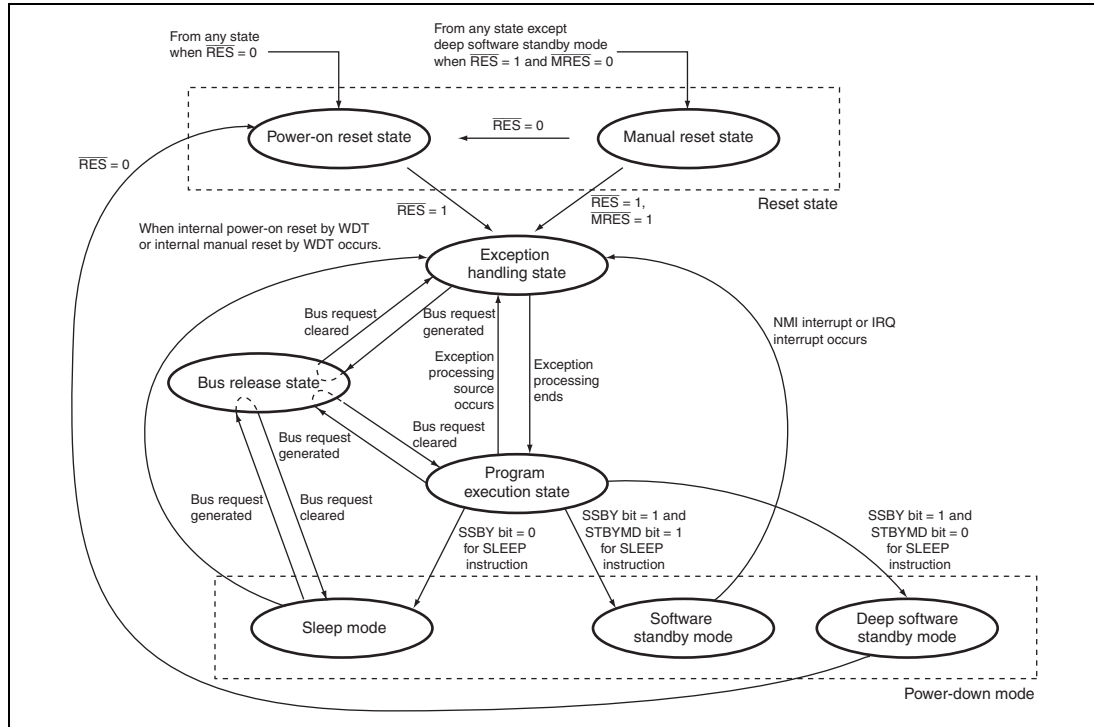

Figure 2.4 Transitions between Processing States

- **Reset state**

The CPU is reset. When the $\overline{\text{RES}}$ pin is low, the CPU enters the power-on reset state. When the $\overline{\text{RES}}$ pin is high and $\overline{\text{MRES}}$ pin is low, the CPU enters the manual reset state.
- **Exception handling state**

This state is a transitional state in which the CPU processing state changes due to a request for exception handling such as a reset or an interrupt.

When a reset occurs, the execution start address as the initial value of the program counter (PC) and the initial value of the stack pointer (SP) are fetched from the exception handling vector table. Then, a branch is made for the start address to execute a program.

When an interrupt occurs, the PC and status register (SR) are saved in the stack area pointed to by SP. The start address of an exception handling routine is fetched from the exception handling vector table and a branch to the address is made to execute a program.

Then the processing state enters the program execution state.
- **Program execution state**

The CPU executes programs sequentially.
- **Power-down state**

The CPU stops to reduce power consumption. The SLEEP instruction makes the CPU enter sleep mode, software standby mode, or deep software standby mode.
- **Bus release state**

In the bus release state, the CPU releases access rights to the bus to the device that has requested them.

Section 3 MCU Operating Modes

3.1 Selection of Operating Modes

This LSI has four MCU operating modes and three on-chip flash memory programming modes. The operating mode is determined by the setting of FWE, MD1, and MD0 pins. Table 3.1 shows the allowable combinations of these pin settings; do not set these pins in the other way than the shown combinations.

When power is applied to the system, be sure to conduct power-on reset.

The MCU operating mode can be selected from MCU extension modes 0 to 2 and single chip mode. For the on-chip flash memory programming mode, boot mode, user boot mode, and user program mode which are on-chip programming modes are available.

Table 3.1 Selection of Operating Modes

Mode No.	Pin Setting			Mode Name	On-Chip ROM	Bus Width of CS0 Space	
	FWE	MD1	MD0* ¹			SH7146	SH7149
Mode 0	0	0	0	MCU extension mode 0	Not active	—	8
Mode 1	0	0	1	MCU extension mode 1	Not active	—	16
Mode 2	0	1	0	MCU extension mode 2	Active	—	Set by CS0BCR in BSC
Mode 3	0	1	1	Single chip mode	Active	—	—
Mode 4* ²	1	0	0	Boot mode	Active	—	—
Mode 5* ²	1	0	1	User boot mode	Active	—	Set by CS0BCR in BSC
Mode 6* ²	1	1	0	User programming mode	Active	—	Set by CS0BCR in BSC
Mode 7* ²	1	1	1				

Notes: 1. The SH7146 does not have the MD0 pin and only supports the following operating modes according to the combination of the FWE and MD1 pins.

Single chip mode: FWE pin = 0 and MD1 pin = 1

Boot mode: FWE pin = 1 and MD1 pin = 0

User programming mode: FWE pin = 1 and MD1 pin = 1

2. Flash memory programming mode.

3.2 Input/Output Pins

Table 3.2 describes the configuration of operating mode related pin.

Table 3.2 Pin Configuration

Pin Name	Input/Output	Function
MD0	Input	Designates operating mode through the level applied to this pin
MD1	Input	Designates operating mode through the level applied to this pin
FWE	Input	Enables, by hardware, programming/erasing of the on-chip flash memory

3.3 Operating Modes

3.3.1 Mode 0 (MCU Extension Mode 0)

CS0 space becomes external memory spaces with 8-bit bus width in SH7149.

3.3.2 Mode 1 (MCU Extension Mode 1)

CS0 space becomes external memory spaces with 16-bit bus width in SH7149.

3.3.3 Mode 2 (MCU Extension Mode 2)

The on-chip ROM is active and CS0 space can be used in this mode.

3.3.4 Mode 3 (Single Chip Mode)

All ports can be used in this mode, however the external address cannot be used.

3.4 Address Map

The address maps for the operating modes are shown in figures 3.1 and 3.2.

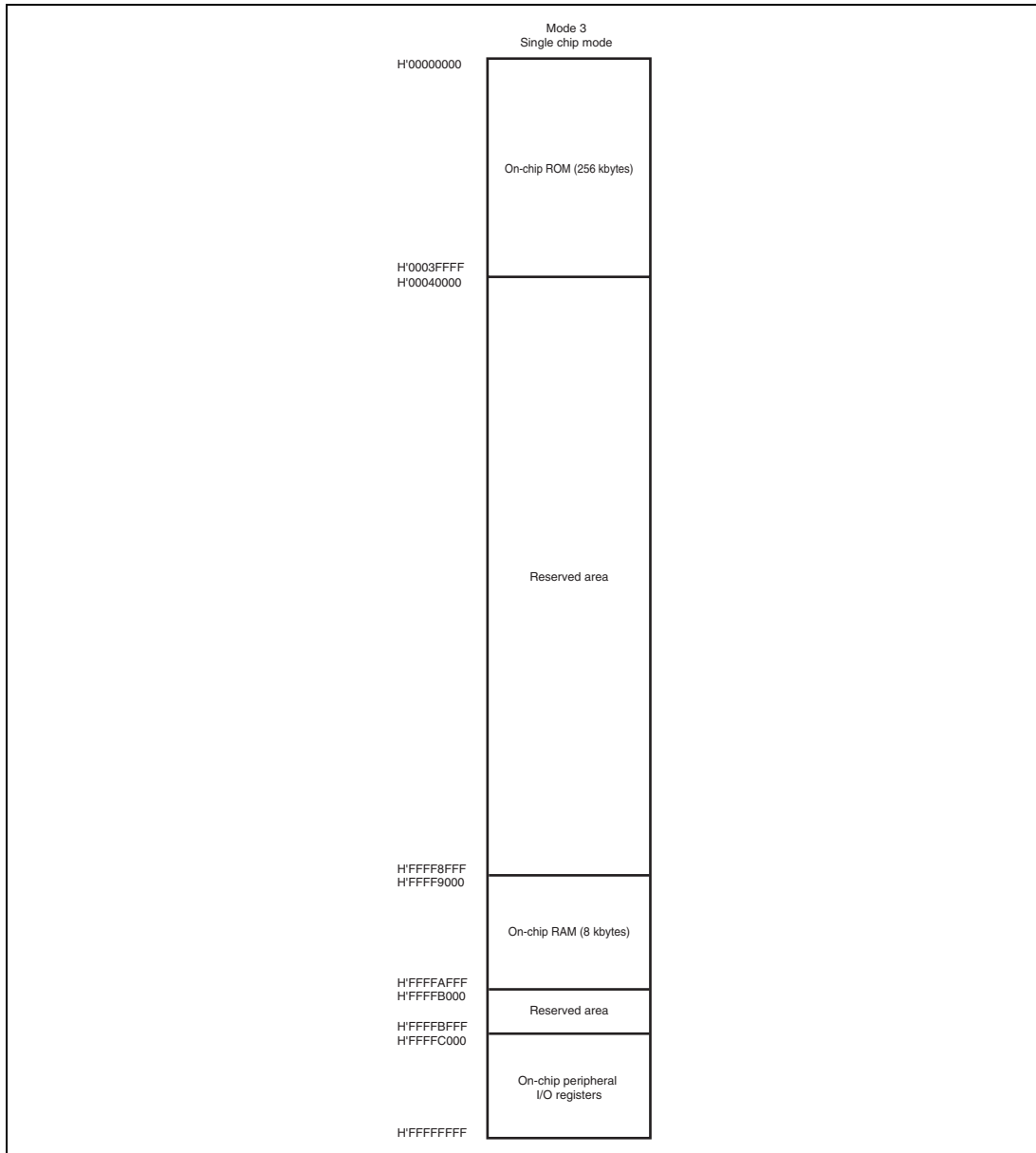

Figure 3.1 Address Map for Each Operating Mode in SH7146

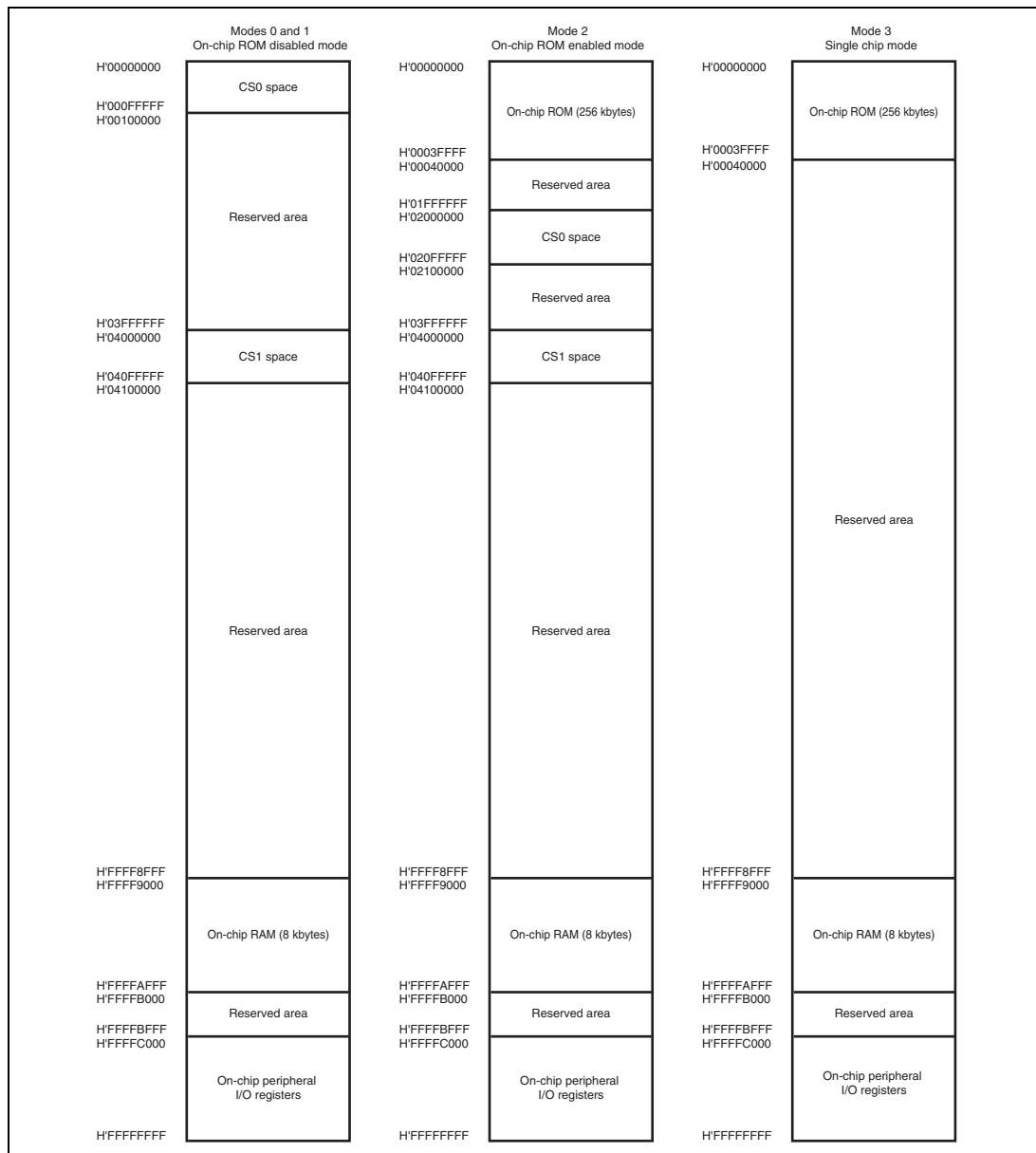

Figure 3.2 Address Map for Each Operating Mode in SH7149

3.5 Initial State in This LSI

In the initial state of this LSI, some of on-chip modules are set in module standby state for saving power. When operating these modules, clear module standby state according to the procedure in section 22, Power-Down Modes.

3.6 Note on Changing Operating Mode

When changing operating mode while power is applied to this LSI, make sure to do it in the power-on reset state (that is, the low level is applied to the $\overline{\text{RES}}$ pin).

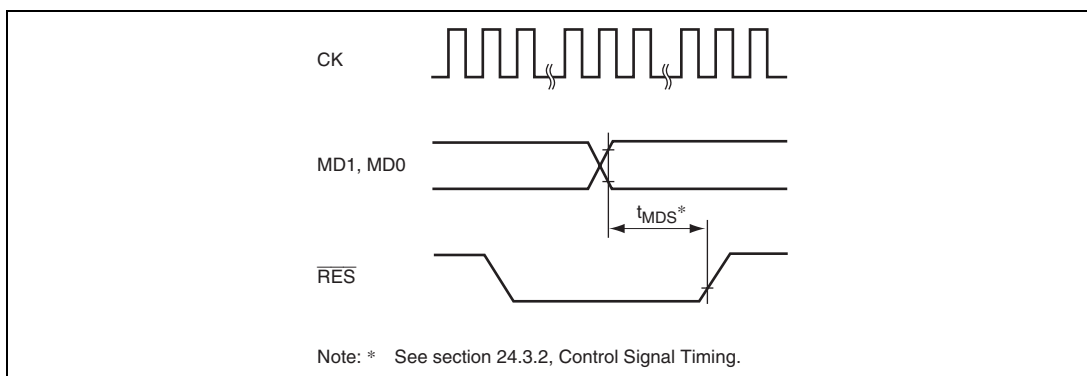

Figure 3.3 Reset Input Timing when Changing Operating Mode

Section 4 Clock Pulse Generator (CPG)

This LSI has a clock pulse generator (CPG) that generates an internal clock ($I\phi$), a bus clock ($B\phi$), a peripheral clock ($P\phi$), and clocks ($MI\phi$ and $MP\phi$) for the MTU2S and MTU2 modules. The CPG also controls power-down modes.

4.1 Features

- Five clocks generated independently
An internal clock ($I\phi$) for the CPU; a peripheral clock ($P\phi$) for the on-chip peripheral modules; a bus clock ($B\phi = CK$) for the external bus interface; a MTU2S clock ($MI\phi$) for the on-chip MTU2S module; and a MTU2 clock ($MP\phi$) for the on-chip MTU2 module.
- Frequency change function
Frequencies of the internal clock ($I\phi$), bus clock ($B\phi$), peripheral clock ($P\phi$), MTU2S clock ($MI\phi$), and MTU2 clock ($MP\phi$) can be changed independently using the divider circuit within the CPG. Frequencies are changed by software using the frequency control register (FRQCR) setting.
- Power-down mode control
The clock can be stopped in sleep mode and standby mode and specific modules can be stopped using the module standby function.
- Oscillation stop detection
If the clock supplied through the clock input pin stops for any reason, the timer pins can be automatically placed in the high-impedance state.

Figure 4.1 shows a block diagram of the clock pulse generator.

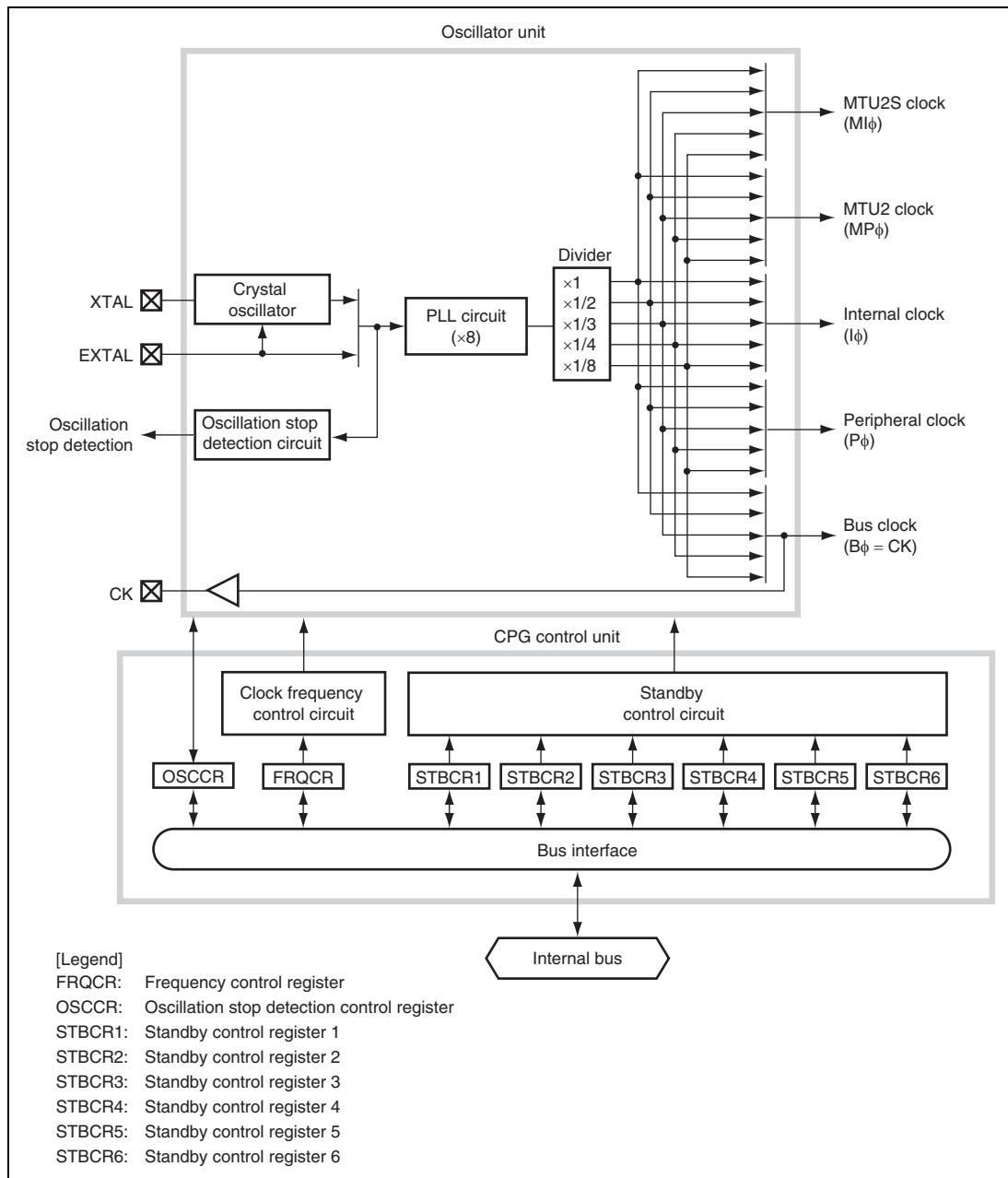

Figure 4.1 Block Diagram of Clock Pulse Generator

The clock pulse generator blocks function as follows:

PLL Circuit: The PLL circuit multiplies the clock frequency input from the crystal oscillator or the EXTAL pin by 8. The multiplication ratio is fixed at $\times 8$.

Crystal Oscillator: The crystal oscillator is an oscillator circuit when a crystal resonator is connected to the XTAL and EXTAL pins.

Divider: The divider generates clocks with the frequencies to be used by the internal clock ($I\phi$), bus clock ($B\phi$), peripheral clock ($P\phi$), MTU2S clock ($MI\phi$), and MTU2 clock ($MP\phi$).

The frequencies can be selected from 1, 1/2, 1/3, 1/4, and 1/8 times the frequency output from the PLL circuit. The division ratio should be specified in the frequency control register (FRQCR).

Oscillation Stop Detection Circuit: This circuit detects an abnormal condition in the crystal oscillator.

Clock Frequency Control Circuit: The clock frequency control circuit controls the clock frequency according to the setting in the frequency control register (FRQCR).

Standby Control Circuit: The standby control circuit controls the state of the on-chip oscillator circuit and other modules in sleep or standby mode.

Frequency Control Register (FRQCR): The frequency control register (FRQCR) has control bits for the frequency division ratios of the internal clock ($I\phi$), bus clock ($B\phi$), peripheral clock ($P\phi$), MTU2S clock ($MI\phi$), and MTU2 clock ($MP\phi$).

Oscillation Stop Detection Control Register (OSCCR): The oscillation stop detection control register (OSCCR) has an oscillation stop detection flag and a bit for selecting flag status output through an external pin.

Standby Control Registers 1 to 6 (STBCR1 to STBCR6): The standby control register (STBCR) has bits for controlling the power-down modes. For details, see section 22, Power-Down Modes.

Table 4.1 shows the operating clock for each module.

Table 4.1 Operating Clock for Each Module

Operating Clock	Operating Module	Operating Clock	Operating Module
Internal clock (I ϕ)	CPU	Peripheral clock (P ϕ)	POE
	UBC		SCI
	ROM		A/D
	RAM		CMT
			WDT
Bus clock (B ϕ)	BSC	MTU2 clock (MP ϕ)	MTU2
	DTC	MTU2S clock (MI ϕ)	MTU2S

4.2 Input/Output Pins

Table 4.2 shows the CPG pin configuration.

Table 4.2 Pin Configuration

Pin Name	Abbr.	I/O	Description
Crystal input/output pins (clock input pins)	XTAL	Output	Connects a crystal resonator.
	EXTAL	Input	Connects a crystal resonator or an external clock.
Clock output pin	CK	Output	Outputs an external clock.

Note: To use the clock output (CK) pin, appropriate settings may be needed for the pin in the pin function controller (PFC) in some cases. For details, refer to section 17, Pin Function Controller (PFC).

4.3 Clock Operating Mode

Table 4.3 shows the clock operating mode of this LSI.

Table 4.3 Clock Operating Mode

Clock Operating Mode	Clock I/O		PLL Circuit	Input to Divider
	Source	Output		
1	EXTAL input or crystal resonator	CK*	ON (×8)	×8

Note: * To output the clock through the clock output (CK) pin, appropriate settings should be made in the pin function controller (PFC). For details, refer to section 17, Pin Function Controller (PFC).

Mode 1: The frequency of the external clock input from the EXTAL pin is multiplied by 8 in the PLL circuit before being supplied to the on-chip modules in this LSI, which eliminates the need to generate a high-frequency clock outside the LSI. Since the input clock frequency ranging from 5 MHz to 12.5 MHz can be used, the internal clock ($I\phi$) frequency ranges from 10 MHz to 80 MHz.

Maximum operating frequencies:

$I\phi = 80$ MHz, $B\phi = 40$ MHz, $P\phi = 40$ MHz, $MI\phi = 80$ MHz, and $MP\phi = 40$ MHz

Table 4.4 shows the frequency division ratios that can be specified with FRQCR.

Table 4.4 Frequency Division Ratios Specifiable with FRQCR

PLL Multipli- cation Ratio	FRQCR Division Ratio Setting					Clock Ratio					Input Clock	Clock Frequency (MHz)*				
	I ϕ	B ϕ	P ϕ	MI ϕ	MP ϕ	I ϕ	B ϕ	P ϕ	MI ϕ	MP ϕ		I ϕ	B ϕ	P ϕ	MI ϕ	MP ϕ
	$\times 8$	1/8	1/8	1/8	1/8	1/8	1	1	1	1		1	10	10	10	10
	1/4	1/8	1/8	1/8	1/8	2	1	1	1	1		20	10	10	10	10
	1/4	1/8	1/8	1/4	1/8	2	1	1	2	1		20	10	10	20	10
	1/4	1/4	1/8	1/8	1/8	2	2	1	1	1		20	20	10	10	10
	1/4	1/4	1/8	1/4	1/8	2	2	1	2	1		20	20	10	20	10
	1/4	1/4	1/8	1/4	1/4	2	2	1	2	2		20	20	10	20	20
	1/4	1/4	1/4	1/4	1/4	2	2	2	2	2		20	20	20	20	20
	1/3	1/3	1/3	1/3	1/3	8/3	8/3	8/3	8/3	8/3		26	26	26	26	26
	1/2	1/8	1/8	1/8	1/8	4	1	1	1	1		40	10	10	10	10
	1/2	1/8	1/8	1/4	1/8	4	1	1	2	1		40	10	10	20	10
	1/2	1/8	1/8	1/2	1/8	4	1	1	4	1		40	10	10	40	10
	1/2	1/4	1/8	1/8	1/8	4	2	1	1	1		40	20	10	10	10
	1/2	1/4	1/8	1/4	1/8	4	2	1	2	1		40	20	10	20	10
	1/2	1/4	1/8	1/4	1/4	4	2	1	2	2		40	20	10	20	20
	1/2	1/4	1/8	1/2	1/8	4	2	1	4	1		40	20	10	40	10
	1/2	1/4	1/8	1/2	1/4	4	2	1	4	2		40	20	10	40	20
	1/2	1/4	1/4	1/4	1/4	4	2	2	2	2		40	20	20	20	20
	1/2	1/4	1/4	1/2	1/4	4	2	2	4	2		40	20	20	40	20
	1/2	1/2	1/8	1/8	1/8	4	4	1	1	1		40	40	10	10	10
	1/2	1/2	1/8	1/4	1/8	4	4	1	2	1		40	40	10	20	10
	1/2	1/2	1/8	1/4	1/4	4	4	1	2	2		40	40	10	20	20
	1/2	1/2	1/8	1/2	1/8	4	4	1	4	1		40	40	10	40	10
	1/2	1/2	1/8	1/2	1/4	4	4	1	4	2		40	40	10	40	20
	1/2	1/2	1/8	1/2	1/2	4	4	1	4	4		40	40	10	40	40
	1/2	1/2	1/4	1/4	1/4	4	4	2	2	2		40	40	20	20	20
	1/2	1/2	1/4	1/2	1/4	4	4	2	4	2		40	40	20	40	20
	1/2	1/2	1/4	1/2	1/2	4	4	2	4	4		40	40	20	40	40

PLL Multipli- cation Ratio	FRQCR Division Ratio Setting					Clock Ratio					Input Clock	Clock Frequency (MHz)*				
	I ϕ	B ϕ	P ϕ	MI ϕ	MP ϕ	I ϕ	B ϕ	P ϕ	MI ϕ	MP ϕ		I ϕ	B ϕ	P ϕ	MI ϕ	MP ϕ
	×8	1/2	1/2	1/2	1/2	1/2	4	4	4	4	4	10	40	40	40	40
	1/1	1/8	1/8	1/8	1/8	8	1	1	1	1		80	10	10	10	10
	1/1	1/8	1/8	1/4	1/8	8	1	1	2	1		80	10	10	20	10
	1/1	1/8	1/8	1/2	1/8	8	1	1	4	1		80	10	10	40	10
	1/1	1/8	1/8	1/1	1/8	8	1	1	8	1		80	10	10	80	10
	1/1	1/4	1/8	1/8	1/8	8	2	1	1	1		80	20	10	10	10
	1/1	1/4	1/8	1/4	1/8	8	2	1	2	1		80	20	10	20	10
	1/1	1/4	1/8	1/4	1/4	8	2	1	2	2		80	20	10	20	20
	1/1	1/4	1/8	1/2	1/8	8	2	1	4	1		80	20	10	40	10
	1/1	1/4	1/8	1/2	1/4	8	2	1	4	2		80	20	10	40	20
	1/1	1/4	1/8	1/1	1/8	8	2	1	8	1		80	20	10	80	10
	1/1	1/4	1/8	1/1	1/4	8	2	1	8	2		80	20	10	80	20
	1/1	1/4	1/4	1/4	1/4	8	2	2	2	2		80	20	20	20	20
	1/1	1/4	1/4	1/2	1/4	8	2	2	4	2		80	20	20	40	20
	1/1	1/4	1/4	1/1	1/4	8	2	2	8	2		80	20	20	80	20
	1/1	1/3	1/3	1/3	1/3	8	8/3	8/3	8/3	8/3		80	26	26	26	26
	1/1	1/3	1/3	1/1	1/3	8	8/3	8/3	8	8/3		80	26	26	80	26
	1/1	1/2	1/8	1/8	1/8	8	4	1	1	1		80	40	10	10	10
	1/1	1/2	1/8	1/4	1/8	8	4	1	2	1		80	40	10	20	10
	1/1	1/2	1/8	1/4	1/4	8	4	1	2	2		80	40	10	20	20
	1/1	1/2	1/8	1/2	1/8	8	4	1	4	1		80	40	10	40	10
	1/1	1/2	1/8	1/2	1/4	8	4	1	4	2		80	40	10	40	20
	1/1	1/2	1/8	1/2	1/2	8	4	1	4	4		80	40	10	40	40
	1/1	1/2	1/8	1/1	1/8	8	4	1	8	1		80	40	10	80	10
	1/1	1/2	1/8	1/1	1/4	8	4	1	8	2		80	40	10	80	20
	1/1	1/2	1/8	1/1	1/2	8	4	1	8	4		80	40	10	80	40
	1/1	1/2	1/4	1/4	1/4	8	4	2	2	2		80	40	20	20	20
	1/1	1/2	1/4	1/2	1/4	8	4	2	4	2		80	40	20	40	20

PLL Multipli- cation Ratio	FRQCR Division Ratio Setting					Clock Ratio					Clock Frequency (MHz)*					
	I ϕ	B ϕ	P ϕ	MI ϕ	MP ϕ	I ϕ	B ϕ	P ϕ	MI ϕ	MP ϕ	Input	I ϕ	B ϕ	P ϕ	MI ϕ	MP ϕ
											Clock					
×8	1/1	1/2	1/4	1/2	1/2	8	4	2	4	4	10	80	40	20	40	40
	1/1	1/2	1/4	1/1	1/4	8	4	2	8	2		80	40	20	80	20
	1/1	1/2	1/4	1/1	1/2	8	4	2	8	4		80	40	20	80	40
	1/1	1/2	1/2	1/2	1/2	8	4	4	4	4		80	40	40	40	40
	1/1	1/2	1/2	1/1	1/2	8	4	4	8	4		80	40	40	80	40
	1/1	1/1	1/4	1/4	1/4	8	8	2	2	2	5	40	40	10	10	10
	1/1	1/1	1/4	1/2	1/4	8	8	2	4	2		40	40	10	20	10
	1/1	1/1	1/4	1/2	1/2	8	8	2	4	4		40	40	10	20	20
	1/1	1/1	1/4	1/1	1/4	8	8	2	8	2		40	40	10	40	10
	1/1	1/1	1/4	1/1	1/2	8	8	2	8	4		40	40	10	40	20
	1/1	1/1	1/4	1/1	1/1	8	8	2	8	8		40	40	10	40	40
	1/1	1/1	1/3	1/3	1/3	8	8	8/3	8/3	8/3		40	40	13	13	13
	1/1	1/1	1/3	1/1	1/3	8	8	8/3	8	8/3		40	40	13	40	13
	1/1	1/1	1/3	1/1	1/1	8	8	8/3	8	8		40	40	13	40	40
	1/1	1/1	1/2	1/2	1/2	8	8	4	4	4		40	40	20	20	20
	1/1	1/1	1/2	1/1	1/2	8	8	4	8	4		40	40	20	40	20
	1/1	1/1	1/2	1/1	1/1	8	8	4	8	8		40	40	20	40	40
	1/1	1/1	1/1	1/1	1/1	8	8	8	8	8		40	40	40	40	40

- Notes: * Clock frequencies when the input clock frequency is assumed to be the shown value.
1. The PLL multiplication ratio is fixed at $\times 8$. The division ratio can be selected from $\times 1$, $\times 1/2$, $\times 1/3$, $\times 1/4$, and $\times 1/8$ for each clock by the setting in the frequency control register.
 2. The output frequency of the PLL circuit is the product of the frequency of the input from the crystal resonator or EXTAL pin and the multiplication ratio ($\times 8$) of the PLL circuit.
 3. The input to the divider is always the output from the PLL circuit.
 4. The internal clock ($I\phi$) frequency is the product of the frequency of the input from the crystal resonator or EXTAL pin, the multiplication ratio ($\times 8$) of the PLL circuit, and the division ratio of the divider. The resultant frequency must be a maximum of 80 MHz (maximum operating frequency).
 5. The bus clock ($B\phi$) frequency is the product of the frequency of the input from the crystal resonator or EXTAL pin, the multiplication ratio ($\times 8$) of the PLL circuit, and the division ratio of the divider. The resultant frequency must be a maximum of 40 MHz and equal to or lower than the internal clock ($I\phi$) frequency.
 6. The peripheral clock ($P\phi$) frequency is the product of the frequency of the input from the crystal resonator or EXTAL pin, the multiplication ratio ($\times 8$) of the PLL circuit, and the division ratio of the divider. The resultant frequency must be a maximum of 40 MHz and equal to or lower than the bus clock ($B\phi$) frequency.
 7. When using the MTU2S and MTU2, the MTU2S clock ($MI\phi$) frequency must be equal to or lower than the internal clock ($I\phi$) frequency and equal to or higher than the MTU2 clock ($MP\phi$) frequency. The MTU2 clock ($MP\phi$) frequency must be equal to or lower than the MTU2S clock ($MI\phi$) frequency and the bus clock ($B\phi$) frequency, and equal to or higher than the peripheral clock frequency ($P\phi$). The MTU2S clock ($MI\phi$) frequency and MTU2 clock ($MP\phi$) frequency are the product of the frequency of the input from the crystal resonator or EXTAL pin, the multiplication ratio ($\times 8$) of the PLL circuit, and the division ratio of the divider.
 8. The frequency of the CK pin is always be equal to the bus clock ($B\phi$) frequency.

4.4 Register Descriptions

The CPG has the following registers.

For details on the addresses of these registers and the states of these registers in each processing state, see section 23, List of Registers.

Table 4.5 Register Configuration

Register Name	Abbreviation	R/W	Initial Value	Address	Access Size
Frequency control register	FRQCR	R/W	H'36DB	H'FFFE800	16
Oscillation stop detection control register	OSCCR	R/W	H'00	H'FFFE814	8

4.4.1 Frequency Control Register (FRQCR)

FRQCR is a 16-bit readable/writable register that specifies the frequency division ratios for the internal clock ($I\phi$), bus clock ($B\phi$), peripheral clock ($P\phi$), MTU2S clock ($MI\phi$), and MTU2 clock ($MP\phi$). FRQCR can be accessed only in words.

FRQCR is initialized to H'36DB only by a power-on reset (except a power-on reset due to a WDT overflow).

Bit:	15	14	13	12	11	10	9	8	7	6	5	4	3	2	1	0
	-	IFC[2:0]			BFC[2:0]			PFC[2:0]			MIFC[2:0]			MPFC[2:0]		
Initial value:	0	0	1	1	0	1	1	0	1	1	0	1	1	0	1	1
R/W:	R	R/W	R/W	R/W	R/W	R/W	R/W	R/W	R/W	R/W	R/W	R/W	R/W	R/W	R/W	R/W

Bit	Bit Name	Initial Value	R/W	Description
15	—	0	R	Reserved This bit is always read as 0. The write value should always be 0.
14 to 12	IFC[2:0]	011	R/W	Internal Clock (I ϕ) Frequency Division Ratio Specify the division ratio of the internal clock (I ϕ) frequency with respect to the output frequency of PLL circuit. If a prohibited value is specified, subsequent operation is not guaranteed. 000: $\times 1$ 001: $\times 1/2$ 010: $\times 1/3$ 011: $\times 1/4$ 100: $\times 1/8$ Other than above: Setting prohibited
11 to 9	BFC[2:0]	011	R/W	Bus Clock (B ϕ) Frequency Division Ratio Specify the division ratio of the bus clock (B ϕ) frequency with respect to the output frequency of PLL circuit. If a prohibited value is specified, subsequent operation is not guaranteed. 000: $\times 1$ 001: $\times 1/2$ 010: $\times 1/3$ 011: $\times 1/4$ 100: $\times 1/8$ Other than above: Setting prohibited

Bit	Bit Name	Initial Value	R/W	Description
8 to 6	PFC[2:0]	011	R/W	<p>Peripheral Clock ($P\phi$) Frequency Division Ratio</p> <p>Specify the division ratio of the peripheral clock ($P\phi$) frequency with respect to the output frequency of PLL circuit. If a prohibited value is specified, subsequent operation is not guaranteed.</p> <p>000: $\times 1$ 001: $\times 1/2$ 010: $\times 1/3$ 011: $\times 1/4$ 100: $\times 1/8$ Other than above: Setting prohibited</p>
5 to 3	MIFC[2:0]	011	R/W	<p>MTU2S Clock ($MI\phi$) Frequency Division Ratio</p> <p>Specify the division ratio of the MTU2S clock ($MI\phi$) frequency with respect to the output frequency of PLL circuit. If a prohibited value is specified, subsequent operation is not guaranteed.</p> <p>000: $\times 1$ 001: $\times 1/2$ 010: $\times 1/3$ 011: $\times 1/4$ 100: $\times 1/8$ Other than above: Setting prohibited</p>
2 to 0	MPFC[2:0]	011	R/W	<p>MTU2 Clock ($MP\phi$) Frequency Division Ratio</p> <p>Specify the division ratio of the MTU2 clock ($MP\phi$) frequency with respect to the output frequency of PLL circuit. If a prohibited value is specified, subsequent operation is not guaranteed.</p> <p>000: $\times 1$ 001: $\times 1/2$ 010: $\times 1/3$ 011: $\times 1/4$ 100: $\times 1/8$ Other than above: Setting prohibited</p>

4.4.2 Oscillation Stop Detection Control Register (OSCCR)

OSCCR is an 8-bit readable/writable register that has an oscillation stop detection flag and selects flag status output to an external pin. OSCCR can be accessed only in bytes.

Bit:	7	6	5	4	3	2	1	0
	-	-	-	-	-	OSC STOP	-	OSC ERS
Initial value:	0	0	0	0	0	0	0	0
R/W:	R	R	R	R	R	R	R	R/W

Bit	Bit Name	Initial Value	R/W	Description
7 to 3	—	All 0	R	Reserved These bits are always read as 0. The write value should always be 0.
2	OSCSTOP	0	R	Oscillation Stop Detection Flag [Setting conditions] <ul style="list-style-type: none"> When a stop in the clock input is detected during normal operation When software standby mode is entered [Clearing conditions] <ul style="list-style-type: none"> By a power-on reset input through the $\overline{\text{RES}}$ pin When software standby mode is canceled
1	—	0	R	Reserved This bit is always read as 0. The write value should always be 0.
0	OSCERS	0	R/W	Oscillation Stop Detection Flag Output Select Selects whether to output the oscillation stop detection flag signal through the WDTOVF pin. 0: Outputs only the WDT overflow signal through the WDTOVF pin 1: Outputs the WDT overflow signal and the oscillation stop detection flag signal through the WDTOVF pin

4.5 Changing Frequency

Selecting division ratios for the frequency divider can change the frequencies of the internal clock ($I\phi$), bus clock ($B\phi$), peripheral clock ($P\phi$), MTU2S clock ($MI\phi$), and MTU2 clock ($MP\phi$). This is controlled by software through the frequency control register (FRQCR). The following describes how to specify the frequencies.

1. In the initial state, $IFC2$ to $IFC0 = H'011$ ($\times 1/4$), $BFC2$ to $BFC0 = H'011$ ($\times 1/4$), $PFC2$ to $PFC0 = H'011$ ($\times 1/4$), $MIFC2$ to $MIFC0 = H'011$ ($\times 1/4$), and $MPFC2$ to $MPFC0 = H'011$ ($\times 1/4$).
2. Stop all modules except the CPU, on-chip ROM, and on-chip RAM.
3. Set the desired values in bits $IFC2$ to $IFC0$, $BFC2$ to $BFC0$, $PFC2$ to $PFC0$, $MIFC2$ to $MIFC0$, and $MPFC2$ to $MPFC0$ bits. Since the frequency multiplication ratio in the PLL circuit is fixed at $\times 8$, the frequencies are determined only by selecting division ratios. When specifying the frequencies, satisfy the following condition: internal clock ($I\phi$) \geq bus clock ($B\phi$) \geq peripheral clock ($P\phi$). When using the MTU2S clock and MTU2 clock, specify the frequencies to satisfy the following condition: internal clock ($I\phi$) \geq MTU2S clock ($MI\phi$) \geq MTU2 clock ($MP\phi$) \geq peripheral clock ($P\phi$) and bus clock ($B\phi$) \geq MTU2 clock ($MP\phi$). Code to rewrite values of FRQCR should be executed in the on-chip ROM or on-chip RAM.
4. After an instruction to rewrite FRQCR has been issued, the actual clock frequencies will change after $(1 \text{ to } 24n) \text{ cyc} + 11B\phi + 7P\phi$.
 n: Division ratio specified by the BFC bit in FRQCR (1, 1/2, 1/3, 1/4, or 1/8)
 cyc: Clock obtained by dividing EXTAL by 8 with the PLL.

Note: (1 to 24n) depends on the internal state.

4.6 Oscillator

Clock pulses can be supplied from a connected crystal resonator or an external clock.

4.6.1 Connecting Crystal Resonator

A crystal resonator can be connected as shown in figure 4.2. Use the damping resistance (R_d) listed in table 4.6. Use a crystal resonator that has a resonance frequency of 5 to 12.5 MHz. It is recommended to consult the crystal resonator manufacturer concerning the compatibility of the crystal resonator and the LSI.

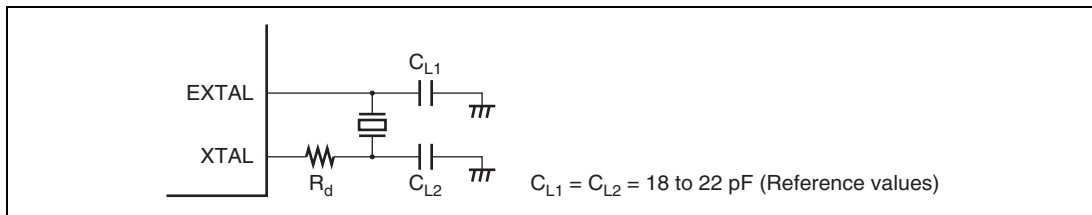

Figure 4.2 Connection of Crystal Resonator (Example)

Table 4.6 Damping Resistance Values (Reference Values)

Frequency (MHz)	5	8	10	12.5
R_d (Ω) (Reference values)	500	200	0	0

Figure 4.3 shows an equivalent circuit of the crystal resonator. Use a crystal resonator with the characteristics listed in table 4.7.

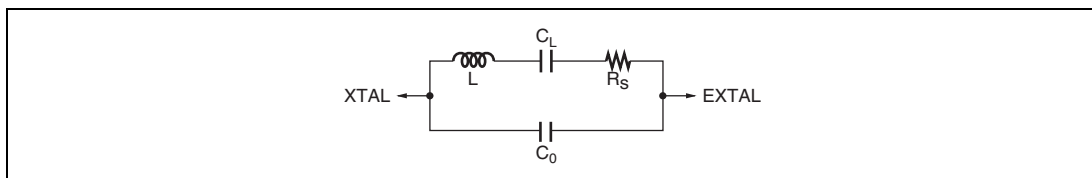

Figure 4.3 Crystal Resonator Equivalent Circuit

Table 4.7 Crystal Resonator Characteristics

Frequency (MHz)	5	8	10	12.5
Rs Max. (Ω) (Reference values)	120	80	60	50
Co Max. (pF) (Reference values)	7	7	7	7

4.6.2 External Clock Input Method

Figure 4.4 shows an example of an external clock input connection. In this case, make the external clock high level to stop it when in software standby mode. During operation, make the external input clock frequency 5 to 12.5 MHz.

When leaving the XTAL pin open, make sure the parasitic capacitance is less than 10 pF.

Even when inputting an external clock, be sure to wait at least the oscillation stabilization time in power-on sequence or in releasing software standby mode, in order to ensure the PLL stabilization time.

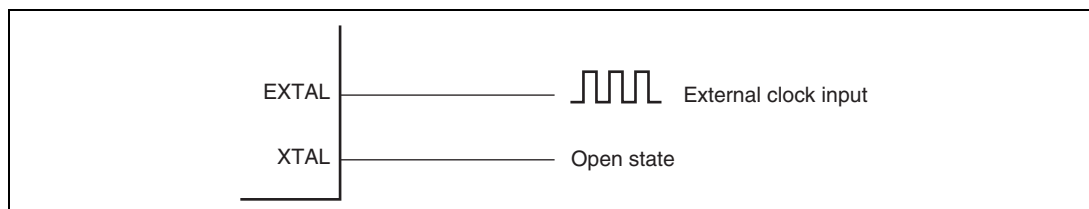

Figure 4.4 Example of External Clock Connection

4.7 Function for Detecting Oscillator Stop

This CPG detects a stop in the clock input if any system abnormality halts the clock supply.

When no change has been detected in the EXTAL input for a certain period, the OSCSTOP bit in OSCCR is set to 1 and this state is retained until a power-on reset is input through the $\overline{\text{RES}}$ pin or software standby mode is canceled. If the OSCERS bit is set to 1 at this time, an oscillation stop detection flag signal is output through the $\overline{\text{WDTOVF}}$ pin. In addition, the high-current ports (pins to which the TIOC3B, TIOC3D, and TIOC4A to TIOC4D signals in the MTU2 and the TIOC3BS, TIOC3DS, and TIOC4AS to TIOC4DS signals in the MTU2S are assigned) can be placed in high-impedance state regardless of the PFC setting. For details, refer to appendix A, Pin States.

Even in software standby mode, these pins can be placed in high-impedance state. For details, refer to appendix A, Pin States. These pins enter the normal state after software standby mode is canceled. Under an abnormal condition where oscillation stops while the LSI is not in software standby mode, LSI operations other than the oscillation stop detection function become unpredictable. In this case, even after oscillation is restarted, LSI operations including the above high-current pins become unpredictable.

Even while no change is detected in the EXTAL input, the PLL circuit in this LSI continues oscillating at a frequency range from 100 kHz to 10 MHz (depending on the temperature and operating voltage).

4.8 Usage Notes

4.8.1 Note on Crystal Resonator

A sufficient evaluation at the user's site is necessary to use the LSI, by referring the resonator connection examples shown in this section, because various characteristics related to the crystal resonator are closely linked to the user's board design. As the oscillator circuit's circuit constant will depend on the resonator and the floating capacitance of the mounting circuit, the value of each external circuit's component should be determined in consultation with the resonator manufacturer. The design must ensure that a voltage exceeding the maximum rating is not applied to the oscillator pin.

4.8.2 Notes on Board Design

Measures against radiation noise are taken in this LSI. If further reduction in radiation noise is needed, it is recommended to use a multiple layer board and provide a layer exclusive to the system ground.

When using a crystal resonator, place the crystal resonator and its load capacitors as close as possible to the XTAL and EXTAL pins. Do not route any signal lines near the oscillator circuitry as shown in figure 4.5. Otherwise, correct oscillation can be interfered by induction.

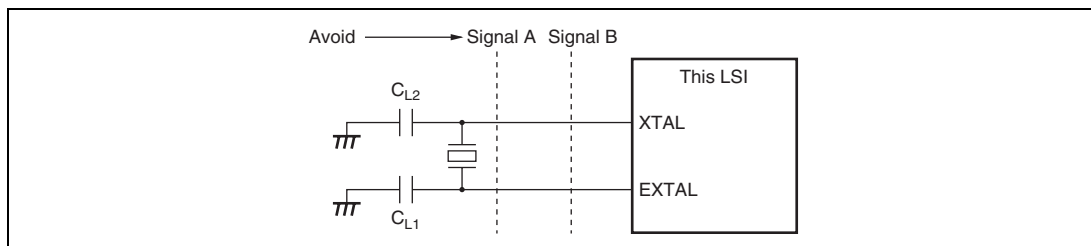

Figure 4.5 Cautions for Oscillator Circuit Board Design

A circuitry shown in figure 4.6 is recommended as an external circuitry around the PLL. Separate the PLL power lines (PLL V_{SS}) and the system power lines (V_{CC} , V_{SS}) at the board power supply source, and be sure to insert bypass capacitors CB and CPB close to the pins.

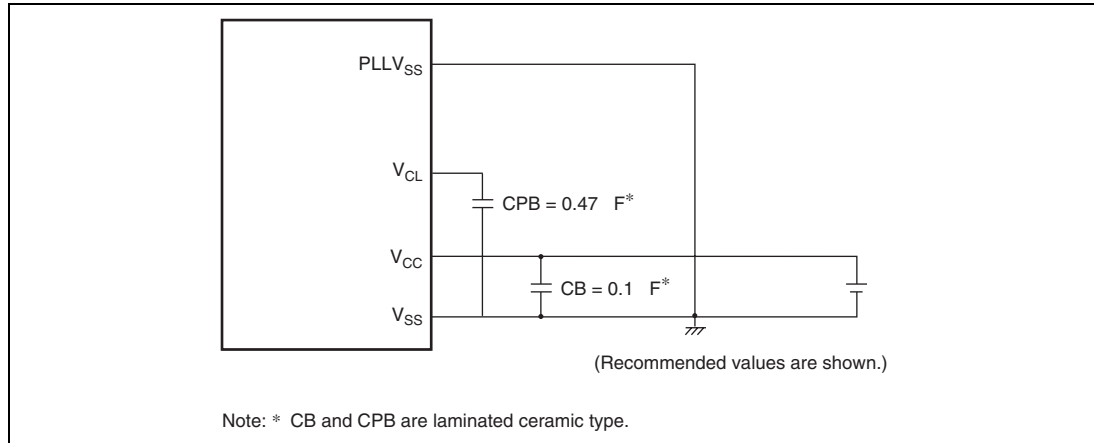

Figure 4.6 Recommended External Circuitry around PLL

Section 5 Exception Handling

5.1 Overview

5.1.1 Types of Exception Handling and Priority

Exception handling is started by four sources: resets, address errors, interrupts and instructions and have the priority, as shown in table 5.1. When several exceptions are detected at once, they are processed according to the priority.

Table 5.1 Types of Exceptions and Priority

Exception	Exception Source	Priority
Reset	Power-on reset	
	Manual reset	
Interrupt	User break (break before instruction execution)	
Address error	CPU address error (instruction fetch)	
Instruction	General illegal instructions (undefined code)	
	Illegal slot instruction (undefined code placed immediately after a delayed branch instruction* ¹ or instruction that changes the PC value* ²)	
	Trap instruction (TRAPA instruction)	
Address error	CPU address error (data access)	
Interrupt	User break (break after instruction execution or operand break)	
Address error	DTC address error (data access)	
Interrupt	NMI	
	IRQ	
	On-chip peripheral modules	

Notes: 1. Delayed branch instructions: JMP, JSR, BRA, BSR, RTS, RTE, BF/S, BT/S, BSRF, and BRAF.

2. Instructions that change the PC value: JMP, JSR, BRA, BSR, RTS, RTE, BT, BF, TRAPA, BF/S, BT/S, BSRF, BRAF, LDC Rm,SR, LDC.L @Rm+,SR.

5.1.2 Exception Handling Operations

The exceptions are detected and the exception handling starts according to the timing shown in table 5.2.

Table 5.2 Timing for Exception Detection and Start of Exception Handling

Exception		Timing of Source Detection and Start of Exception Handling
Reset	Power-on reset	Started when the $\overline{\text{RES}}$ pin changes from low to high or when the WDT overflows.
	Manual reset	Started when the $\overline{\text{MRES}}$ pin changes from low to high or when the WDT overflows.
Address error Interrupt		Detected during the instruction decode stage and started after the execution of the current instruction is completed.
Instruction	Trap instruction	Started by the execution of the TRAPA instruction.
	General illegal instructions	Started when an undefined code placed at other than a delay slot (immediately after a delayed branch instruction) is decoded.
	Illegal slot instructions	Started when an undefined code placed at a delay slot (immediately after a delayed branch instruction) or an instruction that changes the PC value is detected.

When exception handling starts, the CPU operates

Exception Handling Triggered by Reset: The initial values of the program counter (PC) and stack pointer (SP) are fetched from the exception handling vector table (PC from the address H'00000000 and SP from the address H'00000004 when a power-on reset. PC from the address H'00000008 and SP from the address H'0000000C when a manual reset.). For details, see section 5.1.3, Exception Handling Vector Table. H'00000000 is then written to the vector base register (VBR), and H'F (B'1111) is written to the interrupt mask bits (I3 to I0) in the status register (SR). The program starts from the PC address fetched from the exception handling vector table.

Exception Handling Triggered by Address Error, Interrupt, and Instruction: SR and PC are saved to the stack indicated by R15. For interrupt exception handling, the interrupt priority level is written to the interrupt mask bits (I3 to I0) in SR. For address error and instruction exception handling, bits I3 to I0 are not affected. The start address is then fetched from the exception handling vector table and the program starts from that address.

5.1.3 Exception Handling Vector Table

Before exception handling starts, the exception handling vector table must be set in memory. The exception handling vector table stores the start addresses of exception handling routines. (The reset exception handling table holds the initial values of PC and SP.)

All exception sources are given different vector numbers and vector table address offsets. The vector table addresses are calculated from these vector numbers and vector table address offsets. During exception handling, the start addresses of the exception handling routines are fetched from the exception handling vector table that is indicated by this vector table address.

Table 5.3 shows the vector numbers and vector table address offsets. Table 5.4 shows how vector table addresses are calculated.

Table 5.3 Vector Numbers and Vector Table Address Offsets

Exception Handling Source		Vector Number	Vector Table Address Offset
Power-on reset	PC	0	H'00000000 to H'00000003
	SP	1	H'00000004 to H'00000007
Manual reset	PC	2	H'00000008 to H'0000000B
	SP	3	H'0000000C to H'0000000F
General illegal instruction		4	H'00000010 to H'00000013
(Reserved for system use)		5	H'00000014 to H'00000017
Illegal slot instruction		6	H'00000018 to H'0000001B
(Reserved for system use)		7	H'0000001C to H'0000001F
		8	H'00000020 to H'00000023
CPU address error		9	H'00000024 to H'00000027
DTC address error		10	H'00000028 to H'0000002B
Interrupt	NMI	11	H'0000002C to H'0000002F
	User break	12	H'00000030 to H'00000033
(Reserved for system use)		13	H'00000034 to H'00000037
		:	:
		31	H'0000007C to H'0000007F
Trap instruction (user vector)		32	H'00000080 to H'00000083
		:	:
		63	H'000000FC to H'000000FF

Exception Handling Source		Vector Number	Vector Table Address Offset
Interrupt	IRQ0	64	H'00000100 to H'00000103
	IRQ1	65	H'00000104 to H'00000107
	IRQ2	66	H'00000108 to H'0000010B
	IRQ3	67	H'0000010C to H'0000010F
(Reserved for system use)		68	H'00000110 to H'00000113
		69	H'00000114 to H'00000117
		70	H'00000118 to H'0000011B
		71	H'0000011C to H'0000011F
On-chip peripheral module*		72	H'00000120 to H'00000123
		:	:
		255	H'000003FC to H'000003FF

Note: * For details on the vector numbers and vector table address offsets of on-chip peripheral module interrupts, see table 6.3.

Table 5.4 Calculating Exception Handling Vector Table Addresses

Exception Source	Vector Table Address Calculation
Resets	Vector table address = (vector table address offset) = (vector number) × 4
Address errors, interrupts, instructions	Vector table address = VBR + (vector table address offset) = VBR + (vector number) × 4

Notes: 1. VBR: Vector base register
2. Vector table address offset: See table 5.3.
3. Vector number: See table 5.3.

5.2 Resets

5.2.1 Types of Resets

Resets have priority over any exception source. There are two types of resets: power-on resets and manual resets. As table 5.5 shows, both types of resets initialize the internal status of the CPU. In power-on resets, all registers of the on-chip peripheral modules are initialized; in manual resets, they are not.

Table 5.5 Reset Status

Type	Conditions for Transition to Reset State			Internal State		
	$\overline{\text{RES}}$	WDT Overflow	$\overline{\text{MRES}}$	CPU, INTC	On-Chip Peripheral Module	POE, PFC, I/O Port
Power-on reset	Low	—	—	Initialized	Initialized	Initialized
	High	Overflow	High	Initialized	Initialized	Initialized
Manual reset	High	Not overflowed	Low	Initialized	Not initialized	Not initialized

5.2.2 Power-On Reset

Power-On Reset by $\overline{\text{RES}}$ Pin: When the $\overline{\text{RES}}$ pin is driven low, this LSI enters the power-on reset state. To reliably reset this LSI, the $\overline{\text{RES}}$ pin should be kept low for at least the oscillation settling time when applying the power or when in standby mode (when the clock is halted) or at least 20 tcyc when the clock is operating. During the power-on reset state, CPU internal states and all registers of on-chip peripheral modules are initialized. See appendix A, Pin States, for the status of individual pins during power-on reset mode.

In the power-on reset state, power-on reset exception handling starts when driving the $\overline{\text{RES}}$ pin high after driving the pin low for the given time. The CPU operates as follows:

1. The initial value (execution start address) of the program counter (PC) is fetched from the exception handling vector table.
2. The initial value of the stack pointer (SP) is fetched from the exception handling vector table.
3. The vector base register (VBR) is cleared to H'00000000 and the interrupt mask bits (I3 to I0) of the status register (SR) are set to H'F (B'1111).
4. The values fetched from the exception handling vector table are set in PC and SP, then the program starts.

Be certain to always perform power-on reset exception handling when turning the system power on.

Power-On Reset by WDT: When WTCNT of the WDT overflows while a setting is made so that a power-on reset can be generated in watchdog timer mode of the WDT, this LSI enters the power-on reset state.

The frequency control register (FRQCR) in the clock pulse generator (CPG) and the watchdog timer (WDT) registers are not initialized by the reset signal generated by the WDT (these registers are only initialized by a power-on reset from the $\overline{\text{RES}}$ pin).

If a reset caused by the signal input on the $\overline{\text{RES}}$ pin and a reset caused by a WDT overflow occur simultaneously, the $\overline{\text{RES}}$ pin reset has priority, and the WOVF bit in WTCSR is cleared to 0. When the power-on reset exception handling caused by the WDT is started, the CPU operates as follows:

1. The initial value (execution start address) of the program counter (PC) is fetched from the exception handling vector table.
2. The initial value of the stack pointer (SP) is fetched from the exception handling vector table.
3. The vector base register (VBR) is cleared to H'00000000 and the interrupt mask bits (I3 to I0) of the status register (SR) are set to H'F (B'1111).
4. The values fetched from the exception handling vector table are set in the PC and SP, then the program starts.

5.2.3 Manual Reset

When the $\overline{\text{RES}}$ pin is high and the $\overline{\text{MRES}}$ pin is driven low, the LSI becomes to be a manual reset state. To reliably reset the LSI, the $\overline{\text{MRES}}$ pin should be kept at low for at least the duration of the oscillation settling time that is set in WDT when in software standby mode (when the clock is halted) or at least $20 t_{\text{cyc}}$ when the clock is operating. During manual reset, the CPU internal status is initialized. Registers of on-chip peripheral modules are not initialized. When the LSI enters manual reset status in the middle of a bus cycle, manual reset exception processing does not start until the bus cycle has ended. Thus, manual resets do not abort bus cycles. However, once $\overline{\text{MRES}}$ is driven low, hold the low level until the CPU becomes to be a manual reset mode after the bus cycle ends. (Keep at low level for at least the longest bus cycle). See appendix A, Pin States, for the status of individual pins during manual reset mode.

In the manual reset status, manual reset exception processing starts when the $\overline{\text{MRES}}$ pin is first kept low for a set period of time and then returned to high. The CPU will then operate in the same procedures as described for power-on resets.

5.3 Address Errors

5.3.1 Address Error Sources

Address errors occur when instructions are fetched or data is read from or written to, as shown in table 5.6.

Table 5.6 Bus Cycles and Address Errors

Bus Cycle			
Type	Bus Master	Bus Cycle Description	Address Errors
Instruction fetch	CPU	Instruction fetched from even address	None (normal)
		Instruction fetched from odd address	Address error occurs
		Instruction fetched from a space other than on-chip peripheral module space	None (normal)
		Instruction fetched from on-chip peripheral module space	Address error occurs
		Instruction fetched from external memory space in single chip mode	Address error occurs
Data read/write	CPU or DTC	Word data accessed from even address	None (normal)
		Word data accessed from odd address	Address error occurs
		Longword data accessed from a longword boundary	None (normal)
		Longword data accessed from other than a long-word boundary	Address error occurs
		Byte or word data accessed in on-chip peripheral module space	None (normal)
		Longword data accessed in 16-bit on-chip peripheral module space	None (normal)
		Longword data accessed in 8-bit on-chip peripheral module space	None (normal)
		External memory space accessed when in single chip mode	Address error occurs

5.3.2 Address Error Exception Source

When an address error exception is generated, the bus cycle which caused the address error ends, the current instruction finishes, and then the address error exception handling starts. The CPU operates as follows:

1. The status register (SR) is saved to the stack.
2. The program counter (PC) is saved to the stack. The PC value to be saved is the start address of the instruction which caused an address error exception. When the instruction that caused the exception is placed in the delay slot, the address of the delayed branch instruction which is placed immediately before the delay slot.
3. The start address of the exception handling routine is fetched from the exception handling vector table that corresponds to the generated address error, and the program starts executing from that address. This branch is not a delayed branch.

5.4 Interrupts

5.4.1 Interrupt Sources

Table 5.7 shows the sources that start the interrupt exception handling. They are NMI, user break, IRQ, and on-chip peripheral modules.

Table 5.7 Interrupt Sources

Type	Request Source	Number of Sources
NMI	NMI pin (external input)	1
User break	User break controller (UBC)	1
IRQ	IRQ0 to IRQ3 pins (external input)	4
On-chip peripheral module	Multi-function timer pulse unit 2 (MTU2)	28
	Multi-function timer pulse unit 2S (MTU2S)	13
	Data transfer controller (DTC)	1
	Watchdog timer (WDT)	1
	A/D converter (A/D_0, A/D_1, and A/D_2)	3
	Compare match timer (CMT_0 and CMT_1)	2
	Serial communication interface (SCI_0, SCI_1, and SCI_2)	12
	Port output enable (POE)	3

All interrupt sources are given different vector numbers and vector table address offsets. For details on vector numbers and vector table address offsets, see table 6.3.

5.4.2 Interrupt Priority

The interrupt priority is predetermined. When multiple interrupts occur simultaneously (overlapped interruptions), the interrupt controller (INTC) determines their relative priorities and starts the exception handling according to the results.

The priority of interrupts is expressed as priority levels 0 to 16, with priority 0 the lowest and priority 16 the highest. The NMI interrupt has priority 16 and cannot be masked, so it is always accepted. The priority level of the user break interrupt is 15. IRQ interrupt and on-chip peripheral module interrupt priority levels can be set freely using the interrupt priority registers A, D to F, and H to L (IPRA, IPRD to IPRF, and IPRH to IPRL) of the INTC as shown in table 5.8. The priority levels that can be set are 0 to 15. Level 16 cannot be set. For details on IPRA, IPRD to IPRF, and IPRH to IPRL, see section 6.3.4, Interrupt Priority Registers A, D to F, and H to L (IPRA, IPRD to IPRF, and IPRH to IPRL).

Table 5.8 Interrupt Priority

Type	Priority Level	Comment
NMI	16	Fixed priority level. Cannot be masked.
User break	15	Fixed priority level. Can be masked.
IRQ	0 to 15	Set with interrupt priority registers A, D to F, and H to L (IPRA, IPRD to IPRF, and IPRH to IPRL).
On-chip peripheral module		

5.4.3 Interrupt Exception Handling

When an interrupt occurs, the interrupt controller (INTC) ascertains its priority level. NMI is always accepted, but other interrupts are only accepted if they have a priority level higher than the priority level set in the interrupt mask bits (I3 to I0) of the status register (SR).

When an interrupt is accepted, exception handling begins. In interrupt exception handling, the CPU saves SR and the program counter (PC) to the stack. The priority level of the accepted interrupt is written to bits I3 to I0 in SR. Although the priority level of the NMI is 16, the value set in bits I3 to I0 is H'F (level 15). Next, the start address of the exception handling routine is fetched from the exception handling vector table for the accepted interrupt, and program execution branches to that address and the program starts. For details on the interrupt exception handling, see section 6.6, Interrupt Operation.

5.5 Exceptions Triggered by Instructions

5.5.1 Types of Exceptions Triggered by Instructions

Exception handling can be triggered by the trap instruction, illegal slot instructions, and general illegal instructions, as shown in table 5.9.

Table 5.9 Types of Exceptions Triggered by Instructions

Type	Source Instruction	Comment
Trap instruction	TRAPA	—
Illegal slot instructions*	Undefined code placed immediately after a delayed branch instruction (delay slot) or instructions that changes the PC value	Delayed branch instructions: JMP, JSR, BRA, BSR, RTS, RTE, BF/S, BT/S, BSRF, BRAF Instructions that changes the PC value: JMP, JSR, BRA, BSR, RTS, RTE, BT, BF, TRAPA, BF/S, BT/S, BSRF, BRAF, LDC Rm,SR, LDC.L @Rm+,SR
General illegal instructions*	Undefined code anywhere besides in a delay slot	—

Note: * The operation is not guaranteed when undefined instructions other than H'F000 to H'FFFF are decoded.

5.5.2 Trap Instructions

When a TRAPA instruction is executed, the trap instruction exception handling starts. The CPU operates as follows:

1. The status register (SR) is saved to the stack.
2. The program counter (PC) is saved to the stack. The PC value saved is the start address of the instruction to be executed after the TRAPA instruction.
3. The CPU reads the start address of the exception handling routine from the exception handling vector table that corresponds to the vector number specified in the TRAPA instruction, program execution branches to that address, and then the program starts. This branch is not a delayed branch.

5.5.3 Illegal Slot Instructions

An instruction placed immediately after a delayed branch instruction is called "instruction placed in a delay slot". When the instruction placed in the delay slot is an undefined code, illegal slot exception handling starts after the undefined code is decoded. Illegal slot exception handling also starts when an instruction that changes the program counter (PC) value is placed in a delay slot and the instruction is decoded. The CPU handles an illegal slot instruction as follows:

1. The status register (SR) is saved to the stack.
2. The program counter (PC) is saved to the stack. The PC value saved is the target address of the delayed branch instruction immediately before the undefined code or the instruction that rewrites the PC.
3. The start address of the exception handling routine is fetched from the exception handling vector table that corresponds to the exception that occurred. Program execution branches to that address and the program starts. This branch is not a delayed branch.

5.5.4 General Illegal Instructions

When an undefined code placed anywhere other than immediately after a delayed branch instruction (i.e., in a delay slot) is decoded, general illegal instruction exception handling starts. The CPU handles the general illegal instructions in the same procedures as in the illegal slot instructions. Unlike processing of illegal slot instructions, however, the program counter value that is stacked is the start address of the undefined code.

5.6 Cases when Exceptions Are Accepted

When an exception other than resets occurs during decoding the instruction placed in a delay slot or immediately after an interrupt disabled instruction, it may not be accepted and be held shown in table 5.10. In this case, when an instruction which accepts an interrupt request is decoded, the exception is accepted.

Table 5.10 Delay Slot Instructions, Interrupt Disabled Instructions, and Exceptions

Occurrence Timing	Exception				
	Address Error	General Illegal Instruction	Slot Illegal Instruction	Trap Instruction	Interrupt
Instruction in delay slot	x* ²	—	x* ²	—	x* ³
Immediately after interrupt disabled instruction* ¹	√	√	√	√	x* ⁴

[Legend]

- √: Accepted
- x: Not accepted
- : Does not occur

- Notes:
1. Interrupt disabled instructions: LDC, LDC.L, STC, STC.L, LDS, LDS.L, STS, and STS.L
 2. An exception is accepted before the execution of a delayed branch instruction. However, when an address error or a slot illegal instruction exception occurs in the delay slot of the RTE instruction, correct operation is not guaranteed.
 3. An exception is accepted after a delayed branch (between instructions in the delay slot and the branch destination).
 4. An exception is accepted after the execution of the next instruction of an interrupt disabled instruction (before the execution two instructions after an interrupt disabled instruction).

5.7 Stack States after Exception Handling Ends

The stack states after exception handling ends are shown in table 5.11.

Table 5.11 Stack Status after Exception Handling Ends

Types	Stack State				
Address error (when the instruction that caused an exception is placed in the delay slot)	<p>SP →</p> <table border="1"> <tr> <td>Address of delayed branch instruction</td> <td>32 bits</td> </tr> <tr> <td>SR</td> <td>32 bits</td> </tr> </table>	Address of delayed branch instruction	32 bits	SR	32 bits
Address of delayed branch instruction	32 bits				
SR	32 bits				
Address error (other than above)	<p>SP →</p> <table border="1"> <tr> <td>Address of instruction that caused exception</td> <td>32 bits</td> </tr> <tr> <td>SR</td> <td>32 bits</td> </tr> </table>	Address of instruction that caused exception	32 bits	SR	32 bits
Address of instruction that caused exception	32 bits				
SR	32 bits				
Interrupt	<p>SP →</p> <table border="1"> <tr> <td>Address of instruction after executed instruction</td> <td>32 bits</td> </tr> <tr> <td>SR</td> <td>32 bits</td> </tr> </table>	Address of instruction after executed instruction	32 bits	SR	32 bits
Address of instruction after executed instruction	32 bits				
SR	32 bits				
Trap instruction	<p>SP →</p> <table border="1"> <tr> <td>Address of instruction after TRAPA instruction</td> <td>32 bits</td> </tr> <tr> <td>SR</td> <td>32 bits</td> </tr> </table>	Address of instruction after TRAPA instruction	32 bits	SR	32 bits
Address of instruction after TRAPA instruction	32 bits				
SR	32 bits				

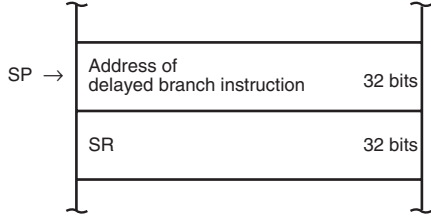
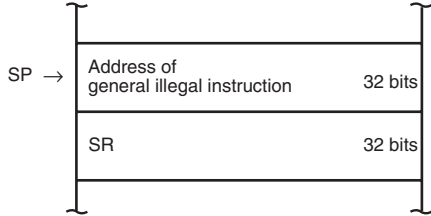
Types	Stack State
Illegal slot instruction	 <p>The diagram shows a stack structure with two 32-bit fields. The top field is labeled 'Address of delayed branch instruction' and the bottom field is labeled 'SR'. A pointer 'SP' points to the top of the stack, which is aligned with the top of the 'Address of delayed branch instruction' field.</p>
General illegal instruction	 <p>The diagram shows a stack structure with two 32-bit fields. The top field is labeled 'Address of general illegal instruction' and the bottom field is labeled 'SR'. A pointer 'SP' points to the top of the stack, which is aligned with the top of the 'Address of general illegal instruction' field.</p>

5.8 Usage Notes

5.8.1 Value of Stack Pointer (SP)

The SP value must always be a multiple of 4. If it is not, an address error will occur when the stack is accessed during exception handling.

5.8.2 Value of Vector Base Register (VBR)

The VBR value must always be a multiple of 4. If it is not, an address error will occur when the stack is accessed during exception handling.

5.8.3 Address Errors Caused by Stacking for Address Error Exception Handling

When the SP value is not a multiple of 4, an address error will occur when stacking for exception handling (interrupts, etc.) and address error exception handling will start after the first exception handling is ended. Address errors will also occur in the stacking for this address error exception handling. To ensure that address error exception handling does not go into an endless loop, no address errors are accepted at that point. This allows program control to be passed to the handling routine for address error exception and enables error processing.

When an address error occurs during exception handling stacking, the stacking bus cycle (write) is executed. When stacking the SR and PC values, the SP values for both are subtracted by 4, therefore, the SP value is still not a multiple of 4 after the stacking. The address value output during stacking is the SP value whose lower two bits are cleared to 0. So the write data stacked is undefined.

5.8.4 Notes on Slot Illegal Instruction Exception Handling

Some specifications on slot illegal instruction exception handling in this LSI differ from those of the conventional SH-2.

- Conventional SH-2: Instructions LDC Rm,SR and LDC.L @Rm+,SR are not subject to the slot illegal instructions.
- This LSI: Instructions LDC Rm,SR and LDC.L @Rm+,SR are subject to the slot illegal instructions.

The supporting status on our software products regarding this note is as follows:

Compiler

This instruction is not allocated in the delay slot in the compiler V.4 and its subsequent versions.

Real-time OS for μ ITRON specifications

1. HI7000/4, HI-SH7

This instruction does not exist in the delay slot within the OS.

2. HI7000

This instruction is in part allocated to the delay slot within the OS, which may cause the slot illegal instruction exception handling in this LSI.

3. Others

The slot illegal instruction exception handling may be generated in this LSI in a case where the instruction is described in assembler or when the middleware of the object is introduced.

Section 6 Interrupt Controller (INTC)

The interrupt controller (INTC) ascertains the priority of interrupt sources and controls interrupt requests to the CPU.

6.1 Features

- 16 levels of interrupt priority
- NMI noise canceller function
- Occurrence of interrupt can be reported externally ($\overline{\text{IRQOUT}}$ pin)

Figure 6.1 shows a block diagram of the INTC.

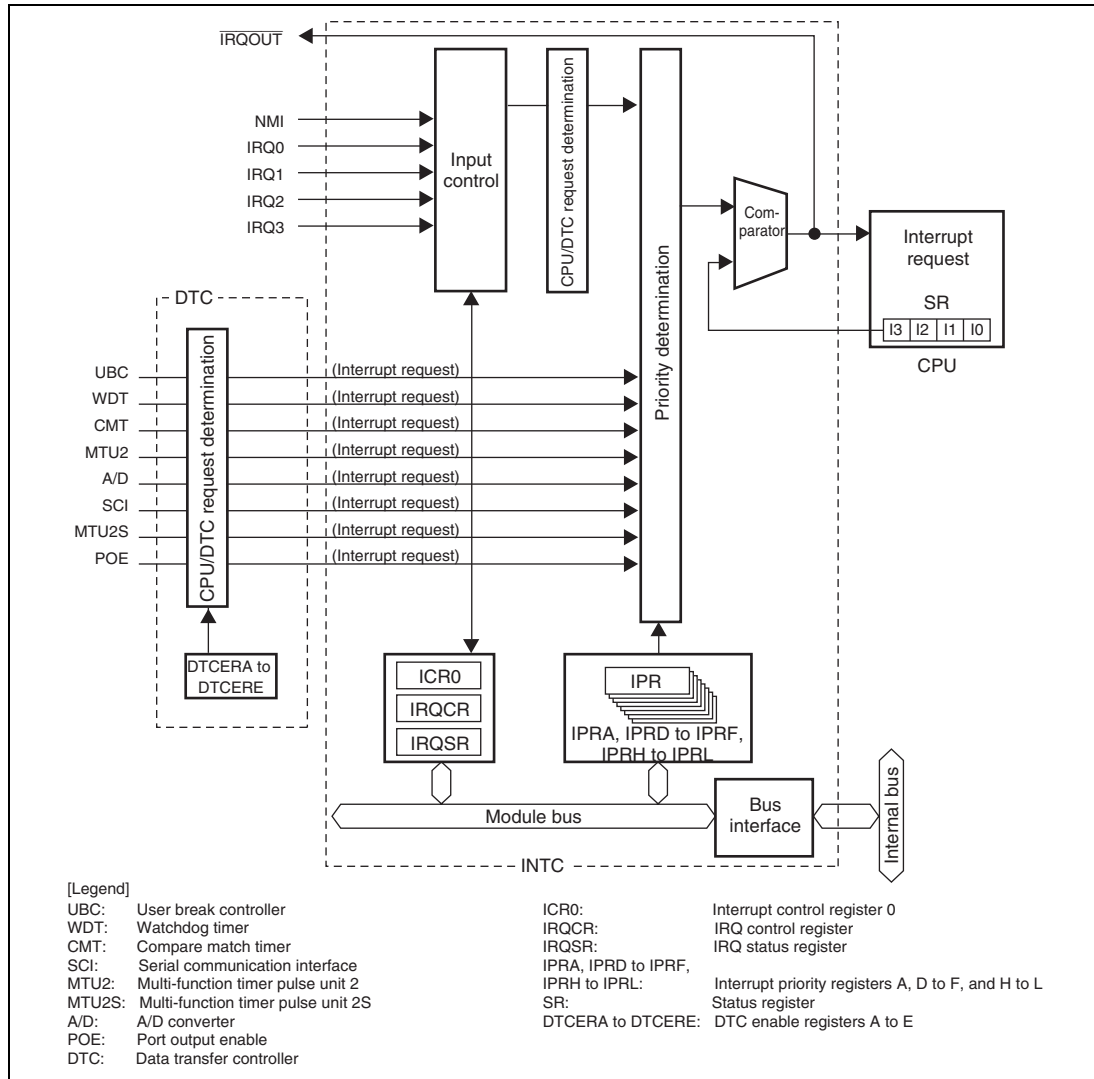

Figure 6.1 Block Diagram of INTC

6.2 Input/Output Pins

Table 6.1 shows the INTC pin configuration.

Table 6.1 Pin Configuration

Name	Symbol	I/O	Function
Non-maskable interrupt input pin	NMI	Input	Input of non-maskable interrupt request signal
Interrupt request input pins	IRQ0 to IRQ3	Input	Input of maskable interrupt request signals
Interrupt request output pin	$\overline{\text{IRQOUT}}$	Output	Output of notification signal when an interrupt has occurred

6.3 Register Descriptions

The interrupt controller has the following registers. For details on the addresses of these registers and the states of these registers in each processing state, see section 23, List of Registers.

Table 6.2 Register Configuration

Register Name	Abbreviation	R/W	Initial Value	Address	Access Size
Interrupt control register 0	ICR0	R/W	H'x000	H'FFFFFFE900	8, 16
IRQ control register	IRQCR	R/W	H'0000	H'FFFFFFE902	8, 16
IRQ status register	IRQSR	R/W	H'Fx00	H'FFFFFFE904	8, 16
Interrupt priority register A	IPRA	R/W	H'0000	H'FFFFFFE906	8, 16
Interrupt priority register D	IPRD	R/W	H'0000	H'FFFFFFE982	16
Interrupt priority register E	IPRE	R/W	H'0000	H'FFFFFFE984	16
Interrupt priority register F	IPRF	R/W	H'0000	H'FFFFFFE986	16
Interrupt priority register H	IPRH	R/W	H'0000	H'FFFFFFE98A	16
Interrupt priority register I	IPRI	R/W	H'0000	H'FFFFFFE98C	16
Interrupt priority register J	IPRJ	R/W	H'0000	H'FFFFFFE98E	16
Interrupt priority register K	IPRK	R/W	H'0000	H'FFFFFFE990	16
Interrupt priority register L	IPRL	R/W	H'0000	H'FFFFFFE992	16

6.3.1 Interrupt Control Register 0 (ICR0)

ICR0 is a 16-bit register that sets the input signal detection mode of the external interrupt input pin NMI and indicates the input signal level on the NMI pin.

Bit:	15	14	13	12	11	10	9	8	7	6	5	4	3	2	1	0
	NMIL	-	-	-	-	-	-	NMIE	-	-	-	-	-	-	-	-
Initial value:	*	0	0	0	0	0	0	0	0	0	0	0	0	0	0	0
R/W:	R	R	R	R	R	R	R	R/W	R	R	R	R	R	R	R	R

Note: * The initial value is 1 when the level on the NMI pin is high, and 0 when the level on the pin is low.

Bit	Bit Name	Initial Value	R/W	Description
15	NMIL	*	R	NMI Input Level Indicates the state of the signal input to the NMI pin. This bit can be read to determine the NMI pin level. This bit cannot be modified. 0: State of the NMI input is low 1: State of the NMI input is high
14 to 9	—	All 0	R	Reserved These bits are always read as 0. The write value should always be 0.
8	NMIE	0	R/W	NMI Edge Select 0: Interrupt request is detected on the falling edge of the NMI input 1: Interrupt request is detected on the rising edge of the NMI input
7 to 0	—	All 0	R	Reserved These bits are always read as 0. The write value should always be 0.

6.3.2 IRQ Control Register (IRQCR)

IRQCR is a 16-bit register that sets the input signal detection mode of the external interrupt input pins IRQ0 to IRQ3.

Bit:	15	14	13	12	11	10	9	8	7	6	5	4	3	2	1	0
	-	-	-	-	-	-	-	-	IRQ31S	IRQ30S	IRQ21S	IRQ20S	IRQ11S	IRQ10S	IRQ01S	IRQ00S
Initial value:	0	0	0	0	0	0	0	0	0	0	0	0	0	0	0	0
R/W:	R	R	R	R	R	R	R	R	R/W	R/W	R/W	R/W	R/W	R/W	R/W	R/W

Bit	Bit Name	Initial Value	R/W	Description
15 to 8	—	All 0	R	Reserved These bits are always read as 0. The write value should always be 0.
7	IRQ31S	0	R/W	IRQ3 Sense Select
6	IRQ30S	0	R/W	Set the interrupt request detection mode for pin IRQ3. 00: Interrupt request is detected at the low level of pin IRQ3 01: Interrupt request is detected at the falling edge of pin IRQ3 10: Interrupt request is detected at the rising edge of pin IRQ3 11: Interrupt request is detected at both the falling and rising edges of pin IRQ3
5	IRQ21S	0	R/W	IRQ2 Sense Select
4	IRQ20S	0	R/W	Set the interrupt request detection mode for pin IRQ2. 00: Interrupt request is detected at the low level of pin IRQ2 01: Interrupt request is detected at the falling edge of pin IRQ2 10: Interrupt request is detected at the rising edge of pin IRQ2 11: Interrupt request is detected at both the falling and rising edges of pin IRQ2

Bit	Bit Name	Initial Value	R/W	Description
3	IRQ11S	0	R/W	IRQ1 Sense Select
2	IRQ10S	0	R/W	Set the interrupt request detection mode for pin IRQ1. 00: Interrupt request is detected at the low level of pin IRQ1 01: Interrupt request is detected at the falling edge of pin IRQ1 10: Interrupt request is detected at the rising edge of pin IRQ1 11: Interrupt request is detected at both the falling and rising edges of pin IRQ1
1	IRQ01S	0	R/W	IRQ0 Sense Select
0	IRQ00S	0	R/W	Set the interrupt request detection mode for pin IRQ0. 00: Interrupt request is detected at the low level of pin IRQ0 01: Interrupt request is detected at the falling edge of pin IRQ0 10: Interrupt request is detected at the rising edge of pin IRQ0 11: Interrupt request is detected at both the falling and rising edges of pin IRQ0

6.3.3 IRQ Status register (IRQSR)

IRQSR is a 16-bit register that indicates the states of the external interrupt input pins IRQ0 to IRQ3 and the status of interrupt request.

Bit:	15	14	13	12	11	10	9	8	7	6	5	4	3	2	1	0
	-	-	-	-	IRQ3L	IRQ2L	IRQ1L	IRQ0L	-	-	-	-	IRQ3F	IRQ2F	IRQ1F	IRQ0F
Initial value:	1	1	1	1	*	*	*	*	0	0	0	0	0	0	0	0
R/W:	R	R	R	R	R	R	R	R	R	R	R	R	R/W	R/W	R/W	R/W

Note: * The initial value is 1 when the level on the corresponding IRQ pin is high, and 0 when the level on the pin is low.

Bit	Bit Name	Initial Value	R/W	Description
15 to 12	—	All 1	R	Reserved These bits are always read as 1. The write value should always be 1.
11	IRQ3L	*	R	Indicates the state of pin IRQ3. 0: State of pin IRQ3 is low 1: State of pin IRQ3 is high
10	IRQ2L	*	R	Indicates the state of pin IRQ2. 0: State of pin IRQ2 is low 1: State of pin IRQ2 is high
9	IRQ1L	*	R	Indicates the state of pin IRQ1. 0: State of pin IRQ1 is low 1: State of pin IRQ1 is high
8	IRQ0L	*	R	Indicates the state of pin IRQ0. 0: State of pin IRQ0 is low 1: State of pin IRQ0 is high
7 to 4	—	All 0	R	Reserved These bits are always read as 0. The write value should always be 0.

Bit	Bit Name	Initial Value	R/W	Description
3	IRQ3F	0	R/W	<p>Indicates the status of an IRQ3 interrupt request.</p> <ul style="list-style-type: none"> When level detection mode is selected <ul style="list-style-type: none"> 0: An IRQ3 interrupt has not been detected [Clearing condition] Driving pin IRQ3 high 1: An IRQ3 interrupt has been detected [Setting condition] Driving pin IRQ3 low When edge detection mode is selected <ul style="list-style-type: none"> 0: An IRQ3 interrupt has not been detected [Clearing conditions] <ul style="list-style-type: none"> — Writing 0 after reading IRQ3F = 1 — Accepting an IRQ3 interrupt 1: An IRQ3 interrupt request has been detected [Setting condition] Detecting the specified edge of pin IRQ3
2	IRQ2F	0	R/W	<p>Indicates the status of an IRQ2 interrupt request.</p> <ul style="list-style-type: none"> When level detection mode is selected <ul style="list-style-type: none"> 0: An IRQ2 interrupt has not been detected [Clearing condition] Driving pin IRQ2 high 1: An IRQ2 interrupt has been detected [Setting condition] Driving pin IRQ2 low When edge detection mode is selected <ul style="list-style-type: none"> 0: An IRQ2 interrupt has not been detected [Clearing conditions] <ul style="list-style-type: none"> — Writing 0 after reading IRQ2F = 1 — Accepting an IRQ2 interrupt 1: An IRQ2 interrupt request has been detected [Setting condition] Detecting the specified edge of pin IRQ2

Bit	Bit Name	Initial Value	R/W	Description
1	IRQ1F	0	R/W	<p>Indicates the status of an IRQ1 interrupt request.</p> <ul style="list-style-type: none"> When level detection mode is selected <ul style="list-style-type: none"> 0: An IRQ1 interrupt has not been detected [Clearing condition] Driving pin IRQ1 high 1: An IRQ1 interrupt has been detected [Setting condition] Driving pin IRQ1 low When edge detection mode is selected <ul style="list-style-type: none"> 0: An IRQ1 interrupt has not been detected [Clearing conditions] <ul style="list-style-type: none"> — Writing 0 after reading IRQ1F = 1 — Accepting an IRQ1 interrupt 1: An IRQ1 interrupt request has been detected [Setting condition] Detecting the specified edge of pin IRQ1
0	IRQ0F	0	R/W	<p>Indicates the status of an IRQ0 interrupt request.</p> <ul style="list-style-type: none"> When level detection mode is selected <ul style="list-style-type: none"> 0: An IRQ0 interrupt has not been detected [Clearing condition] Driving pin IRQ0 high 1: An IRQ0 interrupt has been detected [Setting condition] Driving pin IRQ0 low When edge detection mode is selected <ul style="list-style-type: none"> 0: An IRQ0 interrupt has not been detected [Clearing conditions] <ul style="list-style-type: none"> — Writing 0 after reading IRQ0F = 1 — Accepting an IRQ0 interrupt 1: An IRQ0 interrupt request has been detected [Setting condition] Detecting the specified edge of pin IRQ0

Note: * The initial value is 1 when the level on the corresponding IRQ pin is high, and 0 when the level on the pin is low.

6.3.4 Interrupt Priority Registers A, D to F, and H to L (IPRA, IPRD to IPRF, and IPRH to IPRL)

Interrupt priority registers are nine 16-bit readable/writable registers that set priority levels from 0 to 15 for interrupts except NMI. For the correspondence between interrupt request sources and IPR, refer to table 6.3. Each of the corresponding interrupt priority ranks are established by setting a value from H'0 to H'F in each of the four-bit groups 15 to 12, 11 to 8, 7 to 4 and 3 to 0. Reserved bits that are not assigned should be set H'0 (B'0000).

Bit:	15	14	13	12	11	10	9	8	7	6	5	4	3	2	1	0
	IPR[15:12]				IPR[11:8]				IPR[7:4]				IPR[3:0]			
Initial value:	0	0	0	0	0	0	0	0	0	0	0	0	0	0	0	0
R/W:	R/W	R/W	R/W	R/W	R/W	R/W	R/W	R/W	R/W	R/W	R/W	R/W	R/W	R/W	R/W	R/W

Bit	Bit Name	Initial Value	R/W	Description
15 to 12	IPR[15:12]	0000	R/W	Set priority levels for the corresponding interrupt source. 0000: Priority level 0 (lowest) 0001: Priority level 1 0010: Priority level 2 0011: Priority level 3 0100: Priority level 4 0101: Priority level 5 0110: Priority level 6 0111: Priority level 7 1000: Priority level 8 1001: Priority level 9 1010: Priority level 10 1011: Priority level 11 1100: Priority level 12 1101: Priority level 13 1110: Priority level 14 1111: Priority level 15 (highest)

Bit	Bit Name	Initial Value	R/W	Description
11 to 8	IPR[11:8]	0000	R/W	Set priority levels for the corresponding interrupt source. 0000: Priority level 0 (lowest) 0001: Priority level 1 0010: Priority level 2 0011: Priority level 3 0100: Priority level 4 0101: Priority level 5 0110: Priority level 6 0111: Priority level 7 1000: Priority level 8 1001: Priority level 9 1010: Priority level 10 1011: Priority level 11 1100: Priority level 12 1101: Priority level 13 1110: Priority level 14 1111: Priority level 15 (highest)
7 to 4	IPR[7:4]	0000	R/W	Set priority levels for the corresponding interrupt source. 0000: Priority level 0 (lowest) 0001: Priority level 1 0010: Priority level 2 0011: Priority level 3 0100: Priority level 4 0101: Priority level 5 0110: Priority level 6 0111: Priority level 7 1000: Priority level 8 1001: Priority level 9 1010: Priority level 10 1011: Priority level 11 1100: Priority level 12 1101: Priority level 13 1110: Priority level 14 1111: Priority level 15 (highest)

Bit	Bit Name	Initial Value	R/W	Description
3 to 0	IPR[3:0]	0000	R/W	Set priority levels for the corresponding interrupt source. 0000: Priority level 0 (lowest) 0001: Priority level 1 0010: Priority level 2 0011: Priority level 3 0100: Priority level 4 0101: Priority level 5 0110: Priority level 6 0111: Priority level 7 1000: Priority level 8 1001: Priority level 9 1010: Priority level 10 1011: Priority level 11 1100: Priority level 12 1101: Priority level 13 1110: Priority level 14 1111: Priority level 15 (highest)

Note: Name in the tables above is represented by a general name. Name in the list of register is, on the other hand, represented by a module name.

6.4 Interrupt Sources

6.4.1 External Interrupts

There are four types of interrupt sources: User break, NMI, IRQ, and on-chip peripheral modules. Individual interrupts are given priority levels (0 to 16, with 0 the lowest and 16 the highest). Giving an interrupt a priority level of 0 masks it.

NMI Interrupt: The NMI interrupt is given a priority level of 16 and is always accepted. An NMI interrupt is detected at the edge of the pins. Use the NMI edge select bit (NMIE) in interrupt control register 0 (ICR0) to select either the rising or falling edge. In the NMI interrupt exception handler, the interrupt mask level bits (I3 to I0) in the status register (SR) are set to level 15.

IRQ3 to IRQ0 Interrupts: IRQ interrupts are requested by input from pins IRQ0 to IRQ3. Use the IRQ sense select bits (IRQ31S, IRQ30S to IRQ01S, and IRQ00S) in the IRQ control register (IRQCR) to select the detection mode from low level detection, falling edge detection, rising edge detection, and both edge detection for each pin. The priority level can be set from 0 to 15 for each pin using the interrupt priority register A (IPRA).

In the case that the low level detection is selected, an interrupt request signal is sent to the INTC while the IRQ pin is driven low. The interrupt request signal stops to be sent to the INTC when the IRQ pin becomes high. It is possible to confirm that an interrupt is requested by reading the IRQ flags (IRQ3F to IRQ0F) in the IRQ status register (IRQSR).

In the case that the edge detection is selected, an interrupt request signal is sent to the INTC when the following change on the IRQ pin is detected: from high to low in falling edge detection mode, from low to high in rising edge detection mode, and from low to high or from high to low in both edge detection mode. The IRQ interrupt request by detecting the change on the pin is held until the interrupt request is accepted. It is possible to confirm that an IRQ interrupt request has been detected by reading the IRQ flags (IRQ3F to IRQ0F) in the IRQ status register (IRQSR). An IRQ interrupt request by detecting the change on the pin can be withdrawn by writing 0 to an IRQ flag after reading 1.

In the IRQ interrupt exception handling, the interrupt mask bits (I3 to I0) in the status register (SR) are set to the priority level value of the accepted IRQ interrupt. Figure 6.2 shows the block diagram of the IRQ3 to IRQ0 interrupts.

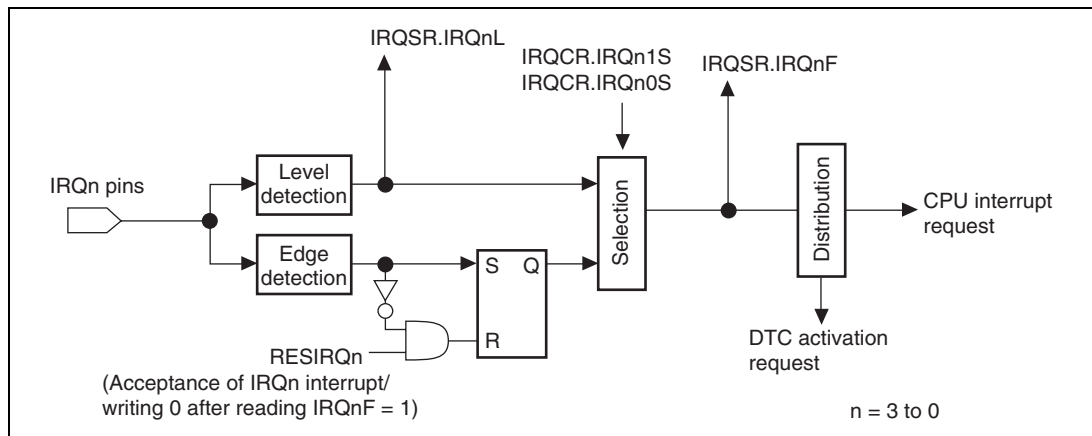

Figure 6.2 Block Diagram of IRQ3 to IRQ0 Interrupts Control

6.4.2 On-Chip Peripheral Module Interrupts

On-chip peripheral module interrupts are interrupts generated by the following on-chip peripheral modules.

Since a different interrupt vector is allocated to each interrupt source, the exception handling routine does not have to decide which interrupt has occurred. Priority levels between 0 and 15 can be allocated to individual on-chip peripheral modules in interrupt priority registers D to F and H to L (IPRD to IPRF and IPRH to IPRL). On-chip peripheral module interrupt exception handling sets the interrupt mask level bits (I3 to I0) in the status register (SR) to the priority level value of the on-chip peripheral module interrupt that was accepted.

6.4.3 User Break Interrupt

A user break interrupt has a priority level of 15, and occurs when the break condition set in the user break controller (UBC) is satisfied. User break interrupt requests are detected by edge and are held until accepted. User break interrupt exception handling sets the interrupt mask level bits (I3 to I0) in the status register (SR) to level 15. For more details on the user break interrupt, see section 7, User Break Controller (UBC).

6.5 Interrupt Exception Handling Vector Table

Table 6.3 lists interrupt sources, their vector numbers, vector table address offsets, and interrupt priorities.

Individual interrupt sources are allocated to different vector numbers and vector table address offsets. Vector table addresses are calculated from the vector numbers and vector table address offsets. For interrupt exception handling, the start address of the exception handling routine is fetched from the vector table address in the vector table. For the details on calculation of vector table addresses, see table 5.4.

IRQ interrupts and on-chip peripheral module interrupt priorities can be set freely between 0 and 15 for each pin or module by setting interrupt priority registers A, D to F and H to L (IPRA, IPRD to IPRF, and IPRH to IPRL). However, when interrupt sources whose priority levels are allocated with the same IPR are requested, the interrupt of the smaller vector number has priority. This priority cannot be changed. Priority levels of IRQ interrupts and on-chip peripheral module interrupts are initialized to level 0 at a power-on reset. If the same priority level is allocated to two or more interrupt sources and interrupts from those sources occur simultaneously, they are processed by the default priority order shown in table 6.3.

Table 6.3 Interrupt Exception Handling Vectors and Priorities

Interrupt Source	Name	Vector No.	Vector Table Starting Address	IPR	Default Priority
User break		12	H'00000030	—	High
External pin	NMI	11	H'0000002C	—	↑ ↓
	IRQ0	64	H'00000100	IPRA15 to IPRA12	
	IRQ1	65	H'00000104	IPRA11 to IPRA8	
	IRQ2	66	H'00000108	IPRA7 to IPRA4	
	IRQ3	67	H'0000010C	IPRA3 to IPRA0	
MTU2_0	TGIA_0	88	H'00000160	IPRD15 to IPRD12	
	TGIB_0	89	H'00000164		
	TGIC_0	90	H'00000168		
	TGID_0	91	H'0000016C		
	TCIV_0	92	H'00000170	IPRD11 to IPRD8	
	TGIE_0	93	H'00000174		
	TGIF_0	94	H'00000178		Low

Interrupt Source	Name	Vector No.	Vector Table Starting Address	IPR	Default Priority
MTU2_1	TGIA_1	96	H'00000180	IPRD7 to IPRD4	High
	TGIB_1	97	H'00000184		
	TCIV_1	100	H'00000190		
	TCIU_1	101	H'00000194		
MTU2_2	TGIA_2	104	H'000001A0	IPRE15 to IPRE12	
	TGIB_2	105	H'000001A4		
	TCIV_2	108	H'000001B0		
	TCIU_2	109	H'000001B4		
MTU2_3	TGIA_3	112	H'000001C0	IPRE7 to IPRE4	
	TGIB_3	113	H'000001C4		
	TGIC_3	114	H'000001C8		
	TGID_3	115	H'000001CC		
	TCIV_3	116	H'000001D0		
MTU2_4	TGIA_4	120	H'000001E0	IPRF15 to IPRF12	
	TGIB_4	121	H'000001E4		
	TGIC_4	122	H'000001E8		
	TGID_4	123	H'000001EC		
	TCIV_4	124	H'000001F0		
MTU2_5	TGIU_5	128	H'00000200	IPRF7 to IPRF4	
	TGIV_5	129	H'00000204		
	TGIW_5	130	H'00000208		
POE (MTU2)	OEI1	132	H'00000210	IPRF3 to IPRF0	
	OEI3	133	H'00000214		
MTU2S_3	TGIA_3S	160	H'00000280	IPRH7 to IPRH4	
	TGIB_3S	161	H'00000284		
	TGIC_3S	162	H'00000288		
	TGID_3S	163	H'0000028C		
	TCIV_3S	164	H'00000290		

Interrupt Source	Name	Vector No.	Vector Table Starting Address	IPR	Default Priority
MTU2S_4	TGIA_4S	168	H'000002A0	IPRI15 to IPRI12	High
	TGIB_4S	169	H'000002A4		
	TGIC_4S	170	H'000002A8		
	TGID_4S	171	H'000002AC		
	TCIV_4S	172	H'000002B0		
MTU2S_5	TGIU_5S	176	H'000002C0	IPRI7 to IPRI4	
	TGIV_5S	177	H'000002C4		
	TGIW_5S	178	H'000002C8		
POE (MTU2S)	OEI2	180	H'000002D0	IPRI3 to IPRI0	
CMT_0	CMI_0	184	H'000002E0	IPRJ15 to IPRJ12	
CMT_1	CMI_1	188	H'000002F0	IPRJ11 to IPRJ8	
WDT	ITI	196	H'00000310	IPRJ3 to IPRJ0	
A/D_0 and A/D_1	ADI_0	200	H'00000320	IPRK15 to IPRK12	
	ADI_1	201	H'00000324		
A/D_2	ADI_2	204	H'00000330	IPRK11 to IPRK8	
SCI_0	ERI_0	216	H'00000360	IPRL15 to IPRL12	
	RXI_0	217	H'00000364		
	TXI_0	218	H'00000368		
	TEI_0	219	H'0000036C		
SCI_1	ERI_1	220	H'00000370	IPRL11 to IPRL8	
	RXI_1	221	H'00000374		
	TXI_1	222	H'00000378		
	TEI_1	223	H'0000037C		
SCI_2	ERI_2	224	H'00000380	IPRL7 to IPRL4	
	RXI_2	225	H'00000384		
	TXI_2	226	H'00000388		
	TEI_2	227	H'0000038C		

6.6 Interrupt Operation

6.6.1 Interrupt Sequence

The sequence of interrupt operations is explained below. Figure 6.3 is a flowchart of the operations.

1. The interrupt request sources send interrupt request signals to the interrupt controller.
2. The interrupt controller selects the highest priority interrupt from interrupt requests sent, according to the priority levels set in interrupt priority registers A, D to F, and H to L (IPRA, IPRD to IPRF, and IPRH to IPRL). Interrupts that have lower-priority than that of the selected interrupt are ignored*. If interrupts that have the same priority level or interrupts within a same module occur simultaneously, the interrupt with the highest priority is selected according to the default priority shown in table 6.3.
3. The interrupt controller compares the priority level of the selected interrupt request with the interrupt mask bits (I3 to I0) in the status register (SR) of the CPU. If the priority level of the selected request is equal to or less than the level set in bits I3 to I0, the request is ignored. If the priority level of the selected request is higher than the level in bits I3 to I0, the interrupt controller accepts the request and sends an interrupt request signal to the CPU.
4. When the interrupt controller accepts an interrupt, a low level is output from the $\overline{\text{IRQOUT}}$ pin.
5. The CPU detects the interrupt request sent from the interrupt controller in the decode stage of an instruction to be executed. Instead of executing the decoded instruction, the CPU starts interrupt exception handling.
6. SR and PC are saved onto the stack.
7. The priority level of the accepted interrupt is copied to bits (I3 to I0) in SR.
8. When the accepted interrupt is sensed by level or is from an on-chip peripheral module, a high level is output from the $\overline{\text{IRQOUT}}$ pin. When the accepted interrupt is sensed by edge, a high level is output from the $\overline{\text{IRQOUT}}$ pin at the moment when the CPU starts interrupt exception processing instead of instruction execution as noted in 5. above. However, if the interrupt controller accepts an interrupt with a higher priority than the interrupt just to be accepted, the $\overline{\text{IRQOUT}}$ pin holds low level.
9. The CPU reads the start address of the exception handling routine from the exception vector table for the accepted interrupt, branches to that address, and starts executing the program. This branch is not a delayed branch.

Notes: The interrupt source flag should be cleared in the interrupt handler. To ensure that an interrupt source that should have been cleared is not inadvertently accepted again, read the interrupt source flag after it has been cleared, confirm that it has been cleared, and then execute an RTE instruction.

- * Interrupt requests that are designated as edge-detect type are held pending until the interrupt requests are accepted. IRQ interrupts, however, can be cancelled by accessing the IRQ status register (IRQSR). Interrupts held pending due to edge detection are cleared by a power-on reset or a manual reset.

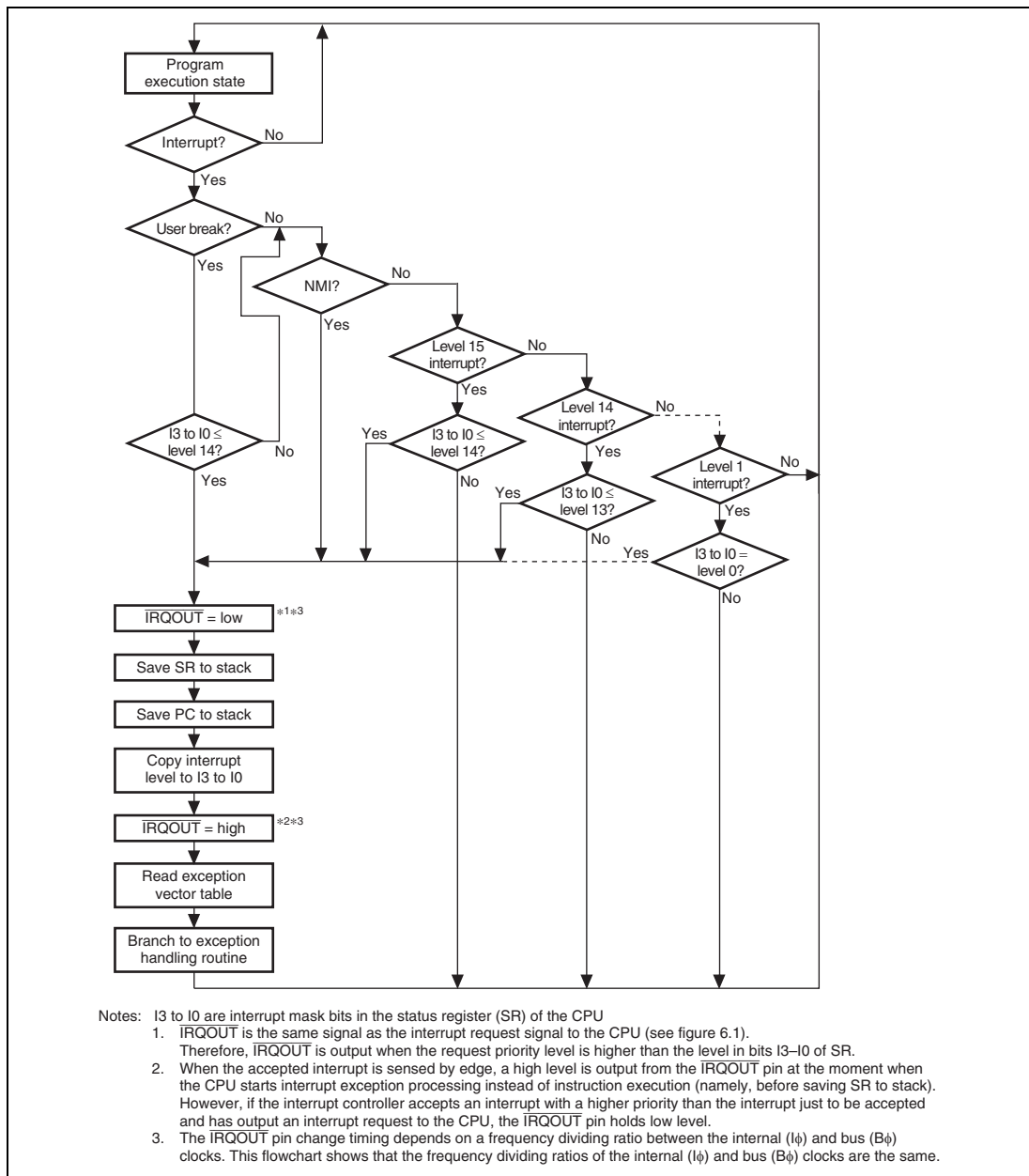

Figure 6.3 Interrupt Sequence Flowchart

6.6.2 Stack after Interrupt Exception Handling

Figure 6.4 shows the stack after interrupt exception handling.

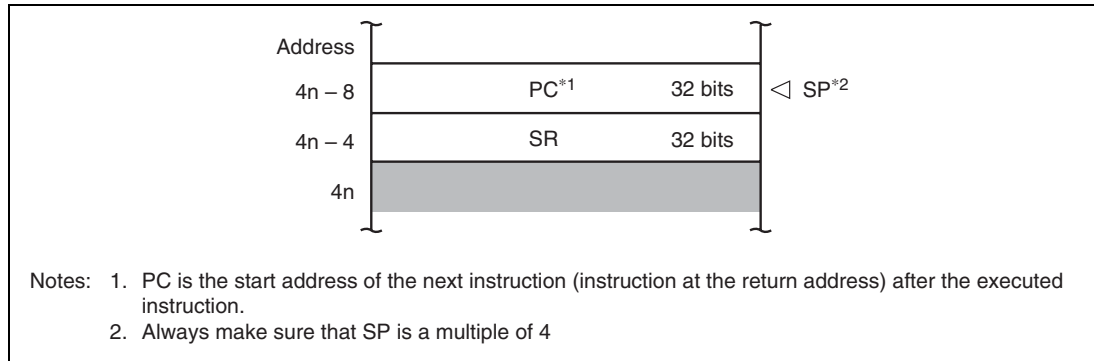

Figure 6.4 Stack after Interrupt Exception Handling

6.7 Interrupt Response Time

Table 6.4 lists the interrupt response time, which is the time from the occurrence of an interrupt request until the interrupt exception handling starts and fetching of the first instruction of the interrupt handling routine begins.

Table 6.4 Interrupt Response Time

Item	Number of Cycles			Remarks	
	NMI	IRQ	Peripheral Modules		
DTC active judgment	—	$2 \times \text{Bcyc}$	$1 \times \text{Pcyc}$		
Interrupt priority decision and comparison with mask bits in SR	$1 \times \text{Icyc} + 2 \times \text{Pcyc}$	$1 \times \text{Icyc} + 1 \times \text{Pcyc}$	$1 \times \text{Icyc} + 2 \times \text{Pcyc}$		
Wait for completion of sequence currently being executed by CPU	$X (\geq 0)$	$X (\geq 0)$	$X (\geq 0)$	The longest sequence is for interrupt or address-error exception handling ($X = 7 \times \text{Icyc} + m1 + m2 + m3 + m4$). If an interrupt-masking instruction follows, however, the time may be even longer.	
Time from start of interrupt exception handling until fetch of first instruction of exception handling routine starts	$8 \times \text{Icyc} + m1 + m2 + m3$	$8 \times \text{Icyc} + m1 + m2 + m3$	$8 \times \text{Icyc} + m1 + m2 + m3$	Performs the saving PC and SR, and vector address fetch.	
Interrupt response time	Total: $9 \times \text{Icyc} + 2 \times \text{Pcyc} + m1 + m2 + m3 + X$	$9 \times \text{Icyc} + 1 \times \text{Pcyc} + 2 \times \text{Bcyc} + m1 + m2 + m3 + X$	$9 \times \text{Icyc} + 3 \times \text{Pcyc} + m1 + m2 + m3 + X$		
	Minimum*:	$12 \times \text{Icyc} + 2 \times \text{Pcyc}$	$12 \times \text{Icyc} + 1 \times \text{Pcyc} + 2 \times \text{Bcyc}$	$12 \times \text{Icyc} + 3 \times \text{Pcyc}$	SR, PC, and vector table are all in on-chip RAM.
	Maximum:	$16 \times \text{Icyc} + 2 \times \text{Pcyc} + 2 \times (m1 + m2 + m3) + m4$	$16 \times \text{Icyc} + 1 \times \text{Pcyc} + 2 \times \text{Bcyc} + 2 \times (m1 + m2 + m3) + m4$	$16 \times \text{Icyc} + 3 \times \text{Pcyc} + 2 \times (m1 + m2 + m3) + m4$	

Notes: * In the case that $m1 = m2 = m3 = m4 = 1 \times \text{Icyc}$.
 $m1$ to $m4$ are the number of cycles needed for the following memory accesses.
 $m1$: SR save (longword write)
 $m2$: PC save (longword write)
 $m3$: Vector address read (longword read)
 $m4$: Fetch first instruction of interrupt service routine

6.8 Data Transfer with Interrupt Request Signals

The following data transfers can be done using interrupt request signals:

- Activate DTC only; CPU interrupts depend on DTC settings

The INTC masks a CPU interrupt when the corresponding DTCE bit is 1. The conditions for clearing DTCE and interrupt source flag are shown below.

DTCE clear condition = DTC transfer end • DTCECLR

Interrupt source flag clear condition = DTC transfer end • $\overline{\text{DTCECLR}}$

where DTCECLR = DISEL + counter 0

Figures 6.5 and 6.6 show control block diagrams.

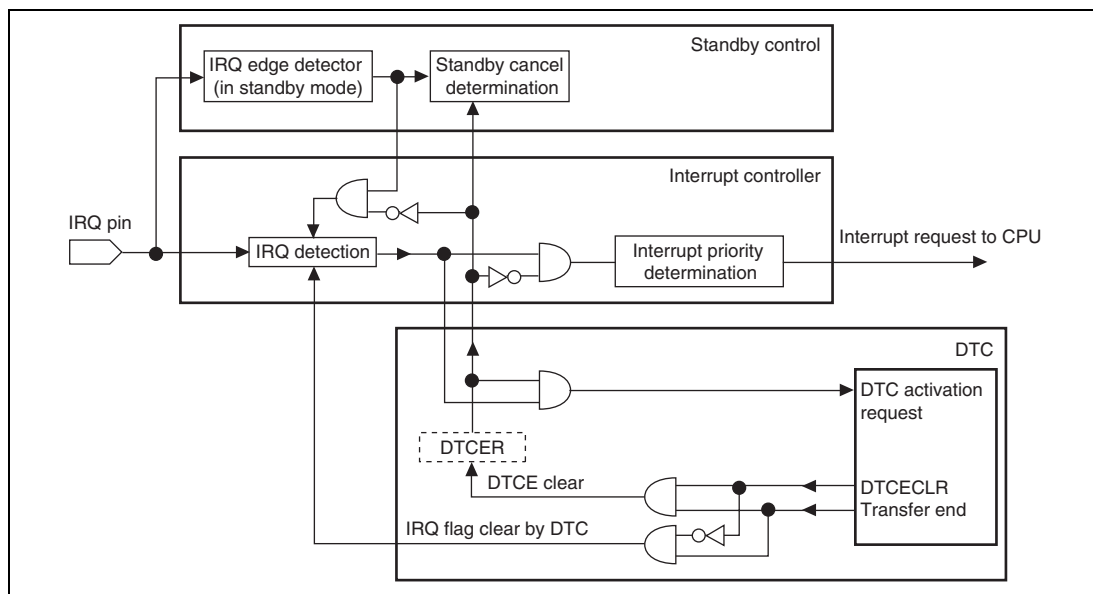

Figure 6.5 IRQ Interrupt Control Block Diagram

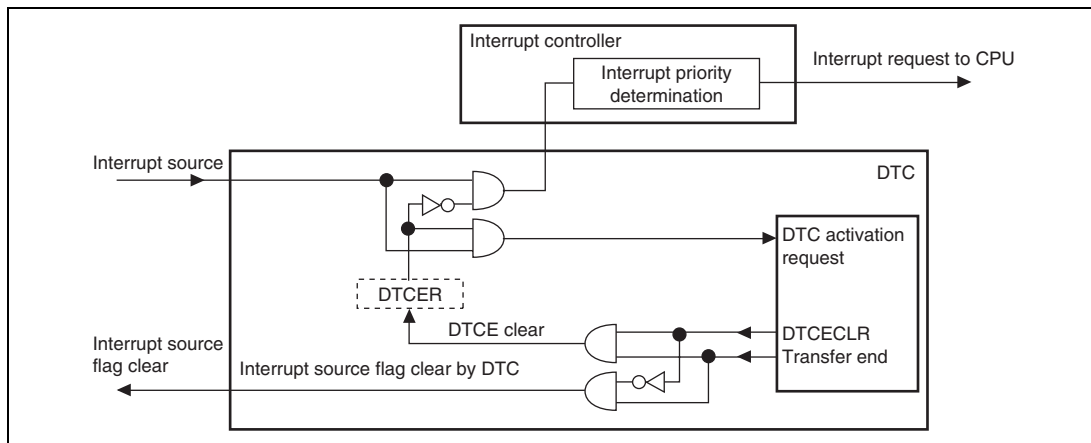

Figure 6.6 On-Chip Module Interrupt Control Block Diagram

6.8.1 Handling Interrupt Request Signals as Sources for DTC Activation and CPU Interrupts

1. For DTC, set the corresponding DTCE bits and DISEL bits to 1.
2. When an interrupt occurs, an activation request is sent to the DTC.
3. When completing a data transfer, the DTC clears the DTCE bit to 0 and sends an interrupt request to the CPU. The activation source is not cleared.
4. The CPU clears the interrupt source in the interrupt handling routine then checks the transfer counter value. When the transfer counter value is not 0, the CPU sets the DTCE bit to 1 and allows the next data transfer. If the transfer counter value = 0, the CPU performs the necessary end processing in the interrupt processing routine.

6.8.2 Handling Interrupt Request Signals as Sources for DTC Activation, but Not CPU Interrupts

1. For DTC, set the corresponding DTCE bits to 1 and clear the DISEL bits to 0.
2. When an interrupt occurs, an activation request is sent to the DTC.
3. When completing a data transfer, the DTC clears the activation source. No interrupt request is sent to the CPU because the DTCE bit is held at 1.
4. However, when the transfer counter value = 0, the DTCE bit is cleared to 0 and an interrupt request is sent to the CPU.
5. The CPU performs the necessary end processing in the interrupt handling routine.

6.8.3 Handling Interrupt Request Signals as Sources for CPU Interrupts, but Not DTC Activation

1. For DTC, clear the corresponding DTCE bits to 0.
2. When an interrupt occurs, an interrupt request is sent to the CPU.
3. The CPU clears the interrupt source and performs the necessary processing in the interrupt handling routine.

6.9 Usage Note

The interrupt source flag should be cleared in the interrupt handler. To ensure that an interrupt source that should have been cleared is not inadvertently accepted again, read the interrupt source flag after it has been cleared, confirm that it has been cleared, and then execute an RTE instruction.

Section 7 User Break Controller (UBC)

The user break controller (UBC) provides functions that simplify program debugging. These functions make it easy to design an effective self-monitoring debugger, enabling the chip to debug programs without using an in-circuit emulator. Break conditions that can be set in the UBC are instruction fetch or data read/write access, data size, data contents, address value, and stop timing in the case of instruction fetch.

In the masked ROM version, only the L bus instruction fetch address break (two channels) can be set.

7.1 Features

The UBC has the following features:

1. The following break comparison conditions can be set.
 - Number of break channels: two channels (channels A and B)
 - User break can be requested as either the independent or sequential condition on channels A and B (sequential break setting: channel A and then channel B match with break conditions, but not in the same bus cycle).
 - Address
 - Comparison bits are maskable in 1-bit units.
 - One of the two address buses (L-bus address (LAB) and I-bus address (IAB)) can be selected.
 - Data
 - 32-bit maskable.
 - One of the two data buses (L-bus data (LDB) and I-bus data (IDB)) can be selected.
 - Bus cycle
 - Instruction fetch or data access
 - Read/write
 - Operand size
 - Byte, word, and longword
2. A user-designed user-break interrupt exception processing routine can be run.
3. In an instruction fetch cycle, it can be selected that a user break is set before or after an instruction is executed.
4. Maximum repeat times for the break condition (only for channel B): $2^{12} - 1$ times.
5. Eight pairs of branch source/destination buffers.

Figure 7.1 shows a block diagram of the UBC.

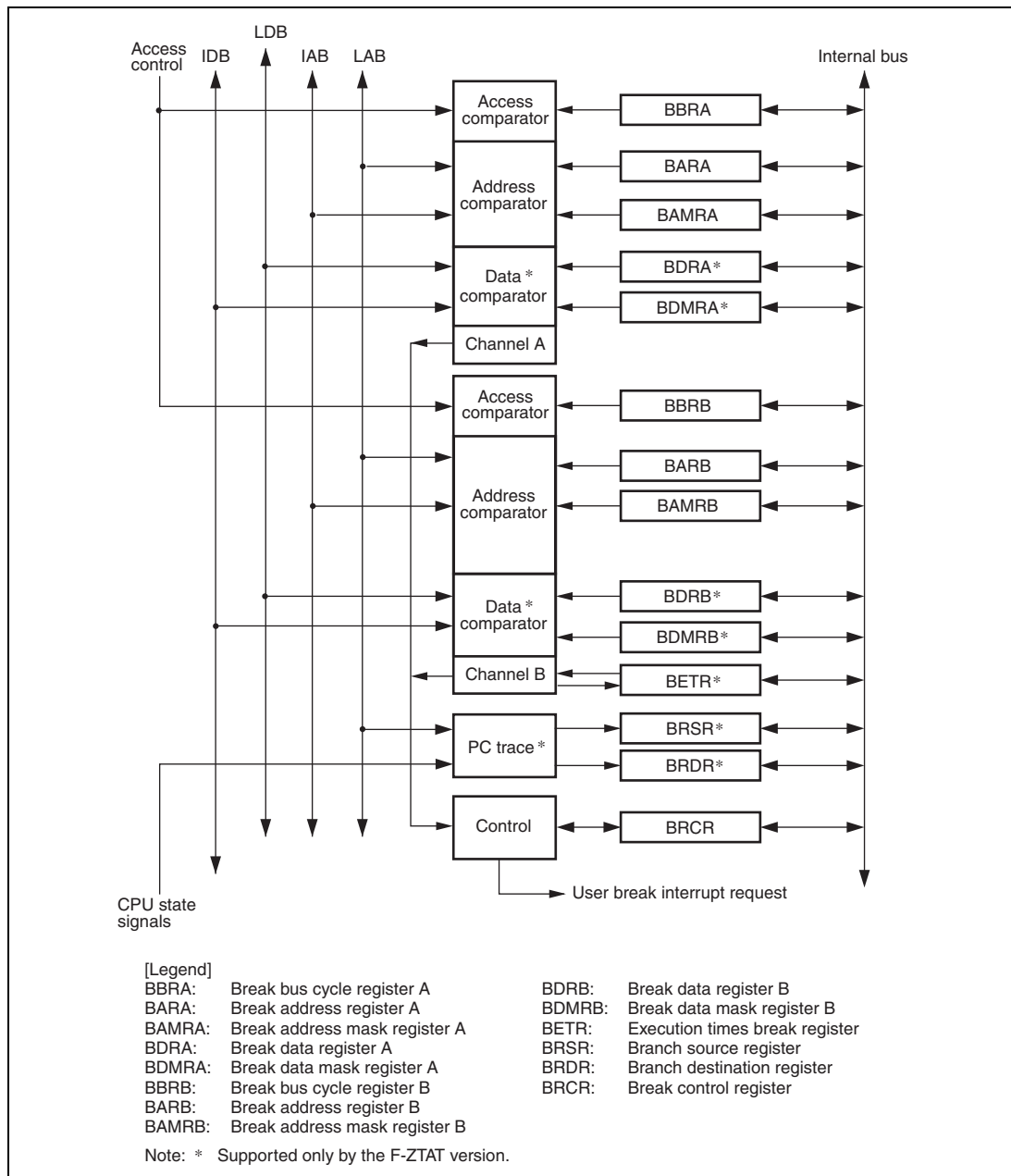

Figure 7.1 Block Diagram of UBC

7.2 Input/Output Pins

Table 7.1 shows the UBC pin configuration.

Table 7.1 Pin Configuration

Pin Name	Symbol	I/O	Function
User break trigger output	$\overline{\text{UBCTRG}}$	Output	UBC condition match trigger output pin.

7.3 Register Descriptions

The user break controller has the following registers. For details on register addresses and register states during each processing, refer to section 23, List of Registers.

Table 7.2 Register Configuration

Register Name	Abbreviation	R/W	Initial Value	Address	Access Size
Break address register A	BARA	R/W	H'00000000	H'FFFFFF300	32
Break address mask register A	BAMRA	R/W	H'00000000	H'FFFFFF304	32
Break bus cycle register A	BBRA	R/W	H'0000	H'FFFFFF308	16
Break data register A	BDRA*	R/W	H'00000000	H'FFFFFF310	32
Break data mask register A	BDMRA*	R/W	H'00000000	H'FFFFFF314	32
Break address register B	BARB	R/W	H'00000000	H'FFFFFF320	32
Break address mask register B	BAMRB	R/W	H'00000000	H'FFFFFF324	32
Break bus cycle register B	BBRB	R/W	H'0000	H'FFFFFF328	16
Break data register B	BDRB*	R/W	H'00000000	H'FFFFFF330	32
Break data mask register B	BDMRB*	R/W	H'00000000	H'FFFFFF334	32
Break control register	BRCR	R/W	H'00000000	H'FFFFFF3C0	32
Branch source register	BRSR*	R	H'0xxxxxxx	H'FFFFFF3D0	32
Branch destination register	BRDR*	R	H'0xxxxxxx	H'FFFFFF3D4	32
Execution times break register	BETR*	R/W	H'0000	H'FFFFFF3DC	16

Note: * Supported only in the F-ZTAT version.

7.3.1 Break Address Register A (BARA)

BARA is a 32-bit readable/writable register. BARA specifies the address used as a break condition in channel A.

Bit:	31	30	29	28	27	26	25	24	23	22	21	20	19	18	17	16
	BAA31	BAA30	BAA29	BAA28	BAA27	BAA26	BAA25	BAA24	BAA23	BAA22	BAA21	BAA20	BAA19	BAA18	BAA17	BAA16
Initial value:	0	0	0	0	0	0	0	0	0	0	0	0	0	0	0	0
R/W:	R/W	R/W	R/W	R/W	R/W	R/W	R/W	R/W	R/W	R/W	R/W	R/W	R/W	R/W	R/W	R/W

Bit:	15	14	13	12	11	10	9	8	7	6	5	4	3	2	1	0
	BAA15	BAA14	BAA13	BAA12	BAA11	BAA10	BAA9	BAA8	BAA7	BAA6	BAA5	BAA4	BAA3	BAA2	BAA1	BAA0
Initial value:	0	0	0	0	0	0	0	0	0	0	0	0	0	0	0	0
R/W:	R/W	R/W	R/W	R/W	R/W	R/W	R/W	R/W	R/W	R/W	R/W	R/W	R/W	R/W	R/W	R/W

Bit	Bit Name	Initial Value	R/W	Description
31 to 0	BAA31 to BAA 0	All 0	R/W	Break Address A Store the address on the LAB or IAB specifying break conditions of channel A.

7.3.2 Break Address Mask Register A (BAMRA)

BAMRA is a 32-bit readable/writable register. BAMRA specifies bits masked in the break address specified by BARA.

Bit:	31	30	29	28	27	26	25	24	23	22	21	20	19	18	17	16
	BAMA31	BAMA30	BAMA29	BAMA28	BAMA27	BAMA26	BAMA25	BAMA24	BAMA23	BAMA22	BAMA21	BAMA20	BAMA19	BAMA18	BAMA17	BAMA16
Initial value:	0	0	0	0	0	0	0	0	0	0	0	0	0	0	0	0
R/W:	R/W	R/W	R/W	R/W	R/W	R/W	R/W	R/W	R/W	R/W	R/W	R/W	R/W	R/W	R/W	R/W

Bit:	15	14	13	12	11	10	9	8	7	6	5	4	3	2	1	0
	BAMA15	BAMA14	BAMA13	BAMA12	BAMA11	BAMA10	BAMA9	BAMA8	BAMA7	BAMA6	BAMA5	BAMA4	BAMA3	BAMA2	BAMA1	BAMA0
Initial value:	0	0	0	0	0	0	0	0	0	0	0	0	0	0	0	0
R/W:	R/W	R/W	R/W	R/W	R/W	R/W	R/W	R/W	R/W	R/W	R/W	R/W	R/W	R/W	R/W	R/W

Bit	Bit Name	Initial Value	R/W	Description
31 to 0	BAMA31 to BAMA0	All 0	R/W	<p>Break Address Mask A</p> <p>Specify bits masked in the channel A break address bits specified by BARA (BAA31 to BAA0).</p> <p>0: Break address bit BAAn of channel A is included in the break condition</p> <p>1: Break address bit BAAn of channel A is masked and is not included in the break condition</p> <p>Note: n = 31 to 0</p>

7.3.3 Break Bus Cycle Register A (BBRA)

BBRA is a 16-bit readable/writable register, which specifies (1) bus master for I bus cycle, (2) L bus cycle or I bus cycle, (3) instruction fetch or data access, (4) read or write, and (5) operand size in the break conditions of channel A.

Bit:	15	14	13	12	11	10	9	8	7	6	5	4	3	2	1	0
	-	-	-	-	-	CPA2*	CPA1*	CPA0*	CDA1*	CDA0	IDA1*	IDA0	RWA1*	RWA0	SZA1*	SZA0*
Initial value:	0	0	0	0	0	0	0	0	0	0	0	0	0	0	0	0
R/W:	R	R	R	R	R	R/W	R/W	R/W	R/W	R/W	R/W	R/W	R/W	R/W	R/W	R/W

Note: * In the masked ROM version, this bit is used as a reserved bit. This bit is always read as 0. The write value should always be 0.

Bit	Bit Name	Initial Value	R/W	Description
15 to 11	—	All 0	R	<p>Reserved</p> <p>These bits are always read as 0. The write value should always be 0.</p>
10	CPA2*	0	R/W	Bus Master Select A for I Bus
9	CPA1*	0	R/W	Select the bus master when the I bus is selected as the bus cycle of the channel A break condition. However, when the L bus is selected as the bus cycle, the setting of the CPA2 to CPA0 bits is disabled.
8	CPA0*	0	R/W	<p>000: Condition comparison is not performed</p> <p>xx1: The CPU cycle is included in the break condition</p> <p>x1x: Setting prohibited</p> <p>1xx: The DTC cycle is included in the break condition</p>

Bit	Bit Name	Initial Value	R/W	Description
7	CDA1*	0	R/W	L Bus Cycle/I Bus Cycle Select A
6	CDA0	0	R/W	Select the L bus cycle or I bus cycle as the bus cycle of the channel A break condition. 00: Condition comparison is not performed 01: The break condition is the L bus cycle 10: The break condition is the I bus cycle 11: The break condition is the L bus cycle
5	IDA1*	0	R/W	Instruction Fetch/Data Access Select A
4	IDA0	0	R/W	Select the instruction fetch cycle or data access cycle as the bus cycle of the channel A break condition. 00: Condition comparison is not performed 01: The break condition is the instruction fetch cycle 10: The break condition is the data access cycle 11: The break condition is the instruction fetch cycle or data access cycle
3	RWA1*	0	R/W	Read/Write Select A
2	RWA0	0	R/W	Select the read cycle or write cycle as the bus cycle of the channel A break condition. 00: Condition comparison is not performed 01: The break condition is the read cycle 10: The break condition is the write cycle 11: The break condition is the read cycle or write cycle
1	SZA1*	0	R/W	Operand Size Select A
0	SZA0*	0	R/W	Select the operand size of the bus cycle for the channel A break condition. 00: The break condition does not include operand size 01: The break condition is byte access 10: The break condition is word access 11: The break condition is longword access Note: When specifying the operand size, specify the size which matches the address boundary.

[Legend]

x: Don't care.

Note: * In the masked ROM version, these bits are reserved bits. They are always read as 0, and the write value should always be 0.

7.3.4 Break Data Register A (BDRA) (F-ZTAT Version Only)

BDRA is a 32-bit readable/writable register. The control bits CDA1 and CDA0 in BBRA select one of two data buses for break condition A.

Bit:	31	30	29	28	27	26	25	24	23	22	21	20	19	18	17	16
	BDA31	BDA30	BDA29	BDA28	BDA27	BDA26	BDA25	BDA24	BDA23	BDA22	BDA21	BDA20	BDA19	BDA18	BDA17	BDA16
Initial value:	0	0	0	0	0	0	0	0	0	0	0	0	0	0	0	0
R/W:	R/W	R/W	R/W	R/W	R/W	R/W	R/W	R/W	R/W	R/W	R/W	R/W	R/W	R/W	R/W	R/W

Bit:	15	14	13	12	11	10	9	8	7	6	5	4	3	2	1	0
	BDA15	BDA14	BDA13	BDA12	BDA11	BDA10	BDA9	BDA8	BDA7	BDA6	BDA5	BDA4	BDA3	BDA2	BDA1	BDA0
Initial value:	0	0	0	0	0	0	0	0	0	0	0	0	0	0	0	0
R/W:	R/W	R/W	R/W	R/W	R/W	R/W	R/W	R/W	R/W	R/W	R/W	R/W	R/W	R/W	R/W	R/W

Bit	Bit Name	Initial Value	R/W	Description
31 to 0	BDA31 to BDA0	All 0	R/W	<p>Break Data Bit A</p> <p>Stores data which specifies a break condition in channel A.</p> <p>If the I bus is selected in BBRA, the break data on IDB is set in BDA31 to BDA0.</p> <p>If the L bus is selected in BBRA, the break data on LDB is set in BDA31 to BDA0.</p>

- Notes:
1. Specify an operand size when including the value of the data bus in the break condition.
 2. When the byte size is selected as a break condition, the same byte data must be set in bits 15 to 8 and 7 to 0 in BDRA as the break data.

7.3.5 Break Data Mask Register A (BDMRA) (F-ZTAT Version Only)

BDMRA is a 32-bit readable/writable register. BDMRA specifies bits masked in the break data specified by BDRA.

Bit:	31	30	29	28	27	26	25	24	23	22	21	20	19	18	17	16
	BDMA31	BDMA30	BDMA29	BDMA28	BDMA27	BDMA26	BDMA25	BDMA24	BDMA23	BDMA22	BDMA21	BDMA20	BDMA19	BDMA18	BDMA17	BDMA16
Initial value:	0	0	0	0	0	0	0	0	0	0	0	0	0	0	0	0
R/W:	R/W	R/W	R/W	R/W	R/W	R/W	R/W	R/W	R/W	R/W	R/W	R/W	R/W	R/W	R/W	R/W

Bit:	15	14	13	12	11	10	9	8	7	6	5	4	3	2	1	0
	BDMA15	BDMA14	BDMA13	BDMA12	BDMA11	BDMA10	BDMA9	BDMA8	BDMA7	BDMA6	BDMA5	BDMA4	BDMA3	BDMA2	BDMA1	BDMA0
Initial value:	0	0	0	0	0	0	0	0	0	0	0	0	0	0	0	0
R/W:	R/W	R/W	R/W	R/W	R/W	R/W	R/W	R/W	R/W	R/W	R/W	R/W	R/W	R/W	R/W	R/W

Bit	Bit Name	Initial Value	R/W	Description
31 to 0	BDMA31 to BDMA 0	All 0	R/W	<p>Break Data Mask A</p> <p>Specifies bits masked in the break data of channel A specified by BDRA (BDA31 to BDA0).</p> <p>0: Break data BDAn of channel A is included in the break condition</p> <p>1: Break data BDAn of channel A is masked and is not included in the break condition</p> <p>Note: n = 31 to 0</p>

- Notes:
1. Specify an operand size when including the value of the data bus in the break condition.
 2. When the byte size is selected as a break condition, the same byte data must be set in bits 15 to 8 and 7 to 0 in BDMRA as the break mask data in BDRA.

7.3.6 Break Address Register B (BARB)

BARB is a 32-bit readable/writable register. BARB specifies the address used as a break condition in channel B. Control bits CDB1 and CDB0 in BBRB select one of the two address buses for break condition B.

Bit:	31	30	29	28	27	26	25	24	23	22	21	20	19	18	17	16
	BAB31	BAB30	BAB29	BAB28	BAB27	BAB26	BAB25	BAB24	BAB23	BAB22	BAB21	BAB20	BAB19	BAB18	BAB17	BAB16
Initial value:	0	0	0	0	0	0	0	0	0	0	0	0	0	0	0	0
R/W:	R/W	R/W	R/W	R/W	R/W	R/W	R/W	R/W	R/W	R/W	R/W	R/W	R/W	R/W	R/W	R/W
Bit:	15	14	13	12	11	10	9	8	7	6	5	4	3	2	1	0
	BAB15	BAB14	BAB13	BAB12	BAB11	BAB10	BAB9	BAB8	BAB7	BAB6	BAB5	BAB4	BAB3	BAB2	BAB1	BAB0
Initial value:	0	0	0	0	0	0	0	0	0	0	0	0	0	0	0	0
R/W:	R/W	R/W	R/W	R/W	R/W	R/W	R/W	R/W	R/W	R/W	R/W	R/W	R/W	R/W	R/W	R/W

Bit	Bit Name	Initial Value	R/W	Description
31 to 0	BAB31 to BAB 0	All 0	R/W	Break Address B Stores an address which specifies a break condition in channel B. If the I bus or L bus is selected in BBRB, an IAB or LAB address is set in BAB31 to BAB0.

7.3.7 Break Address Mask Register B (BAMRB)

BAMRB is a 32-bit readable/writable register. BAMRB specifies bits masked in the break address specified by BARB.

Bit:	31	30	29	28	27	26	25	24	23	22	21	20	19	18	17	16
	BAMB31	BAMB30	BAMB29	BAMB28	BAMB27	BAMB26	BAMB25	BAMB24	BAMB23	BAMB22	BAMB21	BAMB20	BAMB19	BAMB18	BAMB17	BAMB16
Initial value:	0	0	0	0	0	0	0	0	0	0	0	0	0	0	0	0
R/W:	R/W	R/W	R/W	R/W	R/W	R/W	R/W	R/W	R/W	R/W	R/W	R/W	R/W	R/W	R/W	R/W

Bit:	15	14	13	12	11	10	9	8	7	6	5	4	3	2	1	0
	BAMB15	BAMB14	BAMB13	BAMB12	BAMB11	BAMB10	BAMB9	BAMB8	BAMB7	BAMB6	BAMB5	BAMB4	BAMB3	BAMB2	BAMB1	BAMB0
Initial value:	0	0	0	0	0	0	0	0	0	0	0	0	0	0	0	0
R/W:	R/W	R/W	R/W	R/W	R/W	R/W	R/W	R/W	R/W	R/W	R/W	R/W	R/W	R/W	R/W	R/W

Bit	Bit Name	Initial Value	R/W	Description
31 to 0	BAMB31 to BAMB 0	All 0	R/W	<p>Break Address Mask B</p> <p>Specifies bits masked in the break address of channel B specified by BARB (BAB31 to BAB0).</p> <p>0: Break address BABn of channel B is included in the break condition</p> <p>1: Break address BABn of channel B is masked and is not included in the break condition</p> <p>Note: n = 31 to 0</p>

7.3.8 Break Data Register B (BDRB) (F-ZTAT Version Only)

BDRB is a 32-bit readable/writable register. The control bits CDB1 and CDB0 in BBRB select one of the two data buses for break condition B.

Bit:	31	30	29	28	27	26	25	24	23	22	21	20	19	18	17	16
	BDB31	BDB30	BDB29	BDB28	BDB27	BDB26	BDB25	BDB24	BDB23	BDB22	BDB21	BDB20	BDB19	BDB18	BDB17	BDB16
Initial value:	0	0	0	0	0	0	0	0	0	0	0	0	0	0	0	0
R/W:	R/W	R/W	R/W	R/W	R/W	R/W	R/W	R/W	R/W	R/W	R/W	R/W	R/W	R/W	R/W	R/W

Bit:	15	14	13	12	11	10	9	8	7	6	5	4	3	2	1	0
	BDB15	BDB14	BDB13	BDB12	BDB11	BDB10	BDB9	BDB8	BDB7	BDB6	BDB5	BDB4	BDB3	BDB2	BDB1	BDB0
Initial value:	0	0	0	0	0	0	0	0	0	0	0	0	0	0	0	0
R/W:	R/W	R/W	R/W	R/W	R/W	R/W	R/W	R/W	R/W	R/W	R/W	R/W	R/W	R/W	R/W	R/W

Bit	Bit Name	Initial Value	R/W	Description
31 to 0	BDB31 to BDB0	All 0	R/W	<p>Break Data Bit B</p> <p>Stores data which specifies a break condition in channel B.</p> <p>If the I bus is selected in BBRB, the break data on IDB is set in BDB31 to BDB0.</p> <p>If the L bus is selected in BBRB, the break data on LDB is set in BDB31 to BDB0.</p>

- Notes:
- Specify an operand size when including the value of the data bus in the break condition.
 - When the byte size is selected as a break condition, the same byte data must be set in bits 15 to 8 and 7 to 0 in BDRB as the break data.

7.3.9 Break Data Mask Register B (BDMRB) (F-ZTAT Version Only)

BDMRB is a 32-bit readable/writable register. BDMRB specifies bits masked in the break data specified by BDRB.

Bit:	31	30	29	28	27	26	25	24	23	22	21	20	19	18	17	16
	BDMB31	BDMB30	BDMB29	BDMB28	BDMB27	BDMB26	BDMB25	BDMB24	BDMB23	BDMB22	BDMB21	BDMB20	BDMB19	BDMB18	BDMB17	BDMB16
Initial value:	0	0	0	0	0	0	0	0	0	0	0	0	0	0	0	0
R/W:	R/W	R/W	R/W	R/W	R/W	R/W	R/W	R/W	R/W	R/W	R/W	R/W	R/W	R/W	R/W	R/W

Bit:	15	14	13	12	11	10	9	8	7	6	5	4	3	2	1	0
	BDMB15	BDMB14	BDMB13	BDMB12	BDMB11	BDMB10	BDMB9	BDMB8	BDMB7	BDMB6	BDMB5	BDMB4	BDMB3	BDMB2	BDMB1	BDMB0
Initial value:	0	0	0	0	0	0	0	0	0	0	0	0	0	0	0	0
R/W:	R/W	R/W	R/W	R/W	R/W	R/W	R/W	R/W	R/W	R/W	R/W	R/W	R/W	R/W	R/W	R/W

Bit	Bit Name	Initial Value	R/W	Description
31 to 0	BDMB31 to BDMB 0	All 0	R/W	<p>Break Data Mask B</p> <p>Specifies bits masked in the break data of channel B specified by BDRB (BDB31 to BDB0).</p> <p>0: Break data BDBn of channel B is included in the break condition</p> <p>1: Break data BDBn of channel B is masked and is not included in the break condition</p> <p>Note: n = 31 to 0</p>

- Notes:
1. Specify an operand size when including the value of the data bus in the break condition.
 2. When the byte size is selected as a break condition, the same byte data must be set in bits 15 to 8 and 7 to 0 in BDMRB as the break mask data in BDRB.

7.3.10 Break Bus Cycle Register B (BBRB)

BBRB is a 16-bit readable/writable register, which specifies (1) bus master for I bus cycle, (2) L bus cycle or I bus cycle, (3) instruction fetch or data access, (4) read or write, and (5) operand size in the break conditions of channel B.

Bit:	15	14	13	12	11	10	9	8	7	6	5	4	3	2	1	0
	-	-	-	-	-	CPB2*	CPB1*	CPB0*	CDB1*	CDB0	IDB1*	IDB0	RWB1*	RWB0	SZB1*	SZB0*
Initial value:	0	0	0	0	0	0	0	0	0	0	0	0	0	0	0	0
R/W:	R	R	R	R	R	R/W	R/W	R/W	R/W	R/W	R/W	R/W	R/W	R/W	R/W	R/W

Note: * In the masked ROM version, this bit is used as a reserved bit. This bit is always read as 0. The write value should always be 0.

Bit	Bit Name	Initial Value	R/W	Description
15 to 11	—	All 0	R	Reserved These bits are always read as 0. The write value should always be 0.
10	CPB2*	0	R/W	Bus Master Select B for I Bus
9	CPB1*	0	R/W	Select the bus master when the I bus is selected as the bus cycle of the channel B break condition.
8	CPB0*	0	R/W	However, when the L bus is selected as the bus cycle, the setting of the CPB2 to CPB0 bits is disabled. 000: Condition comparison is not performed xx1: The CPU cycle is included in the break condition x1x: Setting prohibited 1xx: The DTC cycle is included in the break condition
7	CDB1*	0	R/W	L Bus Cycle/I Bus Cycle Select B
6	CDB0	0	R/W	Select the L bus cycle or I bus cycle as the bus cycle of the channel B break condition. 00: Condition comparison is not performed 01: The break condition is the L bus cycle 10: The break condition is the I bus cycle 11: The break condition is the L bus cycle

Bit	Bit Name	Initial Value	R/W	Description
5	IDB1*	0	R/W	Instruction Fetch/Data Access Select B
4	IDB0	0	R/W	Select the instruction fetch cycle or data access cycle as the bus cycle of the channel B break condition. 00: Condition comparison is not performed 01: The break condition is the instruction fetch cycle 10: The break condition is the data access cycle 11: The break condition is the instruction fetch cycle or data access cycle
3	RWB1*	0	R/W	Read/Write Select B
2	RWB0	0	R/W	Select the read cycle or write cycle as the bus cycle of the channel B break condition. 00: Condition comparison is not performed 01: The break condition is the read cycle 10: The break condition is the write cycle 11: The break condition is the read cycle or write cycle
1	SZB1*	0	R/W	Operand Size Select B
0	SZB0*	0	R/W	Select the operand size of the bus cycle for the channel B break condition. 00: The break condition does not include operand size 01: The break condition is byte access 10: The break condition is word access 11: The break condition is longword access Note: When specifying the operand size, specify the size which matches the address boundary.

[Legend]

x: Don't care.

Note: * In the masked ROM version, these bits are reserved bits. They are always read as 0, and the write value should always be 0.

7.3.11 Break Control Register (BRCR)

BRCR sets the following conditions:

1. Channels A and B are used in two independent channel conditions or under the sequential condition.
2. A user break is set before or after instruction execution.
3. Specify whether to include the number of execution times on channel B in comparison conditions.
4. Determine whether to include data bus on channels A and B in comparison conditions.
5. Enable PC trace.
6. Select the \overline{UBCTRG} output pulse width.
7. Specify whether to request the user break interrupt when channels A and B match with comparison conditions.

BRCR is a 32-bit readable/writable register that has break conditions match flags and bits for setting a variety of break conditions.

Bit:	31	30	29	28	27	26	25	24	23	22	21	20	19	18	17	16
	-	-	-	-	-	-	-	-	-	-	UTRGW[1:0]	UBIDB	-	UBIDA	-	
Initial value:	0	0	0	0	0	0	0	0	0	0	0	0	0	0	0	0
R/W:	R	R	R	R	R	R	R	R	R	R	R/W	R/W	R/W	R	R/W	R

Bit:	15	14	13	12	11	10	9	8	7	6	5	4	3	2	1	0
	SCM FCA	SCM FCB	SCM FDA*	SCM FDB*	PCTE*	PCBA	-	-	DBEA*	PCBB	DBEB*	-	SEQ*	-	-	ETBE*
Initial value:	0	0	0	0	0	0	0	0	0	0	0	0	0	0	0	0
R/W:	R/W	R/W	R/W	R/W	R/W	R/W	R	R	R/W	R/W	R/W	R	R/W	R	R	R/W

Note: * In the masked ROM version, this bit is used as a reserved bit. This bit is always read as 0. The write value should always be 0.

Bit	Bit Name	Initial Value	R/W	Description
31 to 22	—	All 0	R	Reserved These bits are always read as 0. The write value should always be 0.
21, 20	UTRGW[1:0]	00	R/W	$\overline{\text{UBCTR}}\overline{\text{G}}$ Output Pulse Width Select Select the $\overline{\text{UBCTR}}\overline{\text{G}}$ output pulse width when the break condition matches. 00: Setting prohibited. 01: $\overline{\text{UBCTR}}\overline{\text{G}}$ output pulse width is 3 to 4 t_{Bcyc} 10: $\overline{\text{UBCTR}}\overline{\text{G}}$ output pulse width is 7 to 8 t_{Bcyc} 11: $\overline{\text{UBCTR}}\overline{\text{G}}$ output pulse width is 15 to 16 t_{Bcyc} Note: t_{Bcyc} indicates the period of one cycle of the external bus clock ($B\phi = \text{CK}$).
19	UBIDB	0	R/W	User Break Disable B Enables or disables the user break interrupt request when the channel B break conditions are satisfied. 0: User break interrupt request is enabled when break conditions are satisfied 1: User break interrupt request is disabled when break conditions are satisfied
18	—	0	R	Reserved This bit is always read as 0. The write value should always be 0.
17	UBIDA	0	R/W	User Break Disable A Enables or disables the user break interrupt request when the channel A break conditions are satisfied. 0: User break interrupt request is enabled when break conditions are satisfied 1: User break interrupt request is disabled when break conditions are satisfied
16	—	0	R	Reserved This bit is always read as 0. The write value should always be 0.

Bit	Bit Name	Initial Value	R/W	Description
15	SCMFCA	0	R/W	<p>L Bus Cycle Condition Match Flag A</p> <p>When the L bus cycle condition in the break conditions set for channel A is satisfied, this flag is set to 1. In order to clear this flag, write 0 into this bit.</p> <p>0: The L bus cycle condition for channel A does not match</p> <p>1: The L bus cycle condition for channel A matches</p>
14	SCMFCE	0	R/W	<p>L Bus Cycle Condition Match Flag B</p> <p>When the L bus cycle condition in the break conditions set for channel B is satisfied, this flag is set to 1. In order to clear this flag, write 0 into this bit.</p> <p>0: The L bus cycle condition for channel B does not match</p> <p>1: The L bus cycle condition for channel B matches</p>
13	SCMFDA*	0	R/W	<p>I Bus Cycle Condition Match Flag A</p> <p>When the I bus cycle condition in the break conditions set for channel A is satisfied, this flag is set to 1. In order to clear this flag, write 0 into this bit.</p> <p>0: The I bus cycle condition for channel A does not match</p> <p>1: The I bus cycle condition for channel A matches</p>
12	SCMFDB*	0	R/W	<p>I Bus Cycle Condition Match Flag B</p> <p>When the I bus cycle condition in the break conditions set for channel B is satisfied, this flag is set to 1. In order to clear this flag, write 0 into this bit.</p> <p>0: The I bus cycle condition for channel B does not match</p> <p>1: The I bus cycle condition for channel B matches</p>
11	PCTE*	0	R/W	<p>PC Trace Enable</p> <p>0: Disables PC trace</p> <p>1: Enables PC trace</p>

Bit	Bit Name	Initial Value	R/W	Description
10	PCBA	0	R/W	<p>PC Break Select A</p> <p>Selects the break timing of the instruction fetch cycle for channel A as before or after instruction execution.</p> <p>0: PC break of channel A is set before instruction execution</p> <p>1: PC break of channel A is set after instruction execution</p>
9, 8	—	All 0	R	<p>Reserved</p> <p>These bits are always read as 0. The write value should always be 0.</p>
7	DBEA*	0	R/W	<p>Data Break Enable A</p> <p>Selects whether or not the data bus condition is included in the break condition of channel A.</p> <p>0: No data bus condition is included in the condition of channel A</p> <p>1: The data bus condition is included in the condition of channel A</p>
6	PCBB	0	R/W	<p>PC Break Select B</p> <p>Selects the break timing of the instruction fetch cycle for channel B as before or after instruction execution.</p> <p>0: PC break of channel B is set before instruction execution</p> <p>1: PC break of channel B is set after instruction execution</p>
5	DBEB*	0	R/W	<p>Data Break Enable B</p> <p>Selects whether or not the data bus condition is included in the break condition of channel B.</p> <p>0: No data bus condition is included in the condition of channel B</p> <p>1: The data bus condition is included in the condition of channel B</p>
4	—	0	R	<p>Reserved</p> <p>This bit is always read as 0. The write value should always be 0.</p>

Bit	Bit Name	Initial Value	R/W	Description
3	SEQ*	0	R/W	Sequence Condition Select Selects two conditions of channels A and B as independent or sequential conditions. 0: Channels A and B are compared under independent conditions 1: Channels A and B are compared under sequential conditions (channel A, then channel B)
2, 1	—	All 0	R	Reserved These bits are always read as 0. The write value should always be 0.
0	ETBE*	0	R/W	Number of Execution Times Break Enable Enables the execution-times break condition only on channel B. If this bit is 1 (break enable), a user break interrupt is requested when the number of break conditions matches with the number of execution times that is specified by BETR. 0: The execution-times break condition is disabled on channel B 1: The execution-times break condition is enabled on channel B

Note: * In the masked ROM version, these bits are reserved bits. They are always read as 0, and the write value should always be 0.

7.3.12 Execution Times Break Register (BETR) (F-ZTAT Version Only)

BETR is a 16-bit readable/writable register. When the execution-times break condition of channel B is enabled, this register specifies the number of execution times to make the break. The maximum number is $2^{12} - 1$ times. When a break condition is satisfied, it decreases BETR. A user break interrupt is requested when the break condition is satisfied after BETR becomes H'0001.

Bit:	15	14	13	12	11	10	9	8	7	6	5	4	3	2	1	0
	-	-	-	-	BET[11:0]											
Initial value:	0	0	0	0	0	0	0	0	0	0	0	0	0	0	0	0
R/W:	R	R	R	R	R/W	R/W	R/W	R/W	R/W	R/W	R/W	R/W	R/W	R/W	R/W	R/W

Bit	Bit Name	Initial Value	R/W	Description
15 to 12	—	All 0	R	Reserved These bits are always read as 0. The write value should always be 0.
11 to 0	BET[11:0]	All 0	R/W	Number of Execution Times

7.3.13 Branch Source Register (BRSR) (F-ZTAT Version Only)

BRSR is a 32-bit read-only register. BRSR stores bits 27 to 0 in the address of the branch source instruction. BRSR has the flag bit that is set to 1 when a branch occurs. This flag bit is cleared to 0 when BRSR is read, the setting to enable PC trace is made, or BRSR is initialized by a power-on reset or manual reset. Other bits are not initialized by a reset. The eight BRSR registers have a queue structure and a stored register is shifted at every branch.

Bit:	31	30	29	28	27	26	25	24	23	22	21	20	19	18	17	16
	SVF	-	-	-	BSA27	BSA26	BSA25	BSA24	BSA23	BSA22	BSA21	BSA20	BSA19	BSA18	BSA17	BSA16
Initial value:	0	0	0	0	-	-	-	-	-	-	-	-	-	-	-	-
R/W:	R	R	R	R	R	R	R	R	R	R	R	R	R	R	R	R

Bit:	15	14	13	12	11	10	9	8	7	6	5	4	3	2	1	0
	BSA15	BSA14	BSA13	BSA12	BSA11	BSA10	BSA9	BSA8	BSA7	BSA6	BSA5	BSA4	BSA3	BSA2	BSA1	BSA0
Initial value:	-	-	-	-	-	-	-	-	-	-	-	-	-	-	-	-
R/W:	R	R	R	R	R	R	R	R	R	R	R	R	R	R	R	R

Bit	Bit Name	Initial Value	R/W	Description
31	SVF	0	R	BRSR Valid Flag Indicates whether the branch source address is stored. This flag bit is set to 1 when a branch occurs. This flag is cleared to 0 when BRSR is read, the setting to enable PC trace is made, or BRSR is initialized by a power-on reset. 0: The value of BRSR register is invalid 1: The value of BRSR register is valid
30 to 28	—	All 0	R	Reserved These bits are always read as 0. The write value should always be 0.
27 to 0	BSA27 to BSA0	Undefined	R	Branch Source Address Store bits 27 to 0 of the branch source address.

7.3.14 Branch Destination Register (BRDR) (F-ZTAT Version Only)

BRDR is a 32-bit read-only register. BRDR stores bits 27 to 0 in the address of the branch destination instruction. BRDR has the flag bit that is set to 1 when a branch occurs. This flag bit is cleared to 0 when BRDR is read, the setting to enable PC trace is made, or BRDR is initialized by a power-on reset or manual reset. Other bits are not initialized by a reset. The eight BRDR registers have a queue structure and a stored register is shifted at every branch.

Bit:	31	30	29	28	27	26	25	24	23	22	21	20	19	18	17	16
	DVF	-	-	-	BDA27	BDA26	BDA25	BDA24	BDA23	BDA22	BDA21	BDA20	BDA19	BDA18	BDA17	BDA16
Initial value:	0	0	0	0	-	-	-	-	-	-	-	-	-	-	-	-
R/W:	R	R	R	R	R	R	R	R	R	R	R	R	R	R	R	R

Bit:	15	14	13	12	11	10	9	8	7	6	5	4	3	2	1	0
	BDA15	BDA14	BDA13	BDA12	BDA11	BDA10	BDA9	BDA8	BDA7	BDA6	BDA5	BDA4	BDA3	BDA2	BDA1	BDA0
Initial value:	-	-	-	-	-	-	-	-	-	-	-	-	-	-	-	-
R/W:	R	R	R	R	R	R	R	R	R	R	R	R	R	R	R	R

Bit	Bit Name	Initial Value	R/W	Description
31	DVF	0	R	BRDR Valid Flag Indicates whether a branch destination address is stored. This flag bit is set to 1 when a branch occurs. This flag is cleared to 0 when BRDR is read, the setting to enable PC trace is made, or BRDR is initialized by a power-on reset. 0: The value of BRDR register is invalid 1: The value of BRDR register is valid
30 to 28	—	All 0	R	Reserved These bits are always read as 0. The write value should always be 0.
27 to 0	BDA27 to BDA0	Undefined	R	Branch Destination Address Store bits 27 to 0 of the branch destination address.

7.4 Operation

7.4.1 Flow of the User Break Operation

The flow from setting of break conditions to user break exception processing is described below:

1. The break addresses are set in the break address registers (BARA or BARB). The masked addresses are set in the break address mask registers (BAMRA or BAMRB). The break data is set in the break data register (BDRA or BDRB). The masked data is set in the break data mask register (BDMRA or BDMRB). The bus break conditions are set in the break bus cycle registers (BBRA or BBRB). Three groups of BBRA or BBRB (L bus cycle/I bus cycle select, instruction fetch/data access select, and read/write select) are each set. No user break will be generated if even one of these groups is set with B'00. The respective conditions are set in the bits of the break control register (BRCR). Make sure to set all registers related to breaks before setting BBRA or BBRB.
2. When the break conditions are satisfied, the UBC sends a user break interrupt request to the CPU and sets the L bus condition match flag (SCMFCA or SCMFCE) and the I bus condition match flag (SCMFDA or SCMFDE) for the appropriate channel.
3. The appropriate condition match flags (SCMFCA, SCMFCE, SCMFDA, and SCMFDE) can be used to check if the set conditions match or not. The matching of the conditions sets flags, but they are not reset. Before using them again, 0 must first be written to them and then reset flags.
4. There is a chance that matches of the break conditions set in channels A and B occur almost at the same time. In this case, there will be only one user break request to the CPU, but these two conditions match flags could be both set.
5. When selecting the I bus as the break condition, note the following:
 - The CPU and DTC are connected to the I bus. The UBC monitors bus cycles generated by all bus masters that are selected by the CPA2 to CPA0 bits in BBRA or the CPB2 to CPB0 bits in BBRB, and compares the conditions for a match.
 - I bus cycles (including read fill cycles) resulting from instruction fetches on the L bus by the CPU are defined as instruction fetch cycles on the I bus, while other bus cycles are defined as data access cycles.
 - The DTC only issue data access cycles for I bus cycles.
 - If a break condition is specified for the I bus, even when the condition matches in an I bus cycle resulting from an instruction executed by the CPU, at which instruction the user break is to be accepted cannot be clearly defined.

7.4.2 User Break on Instruction Fetch Cycle

1. When L bus/instruction fetch/read/word, longword, or not including the operand size is set in the break bus cycle register (BBRA or BBRB), the break condition becomes the L bus instruction fetch cycle. Whether it breaks before or after the execution of the instruction can then be selected with the PCBA or PCBB bit in the break control register (BRCR) for the appropriate channel. If an instruction fetch cycle is set as a break condition, clear LSB in the break address register (BARA or BARB) to 0. A user break cannot be generated as long as this bit is set to 1.
2. If the break condition matches when a user break on instruction fetch is specified so that the a break is generated before the execution of the instruction, the user break is generated at the point when it has become deterministic that the instruction will be executed after it is fetched. This means this feature cannot be used on instructions fetched by overrun (instructions fetched at a branch or during an interrupt transition, but not to be executed). When this kind of break condition is set for the delay slot of a delayed branch instruction, the user break is generated prior to execution of the delayed branch instruction.

Note: If a branch does not occur at a delay condition branch instruction, the subsequent instruction is not recognized as a delay slot.
3. When the break condition is specified so that a user break is generated after execution of the instruction, the instruction that has met the break condition is executed and then the user break is generated before the next instruction is executed. As with pre-execution user breaks, this cannot be used with overrun fetch instructions. When this kind of break condition is set for a delayed branch instruction and its delay slot, a user break is not generated until the first instruction at the branch destination.
4. When an instruction fetch cycle is set, the break data register (BDRA or BDRB) is ignored. Therefore, break data cannot be set for the user break of the instruction fetch cycle.
5. If the I bus is set for a user break of an instruction fetch cycle, the condition is determined for the instruction fetch cycles on the I bus. For details, see 5 in section 7.4.1, Flow of the User Break Operation.

7.4.3 User Break on Data Access Cycle

1. If the L bus is specified as a break condition for data access break, condition comparison is performed for the address (and data) accessed by the executed instructions, and a user break occurs if the condition is satisfied. If the I bus is specified as a break condition, condition comparison is performed for the addresses (and data) of the data access cycles that are issued on the I bus by all bus masters including the CPU, and a user break occurs if the condition is satisfied. For details on the CPU bus cycles issued on the I bus, see 5 in section 7.4.1, Flow of the User Break Operation.
2. The relationship between the data access cycle address and the comparison condition for each operand size is listed in table 7.3.

Table 7.3 Data Access Cycle Addresses and Operand Size Comparison Conditions

Access Size	Address Compared
Longword	Compares break address register bits 31 to 2 to address bus bits 31 to 2
Word	Compares break address register bits 31 to 1 to address bus bits 31 to 1
Byte	Compares break address register bits 31 to 0 to address bus bits 31 to 0

This means that when address H'00001003 is set in the break address register (BARA or BARB), for example, the bus cycle in which the break condition is satisfied is as follows (where other conditions are met).

Longword access at H'00001000

Word access at H'00001002

Byte access at H'00001003

3. When the data value is included in the break conditions:

When the data value is included in the break conditions, either longword, word, or byte is specified as the operand size of the break bus cycle register (BBRA or BBRB). When data values are included in break conditions, a user break is generated when the address conditions and data conditions both match. To specify byte data for this case, set the same data in two bytes at bits 15 to 8 and bits 7 to 0 of the break data register (BDRA or BDRB) and break data mask register (BDMRA or BDMRB). When word or byte is set, bits 31 to 16 of BDRA or BDRB and BDMRA or BDMRB are ignored.
4. If the L bus is selected, a user break occurs on ending execution of the instruction that matches the break condition, and immediately before the next instruction is executed. However, when data is also specified as the break condition, the break may occur on ending execution of the instruction following the instruction that matches the break condition. If the I bus is selected, the instruction at which the user break will occur cannot be determined. When this kind of user

break occurs at a delayed branch instruction or its delay slot, the user break may not actually take place until the first instruction at the branch destination.

7.4.4 Sequential Break

1. By setting the SEQ bit in BRCCR to 1, the sequential break is issued when a channel B break condition matches after a channel A break condition matches. A user break is not generated even if a channel B break condition matches before a channel A break condition matches. When channels A and B conditions match at the same time, the sequential break is not issued. To clear the channel A condition match when a channel A condition match has occurred but a channel B condition match has not yet occurred in a sequential break specification, clear the SEQ bit in BRCCR to 0 and clear the condition match flag to 0 in channel A.
2. In sequential break specification, the L or I bus can be selected and the execution times break condition can be also specified. For example, when the execution times break condition is specified, the break condition is satisfied when a channel B condition matches with BETR = H'0001 after a channel A condition has matched.

7.4.5 Value of Saved Program Counter

When a user break occurs, the address of the instruction from where execution is to be resumed is saved in the stack, and the exception handling state is entered. If the L bus is specified as a break condition, the instruction at which the user break should occur can be clearly determined (except for when data is included in the break condition). If the I bus is specified as a break condition, the instruction at which the user break should occur cannot be clearly determined.

1. When instruction fetch (before instruction execution) is specified as a break condition:
The address of the instruction that matched the break condition is saved in the stack. The instruction that matched the condition is not executed, and the user break occurs before it. However when a delay slot instruction matches the condition, the address of the delayed branch instruction is saved in the stack.
2. When instruction fetch (after instruction execution) is specified as a break condition:
The address of the instruction following the instruction that matched the break condition is saved in the stack. The instruction that matches the condition is executed, and the user break occurs before the next instruction is executed. However when a delayed branch instruction or delay slot matches the condition, these instructions are executed, and the branch destination address is saved in the stack.

3. When data access (address only) is specified as a break condition:

The address of the instruction immediately after the instruction that matched the break condition is saved in the stack. The instruction that matches the condition is executed, and the user break occurs before the next instruction is executed. However when a delay slot instruction matches the condition, the branch destination address is saved in the stack.

4. When data access (address + data) is specified as a break condition:

When a data value is added to the break conditions, the address of an instruction that is within two instructions of the instruction that matched the break condition is saved in the stack. At which instruction the user break occurs cannot be determined accurately.

When a delay slot instruction matches the condition, the branch destination address is saved in the stack. If the instruction following the instruction that matches the break condition is a branch instruction, the user break may occur after the branch instruction or delay slot has finished. In this case, the branch destination address is saved in the stack.

7.4.6 PC Trace

1. Setting PCTE in BRCCR to 1 enables PC traces. When branch (branch instruction, and interrupt exception) is generated, the branch source address and branch destination address are stored in BRSR and BRDR, respectively.
2. The values stored in BRSR and BRDR are as given below due to the kind of branch.
 - If a branch occurs due to a branch instruction, the address of the branch instruction is saved in BRSR and the address of the branch destination instruction is saved in BRDR.
 - If a branch occurs due to an interrupt or exception, the value saved in stack due to exception occurrence is saved in BRSR and the start address of the exception handling routine is saved in BRDR.
3. BRSR and BRDR have eight pairs of queue structures. The top of queues is read first when the address stored in the PC trace register is read. BRSR and BRDR share the read pointer. Read BRSR and BRDR in order, the queue only shifts after BRDR is read. After switching the PCTE bit (in BRCCR) off and on, the values in the queues are invalid.
4. Since eight pairs of queue are shared with the AUD, set the PCTE bit in BRCCR to 1 after setting the MSTP25 bit in STBCR5 to 0 and the AUDSRST bit in STBCR6 to 1. Although the AUD is only available in the F-ZTAT version supporting full functions of the E10A, this setting should also be made in the normal F-ZTAT version.

7.4.7 Usage Examples

Break Condition Specified for L Bus Instruction Fetch Cycle:

(Example 1-1)

- Register specifications

BARA = H'00000404, BAMRA = H'00000000, BBRA = H'0054, BDRA = H'00000000,
BDMRA = H'00000000, BARB = H'00008010, BAMRB = H'00000006, BBRB = H'0054,
BDRB = H'00000000, BDMRB = H'00000000, BR CR = H'00000400

Specified conditions: Channel A/channel B independent mode

<Channel A>

Address: H'00000404, Address mask: H'00000000

Data: H'00000000, Data mask: H'00000000

Bus cycle: L bus/instruction fetch (after instruction execution)/read (operand size is not included in the condition)

<Channel B>

Address: H'00008010, Address mask: H'00000006

Data: H'00000000, Data mask: H'00000000

Bus cycle: L bus/instruction fetch (before instruction execution)/read (operand size is not included in the condition)

A user break occurs after an instruction of address H'00000404 is executed or before instructions of addresses H'00008010 to H'00008016 are executed.

(Example 1-2)

- Register specifications

BARA = H'00037226, BAMRA = H'00000000, BBRA = H'0056, BDRA = H'00000000,
BDMRA = H'00000000, BARB = H'0003722E, BAMRB = H'00000000, BBRB = H'0056,
BDRB = H'00000000, BDMRB = H'00000000, BR CR = H'00000008

Specified conditions: Channel A/channel B sequential mode

<Channel A>

Address: H'00037226, Address mask: H'00000000

Data: H'00000000, Data mask: H'00000000

Bus cycle: L bus/instruction fetch (before instruction execution)/read/word

<Channel B>

Address: H'0003722E, Address mask: H'00000000

Data: H'00000000, Data mask: H'00000000

Bus cycle: L bus/instruction fetch (before instruction execution)/read/word

After an instruction with address H'00037226 is executed, a user break occurs before an instruction with address H'0003722E is executed.

(Example 1-3)

- Register specifications

BARA = H'00027128, BAMRA = H'00000000, BBRA = H'005A, BDRA = H'00000000,
BDMRA = H'00000000, BARB = H'00031415, BAMRB = H'00000000, BBRB = H'0054,
BDRB = H'00000000, BDMRB = H'00000000, BR CR = H'00000000

Specified conditions: Channel A/channel B independent mode

<Channel A>

Address: H'00027128, Address mask: H'00000000

Data: H'00000000, Data mask: H'00000000

Bus cycle: L bus/instruction fetch (before instruction execution)/write/word

<Channel B>

Address: H'00031415, Address mask: H'00000000

Data: H'00000000, Data mask: H'00000000

Bus cycle: L bus/instruction fetch (before instruction execution)/read (operand size is not included in the condition)

On channel A, no user break occurs since instruction fetch is not a write cycle. On channel B, no user break occurs since instruction fetch is performed for an even address.

(Example 1-4)

- Register specifications

BARA = H'00037226, BAMRA = H'00000000, BBRA = H'005A, BDRA = H'00000000,
BDMRA = H'00000000, BARB = H'0003722E, BAMRB = H'00000000, BBRB = H'0056,
BDRB = H'00000000, BDMRB = H'00000000, BR CR = H'00000008

Specified conditions: Channel A/channel B sequential mode

<Channel A>

Address: H'00037226, Address mask: H'00000000

Data: H'00000000, Data mask: H'00000000

Bus cycle: L bus/instruction fetch (before instruction execution)/write/word

<Channel B>

Address: H'0003722E, Address mask: H'00000000

Data: H'00000000, Data mask: H'00000000

Bus cycle: L bus/instruction fetch (before instruction execution)/read/word

Since instruction fetch is not a write cycle on channel A, a sequential condition does not match. Therefore, no user break occurs.

(Example 1-5)

- Register specifications

BARA = H'00000500, BAMRA = H'00000000, BBRA = H'0057, BDRA = H'00000000,
BDMRA = H'00000000, BARB = H'00001000, BAMRB = H'00000000, BBRB = H'0057,
BDRB = H'00000000, BDMRB = H'00000000, BR CR = H'00000001, BETR = H'0005

Specified conditions: Channel A/channel B independent mode

<Channel A>

Address: H'00000500, Address mask: H'00000000

Data: H'00000000, Data mask: H'00000000

Bus cycle: L bus/instruction fetch (before instruction execution)/read/longword

The number of execution-times break enable (5 times)

<Channel B>

Address: H'00001000, Address mask: H'00000000

Data: H'00000000, Data mask: H'00000000

Bus cycle: L bus/instruction fetch (before instruction execution)/read/longword

On channel A, a user break occurs after the instruction of address H'00000500 is executed four times and before the fifth time.

On channel B, a user break occurs before an instruction of address H'00001000 is executed.

(Example 1-6)

- Register specifications

BARA = H'00008404, BAMRA = H'0000FFF, BBRA = H'0054, BDRA = H'00000000,
BDMRA = H'00000000, BARB = H'00008010, BAMRB = H'00000006, BBRB = H'0054,
BDRB = H'00000000, BDMRB = H'00000000, BR CR = H'00000400

Specified conditions: Channel A/channel B independent mode

<Channel A>

Address: H'00008404, Address mask: H'0000FFF

Data: H'00000000, Data mask: H'00000000

Bus cycle: L bus/instruction fetch (after instruction execution)/read (operand size is not included in the condition)

<Channel B>

Address: H'00008010, Address mask: H'00000006

Data: H'00000000, Data mask: H'00000000

Bus cycle: L bus/instruction fetch (before instruction execution)/read (operand size is not included in the condition)

A user break occurs after an instruction with addresses H'00008000 to H'00008FFE is executed or before an instruction with addresses H'00008010 to H'00008016 are executed.

Break Condition Specified for L Bus Data Access Cycle:

(Example 2-1)

- Register specifications

BARA = H'00123456, BAMRA = H'00000000, BBRA = H'0064, BDRA = H'12345678,
BDMRA = H'FFFFFFFF, BARB = H'000ABCDE, BAMRB = H'000000FF, BBRB = H'006A,
BDRB = H'0000A512, BDMRB = H'00000000, BRBR = H'00000080

Specified conditions: Channel A/channel B independent mode

<Channel A>

Address: H'00123456, Address mask: H'00000000

Data: H'12345678, Data mask: H'FFFFFFFF

Bus cycle: L bus/data access/read (operand size is not included in the condition)

<Channel B>

Address: H'000ABCDE, Address mask: H'000000FF

Data: H'0000A512, Data mask: H'00000000

Bus cycle: L bus/data access/write/word

On channel A, a user break occurs with longword read from address H'00123454, word read from address H'00123456, or byte read from address H'00123456. On channel B, a user break occurs when word H'A512 is written in addresses H'000ABC00 to H'000ABCFE.

Break Condition Specified for I Bus Data Access Cycle:

(Example 3-1)

• Register specifications

BARA = H'00314154, BAMRA = H'00000000, BBRA = H'0194, BDRA = H'12345678,
BDMRA = H'FFFFFFFF, BARB = H'00055555, BAMRB = H'00000000, BBRB = H'01A9,
BDRB = H'00007878, BDMRB = H'0000F0F, BR CR = H'00000080

Specified conditions: Channel A/channel B independent mode

<Channel A>

Address: H'00314154, Address mask: H'00000000

Data: H'12345678, Data mask: H'FFFFFFFF

Bus cycle: I bus (CPU cycle)/instruction fetch/read (operand size is not included in the condition)

<Channel B>

Address: H'00055555, Address mask: H'00000000

Data: H'00000078, Data mask: H'0000000F

Bus cycle: I bus (CPU cycle)/data access/write/byte

On channel A, a user break occurs when instruction fetch is performed for address H'00314156 in the external memory space.

On channel B, a user break occurs when byte data H'7x is written in address H'00055555 in the external memory space by the CPU.

7.5 Usage Notes

1. The CPU can read from or write to the UBC registers via the I bus. Accordingly, during the period from executing an instruction to rewrite the UBC register till the new value is actually rewritten, the desired user break may not occur. In order to know the timing when the UBC register is changed, read from the last written register. Instructions after then are valid for the newly written register value.
2. UBC cannot monitor access to the L bus and I bus in the same channel.
3. Note on specification of sequential break:

A condition match occurs when a B-channel match occurs in a bus cycle after an A-channel match occurs in another bus cycle in sequential break setting. Therefore, no user break occurs even if a bus cycle, in which an A-channel match and a channel B match occur simultaneously, is set.
4. When a user break and another exception occur at the same instruction, which has higher priority is determined according to the priority levels defined in table 5.1 in section 5, Exception Handling. If an exception with higher priority occurs, the user break is not generated.
 - Pre-execution break has the highest priority.
 - When a post-execution break or data access break occurs simultaneously with a re-execution-type exception (including pre-execution break) that has higher priority, the re-execution-type exception is accepted, and the condition match flag is not set (see the exception in the following note). The user break will occur and the condition match flag will be set only after the exception source of the re-execution-type exception has been cleared by the exception handling routine and re-execution of the same instruction has ended.
 - When a post-execution break or data access break occurs simultaneously with a completion-type exception (TRAPA) that has higher priority, though a user break does not occur, the condition match flag is set.
5. Note the following exception for the above note.

If a post-execution break or data access break is satisfied by an instruction that generates a CPU address error by data access, the CPU address error is given priority to the user break interrupt. Note that the UBC condition match flag is set in this case.
6. Note the following when a user break occurs in a delay slot.

If a pre-execution break is set at the delay slot instruction of the RTE instruction, the user break does not occur until the branch destination of the RTE instruction.
7. User breaks are disabled during UBC module standby mode. Do not read from or write to the UBC registers during UBC module standby mode; the values are not guaranteed.

8. Do not set a post-execution break at a SLEEP instruction or a branch instruction for which a SLEEP instruction is placed in the delay slot. In addition, do not set a data access break at a SLEEP instruction or one or two instructions before a SLEEP instruction.
9. When the DTC or DMAC is in operation, the UBC cannot correctly determine access to the external space by the CPU via the I bus. To determine access to the external space via the I bus in the above situation, select all bus masters. This makes it impossible to determine conditions of access with specified bus masters. However, when a bus master can be inferred from data values, the relevant data values can be included as a condition that indicates a particular bus master.

Section 8 Data Transfer Controller (DTC)

This LSI includes a data transfer controller (DTC). The DTC can be activated to transfer data by an interrupt request.

8.1 Features

- Transfer possible over any number of channels:
- Chain transfer
Multiple rounds of data transfer is executed in response to a single activation source
Chain transfer is only possible after data transfer has been done for the specified number of times (i.e. when the transfer counter is 0)
- Three transfer modes
Normal/repeat/block transfer modes selectable
Transfer source and destination addresses can be selected from increment/decrement/fixd
- The transfer source and destination addresses can be specified by 32 bits to select a 4-Gbyte address space directly
- Size of data for data transfer can be specified as byte, word, or longword
- A CPU interrupt can be requested for the interrupt that activated the DTC
A CPU interrupt can be requested after one data transfer completion
A CPU interrupt can be requested after the specified data transfer completion
- Read skip of the transfer information specifiable
- Writeback skip executed for the fixed transfer source and destination addresses
- Module stop mode specifiable
- Short address mode specifiable
- Bus release timing selectable from five types
- Priority of the DTC activation selectable from two types

Figure 8.1 shows a block diagram of the DTC. The DTC transfer information can be allocated to the data area*.

Note: * When the transfer information is stored in the on-chip RAM, the RAME bit in RAMCR must be set to 1.

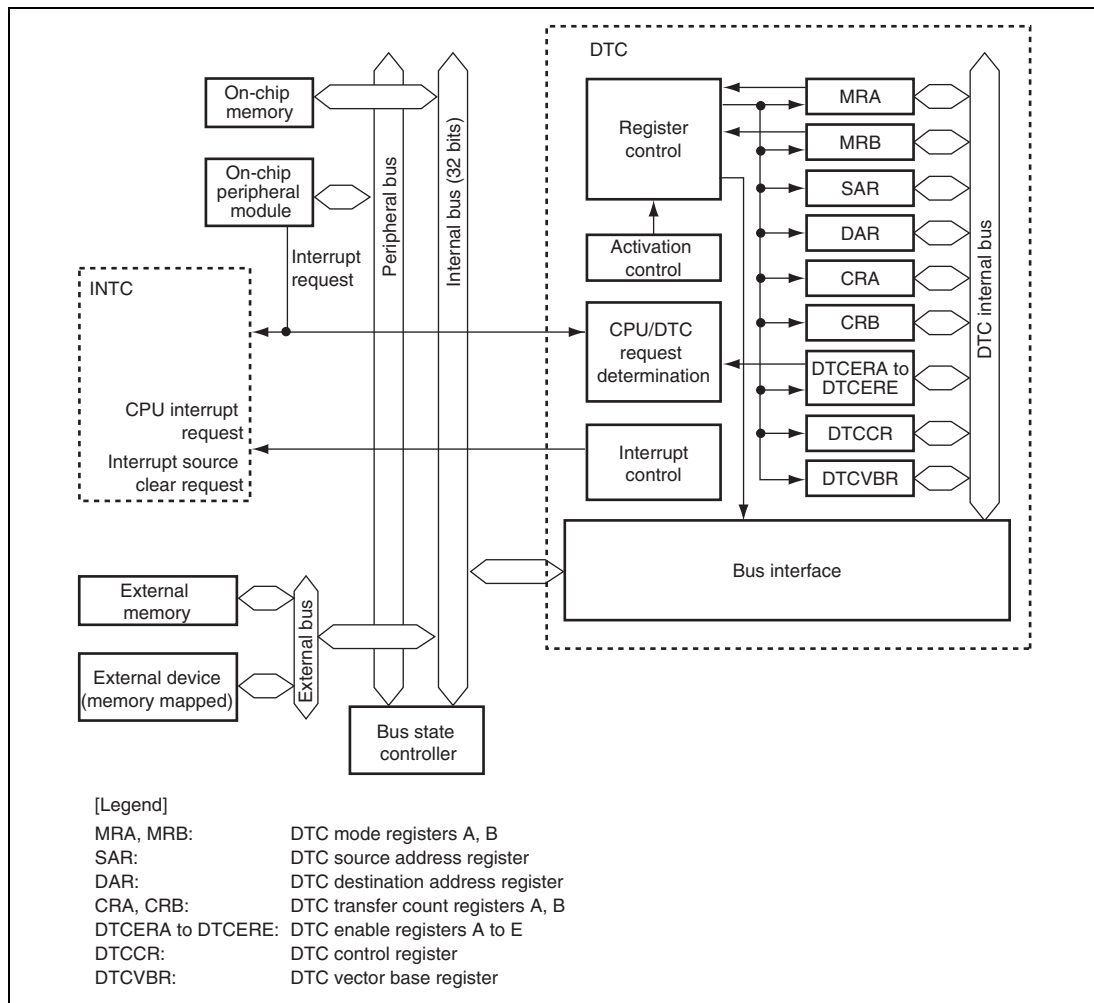

Figure 8.1 Block Diagram of DTC

8.2 Register Descriptions

DTC has the following registers. For details on the addresses of these registers and the states of these registers in each processing state, see section 23, List of Registers.

These six registers MRA, MRB, SAR, DAR, CRA, and CRB cannot be directly accessed by the CPU. The contents of these registers are stored in the data area as transfer information. When a DTC activation request occurs, the DTC reads a start address of transfer information that is stored in the data area according to the vector address, reads the transfer information, and transfers data. After the data transfer, it writes a set of updated transfer information back to the data area.

On the other hand, DTCERA to DTCERE, DTCCR, and DTCVBR can be directly accessed by the CPU.

Table 8.1 Register Configuration

Register Name	Abbreviation	R/W	Initial Value	Address	Access Size
DTC enable register A	DTCERA	R/W	H'0000	H'FFFCC80	8, 16
DTC enable register B	DTCERB	R/W	H'0000	H'FFFCC82	8, 16
DTC enable register C	DTCERC	R/W	H'0000	H'FFFCC84	8, 16
DTC enable register D	DTCERD	R/W	H'0000	H'FFFCC86	8, 16
DTC enable register E	DTCERE	R/W	H'0000	H'FFFCC88	8, 16
DTC control register	DTCCR	R/W	H'00	H'FFFCC90	8
DTC vector base register	DTCVBR	R/W	H'00000000	H'FFFCC94	8, 16, 32
Bus function extending register	BSCEHR	R/W	H'0000	H'FFF89A	8, 16

8.2.1 DTC Mode Register A (MRA)

MRA selects DTC operating mode. MRA cannot be accessed directly by the CPU.

Bit:	7	6	5	4	3	2	1	0
	MD[1:0]		Sz[1:0]		SM[1:0]		-	-
Initial value:	-	-	-	-	-	-	-	-
R/W:	-	-	-	-	-	-	-	-

Bit	Bit Name	Initial Value	R/W	Description
7, 6	MD[1:0]	Undefined	—	DTC Mode 1 and 0 Specify DTC transfer mode. 00: Normal mode 01: Repeat mode 10: Block transfer mode 11: Setting prohibited
5, 4	Sz[1:0]	Undefined	—	DTC Data Transfer Size 1 and 0 Specify the size of data to be transferred. 00: Byte-size transfer 01: Word-size transfer 10: Longword-size transfer 11: Setting prohibited
3, 2	SM[1:0]	Undefined	—	Source Address Mode 1 and 0 Specify an SAR operation after a data transfer. 0x: SAR is fixed (SAR writeback is skipped) 10: SAR is incremented after a transfer (by 1 when Sz1 and Sz0 = B'00; by 2 when Sz1 and Sz0 = B'01; by 4 when Sz1 and Sz0 = B'10) 11: SAR is decremented after a transfer (by 1 when Sz1 and Sz0 = B'00; by 2 when Sz1 and Sz0 = B'01; by 4 when Sz1 and Sz0 = B'10)

Bit	Bit Name	Initial Value	R/W	Description
1, 0	—	Undefined	—	Reserved The write value should always be 0.

[Legend]

x: Don't care

8.2.2 DTC Mode Register B (MRB)

MRB selects DTC operating mode. MRB cannot be accessed directly by the CPU.

Bit:	7	6	5	4	3	2	1	0
	CHNE	CHNS	DISEL	DTS	DM[1:0]	-	-	-
Initial value:	-	-	-	-	-	-	-	-
R/W:	-	-	-	-	-	-	-	-

Bit	Bit Name	Initial Value	R/W	Description
7	CHNE	Undefined	—	DTC Chain Transfer Enable Specifies the chain transfer. For details, see section 8.5.6, Chain Transfer. The chain transfer condition is selected by the CHNS bit. 0: Disables the chain transfer 1: Enables the chain transfer
6	CHNS	Undefined	—	DTC Chain Transfer Select Specifies the chain transfer condition. If the following transfer is a chain transfer, the completion check of the specified transfer count is not performed and activation source flag or DTCER is not cleared. 0: Chain transfer every time 1: Chain transfer only when transfer counter = 0

Bit	Bit Name	Initial Value	R/W	Description
5	DISEL	Undefined	—	<p>DTC Interrupt Select</p> <p>When this bit is set to 1, an interrupt request is generated to the CPU every time a data transfer or a block transfer ends. When this bit is set to 0, a CPU interrupt request is only generated when the specified number of data transfers end.</p>
4	DTS	Undefined	—	<p>DTC Transfer Mode Select</p> <p>Specifies either the source or destination as repeat or block area during repeat or block transfer mode.</p> <p>0: Specifies the destination as repeat or block area</p> <p>1: Specifies the source as repeat or block area</p>
3, 2	DM[1:0]	Undefined	—	<p>Destination Address Mode 1 and 0</p> <p>Specify a DAR operation after a data transfer.</p> <p>0x: DAR is fixed (DAR writeback is skipped)</p> <p>10: DAR is incremented after a transfer (by 1 when Sz1 and Sz0 = B'00; by 2 when Sz1 and Sz0 = B'01; by 4 when Sz1 and Sz0 = B'10)</p> <p>11: SAR is decremented after a transfer (by 1 when Sz1 and Sz0 = B'00; by 2 when Sz1 and Sz0 = B'01; by 4 when Sz1 and Sz0 = B'10)</p>
1, 0	—	Undefined	—	<p>Reserved</p> <p>The write value should always be 0.</p>

[Legend]

x: Don't care

8.2.3 DTC Source Address Register (SAR)

SAR is a 32-bit register that designates the source address of data to be transferred by the DTC.

SAR cannot be accessed directly from the CPU.

Bit:	31	30	29	28	27	26	25	24	23	22	21	20	19	18	17	16
Initial value:	*	*	*	*	*	*	*	*	*	*	*	*	*	*	*	*
R/W:	-	-	-	-	-	-	-	-	-	-	-	-	-	-	-	-
Bit:	15	14	13	12	11	10	9	8	7	6	5	4	3	2	1	0
Initial value:	*	*	*	*	*	*	*	*	*	*	*	*	*	*	*	*
R/W:	-	-	-	-	-	-	-	-	-	-	-	-	-	-	-	-

*: Undefined

8.2.4 DTC Destination Address Register (DAR)

DAR is a 32-bit register that designates the destination address of data to be transferred by the DTC.

DAR cannot be accessed directly from the CPU.

Bit:	31	30	29	28	27	26	25	24	23	22	21	20	19	18	17	16
Initial value:	*	*	*	*	*	*	*	*	*	*	*	*	*	*	*	*
R/W:	-	-	-	-	-	-	-	-	-	-	-	-	-	-	-	-
Bit:	15	14	13	12	11	10	9	8	7	6	5	4	3	2	1	0
Initial value:	*	*	*	*	*	*	*	*	*	*	*	*	*	*	*	*
R/W:	-	-	-	-	-	-	-	-	-	-	-	-	-	-	-	-

*: Undefined

8.2.5 DTC Transfer Count Register A (CRA)

CRA is a 16-bit register that designates the number of times data is to be transferred by the DTC.

In normal transfer mode, CRA functions as a 16-bit transfer counter (1 to 65,536). It is decremented by 1 every time data is transferred, and bit DTCE_n (n = 15 to 0) corresponding to the activation source is cleared and then an interrupt is requested to the CPU when the count reaches H'0000. The transfer count is 1 when CRA = H'0001, 65,535 when CRA = H'FFFF, and 65,536 when CRA = H'0000.

In repeat transfer mode, CRA is divided into two parts: the upper eight bits (CRAH) and the lower eight bits (CRAL). CRAH holds the number of transfers while CRAL functions as an 8-bit transfer counter (1 to 256). CRAL is decremented by 1 every time data is transferred, and the contents of CRAH are sent to CRAL when the count reaches H'00. The transfer count is 1 when CRAH = CRAL = H'01, 255 when CRAH = CRAL = H'FF, and 256 when CRAH = CRAL = H'00.

In block transfer mode, CRA is divided into two parts: the upper eight bits (CRAH) and the lower eight bits (CRAL). CRAH holds the block size while CRAL functions as an 8-bit block-size counter (1 to 256 for byte, word, or longword). CRAL is decremented by 1 every time a byte (word or longword) data is transferred, and the contents of CRAH are sent to CRAL when the count reaches H'00. The block size is 1 byte (word or longword) when CRAH = CRAL = H'01, 255 bytes (words or longwords) when CRAH = CRAL = H'FF, and 256 bytes (words or longwords) when CRAH = CRAL = H'00.

CRA cannot be accessed directly from the CPU.

Bit:	15	14	13	12	11	10	9	8	7	6	5	4	3	2	1	0
Initial value:	*	*	*	*	*	*	*	*	*	*	*	*	*	*	*	*
R/W:	-	-	-	-	-	-	-	-	-	-	-	-	-	-	-	-

*: Undefined

8.2.6 DTC Transfer Count Register B (CRB)

CRB is a 16-bit register that designates the number of times data is to be transferred by the DTC in block transfer mode. It functions as a 16-bit transfer counter (1 to 65,536) that is decremented by 1 every time a block of data is transferred, and bit DTCE_n (n = 15 to 0) corresponding to the activation source is cleared and then an interrupt is requested to the CPU when the count reaches H'0000. The transfer count is 1 when CRB = H'0001, 65,535 when CRB = H'FFFF, and 65,536 when CRB = H'0000.

CRB is not available in normal and repeat modes and cannot be accessed directly by the CPU.

Bit:	15	14	13	12	11	10	9	8	7	6	5	4	3	2	1	0
Initial value:	*	*	*	*	*	*	*	*	*	*	*	*	*	*	*	*
R/W:	-	-	-	-	-	-	-	-	-	-	-	-	-	-	-	-

*: Undefined

8.2.7 DTC Enable Registers A to E (DTCERA to DTCERE)

DTCER which is comprised of eight registers, DTCERA to DTCERE, is a register that specifies DTC activation interrupt sources. The correspondence between interrupt sources and DTCE bits is shown in table 8.2.

Bit:	15	14	13	12	11	10	9	8	7	6	5	4	3	2	1	0
	DTCE15	DTCE14	DTCE13	DTCE12	DTCE11	DTCE10	DTCE9	DTCE8	DTCE7	DTCE6	DTCE5	DTCE4	DTCE3	DTCE2	DTCE1	DTCE0
Initial value:	0	0	0	0	0	0	0	0	0	0	0	0	0	0	0	0
R/W:	R/W	R/W	R/W	R/W	R/W	R/W	R/W	R/W	R/W	R/W	R/W	R/W	R/W	R/W	R/W	R/W

Bit	Bit Name	Initial Value	R/W	Description
15	DTCE15	0	R/W	DTC Activation Enable 15 to 0
14	DTCE14	0	R/W	If set to 1, the corresponding interrupt source is specified as a DTC activation source.
13	DTCE13	0	R/W	[Clearing conditions]
12	DTCE12	0	R/W	<ul style="list-style-type: none"> Writing 0 to the bit after reading 1 from it
11	DTCE11	0	R/W	<ul style="list-style-type: none"> When the DISEL bit is 1 and the data transfer has ended
10	DTCE10	0	R/W	<ul style="list-style-type: none"> When the specified number of transfers have ended
9	DTCE9	0	R/W	These bits are not cleared when the DISEL bit is 0 and the specified number of transfers have not ended
8	DTCE8	0	R/W	[Setting condition]
7	DTCE7	0	R/W	<ul style="list-style-type: none"> Writing 1 to the bit after reading 0 from it
6	DTCE6	0	R/W	
5	DTCE5	0	R/W	
4	DTCE4	0	R/W	
3	DTCE3	0	R/W	
2	DTCE2	0	R/W	
1	DTCE1	0	R/W	
0	DTCE0	0	R/W	

8.2.8 DTC Control Register (DTCCR)

DTCCR specifies transfer information read skip.

Bit:	7	6	5	4	3	2	1	0
	-	-	-	RRS	RCHNE	-	-	ERR
Initial value:	0	0	0	0	0	0	0	0
R/W:	R	R	R	R/W	R/W	R	R	R/(W)*

Note: * Writing 0 to this bit after reading it as 1 clears the flag and is the only allowed way.

Bit	Bit Name	Initial Value	R/W	Description
7 to 5	—	All 0	R	Reserved These bits are always read as 0. The write value should always be 0.
4	RRS	0	R/W	DTC Transfer Information Read Skip Enable Controls the vector address read and transfer information read. A DTC vector number is always compared with the vector number for the previous activation. If the vector numbers match and this bit is set to 1, the DTC data transfer is started without reading a vector address and transfer information. If the previous DTC activation is a chain transfer, the vector address read and transfer information read are always performed. However, when the DTPR bit in the bus function extending register (BSCEHR) is set to 1, transfer information read skip is not performed regardless of the setting of this bit. 0: Transfer read skip is not performed. 1: Transfer read skip is performed when the vector numbers match.
3	RCHNE	0	R/W	Chain Transfer Enable After DTC Repeat Transfer Enables/disables the chain transfer while transfer counter (CRAL) is 0 in repeat transfer mode. In repeat transfer mode, the CRAH value is written to CRAL when CRAL is 0. Accordingly, chain transfer may not occur when CRAL is 0. If this bit is set to 1, the chain transfer is enabled when CRAH is written to CRAL. 0: Disables the chain transfer after repeat transfer 1: Enables the chain transfer after repeat transfer

Bit	Bit Name	Initial Value	R/W	Description
2, 1	—	All 0	R	Reserved These are read-only bits and cannot be modified.
0	ERR	0	R/(W)*	Transfer Stop Flag Indicates that the DTC address error or NMI interrupt request has occurred. If a DTC address error or NMI interrupt occurs while the DTC is active, address error handling or NMI interrupt handling processing is executed after the DTC has released the bus mastership. The DTC stops in the transfer information writing state after transferring data. 0: No interrupt occurs 1: An interrupt occurs [Clearing condition] <ul style="list-style-type: none"> • When writing 0 after reading 1

Note: * Writing 0 to this bit after reading it as 1 clears the flag and is the only allowed way.

8.2.9 DTC Vector Base Register (DTCVBR)

DTCVBR is a 32-bit register that specifies the base address for vector table address calculation.

Bit:	31	30	29	28	27	26	25	24	23	22	21	20	19	18	17	16
Initial value:	0	0	0	0	0	0	0	0	0	0	0	0	0	0	0	0
R/W:	R/W	R/W	R/W	R/W	R/W	R/W	R/W	R/W	R/W	R/W	R/W	R/W	R/W	R/W	R/W	R/W
Bit:	15	14	13	12	11	10	9	8	7	6	5	4	3	2	1	0
					-	-	-	-	-	-	-	-	-	-	-	-
Initial value:	0	0	0	0	0	0	0	0	0	0	0	0	0	0	0	0
R/W:	R/W	R/W	R/W	R/W	R	R	R	R	R	R	R	R	R	R	R	R

Bit	Bit Name	Initial Value	R/W	Description
31 to 12		All 0	R/W	Bits 11 to 0 are always read as 0. The write value should always be 0.
11 to 0	—	All 0	R	

8.2.10 Bus Function Extending Register (BSCEHR)

BSCEHR is a 16-bit register that specifies the timing of bus release by the DTC and other functions. This register can be used to give higher priority to the transfer by the DTC and configure the functions that can reduce the number of cycles over which the DTC is active. For more details, see section 9.4.4, Bus Function Extending Register (BSCEHR).

8.3 Activation Sources

The DTC is activated by an interrupt request. The interrupt source is selected by DTCEIR. A DTC activation source can be selected by setting the corresponding bit in DTCEIR; the CPU interrupt source can be selected by clearing the corresponding bit in DTCEIR. At the end of a data transfer (or the last consecutive transfer in the case of chain transfer), the activation source interrupt flag or corresponding DTCEIR bit is cleared.

8.4 Location of Transfer Information and DTC Vector Table

Locate the transfer information in the data area. The start address of transfer information should be located at the address that is a multiple of four (4n). Otherwise, the lower two bits are ignored during access ([1:0] = B'00.) Transfer information located in the data area is shown in figure 8.2.

Only in the case where all transfer sources/transfer destinations are in on-chip RAM and on-chip peripheral modules, short address mode can be selected by setting the DTSA bit in the bus function extending register (BSCEHR) to 1 (see section 9.4.4, Bus Function Extending Register (BSCEHR)).

Normally, four longwords of transfer information has to be read. But if short address mode is selected, the size of transfer information is reduced to three longwords, which can shorten the period over which the DTC is active.

The DTC reads the start address of the transfer information from the vector table for every activation source and reads the transfer information from this start address. Figure 8.3 shows correspondences between the DTC vector table and transfer information.

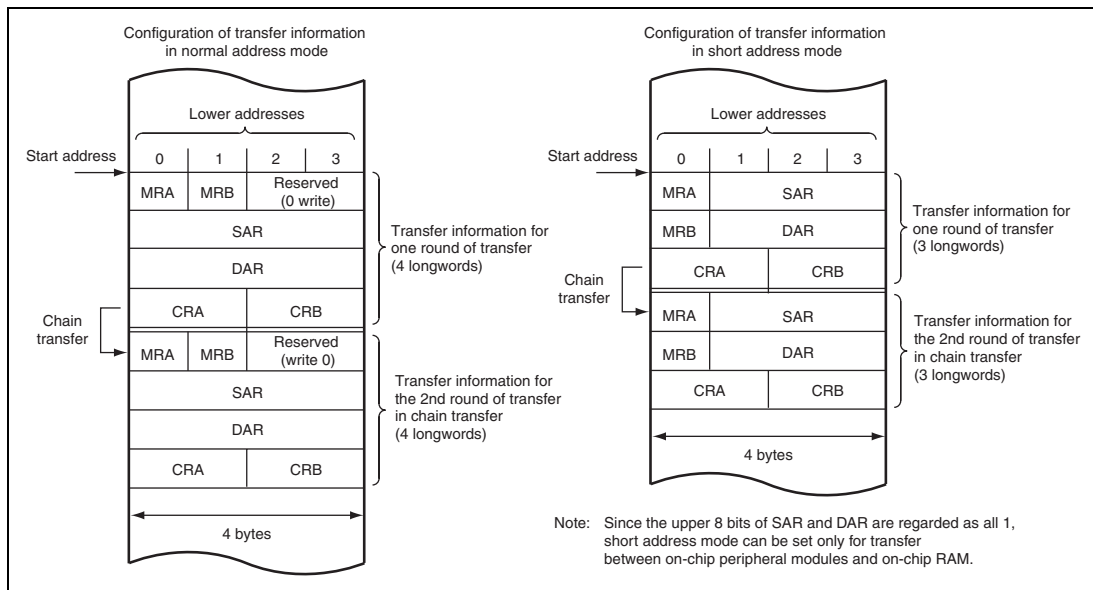

Figure 8.2 Transfer Information on Data Area

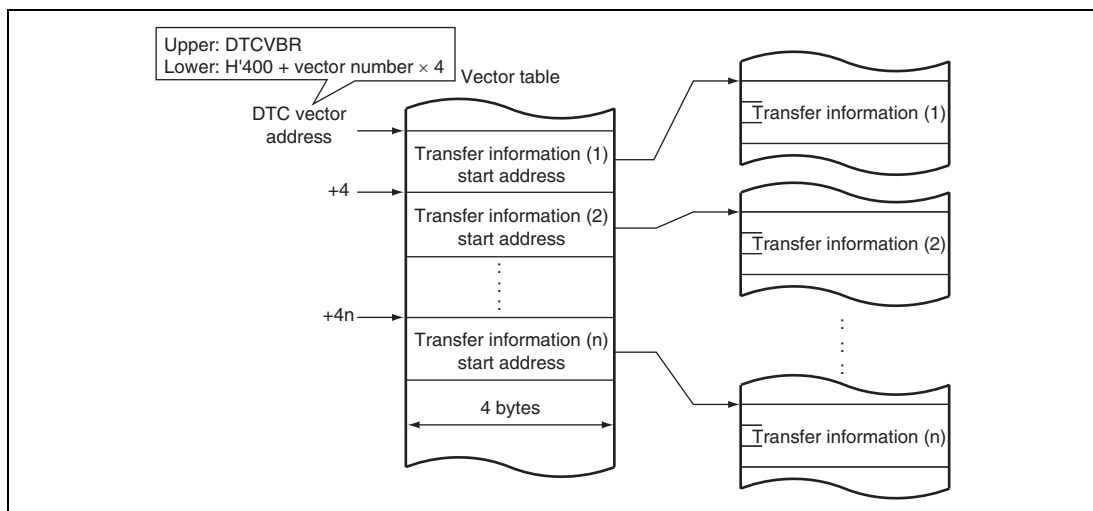

Figure 8.3 Correspondence between DTC Vector Address and Transfer Information

8.5 Operation

There are three transfer modes: normal, repeat, and block transfer modes. Since transfer information is in the data area, it is possible to transfer data over any required number of channels. When activated, the DTC reads transfer information stored in the data area and transfers data according to the transfer information. After the data transfer is complete, it writes updated transfer information back to the data area.

The DTC specifies the source address and destination address in SAR and DAR, respectively. After a transfer, SAR and DAR are incremented, decremented, or fixed independently.

Table 8.3 shows the DTC transfer modes.

Table 8.3 DTC Transfer Modes

Transfer Mode	Size of Data Transferred at One Transfer Request	Memory Address Increment or Decrement	Transfer Count
Normal	1 byte/word/longword	Incremented/decremented by 1, 2, or 4, or fixed	1 to 65536
Repeat* ¹	1 byte/word/longword	Incremented/decremented by 1, 2, or 4, or fixed	1 to 256* ³
Block* ²	Block size specified by CRAH (1 to 256 bytes/words/longwords)	Incremented/decremented by 1, 2, or 4, or fixed	1 to 65536* ⁴

Notes: 1. Either source or destination is specified to repeat area.
 2. Either source or destination is specified to block area.
 3. After transfer of the specified transfer count, initial state is recovered to continue the operation.
 4. Number of transfers of the specified block size of data.

Setting the CHNE bit in MRB to 1 makes it possible to perform a number of transfers with a single activation (chain transfer). Setting the CHNS bit in MRB to 1 can also be made to have chain transfer performed only when the transfer counter value is 0.

Figure 8.4 shows a flowchart of DTC operation, and table 8.4 summarizes the conditions for DTC transfers including chain transfer (combinations for performing the second and third transfers are omitted).

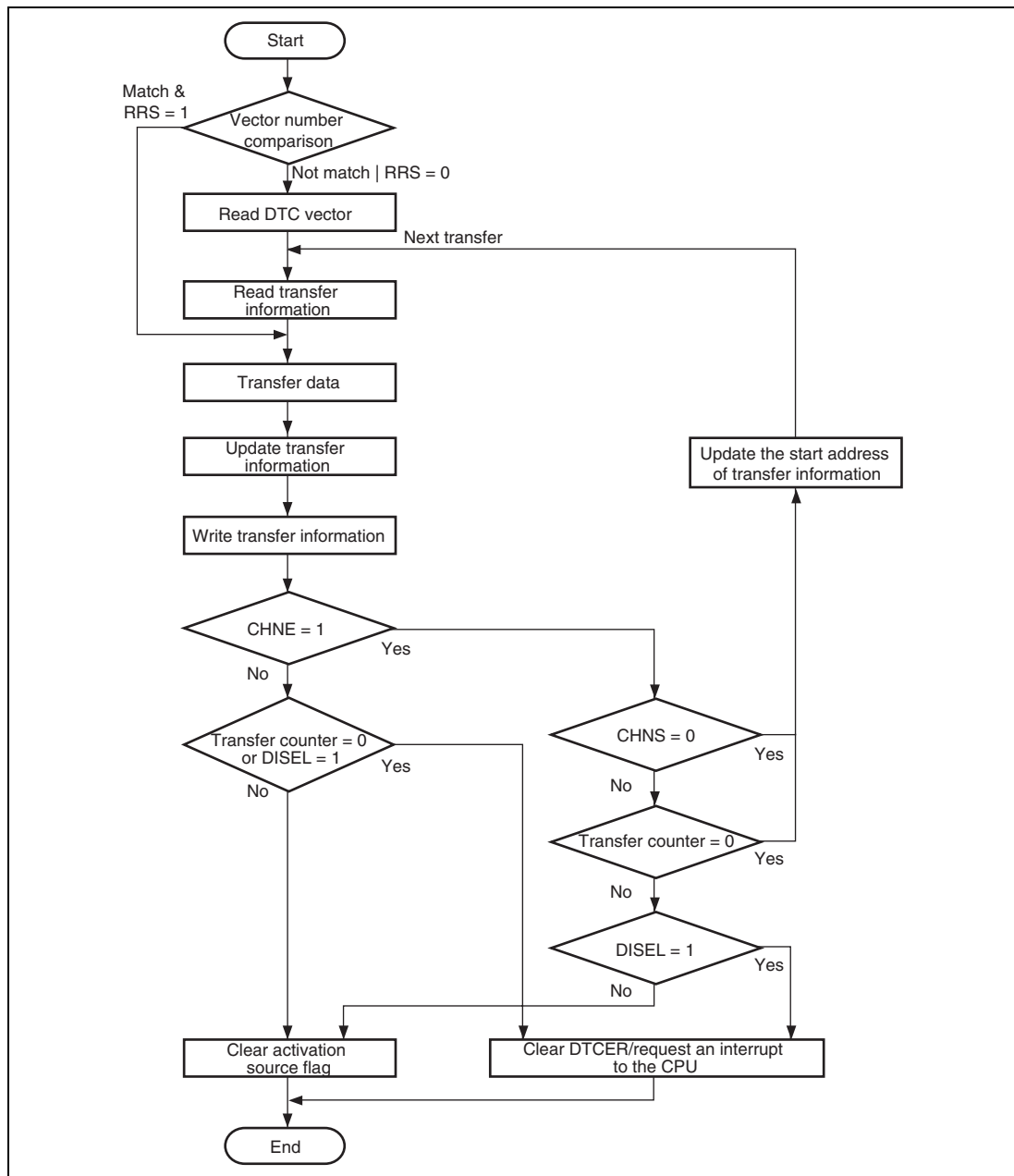

Figure 8.4 Flowchart of DTC Operation

Table 8.4 DTC Transfer Conditions (Chain Transfer Conditions Included)

Transfer Mode	1st Transfer					2nd Transfer					DTC Transfer
	CHNE	CHNS	RCHNE	DISEL	Transfer Counter* ¹	CHNE	CHNS	RCHNE	DISEL	Transfer Counter* ¹	
Normal	0	—	—	0	Not 0	—	—	—	—	—	Ends at 1st transfer
	0	—	—	0	0	—	—	—	—	—	Ends at 1st transfer
	0	—	—	1	—	—	—	—	—	—	Interrupt request to CPU
	1	0	—	—	—	0	—	—	0	Not 0	Ends at 2nd transfer
						0	—	—	0	0	Ends at 2nd transfer
						0	—	—	1	—	Interrupt request to CPU
	1	1	—	0	Not 0	—	—	—	—	—	Ends at 1st transfer
	1	1	—	1	Not 0	—	—	—	—	—	Ends at 1st transfer Interrupt request to CPU
	1	1	—	—	0	0	—	—	0	Not 0	Ends at 2nd transfer
						0	—	—	0	0	Ends at 2nd transfer
						0	—	—	1	—	Interrupt request to CPU

Transfer Mode	1st Transfer					2nd Transfer					DTC Transfer
	CHNE	CHNS	RCHNE	DISEL	Transfer Counter* ¹	CHNE	CHNS	RCHNE	DISEL	Transfer Counter* ¹	
Repeat	0	—	—	0	—	—	—	—	—	—	Ends at 1st transfer
	0	—	—	1	—	—	—	—	—	—	Ends at 1st transfer Interrupt request to CPU
	1	0	—	—	—	0	—	—	0	—	Ends at 2nd transfer
						0	—	—	1	—	Ends at 2nd transfer Interrupt request to CPU
	1	1	—	0	Not 0	—	—	—	—	—	Ends at 1st transfer
	1	1	—	1	Not 0	—	—	—	—	—	Ends at 1st transfer Interrupt request to CPU
	1	1	0	0	0* ²	—	—	—	—	—	Ends at 1st transfer
	1	1	0	1	0* ²	—	—	—	—	—	Ends at 1st transfer Interrupt request to CPU
	1	1	1	—	0* ²	0	—	—	0	—	Ends at 2nd transfer
						0	—	—	1	—	Ends at 2nd transfer Interrupt request to CPU

Transfer Mode	1st Transfer					2nd Transfer					DTC Transfer
	CHNE	CHNS	RCHNE	DISEL	Transfer Counter* ¹	CHNE	CHNS	RCHNE	DISEL	Transfer Counter* ¹	
Block	0	—	—	0	Not 0	—	—	—	—	—	Ends at 1st transfer
	0	—	—	0	0	—	—	—	—	—	Ends at 1st transfer
	0	—	—	1	—	—	—	—	—	—	Interrupt request to CPU
	1	0	—	—	—	0	—	—	0	Not 0	Ends at 2nd transfer
						0	—	—	0	0	Ends at 2nd transfer
						0	—	—	1	—	Interrupt request to CPU
	1	1	—	0	—	—	—	—	—	—	Ends at 1st transfer
	1	1	—	1	Not 0	—	—	—	—	—	Ends at 1st transfer Interrupt request to CPU
	1	1	—	1	0	0	—	—	0	Not 0	Ends at 2nd transfer
						0	—	—	0	0	Ends at 2nd transfer
						0	—	—	1	—	Interrupt request to CPU

Notes: 1. CRA in normal mode transfer, CRAL in repeat transfer mode, or CRB in block transfer mode

2. When the contents of the CRAH is written to the CRAL in repeat transfer mode

8.5.1 Transfer Information Read Skip Function

By setting the RRS bit of DTCCR, the vector address read and transfer information read can be skipped. The current DTC vector number is always compared with the vector number of previous activation. If the vector numbers match when RRS = 1, a DTC data transfer is performed without reading the vector address and transfer information. If the previous activation is a chain transfer, the vector address read and transfer information read are always performed. Figure 8.5 shows the transfer information read skip timing.

To modify the vector table and transfer information, temporarily clear the RRS bit to 0, modify the vector table and transfer information, and then set the RRS bit to 1 again. When the RRS bit is cleared to 0, the stored vector number is deleted, and the updated vector table and transfer information are read at the next activation.

If the DTPR bit in the bus function extending register (BSCEHR) is set to 1, this function is always disabled.

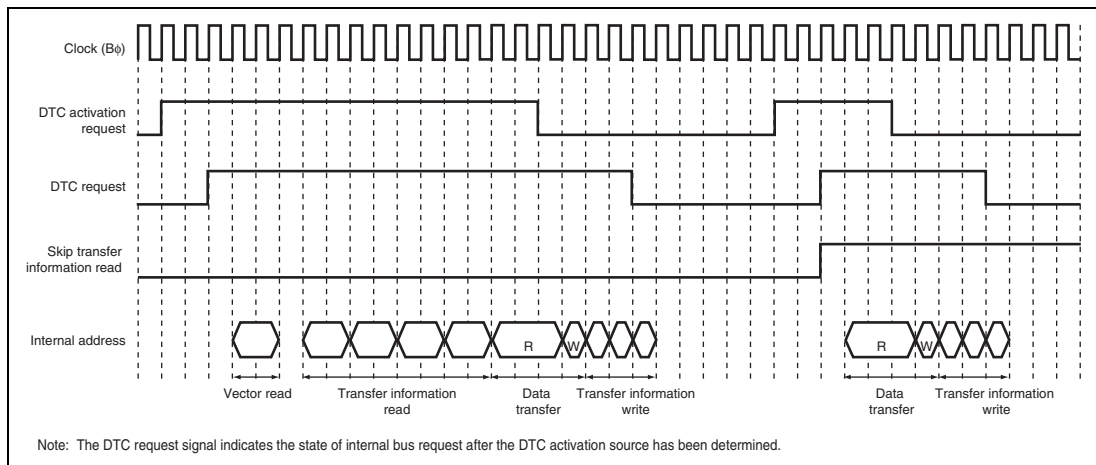

Figure 8.5 Transfer Information Read Skip Timing
 (Activated by On-Chip Peripheral Module; I ϕ : B ϕ : P ϕ = 1: 1/2: 1/2;
 Data Transferred from On-Chip Peripheral Module to On-Chip RAM;
 Transfer Information Is Written in 3 States)

8.5.2 Transfer Information Writeback Skip Function

By specifying bit SM1 in MRA and bit DM1 in MRB to the fixed address mode, a part of transfer information will not be written back. Table 8.5 shows the transfer information writeback skip condition and writeback skipped registers. Note that the CRA and CRB are always written back. The writeback of the MRA and MRB are always skipped.

Table 8.5 Transfer Information Writeback Skip Condition and Writeback Skipped Registers

SM1	DM1	SAR	DAR
0	0	Skipped	Skipped
0	1	Skipped	Written back
1	0	Written back	Skipped
1	1	Written back	Written back

8.5.3 Normal Transfer Mode

In normal transfer mode, data are transferred in one byte, one word, or one longword units in response to a single activation request. From 1 to 65,536 transfers can be specified. The transfer source and destination addresses can be specified as incremented, decremented, or fixed. When the specified number of transfers ends, an interrupt can be requested to the CPU.

Table 8.6 lists the register function in normal transfer mode. Figure 8.6 shows the memory map in normal transfer mode.

Table 8.6 Register Function in Normal Transfer Mode

Register	Function	Written Back Value
SAR	Source address	Incremented/decremented/fixed*
DAR	Destination address	Incremented/decremented/fixed*
CRA	Transfer count A	CRA – 1
CRB	Transfer count B	Not updated

Note: * Transfer information writeback is skipped.

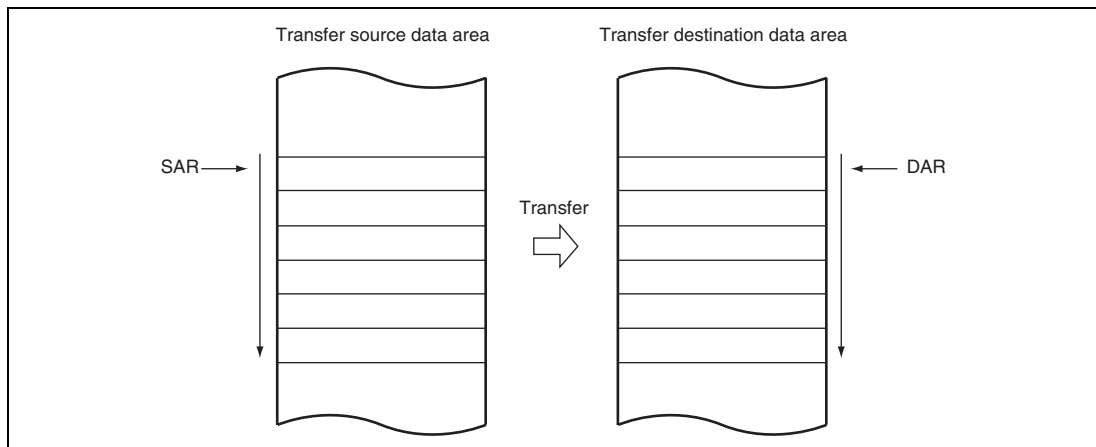

Figure 8.6 Memory Map in Normal Transfer Mode

8.5.4 Repeat Transfer Mode

In repeat transfer mode, data are transferred in one byte, one word, or one longword units in response to a single activation request. By the DTS bit in MRB, either the source or destination can be specified as a repeat area. From 1 to 256 transfers can be specified. When the specified number of transfers ends, the transfer counter and address register specified as the repeat area is restored to the initial state, and transfer is repeated. The other address register is then incremented, decremented, or left fixed. In repeat transfer mode, the transfer counter (CRAL) is updated to the value specified in CRAH when CRAL becomes H'00. Thus the transfer counter value does not reach H'00, and therefore a CPU interrupt cannot be requested when DISEL = 0.

Table 8.7 lists the register function in repeat transfer mode. Figure 8.7 shows the memory map in repeat transfer mode.

Table 8.7 Register Function in Repeat Transfer Mode

Register	Function	Written Back Value	
		CRAL is not 1	CRAL is 1
SAR	Source address	Incremented/decremented/fixed*	DTS = 0: Incremented/ decremented/fixed* DTS = 1: SAR initial value
DAR	Destination address	Incremented/decremented/fixed*	DTS = 0: DAR initial value DTS = 1: Incremented/ decremented/fixed*
CRAH	Transfer count storage	CRAH	CRAH
CRAL	Transfer count A	CRAL – 1	CRAH
CRB	Transfer count B	Not updated	Not updated

Note: * Transfer information writeback is skipped.

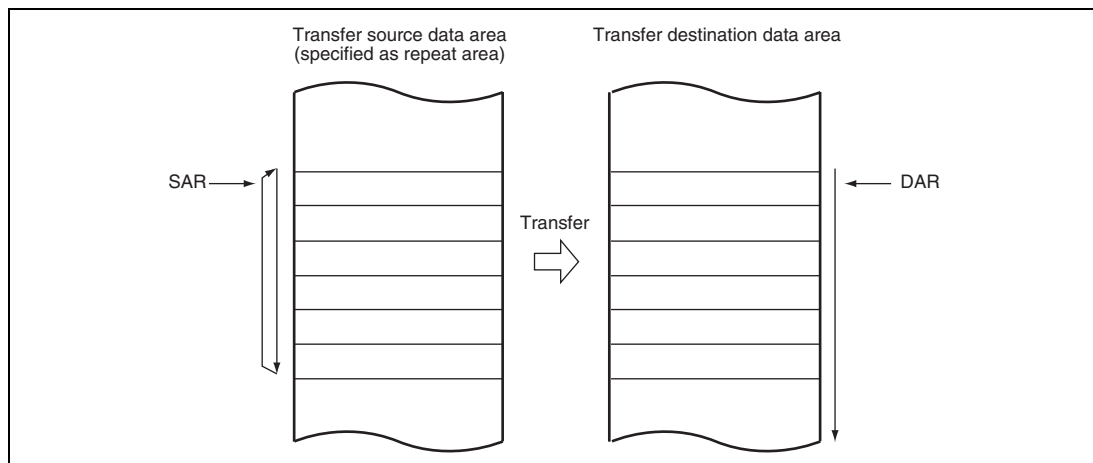

**Figure 8.7 Memory Map in Repeat Transfer Mode
(When Transfer Source Is Specified as Repeat Area)**

8.5.5 Block Transfer Mode

In block transfer mode, data are transferred in block units in response to a single activation request. Either the transfer source or the transfer destination is designated as a block area by the DTS bit in MRB.

The block size is 1 to 256 bytes (1 to 256 words, or 1 to 256 longwords). When the block data transfer of one block ends, the block size counter (CRAL) and address register (SAR when DTS = 1 or DAR when DTS = 0) specified as the block area is restored to the initial state. The other address register is then incremented, decremented, or left fixed. From 1 to 65,536 transfers can be specified. When the specified number of transfers ends, an interrupt is requested to the CPU.

Table 8.8 lists the register function in block transfer mode. Figure 8.8 shows the memory map in block transfer mode.

Table 8.8 Register Function in Block Transfer Mode

Register	Function	Written Back Value
SAR	Source address	DTS = 0: Incremented/decremented/fixed* DTS = 1: SAR initial value
DAR	Destination address	DTS = 0: DAR initial value DTS = 1: Incremented/decremented/fixed*
CRAH	Block size storage	CRAH
CRAL	Block size counter	CRAH
CRB	Block transfer counter	CRB – 1

Note: * Transfer information writeback is skipped.

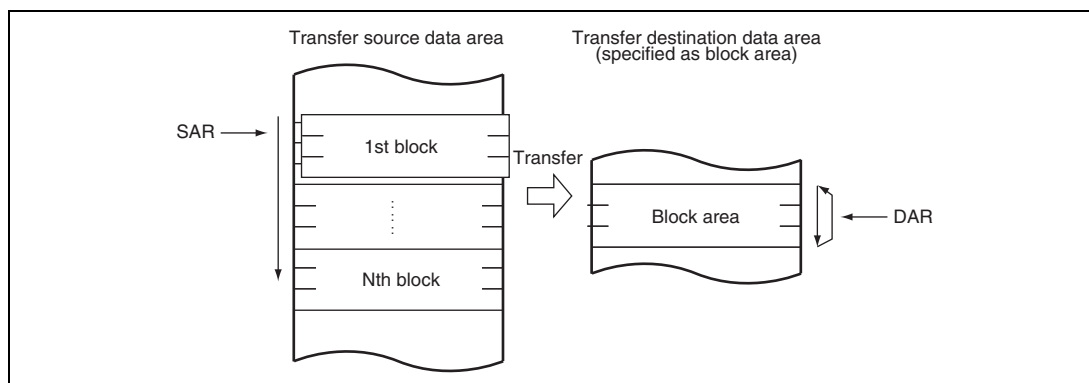

**Figure 8.8 Memory Map in Block Transfer Mode
(When Transfer Destination Is Specified as Block Area)**

8.5.6 Chain Transfer

Setting the CHNE bit in MRB to 1 enables a number of data transfers to be performed consecutively in response to a single transfer request. Setting the CHNE and CHNS bits in MRB set to 1 enables a chain transfer only when the transfer counter reaches 0. SAR, DAR, CRA, CRB, MRA, and MRB, which define data transfers, can be set independently. Figure 8.9 shows the chain transfer operation.

In the case of transfer with CHNE set to 1, an interrupt request to the CPU is not generated at the end of the specified number of transfers or by setting the DISEL bit to 1, and the interrupt source flag for the activation source and DTCER are not affected.

In repeat transfer mode, setting the RCHNE bit in DTCCR and the CHNE and CHNS bits in MRB to 1 enables a chain transfer after transfer with transfer counter = 1 has been completed.

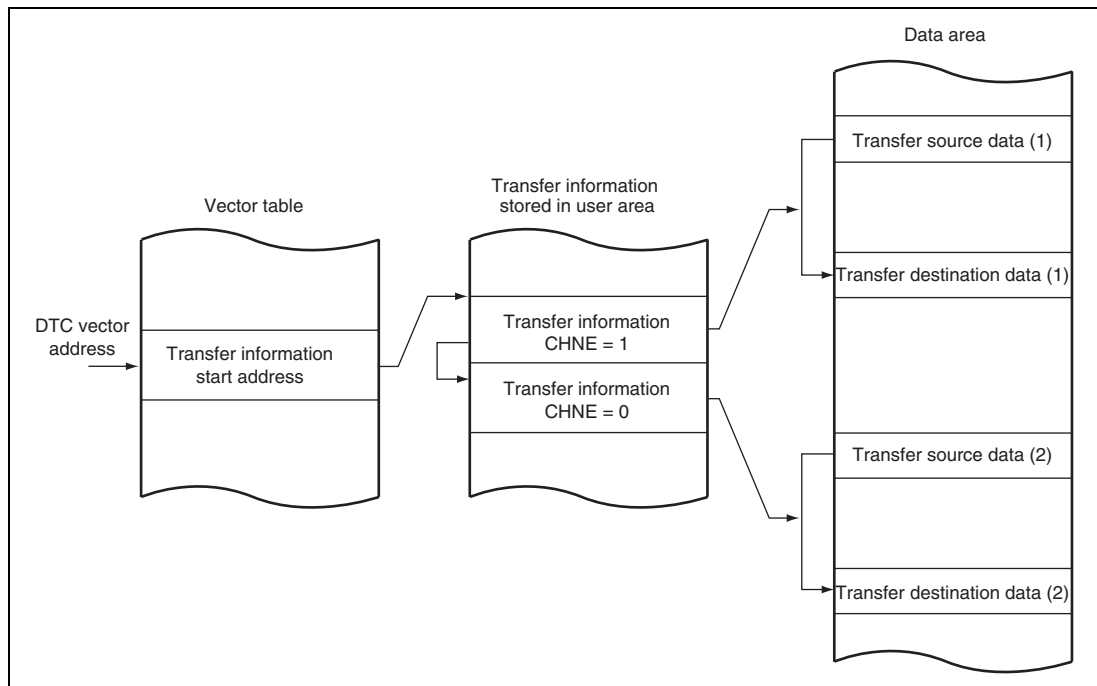
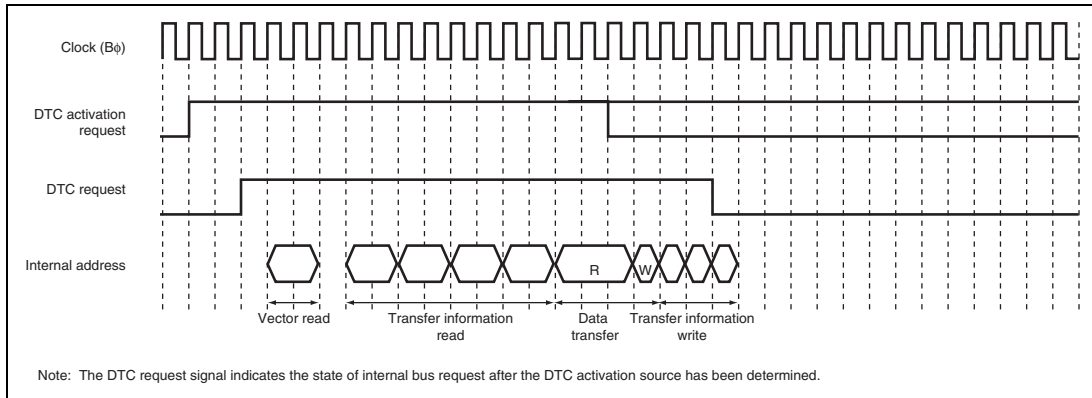

Figure 8.9 Operation of Chain Transfer

8.5.7 Operation Timing

Figures 8.10 to 8.15 show the DTC operation timings.



**Figure 8.10 Example of DTC Operation Timing:
Normal Transfer Mode or Repeat Transfer Mode
(Activated by On-Chip Peripheral Module; Iφ: Bφ: Pφ =1: 1/2: 1/2;
Data Transferred from On-Chip Peripheral Module to On-Chip RAM;
Transfer Information Is Written in 3 Cycles)**

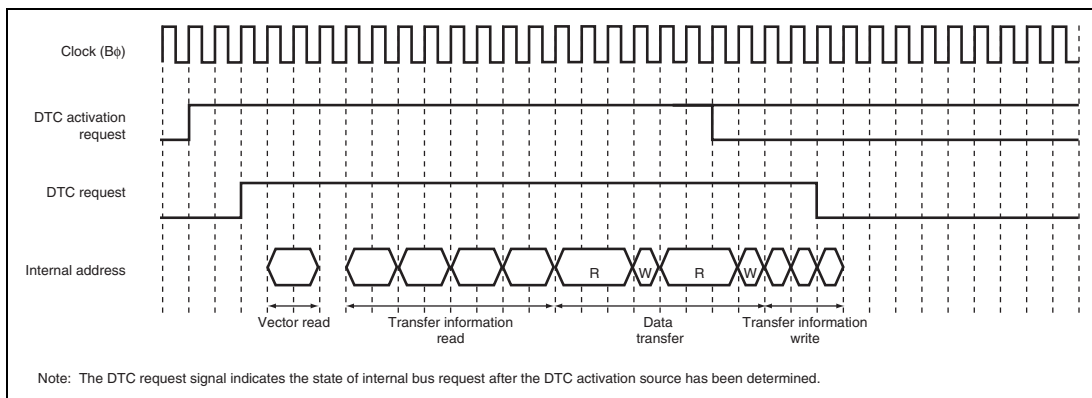

**Figure 8.11 Example of DTC Operation Timing:
Block Transfer Mode with Block Size = 2
(Activated by On-Chip Peripheral Module; Iφ: Bφ: Pφ =1: 1/2: 1/2;
Data Transferred from On-Chip Peripheral Module to On-Chip RAM;
Transfer Information Is Written in 3 Cycles)**

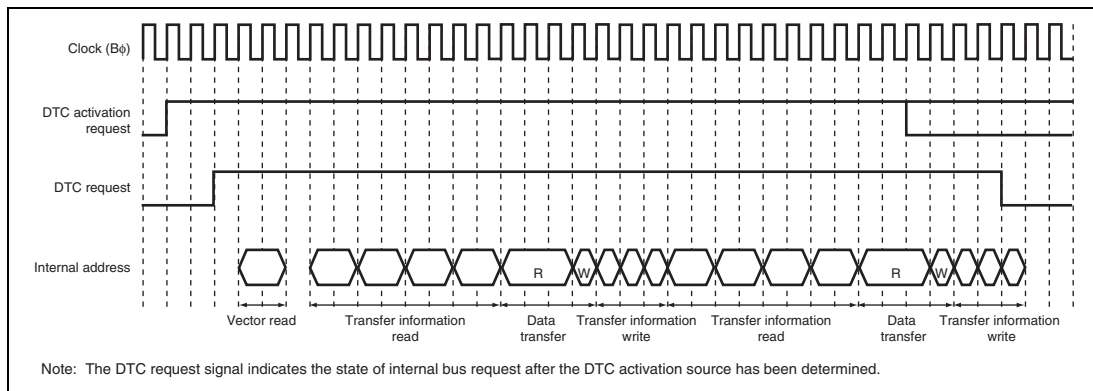

Figure 8.12 Example of DTC Operation Timing: Chain Transfer
(Activated by On-Chip Peripheral Module; Iφ: Bφ: Pφ =1: 1/2: 1/2;
Data Transferred from On-Chip Peripheral Module to On-Chip RAM;
Transfer Information Is Written in 3 Cycles)

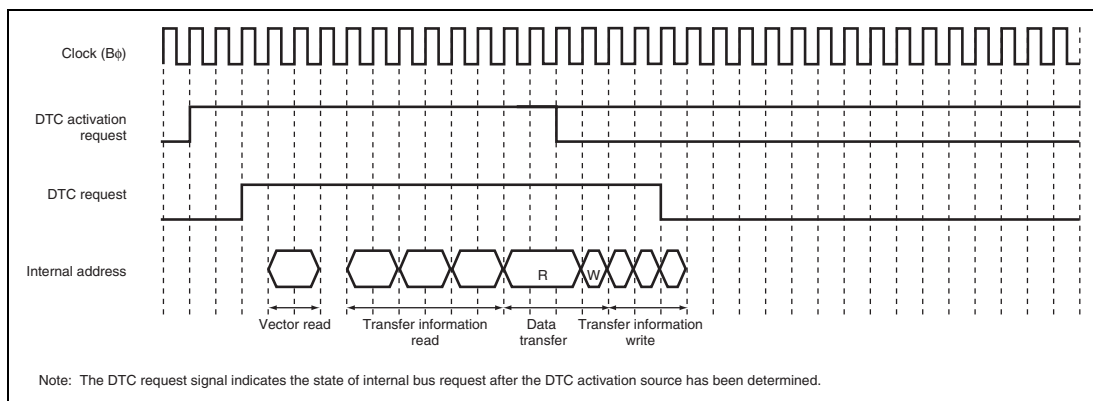
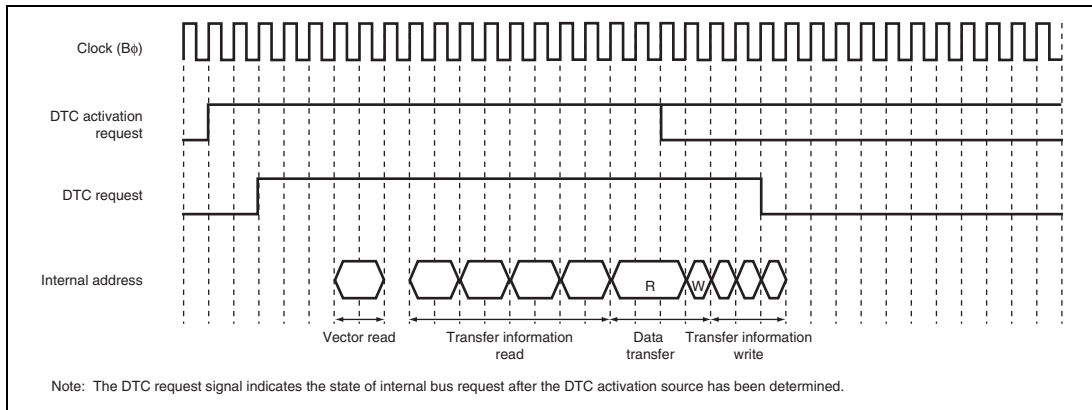
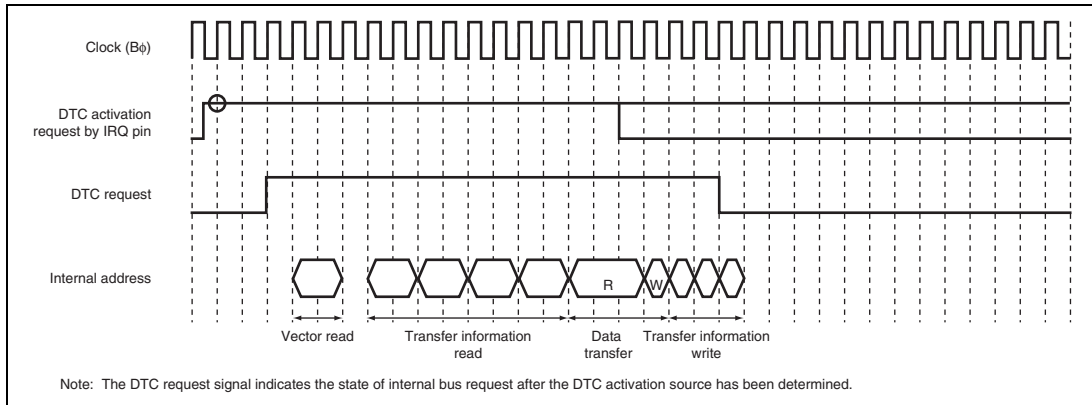

Figure 8.13 Example of DTC Operation Timing:
Normal or Repeat Transfer in Short Address Mode
(Activated by On-Chip Peripheral Module; Iφ: Bφ: Pφ =1: 1/2: 1/2;
Data Transferred from On-Chip Peripheral Module to On-Chip RAM;
Transfer Information Is Written in 3 Cycles)



**Figure 8.14 Example of DTC Operation Timing:
Normal or Repeat Transfer with DTPR = 1
(Activated by On-Chip Peripheral Module; Iφ: Bφ: Pφ =1: 1/2: 1/2;
Data Transferred from On-Chip Peripheral Module to On-Chip RAM;
Transfer Information Is Written in 3 Cycles)**



**Figure 8.15 Example of DTC Operation Timing:
Normal or Repeat Transfer
(Activated by IRQ; Iφ: Bφ: Pφ =1: 1/2: 1/2;
Data Transferred from On-Chip Peripheral Module to On-Chip RAM;
Transfer Information Is Written in 3 Cycles)**

8.5.8 Number of DTC Execution Cycles

Table 8.9 shows the execution status for a single DTC data transfer, and table 8.10 shows the number of cycles required for each execution.

Table 8.9 DTC Execution Status

Mode	Vector Read		Transfer Information Read			Transfer Information Write			Data Read	Data Write	Internal Operation	
	I	0* ¹	J	3* ⁴	0* ¹	K	2* ²	1* ³	L	M	N	0* ¹
Normal	1	0* ¹	4	3* ⁴	0* ¹	3	2* ²	1* ³	1	1	1	0* ¹
Repeat	1	0* ¹	4	3* ⁴	0* ¹	3	2* ²	1* ³	1	1	1	0* ¹
Block transfer	1	0* ¹	4	3* ⁴	0* ¹	3	2* ²	1* ³	1•P	1•P	1	0* ¹

[Legend]

P: Block size (initial setting of CRAH and CRAL)

- Notes:
1. When transfer information read is skipped
 2. When the SAR or DAR is in fixed mode
 3. When the SAR and DAR are in fixed mode
 4. When short address mode

Table 8.10 Number of Cycles Required for Each Execution State

Object to be Accessed		On-Chip	On-Chip I/O Registers	External Devices* ⁴	
		RAM* ¹ /ROM* ²		8 bits	16 bits
Bus width		32 bits	16 bits	8 bits	16 bits
Access cycles		1B ϕ to 3B ϕ * ^{1,2}	2P ϕ	2B ϕ	2B ϕ
Execution status	Vector read S _i	1B ϕ to 3B ϕ * ^{1,2}	—	9B ϕ	5B ϕ
	Transfer information read S _j	1B ϕ to 3B ϕ * ¹	—	9B ϕ	5B ϕ
	Transfer information write S _k	1B ϕ to 3B ϕ * ¹	—	2B ϕ * ⁵	2B ϕ * ⁵
	Byte data read S _L	1B ϕ to 3B ϕ * ¹	1B ϕ + 2P ϕ * ³	3B ϕ	3B ϕ
	Word data read S _L	1B ϕ to 3B ϕ * ¹	1B ϕ + 2P ϕ * ³	5B ϕ	3B ϕ
	Longword data read S _L	1B ϕ to 3B ϕ * ¹	1B ϕ + 4P ϕ * ³	9B ϕ	5B ϕ
	Byte data write S _M	1B ϕ to 3B ϕ * ¹	1B ϕ + 2P ϕ * ³	2B ϕ * ⁵	2B ϕ * ⁵
	Word data write S _M	1B ϕ to 3B ϕ * ¹	1B ϕ + 2P ϕ * ³	2B ϕ * ⁵	2B ϕ * ⁵
	Longword data write S _M	1B ϕ to 3B ϕ * ¹	1B ϕ + 4P ϕ * ³	2B ϕ * ⁵	2B ϕ * ⁵
	Internal operation S _N			1	

Notes: 1. Values for on-chip RAM. Number of cycles varies depending on the ratio of I ϕ :B ϕ .

	Read	Write
I ϕ :B ϕ = 1:1	3B ϕ	3B ϕ
I ϕ :B ϕ = 1:1/2	2B ϕ	1B ϕ
I ϕ :B ϕ = 1:1/3	2B ϕ	1B ϕ
I ϕ :B ϕ = 1:1/4 or less	1B ϕ	1B ϕ

- Values for on-chip ROM. Number of cycles varies depending on the ratio of I ϕ :B ϕ and are the same as on-chip RAM. Only vector read is possible.
- The values in the table are those for the fastest case. Depending on the state of the internal bus, replace 1B ϕ by 1P ϕ in a slow case.
- Values are different depending on the BSC register setting. The values in the table are the sample for the case with no wait cycles and the WM bit in CSnWCR = 1.
- Values are different depending on the bus state.

The number of cycles increases when many external wait cycles are inserted in the case where writing is frequently executed, such as block transfer, and when the external bus is in use because the write buffer cannot be used efficiently in such cases. For details on the write buffer, see section 9.5.7 (2), Access in View of LSI Internal Bus Master.

The number of execution cycles is calculated from the formula below. Note that Σ means the sum of cycles for all transfers initiated by one activation event (the number of 1-valued CHNE bits in transfer information plus 1).

$$\text{Number of execution cycles} = I \cdot S_I + \Sigma (J \cdot S_J + K \cdot S_K + L \cdot S_L + M \cdot S_M) + N \cdot S_N$$

8.5.9 DTC Bus Release Timing

The DTC requests the bus mastership to the bus arbiter when an activation request occurs. The DTC releases the bus mastership after a vector read, NOP cycle generation after a vector read, transfer information read, a single data transfer, or transfer information writeback. The DTC does not release the bus mastership during transfer information read, single data transfer, or transfer information writeback.

The bus mastership release timing can be specified through the bus function extending register (BSCEHR). For details see section 9.4.4, Bus Function Extending Register (BSCEHR). The difference in bus mastership release timing according to the register setting is summarized in table 8.11. Settings other than settings 1 to 5 are not allowed. The setting must not be changed while the DTC is active.

Figure 8.16 is a timing chart showing an example of bus mastership release timing.

Table 8.11 DTC Bus Release Timing

Setting	Bus Function Extending Register (BSCEHR) Setting					Bus Release Timing (O: Bus is released; x: Bus is not released)					
	DTLOCK	CSSTP1	CSSTP2	CSSTP3	DTBST	After vector read	NOP cycle generation* ¹	After	After a	After write-back of	
								transfer	single	Normal	Continuous
								information	data	transfer	transfer
Setting 1	1	0	* ³	1	0	O	O	O	O	O	O
Setting 2	0	0	0	* ³	0	x	O	x	x	O	O
Setting 3	0	1	* ³	* ³	0	x	x	x	x	O	O
Setting 4* ²	0	1	* ³	* ³	1	x	x	x	x	O	x
Setting 5	1	1	* ³	1	0	O	x	O	O	O	O

- Notes:
- The bus mastership is only released for the external space access request from the CPU after a vector read.
 - There are following restrictions in setting 4.
 - Clock setting by the frequency control register (FRQCR) must be $I\phi:B\phi:P\phi:MI\phi:MP\phi = 8:4:4:4:4, 4:2:2:2:2, \text{ or } 2:1:1:1:1$.
 - Locate vector information in on-chip ROM or on-chip RAM.
 - Locate transfer information in on-chip RAM.
 - Transfer is allowed between on-chip RAM and on-chip peripheral module or between external memory and on-chip peripheral module.
 - Don't care.

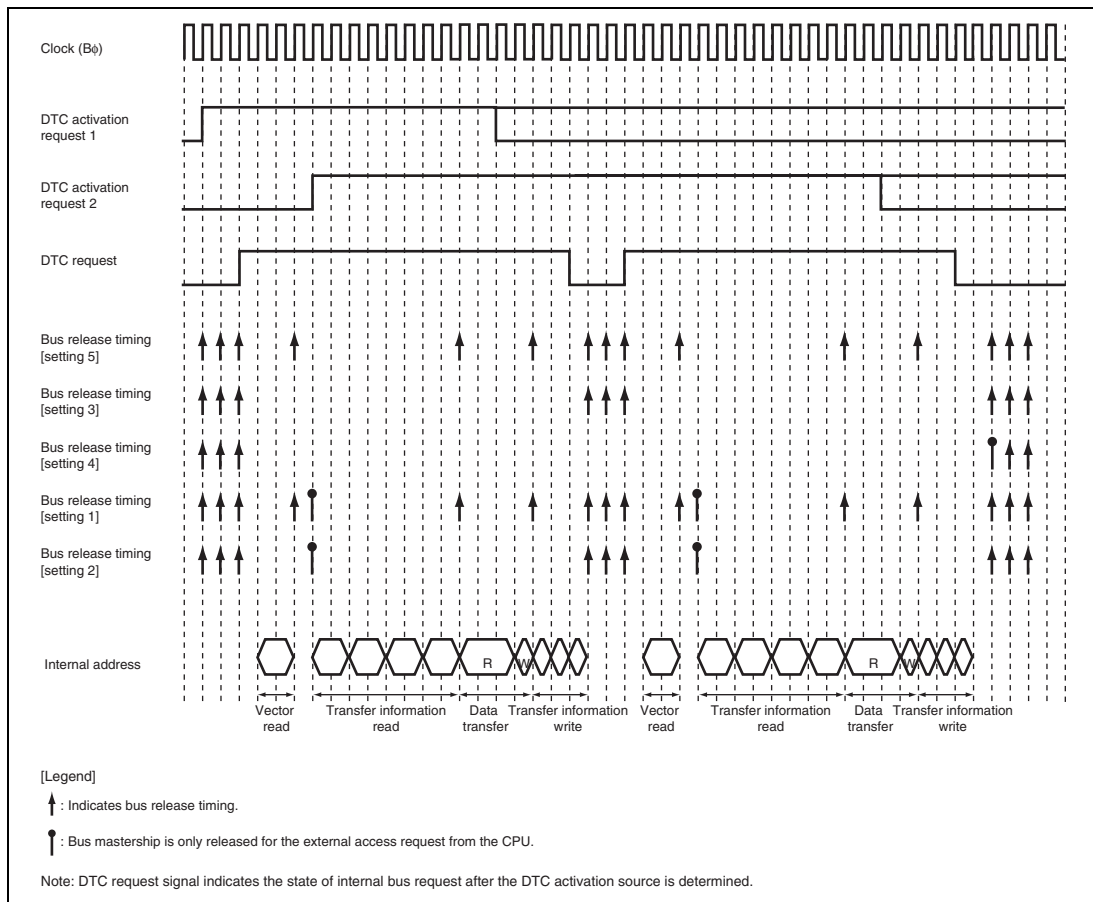

**Figure 8.16 Example of DTC Operation Timing:
 Conflict of Two Activation Requests in Normal Transfer Mode
 (Activated by On-Chip Peripheral Module; Iφ: Bφ: Pφ = 1: 1/2: 1/2;
 Data Transferred from On-Chip Peripheral Module to On-Chip RAM;
 Transfer Information Is Written in 3 Cycles)**

8.5.10 DTC Activation Priority Order

In the case where multiple DTC activation requests are generated while the DTC is inactive, it is selectable whether the DTC starts transfer in the order of activation request generation or in the order of priority for DTC activation. This selection is made by the setting of the DTPR bit in the bus function extending register (BSCEHR). On the other hand, if multiple activation requests are generated while the DTC is active, transfer is performed according to the priority order for DTC activation. Figure 8.17 shows an example of DTC activation according to the priority.

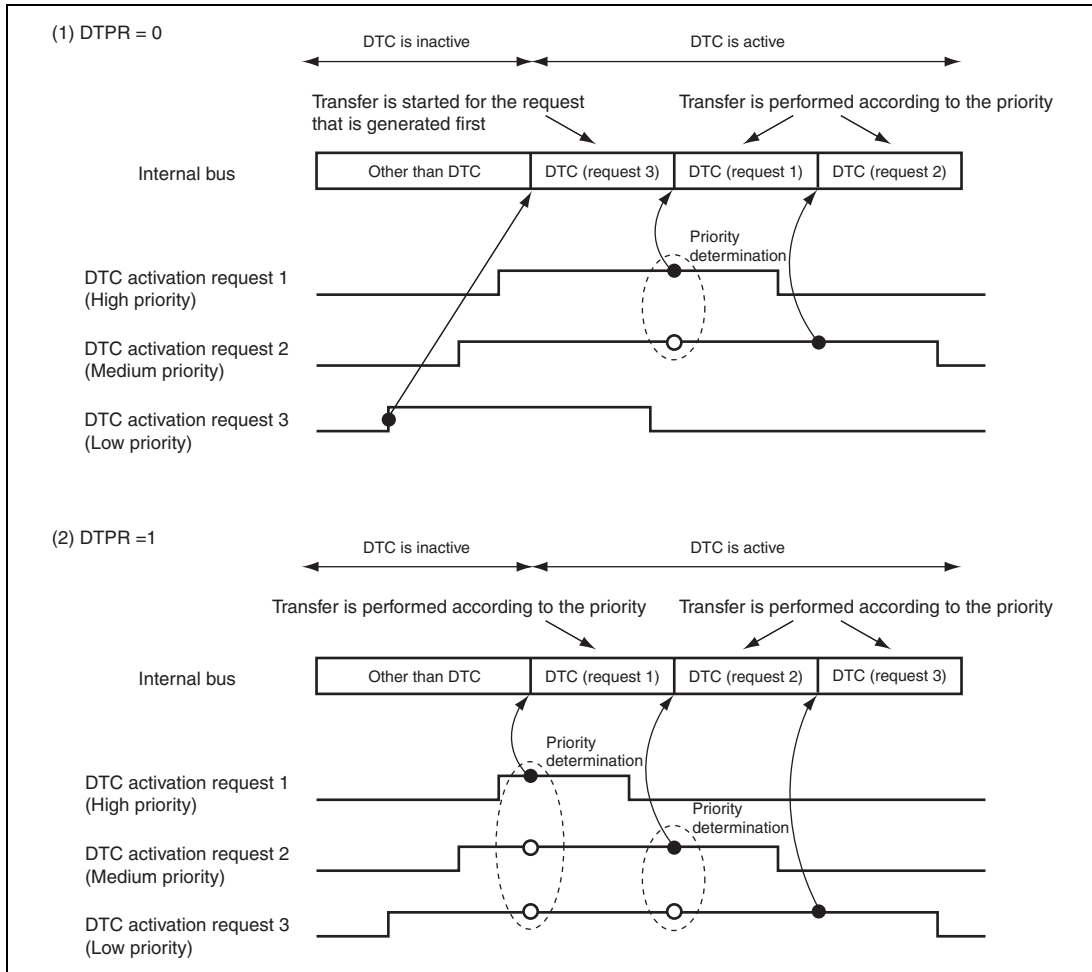

Figure 8.17 Example of DTC Activation in Accordance with Priority

8.6 DTC Activation by Interrupt

The procedure for using the DTC with interrupt activation is shown in figure 8.18.

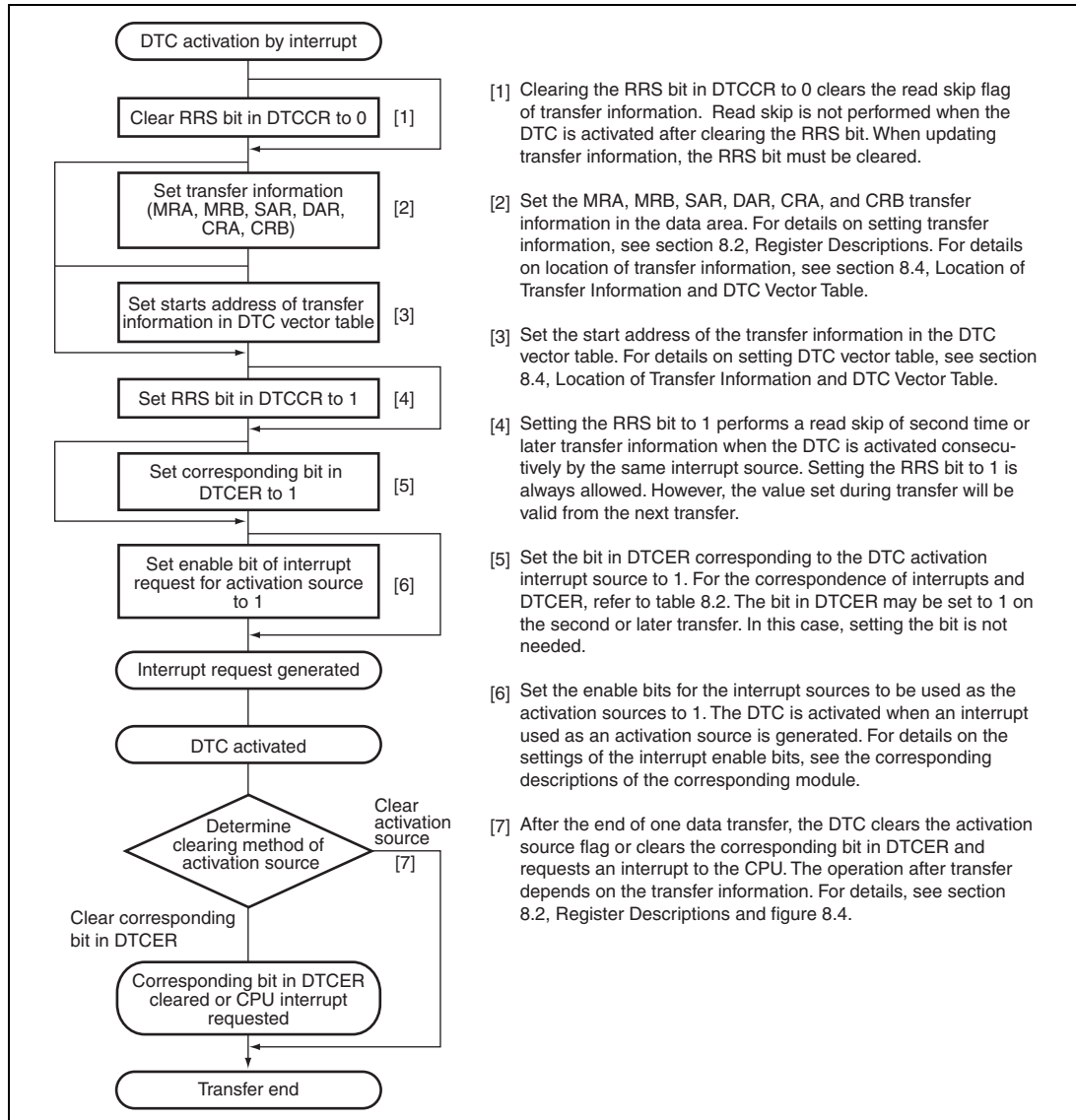

Figure 8.18 Activation of DTC by Interrupt

8.7 Examples of Use of the DTC

8.7.1 Normal Transfer Mode

An example is shown in which the DTC is used to receive 128 bytes of data via the SCI.

1. Set MRA to fixed source address (SM1 = SM0 = 0), incrementing destination address (DM1 = 1, DM0 = 0), normal transfer mode (MD1 = MD0 = 0), and byte size (Sz1 = Sz0 = 0). The DTS bit can have any value. Set MRB for one data transfer by one interrupt (CHNE = 0, DISEL = 0). Set the RDR address of the SCI in SAR, the start address of the RAM area where the data will be received in DAR, and 128 (H'0080) in CRA. CRB can be set to any value.
2. Set the start address of the transfer information for an RXI interrupt at the DTC vector address.
3. Set the corresponding bit in DTCER to 1.
4. Set the SCI to the appropriate receive mode. Set the RIE bit in SCR to 1 to enable the receive end (RXI) interrupt. Since the generation of a receive error during the SCI reception operation will disable subsequent reception, the CPU should be enabled to accept receive error interrupts.
5. Each time reception of one byte of data ends on the SCI, the RDRF flag in SSR is set to 1, an RXI interrupt is generated, and the DTC is activated. The receive data is transferred from RDR to RAM by the DTC. DAR is incremented and CRA is decremented. The RDRF flag is automatically cleared to 0.
6. When CRA becomes 0 after the 128 data transfers have ended, the RDRF flag is held at 1, the DTCE bit is cleared to 0, and an RXI interrupt request is sent to the CPU. Termination processing should be performed in the interrupt handling routine.

8.7.2 Chain Transfer when Counter = 0

By executing a second data transfer and performing re-setting of the first data transfer only when the counter value is 0, it is possible to perform 256 or more repeat transfers.

An example is shown in which a 128-kbyte input buffer is configured. The input buffer is assumed to have been set to start at lower address H'0000. Figure 8.19 shows the chain transfer when the counter value is 0.

1. For the first transfer, set the normal transfer mode for input data. Set the fixed transfer source address, CRA = H'0000 (65,536 times), CHNE = 1, CHNS = 1, and DISEL = 0.
2. Prepare the upper 8-bit addresses of the start addresses for 65,536-transfer units for the first data transfer in a separate area (in ROM, etc.). For example, if the input buffer is configured at addresses H'200000 to H'21FFFF, prepare H'21 and H'20.

3. For the second transfer, set repeat transfer mode (with the source side as the repeat area) for re-setting the transfer destination address for the first data transfer. Use the upper eight bits of DAR in the first transfer information area as the transfer destination. Set CHNE = DISEL = 0. If the above input buffer is specified as H'200000 to H'21FFFF, set the transfer counter to 2.
4. Execute the first data transfer 65536 times by means of interrupts. When the transfer counter for the first data transfer reaches 0, the second data transfer is started. Set the upper eight bits of the transfer destination address for the first data transfer to H'21. The lower 16 bits of the transfer destination address of the first data transfer and the transfer counter are H'0000.
5. Next, execute the first data transfer the 65536 times specified for the first data transfer by means of interrupts. When the transfer counter for the first data transfer reaches 0, the second data transfer is started. Set the upper eight bits of the transfer destination address for the first data transfer to H'20. The lower 16 bits of the transfer destination address of the first data transfer and the transfer counter are H'0000.
6. Steps 4 and 5 are repeated endlessly. As repeat mode is specified for the second data transfer, no interrupt request is sent to the CPU.

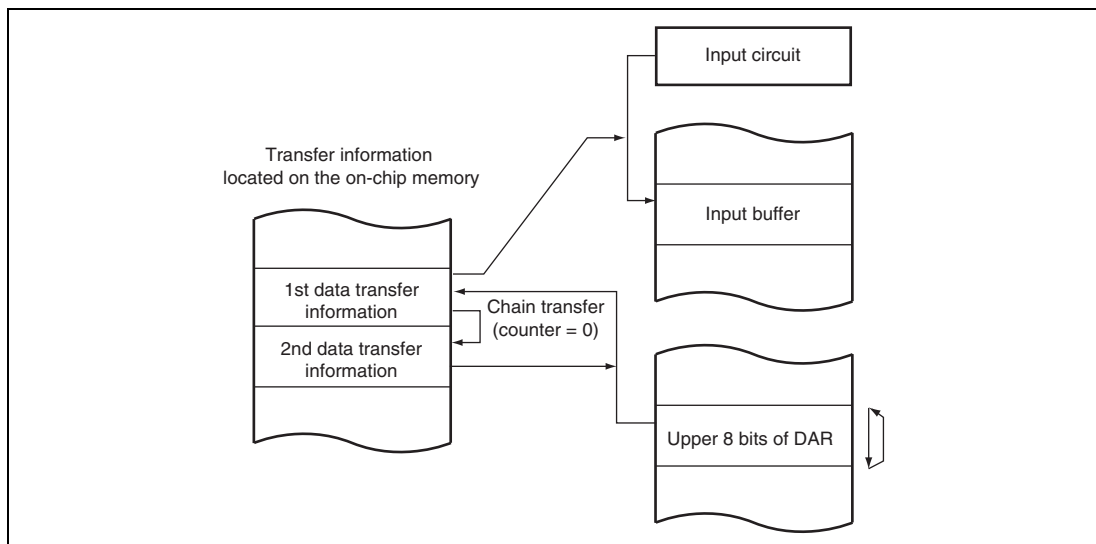

Figure 8.19 Chain Transfer when Counter = 0

8.8 Interrupt Sources

An interrupt request is issued to the CPU when the DTC finishes the specified number of data transfers, or on completion of a single data transfer or a single block data transfer with the DISEL bit set to 1. In the case of interrupt activation, the interrupt set as the activation source is generated. These interrupts to the CPU are subject to CPU mask level and priority level control in the interrupt controller. For details, refer to section 6.8, Data Transfer with Interrupt Request Signals.

8.9 Usage Notes

8.9.1 Module Standby Mode Setting

Operation of the DTC can be disabled or enabled using the standby control register. The initial setting is for operation of the DTC to be disabled. DTC operation is disabled in module standby mode but register access is available. Module standby mode cannot be set while the DTC is activated. Before entering software standby mode or module standby mode, all DTCER registers must be cleared. For details, refer to section 22, Power-Down Modes.

8.9.2 On-Chip RAM

Transfer information can be located in on-chip RAM. In this case, the RAME bit in RAMCR must not be cleared to 0.

8.9.3 DTCE Bit Setting

To set a DTCE bit, disable the corresponding interrupt, read 0 from the bit, and then write 1 to it. While DTC transfer is in progress, do not modify the DTCE bits.

8.9.4 Chain Transfer

When chain transfer is used, clearing of the activation source or DTCER is performed when the last of the chain of data transfers is executed. SCI and A/D converter interrupt/activation sources, on the other hand, are cleared when the DTC reads or writes to the relevant register.

8.9.5 Transfer Information Start Address, Source Address, and Destination Address

The transfer information start address to be specified in the vector table should be address 4n. Transfer information should be placed in on-chip RAM or external memory space.

8.9.6 Access to DTC Registers through DTC

Do not access the DTC registers by using DTC operation.

8.9.7 Notes on IRQ Interrupt as DTC Activation Source

- The IRQ interrupt specified as a DTC activation source must not be used to cancel software standby mode.
- The IRQ edge input in software standby mode must not be specified as a DTC activation source.
- When a low level on the IRQ pin is to be detected, if the end of DTC transfer is used to request an interrupt to the CPU (transfer counter = 0 or DISEL = 1), the IRQ signal must be kept low until the CPU accepts the interrupt.

8.9.8 Notes on SCI as DTC Activation Sources

- When the TXI interrupt from the SCI is specified as a DTC activation source, the TEND flag in the SCI must not be used as the transfer end flag.

8.9.9 Clearing Interrupt Source Flag

The interrupt source flag set when the DTC transfer is completed should be cleared in the interrupt handler in the same way as for general interrupt source flags. For details, refer to section 6.9, Usage Note.

8.9.10 Conflict between NMI Interrupt and DTC Activation

When a conflict occurs between the generation of the NMI interrupt and the DTC activation, the NMI interrupt has priority. Thus the ERR bit is set to 1 and the DTC is not activated.

It takes $1 \times \text{Bcyc} + 3 \times \text{Pcyc}$ for determining DTC stop by NMI, $2 \times \text{Bcyc}$ for determining DTC activation by IRQ, and $1 \times \text{Pcyc}$ for determining DTC activation by peripheral modules.

8.9.11 Operation When a DTC Activation Request Is Cancelled While in Progress

Once the DTC has accepted an activation request, the DTC does not accept the next activation request until the sequence of DTC processing that ends with writeback has been completed.

Section 9 Bus State Controller (BSC)

The bus state controller (BSC) outputs control signals for various types of memory that is connected to the external address space and external devices. BSC functions enable this LSI to connect directly with SRAM and other memory storage devices and external devices.

9.1 Features

1. External address space
 - A maximum 1 Mbyte for each of two areas, CS0 and CS1
 - Can select the data bus width (8 or 16 bits) for each address space
 - Controls the insertion of the wait state for each address space.
 - Controls the insertion of the wait state for each read access and write access
 - Can set the independent idling cycle in the continuous access for five cases: read-write (in same space/different space), read-read (in same space/different space), the first cycle is a write access.
2. Normal space interface
 - Supports the interface that can directly connect to the SRAM

Figure 9.1 shows a block diagram of the BSC.

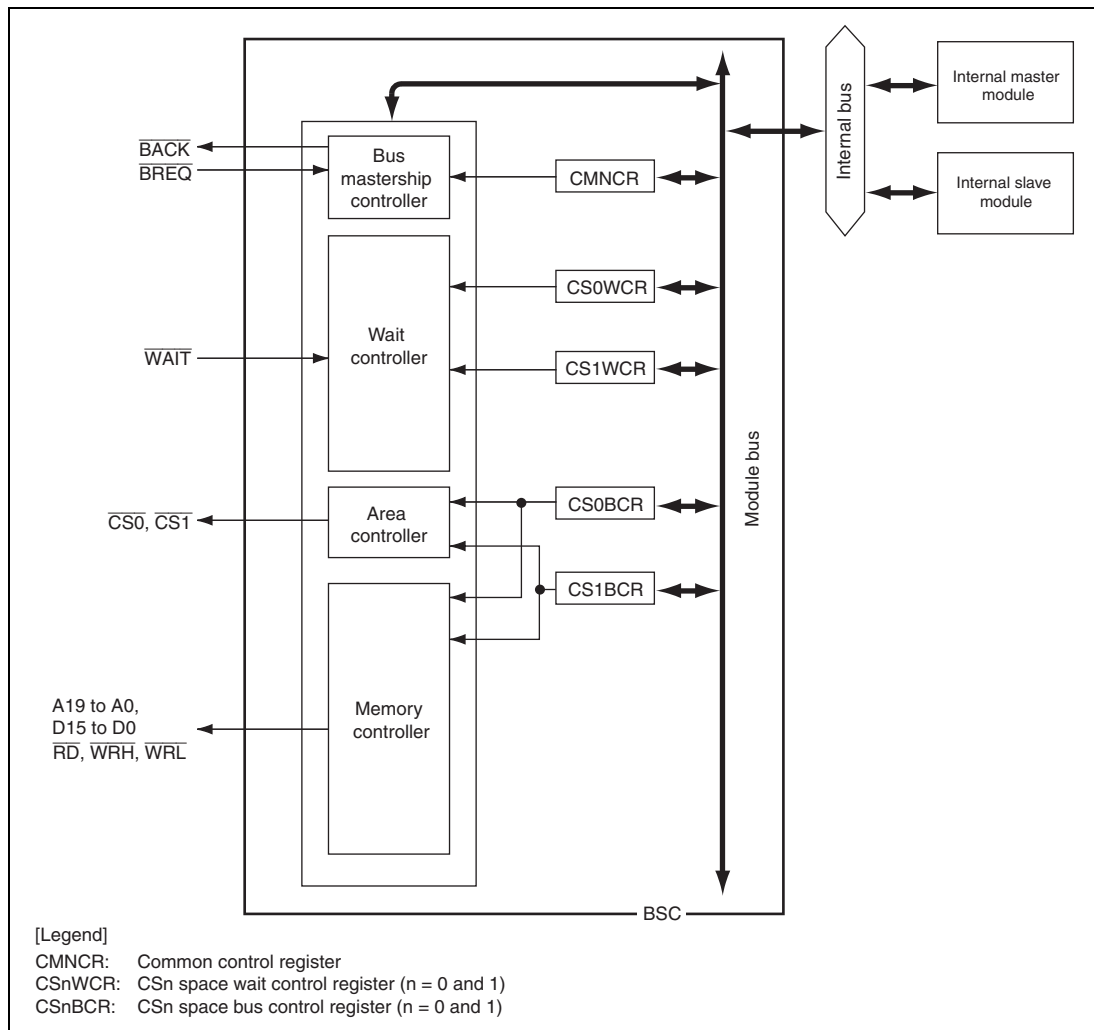

Figure 9.1 Block Diagram of BSC

9.2 Input/Output Pins

The pin configuration of the BSC is listed in table 9.1.

Table 9.1 Pin Configuration

Name	I/O	Function
A19 to A0	Output	Address bus
D15 to D0	I/O	Data bus
$\overline{CS0}$ and $\overline{CS1}$	Output	Chip select
\overline{RD}	Output	Read pulse signal (read data output enable signal)
\overline{WRH}	Output	Indicates byte write through D15 to D8.
\overline{WRL}	Output	Indicates byte write through D7 to D0.
\overline{WAIT}	Input	External wait input
\overline{BREQ}	Input	Bus request input
\overline{BACK}	Output	Bus acknowledge output

9.3 Area Overview

9.3.1 Area Division

In the architecture, this LSI has 32-bit address spaces.

As listed in tables 9.2 to 9.4, this LSI can connect two areas to each type of memory, and it outputs chip select signals ($\overline{CS0}$ and $\overline{CS1}$) for each of them. $\overline{CS0}$ is asserted during area 0 access.

9.3.2 Address Map

The external address space has a capacity of 2 Mbytes and is used by dividing into two spaces. The memory to be connected and the data bus width are specified in each space. The address map for the entire address space is listed in tables 9.2 to 9.4.

Table 9.2 Address Map (Single-Chip Mode)

Address	Area	Memory Type	Capacity	Bus Width
H'00000000 to H'0003FFFF	On-chip ROM		256 kbytes	32 bits
H'00040000 to H'FFFF8FFF	Reserved			
H'FFFF9000 to H'FFFFAFFF	On-chip RAM		8 kbytes	32 bits
H'FFFFB000 to H'FFFFBFFF	Reserved			
H'FFFC000 to H'FFFFFFF	On-chip peripheral modules		16 kbytes	8 or 16 bits

Note: Do not access the reserved area. If the reserved area is accessed, the correct operation cannot be guaranteed. Only the on-chip ROM, on-chip RAM, and on-chip peripheral modules can be accessed; the other areas cannot be accessed.

Table 9.3 Address Map (SH7149 in On-Chip ROM-Enabled Mode)

Address	Area	Memory Type	Capacity	Bus Width
H'00000000 to H'0003FFFF	On-chip ROM		256 kbytes	32 bits
H'00040000 to H'01FFFFFF	Reserved			
H'02000000 to H'020FFFFFFF	CS0 space	Normal space	1 Mbyte	8 or 16 bits*
H'02100000 to H'03FFFFFF	Reserved			
H'04000000 to H'040FFFFFFF	CS1 space	Normal space	1 Mbyte	8 or 16 bits*
H'04100000 to H'FFFF8FFF	Reserved			
H'FFFF9000 to H'FFFFAFFF	On-chip RAM		8 kbytes	32 bits
H'FFFFB000 to H'FFFFBFFF	Reserved			
H'FFFC000 to H'FFFFFFF	On-chip peripheral modules		16 kbytes	8 or 16 bits

Notes: Do not access the reserved area. If the reserved area is accessed, the correct operation cannot be guaranteed. In single-chip mode, only the on-chip ROM, on-chip RAM, and on-chip peripheral modules can be accessed; the other areas cannot be accessed.

* The bus width is selected by the register setting.

Table 9.4 Address Map (SH7149 in On-Chip ROM-Disabled Mode)

Address	Area	Memory Type	Capacity	Bus Width
H'00000000 to H'000FFFFFFF	CS0 space	Normal space	1 Mbyte	8 or 16 bits* ¹
H'001FFFFFFF to H'03FFFFFFF	Reserved			
H'04000000 to H'040FFFFFFF	CS1 space	Normal space	1 Mbyte	8 or 16 bits* ²
H'04100000 to H'FFFF8FFF	Reserved			
H'FFFF9000 to H'FFFFAFFF	On-chip RAM		8 kbytes	32 bits
H'FFFFB000 to H'FFFFBFFF	Reserved			
H'FFFC000 to H'FFFFFFF	On-chip peripheral modules		16 kbytes	8 or 16 bits

Notes: Do not access the reserved area. If the reserved area is accessed, the correct operation cannot be guaranteed.

1. The bus width is selected by the mode pins.
2. The bus width is selected by the register setting.

9.4 Register Descriptions

The BSC has the following registers. Refer to section 23, List of Registers, for details on the register addresses and register states in each operating mode.

Do not access spaces other than CS0 until the termination of the memory interface setting.

Table 9.5 Register Configuration

Register Name	Abbrevia- tion	R/W	Initial Value	Address	Access Size
Common control register	CMNCR	R/W	H'00001010	H'FFFFFF00	32
CS0 space bus control register	CS0BCR	R/W	H'36DB0600	H'FFFFFF04	32
CS1 space bus control register	CS1BCR	R/W	H'36DB0600	H'FFFFFF08	32
CS0 space wait control register	CS0WCR	R/W	H'00000500	H'FFFFFF28	32
CS1 space wait control register	CS1WCR	R/W	H'00000500	H'FFFFFF2C	32
Bus function extending register	BSCEHR	R/W	H'0000	H'FFFE89A	8, 16

9.4.1 Common Control Register (CMNCR)

CMNCR is a 32-bit register that controls the common items for each area.

Do not access external memory other than area 0 until the register initialization is complete.

Bit:	31	30	29	28	27	26	25	24	23	22	21	20	19	18	17	16
	-	-	-	-	-	-	-	-	-	-	-	-	-	-	-	-
Initial value:	0	0	0	0	0	0	0	0	0	0	0	0	0	0	0	0
R/W:	R	R	R	R	R	R	R	R	R	R	R	R	R	R	R	R
Bit:	15	14	13	12	11	10	9	8	7	6	5	4	3	2	1	0
	-	-	-	-	-	-	-	-	-	-	-	-	-	-	HIZMEM	-
Initial value:	0	0	0	1	0	0	0	0	0	0	0	1	0	0	0	0
R/W:	R	R	R	R	R	R	R	R	R	R	R	R	R	R	R/W	R

Bit	Bit Name	Initial Value	R/W	Description
31 to 13	—	All 0	R	Reserved These bits are always read as 0. The write value should always be 0.
12	—	1	R	Reserved This bit is always read as 1. The write value should always be 1.
11 to 5	—	All 0	R	Reserved These bits are always read as 0. The write value should always be 0.
4	—	1	R	Reserved This bit is always read as 1. The write value should always be 1.
3, 2	—	All 0	R	Reserved These bits are always read as 0. The write value should always be 0.
1	HIZMEM	0	R/W	Hi-Z Memory Control Specifies the pin state in software standby mode for A19 to A0, CSn, WRxx, and RD. While the bus is released, these pins are in high-impedance state regardless of this bit setting. 0: High impedance in software standby mode 1: Driven in software standby mode
0	—	0	R	Reserved This bit is always read as 0. The write value should always be 0.

9.4.2 CSn Space Bus Control Register (CSnBCR) (n = 0 and 1)

CSnBCR is a 32-bit readable/writable register that specifies the data bus width of the respective space, and the number of wait cycles between access cycles.

Do not access external memory other than area 0 until the register initialization is complete.

Bit:	31	30	29	28	27	26	25	24	23	22	21	20	19	18	17	16
	-	-	IWW[1:0]	-	IWRWD[1:0]	-	IWRWS[1:0]	-	IWRRD[1:0]	-	IWRRS[1:0]	-	-	-	-	-
Initial value:	0	0	1	1	0	1	1	0	1	1	0	1	1	0	1	1
R/W:	R	R	R/W	R/W	R	R/W	R/W	R	R/W	R/W	R	R/W	R/W	R	R/W	R/W
Bit name:	15	14	13	12	11	10	9	8	7	6	5	4	3	2	1	0
	-	-	-	-	-	BSZ[1:0]	-	-	-	-	-	-	-	-	-	-
Initial value:	0	0	0	0	0	1*	1*	0	0	0	0	0	0	0	0	0
R/W:	R	R	R	R	R	R/W	R/W	R	R	R	R	R	R	R	R	R

Note: * When the on-chip ROM is disabled, CS0BCR samples the value input through the MD0 and MD1 external pins that specify the bus width when a power-on reset is performed.

Bit	Bit Name	Initial Value	R/W	Description
31, 30	—	All 0	R	Reserved These bits are always read as 0. The write value should always be 0.
29, 28	IWW[1:0]	11	R/W	Specification for Idle Cycles between Write-Read/Write-Write Cycles Specify the number of idle cycles to be inserted after access to memory that is connected to the space. The target cycles are write-read cycles and write-write cycles. 00: No idle cycle inserted 01: 1 idle cycle inserted 10: 2 idle cycles inserted 11: 4 idle cycles inserted
27	—	0	R	Reserved This bit is always read as 0. The write value should always be 0.

Bit	Bit Name	Initial Value	R/W	Description
26, 25	IWRWD[1:0]	11	R/W	<p>Specification for Idle Cycles between Read-Write Cycles in Different Spaces</p> <p>Specify the number of idle cycles to be inserted after access to memory that is connected to the space. The target cycles are continuous read-write cycles in different spaces.</p> <p>00: No idle cycle inserted 01: 1 idle cycle inserted 10: 2 idle cycles inserted 11: 4 idle cycles inserted</p>
24	—	0	R	<p>Reserved</p> <p>This bit is always read as 0. The write value should always be 0.</p>
23, 22	IWRWS[1:0]	11	R/W	<p>Specification for Idle Cycles between Read-Write Cycles in the Same Space</p> <p>Specify the number of idle cycles to be inserted after access to memory that is connected to the space. The target cycles are continuous read-write cycles in the same space.</p> <p>00: No idle cycle inserted 01: 1 idle cycle inserted 10: 2 idle cycles inserted 11: 4 idle cycles inserted</p>
21	—	0	R	<p>Reserved</p> <p>This bit is always read as 0. The write value should always be 0.</p>
20, 19	IWRRD[1:0]	11	R/W	<p>Specification for Idle Cycles between Read-Read Cycles in Different Spaces</p> <p>Specify the number of idle cycles to be inserted after access to memory that is connected to the space. The target cycles are continuous read-read cycles in different spaces.</p> <p>00: No idle cycle inserted 01: 1 idle cycle inserted 10: 2 idle cycles inserted 11: 4 idle cycles inserted</p>

Bit	Bit Name	Initial Value	R/W	Description
18	—	0	R	Reserved This bit is always read as 0. The write value should always be 0.
17, 16	IWRRS[1:0]	11	R/W	Specification for Idle Cycles between Read-Read Cycles in the Same Space Specify the number of idle cycles to be inserted after access to memory that is connected to the space. The target cycles are continuous read-read cycles in the same space. 00: No idle cycle inserted 01: 1 idle cycle inserted 10: 2 idle cycles inserted 11: 4 idle cycles inserted
15 to 11	—	All 0	R	Reserved These bits are always read as 0. The write value should always be 0.
10, 9	BSZ[1:0]	11*	R/W	Data Bus Size Specification Specify the data bus sizes of spaces. 00: Setting prohibited 01: 8-bit size 10: 16-bit size 11: Setting prohibited Note: When the on-chip ROM is disabled, the data bus width in area 0 is specified through external input pins. The BSZ1 and BSZ0 bit setting in CS0BCR is ignored.
8 to 0	—	All 0	R	Reserved These bits are always read as 0. The write value should always be 0.

Note: * When the on-chip ROM is disabled, CS0BCR samples the value input through the MD0 and MD1 external pins that specify the bus width when a power-on reset is performed.

9.4.3 CSn Space Wait Control Register (CSnWCR) (n = 0 and 1)

CSnWCR specifies various wait cycles for memory accesses. Specify CSnWCR before accessing the target area. CSnWCR should be modified only after CSnBCR setting is completed.

Bit:	31	30	29	28	27	26	25	24	23	22	21	20	19	18	17	16
	-	-	-	-	-	-	-	-	-	-	-	-	-	-	WW[2:0]	
Initial value:	0	0	0	0	0	0	0	0	0	0	0	0	0	0	0	0
R/W:	R	R	R	R	R	R	R	R	R	R	R	R	R	R/W	R/W	R/W

Bit:	15	14	13	12	11	10	9	8	7	6	5	4	3	2	1	0
	-	-	-	SW[1:0]		WR[3:0]				WM	-	-	-	-	HW[1:0]	
Initial value:	0	0	0	0	0	1	0	1	0	0	0	0	0	0	0	0
R/W:	R	R	R	R/W	R/W	R/W	R/W	R/W	R/W	R/W	R	R	R	R	R/W	R/W

Bit	Bit Name	Initial Value	R/W	Description
31 to 19	—	All 0	R	Reserved These bits are always read as 0. The write value should always be 0.
18 to 16	WW[2:0]	000	R/W	Number of Wait Cycles in Write Access Specify the number of cycles required for write access. 000: The same cycles as WR3 to WR0 settings (read access wait) 001: 0 cycles 010: 1 cycle 011: 2 cycles 100: 3 cycles 101: 4 cycles 110: 5 cycles 111: 6 cycles
15 to 13	—	All 0	R	Reserved These bits are always read as 0. The write value should always be 0.

Bit	Bit Name	Initial Value	R/W	Description
12, 11	SW[1:0]	00	R/W	<p>Number of Delay Cycles from Address and CSn Assertion to RD and WRxx Assertion</p> <p>Specify the number of delay cycles from address and CSn assertion to RD and WRxx assertion.</p> <p>00: 0.5 cycle 01: 1.5 cycles 10: 2.5 cycles 11: 3.5 cycles</p>
10 to 7	WR[3:0]	1010	R/W	<p>Number of Read Access Wait Cycles</p> <p>Specify the number of wait cycles required for read access.</p> <p>0000: 0 cycles 0001: 1 cycle 0010: 2 cycles 0011: 3 cycles 0100: 4 cycles 0101: 5 cycles 0110: 6 cycles 0111: 8 cycles 1000: 10 cycles 1001: 12 cycles 1010: 14 cycles 1011: 18 cycles 1100: 24 cycles 1101: Reserved (setting prohibited) 1110: Reserved (setting prohibited) 1111: Reserved (setting prohibited)</p>
6	WM	0	R/W	<p>External Wait Mask Specification</p> <p>Specifies whether or not the external wait input is valid. The specification by this bit is valid even when the number of access wait cycles is 0.</p> <p>0: External wait input is valid 1: External wait input is ignored</p>

Bit	Bit Name	Initial Value	R/W	Description
5 to 2	—	All 0	R	Reserved These bits are always read as 0. The write value should always be 0.
1, 0	HW[1:0]	00	R/W	Delay Cycles from \overline{RD} and \overline{WRxx} Negation to Address and \overline{CSn} Negation Specify the number of delay cycles from \overline{RD} and \overline{WRxx} negation to address and \overline{CSn} negation. 00: 0.5 cycle 01: 1.5 cycles 10: 2.5 cycles 11: 3.5 cycles

9.4.4 Bus Function Extending Register (BSCEHR)

BSCEHR is a 16-bit register that specifies the timing of bus release by the DTC. It also specifies the application of priority in transfer operations and enables or disables the functions that have the effect of decreasing numbers of cycles over which the DTC is active. The differences in DTC operation made by the combinations of the DTLOCK, CSSTP1, and DTBST bits settings are described in section 8.5.9, DTC Bus Releasing Timing.

Setting the CSSTP2 bit can improve the transfer performance of the DTC transfer when the DTLOCK bit is 0. Furthermore, setting the CSSTP3 bit selects whether or not access to the external space by the CPU takes priority over DTC transfer.

The DTC short address mode is implemented by setting the DTSA bit. For details of the short address mode, see section 8.4, Location of Transfer Information and DTC Vector Table.

A DTC activation priority order can be set up for the DTC activation sources. The DTPR bit selects whether or not this priority order is valid or invalid when multiple sources issue activation requests before DTC activation. Do not modify this register while the DTC is active.

Bit:	15	14	13	12	11	10	9	8	7	6	5	4	3	2	1	0
	DTLOCK	CSSTP1	-	CSSTP2	DTBST	DTSA	CSSTP3	DTPR	-	-	-	-	-	-	-	-
Initial value:	0	0	0	0	0	0	0	0	0	0	0	0	0	0	0	0
R/W:	R/W	R/W	R	R/W	R/W	R/W	R/W	R/W	R	R	R	R	R	R	R	R

Bit	Bit Name	Initial Value	R/W	Description
15	DTLOCK	0	R/W	<p>DTC Lock Enable</p> <p>Specifies the timing of bus release by the DTC.</p> <p>0: The DTC releases the bus on generation of the NOP cycle that follows vector read or write-back of transfer information.</p> <p>1: The DTC releases the bus after vector read, on generation of the NOP cycle that follows vector read, after transfer information read, after a round of data transfer, or after write-back of transfer information.</p>
14	CSSTP1	0	R/W	<p>Select Bus Release on NOP Cycle Generation by DTC</p> <p>Specifies whether or not the bus is released in response to requests from the CPU for external space access on generation of the NOP cycle that follows reading of the vector address.</p> <p>If, however, the CSSTP2 bit is 1, bus mastership is retained until all transfer is complete, regardless of the setting of this bit.</p> <p>0: The bus is released on generation of the NOP cycle by the DTC.</p> <p>1: The bus is not released on generation of the NOP cycle by the DTC.</p>
13	—	0	R	<p>Reserved</p> <p>This bit is always read as 0. The write value should always be 0.</p>
12	CSSTP2	0	R/W	<p>Select Bus Release during DTC Transfer</p> <p>This setting applies to DTC transfer when the DTLOCK bit is 0. The value specifies whether the bus mastership is or is not to be released after each round of transfer in response to a request from the CPU for access to the external space.</p> <p>0: When the DTLOCK and CSSTP1 bits are 0, the bus is released on generation of the NOP cycle after reading of the vector address. When the DTLOCK bit is 0 and the CSSTP1 bit is 1, the bus is released after each round of data transfer.</p> <p>1: Only release the bus mastership after all data transfer is complete.</p>

Bit	Bit Name	Initial Value	R/W	Description
11	DTBST	0	R/W	<p>DTC Burst Enable</p> <p>Selects whether or not the DTC retains the bus mastership and remains continuously active until all transfer operations are complete when multiple DTC activation requests have been generated.</p> <p>0: Release the bus on the completion of transfer for each individual DTC activation source.</p> <p>1: Keep the DTC continuously active, i.e. only release the bus on completion of processing for all DTC activation sources.</p> <p>Notes: When this bit is set to 1, the following restrictions apply.</p> <ol style="list-style-type: none"> 1. Clock setting with the frequency control register (FRQCR) must be $I\phi: B\phi: P\phi: M\phi: MP\phi = 8: 4: 4: 4: 4, 4: 2: 2: 2: 2$, or $2: 1: 1: 1: 1$ 2. The vector information must be in on-chip ROM or on-chip RAM. 3. The transfer information must be in on-chip RAM. 4. Transfer must be between the on-chip RAM and an on-chip peripheral module or between external memory and an on-chip peripheral module.
10	DTSA	0	R/W	<p>DTC Short Address Mode</p> <p>In this mode, the information that specifies a DTC transfer takes up only 3 longwords.</p> <p>0: Transfer information is read out as 4 longwords. The transfer information is arranged as shown in figure 8.2 (normal address mode).</p> <p>1: Transfer information is read out as 3 longwords. The transfer information is arranged as shown in figure 8.2 (short address mode).</p> <p>Note: Transfer in short address mode is only available between on-chip peripheral modules and on-chip RAM, because the higher-order 8 bits of the SAR and DAR are considered to be all 1.</p>

Bit	Bit Name	Initial Value	R/W	Description
9	CSSTP3	0	R/W	<p>Select Priority for External Memory Access by CPU</p> <p>Specifies whether or not access to the external space by the CPU takes priority over DTC transfer.</p> <p>0: DTC transfer has priority.</p> <p>1: External space access from the CPU has priority.</p> <p>Note: When this bit is 0, and access to internal I/O from the CPU is immediately followed by access to external space from the CPU, a NOP 1Bϕ in duration is inserted between the two access cycles.</p>
8	DTPR	0	R/W	<p>Application of Priority in DTC Activation</p> <p>When multiple DTC activation requests are generated before the DTC is activated, specify whether transfer starts from the first request to have been generated or is in accord with the priority order for DTC activation requests.</p> <p>However, when multiple DTC activation requests have been issued while the DTC is active, the next transfer to be triggered will be that with the highest DTC activation priority.</p> <p>0: Start transfer in response to the first request to have been generated.</p> <p>1: Start transfer in accord with DTC activation request priority.</p> <p>Notes: When this bit is set to 1, the following restrictions apply.</p> <ol style="list-style-type: none"> 1. The vector information must be in on-chip ROM or on-chip RAM. 2. The transfer information must be in on-chip RAM. 3. Skipping of transfer information reading is always disabled.
7 to 0	—	All 0	R	<p>Reserved</p> <p>These bits are always read as 0. The write value should always be 0.</p>

9.5 Operation

9.5.1 Endian/Access Size and Data Alignment

This LSI supports big endian, in which the 0 address is the most significant byte (MSB) in the byte data.

Two data bus widths (8 bits and 16 bits) are available. Data alignment is performed in accordance with the data bus width of the respective device. This also means that when longword data is read from a byte-width device, the read operation must be done four times. In this LSI, data alignment and conversion of data length are performed automatically between the respective interfaces.

Tables 9.6 and 9.7 show the relationship between device data width and access unit.

Table 9.6 16-Bit External Device Access and Data Alignment

Operation	Data Bus		Strobe Signals		
	D15 to D8	D7 to D0	\overline{WRH}	\overline{WRL}	
Byte access at 0	Data 7 to Data 0	—	Assert	—	
Byte access at 1	—	Data 7 to Data 0	—	Assert	
Byte access at 2	Data 7 to Data 0	—	Assert	—	
Byte access at 3	—	Data 7 to Data 0	—	Assert	
Word access at 0	Data 15 to Data 8	Data 7 to Data 0	Assert	Assert	
Word access at 2	Data 15 to Data 8	Data 7 to Data 0	Assert	Assert	
Longword access at 0	1st time at 0	Data 31 to Data 24	Data 23 to Data 16	Assert	Assert
	2nd time at 2	Data 15 to Data 8	Data 7 to Data 0	Assert	Assert

Table 9.7 8-Bit External Device Access and Data Alignment

Operation		Data Bus		Strobe Signals	
		D15 to D8	D7 to D0	\overline{WRH}	\overline{WRL}
Byte access at 0		—	Data 7 to Data 0	—	Assert
Byte access at 1		—	Data 7 to Data 0	—	Assert
Byte access at 2		—	Data 7 to Data 0	—	Assert
Byte access at 3		—	Data 7 to Data 0	—	Assert
Word access at 0	1st time at 0	—	Data 15 to Data 8	—	Assert
	2nd time at 1	—	Data 7 to Data 0	—	Assert
Word access at 2	1st time at 2	—	Data 15 to Data 8	—	Assert
	2nd time at 3	—	Data 7 to Data 0	—	Assert
Longword access at 0	1st time at 0	—	Data 31 to Data 24	—	Assert
	2nd time at 1	—	Data 23 to Data 16	—	Assert
	3rd time at 2	—	Data 15 to Data 8	—	Assert
	4th time at 3	—	Data 7 to Data 0	—	Assert

9.5.2 Normal Space Interface

Basic Timing: For access to a normal space, this LSI uses strobe signal output in consideration of the fact that mainly SRAM without a byte selection will be directly connected. Figure 9.2 shows the basic timings of normal space access. A no-wait normal access is completed in two cycles.

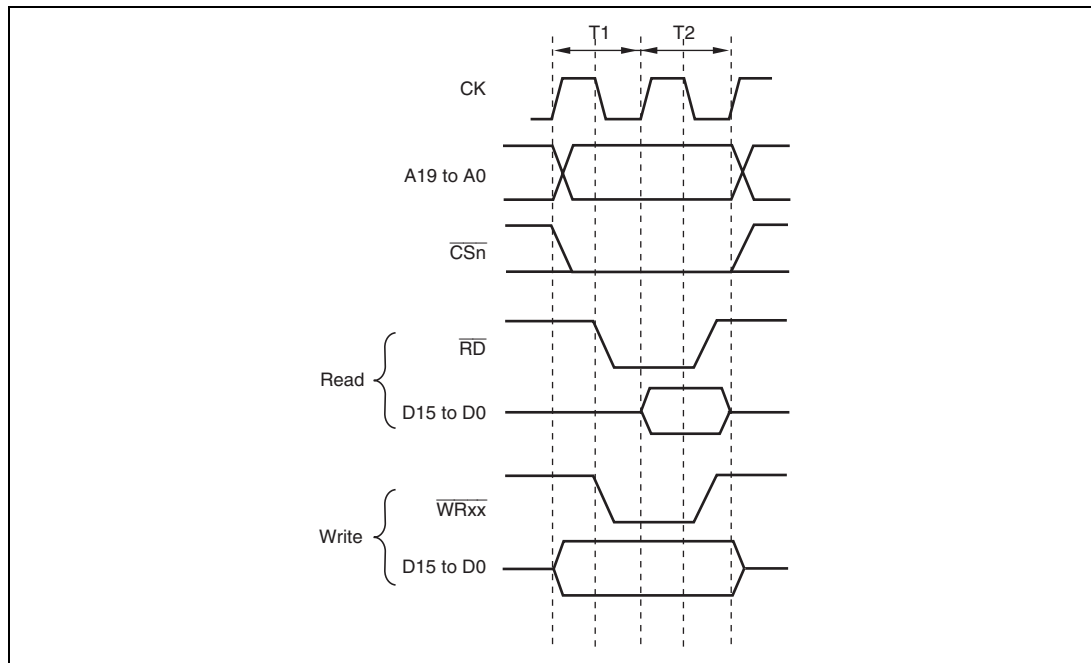

Figure 9.2 Normal Space Basic Access Timing (Access Wait 0)

There is no access size specification when reading. The correct access start address is output in the least significant bit of the address, but since there is no access size specification, 16 bits are always read in a 16-bit device. When writing, only the \overline{WRxx} signal for the byte to be written is asserted.

It is necessary to control of outputting the data that has been read using \overline{RD} when a buffer is established in the data bus.

Figures 9.3 and 9.4 show the basic timings of continuous accesses to normal space. If the WM bit in CSnWCR is cleared to 0, a Tnop cycle is inserted to evaluate the external wait (figure 9.3). If the WM bit in CSnWCR is set to 1, external waits are ignored and no Tnop cycle is inserted (figure 9.4).

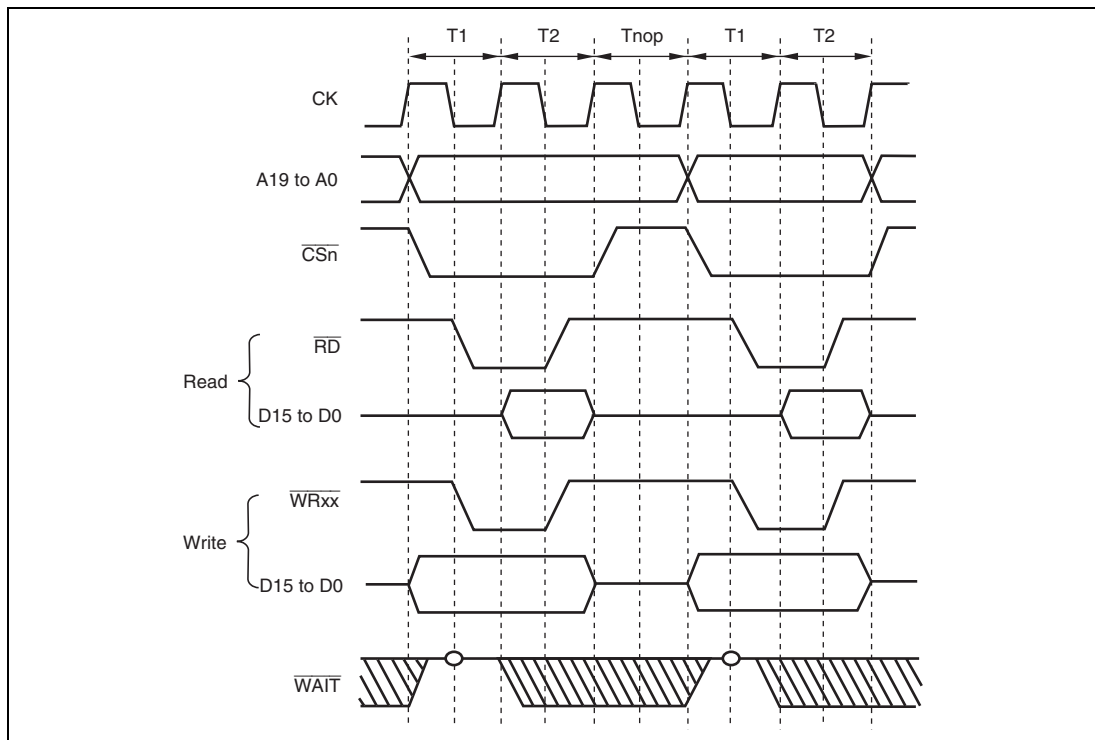

Figure 9.3 Continuous Access for Normal Space 1
Bus Width = 16 Bits, Longword Access, WM Bit in CSnWCR = 0
(Access Wait = 0, Cycle Wait = 0)

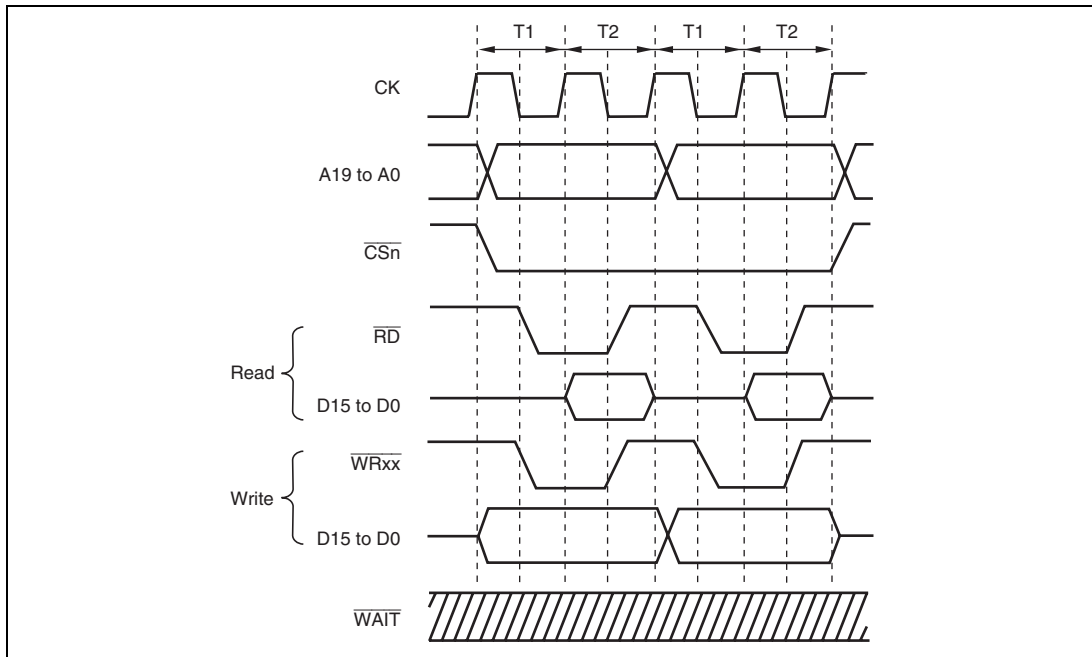

Figure 9.4 Continuous Access for Normal Space 2
Bus Width = 16 Bits, Longword Access, WM Bit in CSnWCR = 1
(Access Wait = 0, Cycle Wait = 0)

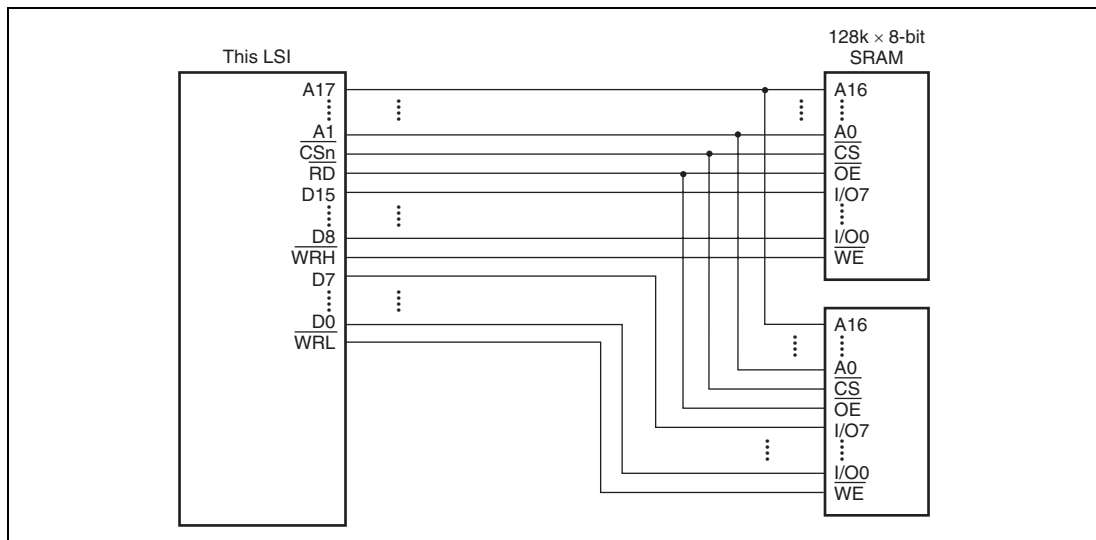

Figure 9.5 Example of 16-Bit Data-Width SRAM Connection

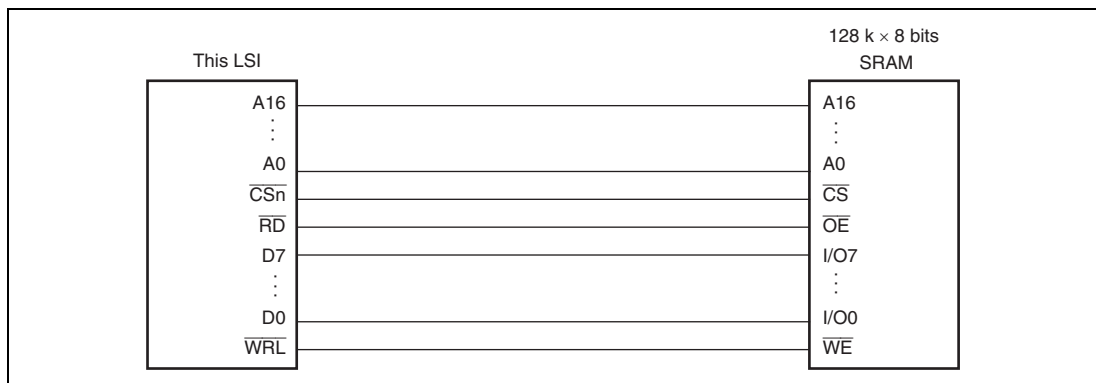

Figure 9.6 Example of 8-Bit Data-Width SRAM Connection

9.5.3 Access Wait Control

Wait cycle insertion on a normal space access can be controlled by the settings of bits WR3 to WR0 in CSnWCR. It is possible to insert wait cycles independently in read access and in write access. The specified number of T_w cycles is inserted as wait cycles in a normal space access shown in figure 9.7.

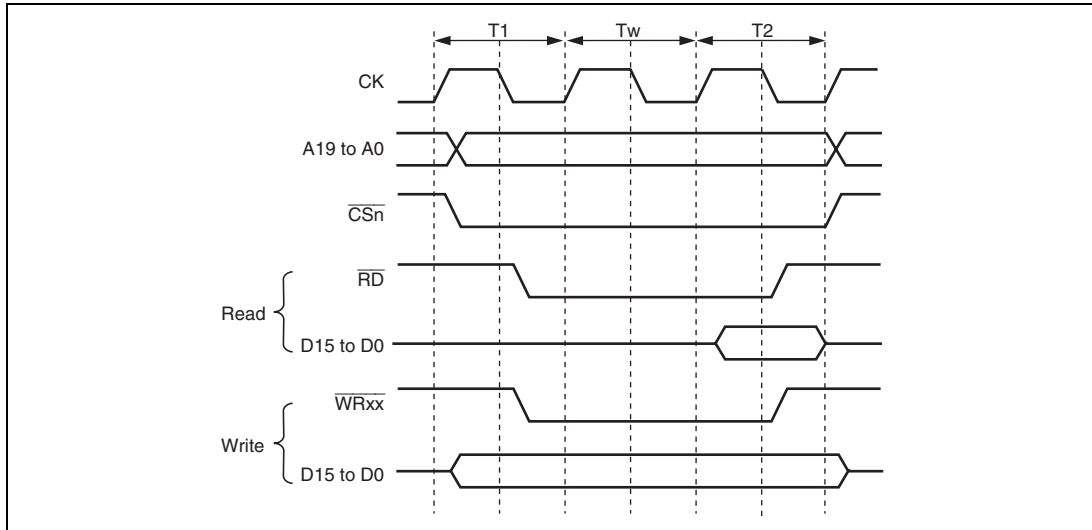
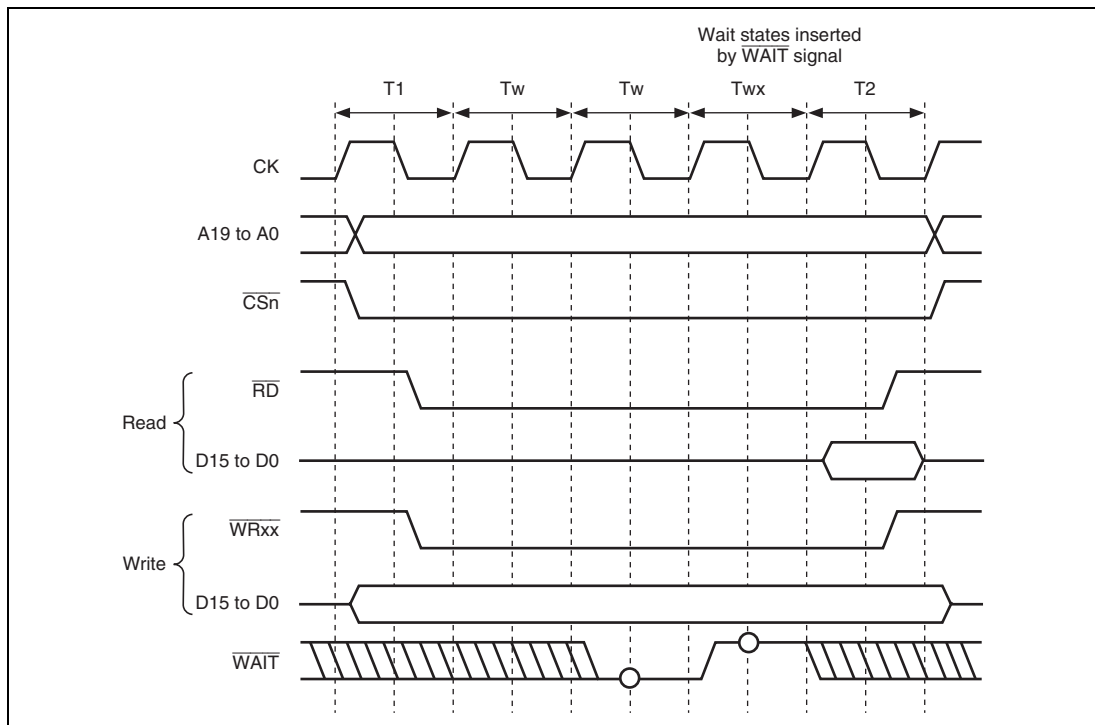

Figure 9.7 Wait Timing for Normal Space Access (Software Wait Only)

When the WM bit in CSnWCR is cleared to 0, the external wait input $\overline{\text{WAIT}}$ signal is also sampled. $\overline{\text{WAIT}}$ pin sampling is shown in figure 9.8. A 2-cycle wait is specified as a software wait. The $\overline{\text{WAIT}}$ signal is sampled at the falling edge of CK at the transition from the T1 or Tw cycle to the T2 cycle.



**Figure 9.8 Wait State Timing for Normal Space Access
(Wait State Insertion Using $\overline{\text{WAIT}}$ Signal)**

9.5.4 \overline{CSn} Assert Period Extension

The number of cycles from \overline{CSn} assertion to \overline{RD} , \overline{WRxx} assertion can be specified by setting bits SW1 and SW0 in CSnWCR. The number of cycles from \overline{RD} , \overline{WRxx} negation to \overline{CSn} negation can be specified by setting bits HW1 and HW0. Therefore, a flexible interface to an external device can be obtained. Figure 9.9 shows an example. A T_h cycle and a T_f cycle are added before and after an ordinary cycle, respectively. In these cycles, \overline{RD} and \overline{WRxx} are not asserted, while other signals are asserted. The data output is prolonged to the T_f cycle, and this prolongation is useful for devices with slow writing operations.

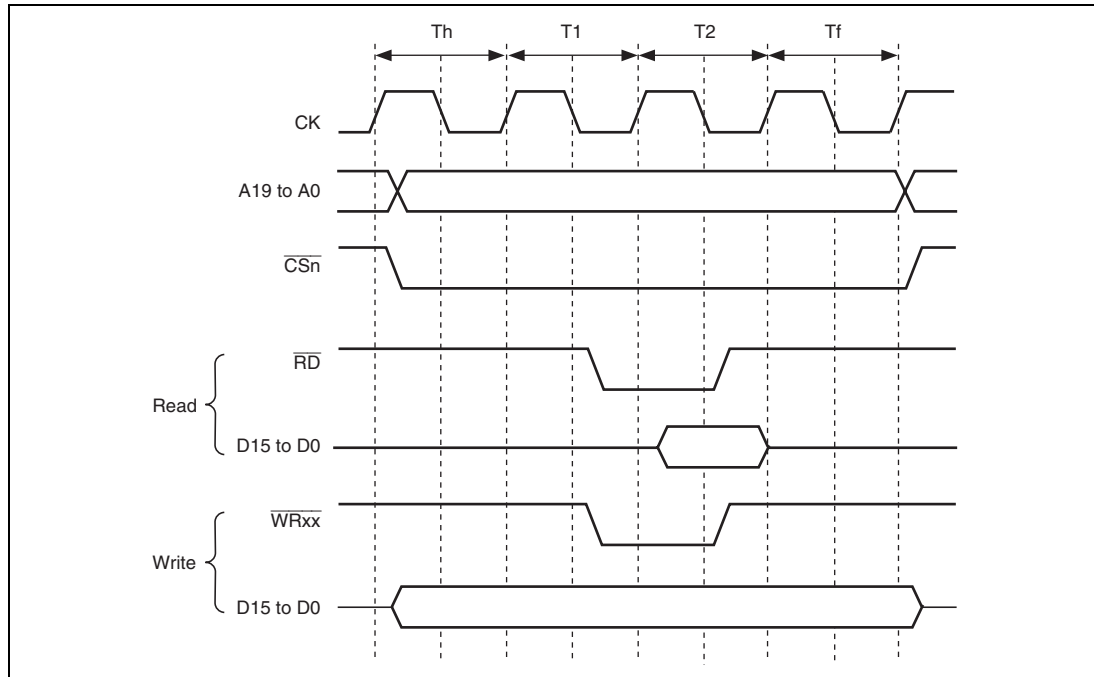

Figure 9.9 \overline{CSn} Assert Period Extension

9.5.5 Wait between Access Cycles

As the operating frequency of LSIs becomes higher, the off-operation of the data buffer often collides with the next data output when the data output from devices with slow access speed is completed. As a result of these collisions, the reliability of the device is low and malfunctions may occur. A function that avoids data collisions by inserting wait cycles between continuous access cycles has been newly added.

The number of wait cycles between access cycles can be set by bits IWW[1:0], IWRWD[1:0], IWRWS[1:0], IWRRD[1:0], and IWRRS[1:0] in CSnBCR. The conditions for setting the wait cycles between access cycles (idle cycles) are shown below.

1. Continuous accesses are write-read or write-write
2. Continuous accesses are read-write for different spaces
3. Continuous accesses are read-write for the same space
4. Continuous accesses are read-read for different spaces
5. Continuous accesses are read-read for the same space

Besides the wait cycles between access cycles (idle cycles) described above, idle cycles must be inserted to reserve the minimum pulse width for a multiplexed pin (\overline{WRxx}), and an interface with an internal bus.

6. Idle cycle of the external bus for the interface with the internal bus
 - A. Insert one idle cycle immediately before a write access cycle after an external bus idle cycle or a read cycle.
 - B. Insert one idle cycle to transfer the read data to the internal bus when a read cycle of the external bus terminates.

Insert two to three idle cycles including the idle cycle in A. for the write cycle immediately after a read cycle.

Tables 9.8 and 9.9 list the minimum number of idle cycles to be inserted. The CSnBCR Idle Setting column in the tables describes the number of idle cycles to be set for IWW, IWRWD, IWRWS, IWRRD, and IWRRS.

Table 9.8 Minimum Number of Idle Cycles between CPU Access Cycles in Normal Space Interface

BSC Register Setting		When Access Size is Less than Bus Width				When Access Size Exceeds Bus Width						
		Read to Read	Write to Write	Read to Write	Write to Read	Contin-uous Read* ¹	Contin-uous Write* ¹	Read to Read* ²	Write to Write* ²	Read to Write* ²	Write to Read* ²	
CSnWCR WM Setting	CSnBCR Idle Setting											
1	0	1/1/1/1	0/0/0/0	3/3/3/4	0/0/0/0	0/0/0/0	0/0/0/0	1/1/1/1	0/0/0/0	3/3/3/4	0/0/0/0	
0	0	1/1/1/1	1/1/1/1	3/3/3/4	1/1/1/1	1/1/1/1	1/1/1/1	1/1/1/1	1/1/1/1	3/3/3/4	1/1/1/1	
1	1	1/1/1/1	1/1/1/1	3/3/3/4	1/1/1/1	1/1/1/1	1/1/1/1	1/1/1/1	1/1/1/1	3/3/3/4	1/1/1/1	
0	1	1/1/1/1	1/1/1/1	3/3/3/4	1/1/1/1	1/1/1/1	1/1/1/1	1/1/1/1	1/1/1/1	3/3/3/4	1/1/1/1	
1	2	2/2/2/2	2/2/2/2	3/3/3/4	2/2/2/2	2/2/2/2	2/2/2/2	2/2/2/2	2/2/2/2	3/3/3/4	2/2/2/2	
0	2	2/2/2/2	2/2/2/2	3/3/3/4	2/2/2/2	2/2/2/2	2/2/2/2	2/2/2/2	2/2/2/2	3/3/3/4	2/2/2/2	
1	4	4/4/4/4	4/4/4/4	4/4/4/4	4/4/4/4	4/4/4/4	4/4/4/4	4/4/4/4	4/4/4/4	4/4/4/4	4/4/4/4	
0	4	4/4/4/4	4/4/4/4	4/4/4/4	4/4/4/4	4/4/4/4	4/4/4/4	4/4/4/4	4/4/4/4	4/4/4/4	4/4/4/4	

Notes: The minimum numbers of idle cycles are described sequentially for I_φ:B_φ = 4:1, 3:1, 2:1, and 1:1.

1. Minimum number of idle cycles between the word access to address 0 and the word access to address 2 in the 32-bit access with a 16-bit bus width, minimum number of idle cycles between the byte access to address 0 and the byte access to address 1 in the 16-bit access with an 8-bit bus width, and minimum number of idle cycles between the byte accesses to address 0, to address 1, to address 2, and to address 3 in the 32-bit access with an 8-bit bus width.
2. Other than the above cases

Table 9.9 Minimum Number of Idle Cycles between Access Cycles during DTC Transfer for the Normal Space Interface

BSC Register Setting		When Access Size is Less than Bus Width		When Access Size Exceeds Bus Width			
CSnWCR. WM Setting	CSnBCR Idle Setting	Read to Write	Write to Read	Continuous Read* ¹	Read to Write* ²	Continuous Write* ¹	Write to Read* ²
1	0	2	0	0	2	0	0
0	0	2	1	1	2	1	1
1	1	2	1	1	2	1	1
0	1	2	1	1	2	1	1
1	2	2	2	2	2	2	2
0	2	2	2	2	2	2	2
1	4	4	4	4	4	4	4
0	4	4	4	4	4	4	4

Notes: DTC is operated by B ϕ . The minimum number of idle cycles is not affected by changing a clock ratio.

1. Minimum number of idle cycles between the word access to address 0 and the word access to address 2 in the 32-bit access with a 16-bit bus width, minimum number of idle cycles between the byte access to address 0 and the byte access to address 1 in the 16-bit access with an 8-bit bus width, and minimum number of idle cycles between the byte accesses to address 0, to address 1, to address 2, and to address 3 in the 32-bit access with an 8-bit bus width.
2. Other than the above cases.

9.5.6 Bus Arbitration

This LSI owns the bus mastership in normal state and releases the bus only when receiving a bus request from an external device. This LSI has two bus masters: CPU and DTC. The bus mastership is given to these bus masters in accordance with the following priority.

Request for bus mastership by external device ($\overline{\text{BREQ}}$) > CPU > DTC > CPU

However, when DTC is requesting the bus mastership, the CPU does not obtain the bus mastership continuously.

When the CSSTP2 bit is 1 in the bus function extending register (BSCHER), the external space access request from the CPU has lower priority than the DTC transfer request with DTLOCK = 0 in the bus function extending register (BSCHER).

In addition, because the write buffer operates as described in section 9.5.7 (2), Access in View of LSI Internal Bus Master, arbitration between the CPU and DTC is different depending on whether the external space access by the CPU is a write or read access. Figure 9.10 shows the bus arbitration when a DTC activation request is generated while an external space is accessed by the CPU.

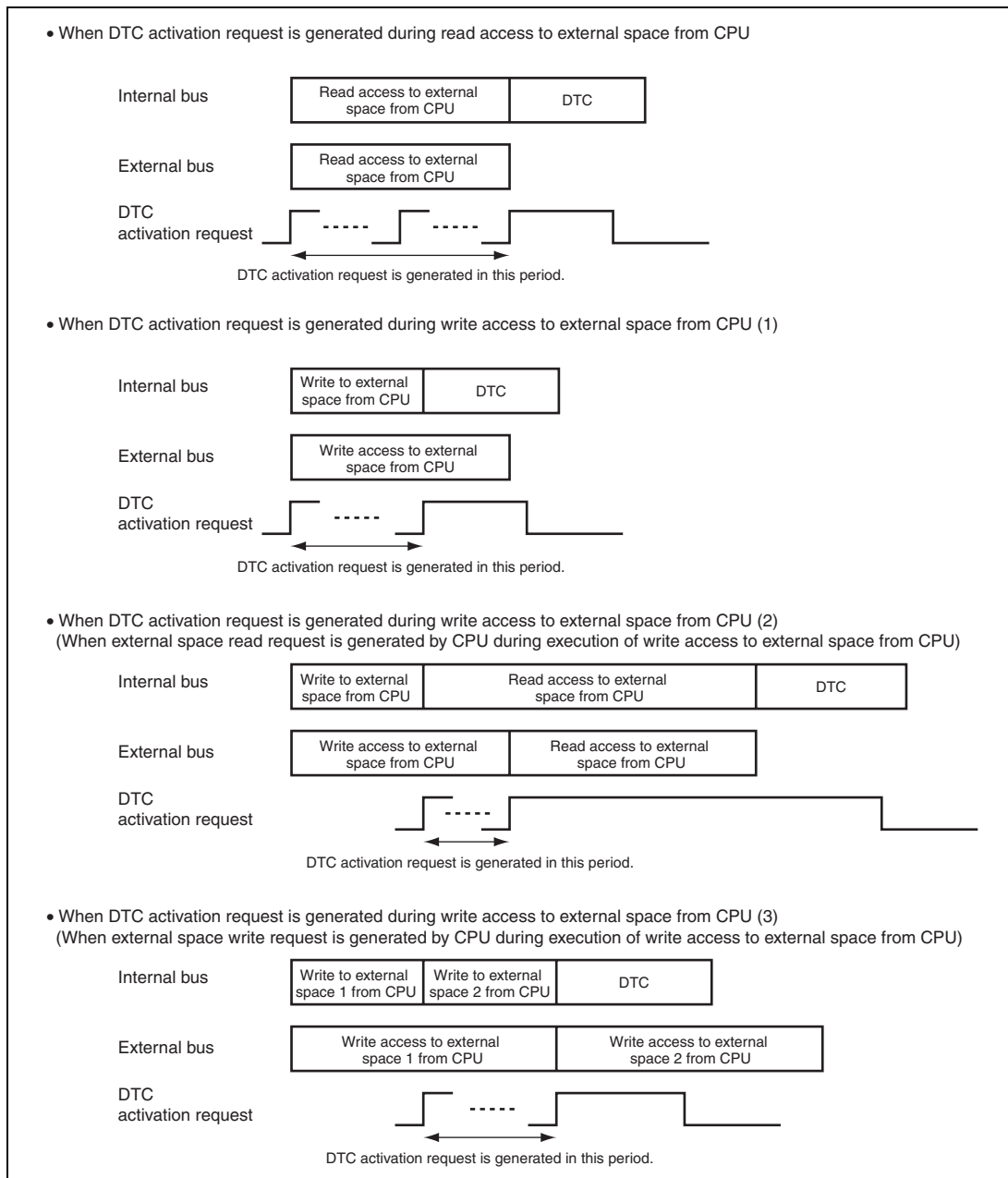

Figure 9.10 Bus Arbitration When DTC Activation Request Occur during External Space Access from CPU

The states that do not allow bus arbitration are shown below.

1. Between the read and write cycles of a TAS instruction
2. Multiple bus cycles generated when the data bus width is smaller than the access size (for example, between bus cycles when longword access is made to a memory with a data bus width of 8 bits)

To prevent device malfunction while the bus mastership is transferred to the external device, the LSI negates all of the bus control signals before bus release. When the bus mastership is received, all of the bus control signals are first negated and then driven appropriately. In addition, to prevent noise while the bus control signal is in the high impedance state, pull-up resistors must be connected to these control signals.

Bus mastership is transferred to the external device at the boundary of bus cycles. Namely, bus mastership is released immediately after receiving a bus request when a bus cycle is not being performed. The release of bus mastership is delayed until the bus cycle is complete when a bus cycle is in progress. Even when from outside the LSI it looks like a bus cycle is not being performed, a bus cycle may be performing internally, started by inserting wait cycles between access cycles. Therefore, it cannot be immediately determined whether or not bus mastership has been released by looking at the \overline{CSn} signal or other bus control signals.

The external bus release by the \overline{BREQ} and \overline{BACK} signal handshaking requires some overhead. If the slave has many tasks, multiple bus cycles should be executed in a bus mastership acquisition. Reducing the cycles required for master to slave bus mastership transitions streamlines the system design.

The LSI has the bus mastership until a bus request is received from the external device. Upon acknowledging the assertion (low level) of the external bus request signal \overline{BREQ} , the LSI releases the bus at the completion of the current bus cycle and asserts the \overline{BACK} signal. After the LSI acknowledges the negation (high level) of the \overline{BREQ} signal that indicates the slave has released the bus, it negates the \overline{BACK} signal and resumes the bus usage.

Processing by this LSI continues even while bus mastership is released to an external device, unless an external device is accessed. When an external device is accessed, the LSI enters the state of waiting for bus mastership to be returned.

While the bus is released, sleep mode, software standby mode, and deep software standby mode cannot be entered.

The bus release sequence is as follows. The address bus and data bus are placed in a high-impedance state synchronized with the rising edge of CK. The bus mastership acknowledge signal is asserted 0.5 cycles after the above high impedance state, synchronized with the falling edge of

CK. The bus control signals such as $\overline{\text{CSn}}$ are placed in the high-impedance state at subsequent rising edges of CK. These bus control signals go high one cycle before being placed in the high-impedance state. Bus request signals are sampled at the falling edge of CK.

The sequence for reclaiming the bus mastership from an external device is described below.

At 1.5 cycles after the negation of $\overline{\text{BREQ}}$ is detected at the falling edge of CK, the bus control signals are driven high. The bus acknowledge signal is negated at the next falling edge of the clock. The fastest timing at which actual bus cycles can be resumed after bus control signal assertion is at the rising edge of the CK where address and data signals are driven. Figure 9.11 shows the bus arbitration timing in master mode.

After $\overline{\text{BREQ}}$ assertion (low level; bus request), the $\overline{\text{BREQ}}$ signal should be negated (high level; bus release) only after the $\overline{\text{BACK}}$ is asserted (low level; bus acknowledge). If $\overline{\text{BREQ}}$ is negated before $\overline{\text{BACK}}$ is asserted, $\overline{\text{BACK}}$ may be asserted only for one cycle depending on the $\overline{\text{BREQ}}$ negation timing, and a bus conflict may occur between the external device and this LSI.

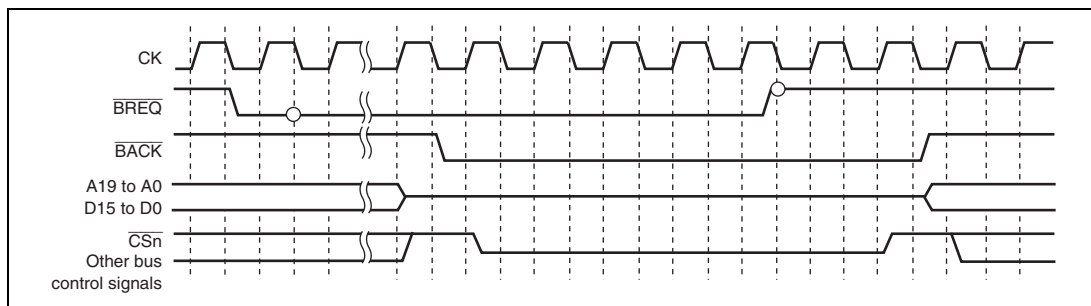

Figure 9.11 Bus Arbitration Timing

Acceptance of mastership for the DTC in bus arbitration does not require the insertion of a NOP, so bus access proceeds continuously.

9.5.7 Others

(1) Reset

The bus state controller (BSC) can be initialized completely only at a power-on reset. At a power-on reset, all signals are negated and output buffers are turned off regardless of the bus cycle state. All control registers are initialized.

In standby, sleep, and manual reset, control registers of the bus state controller are not initialized. At a manual reset, the current bus cycle being executed is completed and then the access wait state is entered. However, a bus arbitration request by the BREQ signal cannot be accepted during manual reset signal assertion.

(2) Access in View of LSI Internal Bus Master

There are three types of LSI internal buses: L bus, I bus, and peripheral bus. The CPU is connected to the L bus. The DTC and bus state controller are connected to the I bus. Low-speed peripheral modules are connected to the peripheral bus. On-chip memories are connected bidirectionally to the L bus and I bus.

For an access of an external space or an on-chip peripheral module, the access is initiated via the I bus. Thus, the DTC can be activated without bus arbitration with the CPU while the CPU is accessing an on-chip memory.

Since the bus state controller (BSC) incorporates a one-stage write buffer, the BSC can execute an access via the I bus before the previous external bus cycle is completed in a write cycle. If the on-chip peripheral module is read or written after the external low-speed memory is written, the on-chip peripheral module can be accessed before the completion of the external low-speed memory write cycle.

In read cycles, the CPU is placed in the wait state until read operation has been completed. To continue the process after the data write to the device has been completed, perform a dummy read to the same address to check for completion of the write before the next process to be executed.

The write buffer of the BSC functions in the same way for an access by the DTC.

Since access cannot be performed correctly if any BSC register values are modified while the write buffer is operating, do not modify BSC registers immediately after a write access. If the BSC register need to be modified immediately after a write access, execute dummy read to confirm the completion of the write access, then modify the BSC register.

9.5.8 Access to On-Chip FLASH and On-Chip RAM by CPU

Access to the on-chip FLASH for read is synchronized with $I\phi$ clock and is executed in one clock cycle. For details on programming and erasing, see section 19, Flash Memory.

Access to the on-chip RAM for read/write is synchronized with $I\phi$ clock and is executed in one clock cycle. For details, see section 21, RAM.

9.5.9 Access to On-Chip Peripheral I/O Registers by CPU

Table 9.10 shows the number of cycles required for access to the on-chip peripheral I/O registers by the CPU.

Table 9.10 Number of Cycles for Access to On-Chip Peripheral I/O Registers

Number of Access Cycles	
Write	$(3 + n) \times I\phi + (1 + m) \times B\phi + 2 \times P\phi$
Read	$(3 + n) \times I\phi + (1 + m) \times B\phi + 2 \times P\phi + 2 \times I\phi$

- Notes: 1. When $I\phi:B\phi = 8:1$, $n = 0$ to 7
 When $I\phi:B\phi = 4:1$, $n = 0$ to 3
 When $B\phi:P\phi = 4:1$, $m = 0$ to 3
 When $I\phi:B\phi = 3:1$, $n = 0$ to 2
 When $B\phi:P\phi = 3:1$, $m = 0$ to 2
 When $I\phi:B\phi = 2:1$, $n = 0$ to 1.
 When $B\phi:P\phi = 2:1$, $m = 0$ to 1.
 When $I\phi:B\phi = 1:1$, $n = 0$.
 When $B\phi:P\phi = 1:1$, $m = 0$
 n and m depend on the internal execution state.
2. The clock ratio of $MI\phi$ and $MP\phi$ does not affect the number of access cycles.

Synchronous logic and a layered bus structure have been adopted for this LSI. Data on each bus are input and output in synchronization with rising edges of the corresponding clock signal. The L bus, I bus, and peripheral bus are synchronized with the $I\phi$, $B\phi$, and $P\phi$ clock, respectively. Figure 9.12 shows an example of the timing of write access to a register in $2P\phi$ cycle access with the connected peripheral bus width of 16 bits when $I\phi:B\phi:P\phi = 4:2:2$. In access to the on-chip peripheral I/O registers, the CPU requires three cycles of $I\phi$ for preparation of data transfer to the I bus after the data has been output to the L bus. After these three cycles, data can be transferred to the I bus in synchronization with rising edges of $B\phi$. However, as there are two $I\phi$ clock cycles in a single $B\phi$ clock cycle when $I\phi: B\phi = 4:2$, transfer of data from the L bus to the I bus takes $(3 +$

$n) \times I\phi$ ($n = 0$ to 1) ($3 \times I\phi$ is indicated in figure 9.52). The relation between the timing of data output to the L bus and the rising edge of $B\phi$ depends on the state of program execution. In the case shown in the figure, where $n = 0$ and $m = 0$, the time required for access is $3 \times I\phi + 1 \times B\phi + 2 \times P\phi$.

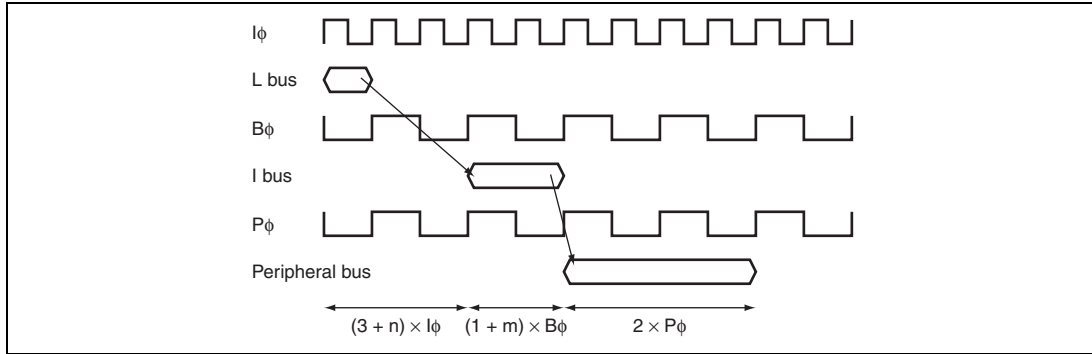

**Figure 9.12 Timing of Write Access to On-Chip Peripheral I/O Registers
When $I\phi:B\phi:P\phi = 4:2:2$**

Figure 9.13 shows an example of timing of read access to the peripheral bus when $I\phi:B\phi:P\phi = 4:2:1$. Transfer from the L bus to the peripheral bus is performed in the same way as for writing. In the case of reading, however, values output onto the peripheral bus need to be transferred to the CPU. Although transfers from the peripheral bus to the I bus and from the I bus to the L bus are performed in synchronization with the rising edge of the respective bus clocks, a period of $2 \times I\phi$ is actually required because $I\phi \geq B\phi \geq P\phi$. In the case shown in the figure, where $n = 0$ and $m = 1$, the time required for access is $3 \times I\phi + 2 \times B\phi + 2 \times P\phi + 2 \times I\phi$.

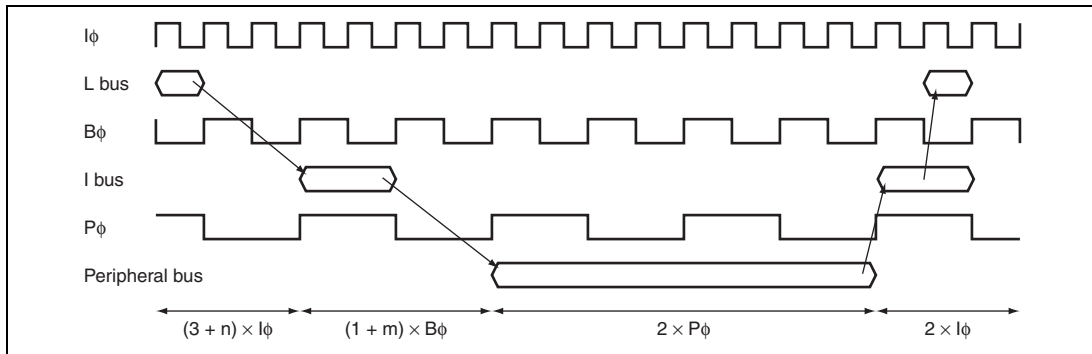

**Figure 9.13 Timing of Read Access to On-Chip Peripheral I/O Registers
When $I\phi:B\phi:P\phi = 4:2:1$**

9.5.10 Access to External Memory by CPU

Table 9.11 shows the number of cycles required for access to the external memory by the CPU. As the table shows, the number of cycles varies with the clock ratio, the access size, the external bus width of the LSI, and the setting for wait insertion. For details on the wait-insertion setting, see section 9.4, Register Descriptions.

Table 9.11 Number of External Access Cycles

External Bus Width	Access Size	Write/Read	Number of Access Cycles
8 bits	Byte	Write	$(1 + n) \times I\phi + (3 + m) \times B\phi$
		Read	$(1 + n) \times I\phi + (3 + m) \times B\phi + 1 \times I\phi$
	Word	Write	$(1 + n) \times I\phi + (3 + m) \times B\phi + 1 \times (2 + o) \times B\phi$
		Read	$(1 + n) \times I\phi + (3 + m) \times B\phi + 1 \times (2 + o) \times B\phi + 1 \times I\phi$
	Longword	Write	$(1 + n) \times I\phi + (3 + m) \times B\phi + 3 \times (2 + o) \times B\phi$
		Read	$(1 + n) \times I\phi + (3 + m) \times B\phi + 3 \times (2 + o) \times B\phi + 1 \times I\phi$
16 bits	Byte/Word	Write	$(1 + n) \times I\phi + (3 + m) \times B\phi$
		Read	$(1 + n) \times I\phi + (3 + m) \times B\phi + 1 \times I\phi$
	Longword	Write	$(1 + n) \times I\phi + (3 + m) \times B\phi + 1 \times (2 + o) \times B\phi$
		Read	$(1 + n) \times I\phi + (3 + m) \times B\phi + 1 \times (2 + o) \times B\phi + 1 \times I\phi$

Note: n: When $I\phi:B\phi = 8:1$, $n = 0$ to 7
 When $I\phi:B\phi = 4:1$, $n = 0$ to 3
 When $I\phi:B\phi = 3:1$, $n = 0$ to 2
 When $I\phi:B\phi = 2:1$, $n = 0$ to 1
 When $I\phi:B\phi = 1:1$, $n = 0$
 m, o: m: Wait setting, o: Wait setting + idle setting
 For details, see section 9.4, Register Descriptions.

Synchronous logic and a layered bus structure have been adopted for this LSI circuit. Data on each bus are input and output in synchronization with rising edges of the corresponding clock signal. The L bus and I bus are synchronized with the $I\phi$ and $B\phi$ clocks, respectively. Figure 9.14 shows an example of the timing of write access to a word of data over the external bus, with a bus-width of 8 bits, when $I\phi:B\phi = 2:1$. Once the CPU has output the data to the L bus, data are transferred to the I bus in synchronization with rising edges of $B\phi$. There are two $I\phi$ clock cycles in a single $B\phi$ clock cycle when $I\phi:B\phi = 2:1$. Thus, when $I\phi:B\phi = 2:1$, data transfer from the L bus to the I bus takes $(1 + n) \times I\phi$ ($n = 0$ to 1) ($2 \times I\phi$ is indicated in figure 9.14). The relation between the timing of data output to the L bus and the rising edge of $B\phi$ depends on the state of program execution. Data output to the I bus are transferred to the external bus after one cycle of $B\phi$. External access to

each data takes at least two cycles, and this can be prolonged by the BSC register settings (m and o in the formulae for number of access cycles). In the case shown in figure 9.14, since $n = 1$, $m = 0$, and $o = 0$, access takes $2 \times I\phi + 3 \times B\phi + 2 \times B\phi$.

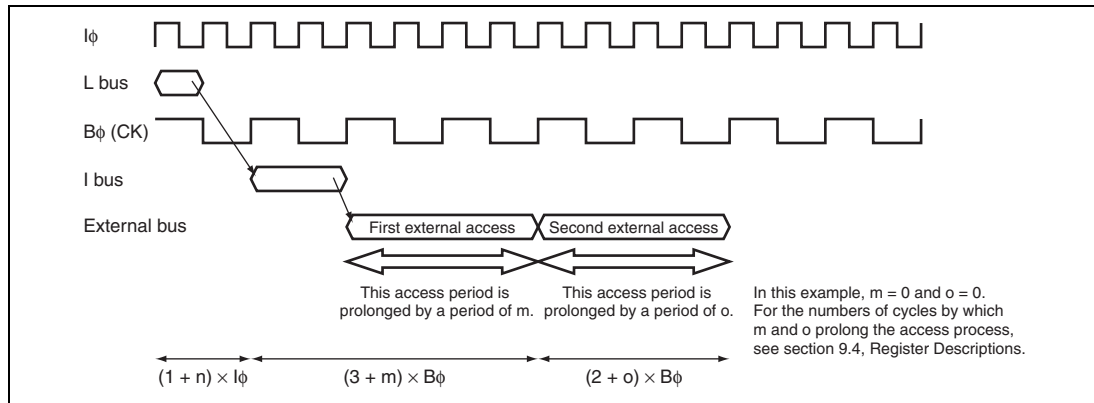

**Figure 9.14 Timing of Write Access to Word Data in External Memory
When $I\phi:B\phi = 2:1$ and External Bus Width is 8 Bits**

Figure 9.15 shows an example of the timing of read access when the external bus width is greater than or equal to the data width and $I\phi:B\phi = 4:1$. Transfer from the L bus to the external bus is performed in the same way as for write access. In the case of reading, however, values output onto the external bus must be transferred to the CPU. Transfers from the external bus to the I bus and from the I bus to the L bus are again performed in synchronization with rising edges of the respective bus clocks. In the actual operation, transfer from the external bus to the L bus takes one ϕ period. In the case shown in the figure, where $n = 2$ and $m = 0$, access takes $3 \times I\phi + 3 \times B\phi + 1 \times I\phi$.

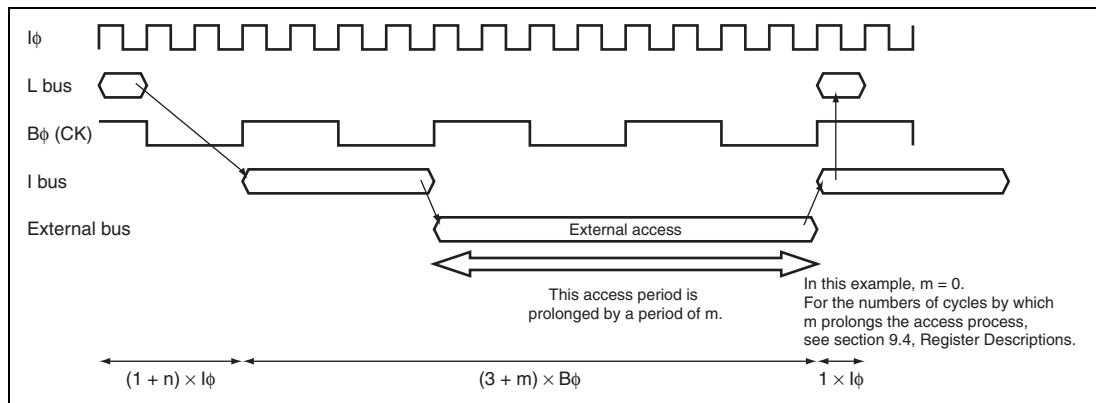

Figure 9.15 Timing of Read Access with Condition $I\phi:B\phi = 4:1$ and External Bus Width \geq Data Width

For access by the DTC, the access cycles are obtained by subtracting the cycles of $I\phi$ required for L-bus access from the access cycles required for access by the CPU.

Section 10 Multi-Function Timer Pulse Unit 2 (MTU2)

This LSI has an on-chip multi-function timer pulse unit 2 (MTU2) that comprises six 16-bit timer channels.

10.1 Features

- Maximum 16 pulse input/output lines and three pulse input lines
- Selection of eight counter input clocks for each channel (four clocks for channel 5)
- The following operations can be set for channels 0 to 4:
 - Waveform output at compare match
 - Input capture function
 - Counter clear operation
 - Multiple timer counters (TCNT) can be written to simultaneously
 - Simultaneous clearing by compare match and input capture is possible
 - Register simultaneous input/output is possible by synchronous counter operation
 - A maximum 12-phase PWM output is possible in combination with synchronous operation
- Buffer operation settable for channels 0, 3, and 4
- Phase counting mode settable independently for each of channels 1 and 2
- Cascade connection operation
- Fast access via internal 16-bit bus
- 28 interrupt sources
- Automatic transfer of register data
- A/D converter start trigger can be generated
- Module standby mode can be settable
- A total of six-phase waveform output, which includes complementary PWM output, and positive and negative phases of reset PWM output by interlocking operation of channels 3 and 4, is possible.
- AC synchronous motor (brushless DC motor) drive mode using complementary PWM output and reset PWM output is settable by interlocking operation of channels 0, 3, and 4, and the selection of two types of waveform outputs (chopping and level) is possible.
- Dead time compensation counter available in channel 5
- In complementary PWM mode, interrupts at the crest and trough of the counter value and A/D converter start triggers can be skipped.

Table 10.1 MTU2 Functions

Item	Channel 0	Channel 1	Channel 2	Channel 3	Channel 4	Channel 5
Count clock	MP ϕ /1	MP ϕ /1	MP ϕ /1	MP ϕ /1	MP ϕ /1	MP ϕ /1
	MP ϕ /4	MP ϕ /4	MP ϕ /4	MP ϕ /4	MP ϕ /4	MP ϕ /4
	MP ϕ /16	MP ϕ /16	MP ϕ /16	MP ϕ /16	MP ϕ /16	MP ϕ /16
	MP ϕ /64	MP ϕ /64	MP ϕ /64	MP ϕ /64	MP ϕ /64	MP ϕ /64
	TCLKA	MP ϕ /256	MP ϕ /1024	MP ϕ /256	MP ϕ /256	
	TCLKB	TCLKA	TCLKA	MP ϕ /1024	MP ϕ /1024	
	TCLKC	TCLKB	TCLKB	TCLKA	TCLKA	
	TCLKD		TCLKC	TCLKB	TCLKB	
General registers	TGRA_0	TGRA_1	TGRA_2	TGRA_3	TGRA_4	TGRU_5
	TGRB_0	TGRB_1	TGRB_2	TGRB_3	TGRB_4	TGRV_5
	TGRE_0					TGRW_5
General registers/ buffer registers	TGRC_0	—	—	TGRC_3	TGRC_4	—
	TGRD_0			TGRD_3	TGRD_4	
	TGRF_0					
I/O pins	TIOC0A	TIOC1A	TIOC2A	TIOC3A	TIOC4A	Input pins
	TIOC0B	TIOC1B	TIOC2B	TIOC3B	TIOC4B	TIC5U
	TIOC0C			TIOC3C	TIOC4C	TIC5V
	TIOC0D			TIOC3D	TIOC4D	TIC5W
Counter clear function	TGR	TGR	TGR	TGR	TGR	TGR
	compare match or input capture	compare match or input capture	compare match or input capture	compare match or input capture	compare match or input capture	compare match or input capture
Compare match output	0 output	√	√	√	√	—
	1 output	√	√	√	√	—
	Toggle output	√	√	√	√	—
Input capture function	√	√	√	√	√	√
Synchronous operation	√	√	√	√	√	—
PWM mode 1	√	√	√	√	√	—
PWM mode 2	√	√	√	—	—	—
Complementary PWM mode	—	—	—	√	√	—
Reset PWM mode	—	—	—	√	√	—
AC synchronous motor drive mode	√	—	—	√	√	—

Item	Channel 0	Channel 1	Channel 2	Channel 3	Channel 4	Channel 5
Phase counting mode	—	√	√	—	—	—
Buffer operation	√	—	—	√	√	—
Dead time compensation counter function	—	—	—	—	—	√
DTC activation	TGR compare match or input capture	TGR compare match or input capture	TGR compare match or input capture	TGR compare match or input capture	TGR compare match or input capture and TCNT overflow or underflow	TGR compare match or input capture
A/D converter start trigger	TGRA_0 compare match or input capture	TGRA_1 compare match or input capture	TGRA_2 compare match or input capture	TGRA_3 compare match or input capture	TGRA_4 compare match or input capture	—
	TGRE_0 compare match				TCNT_4 underflow (trough) in complementary PWM mode	

Item	Channel 0	Channel 1	Channel 2	Channel 3	Channel 4	Channel 5
Interrupt sources	7 sources	4 sources	4 sources	5 sources	5 sources	3 sources
	<ul style="list-style-type: none"> Compare match or input capture 0A Compare match or input capture 0B Compare match or input capture 0C Compare match or input capture 0D Compare match 0E Compare match 0F Overflow 	<ul style="list-style-type: none"> Compare match or input capture 1A Compare match or input capture 1B Overflow Underflow 	<ul style="list-style-type: none"> Compare match or input capture 2A Compare match or input capture 2B Overflow Underflow 	<ul style="list-style-type: none"> Compare match or input capture 3A Compare match or input capture 3B Compare match or input capture 3C Compare match or input capture 3D Overflow 	<ul style="list-style-type: none"> Compare match or input capture 4A Compare match or input capture 4B Compare match or input capture 4C Compare match or input capture 4D Overflow or underflow 	<ul style="list-style-type: none"> Compare match or input capture 5U Compare match or input capture 5V Compare match or input capture 5W

Item	Channel 0	Channel 1	Channel 2	Channel 3	Channel 4	Channel 5
A/D converter start request delaying function	—	—	—	—	<ul style="list-style-type: none"> • A/D converter start request at a match between TADCOR A_4 and TCNT_4 • A/D converter start request at a match between TADCOR B_4 and TCNT_4 	—
Interrupt skipping function	—	—	—	<ul style="list-style-type: none"> • Skips TGRA_3 compare match interrupts 	<ul style="list-style-type: none"> • Skips TCIV_4 interrupts 	—

[Legend]

√: Possible

—: Not possible

Figure 10.1 shows a block diagram of the MTU2.

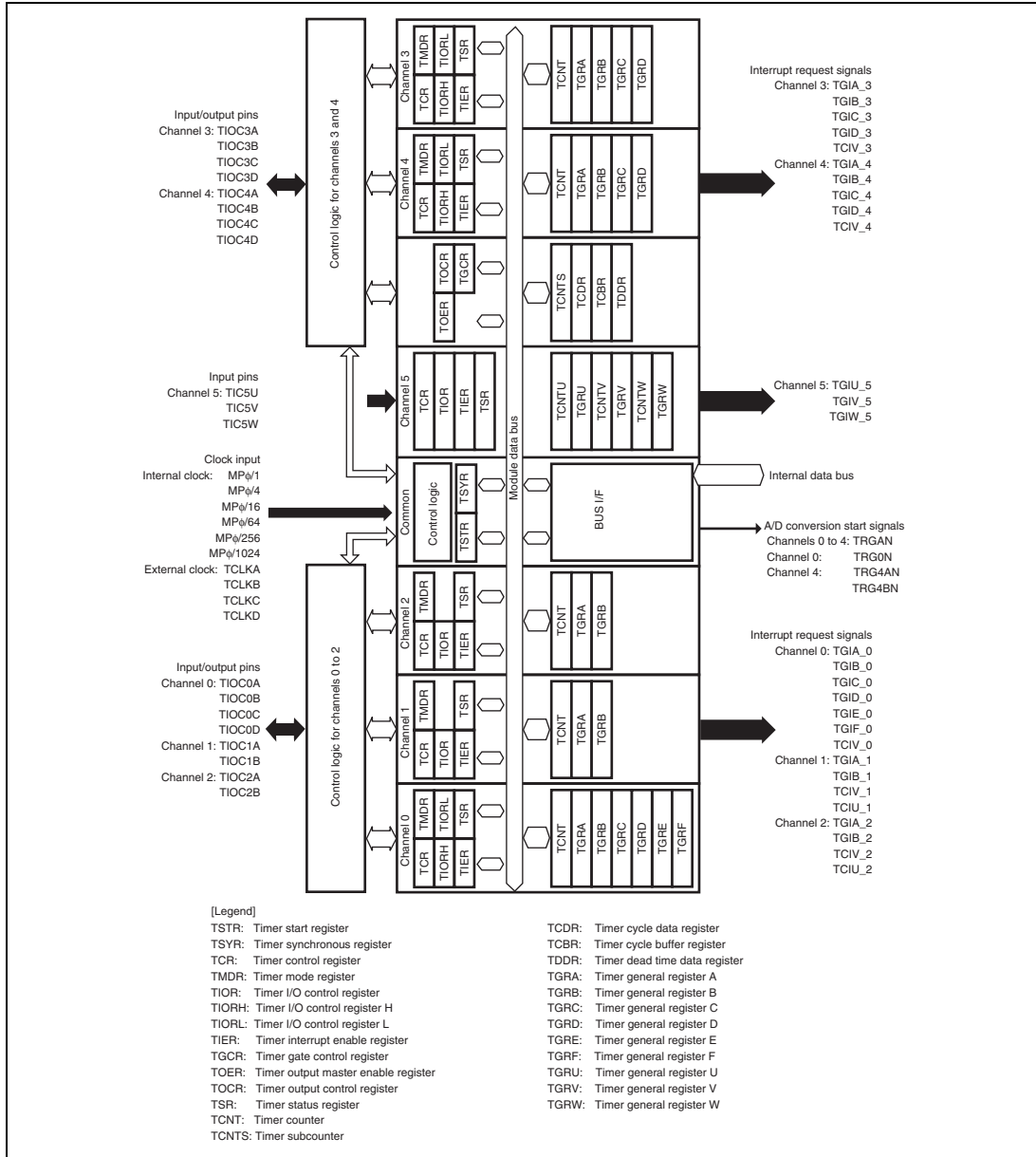

Figure 10.1 Block Diagram of MTU2

10.2 Input/Output Pins

Table 10.2 Pin Configuration

Channel	Pin Name	I/O	Function
Common	TCLKA	Input	External clock A input pin (Channel 1 phase counting mode A phase input)
	TCLKB	Input	External clock B input pin (Channel 1 phase counting mode B phase input)
	TCLKC	Input	External clock C input pin (Channel 2 phase counting mode A phase input)
	TCLKD	Input	External clock D input pin (Channel 2 phase counting mode B phase input)
0	TIOC0A	I/O	TGRA_0 input capture input/output compare output/PWM output pin
	TIOC0B	I/O	TGRB_0 input capture input/output compare output/PWM output pin
	TIOC0C	I/O	TGRC_0 input capture input/output compare output/PWM output pin
	TIOC0D	I/O	TGRD_0 input capture input/output compare output/PWM output pin
1	TIOC1A	I/O	TGRA_1 input capture input/output compare output/PWM output pin
	TIOC1B	I/O	TGRB_1 input capture input/output compare output/PWM output pin
2	TIOC2A	I/O	TGRA_2 input capture input/output compare output/PWM output pin
	TIOC2B	I/O	TGRB_2 input capture input/output compare output/PWM output pin
3	TIOC3A	I/O	TGRA_3 input capture input/output compare output/PWM output pin
	TIOC3B	I/O	TGRB_3 input capture input/output compare output/PWM output pin
	TIOC3C	I/O	TGRC_3 input capture input/output compare output/PWM output pin
	TIOC3D	I/O	TGRD_3 input capture input/output compare output/PWM output pin
4	TIOC4A	I/O	TGRA_4 input capture input/output compare output/PWM output pin
	TIOC4B	I/O	TGRB_4 input capture input/output compare output/PWM output pin
	TIOC4C	I/O	TGRC_4 input capture input/output compare output/PWM output pin
	TIOC4D	I/O	TGRD_4 input capture input/output compare output/PWM output pin
5	TIC5U	Input	TGRU_5 input capture input/external pulse input pin
	TIC5V	Input	TGRV_5 input capture input/external pulse input pin
	TIC5W	Input	TGRW_5 input capture input/external pulse input pin

10.3 Register Descriptions

The MTU2 has the following registers. For details on register addresses and register states during each process, refer to section 23, List of Registers. To distinguish registers in each channel, an underscore and the channel number are added as a suffix to the register name; TCR for channel 0 is expressed as TCR_0.

Table 10.3 Register Configuration

Register Name	Abbreviation	R/W	Initial value	Address	Access Size
Timer control register_3	TCR_3	R/W	H'00	H'FFFC200	8, 16, 32
Timer control register_4	TCR_4	R/W	H'00	H'FFFC201	8
Timer mode register_3	TMDR_3	R/W	H'00	H'FFFC202	8, 16
Timer mode register_4	TMDR_4	R/W	H'00	H'FFFC203	8
Timer I/O control register H_3	TIORH_3	R/W	H'00	H'FFFC204	8, 16, 32
Timer I/O control register L_3	TIORL_3	R/W	H'00	H'FFFC205	8
Timer I/O control register H_4	TIORH_4	R/W	H'00	H'FFFC206	8, 16
Timer I/O control register L_4	TIORL_4	R/W	H'00	H'FFFC207	8
Timer interrupt enable register_3	TIER_3	R/W	H'00	H'FFFC208	8, 16
Timer interrupt enable register_4	TIER_4	R/W	H'00	H'FFFC209	8
Timer output master enable register	TOER	R/W	H'C0	H'FFFC20A	8
Timer gate control register	TGCR	R/W	H'80	H'FFFC20D	8
Timer output control register 1	TOCR1	R/W	H'00	H'FFFC20E	8, 16
Timer output control register 2	TOCR2	R/W	H'00	H'FFFC20F	8
Timer counter_3	TCNT_3	R/W	H'0000	H'FFFC210	16, 32
Timer counter_4	TCNT_4	R/W	H'0000	H'FFFC212	16
Timer cycle data register	TCDR	R/W	H'FFFF	H'FFFC214	16, 32
Timer dead time data register	TDDR	R/W	H'FFFF	H'FFFC216	16
Timer general register A_3	TGRA_3	R/W	H'FFFF	H'FFFC218	16, 32
Timer general register B_3	TGRB_3	R/W	H'FFFF	H'FFFC21A	16
Timer general register A_4	TGRA_4	R/W	H'FFFF	H'FFFC21C	16, 32
Timer general register B_4	TGRB_4	R/W	H'FFFF	H'FFFC21E	16

Register Name	Abbreviation	R/W	Initial value	Address	Access Size
Timer subcounter	TCNTS	R	H'0000	H'FFFFC220	16, 32
Timer cycle buffer register	TCBR	R/W	H'FFFF	H'FFFFC222	16
Timer general register C_3	TGRC_3	R/W	H'FFFF	H'FFFFC224	16, 32
Timer general register D_3	TGRD_3	R/W	H'FFFF	H'FFFFC226	16
Timer general register C_4	TGRC_4	R/W	H'FFFF	H'FFFFC228	16, 32
Timer general register D_4	TGRD_4	R/W	H'FFFF	H'FFFFC22A	16
Timer status register_3	TSR_3	R/W	H'C0	H'FFFFC22C	8, 16
Timer status register_4	TSR_4	R/W	H'C0	H'FFFFC22D	8
Timer interrupt skipping set register	TITCR	R/W	H'00	H'FFFFC230	8, 16
Timer interrupt skipping counter	TITCNT	R	H'00	H'FFFFC231	8
Timer buffer transfer set register	TBTER	R/W	H'00	H'FFFFC232	8
Timer dead time enable register	TDER	R/W	H'01	H'FFFFC234	8
Timer output level buffer register	TOLBR	R/W	H'00	H'FFFFC236	8
Timer buffer operation transfer mode register_3	TBTM_3	R/W	H'00	H'FFFFC238	8, 16
Timer buffer operation transfer mode register_4	TBTM_4	R/W	H'00	H'FFFFC239	8
Timer A/D converter start request control register	TADCR	R/W	H'0000	H'FFFFC240	16
Timer A/D converter start request cycle set register A_4	TADCORA_4	R/W	H'FFFF	H'FFFFC244	16, 32
Timer A/D converter start request cycle set register B_4	TADCORB_4	R/W	H'FFFF	H'FFFFC246	16
Timer A/D converter start request cycle set buffer register A_4	TADCOBRA_4	R/W	H'FFFF	H'FFFFC248	16, 32
Timer A/D converter start request cycle set buffer register B_4	TADCOBRB_4	R/W	H'FFFF	H'FFFFC24A	16

Register Name	Abbreviation	R/W	Initial value	Address	Access Size
Timer waveform control register	TWCR	R/W	H'00	H'FFFC260	8
Timer start register	TSTR	R/W	H'00	H'FFFC280	8, 16
Timer synchronous register	TSYR	R/W	H'00	H'FFFC281	8
Timer counter synchronous start register	TCSYSTR	R/W	H'00	H'FFFC282	8
Timer read/write enable register	TRWER	R/W	H'01	H'FFFC284	8
Timer control register_0	TCR_0	R/W	H'00	H'FFFC300	8, 16, 32
Timer mode register_0	TMDR_0	R/W	H'00	H'FFFC301	8
Timer I/O control register H_0	TIORH_0	R/W	H'00	H'FFFC302	8, 16
Timer I/O control register L_0	TIORL_0	R/W	H'00	H'FFFC303	8
Timer interrupt enable register_0	TIER_0	R/W	H'00	H'FFFC304	8, 16, 32
Timer status register_0	TSR_0	R/W	H'C0	H'FFFC305	8
Timer counter_0	TCNT_0	R/W	H'0000	H'FFFC306	16
Timer general register A_0	TGRA_0	R/W	H'FFFF	H'FFFC308	16, 32
Timer general register B_0	TGRB_0	R/W	H'FFFF	H'FFFC30A	16
Timer general register C_0	TGRC_0	R/W	H'FFFF	H'FFFC30C	16, 32
Timer general register D_0	TGRD_0	R/W	H'FFFF	H'FFFC30E	16
Timer general register E_0	TGRE_0	R/W	H'FFFF	H'FFFC320	16, 32
Timer general register F_0	TGRF_0	R/W	H'FFFF	H'FFFC322	16
Timer interrupt enable register 2_0	TIER2_0	R/W	H'00	H'FFFC324	8, 16
Timer status register 2_0	TSR2_0	R/W	H'C0	H'FFFC325	8
Timer buffer operation transfer mode register_0	TBTM_0	R/W	H'00	H'FFFC326	8
Timer control register_1	TCR_1	R/W	H'00	H'FFFC380	8, 16
Timer mode register_1	TMDR_1	R/W	H'00	H'FFFC381	8
Timer I/O control register_1	TIOR_1	R/W	H'00	H'FFFC382	8
Timer interrupt enable register_1	TIER_1	R/W	H'00	H'FFFC384	8, 16, 32
Timer status register_1	TSR_1	R/W	H'C0	H'FFFC385	8

Register Name	Abbrevia- tion	R/W	Initial value	Address	Access Size
Timer counter_1	TCNT_1	R/W	H'0000	H'FFFFC386	16
Timer general register A_1	TGRA_1	R/W	H'FFFF	H'FFFFC388	16, 32
Timer general register B_1	TGRB_1	R/W	H'FFFF	H'FFFFC38A	16
Timer input capture control register	TICCR	R/W	H'00	H'FFFFC390	8
Timer control register_2	TCR_2	R/W	H'00	H'FFFFC400	8, 16
Timer mode register_2	TMDR_2	R/W	H'00	H'FFFFC401	8
Timer I/O control register_2	TIOR_2	R/W	H'00	H'FFFFC402	8
Timer interrupt enable register_2	TIER_2	R/W	H'00	H'FFFFC404	8, 16, 32
Timer status register_2	TSR_2	R/W	H'C0	H'FFFFC405	8
Timer counter_2	TCNT_2	R/W	H'0000	H'FFFFC406	16
Timer general register A_2	TGRA_2	R/W	H'FFFF	H'FFFFC408	16, 32
Timer general register B_2	TGRB_2	R/W	H'FFFF	H'FFFFC40A	16
Timer counter U_5	TCNTU_5	R/W	H'0000	H'FFFFC480	16, 32
Timer general register U_5	TGRU_5	R/W	H'FFFF	H'FFFFC482	16
Timer control register U_5	TCRU_5	R/W	H'00	H'FFFFC484	8
Timer I/O control register U_5	TIORU_5	R/W	H'00	H'FFFFC486	8
Timer counter V_5	TCNTV_5	R/W	H'0000	H'FFFFC490	16, 32
Timer general register V_5	TGRV_5	R/W	H'FFFF	H'FFFFC492	16
Timer control register V_5	TCRV_5	R/W	H'00	H'FFFFC494	8
Timer I/O control register V_5	TIORV_5	R/W	H'00	H'FFFFC496	8
Timer counter W_5	TCNTW_5	R/W	H'0000	H'FFFFC4A0	16, 32
Timer general register W_5	TGRW_5	R/W	H'FFFF	H'FFFFC4A2	16
Timer control register W_5	TCRW_5	R/W	H'00	H'FFFFC4A4	8
Timer I/O control register W_5	TIORW_5	R/W	H'00	H'FFFFC4A6	8
Timer status register_5	TSR_5	R/W	H'00	H'FFFFC4B0	8
Timer interrupt enable register_5	TIER_5	R/W	H'00	H'FFFFC4B2	8
Timer start register_5	TSTR_5	R/W	H'00	H'FFFFC4B4	8
Timer compare match clear register	TCNTCMPCLR	R/W	H'00	H'FFFFC4B6	8

10.3.1 Timer Control Register (TCR)

The TCR registers are 8-bit readable/writable registers that control the TCNT operation for each channel. The MTU2 has a total of eight TCR registers, one each for channels 0 to 4 and three (TCRU_5, TCRV_5, and TCRW_5) for channel 5. TCR register settings should be conducted only when TCNT operation is stopped.

Bit:	7	6	5	4	3	2	1	0
	CCLR[2:0]			CKEG[1:0]		TPSC[2:0]		
Initial value:	0	0	0	0	0	0	0	0
R/W:	R/W	R/W	R/W	R/W	R/W	R/W	R/W	R/W

Bit	Bit Name	Initial Value	R/W	Description
7 to 5	CCLR[2:0]	000	R/W	Counter Clear 0 to 2 These bits select the TCNT counter clearing source. See tables 10.4 and 10.5 for details.
4, 3	CKEG[1:0]	00	R/W	Clock Edge 0 and 1 These bits select the input clock edge. When the input clock is counted using both edges, the input clock period is halved (e.g. $MP\phi/4$ both edges = $MP\phi/2$ rising edge). If phase counting mode is used on channels 1 and 2, this setting is ignored and the phase counting mode setting has priority. Internal clock edge selection is valid when the input clock is $MP\phi/4$ or slower. When $MP\phi/1$, or the overflow/underflow of another channel is selected for the input clock, although values can be written, counter operation compiles with the initial value. 00: Count at rising edge 01: Count at falling edge 1x: Count at both edges
2 to 0	TPSC[2:0]	000	R/W	Time Prescaler 0 to 2 These bits select the TCNT counter clock. The clock source can be selected independently for each channel. See tables 10.6 to 10.10 for details.

[Legend]

x: Don't care

Table 10.4 CCLR0 to CCLR2 (Channels 0, 3, and 4)

Channel	Bit 7 CCLR2	Bit 6 CCLR1	Bit 5 CCLR0	Description
0, 3, 4	0	0	0	TCNT clearing disabled
			1	TCNT cleared by TGRA compare match/input capture
			0	TCNT cleared by TGRB compare match/input capture
	1	0	1	TCNT cleared by counter clearing for another channel performing synchronous clearing/ synchronous operation* ¹
			0	TCNT clearing disabled
			1	TCNT cleared by TGRC compare match/input capture* ²
1	1	0	TCNT cleared by TGRD compare match/input capture* ²	
		1	TCNT cleared by counter clearing for another channel performing synchronous clearing/ synchronous operation* ¹	

Notes: 1. Synchronous operation is set by setting the SYNC bit in TSYR to 1.
 2. When TGRC or TGRD is used as a buffer register, TCNT is not cleared because the buffer register setting has priority, and compare match/input capture does not occur.

Table 10.5 CCLR0 to CCLR2 (Channels 1 and 2)

Channel	Bit 7 Reserved* ²	Bit 6 CCLR1	Bit 5 CCLR0	Description
1, 2	0	0	0	TCNT clearing disabled
			1	TCNT cleared by TGRA compare match/input capture
			0	TCNT cleared by TGRB compare match/input capture
	1	1	1	TCNT cleared by counter clearing for another channel performing synchronous clearing/ synchronous operation* ¹

Notes: 1. Synchronous operation is selected by setting the SYNC bit in TSYR to 1.
 2. Bit 7 is reserved in channels 1 and 2. It is always read as 0 and cannot be modified.

Table 10.6 TPSC0 to TPSC2 (Channel 0)

Channel	Bit 2 TPSC2	Bit 1 TPSC1	Bit 0 TPSC0	Description
0	0	0	0	Internal clock: counts on MP ϕ /1
			1	Internal clock: counts on MP ϕ /4
		1	0	Internal clock: counts on MP ϕ /16
			1	Internal clock: counts on MP ϕ /64
	1	0	0	External clock: counts on TCLKA pin input
			1	External clock: counts on TCLKB pin input
		1	0	External clock: counts on TCLKC pin input
			1	External clock: counts on TCLKD pin input

Table 10.7 TPSC0 to TPSC2 (Channel 1)

Channel	Bit 2 TPSC2	Bit 1 TPSC1	Bit 0 TPSC0	Description
1	0	0	0	Internal clock: counts on MP ϕ /1
			1	Internal clock: counts on MP ϕ /4
		1	0	Internal clock: counts on MP ϕ /16
			1	Internal clock: counts on MP ϕ /64
	1	0	0	External clock: counts on TCLKA pin input
			1	External clock: counts on TCLKB pin input
		1	0	Internal clock: counts on MP ϕ /256
			1	Counts on TCNT_2 overflow/underflow

Note: This setting is ignored when channel 1 is in phase counting mode.

Table 10.8 TPSC0 to TPSC2 (Channel 2)

Channel	Bit 2 TPSC2	Bit 1 TPSC1	Bit 0 TPSC0	Description
2	0	0	0	Internal clock: counts on MP ϕ /1
			1	Internal clock: counts on MP ϕ /4
		1	0	Internal clock: counts on MP ϕ /16
			1	Internal clock: counts on MP ϕ /64
	1	0	0	External clock: counts on TCLKA pin input
			1	External clock: counts on TCLKB pin input
		1	0	External clock: counts on TCLKC pin input
			1	Internal clock: counts on MP ϕ /1024

Note: This setting is ignored when channel 2 is in phase counting mode.

Table 10.9 TPSC0 to TPSC2 (Channels 3 and 4)

Channel	Bit 2 TPSC2	Bit 1 TPSC1	Bit 0 TPSC0	Description
3, 4	0	0	0	Internal clock: counts on MP ϕ /1
			1	Internal clock: counts on MP ϕ /4
		1	0	Internal clock: counts on MP ϕ /16
			1	Internal clock: counts on MP ϕ /64
	1	0	0	Internal clock: counts on MP ϕ /256
			1	Internal clock: counts on MP ϕ /1024
		1	0	External clock: counts on TCLKA pin input
			1	External clock: counts on TCLKB pin input

Table 10.10 TPSC1 and TPSC0 (Channel 5)

Channel	Bit 1 TPSC1	Bit 0 TPSC0	Description
5	0	0	Internal clock: counts on MP ϕ /1
		1	Internal clock: counts on MP ϕ /4
	1	0	Internal clock: counts on MP ϕ /16
		1	Internal clock: counts on MP ϕ /64

Note: Bits 7 to 2 are reserved in channel 5. These bits are always read as 0. The write value should always be 0.

10.3.2 Timer Mode Register (TMDR)

The TMDR registers are 8-bit readable/writable registers that are used to set the operating mode of each channel. The MTU2 has five TMDR registers, one each for channels 0 to 4. TMDR register settings should be changed only when TCNT operation is stopped.

Bit:	7	6	5	4	3	2	1	0
	-	BFE	BFB	BFA	MD[3:0]			
Initial value:	0	0	0	0	0	0	0	0
R/W:	-	R/W	R/W	R/W	R/W	R/W	R/W	R/W

Bit	Bit Name	Initial Value	R/W	Description
7	—	0	—	Reserved This bit is always read as 0. The write value should always be 0.
6	BFE	0	R/W	Buffer Operation E Specifies whether TGRE_0 and TGRF_0 are to operate in the normal way or to be used together for buffer operation. Compare match with TGRF occurs even when TGRF is used as a buffer register. In channels 1 to 4, this bit is reserved. It is always read as 0 and the write value should always be 0. 0: TGRE_0 and TGRF_0 operate normally 1: TGRE_0 and TGRF_0 used together for buffer operation

Bit	Bit Name	Initial Value	R/W	Description
5	BFB	0	R/W	<p>Buffer Operation B</p> <p>Specifies whether TGRB is to operate in the normal way, or TGRB and TGRD are to be used together for buffer operation. When TGRD is used as a buffer register, TGRD input capture/output compare do not take place in modes other than complementary PWM mode, but compare match with TGRD occurs in complementary PWM mode. Since the TGFD flag will be set if a compare match occurs during Tb interval in complementary PWM mode, the TGIED bit in timer interrupt enable register 3/4 (TIER_3/4) should be cleared to 0.</p> <p>In channels 1 and 2, which have no TGRD, bit 5 is reserved. It is always read as 0 and cannot be modified.</p> <p>0: TGRB and TGRD operate normally 1: TGRB and TGRD used together for buffer operation</p>
4	BFA	0	R/W	<p>Buffer Operation A</p> <p>Specifies whether TGRA is to operate in the normal way, or TGRA and TGRC are to be used together for buffer operation. When TGRC is used as a buffer register, TGRC input capture/output compare do not take place in modes other than complementary PWM mode, but compare match with TGRC occurs in complementary PWM mode. Since the TGFC flag will be set if a compare match occurs on channel 4 during Tb interval in complementary PWM mode, the TGIEC bit in timer interrupt enable register 4 (TIER_4) should be cleared to 0.</p> <p>In channels 1 and 2, which have no TGRC, bit 4 is reserved. It is always read as 0 and cannot be modified.</p> <p>0: TGRA and TGRC operate normally 1: TGRA and TGRC used together for buffer operation</p>
3 to 0	MD[3:0]	0000	R/W	<p>Modes 0 to 3</p> <p>These bits are used to set the timer operating mode. See table 10.11 for details.</p>

Table 10.11 Setting of Operation Mode by Bits MD0 to MD3

Bit 3 MD3	Bit 2 MD2	Bit 1 MD1	Bit 0 MD0	Description	
0	0	0	0	Normal operation	
			1	Setting prohibited	
	1	0	1	0	PWM mode 1
				1	PWM mode 2* ¹
			0	0	Phase counting mode 1* ²
				1	Phase counting mode 2* ²
		1	0	Phase counting mode 3* ²	
			1	Phase counting mode 4* ²	
1	0	0	0	Reset synchronous PWM mode* ³	
			1	Setting prohibited	
		1	x	Setting prohibited	
			0	Setting prohibited	
	1	0	1	0	Complementary PWM mode 1 (transmit at crest)* ³
				1	Complementary PWM mode 2 (transmit at trough)* ³
			1	0	Complementary PWM mode 2 (transmit at trough)* ³
				1	Complementary PWM mode 2 (transmit at crest and trough)* ³

[Legend]

x: Don't care

- Notes:
1. PWM mode 2 cannot be set for channels 3 and 4.
 2. Phase counting mode cannot be set for channels 0, 3, and 4.
 3. Reset synchronous PWM mode and complementary PWM mode can only be set for channel 3. When channel 3 is set to reset synchronous PWM mode or complementary PWM mode, the channel 4 settings become ineffective and automatically conform to the channel 3 settings. However, do not set channel 4 to reset synchronous PWM mode or complementary PWM mode. Reset synchronous PWM mode and complementary PWM mode cannot be set for channels 0, 1, and 2.

10.3.3 Timer I/O Control Register (TIOR)

The TIOR registers are 8-bit readable/writable registers that control the TGR registers. The MTU2 has a total of eleven TIOR registers, two each for channels 0, 3, and 4, one each for channels 1 and 2, and three (TIORU_5, TIORV_5, and TIORW_5) for channel 5.

TIOR should be set when TMDR is set to select normal operation, PWM mode, or phase counting mode. The initial output specified by TIOR is valid when the counter is stopped (the CST bit in TSTR is cleared to 0). Note also that, in PWM mode 2, the output at the point at which the counter is cleared to 0 is specified.

When TGRC or TGRD is designated for buffer operation, this setting is invalid and the register operates as a buffer register.

- TIORH_0, TIOR_1, TIOR_2, TIORH_3, TIORH_4

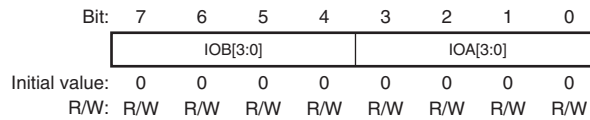

Bit	Bit Name	Initial Value	R/W	Description
7 to 4	IOB[3:0]	0000	R/W	I/O Control B0 to B3 Specify the function of TGRB. See the following tables. TIORH_0: Table 10.12 TIOR_1: Table 10.14 TIOR_2: Table 10.15 TIORH_3: Table 10.16 TIORH_4: Table 10.18
3 to 0	IOA[3:0]	0000	R/W	I/O Control A0 to A3 Specify the function of TGRA. See the following tables. TIORH_0: Table 10.20 TIOR_1: Table 10.22 TIOR_2: Table 10.23 TIORH_3: Table 10.24 TIORH_4: Table 10.26

- TIORL_0, TIORL_3, TIORL_4

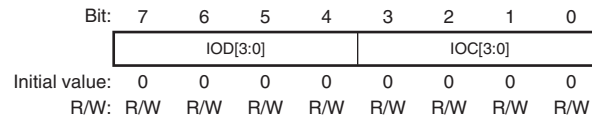

Bit	Bit Name	Initial Value	R/W	Description
7 to 4	IOD[3:0]	0000	R/W	I/O Control D0 to D3 Specify the function of TGRD. See the following tables. TIORL_0: Table 10.13 TIORL_3: Table 10.17 TIORL_4: Table 10.19
3 to 0	IOC[3:0]	0000	R/W	I/O Control C0 to C3 Specify the function of TGRC. See the following tables. TIORL_0: Table 10.21 TIORL_3: Table 10.25 TIORL_4: Table 10.27

- TIORU_5, TIORV_5, TIORW_5

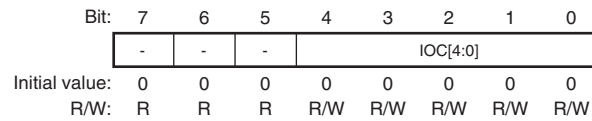

Bit	Bit Name	Initial Value	R/W	Description
7 to 5	—	All 0	R	Reserved These bits are always read as 0. The write value should always be 0.
4 to 0	IOC[4:0]	00000	R/W	I/O Control C0 to C4 Specify the function of TGRU_5, TGRV_5, and TGRW_5. For details, see table 10.28.

Table 10.12 TIORH_0 (Channel 0)

				Description			
Bit 7 IOB3	Bit 6 IOB2	Bit 5 IOB1	Bit 4 IOB0	TGRB_0 Function	TIOC0B Pin Function		
0	0	0	0	Output compare register	Output retained*		
			1		Initial output is 0 0 output at compare match		
		1	0		Initial output is 0 1 output at compare match		
			1		Initial output is 0 Toggle output at compare match		
	1	0	0		0	Output retained	
					1	Initial output is 1 0 output at compare match	
			1		0	Initial output is 1 1 output at compare match	
					1	Initial output is 1 Toggle output at compare match	
		1	x		x	0	Input capture at rising edge
						1	Input capture at falling edge
			1		x	x	Input capture at both edges
						x	Capture input source is channel 1/count clock Input capture at TCNT_1 count-up/count-down

[Legend]

x: Don't care

Note: * After power-on reset, 0 is output until TIOR is set.

Table 10.13 TIORL_0 (Channel 0)

				Description				
Bit 7 IOD3	Bit 6 IOD2	Bit 5 IOD1	Bit 4 IOD0	TGRD_0 Function	TIOC0D Pin Function			
0	0	0	0	Output compare register*2	Output retained*1			
			1		Initial output is 0 0 output at compare match			
			0		Initial output is 0 1 output at compare match			
			1		Initial output is 0 Toggle output at compare match			
			1		0	0	Output retained	
						1	Initial output is 1 0 output at compare match	
						0	Initial output is 1 1 output at compare match	
						1	Initial output is 1 Toggle output at compare match	
			1		0	0	Input capture register*2	Input capture at rising edge
						1	Input capture at falling edge	
						1	x	Input capture at both edges
						1	x	Capture input source is channel 1/count clock Input capture at TCNT_1 count-up/count-down

[Legend]

x: Don't care

Notes: 1. After power-on reset, 0 is output until TIOR is set.

2. When the BFB bit in TMDR_0 is set to 1 and TGRD_0 is used as a buffer register, this setting is invalid and input capture/output compare is not generated.

Table 10.14 TIOR_1 (Channel 1)

				Description		
Bit 7 IOB3	Bit 6 IOB2	Bit 5 IOB1	Bit 4 IOB0	TGRB_1 Function	TIOC1B Pin Function	
0	0	0	0	Output compare register	Output retained*	
			1		Initial output is 0 0 output at compare match	
		1	0		Initial output is 0 1 output at compare match	
			1		Initial output is 0 Toggle output at compare match	
	1	0	0		Output retained	
			1		Initial output is 1 0 output at compare match	
			0		Initial output is 1 1 output at compare match	
		1	0		Initial output is 1 Toggle output at compare match	
			x		0	Input capture at rising edge
					1	Input capture at falling edge
1	x	x	1	Input capture at both edges		
			1	Input capture at generation of TGRC_0 compare match/input capture		

[Legend]

x: Don't care

Note: * After power-on reset, 0 is output until TIOR is set.

Table 10.15 TIOR_2 (Channel 2)

				Description	
Bit 7 IOB3	Bit 6 IOB2	Bit 5 IOB1	Bit 4 IOB0	TGRB_2 Function	TIOC2B Pin Function
0	0	0	0	Output compare register	Output retained*
			1		Initial output is 0 0 output at compare match
		1	0		Initial output is 0 1 output at compare match
			1		Initial output is 0 Toggle output at compare match
	1	0	0		Output retained
			1		Initial output is 1 0 output at compare match
			0		Initial output is 1 1 output at compare match
		1	0		Initial output is 1 Toggle output at compare match
			1		Initial output is 1 Toggle output at compare match
			1		Initial output is 1 Toggle output at compare match
1	x	0	Input capture register	Input capture at rising edge	
		1		Input capture at falling edge	
		1		Input capture at both edges	

[Legend]

x: Don't care

Note: * After power-on reset, 0 is output until TIOR is set.

Table 10.16 TIORH_3 (Channel 3)

				Description		
Bit 7 IOB3	Bit 6 IOB2	Bit 5 IOB1	Bit 4 IOB0	TGRB_3 Function	TIOC3B Pin Function	
0	0	0	0	Output compare register	Output retained*	
			1		Initial output is 0 0 output at compare match	
			0		Initial output is 0 1 output at compare match	
			1		Initial output is 0 Toggle output at compare match	
			0		Output retained	
			1		Initial output is 1 0 output at compare match	
		1	0	0	Input capture register	Input capture at rising edge
				1		Input capture at falling edge
				0		Initial output is 1 1 output at compare match
				1		Initial output is 1 Toggle output at compare match
				0		Input capture at both edges
				1		Input capture at both edges

[Legend]

x: Don't care

Note: * After power-on reset, 0 is output until TIOR is set.

Table 10.17 TIORL_3 (Channel 3)

				Description					
Bit 7 IOD3	Bit 6 IOD2	Bit 5 IOD1	Bit 4 IOD0	TGRD_3 Function	TIOC3D Pin Function				
0	0	0	0	Output compare register*2	Output retained*1				
			1		Initial output is 0 0 output at compare match				
			0		Initial output is 0 1 output at compare match				
			1		Initial output is 0 Toggle output at compare match				
			1		0	0	Output retained		
						1	Initial output is 1 0 output at compare match		
						0	Initial output is 1 1 output at compare match		
						1	Initial output is 1 Toggle output at compare match		
			1		x	0	0	Input capture register*2	Input capture at rising edge
							1		Input capture at falling edge
							1		Input capture at both edges

[Legend]

x: Don't care

Notes: 1. After power-on reset, 0 is output until TIOR is set.

2. When the BFB bit in TMDR_3 is set to 1 and TGRD_3 is used as a buffer register, this setting is invalid and input capture/output compare is not generated.

Table 10.18 TIORH_4 (Channel 4)

				Description	
Bit 7 IOB3	Bit 6 IOB2	Bit 5 IOB1	Bit 4 IOB0	TGRB_4 Function	TIOC4B Pin Function
0	0	0	0	Output compare register	Output retained*
			1		Initial output is 0 0 output at compare match
		1	0		Initial output is 0 1 output at compare match
			1		Initial output is 0 Toggle output at compare match
	1	0	0		Output retained
			1		Initial output is 1 0 output at compare match
		1	0		Initial output is 1 1 output at compare match
			1		Initial output is 1 Toggle output at compare match
1	x	0	0	Input capture register	Input capture at rising edge
			1		Input capture at falling edge
		1	x		Input capture at both edges

[Legend]

x: Don't care

Note: * After power-on reset, 0 is output until TIOR is set.

Table 10.19 TIORL_4 (Channel 4)

				Description					
Bit 7 IOD3	Bit 6 IOD2	Bit 5 IOD1	Bit 4 IOD0	TGRD_4 Function	TIOC4D Pin Function				
0	0	0	0	Output compare register*2	Output retained*1				
			1		Initial output is 0 0 output at compare match				
			0		Initial output is 0 1 output at compare match				
			1		Initial output is 0 Toggle output at compare match				
			1		0	0	Output retained		
						1	Initial output is 1 0 output at compare match		
						0	Initial output is 1 1 output at compare match		
						1	Initial output is 1 Toggle output at compare match		
			1		x	0	0	Input capture register*2	Input capture at rising edge
							1		Input capture at falling edge
							1		Input capture at both edges

[Legend]

x: Don't care

Notes: 1. After power-on reset, 0 is output until TIOR is set.

2. When the BFB bit in TMDR_4 is set to 1 and TGRD_4 is used as a buffer register, this setting is invalid and input capture/output compare is not generated.

Table 10.20 TIORH_0 (Channel 0)

				Description	
Bit 3 IOA3	Bit 2 IOA2	Bit 1 IOA1	Bit 0 IOA0	TGRA_0 Function	TIOC0A Pin Function
0	0	0	0	Output compare register	Output retained*
			1		Initial output is 0 0 output at compare match
		1	0		Initial output is 0 1 output at compare match
			1		Initial output is 0 Toggle output at compare match
	1	0	0	Output retained	
			1	Initial output is 1 0 output at compare match	
		1	0	Initial output is 1 1 output at compare match	
			1	Initial output is 1 Toggle output at compare match	
1	0	0	Input capture register	Input capture at rising edge	
		1		Input capture at falling edge	
	1	x		Input capture at both edges	
		1		x	Capture input source is channel 1/count clock Input capture at TCNT_1 count-up/count-down

[Legend]

x: Don't care

Note: * After power-on reset, 0 is output until TIOR is set.

Table 10.21 TIORL_0 (Channel 0)

				Description		
Bit 3 IOC3	Bit 2 IOC2	Bit 1 IOC1	Bit 0 IOC0	TGRC_0 Function	TIOC0C Pin Function	
0	0	0	0	Output compare register*2	Output retained*1	
			1		Initial output is 0 0 output at compare match	
			0		Initial output is 0 1 output at compare match	
		1	0		Initial output is 0 Toggle output at compare match	
			1		Output retained	
			0		Initial output is 1 0 output at compare match	
	1	0	0	1	Initial output is 1 1 output at compare match	
				1	Initial output is 1 Toggle output at compare match	
				0	Initial output is 1 Toggle output at compare match	
		1	x	x	0	Input capture register*2 Input capture at rising edge
					1	Input capture at falling edge
					x	Input capture at both edges
1	x	x	x		Capture input source is channel 1/count clock Input capture at TCNT_1 count-up/count-down	

[Legend]

x: Don't care

Notes: 1. After power-on reset, 0 is output until TIOR is set.

2. When the BFA bit in TMDR_0 is set to 1 and TGRC_0 is used as a buffer register, this setting is invalid and input capture/output compare is not generated.

Table 10.22 TIOR_1 (Channel 1)

				Description	
Bit 3 IOA3	Bit 2 IOA2	Bit 1 IOA1	Bit 0 IOA0	TGRA_1 Function	TIOC1A Pin Function
0	0	0	0	Output compare register	Output retained*
			1		Initial output is 0 0 output at compare match
		1	0		Initial output is 0 1 output at compare match
			1		Initial output is 0 Toggle output at compare match
	1	0	0	Output retained	
			1	Initial output is 1 0 output at compare match	
			1	Initial output is 1 1 output at compare match	
		1	0	Initial output is 1 1 output at compare match	
			1	Initial output is 1 Toggle output at compare match	
			1	Initial output is 1 Toggle output at compare match	
1	0	0	Input capture register	Input capture at rising edge	
		1		Input capture at falling edge	
		1		Input capture at both edges	
	1	x	Input capture at generation of channel 0/TGRA_0 compare match/input capture		

[Legend]

x: Don't care

Note: * After power-on reset, 0 is output until TIOR is set.

Table 10.23 TIOR_2 (Channel 2)

				Description	
Bit 3 IOA3	Bit 2 IOA2	Bit 1 IOA1	Bit 0 IOA0	TGRA_2 Function	TIOC2A Pin Function
0	0	0	0	Output compare register	Output retained*
			1		Initial output is 0 0 output at compare match
		1	0		Initial output is 0 1 output at compare match
			1		Initial output is 0 Toggle output at compare match
	1	0	0	Output retained	
			1	Initial output is 1 0 output at compare match	
			0	Initial output is 1 1 output at compare match	
		1	0	Initial output is 1 Toggle output at compare match	
			1	Initial output is 1	
			1	Toggle output at compare match	
1	x	0	0	Input capture register	Input capture at rising edge
			1		Input capture at falling edge
		1	x		Input capture at both edges

[Legend]

x: Don't care

Note: * After power-on reset, 0 is output until TIOR is set.

Table 10.24 TIORH_3 (Channel 3)

				Description	
Bit 3 IOA3	Bit 2 IOA2	Bit 1 IOA1	Bit 0 IOA0	TGRA_3 Function	TIOC3A Pin Function
0	0	0	0	Output compare register	Output retained*
			1		Initial output is 0 0 output at compare match
		1	0		Initial output is 0 1 output at compare match
			1		Initial output is 0 Toggle output at compare match
	1	0	0	Output retained	
			1	Initial output is 1 0 output at compare match	
			1	Initial output is 1 1 output at compare match	
		1	0	Initial output is 1 1 output at compare match	
			1	Initial output is 1 Toggle output at compare match	
			x	Input capture at rising edge	
1	x	0	Input capture register	Input capture at rising edge	
		1		Input capture at falling edge	
		1		Input capture at both edges	

[Legend]

x: Don't care

Note: * After power-on reset, 0 is output until TIOR is set.

Table 10.25 TIORL_3 (Channel 3)

				Description				
Bit 3 IOC3	Bit 2 IOC2	Bit 1 IOC1	Bit 0 IOC0	TGRC_3 Function	TIOC3C Pin Function			
0	0	0	0	Output compare register*2	Output retained*1			
			1		Initial output is 0 0 output at compare match			
			0		Initial output is 0 1 output at compare match			
			1		Initial output is 0 Toggle output at compare match			
		1	0	0	0	Output retained		
					1	Initial output is 1 0 output at compare match		
				1	0	Initial output is 1 1 output at compare match		
					1	Initial output is 1 Toggle output at compare match		
				1	x	0	0	Input capture register*2 Input capture at rising edge
							1	Input capture at falling edge
1	Input capture at both edges							

[Legend]

x: Don't care

Notes: 1. After power-on reset, 0 is output until TIOR is set.

2. When the BFA bit in TMDR_3 is set to 1 and TGRC_3 is used as a buffer register, this setting is invalid and input capture/output compare is not generated.

Table 10.26 TIORH_4 (Channel 4)

				Description		
Bit 3 IOA3	Bit 2 IOA2	Bit 1 IOA1	Bit 0 IOA0	TGRA_4 Function	TIOC4A Pin Function	
0	0	0	0	Output compare register	Output retained*	
			1		Initial output is 0 0 output at compare match	
		1	0		Initial output is 0 1 output at compare match	
			1		Initial output is 0 Toggle output at compare match	
	1	0	0	0	Output retained	
				1	Initial output is 1 0 output at compare match	
			1	0	Initial output is 1 1 output at compare match	
				1	Initial output is 1 Toggle output at compare match	
		x	0	0	Input capture register	Input capture at rising edge
				1		Input capture at falling edge
			1	x		Input capture at both edges

[Legend]

x: Don't care

Note: * After power-on reset, 0 is output until TIOR is set.

Table 10.27 TIORL_4 (Channel 4)

				Description					
Bit 3 IOC3	Bit 2 IOC2	Bit 1 IOC1	Bit 0 IOC0	TGRC_4 Function	TIOC4C Pin Function				
0	0	0	0	Output compare register*2	Output retained*1				
			1		Initial output is 0 0 output at compare match				
			0		Initial output is 0 1 output at compare match				
			1		Initial output is 0 Toggle output at compare match				
			1		0	0	Output retained		
						1	Initial output is 1 0 output at compare match		
						0	Initial output is 1 1 output at compare match		
						1	Initial output is 1 Toggle output at compare match		
			1		x	0	0	Input capture register*2	Input capture at rising edge
							1		Input capture at falling edge
1	Input capture at both edges								

[Legend]

x: Don't care

Notes: 1. After power-on reset, 0 is output until TIOR is set.

2. When the BFA bit in TMDR_4 is set to 1 and TGRC_4 is used as a buffer register, this setting is invalid and input capture/output compare is not generated.

Table 10.28 TIORU_5, TIORV_5, and TIORW_5 (Channel 5)

					Description						
Bit 4 IOC4	Bit 3 IOC3	Bit 2 IOC2	Bit 1 IOC1	Bit 0 IOC0	TGRU_5, TGRV_5, and TGRW_5 Function	TIC5U, TIC5V, and TIC5W Pin Function					
0	0	0	0	0	Compare match register	Compare match					
				1		Setting prohibited					
				1		x	Setting prohibited				
				1		x	Setting prohibited				
				1		x	x	Setting prohibited			
1	0	0	0	0	Input capture register	Setting prohibited					
				1		Input capture at rising edge					
				1		0	Input capture at falling edge				
				1		1	Input capture at both edges				
				1		x	x	Setting prohibited			
				1		0	0	0	0	Setting prohibited	
									1	Measurement of low pulse width of external input signal Capture at trough of complementary PWM mode	
									1	0	Measurement of low pulse width of external input signal Capture at crest of complementary PWM mode
				1		0	0	0	1	Measurement of low pulse width of external input signal Capture at crest and trough of complementary PWM mode	
									1	0	Setting prohibited
									1	1	Measurement of high pulse width of external input signal Capture at trough of complementary PWM mode
				1		0	0	1	0	Measurement of high pulse width of external input signal Capture at crest of complementary PWM mode	
									1	0	Measurement of high pulse width of external input signal Capture at crest and trough of complementary PWM mode
									1	1	Measurement of high pulse width of external input signal Capture at crest and trough of complementary PWM mode

[Legend]

x: Don't care

10.3.4 Timer Compare Match Clear Register (TCNTCMPCLR)

TCNTCMPCLR is an 8-bit readable/writable register that specifies requests to clear TCNTU_5, TCNTV_5, and TCNTW_5. The MTU2 has one TCNTCMPCLR in channel 5.

Bit:	7	6	5	4	3	2	1	0
	-	-	-	-	-	CMP CLB5U	CMP CLB5V	CMP CLB5W
Initial value:	0	0	0	0	0	0	0	0
R/W:	R	R	R	R	R	R/W	R/W	R/W

Bit	Bit Name	Initial Value	R/W	Description
7 to 3	—	All 0	R	Reserved These bits are always read as 0. The write value should always be 0.
2	CMPCLR5U	0	R/W	TCNT Compare Clear 5U Enables or disables requests to clear TCNTU_5 at TGRU_5 compare match or input capture. 0: Disables TCNTU_5 to be cleared to H'0000 at TCNTU_5 and TGRU_5 compare match or input capture 1: Enables TCNTU_5 to be cleared to H'0000 at TCNTU_5 and TGRU_5 compare match or input capture
1	CMPCLR5V	0	R/W	TCNT Compare Clear 5V Enables or disables requests to clear TCNTV_5 at TGRV_5 compare match or input capture. 0: Disables TCNTV_5 to be cleared to H'0000 at TCNTV_5 and TGRV_5 compare match or input capture 1: Enables TCNTV_5 to be cleared to H'0000 at TCNTV_5 and TGRV_5 compare match or input capture

Bit	Bit Name	Initial Value	R/W	Description
0	CMPCLR5W	0	R/W	<p>TCNT Compare Clear 5W</p> <p>Enables or disables requests to clear TCNTW_5 at TGRW_5 compare match or input capture.</p> <p>0: Disables TCNTW_5 to be cleared to H'0000 at TCNTW_5 and TGRW_5 compare match or input capture</p> <p>1: Enables TCNTW_5 to be cleared to H'0000 at TCNTW_5 and TGRW_5 compare match or input capture</p>

10.3.5 Timer Interrupt Enable Register (TIER)

The TIER registers are 8-bit readable/writable registers that control enabling or disabling of interrupt requests for each channel. The MTU2 has seven TIER registers, two for channel 0 and one each for channels 1 to 5.

- TIER_0, TIER_1, TIER_2, TIER_3, TIER_4

Bit:	7	6	5	4	3	2	1	0
	TTGE	TTGE2	TCIEU	TCIEV	TGIED	TGIEC	TGIEB	TGIEA
Initial value:	0	0	0	0	0	0	0	0
R/W:	R/W	R/W	R/W	R/W	R/W	R/W	R/W	R/W

Bit	Bit Name	Initial Value	R/W	Description
7	TTGE	0	R/W	<p>A/D Converter Start Request Enable</p> <p>Enables or disables generation of A/D converter start requests by TGRA input capture/compare match.</p> <p>0: A/D converter start request generation disabled</p> <p>1: A/D converter start request generation enabled</p>

Bit	Bit Name	Initial Value	R/W	Description
6	TTGE2	0	R/W	<p>A/D Converter Start Request Enable 2</p> <p>Enables or disables generation of A/D converter start requests by TCNT_4 underflow (trough) in complementary PWM mode.</p> <p>In channels 0 to 3, bit 6 is reserved. It is always read as 0 and the write value should always be 0.</p> <p>0: A/D converter start request generation by TCNT_4 underflow (trough) disabled</p> <p>1: A/D converter start request generation by TCNT_4 underflow (trough) enabled</p>
5	TCIEU	0	R/W	<p>Underflow Interrupt Enable</p> <p>Enables or disables interrupt requests (TCIU) by the TCFU flag when the TCFU flag in TSR is set to 1 in channels 1 and 2.</p> <p>In channels 0, 3, and 4, bit 5 is reserved. It is always read as 0 and the write value should always be 0.</p> <p>0: Interrupt requests (TCIU) by TCFU disabled</p> <p>1: Interrupt requests (TCIU) by TCFU enabled</p>
4	TCIEV	0	R/W	<p>Overflow Interrupt Enable</p> <p>Enables or disables interrupt requests (TCIV) by the TCFV flag when the TCFV flag in TSR is set to 1.</p> <p>0: Interrupt requests (TCIV) by TCFV disabled</p> <p>1: Interrupt requests (TCIV) by TCFV enabled</p>
3	TGIED	0	R/W	<p>TGR Interrupt Enable D</p> <p>Enables or disables interrupt requests (TGID) by the TGFD bit when the TGFD bit in TSR is set to 1 in channels 0, 3, and 4.</p> <p>In channels 1 and 2, bit 3 is reserved. It is always read as 0 and the write value should always be 0.</p> <p>0: Interrupt requests (TGID) by TGFD bit disabled</p> <p>1: Interrupt requests (TGID) by TGFD bit enabled</p>

Bit	Bit Name	Initial Value	R/W	Description
2	TGIEC	0	R/W	<p>TGR Interrupt Enable C</p> <p>Enables or disables interrupt requests (TGIC) by the TGFC bit when the TGFC bit in TSR is set to 1 in channels 0, 3, and 4.</p> <p>In channels 1 and 2, bit 2 is reserved. It is always read as 0 and the write value should always be 0.</p> <p>0: Interrupt requests (TGIC) by TGFC bit disabled 1: Interrupt requests (TGIC) by TGFC bit enabled</p>
1	TGIEB	0	R/W	<p>TGR Interrupt Enable B</p> <p>Enables or disables interrupt requests (TGIB) by the TGFB bit when the TGFB bit in TSR is set to 1.</p> <p>0: Interrupt requests (TGIB) by TGFB bit disabled 1: Interrupt requests (TGIB) by TGFB bit enabled</p>
0	TGIEA	0	R/W	<p>TGR Interrupt Enable A</p> <p>Enables or disables interrupt requests (TGIA) by the TGFA bit when the TGFA bit in TSR is set to 1.</p> <p>0: Interrupt requests (TGIA) by TGFA bit disabled 1: Interrupt requests (TGIA) by TGFA bit enabled</p>

- TIER2_0

Bit:	7	6	5	4	3	2	1	0
	TTGE2	-	-	-	-	-	TGIEF	TGIEE
Initial value:	0	0	0	0	0	0	0	0
R/W:	R/W	R	R	R	R	R	R/W	R/W

Bit	Bit Name	Initial Value	R/W	Description
7	TTGE2	0	R/W	<p>A/D Converter Start Request Enable 2</p> <p>Enables or disables generation of A/D converter start requests by compare match between TCNT_0 and TGRE_0.</p> <p>0: A/D converter start request generation by compare match between TCNT_0 and TGRE_0 disabled</p> <p>1: A/D converter start request generation by compare match between TCNT_0 and TGRE_0 enabled</p>
6 to 2	—	All 0	R	<p>Reserved</p> <p>These bits are always read as 0. The write value should always be 0.</p>
1	TGIEF	0	R/W	<p>TGR Interrupt Enable F</p> <p>Enables or disables interrupt requests by compare match between TCNT_0 and TGRF_0.</p> <p>0: Interrupt requests (TGIF) by TGFE bit disabled</p> <p>1: Interrupt requests (TGIF) by TGFE bit enabled</p>
0	TGIEE	0	R/W	<p>TGR Interrupt Enable E</p> <p>Enables or disables interrupt requests by compare match between TCNT_0 and TGRE_0.</p> <p>0: Interrupt requests (TGIE) by TGEE bit disabled</p> <p>1: Interrupt requests (TGIE) by TGEE bit enabled</p>

- TIER_5

Bit:	7	6	5	4	3	2	1	0
	-	-	-	-	-	TGIE5U	TGIE5V	TGIE5W
Initial value:	0	0	0	0	0	0	0	0
R/W:	R	R	R	R	R	R/W	R/W	R/W

Bit	Bit Name	Initial Value	R/W	Description
7 to 3	—	All 0	R	Reserved These bits are always read as 0. The write value should always be 0.
2	TGIE5U	0	R/W	TGR Interrupt Enable 5U Enables or disables interrupt requests (TGIU_5) by the CMFU5 bit when the CMFU5 bit in TSR_5 is set to 1. 0: Interrupt requests (TGIU_5) disabled 1: Interrupt requests (TGIU_5) enabled
1	TGIE5V	0	R/W	TGR Interrupt Enable 5V Enables or disables interrupt requests (TGIV_5) by the CMFV5 bit when the CMFV5 bit in TSR_5 is set to 1. 0: Interrupt requests (TGIV_5) disabled 1: Interrupt requests (TGIV_5) enabled
0	TGIE5W	0	R/W	TGR Interrupt Enable 5W Enables or disables interrupt requests (TGIW_5) by the CMFW5 bit when the CMFW5 bit in TSR_5 is set to 1. 0: Interrupt requests (TGIW_5) disabled 1: Interrupt requests (TGIW_5) enabled

10.3.6 Timer Status Register (TSR)

The TSR registers are 8-bit readable/writable registers that indicate the status of each channel. The MTU2 has seven TSR registers, two for channel 0 and one each for channels 1 to 5.

- TSR_0, TSR_1, TSR_2, TSR_3, TSR_4

Bit:	7	6	5	4	3	2	1	0
	TCFD	-	TCFU	TCFV	TGFD	TGFC	TGFB	TGFA
Initial value:	1	1	0	0	0	0	0	0
R/W:	R	R	R/(W)*	R/(W)*	R/(W)*	R/(W)*	R/(W)*	R/(W)*

Note: * Writing 0 to this bit after reading it as 1 clears the flag and is the only allowed way.

Bit	Bit Name	Initial Value	R/W	Description
7	TCFD	1	R	Count Direction Flag Status flag that shows the direction in which TCNT counts in channels 1 to 4. In channel 0, bit 7 is reserved. It is always read as 1 and the write value should always be 1. 0: TCNT counts down 1: TCNT counts up
6	—	1	R	Reserved This bit is always read as 1. The write value should always be 1.
5	TCFU	0	R/(W)* ¹	Underflow Flag Status flag that indicates that TCNT underflow has occurred when channels 1 and 2 are set to phase counting mode. Only 0 can be written, for flag clearing. In channels 0, 3, and 4, bit 5 is reserved. It is always read as 0 and the write value should always be 0. [Setting condition] <ul style="list-style-type: none"> • When the TCNT value underflows (changes from H'0000 to H'FFFF) [Clearing condition] <ul style="list-style-type: none"> • When 0 is written to TCFU after reading TCFU = 1*²

Bit	Bit Name	Initial Value	R/W	Description
4	TCFV	0	R/(W)* ¹	<p>Overflow Flag</p> <p>Status flag that indicates that TCNT overflow has occurred. Only 0 can be written, for flag clearing.</p> <p>[Setting condition]</p> <ul style="list-style-type: none"> When the TCNT value overflows (changes from H'FFFF to H'0000) In channel 4, when the TCNT_4 value underflows (changes from H'0001 to H'0000) in complementary PWM mode, this flag is also set. <p>[Clearing condition]</p> <ul style="list-style-type: none"> When 0 is written to TCFV after reading TCFV = 1*² In channel 4, when DTC is activated by TCIV interrupt and the DISEL bit of MRB in DTC is 0, this flag is also cleared.
3	TGFD	0	R/(W)* ¹	<p>Input Capture/Output Compare Flag D</p> <p>Status flag that indicates the occurrence of TGRD input capture or compare match in channels 0, 3, and 4. Only 0 can be written, for flag clearing. In channels 1 and 2, bit 3 is reserved. It is always read as 0 and the write value should always be 0.</p> <p>[Setting conditions]</p> <ul style="list-style-type: none"> When TCNT = TGRD and TGRD is functioning as output compare register When TCNT value is transferred to TGRD by input capture signal and TGRD is functioning as input capture register <p>[Clearing conditions]</p> <ul style="list-style-type: none"> When DTC is activated by TGID interrupt and the DISEL bit of MRB in DTC is 0 When 0 is written to TGFD after reading TGFD = 1*²

Bit	Bit Name	Initial Value	R/W	Description
2	TGFC	0	R/(W)* ¹	<p>Input Capture/Output Compare Flag C</p> <p>Status flag that indicates the occurrence of TGRC input capture or compare match in channels 0, 3, and 4. Only 0 can be written, for flag clearing. In channels 1 and 2, bit 2 is reserved. It is always read as 0 and the write value should always be 0.</p> <p>[Setting conditions]</p> <ul style="list-style-type: none"> • When TCNT = TGRC and TGRC is functioning as output compare register • When TCNT value is transferred to TGRC by input capture signal and TGRC is functioning as input capture register <p>[Clearing conditions]</p> <ul style="list-style-type: none"> • When DTC is activated by TGIC interrupt and the DISEL bit of MRB in DTC is 0 • When 0 is written to TGFC after reading TGFC = 1*²
1	TGFB	0	R/(W)* ¹	<p>Input Capture/Output Compare Flag B</p> <p>Status flag that indicates the occurrence of TGRB input capture or compare match. Only 0 can be written, for flag clearing.</p> <p>[Setting conditions]</p> <ul style="list-style-type: none"> • When TCNT = TGRB and TGRB is functioning as output compare register • When TCNT value is transferred to TGRB by input capture signal and TGRB is functioning as input capture register <p>[Clearing conditions]</p> <ul style="list-style-type: none"> • When DTC is activated by TGIB interrupt and the DISEL bit of MRB in DTC is 0 • When 0 is written to TGFB after reading TGFB = 1*²

Bit	Bit Name	Initial Value	R/W	Description
0	TGFA	0	R/(W)* ¹	<p>Input Capture/Output Compare Flag A</p> <p>Status flag that indicates the occurrence of TGRA input capture or compare match. Only 0 can be written, for flag clearing.</p> <p>[Setting conditions]</p> <ul style="list-style-type: none"> • When TCNT = TGRA and TGRA is functioning as output compare register • When TCNT value is transferred to TGRA by input capture signal and TGRA is functioning as input capture register <p>[Clearing conditions]</p> <ul style="list-style-type: none"> • When DTC is activated by TGIA interrupt and the DISEL bit of MRB in DTC is 0 • When 0 is written to TGFA after reading TGFA = 1*²

Notes: 1. Writing 0 to this bit after reading it as 1 clears the flag and is the only allowed way.
2. If another flag setting condition occurs before writing 0 to the bit after reading it as 1, the flag will not be cleared by writing 0 to it once. In this case, read the bit as 1 again and write 0 to it.

- TSR2_0

Bit:	7	6	5	4	3	2	1	0
	-	-	-	-	-	-	TGFF	TGFE
Initial value:	1	1	0	0	0	0	0	0
R/W:	R	R	R	R	R	R	R/(W)*	R/(W)*

Note: * Writing 0 to this bit after reading it as 1 clears the flag and is the only allowed way.

Bit	Bit Name	Initial Value	R/W	Description
7, 6	—	All 1	R	Reserved These bits are always read as 1. The write value should always be 1.
5 to 2	—	All 0	R	Reserved These bits are always read as 0. The write value should always be 0.
1	TGFF	0	R/(W)* ¹	Compare Match Flag F Status flag that indicates the occurrence of compare match between TCNT_0 and TGRF_0. [Setting condition] <ul style="list-style-type: none"> • When TCNT_0 = TGRF_0 and TGRF_0 is functioning as compare register [Clearing condition] <ul style="list-style-type: none"> • When 0 is written to TGFF after reading TGFF = 1*²
0	TGFE	0	R/(W)* ¹	Compare Match Flag E Status flag that indicates the occurrence of compare match between TCNT_0 and TGRE_0. [Setting condition] <ul style="list-style-type: none"> • When TCNT_0 = TGRE_0 and TGRE_0 is functioning as compare register [Clearing condition] <ul style="list-style-type: none"> • When 0 is written to TGFE after reading TGFE = 1*²

Notes: 1. Writing 0 to this bit after reading it as 1 clears the flag and is the only allowed way.
 2. If another flag setting condition occurs before writing 0 to the bit after reading it as 1, the flag will not be cleared by writing 0 to it once. In this case, read the bit as 1 again and write 0 to it.

- **TSR_5**

Bit:	7	6	5	4	3	2	1	0
	-	-	-	-	-	CMFU5	CMFU5	CMFU5
Initial value:	0	0	0	0	0	0	0	0
R/W:	R	R	R	R	R	R/(W)*	R/(W)*	R/(W)*

Note: * Writing 0 to this bit after reading it as 1 clears the flag and is the only allowed way.

Bit	Bit Name	Initial Value	R/W	Description
7 to 3	—	All 0	R	Reserved These bits are always read as 0. The write value should always be 0.
2	CMFU5	0	R/(W)* ¹	Compare Match/Input Capture Flag U5 Status flag that indicates the occurrence of TGRU_5 input capture or compare match. [Setting conditions] <ul style="list-style-type: none"> • When TCNTU_5 = TGRU_5 and TGRU_5 is functioning as output compare register • When TCNTU_5 value is transferred to TGRU_5 by input capture signal and TGRU_5 is functioning as input capture register • When TCNTU_5 value is transferred to TGRU_5 and TGRU_5 is functioning as a register for measuring the pulse width of the external input signal. The transfer timing is specified by the IOC bits in timer I/O control register U_5 (TIORU_5)*² [Clearing conditions] <ul style="list-style-type: none"> • When DTC is activated by a TGIU_5 interrupt and the DISEL bit of MRB in DTC is 0 • When 0 is written to CMFU5 after reading CMFU5 = 1

Bit	Bit Name	Initial Value	R/W	Description
1	CMFV5	0	R/(W)* ¹	<p>Compare Match/Input Capture Flag V5</p> <p>Status flag that indicates the occurrence of TGRV_5 input capture or compare match.</p> <p>[Setting conditions]</p> <ul style="list-style-type: none"> • When TCNTV_5 = TGRV_5 and TGRV_5 is functioning as output compare register • When TCNTV_5 value is transferred to TGRV_5 by input capture signal and TGRV_5 is functioning as input capture register • When TCNTV_5 value is transferred to TGRV_5 and TGRV_5 is functioning as a register for measuring the pulse width of the external input signal. The transfer timing is specified by the IOC bits in timer I/O control register V_5 (TIORV_5)*² <p>[Clearing conditions]</p> <ul style="list-style-type: none"> • When DTC is activated by a TGIV_5 interrupt and the DISEL bit of MRB in DTC is 0 • When 0 is written to CMFV5 after reading CMFV5 = 1

Bit	Bit Name	Initial Value	R/W	Description
0	CMFW5	0	R/(W)* ¹	<p>Compare Match/Input Capture Flag W5</p> <p>Status flag that indicates the occurrence of TGRW_5 input capture or compare match.</p> <p>[Setting conditions]</p> <ul style="list-style-type: none"> • When TCNTW_5 = TGRW_5 and TGRW_5 is functioning as output compare register • When TCNTW_5 value is transferred to TGRW_5 by input capture signal and TGRW_5 is functioning as input capture register • When TCNTW_5 value is transferred to TGRW_5 and TGRW_5 is functioning as a register for measuring the pulse width of the external input signal. The transfer timing is specified by the IOC bits in timer I/O control register W_5 (TIORW_5)*² <p>[Clearing conditions]</p> <ul style="list-style-type: none"> • When DTC is activated by a TGIW_5 interrupt and the DISEL bit of MRB in DTC is 0 • When 0 is written to CMFW5 after reading CMFW5 = 1

Notes: 1. Writing 0 to this bit after reading it as 1 clears the flag and is the only allowed way.

2. The transfer timing is specified by the IOC bit in timer I/O control registers U_5/V_5/W_5 (TIORU_5, TIORV_5, TIORW_5).

10.3.7 Timer Buffer Operation Transfer Mode Register (TBTM)

The TBTM registers are 8-bit readable/writable registers that specify the timing for transferring data from the buffer register to the timer general register in PWM mode. The MTU2 has three TBTM registers, one each for channels 0, 3, and 4.

Bit:	7	6	5	4	3	2	1	0
	-	-	-	-	-	TTSE	TTSB	TTSA
Initial value:	0	0	0	0	0	0	0	0
R/W:	R	R	R	R	R	R/W	R/W	R/W

Bit	Bit Name	Initial Value	R/W	Description
7 to 3	—	All 0	R	Reserved These bits are always read as 0. The write value should always be 0.
2	TTSE	0	R/W	Timing Select E Specifies the timing for transferring data from TGRF_0 to TGRE_0 when they are used together for buffer operation. In channels 3 and 4, bit 2 is reserved. It is always read as 0 and the write value should always be 0. When using channel 0 in other than PWM mode, do not set this bit to 1. 0: When compare match E occurs in channel 0 1: When TCNT_0 is cleared
1	TTSB	0	R/W	Timing Select B Specifies the timing for transferring data from TGRD to TGRB in each channel when they are used together for buffer operation. When using a channel in other than PWM mode, do not set this bit to 1. 0: When compare match B occurs in each channel 1: When TCNT is cleared in each channel

Bit	Bit Name	Initial Value	R/W	Description
0	TTSA	0	R/W	Timing Select A Specifies the timing for transferring data from TGRC to TGRA in each channel when they are used together for buffer operation. When using a channel in other than PWM mode, do not set this bit to 1. 0: When compare match A occurs in each channel 1: When TCNT is cleared in each channel

10.3.8 Timer Input Capture Control Register (TICCR)

TICCR is an 8-bit readable/writable register that specifies input capture conditions when TCNT_1 and TCNT_2 are cascaded. The MTU2 has one TICCR in channel 1.

Bit:	7	6	5	4	3	2	1	0
	-	-	-	-	I2BE	I2AE	I1BE	I1AE
Initial value:	0	0	0	0	0	0	0	0
R/W:	R	R	R	R	R/W	R/W	R/W	R/W

Bit	Bit Name	Initial Value	R/W	Description
7 to 4	—	All 0	R	Reserved These bits are always read as 0. The write value should always be 0.
3	I2BE	0	R/W	Input Capture Enable Specifies whether to include the TIOC2B pin in the TGRB_1 input capture conditions. 0: Does not include the TIOC2B pin in the TGRB_1 input capture conditions 1: Includes the TIOC2B pin in the TGRB_1 input capture conditions

Bit	Bit Name	Initial Value	R/W	Description
2	I2AE	0	R/W	<p>Input Capture Enable</p> <p>Specifies whether to include the TIOC2A pin in the TGRA_1 input capture conditions.</p> <p>0: Does not include the TIOC2A pin in the TGRA_1 input capture conditions</p> <p>1: Includes the TIOC2A pin in the TGRA_1 input capture conditions</p>
1	I1BE	0	R/W	<p>Input Capture Enable</p> <p>Specifies whether to include the TIOC1B pin in the TGRB_2 input capture conditions.</p> <p>0: Does not include the TIOC1B pin in the TGRB_2 input capture conditions</p> <p>1: Includes the TIOC1B pin in the TGRB_2 input capture conditions</p>
0	I1AE	0	R/W	<p>Input Capture Enable</p> <p>Specifies whether to include the TIOC1A pin in the TGRA_2 input capture conditions.</p> <p>0: Does not include the TIOC1A pin in the TGRA_2 input capture conditions</p> <p>1: Includes the TIOC1A pin in the TGRA_2 input capture conditions</p>

10.3.9 Timer Synchronous Clear Register (TSYCR)

TSYCR is an 8-bit readable/writable register that specifies conditions for clearing TCNT_3 and TCNT_4 in the MTU2S in synchronization with the MTU2. The MTU2S has one TSYCR in channel 3 but the MTU2 has no TSYCR.

Bit:	7	6	5	4	3	2	1	0
	CE0A	CE0B	CE0C	CE0D	CE1A	CE1B	CE2A	CE2B
Initial value:	0	0	0	0	0	0	0	0
R/W:	R/W	R/W	R/W	R/W	R/W	R/W	R/W	R/W

Bit	Bit Name	Initial Value	R/W	Description
7	CE0A	0	R/W	Clear Enable 0A Enables or disables counter clearing when the TGFA flag of TSR_0 in the MTU2 is set. 0: Disables counter clearing by the TGFA flag in TSR_0 1: Enables counter clearing by the TGFA flag in TSR_0
6	CE0B	0	R/W	Clear Enable 0B Enables or disables counter clearing when the TGFB flag of TSR_0 in the MTU2 is set. 0: Disables counter clearing by the TGFB flag in TSR_0 1: Enables counter clearing by the TGFB flag in TSR_0
5	CE0C	0	R/W	Clear Enable 0C Enables or disables counter clearing when the TGFC flag of TSR_0 in the MTU2 is set. 0: Disables counter clearing by the TGFC flag in TSR_0 1: Enables counter clearing by the TGFC flag in TSR_0
4	CE0D	0	R/W	Clear Enable 0D Enables or disables counter clearing when the TGFD flag of TSR_0 in the MTU2 is set. 0: Disables counter clearing by the TGFD flag in TSR_0 1: Enables counter clearing by the TGFD flag in TSR_0

Bit	Bit Name	Initial Value	R/W	Description
3	CE1A	0	R/W	<p>Clear Enable 1A</p> <p>Enables or disables counter clearing when the TGFA flag of TSR_1 in the MTU2 is set.</p> <p>0: Disables counter clearing by the TGFA flag in TSR_1</p> <p>1: Enables counter clearing by the TGFA flag in TSR_1</p>
2	CE1B	0	R/W	<p>Clear Enable 1B</p> <p>Enables or disables counter clearing when the TGFB flag of TSR_1 in the MTU2 is set.</p> <p>0: Disables counter clearing by the TGFB flag in TSR_1</p> <p>1: Enables counter clearing by the TGFB flag in TSR_1</p>
1	CE2A	0	R/W	<p>Clear Enable 2A</p> <p>Enables or disables counter clearing when the TGFA flag of TSR_2 in the MTU2 is set.</p> <p>0: Disables counter clearing by the TGFA flag in TSR_2</p> <p>1: Enables counter clearing by the TGFA flag in TSR_2</p>
0	CE2B	0	R/W	<p>Clear Enable 2B</p> <p>Enables or disables counter clearing when the TGFB flag of TSR_2 in the MTU2 is set.</p> <p>0: Disables counter clearing by the TGFB flag in TSR_2</p> <p>1: Enables counter clearing by the TGFB flag in TSR_2</p>

10.3.10 Timer A/D Converter Start Request Control Register (TADCR)

TADCR is a 16-bit readable/writable register that enables or disables A/D converter start requests and specifies whether to link A/D converter start requests with interrupt skipping operation. The MTU2 has one TADCR in channel 4.

Bit:	15	14	13	12	11	10	9	8	7	6	5	4	3	2	1	0
	BF[1:0]	-	-	-	-	-	-	-	UT4AE	DT4AE	UT4BE	DT4BE	ITA3AE	ITA4VE	ITB3AE	ITB4VE
Initial value:	0	0	0	0	0	0	0	0	0	0*	0	0*	0*	0*	0*	0*
R/W:	R/W	R/W	R	R	R	R	R	R	R/W	R/W	R/W	R/W	R/W	R/W	R/W	R/W

Note: * Do not set to 1 when complementary PWM mode is not selected.

Bit	Bit Name	Initial Value	R/W	Description
15, 14	BF[1:0]	00	R/W	TADCOBRA_4/TADCOBRB_4 Transfer Timing Select Select the timing for transferring data from TADCOBRA_4 and TADCOBRB_4 to TADCORA_4 and TADCORB_4. For details, see table 10.29.
13 to 8	—	All 0	R	Reserved These bits are always read as 0. The write value should always be 0.
7	UT4AE	0	R/W	Up-Count TRG4AN Enable Enables or disables A/D converter start requests (TRG4AN) during TCNT_4 up-count operation. 0: A/D converter start requests (TRG4AN) disabled during TCNT_4 up-count operation 1: A/D converter start requests (TRG4AN) enabled during TCNT_4 up-count operation
6	DT4AE	0*	R/W	Down-Count TRG4AN Enable Enables or disables A/D converter start requests (TRG4AN) during TCNT_4 down-count operation. 0: A/D converter start requests (TRG4AN) disabled during TCNT_4 down-count operation 1: A/D converter start requests (TRG4AN) enabled during TCNT_4 down-count operation

Bit	Bit Name	Initial Value	R/W	Description
5	UT4BE	0	R/W	<p>Up-Count TRG4BN Enable</p> <p>Enables or disables A/D converter start requests (TRG4BN) during TCNT_4 up-count operation.</p> <p>0: A/D converter start requests (TRG4BN) disabled during TCNT_4 up-count operation</p> <p>1: A/D converter start requests (TRG4BN) enabled during TCNT_4 up-count operation</p>
4	DT4BE	0*	R/W	<p>Down-Count TRG4BN Enable</p> <p>Enables or disables A/D converter start requests (TRG4BN) during TCNT_4 down-count operation.</p> <p>0: A/D converter start requests (TRG4BN) disabled during TCNT_4 down-count operation</p> <p>1: A/D converter start requests (TRG4BN) enabled during TCNT_4 down-count operation</p>
3	ITA3AE	0*	R/W	<p>TGIA_3 Interrupt Skipping Link Enable</p> <p>Select whether to link A/D converter start requests (TRG4AN) with TGIA_3 interrupt skipping operation.</p> <p>0: Does not link with TGIA_3 interrupt skipping</p> <p>1: Links with TGIA_3 interrupt skipping</p>
2	ITA4VE	0*	R/W	<p>TCIV_4 Interrupt Skipping Link Enable</p> <p>Select whether to link A/D converter start requests (TRG4AN) with TCIV_4 interrupt skipping operation.</p> <p>0: Does not link with TCIV_4 interrupt skipping</p> <p>1: Links with TCIV_4 interrupt skipping</p>
1	ITB3AE	0*	R/W	<p>TGIA_3 Interrupt Skipping Link Enable</p> <p>Select whether to link A/D converter start requests (TRG4BN) with TGIA_3 interrupt skipping operation.</p> <p>0: Does not link with TGIA_3 interrupt skipping</p> <p>1: Links with TGIA_3 interrupt skipping</p>

Bit	Bit Name	Initial Value	R/W	Description
0	ITB4VE	0*	R/W	TCIV_4 Interrupt Skipping Link Enable Select whether to link A/D converter start requests (TRG4BN) with TCIV_4 interrupt skipping operation. 0: Does not link with TCIV_4 interrupt skipping 1: Links with TCIV_4 interrupt skipping

- Notes:
1. TADCR must not be accessed in eight bits; it should always be accessed in 16 bits.
 2. When interrupt skipping is disabled (the T3AEN and T4VEN bits in the timer interrupt skipping set register (TITCR) are cleared to 0 or the skipping count set bits (3ACOR and 4VCOR) in TITCR are cleared to 0), do not link A/D converter start requests with interrupt skipping operation (clear the ITA3AE, ITA4VE, ITB3AE, and ITB4VE bits in the timer A/D converter start request control register (TADCR) to 0).
 3. If link with interrupt skipping is enabled while interrupt skipping is disabled, A/D converter start requests will not be issued.
- * Do not set to 1 when complementary PWM mode is not selected.

Table 10.29 Setting of Transfer Timing by BF1 and BF0 Bits

Bit 7	Bit 6	Description
BF1	BF0	
0	0	Does not transfer data from the cycle set buffer register to the cycle set register.
0	1	Transfers data from the cycle set buffer register to the cycle set register at the crest of the TCNT_4 count.* ¹
1	0	Transfers data from the cycle set buffer register to the cycle set register at the trough of the TCNT_4 count.* ²
1	1	Transfers data from the cycle set buffer register to the cycle set register at the crest and trough of the TCNT_4 count.* ²

- Notes:
1. Data is transferred from the cycle set buffer register to the cycle set register when the crest of the TCNT_4 count is reached in complementary PWM mode, when compare match occurs between TCNT_3 and TGRA_3 in reset-synchronized PWM mode, or when compare match occurs between TCNT_4 and TGRA_4 in PWM mode 1 or normal operation mode.
 2. These settings are prohibited when complementary PWM mode is not selected.

10.3.11 Timer A/D Converter Start Request Cycle Set Registers (TADCORA_4 and TADCORB_4)

TADCORA_4 and TADCORB_4 are 16-bit readable/writable registers. When the TCNT_4 count reaches the value in TADCORA_4 or TADCORB_4, a corresponding A/D converter start request will be issued.

TADCORA_4 and TADCORB_4 are initialized to H'FFFF.

Bit:	15	14	13	12	11	10	9	8	7	6	5	4	3	2	1	0
Initial value:	1	1	1	1	1	1	1	1	1	1	1	1	1	1	1	1
R/W:	R/W	R/W	R/W	R/W	R/W	R/W	R/W	R/W	R/W	R/W	R/W	R/W	R/W	R/W	R/W	R/W

Note: TADCORA_4 and TADCORB_4 must not be accessed in eight bits; they should always be accessed in 16 bits.

10.3.12 Timer A/D Converter Start Request Cycle Set Buffer Registers (TADCOBRA_4 and TADCOBRB_4)

TADCOBRA_4 and TADCOBRB_4 are 16-bit readable/writable registers. When the crest or trough of the TCNT_4 count is reached, these register values are transferred to TADCORA_4 and TADCORB_4, respectively.

TADCOBRA_4 and TADCOBRB_4 are initialized to H'FFFF.

Bit:	15	14	13	12	11	10	9	8	7	6	5	4	3	2	1	0
Initial value:	1	1	1	1	1	1	1	1	1	1	1	1	1	1	1	1
R/W:	R/W	R/W	R/W	R/W	R/W	R/W	R/W	R/W	R/W	R/W	R/W	R/W	R/W	R/W	R/W	R/W

Note: TADCOBRA_4 and TADCOBRB_4 must not be accessed in eight bits; they should always be accessed in 16 bits.

10.3.13 Timer Counter (TCNT)

The TCNT counters are 16-bit readable/writable counters. The MTU2 has eight TCNT counters, one each for channels 0 to 4 and three (TCNTU_5, TCNTV_5, and TCNTW_5) for channel 5.

The TCNT counters are initialized to H'0000 by a reset.

Bit:	15	14	13	12	11	10	9	8	7	6	5	4	3	2	1	0
Initial value:	0	0	0	0	0	0	0	0	0	0	0	0	0	0	0	0
R/W:	R/W	R/W	R/W	R/W	R/W	R/W	R/W	R/W	R/W	R/W	R/W	R/W	R/W	R/W	R/W	R/W

Note: The TCNT counters must not be accessed in eight bits; they should always be accessed in 16 bits.

10.3.14 Timer General Register (TGR)

The TGR registers are 16-bit readable/writable registers. The MTU2 has 21 TGR registers, six for channel 0, two each for channels 1 and 2, four each for channels 3 and 4, and three for channel 5.

TGRA, TGRB, TGRC, and TGRD function as either output compare or input capture registers. TGRC and TGRD for channels 0, 3, and 4 can also be designated for operation as buffer registers. TGR buffer register combinations are TGRA and TGRC, and TGRB and TGRD.

TGRE_0 and TGRF_0 function as compare registers. When the TCNT_0 count matches the TGRE_0 value, an A/D converter start request can be issued. TGRF can also be designated for operation as a buffer register. TGR buffer register combination is TGRE and TGRF.

TGRU_5, TGRV_5, and TGRW_5 function as compare match, input capture, or external pulse width measurement registers.

Bit:	15	14	13	12	11	10	9	8	7	6	5	4	3	2	1	0
Initial value:	1	1	1	1	1	1	1	1	1	1	1	1	1	1	1	1
R/W:	R/W	R/W	R/W	R/W	R/W	R/W	R/W	R/W	R/W	R/W	R/W	R/W	R/W	R/W	R/W	R/W

Note: The TGR registers must not be accessed in eight bits; they should always be accessed in 16 bits. TGR registers are initialized to H'FFFF.

10.3.15 Timer Start Register (TSTR)

TSTR is an 8-bit readable/writable register that selects operation/stoppage of TCNT for channels 0 to 4.

TSTR_5 is an 8-bit readable/writable register that selects operation/stoppage of TCNTU_5, TCNTV_5, and TCNTW_5 for channel 5.

When setting the operating mode in TMDR or setting the count clock in TCR, first stop the TCNT counter.

- TSTR

Bit:	7	6	5	4	3	2	1	0
	CST4	CST3	-	-	-	CST2	CST1	CST0
Initial value:	0	0	0	0	0	0	0	0
R/W:	R/W	R/W	R	R	R	R/W	R/W	R/W

Bit	Bit Name	Initial Value	R/W	Description
7	CST4	0	R/W	Counter Start 4 and 3
6	CST3	0	R/W	<p>These bits select operation or stoppage for TCNT.</p> <p>If 0 is written to the CST bit during operation with the TIOC pin designated for output, the counter stops but the TIOC pin output compare output level is retained. If TIOR is written to when the CST bit is cleared to 0, the pin output level will be changed to the set initial output value.</p> <p>0: TCNT_4 and TCNT_3 count operation is stopped</p> <p>1: TCNT_4 and TCNT_3 performs count operation</p>
5 to 3	—	All 0	R	<p>Reserved</p> <p>These bits are always read as 0. The write value should always be 0.</p>

Bit	Bit Name	Initial Value	R/W	Description
2	CST2	0	R/W	Counter Start 2 to 0
1	CST1	0	R/W	These bits select operation or stoppage for TCNT.
0	CST0	0	R/W	If 0 is written to the CST bit during operation with the TIOC pin designated for output, the counter stops but the TIOC pin output compare output level is retained. If TIOR is written to when the CST bit is cleared to 0, the pin output level will be changed to the set initial output value. 0: TCNT_2 to TCNT_0 count operation is stopped 1: TCNT_2 to TCNT_0 performs count operation

- TSTR_5

Bit :	7	6	5	4	3	2	1	0
	-	-	-	-	-	CSTU5	CSTV5	CSTW5
Initial value:	0	0	0	0	0	0	0	0
R/W:	R	R	R	R	R	R/W	R/W	R/W

Bit	Bit Name	Initial Value	R/W	Description
7 to 3	—	All 0	R	Reserved These bits are always read as 0. The write value should always be 0.
2	CSTU5	0	R/W	Counter Start U5 Selects operation or stoppage for TCNTU_5. 0: TCNTU_5 count operation is stopped 1: TCNTU_5 performs count operation
1	CSTV5	0	R/W	Counter Start V5 Selects operation or stoppage for TCNTV_5. 0: TCNTV_5 count operation is stopped 1: TCNTV_5 performs count operation
0	CSTW5	0	R/W	Counter Start W5 Selects operation or stoppage for TCNTW_5. 0: TCNTW_5 count operation is stopped 1: TCNTW_5 performs count operation

10.3.16 Timer Synchronous Register (TSYR)

TSYR is an 8-bit readable/writable register that selects independent operation or synchronous operation for the channel 0 to 4 TCNT counters. A channel performs synchronous operation when the corresponding bit in TSYR is set to 1.

Bit:	7	6	5	4	3	2	1	0
	SYNC4	SYNC3	-	-	-	SYNC2	SYNC1	SYNC0
Initial value:	0	0	0	0	0	0	0	0
R/W:	R/W	R/W	R	R	R	R/W	R/W	R/W

Bit	Bit Name	Initial Value	R/W	Description
7	SYNC4	0	R/W	Timer Synchronous operation 4 and 3
6	SYNC3	0	R/W	<p>These bits are used to select whether operation is independent of or synchronized with other channels. When synchronous operation is selected, the TCNT synchronous presetting of multiple channels, and synchronous clearing by counter clearing on another channel, are possible.</p> <p>To set synchronous operation, the SYNC bits for at least two channels must be set to 1. To set synchronous clearing, in addition to the SYNC bit, the TCNT clearing source must also be set by means of bits CCLR0 to CCLR2 in TCR.</p> <p>0: TCNT_4 and TCNT_3 operate independently (TCNT presetting/clearing is unrelated to other channels)</p> <p>1: TCNT_4 and TCNT_3 performs synchronous operation TCNT synchronous presetting/synchronous clearing is possible</p>
5 to 3	—	All 0	R	<p>Reserved</p> <p>These bits are always read as 0. The write value should always be 0.</p>

Bit	Bit Name	Initial Value	R/W	Description
2	SYNC2	0	R/W	Timer Synchronous operation 2 to 0
1	SYNC1	0	R/W	<p>These bits are used to select whether operation is independent of or synchronized with other channels. When synchronous operation is selected, the TCNT synchronous presetting of multiple channels, and synchronous clearing by counter clearing on another channel, are possible.</p> <p>To set synchronous operation, the SYNC bits for at least two channels must be set to 1. To set synchronous clearing, in addition to the SYNC bit, the TCNT clearing source must also be set by means of bits CCLR0 to CCLR2 in TCR.</p> <p>0: TCNT_2 to TCNT_0 operates independently (TCNT presetting /clearing is unrelated to other channels)</p> <p>1: TCNT_2 to TCNT_0 performs synchronous operation TCNT synchronous presetting/synchronous clearing is possible</p>
0	SYNC0	0	R/W	

10.3.17 Timer Counter Synchronous Start Register (TCSYSTR)

TCSYSTR is an 8-bit readable/writable register that specifies synchronous start of the MTU2 and MTU2S counters. Note that the MTU2S does not have TCSYSTR.

Bit:	7	6	5	4	3	2	1	0
	SCH0	SCH1	SCH2	SCH3	SCH4	-	SCH3S	SCH4S
Initial value:	0	0	0	0	0	0	0	0
R/W:	R/(W)*	R/(W)*	R/(W)*	R/(W)*	R/(W)*	R	R/(W)*	R/(W)*

Note: * Only 1 can be written to set the register.

Bit	Bit Name	Initial Value	R/W	Description
7	SCH0	0	R/(W)*	<p>Synchronous Start</p> <p>Controls synchronous start of TCNT_0 in the MTU2.</p> <p>0: Does not specify synchronous start for TCNT_0 in the MTU2</p> <p>1: Specifies synchronous start for TCNT_0 in the MTU2 [Clearing condition]</p> <ul style="list-style-type: none"> • When 1 is set to the CST0 bit of TSTR in MTU2 while SCH0 = 1
6	SCH1	0	R/(W)*	<p>Synchronous Start</p> <p>Controls synchronous start of TCNT_1 in the MTU2.</p> <p>0: Does not specify synchronous start for TCNT_1 in the MTU2</p> <p>1: Specifies synchronous start for TCNT_1 in the MTU2 [Clearing condition]</p> <ul style="list-style-type: none"> • When 1 is set to the CST1 bit of TSTR in MTU2 while SCH1 = 1

Bit	Bit Name	Initial Value	R/W	Description
5	SCH2	0	R/(W)*	<p>Synchronous Start</p> <p>Controls synchronous start of TCNT_2 in the MTU2.</p> <p>0: Does not specify synchronous start for TCNT_2 in the MTU2</p> <p>1: Specifies synchronous start for TCNT_2 in the MTU2 [Clearing condition]</p> <ul style="list-style-type: none"> When 1 is set to the CST2 bit of TSTR in MTU2 while SCH2 = 1
4	SCH3	0	R/(W)*	<p>Synchronous Start</p> <p>Controls synchronous start of TCNT_3 in the MTU2.</p> <p>0: Does not specify synchronous start for TCNT_3 in the MTU2</p> <p>1: Specifies synchronous start for TCNT_3 in the MTU2 [Clearing condition]</p> <ul style="list-style-type: none"> When 1 is set to the CST3 bit of TSTR in MTU2 while SCH3 = 1
3	SCH4	0	R/(W)*	<p>Synchronous Start</p> <p>Controls synchronous start of TCNT_4 in the MTU2.</p> <p>0: Does not specify synchronous start for TCNT_4 in the MTU2</p> <p>1: Specifies synchronous start for TCNT_4 in the MTU2 [Clearing condition]</p> <ul style="list-style-type: none"> When 1 is set to the CST4 bit of TSTR in MTU2 while SCH4 = 1
2	—	0	R	<p>Reserved</p> <p>This bit is always read as 0. The write value should always be 0.</p>

Bit	Bit Name	Initial Value	R/W	Description
1	SCH3S	0	R/(W)*	<p>Synchronous Start</p> <p>Controls synchronous start of TCNT_3S in the MTU2S.</p> <p>0: Does not specify synchronous start for TCNT_3S in the MTU2S</p> <p>1: Specifies synchronous start for TCNT_3S in the MTU2S</p> <p>[Clearing condition]</p> <ul style="list-style-type: none"> When 1 is set to the CST3 bit of TSTRS in MTU2S while SCH3S = 1
0	SCH4S	0	R/(W)*	<p>Synchronous Start</p> <p>Controls synchronous start of TCNT_4S in the MTU2S.</p> <p>0: Does not specify synchronous start for TCNT_4S in the MTU2S</p> <p>1: Specifies synchronous start for TCNT_4S in the MTU2S</p> <p>[Clearing condition]</p> <ul style="list-style-type: none"> When 1 is set to the CST4 bit of TSTRS in MTU2S while SCH4S = 1

Note: * Only 1 can be written to set the register.

10.3.18 Timer Read/Write Enable Register (TRWER)

TRWER is an 8-bit readable/writable register that enables or disables access to the registers and counters which have write-protection capability against accidental modification in channels 3 and 4.

Bit:	7	6	5	4	3	2	1	0
	-	-	-	-	-	-	-	RWE
Initial value:	0	0	0	0	0	0	0	1
R/W:	R	R	R	R	R	R	R	R/W

Bit	Bit Name	Initial Value	R/W	Description
7 to 1	—	All 0	R	Reserved These bits are always read as 0. The write value should always be 0.
0	RWE	1	R/W	Read/Write Enable Enables or disables access to the registers which have write-protection capability against accidental modification. 0: Disables read/write access to the registers 1: Enables read/write access to the registers [Clearing condition] <ul style="list-style-type: none"> • When 0 is written to the RWE bit after reading RWE = 1

- Registers and counters having write-protection capability against accidental modification
22 registers: TCR_3, TCR_4, TMDR_3, TMDR_4, TIORH_3, TIORH_4, TIORL_3, TIORL_4, TIER_3, TIER_4, TGRA_3, TGRA_4, TGRB_3, TGRB_4, TOER, TOCR1, TOCR2, TGCR, TCDR, TDDR, TCNT_3, and TCNT4.

10.3.19 Timer Output Master Enable Register (TOER)

TOER is an 8-bit readable/writable register that enables/disables output settings for output pins TIOC4D, TIOC4C, TIOC3D, TIOC4B, TIOC4A, and TIOC3B. These pins do not output correctly if the TOER bits have not been set. Set TOER of CH3 and CH4 prior to setting TIOR of CH3 and CH4.

Bit:	7	6	5	4	3	2	1	0
	-	-	OE4D	OE4C	OE3D	OE4B	OE4A	OE3B
Initial value:	1	1	0	0	0	0	0	0
R/W:	R	R	R/W	R/W	R/W	R/W	R/W	R/W

Bit	Bit Name	Initial Value	R/W	Description
7, 6	—	All 1	R	Reserved These bits are always read as 1. The write value should always be 1.
5	OE4D	0	R/W	Master Enable TIOC4D This bit enables/disables the TIOC4D pin MTU2 output. 0: MTU2 output is disabled (inactive level)* 1: MTU2 output is enabled
4	OE4C	0	R/W	Master Enable TIOC4C This bit enables/disables the TIOC4C pin MTU2 output. 0: MTU2 output is disabled (inactive level)* 1: MTU2 output is enabled
3	OE3D	0	R/W	Master Enable TIOC3D This bit enables/disables the TIOC3D pin MTU2 output. 0: MTU2 output is disabled (inactive level)* 1: MTU2 output is enabled
2	OE4B	0	R/W	Master Enable TIOC4B This bit enables/disables the TIOC4B pin MTU2 output. 0: MTU2 output is disabled (inactive level)* 1: MTU2 output is enabled
1	OE4A	0	R/W	Master Enable TIOC4A This bit enables/disables the TIOC4A pin MTU2 output. 0: MTU2 output is disabled (inactive level)* 1: MTU2 output is enabled

Bit	Bit Name	Initial Value	R/W	Description
0	OE3B	0	R/W	Master Enable TIOC3B This bit enables/disables the TIOC3B pin MTU2 output. 0: MTU2 output is disabled (inactive level)* 1: MTU2 output is enabled

Note: * The inactive level is determined by the settings in timer output control registers 1 and 2 (TOCR1 and TOCR2). For details, refer to section 10.3.20, Timer Output Control Register 1 (TOCR1), and section 10.3.21, Timer Output Control Register 2 (TOCR2). Set these bits to 1 to enable MTU2 output in other than complementary PWM or reset-synchronized PWM mode. When these bits are set to 0, low level is output.

10.3.20 Timer Output Control Register 1 (TOCR1)

TOCR1 is an 8-bit readable/writable register that enables/disables PWM synchronized toggle output in complementary PWM mode/reset synchronized PWM mode, and controls output level inversion of PWM output.

Bit:	7	6	5	4	3	2	1	0
	-	PSYE	-	-	TOCL	TOCS	OLSN	OLSP
Initial value:	0	0	0	0	0	0	0	0
R/W:	R	R/W	R	R	R/(W)*	R/W	R/W	R/W

Note: * This bit can be set to 1 only once after a power-on reset. After 1 is written, 0 cannot be written to the bit.

Bit	Bit Name	Initial value	R/W	Description
7	—	0	R	Reserved This bit is always read as 0. The write value should always be 0.
6	PSYE	0	R/W	PWM Synchronous Output Enable This bit selects the enable/disable of toggle output synchronized with the PWM period. 0: Toggle output is disabled 1: Toggle output is enabled
5, 4	—	All 0	R	Reserved These bits are always read as 0. The write value should always be 0.

Bit	Bit Name	Initial Value	R/W	Description
3	TOCL	0	R/(W)*	<p>TOC Register Write Protection*¹</p> <p>This bit selects the enable/disable of write access to the TOCS, OLSN, and OLSP bits in TOCR1.</p> <p>0: Write access to the TOCS, OLSN, and OLSP bits is enabled</p> <p>1: Write access to the TOCS, OLSN, and OLSP bits is disabled</p>
2	TOCS	0	R/W	<p>TOC Select</p> <p>This bit selects either the TOCR1 or TOCR2 setting to be used for the output level in complementary PWM mode and reset-synchronized PWM mode.</p> <p>0: TOCR1 setting is selected</p> <p>1: TOCR2 setting is selected</p>
1	OLSN	0	R/W	<p>Output Level Select N*²</p> <p>This bit selects the reverse phase output level in reset-synchronized PWM mode/complementary PWM mode. See table 10.30.</p>
0	OLSP	0	R/W	<p>Output Level Select P*²</p> <p>This bit selects the positive phase output level in reset-synchronized PWM mode/complementary PWM mode. See table 10.31.</p>

Notes: 1. Setting the TOCL bit to 1 prevents accidental modification when the CPU goes out of control.

2. Clearing the TOCS0 bit to 0 makes this bit setting valid.

Table 10.30 Output Level Select Function

Bit 1	Function			
	OLSN	Initial Output	Active Level	Compare Match Output
Up Count				Down Count
0	High level	Low level	High level	Low level
1	Low level	High level	Low level	High level

Note: The reverse phase waveform initial output value changes to active level after elapse of the dead time after count start.

Table 10.31 Output Level Select Function

Bit 0	Function			
	OLSP	Initial Output	Active Level	Compare Match Output
			Up Count	Down Count
0	High level	Low level	Low level	High level
1	Low level	High level	High level	Low level

Figure 10.2 shows an example of complementary PWM mode output (1 phase) when OLSN = 1, OLSP = 1.

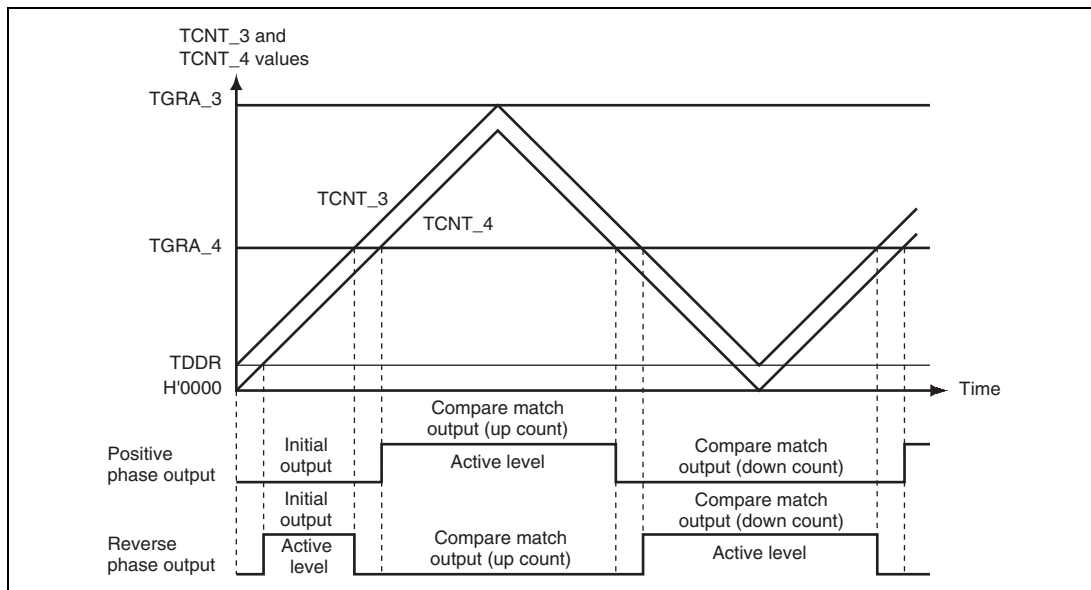
**Figure 10.2 Complementary PWM Mode Output Level Example**

10.3.21 Timer Output Control Register 2 (TOCR2)

TOCR2 is an 8-bit readable/writable register that controls output level inversion of PWM output in complementary PWM mode and reset-synchronized PWM mode.

Bit:	7	6	5	4	3	2	1	0
	BF[1:0]	OLS3N	OLS3P	OLS2N	OLS2P	OLS1N	OLS1P	
Initial value:	0	0	0	0	0	0	0	0
R/W:	R/W	R/W	R/W	R/W	R/W	R/W	R/W	R/W

Bit	Bit Name	Initial value	R/W	Description
7, 6	BF[1:0]	00	R/W	TOLBR Buffer Transfer Timing Select These bits select the timing for transferring data from TOLBR to TOCR2. For details, see table 10.32.
5	OLS3N	0	R/W	Output Level Select 3N* This bit selects the output level on TIOC4D in reset-synchronized PWM mode/complementary PWM mode. See table 10.33.
4	OLS3P	0	R/W	Output Level Select 3P* This bit selects the output level on TIOC4B in reset-synchronized PWM mode/complementary PWM mode. See table 10.34.
3	OLS2N	0	R/W	Output Level Select 2N* This bit selects the output level on TIOC4C in reset-synchronized PWM mode/complementary PWM mode. See table 10.35.
2	OLS2P	0	R/W	Output Level Select 2P* This bit selects the output level on TIOC4A in reset-synchronized PWM mode/complementary PWM mode. See table 10.36.
1	OLS1N	0	R/W	Output Level Select 1N* This bit selects the output level on TIOC3D in reset-synchronized PWM mode/complementary PWM mode. See table 10.37.

Bit	Bit Name	Initial value	R/W	Description
0	OLS1P	0	R/W	Output Level Select 1P* This bit selects the output level on TIOC3B in reset-synchronized PWM mode/complementary PWM mode. See table 10.38.

Note: * Setting the TOCS bit in TOCR1 to 1 makes this bit setting valid.

Table 10.32 Setting of Bits BF1 and BF0

Bit 7	Bit 6	Description	
BF1	BF0	Complementary PWM Mode	Reset-Synchronized PWM Mode
0	0	Does not transfer data from the buffer register (TOLBR) to TOCR2.	Does not transfer data from the buffer register (TOLBR) to TOCR2.
0	1	Transfers data from the buffer register (TOLBR) to TOCR2 at the crest of the TCNT_4 count.	Transfers data from the buffer register (TOLBR) to TOCR2 when TCNT_3/TCNT_4 is cleared
1	0	Transfers data from the buffer register (TOLBR) to TOCR2 at the trough of the TCNT_4 count.	Setting prohibited
1	1	Transfers data from the buffer register (TOLBR) to TOCR2 at the crest and trough of the TCNT_4 count.	Setting prohibited

Table 10.33 TIOC4D Output Level Select Function

Bit 5	Function			
OLS3N	Initial Output	Active Level	Compare Match Output	
			Up Count	Down Count
0	High level	Low level	High level	Low level
1	Low level	High level	Low level	High level

Note: The reverse phase waveform initial output value changes to the active level after elapse of the dead time after count start.

Table 10.34 TIOC4B Output Level Select Function

Bit 4		Function		
OLS3P	Initial Output	Active Level	Compare Match Output	
			Up Count	Down Count
0	High level	Low level	Low level	High level
1	Low level	High level	High level	Low level

Table 10.35 TIOC4C Output Level Select Function

Bit 3		Function		
OLS2N	Initial Output	Active Level	Compare Match Output	
			Up Count	Down Count
0	High level	Low level	High level	Low level
1	Low level	High level	Low level	High level

Note: The reverse phase waveform initial output value changes to the active level after elapse of the dead time after count start.

Table 10.36 TIOC4A Output Level Select Function

Bit 2		Function		
OLS2P	Initial Output	Active Level	Compare Match Output	
			Up Count	Down Count
0	High level	Low level	Low level	High level
1	Low level	High level	High level	Low level

Table 10.37 TIOC3D Output Level Select Function

Bit 1		Function		
OLS1N	Initial Output	Active Level	Compare Match Output	
			Up Count	Down Count
0	High level	Low level	High level	Low level
1	Low level	High level	Low level	High level

Note: The reverse phase waveform initial output value changes to the active level after elapse of the dead time after count start.

Table 10.38 TIOC4B Output Level Select Function

Bit 0	Function			
	OLS1P	Initial Output	Active Level	Compare Match Output
Up Count				Down Count
0	High level	Low level	Low level	High level
1	Low level	High level	High level	Low level

10.3.22 Timer Output Level Buffer Register (TOLBR)

TOLBR is an 8-bit readable/writable register that functions as a buffer for TOCR2 and specifies the PWM output level in complementary PWM mode and reset-synchronized PWM mode.

Bit:	7	6	5	4	3	2	1	0
	-	-	OLS3N	OLS3P	OLS2N	OLS2P	OLS1N	OLS1P
Initial value:	0	0	0	0	0	0	0	0
R/W:	R	R	R/W	R/W	R/W	R/W	R/W	R/W

Bit	Bit Name	Initial value	R/W	Description
7, 6	—	All 0	R	Reserved These bits are always read as 0. The write value should always be 0.
5	OLS3N	0	R/W	Specifies the buffer value to be transferred to the OLS3N bit in TOCR2.
4	OLS3P	0	R/W	Specifies the buffer value to be transferred to the OLS3P bit in TOCR2.
3	OLS2N	0	R/W	Specifies the buffer value to be transferred to the OLS2N bit in TOCR2.
2	OLS2P	0	R/W	Specifies the buffer value to be transferred to the OLS2P bit in TOCR2.
1	OLS1N	0	R/W	Specifies the buffer value to be transferred to the OLS1N bit in TOCR2.
0	OLS1P	0	R/W	Specifies the buffer value to be transferred to the OLS1P bit in TOCR2.

Figure 10.3 shows an example of the PWM output level setting procedure in buffer operation.

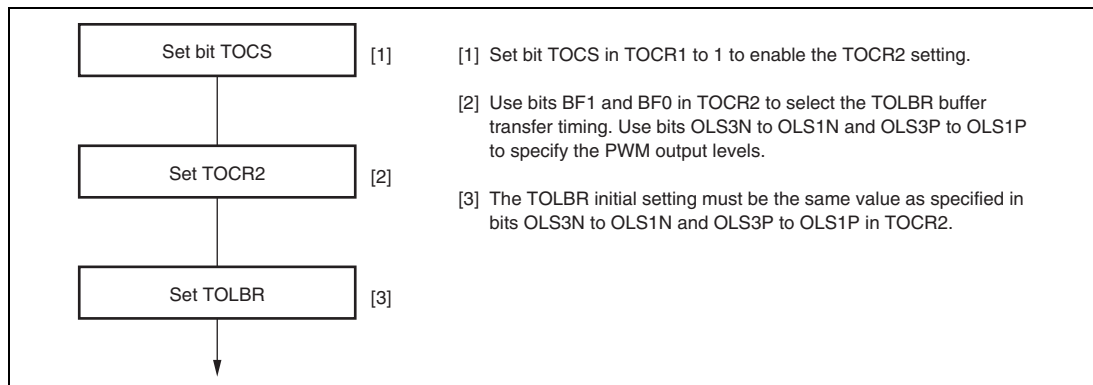

Figure 10.3 PWM Output Level Setting Procedure in Buffer Operation

10.3.23 Timer Gate Control Register (TGCR)

TGCR is an 8-bit readable/writable register that controls the waveform output necessary for brushless DC motor control in reset-synchronized PWM mode/complementary PWM mode. These register settings are ineffective for anything other than complementary PWM mode/reset-synchronized PWM mode.

Bit:	7	6	5	4	3	2	1	0
	-	BDC	N	P	FB*	WF	VF	UF
Initial value:	1	0	0	0	0	0	0	0
R/W:	R	R/W	R/W	R/W	R/W	R/W	R/W	R/W

Bit	Bit Name	Initial value	R/W	Description
7	—	1	R	Reserved This bit is always read as 1. The write value should always be 1.
6	BDC	0	R/W	Brushless DC Motor This bit selects whether to make the functions of this register (TGCR) effective or ineffective. 0: Ordinary output 1: Functions of this register are made effective

Bit	Bit Name	Initial value	R/W	Description
5	N	0	R/W	<p>Reverse Phase Output (N) Control</p> <p>This bit selects whether the level output or the reset-synchronized PWM/complementary PWM output while the reverse pins (TIOC3D, TIOC4C, and TIOC4D) are output.</p> <p>0: Level output 1: Reset synchronized PWM/complementary PWM output</p>
4	P	0	R/W	<p>Positive Phase Output (P) Control</p> <p>This bit selects whether the level output or the reset-synchronized PWM/complementary PWM output while the positive pin (TIOC3B, TIOC4A, and TIOC4B) are output.</p> <p>0: Level output 1: Reset synchronized PWM/complementary PWM output</p>
3	FB*	0	R/W	<p>External Feedback Signal Enable</p> <p>This bit selects whether the switching of the output of the positive/reverse phase is carried out automatically with the MTU2/channel 0 TGRA, TGRB, TGRC input capture signals or by writing 0 or 1 to bits 2 to 0 in TGCR.</p> <p>0: Output switching is external input (Input sources are channel 0 TGRA, TGRB, TGRC input capture signal) 1: Output switching is carried out by software (TGCR's UF, VF, WF settings).</p>
2	WF	0	R/W	Output Phase Switch 2 to 0
1	VF	0	R/W	These bits set the positive phase/negative phase output phase on or off state. The setting of these bits is valid only when the FB bit in this register is set to 1. In this case, the setting of bits 2 to 0 is a substitute for external input. See table 10.39.
0	UF	0	R/W	

Note: * When the MTU2S is used to set the BDC bit to 1, do not set the FB bit to 0.

Table 10.39 Output level Select Function

Bit 2	Bit 1	Bit 0	Function					
			TIOC3B	TIOC4A	TIOC4B	TIOC3D	TIOC4C	TIOC4D
WF	VF	UF	U Phase	V Phase	W Phase	U Phase	V Phase	W Phase
0	0	0	OFF	OFF	OFF	OFF	OFF	OFF
		1	ON	OFF	OFF	OFF	OFF	ON
	1	0	OFF	ON	OFF	ON	OFF	OFF
		1	OFF	ON	OFF	OFF	OFF	ON
1	0	0	OFF	OFF	ON	OFF	ON	OFF
		1	ON	OFF	OFF	OFF	ON	OFF
	1	0	OFF	OFF	ON	ON	OFF	OFF
		1	OFF	OFF	OFF	OFF	OFF	OFF

10.3.24 Timer Subcounter (TCNTS)

TCNTS is a 16-bit read-only counter that is used only in complementary PWM mode.

The initial value of TCNTS is H'0000.

Bit:	15	14	13	12	11	10	9	8	7	6	5	4	3	2	1	0
Initial value:	0	0	0	0	0	0	0	0	0	0	0	0	0	0	0	0
R/W:	R	R	R	R	R	R	R	R	R	R	R	R	R	R	R	R

Note: Accessing the TCNTS in 8-bit units is prohibited. Always access in 16-bit units.

10.3.25 Timer Dead Time Data Register (TDDR)

TDDR is a 16-bit register, used only in complementary PWM mode, that specifies the TCNT_3 and TCNT_4 counter offset values. In complementary PWM mode, when the TCNT_3 and TCNT_4 counters are cleared and then restarted, the TDDR register value is loaded into the TCNT_3 counter and the count operation starts.

The initial value of TDDR is H'FFFF.

Bit:	15	14	13	12	11	10	9	8	7	6	5	4	3	2	1	0
Initial value:	1	1	1	1	1	1	1	1	1	1	1	1	1	1	1	1
R/W:	R/W	R/W	R/W	R/W	R/W	R/W	R/W	R/W	R/W	R/W	R/W	R/W	R/W	R/W	R/W	R/W

Note: Accessing the TDDR in 8-bit units is prohibited. Always access in 16-bit units.

10.3.26 Timer Cycle Data Register (TCDR)

TCDR is a 16-bit register used only in complementary PWM mode. Set half the PWM carrier sync value as the TCCR register value. This register is constantly compared with the TCNTS counter in complementary PWM mode, and when a match occurs, the TCNTS counter switches direction (decrement to increment).

The initial value of TCCR is H'FFFF.

Bit:	15	14	13	12	11	10	9	8	7	6	5	4	3	2	1	0
Initial value:	1	1	1	1	1	1	1	1	1	1	1	1	1	1	1	1
R/W:	R/W	R/W	R/W	R/W	R/W	R/W	R/W	R/W	R/W	R/W	R/W	R/W	R/W	R/W	R/W	R/W

Note: Accessing the TCCR in 8-bit units is prohibited. Always access in 16-bit units.

10.3.27 Timer Cycle Buffer Register (TCBR)

TCBR is a 16-bit register used only in complementary PWM mode. It functions as a buffer register for the TCDR register. The TCBR register values are transferred to the TCDR register with the transfer timing set in the TMDR register.

The initial value of TCBR is H'FFFF.

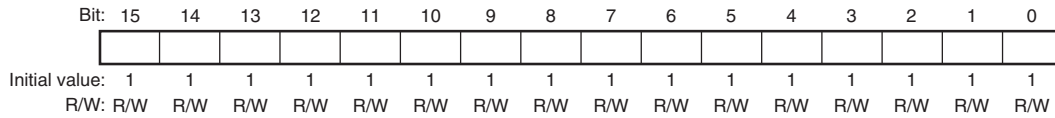

Note: Accessing the TCBR in 8-bit units is prohibited. Always access in 16-bit units.

10.3.28 Timer Interrupt Skipping Set Register (TITCR)

TITCR is an 8-bit readable/writable register that enables or disables interrupt skipping and specifies the interrupt skipping count. The MTU2 has one TITCR.

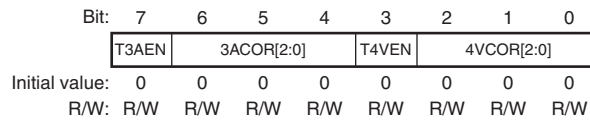

Bit	Bit Name	Initial value	R/W	Description
7	T3AEN	0	R/W	T3AEN Enables or disables TGIA_3 interrupt skipping. 0: TGIA_3 interrupt skipping disabled 1: TGIA_3 interrupt skipping enabled
6 to 4	3ACOR[2:0]	000	R/W	These bits specify the TGIA_3 interrupt skipping count within the range from 0 to 7.* For details, see table 10.40.
3	T4VEN	0	R/W	T4VEN Enables or disables TCIV_4 interrupt skipping. 0: TCIV_4 interrupt skipping disabled 1: TCIV_4 interrupt skipping enabled

Bit	Bit Name	Initial value	R/W	Description
2 to 0	4VCOR[2:0]	000	R/W	These bits specify the TCIV_4 interrupt skipping count within the range from 0 to 7.* For details, see table 10.41.

Note: * When 0 is specified for the interrupt skipping count, no interrupt skipping will be performed. Before changing the interrupt skipping count, be sure to clear the T3AEN and T4VEN bits to 0 to clear the skipping counter (TITCNT).

Table 10.40 Setting of Interrupt Skipping Count by Bits 3ACOR2 to 3ACOR0

Bit 6	Bit 5	Bit 4	Description
3ACOR2	3ACOR1	3ACOR0	
0	0	0	Does not skip TGIA_3 interrupts.
0	0	1	Sets the TGIA_3 interrupt skipping count to 1.
0	1	0	Sets the TGIA_3 interrupt skipping count to 2.
0	1	1	Sets the TGIA_3 interrupt skipping count to 3.
1	0	0	Sets the TGIA_3 interrupt skipping count to 4.
1	0	1	Sets the TGIA_3 interrupt skipping count to 5.
1	1	0	Sets the TGIA_3 interrupt skipping count to 6.
1	1	1	Sets the TGIA_3 interrupt skipping count to 7.

Table 10.41 Setting of Interrupt Skipping Count by Bits 4VCOR2 to 4VCOR0

Bit 2	Bit 1	Bit 0	Description
4VCOR2	4VCOR1	4VCOR0	
0	0	0	Does not skip TCIV_4 interrupts.
0	0	1	Sets the TCIV_4 interrupt skipping count to 1.
0	1	0	Sets the TCIV_4 interrupt skipping count to 2.
0	1	1	Sets the TCIV_4 interrupt skipping count to 3.
1	0	0	Sets the TCIV_4 interrupt skipping count to 4.
1	0	1	Sets the TCIV_4 interrupt skipping count to 5.
1	1	0	Sets the TCIV_4 interrupt skipping count to 6.
1	1	1	Sets the TCIV_4 interrupt skipping count to 7.

10.3.29 Timer Interrupt Skipping Counter (TITCNT)

TITCNT is an 8-bit readable/writable counter. The MTU2 has one TITCNT. TITCNT retains its value even after stopping the count operation of TCNT_3 and TCNT_4.

Bit:	7	6	5	4	3	2	1	0
	-	3ACNT[2:0]			-	4VCNT[2:0]		
Initial value:	0	0	0	0	0	0	0	0
R/W:	R	R	R	R	R	R	R	R

Bit	Bit Name	Initial Value	R/W	Description
7	—	0	R	Reserved This bit is always read as 0.
6 to 4	3ACNT[2:0]	000	R	TGIA_3 Interrupt Counter While the T3AEN bit in TITCR is set to 1, the count in these bits is incremented every time a TGIA_3 interrupt occurs. [Clearing conditions] <ul style="list-style-type: none"> • When the 3ACNT2 to 3ACNT0 value in TITCNT matches the 3ACOR2 to 3ACOR0 value in TITCR • When the T3AEN bit in TITCR is cleared to 0 • When the 3ACOR2 to 3ACOR0 bits in TITCR are cleared to 0
3	—	0	R	Reserved This bit is always read as 0.
2 to 0	4VCNT[2:0]	000	R	TCIV_4 Interrupt Counter While the T4VEN bit in TITCR is set to 1, the count in these bits is incremented every time a TCIV_4 interrupt occurs. [Clearing conditions] <ul style="list-style-type: none"> • When the 4VCNT2 to 4VCNT0 value in TITCNT matches the 4VCOR2 to 4VCOR2 value in TITCR • When the T4VEN bit in TITCR is cleared to 0 • When the 4VCOR2 to 4VCOR2 bits in TITCR are cleared to 0

Note: To clear the TITCNT, clear the T3AEN and T4VEN bits in TITCR to 0.

10.3.30 Timer Buffer Transfer Set Register (TBTER)

TBTER is an 8-bit readable/writable register that enables or disables transfer from the buffer registers* used in complementary PWM mode to the temporary registers and specifies whether to link the transfer with interrupt skipping operation. The MTU2 has one TBTER.

Bit:	7	6	5	4	3	2	1	0
	-	-	-	-	-	-	BTE[1:0]	
Initial value:	0	0	0	0	0	0	0	0
R/W:	R	R	R	R	R	R	R/W	R/W

Bit	Bit Name	Initial Value	R/W	Description
7 to 2	—	All 0	R	Reserved These bits are always read as 0. The write value should always be 0.
1, 0	BTE[1:0]	00	R/W	These bits enable or disable transfer from the buffer registers* used in complementary PWM mode to the temporary registers and specify whether to link the transfer with interrupt skipping operation. For details, see table 10.42.

Note: * Applicable buffer registers:
TGRC_3, TGRD_3, TGRC_4, TGRD_4, and TCBR

Table 10.42 Setting of Bits BTE1 and BTE0

Bit 1	Bit 0	
BTE1	BTE0	Description
0	0	Enables transfer from the buffer registers to the temporary registers* ¹ and does not link the transfer with interrupt skipping operation.
0	1	Disables transfer from the buffer registers to the temporary registers.
1	0	Links transfer from the buffer registers to the temporary registers with interrupt skipping operation.* ²
1	1	Setting prohibited

- Notes: 1. Data is transferred according to the MD3 to MD0 bit setting in TMDR. For details, refer to section 10.4.8, Complementary PWM Mode.
2. When interrupt skipping is disabled (the T3AEN and T4VEN bits are cleared to 0 in the timer interrupt skipping set register (TITCR) or the skipping count set bits (3ACOR and 4VCOR) in TITCR are cleared to 0)), be sure to disable link of buffer transfer with interrupt skipping (clear the BTE1 bit in the timer buffer transfer set register (TBTER) to 0). If link with interrupt skipping is enabled while interrupt skipping is disabled, buffer transfer will not be performed.

10.3.31 Timer Dead Time Enable Register (TDER)

TDER is an 8-bit readable/writable register that controls dead time generation in complementary PWM mode. The MTU2 has one TDER in channel 3. TDER must be modified only while TCNT stops.

Bit:	7	6	5	4	3	2	1	0
	-	-	-	-	-	-	-	TDER
Initial value:	0	0	0	0	0	0	0	1
R/W:	R	R	R	R	R	R	R	R/(W)

Bit	Bit Name	Initial Value	R/W	Description
7 to 1	—	All 0	R	Reserved These bits are always read as 0. The write value should always be 0.
0	TDER	1	R/(W)	Dead Time Enable Specifies whether to generate dead time. 0: Does not generate dead time 1: Generates dead time* [Clearing condition] <ul style="list-style-type: none"> • When 0 is written to TDER after reading TDER = 1

Note: * TDDR must be set to 1 or a larger value.

10.3.32 Timer Waveform Control Register (TWCR)

TWCR is an 8-bit readable/writable register that controls the waveform when synchronous counter clearing occurs in TCNT_3 and TCNT_4 in complementary PWM mode and specifies whether to clear the counters at TGRA_3 compare match. The CCE bit and WRE bit in TWCR must be modified only while TCNT stops.

Bit:	7	6	5	4	3	2	1	0
	CCE	-	-	-	-	-	SCC	WRE
Initial value:	0*	0	0	0	0	0	0	0
R/W:	R/(W)	R	R	R	R	R	R/(W)	R/(W)

Note: * Do not set to 1 when complementary PWM mode is not selected.

Bit	Bit Name	Initial Value	R/W	Description
7	CCE	0*	R/(W)	Compare Match Clear Enable Specifies whether to clear counters at TGRA_3 compare match in complementary PWM mode. 0: Does not clear counters at TGRA_3 compare match 1: Clears counters at TGRA_3 compare match [Setting condition] <ul style="list-style-type: none"> When 1 is written to CCE after reading CCE = 0
6 to 2	—	All 0	R	Reserved These bits are always read as 0. The write value should always be 0.

Bit	Bit Name	Initial Value	R/W	Description
1	SCC	0	R/(W)	<p>Synchronous Clearing Control</p> <p>Specifies whether to clear TCNT_3 and TCNT_4 in the MTU2S when synchronous counter clearing between the MTU2 and MTU2S occurs in complementary PWM mode.</p> <p>When using this control, place the MTU2S in complementary PWM mode.</p> <p>When modifying the SCC bit while the counters are operating, do not modify the CCE or WRE bits.</p> <p>Counter clearing synchronized with the MTU2 is disabled by the SCC bit setting only when synchronous clearing occurs outside the Tb interval at the trough.</p> <p>When synchronous clearing occurs in the Tb interval at the trough including the period immediately after TCNT_3 and TCNT_4 start operation, TCNT_3 and TCNT_4 in the MTU2S are cleared.</p> <p>For the Tb interval at the trough in complementary PWM mode, see figure 10.40.</p> <p>In the MTU2, this bit is reserved. It is always read as 0 and the write value should always be 0.</p> <p>0: Enables clearing of TCNT_3 and TCNT_4 in the MTU2S by MTU2–MTU2S synchronous clearing operation</p> <p>1: Disables clearing of TCNT_3 and TCNT_4 in the MTU2S by MTU2–MTU2S synchronous clearing operation</p> <p>[Setting condition]</p> <ul style="list-style-type: none"> When 1 is written to SCC after reading SCC = 0

Bit	Bit Name	Initial Value	R/W	Description
0	WRE	0	R/(W)	<p>Initial Output Suppression Enable</p> <p>Selects the waveform output when synchronous counter clearing occurs in complementary PWM mode. The initial output is suppressed only when synchronous clearing occurs within the Tb interval at the trough in complementary PWM mode. When synchronous clearing occurs outside this interval, the initial value specified in TOCR is output regardless of the WRE bit setting. The initial value is also output when synchronous clearing occurs in the Tb interval at the trough immediately after TCNT_3 and TCNT_4 start operation.</p> <p>For the Tb interval at the trough in complementary PWM mode, see figure 10.40.</p> <p>0: Outputs the initial value specified in TOCR 1: Suppresses initial output</p> <p>[Setting condition]</p> <ul style="list-style-type: none"> When 1 is written to WRE after reading WRE = 0

Note: * Do not set to 1 when complementary PWM mode is not selected.

10.3.33 Bus Master Interface

The timer counters (TCNT), general registers (TGR), timer subcounter (TCNTS), timer cycle buffer register (TCBR), timer dead time data register (TDDR), timer cycle data register (TCDR), timer A/D converter start request control register (TADCR), timer A/D converter start request cycle set registers (TADCOR), and timer A/D converter start request cycle set buffer registers (TADCOBR) are 16-bit registers. A 16-bit data bus to the bus master enables 16-bit read/writes. 8-bit read/write is not possible. Always access in 16-bit units.

All registers other than the above registers are 8-bit registers. These are connected to the CPU by a 16-bit data bus, so 16-bit read/writes and 8-bit read/writes are both possible.

10.4 Operation

10.4.1 Basic Functions

Each channel has a TCNT and TGR register. TCNT performs up-counting, and is also capable of free-running operation, cycle counting, and external event counting.

Each TGR can be used as an input capture register or output compare register.

Always select MTU2 external pins set function using the pin function controller (PFC).

Counter Operation:

When one of bits CST0 to CST4 in TSTR or bits CSTU5, CSTV5, and CSTW5 in TSTR_5 is set to 1, the TCNT counter for the corresponding channel begins counting. TCNT can operate as a free-running counter, periodic counter, for example.

1. Example of Count Operation Setting Procedure

Figure 10.4 shows an example of the count operation setting procedure.

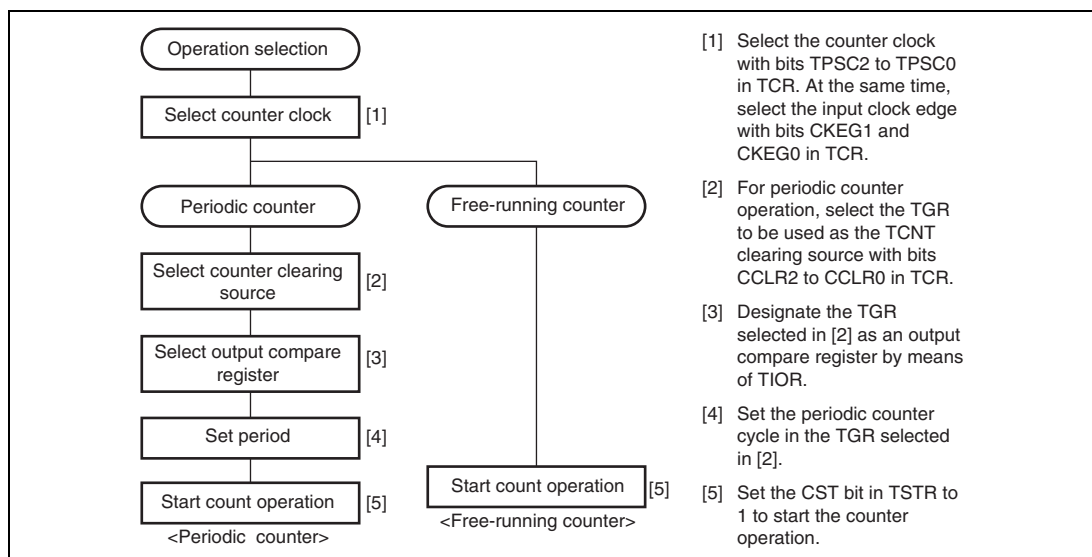

Figure 10.4 Example of Counter Operation Setting Procedure

2. Free-Running Count Operation and Periodic Count Operation:

Immediately after a reset, the MTU2's TCNT counters are all designated as free-running counters. When the relevant bit in TSTR is set to 1 the corresponding TCNT counter starts up-count operation as a free-running counter. When TCNT overflows (from H'FFFF to H'0000), the TCFV bit in TSR is set to 1. If the value of the corresponding TCIEV bit in TIER is 1 at this point, the MTU2 requests an interrupt. After overflow, TCNT starts counting up again from H'0000.

Figure 10.5 illustrates free-running counter operation.

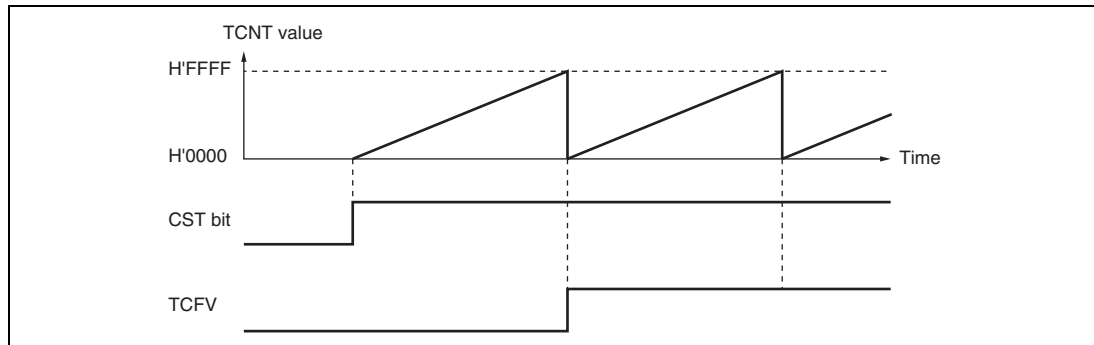

Figure 10.5 Free-Running Counter Operation

When compare match is selected as the TCNT clearing source, the TCNT counter for the relevant channel performs periodic count operation. The TGR register for setting the period is designated as an output compare register, and counter clearing by compare match is selected by means of bits CCLR0 to CCLR2 in TCR. After the settings have been made, TCNT starts up-count operation as a periodic counter when the corresponding bit in TSTR is set to 1. When the count value matches the value in TGR, the TGF bit in TSR is set to 1 and TCNT is cleared to H'0000.

If the value of the corresponding TGIE bit in TIER is 1 at this point, the MTU2 requests an interrupt. After a compare match, TCNT starts counting up again from H'0000.

Figure 10.6 illustrates periodic counter operation.

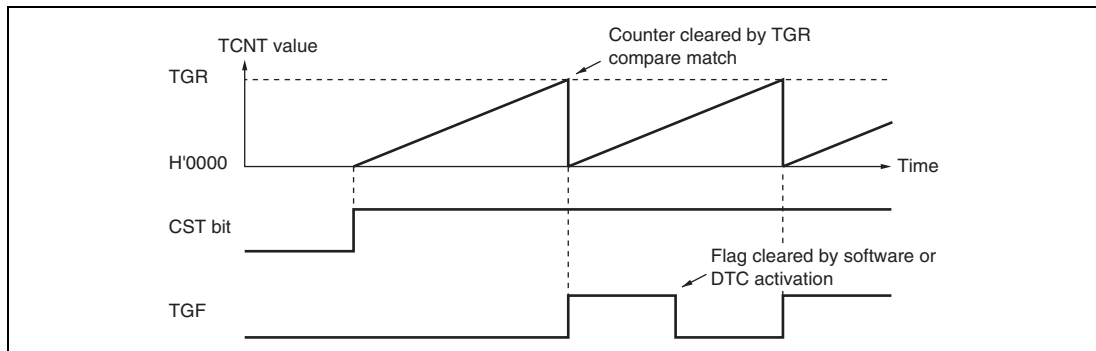

Figure 10.6 Periodic Counter Operation

Waveform Output by Compare Match:

The MTU2 can perform 0, 1, or toggle output from the corresponding output pin using compare match.

1. Example of Setting Procedure for Waveform Output by Compare Match

Figure 10.7 shows an example of the setting procedure for waveform output by compare match

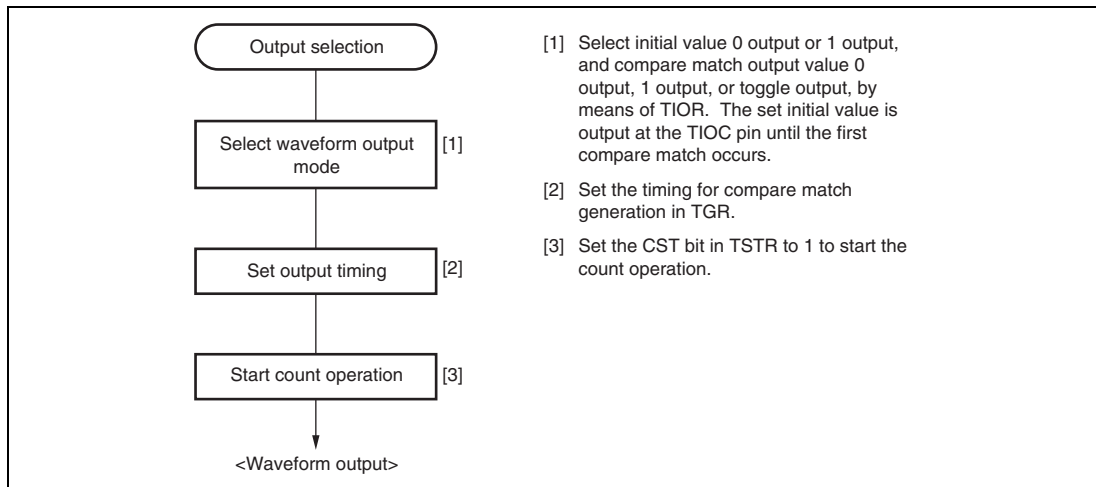

Figure 10.7 Example of Setting Procedure for Waveform Output by Compare Match

2. Examples of Waveform Output Operation:

Figure 10.8 shows an example of 0 output/1 output.

In this example TCNT has been designated as a free-running counter, and settings have been made such that 1 is output by compare match A, and 0 is output by compare match B. When the set level and the pin level coincide, the pin level does not change.

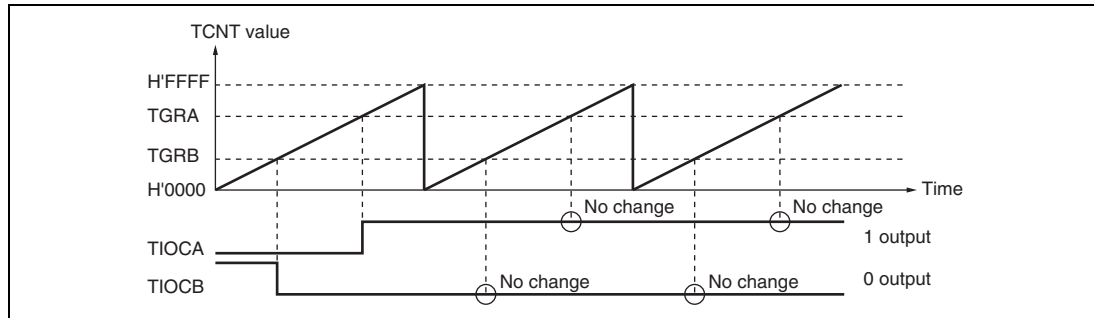

Figure 10.8 Example of 0 Output/1 Output Operation

Figure 10.9 shows an example of toggle output.

In this example, TCNT has been designated as a periodic counter (with counter clearing on compare match B), and settings have been made such that the output is toggled by both compare match A and compare match B.

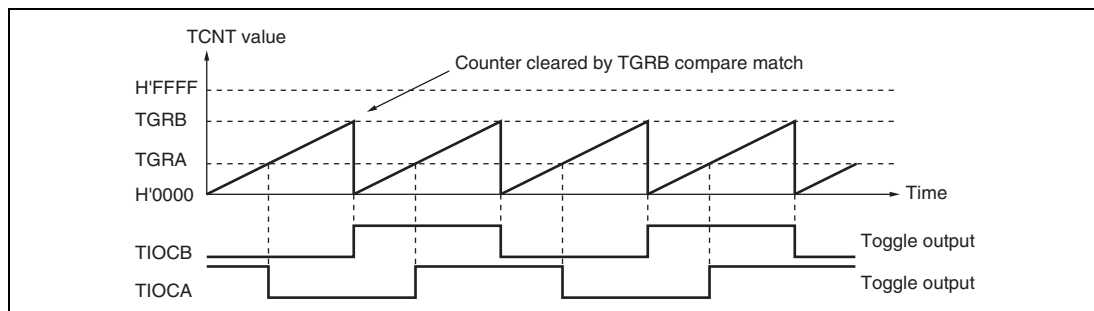

Figure 10.9 Example of Toggle Output Operation

Input Capture Function:

The TCNT value can be transferred to TGR on detection of the TIOC pin input edge.

Rising edge, falling edge, or both edges can be selected as the detected edge. For channels 0 and 1, it is also possible to specify another channel's counter input clock or compare match signal as the input capture source.

Note: When another channel's counter input clock is used as the input capture input for channels 0 and 1, MP ϕ /1 should not be selected as the counter input clock used for input capture input. Input capture will not be generated if MP ϕ /1 is selected.

1. Example of Input Capture Operation Setting Procedure

Figure 10.10 shows an example of the input capture operation setting procedure.

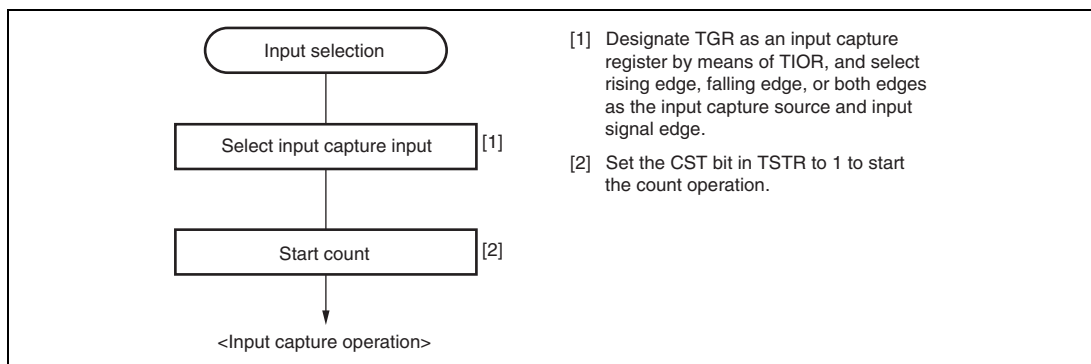

Figure 10.10 Example of Input Capture Operation Setting Procedure

2. Example of Input Capture Operation:

Figure 10.11 shows an example of input capture operation.

In this example both rising and falling edges have been selected as the TIOCA pin input capture input edge, the falling edge has been selected as the TIOCB pin input capture input edge, and counter clearing by TGRB input capture has been designated for TCNT.

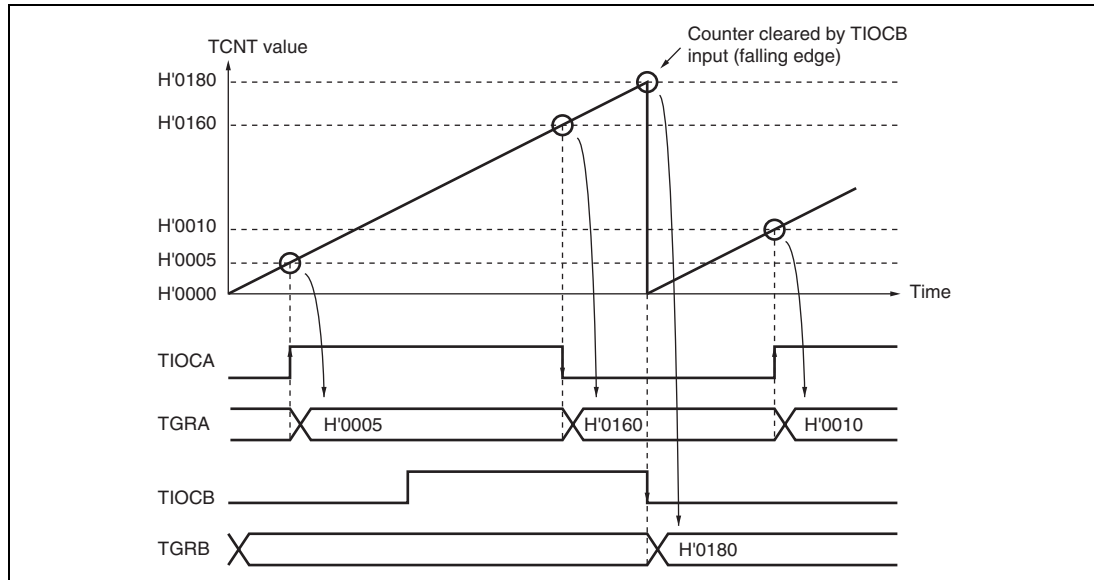

Figure 10.11 Example of Input Capture Operation

10.4.2 Synchronous Operation

In synchronous operation, the values in a number of TCNT counters can be rewritten simultaneously (synchronous presetting). Also, a number of TCNT counters can be cleared simultaneously by making the appropriate setting in TCR (synchronous clearing).

Synchronous operation enables TGR to be incremented with respect to a single time base.

Channels 0 to 4 can all be designated for synchronous operation. Channel 5 cannot be used for synchronous operation.

Example of Synchronous Operation Setting Procedure:

Figure 10.12 shows an example of the synchronous operation setting procedure.

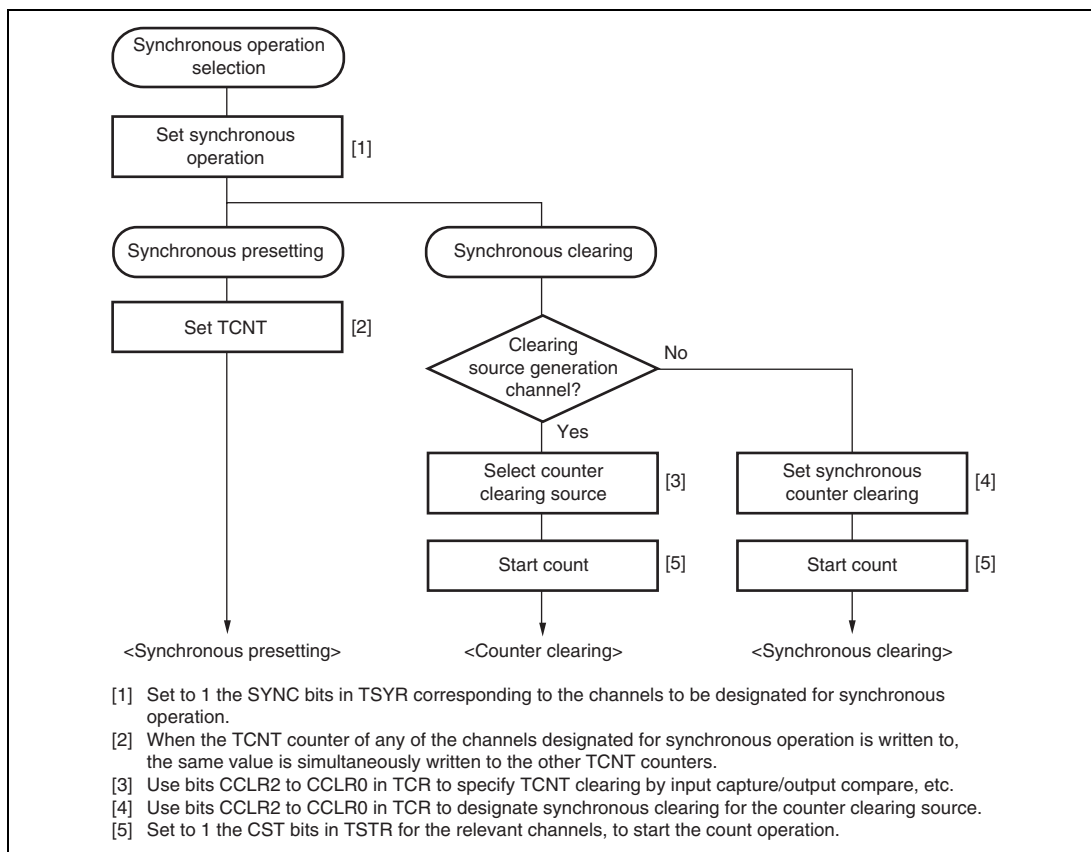

Figure 10.12 Example of Synchronous Operation Setting Procedure

Example of Synchronous Operation: Figure 10.13 shows an example of synchronous operation.

In this example, synchronous operation and PWM mode 1 have been designated for channels 0 to 2, TGRB_0 compare match has been set as the channel 0 counter clearing source, and synchronous clearing has been set for the channel 1 and 2 counter clearing source.

Three-phase PWM waveforms are output from pins TIOC0A, TIOC1A, and TIOC2A. At this time, synchronous presetting, and synchronous clearing by TGRB_0 compare match, are performed for channel 0 to 2 TCNT counters, and the data set in TGRB_0 is used as the PWM cycle.

For details of PWM modes, see section 10.4.5, PWM Modes.

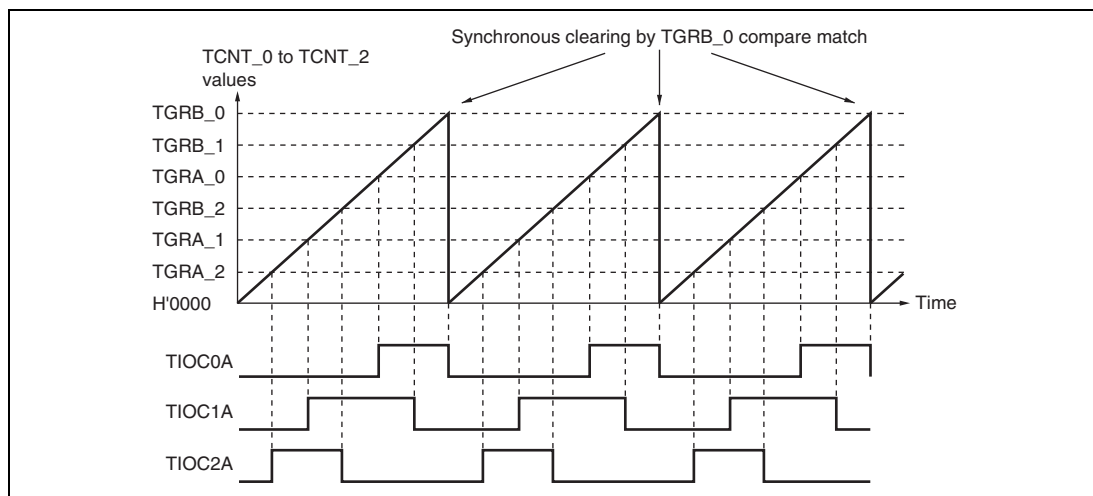

Figure 10.13 Example of Synchronous Operation

10.4.3 Buffer Operation

Buffer operation, provided for channels 0, 3, and 4, enables TGRC and TGRD to be used as buffer registers. In channel 0, TGRF can also be used as a buffer register.

Buffer operation differs depending on whether TGR has been designated as an input capture register or as a compare match register.

Note: TGRE_0 cannot be designated as an input capture register and can only operate as a compare match register.

Table 10.43 shows the register combinations used in buffer operation.

Table 10.43 Register Combinations in Buffer Operation

Channel	Timer General Register	Buffer Register
0	TGRA_0	TGRC_0
	TGRB_0	TGRD_0
	TGRE_0	TGRF_0
3	TGRA_3	TGRC_3
	TGRB_3	TGRD_3
4	TGRA_4	TGRC_4
	TGRB_4	TGRD_4

- When TGR is an output compare register

When a compare match occurs, the value in the buffer register for the corresponding channel is transferred to the timer general register.

This operation is illustrated in figure 10.14.

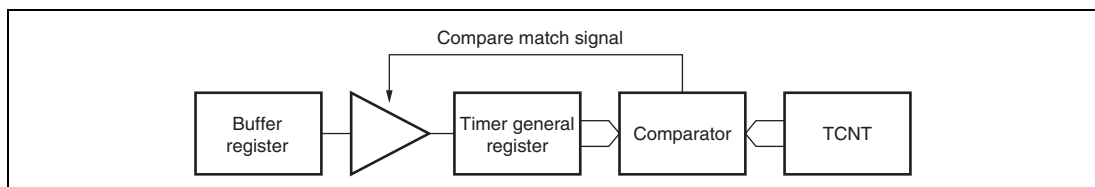

Figure 10.14 Compare Match Buffer Operation

- When TGR is an input capture register

When input capture occurs, the value in TCNT is transferred to TGR and the value previously held in the timer general register is transferred to the buffer register.

This operation is illustrated in figure 10.15.

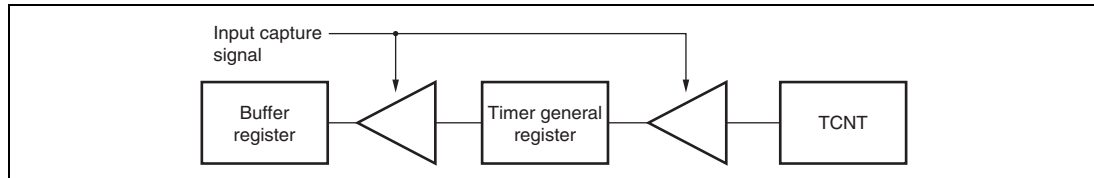

Figure 10.15 Input Capture Buffer Operation

Example of Buffer Operation Setting Procedure: Figure 10.16 shows an example of the buffer operation setting procedure.

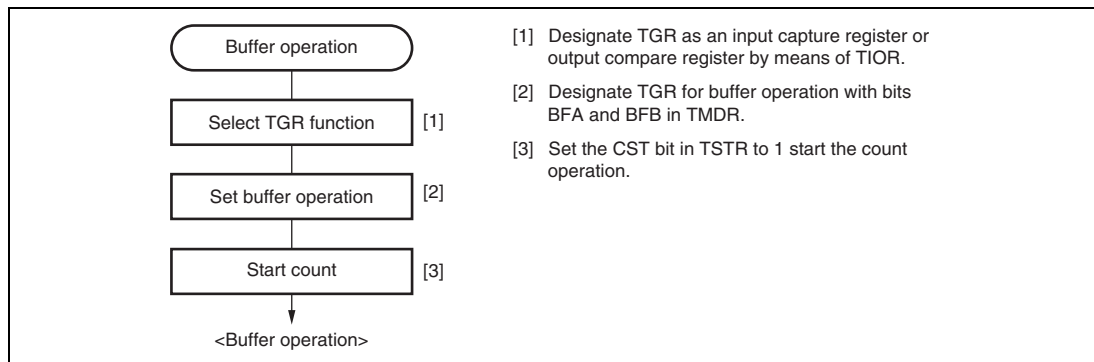

Figure 10.16 Example of Buffer Operation Setting Procedure

Examples of Buffer Operation:

1. When TGR is an output compare register

Figure 10.17 shows an operation example in which PWM mode 1 has been designated for channel 0, and buffer operation has been designated for TGRA and TGRC. The settings used in this example are TCNT clearing by compare match B, 1 output at compare match A, and 0 output at compare match B. In this example, the TTSA bit in TBTM is cleared to 0.

As buffer operation has been set, when compare match A occurs the output changes and the value in buffer register TGRC is simultaneously transferred to timer general register TGRA.

For details of PWM modes, see section 10.4.5, PWM Modes.

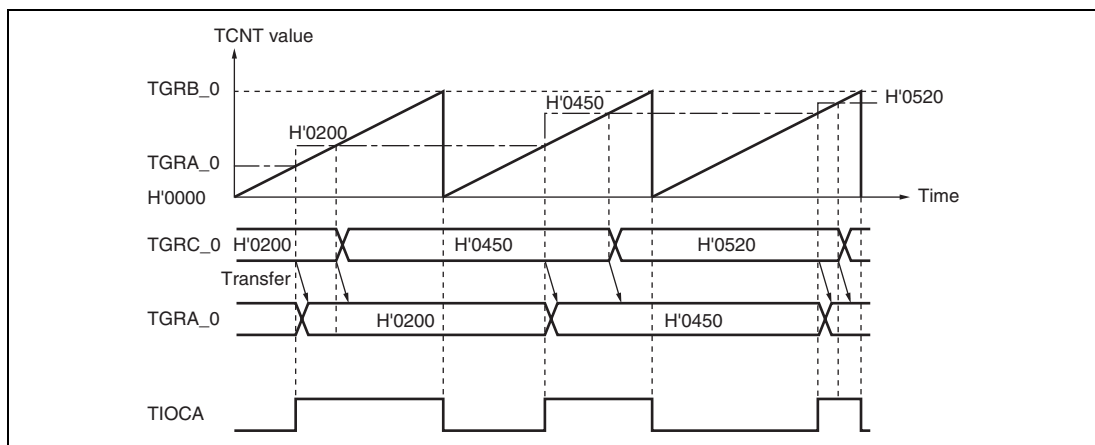

Figure 10.17 Example of Buffer Operation (1)

2. When TGR is an input capture register

Figure 10.18 shows an operation example in which TGRA has been designated as an input capture register, and buffer operation has been designated for TGRA and TGRC.

Counter clearing by TGRA input capture has been set for TCNT, and both rising and falling edges have been selected as the TIOCA pin input capture input edge.

As buffer operation has been set, when the TCNT value is stored in TGRA upon the occurrence of input capture A, the value previously stored in TGRA is simultaneously transferred to TGRC.

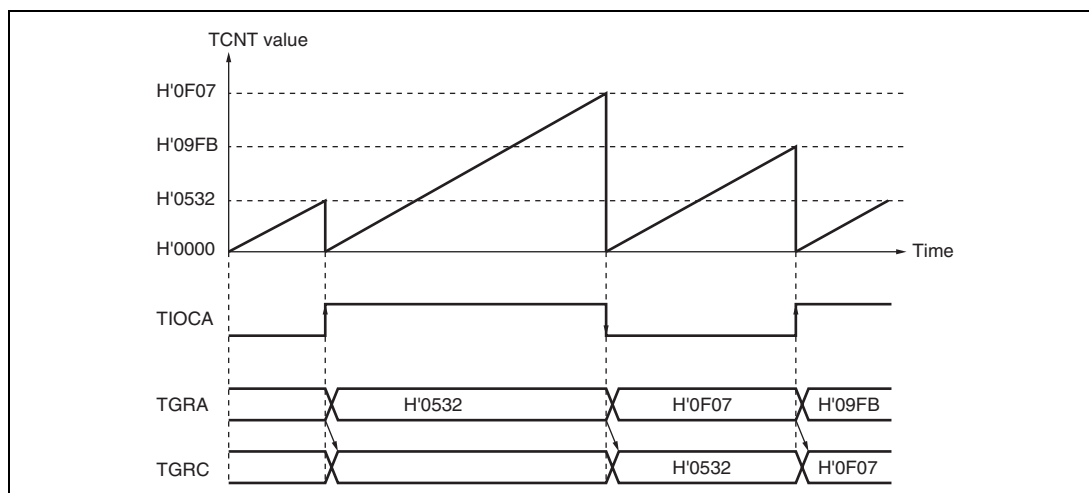

Figure 10.18 Example of Buffer Operation (2)

Selecting Timing for Transfer from Buffer Registers to Timer General Registers in Buffer

Operation: The timing for transfer from buffer registers to timer general registers can be selected in PWM mode 1 or 2 for channel 0 or in PWM mode 1 for channels 3 and 4 by setting the buffer operation transfer mode registers (TBTM_0, TBTM_3, and TBTM_4). Either compare match (initial setting) or TCNT clearing can be selected for the transfer timing. TCNT clearing as transfer timing is one of the following cases.

- When TCNT overflows (H'FFFF to H'0000)
- When H'0000 is written to TCNT during counting
- When TCNT is cleared to H'0000 under the condition specified in the CCLR2 to CCLR0 bits in TCR

Note: TBTM must be modified only while TCNT stops.

Figure 10.19 shows an operation example in which PWM mode 1 is designated for channel 0 and buffer operation is designated for TGRA_0 and TGRC_0. The settings used in this example are TCNT_0 clearing by compare match B, 1 output at compare match A, and 0 output at compare match B. The TTSA bit in TBTM_0 is set to 1.

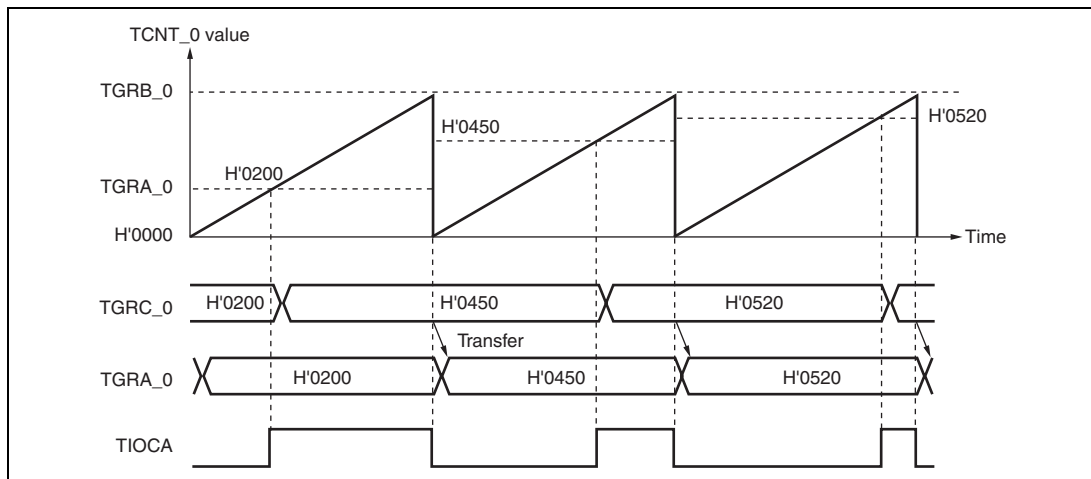

Figure 10.19 Example of Buffer Operation When TCNT_0 Clearing Is Selected for TGRC_0 to TGRA_0 Transfer Timing

10.4.4 Cascaded Operation

In cascaded operation, two 16-bit counters for different channels are used together as a 32-bit counter.

This function works by counting the channel 1 counter clock upon overflow/underflow of TCNT_2 as set in bits TPSC0 to TPSC2 in TCR.

Underflow occurs only when the lower 16-bit TCNT is in phase-counting mode.

Table 10.44 shows the register combinations used in cascaded operation.

Note: When phase counting mode is set for channel 1, the counter clock setting is invalid and the counters operates independently in phase counting mode.

Table 10.44 Cascaded Combinations

Combination	Upper 16 Bits	Lower 16 Bits
Channels 1 and 2	TCNT_1	TCNT_2

For simultaneous input capture of TCNT_1 and TCNT_2 during cascaded operation, additional input capture input pins can be specified by the input capture control register (TICCR). For input capture in cascade connection, refer to section 10.7.22, Simultaneous Capture of TCNT_1 and TCNT_2 in Cascade Connection.

Table 10.45 shows the TICCR setting and input capture input pins.

Table 10.45 TICCR Setting and Input Capture Input Pins

Target Input Capture	TICCR Setting	Input Capture Input Pins
Input capture from TCNT_1 to TGRA_1	I2AE bit = 0 (initial value)	TIOC1A
	I2AE bit = 1	TIOC1A, TIOC2A
Input capture from TCNT_1 to TGRB_1	I2BE bit = 0 (initial value)	TIOC1B
	I2BE bit = 1	TIOC1B, TIOC2B
Input capture from TCNT_2 to TGRA_2	I1AE bit = 0 (initial value)	TIOC2A
	I1AE bit = 1	TIOC2A, TIOC1A
Input capture from TCNT_2 to TGRB_2	I1BE bit = 0 (initial value)	TIOC2B
	I1BE bit = 1	TIOC2B, TIOC1B

Example of Cascaded Operation Setting Procedure: Figure 10.20 shows an example of the setting procedure for cascaded operation.

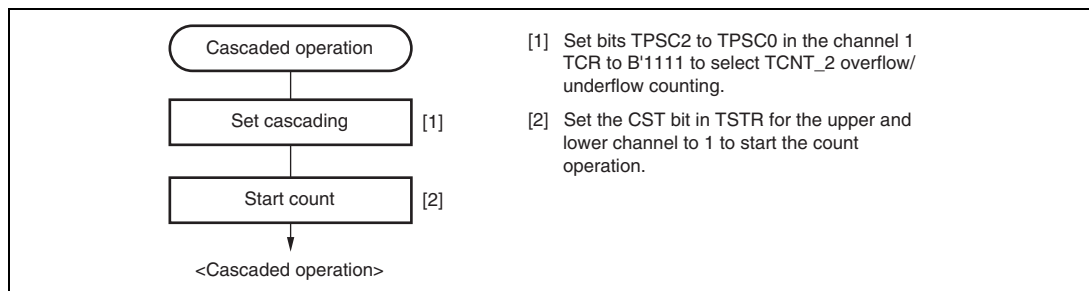

Figure 10.20 Cascaded Operation Setting Procedure

Cascaded Operation Example (a): Figure 10.21 illustrates the operation when TCNT_2 overflow/underflow counting has been set for TCNT_1 and phase counting mode has been designated for channel 2.

TCNT_1 is incremented by TCNT_2 overflow and decremented by TCNT_2 underflow.

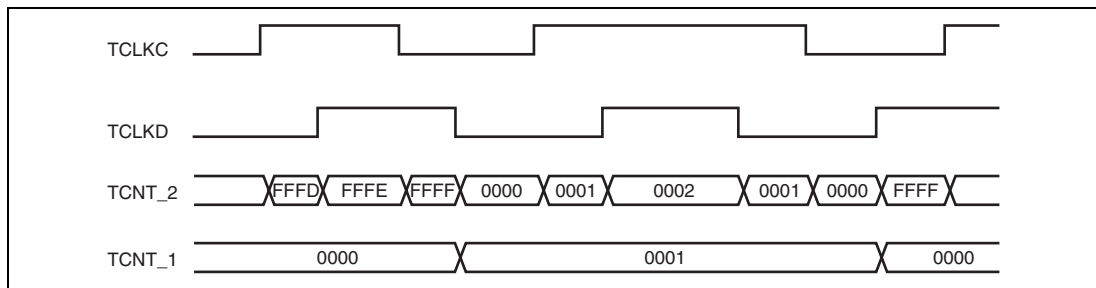

Figure 10.21 Cascaded Operation Example (a)

Cascaded Operation Example (b): Figure 10.22 illustrates the operation when TCNT_1 and TCNT_2 have been cascaded and the I2AE bit in TICCR has been set to 1 to include the TIOC2A pin in the TGRA_1 input capture conditions. In this example, the IOA0 to IOA3 bits in TIOR_1 have selected the TIOC1A rising edge for the input capture timing while the IOA0 to IOA3 bits in TIOR_2 have selected the TIOC2A rising edge for the input capture timing.

Under these conditions, the rising edge of both TIOC1A and TIOC2A is used for the TGRA_1 input capture condition. For the TGRA_2 input capture condition, the TIOC2A rising edge is used.

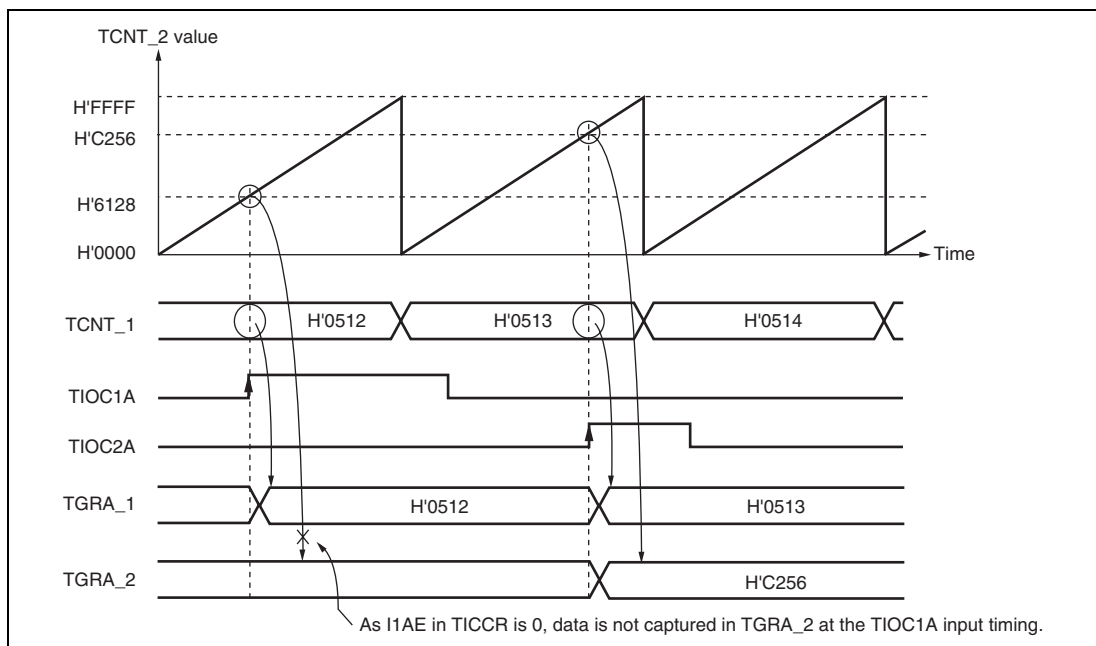

Figure 10.22 Cascaded Operation Example (b)

Cascaded Operation Example (c): Figure 10.23 illustrates the operation when TCNT_1 and TCNT_2 have been cascaded and the I2AE and I1AE bits in TICCR have been set to 1 to include the TIOC2A and TIOC1A pins in the TGRA_1 and TGRA_2 input capture conditions, respectively. In this example, the IOA0 to IOA3 bits in both TIOR_1 and TIOR_2 have selected both the rising and falling edges for the input capture timing. Under these conditions, the ORed result of TIOC1A and TIOC2A input is used for the TGRA_1 and TGRA_2 input capture conditions.

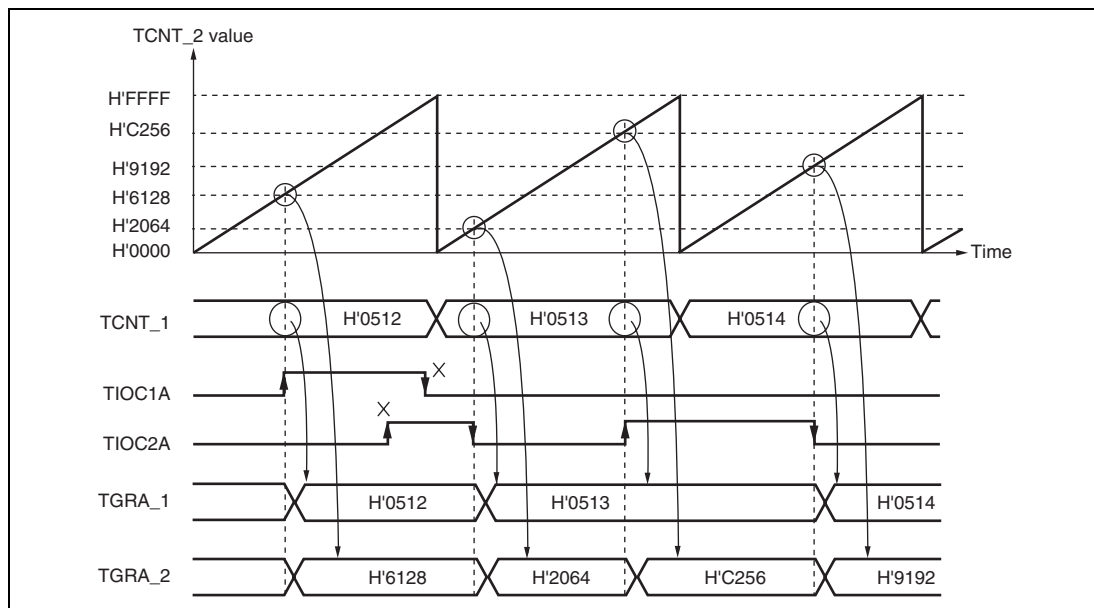

Figure 10.23 Cascaded Operation Example (c)

Cascaded Operation Example (d): Figure 10.24 illustrates the operation when TCNT_1 and TCNT_2 have been cascaded and the I2AE bit in TICCR has been set to 1 to include the TIOC2A pin in the TGRA_1 input capture conditions. In this example, the IOA0 to IOA3 bits in TIOR_1 have selected TGRA_0 compare match or input capture occurrence for the input capture timing while the IOA0 to IOA3 bits in TIOR_2 have selected the TIOC2A rising edge for the input capture timing.

Under these conditions, as TIOR_1 has selected TGRA_0 compare match or input capture occurrence for the input capture timing, the TIOC2A edge is not used for TGRA_1 input capture condition although the I2AE bit in TICCR has been set to 1.

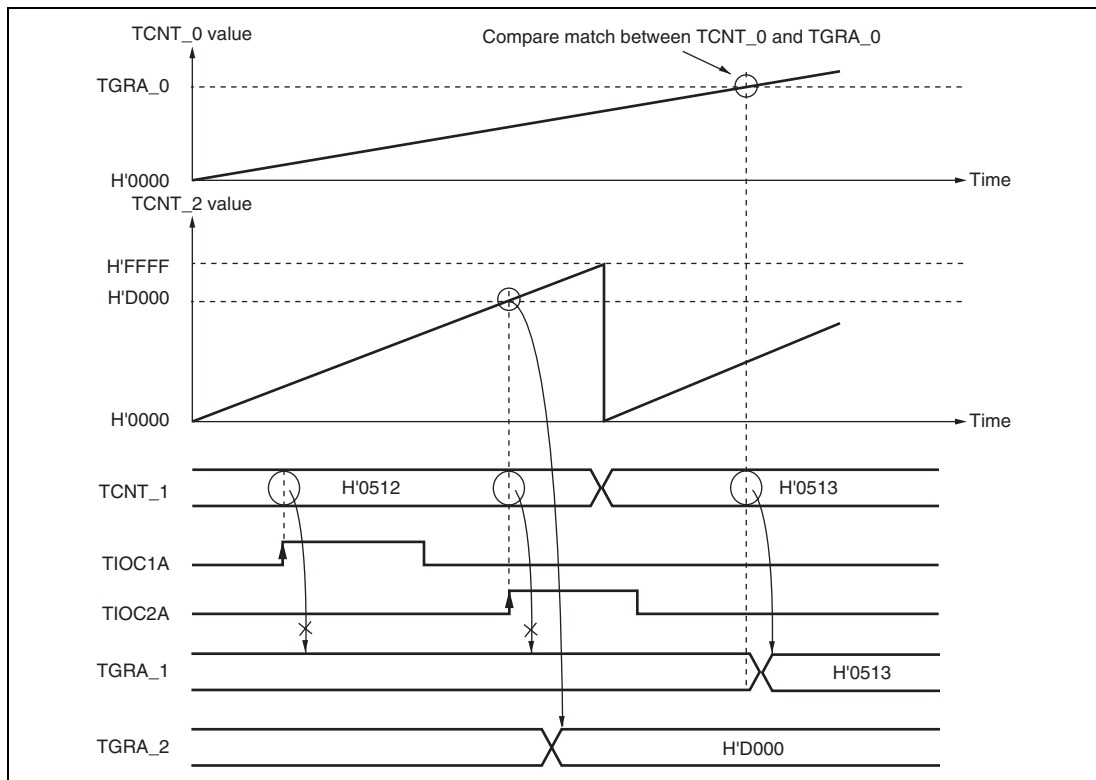

Figure 10.24 Cascaded Operation Example (d)

10.4.5 PWM Modes

In PWM mode, PWM waveforms are output from the output pins. The output level can be selected as 0, 1, or toggle output in response to a compare match of each TGR.

TGR registers settings can be used to output a PWM waveform in the range of 0% to 100% duty.

Designating TGR compare match as the counter clearing source enables the period to be set in that register. All channels can be designated for PWM mode independently. Synchronous operation is also possible.

There are two PWM modes, as described below.

1. PWM mode 1

PWM output is generated from the TIOCA and TIOCC pins by pairing TGRA with TGRB and TGRC with TGRD. The output specified by bits IOA0 to IOA3 and IOC0 to IOC3 in TIOR is output from the TIOCA and TIOCC pins at compare matches A and C, and the output specified by bits IOB0 to IOB3 and IOD0 to IOD3 in TIOR is output at compare matches B and D. The initial output value is the value set in TGRA or TGRC. If the set values of paired TGRs are identical, the output value does not change when a compare match occurs.

In PWM mode 1, a maximum 8-phase PWM output is possible.

2. PWM mode 2

PWM output is generated using one TGR as the cycle register and the others as duty registers. The output specified in TIOR is performed by means of compare matches. Upon counter clearing by a synchronization register compare match, the output value of each pin is the initial value set in TIOR. If the set values of the cycle and duty registers are identical, the output value does not change when a compare match occurs.

In PWM mode 2, a maximum 8-phase PWM output is possible in combination use with synchronous operation.

The correspondence between PWM output pins and registers is shown in table 10.46.

Table 10.46 PWM Output Registers and Output Pins

Channel	Registers	Output Pins	
		PWM Mode 1	PWM Mode 2
0	TGRA_0	TIOC0A	TIOC0A
	TGRB_0		TIOC0B
	TGRC_0	TIOC0C	TIOC0C
	TGRD_0		TIOC0D
1	TGRA_1	TIOC1A	TIOC1A
	TGRB_1		TIOC1B
2	TGRA_2	TIOC2A	TIOC2A
	TGRB_2		TIOC2B
3	TGRA_3	TIOC3A	Cannot be set
	TGRB_3		Cannot be set
	TGRC_3	TIOC3C	Cannot be set
	TGRD_3		Cannot be set
4	TGRA_4	TIOC4A	Cannot be set
	TGRB_4		Cannot be set
	TGRC_4	TIOC4C	Cannot be set
	TGRD_4		Cannot be set

Note: In PWM mode 2, PWM output is not possible for the TGR register in which the period is set.

Example of PWM Mode Setting Procedure: Figure 10.25 shows an example of the PWM mode setting procedure.

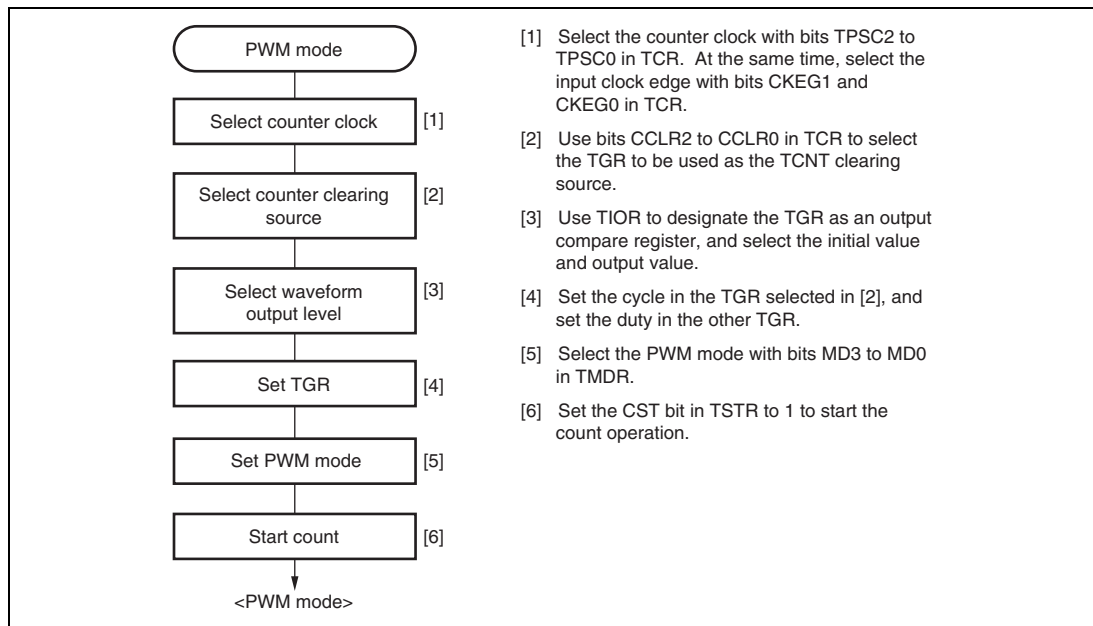

Figure 10.25 Example of PWM Mode Setting Procedure

Examples of PWM Mode Operation: Figure 10.26 shows an example of PWM mode 1 operation.

In this example, TGRA compare match is set as the TCNT clearing source, 0 is set for the TGRA initial output value and output value, and 1 is set as the TGRB output value.

In this case, the value set in TGRA is used as the period, and the values set in the TGRB registers are used as the duty levels.

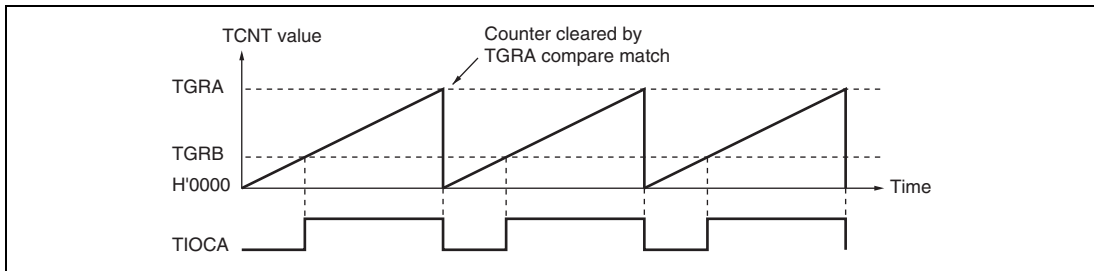

Figure 10.26 Example of PWM Mode Operation (1)

Figure 10.27 shows an example of PWM mode 2 operation.

In this example, synchronous operation is designated for channels 0 and 1, TGRB_1 compare match is set as the TCNT clearing source, and 0 is set for the initial output value and 1 for the output value of the other TGR registers (TGRA_0 to TGRD_0, TGRA_1), outputting a 5-phase PWM waveform.

In this case, the value set in TGRB_1 is used as the cycle, and the values set in the other TGRs are used as the duty levels.

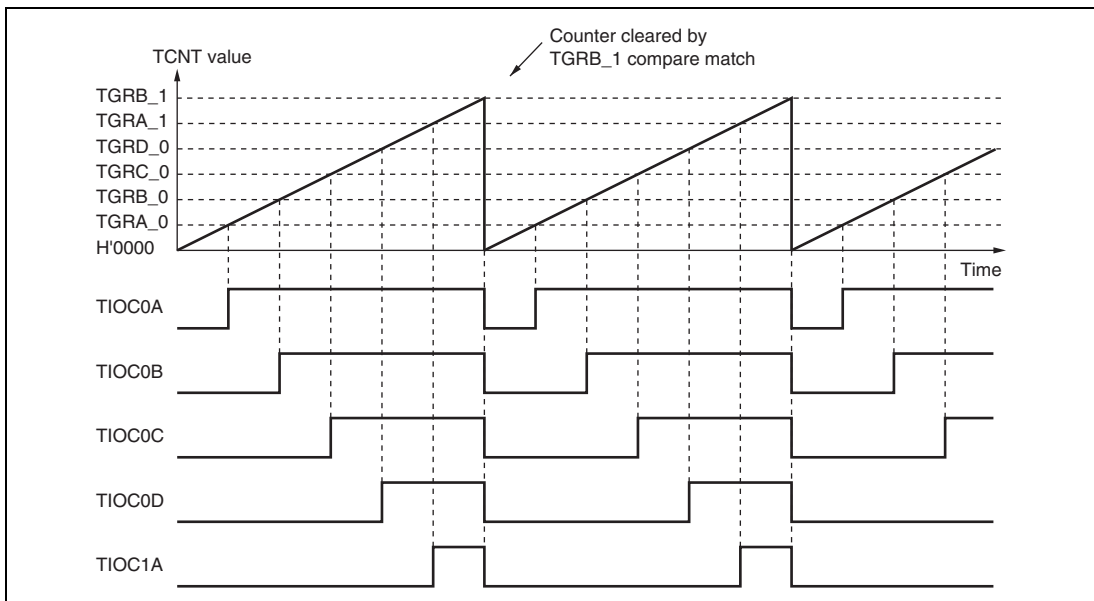

Figure 10.27 Example of PWM Mode Operation (2)

Figure 10.28 shows examples of PWM waveform output with 0% duty and 100% duty in PWM mode.

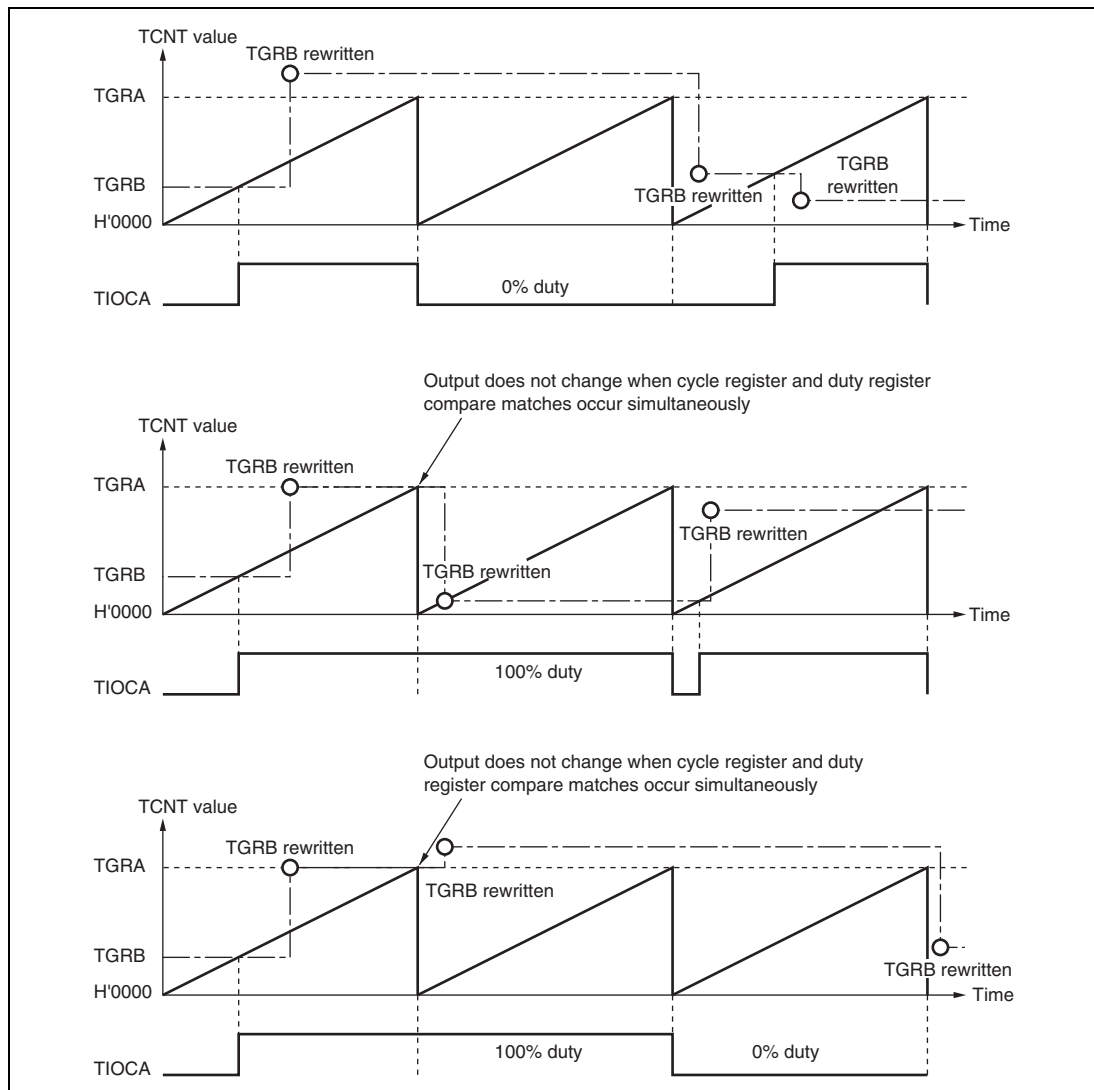

Figure 10.28 Example of PWM Mode Operation (3)

10.4.6 Phase Counting Mode

In phase counting mode, the phase difference between two external clock inputs is detected and TCNT is incremented/decremented accordingly. This mode can be set for channels 1 and 2.

When phase counting mode is set, an external clock is selected as the counter input clock and TCNT operates as an up/down-counter regardless of the setting of bits TPSC0 to TPSC2 and bits CKEG0 and CKEG1 in TCR. However, the functions of bits CCLR0 and CCLR1 in TCR, and of TIOR, TIER, and TGR, are valid, and input capture/compare match and interrupt functions can be used.

This can be used for two-phase encoder pulse input.

If overflow occurs when TCNT is counting up, the TCFV flag in TSR is set; if underflow occurs when TCNT is counting down, the TCFU flag is set.

The TCFD bit in TSR is the count direction flag. Reading the TCFD flag reveals whether TCNT is counting up or down.

Table 10.47 shows the correspondence between external clock pins and channels.

Table 10.47 Phase Counting Mode Clock Input Pins

Channels	External Clock Pins	
	A-Phase	B-Phase
When channel 1 is set to phase counting mode	TCLKA	TCLKB
When channel 2 is set to phase counting mode	TCLKC	TCLKD

Example of Phase Counting Mode Setting Procedure: Figure 10.29 shows an example of the phase counting mode setting procedure.

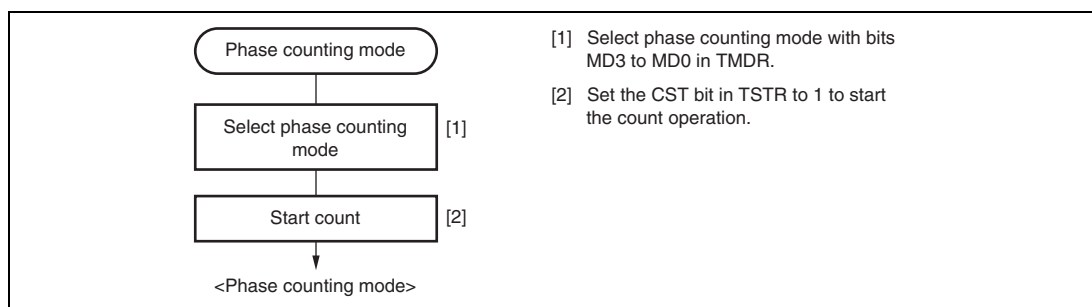

Figure 10.29 Example of Phase Counting Mode Setting Procedure

Examples of Phase Counting Mode Operation: In phase counting mode, TCNT counts up or down according to the phase difference between two external clocks. There are four modes, according to the count conditions.

1. Phase counting mode 1

Figure 10.30 shows an example of phase counting mode 1 operation, and table 10.48 summarizes the TCNT up/down-count conditions.

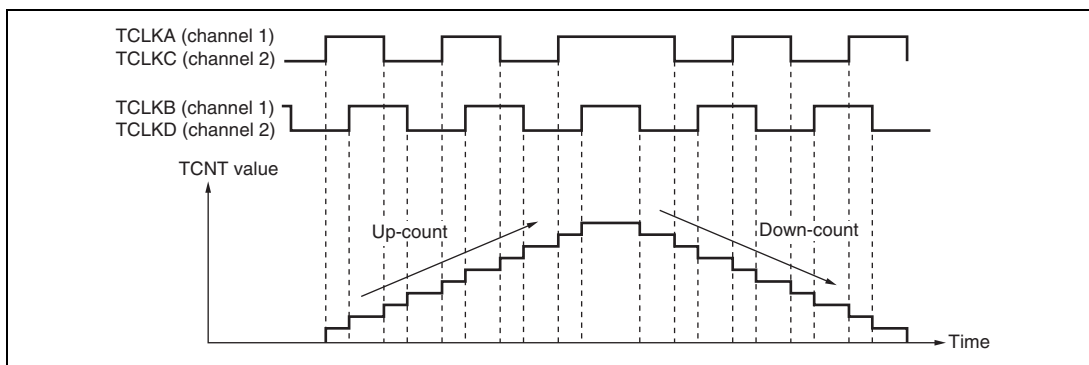

Figure 10.30 Example of Phase Counting Mode 1 Operation

Table 10.48 Up/Down-Count Conditions in Phase Counting Mode 1

TCLKA (Channel 1) TCLKC (Channel 2)	TCLKB (Channel 1) TCLKD (Channel 2)	Operation
High level		Up-count
Low level		
	Low level	
	High level	
High level		Down-count
Low level		
	High level	
	Low level	

[Legend]

- : Rising edge
- : Falling edge

2. Phase counting mode 2

Figure 10.31 shows an example of phase counting mode 2 operation, and table 10.49 summarizes the TCNT up/down-count conditions.

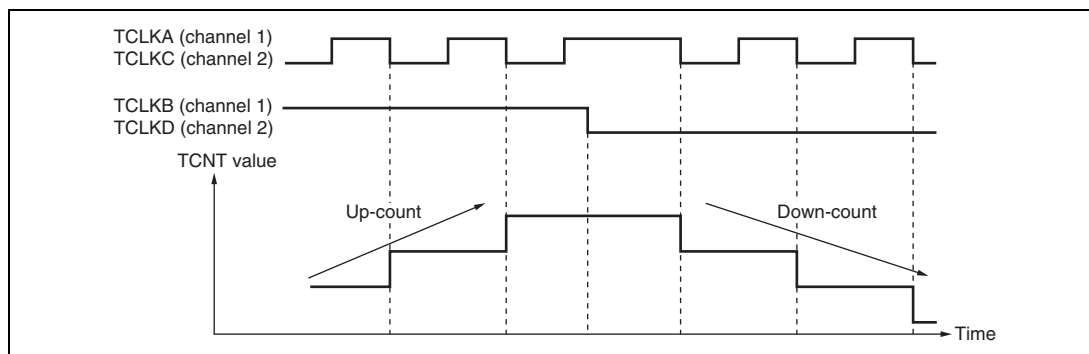

Figure 10.31 Example of Phase Counting Mode 2 Operation

Table 10.49 Up/Down-Count Conditions in Phase Counting Mode 2

TCLKA (Channel 1) TCLKC (Channel 2)	TCLKB (Channel 1) TCLKD (Channel 2)	Operation
High level		Don't care
Low level		Don't care
	Low level	Don't care
	High level	Up-count
High level		Don't care
Low level		Don't care
	High level	Don't care
	Low level	Down-count

[Legend]

: Rising edge
: Falling edge

3. Phase counting mode 3

Figure 10.32 shows an example of phase counting mode 3 operation, and table 10.50 summarizes the TCNT up/down-count conditions.

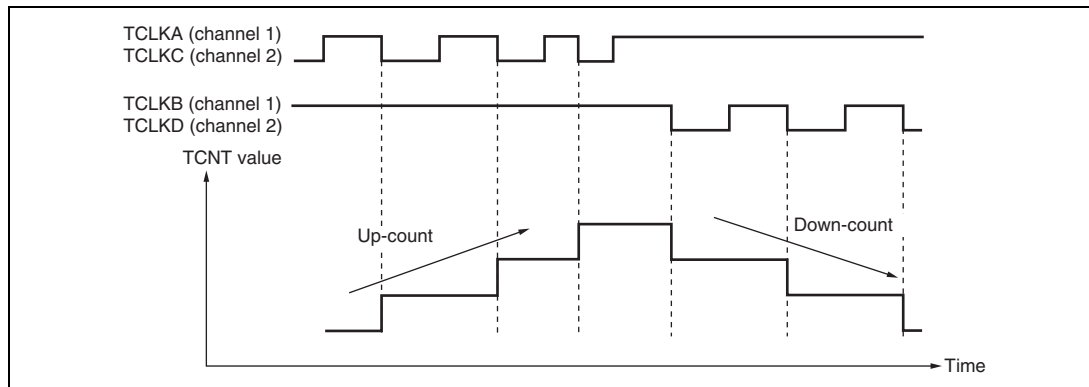

Figure 10.32 Example of Phase Counting Mode 3 Operation

Table 10.50 Up/Down-Count Conditions in Phase Counting Mode 3

TCLKA (Channel 1) TCLKC (Channel 2)	TCLKB (Channel 1) TCLKD (Channel 2)	Operation
High level		Don't care
Low level		Don't care
	Low level	Don't care
	High level	Up-count
High level		Down-count
Low level		Don't care
	High level	Don't care
	Low level	Don't care

[Legend]

: Rising edge
: Falling edge

4. Phase counting mode 4

Figure 10.33 shows an example of phase counting mode 4 operation, and table 10.51 summarizes the TCNT up/down-count conditions.

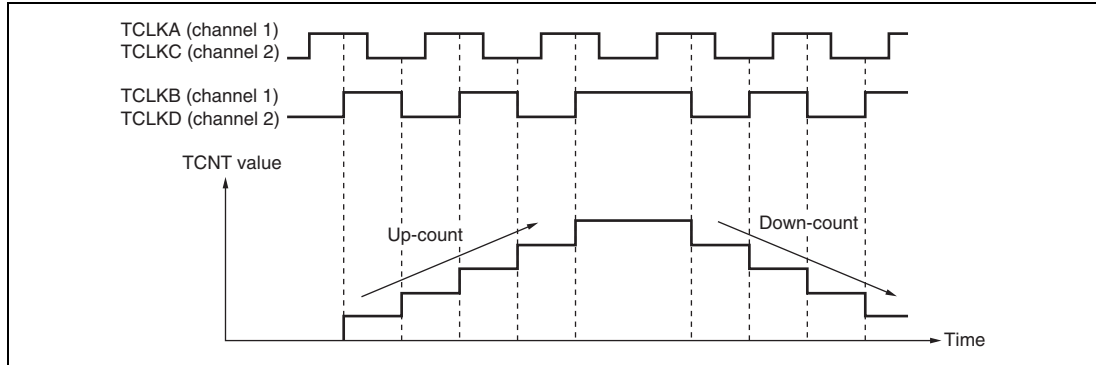

Figure 10.33 Example of Phase Counting Mode 4 Operation

Table 10.51 Up/Down-Count Conditions in Phase Counting Mode 4

TCLKA (Channel 1) TCLKC (Channel 2)	TCLKB (Channel 1) TCLKD (Channel 2)	Operation
High level		Up-count
Low level		Up-count
	Low level	Don't care
	High level	Don't care
High level		Down-count
Low level		Down-count
	High level	Don't care
	Low level	Don't care

[Legend]

: Rising edge
: Falling edge

Phase Counting Mode Application Example: Figure 10.34 shows an example in which channel 1 is in phase counting mode, and channel 1 is coupled with channel 0 to input servo motor 2-phase encoder pulses in order to detect position or speed.

Channel 1 is set to phase counting mode 1, and the encoder pulse A-phase and B-phase are input to TCLKA and TCLKB.

Channel 0 operates with TCNT counter clearing by TGRC_0 compare match; TGRA_0 and TGRC_0 are used for the compare match function and are set with the speed control period and position control period. TGRB_0 is used for input capture, with TGRB_0 and TGRD_0 operating in buffer mode. The channel 1 counter input clock is designated as the TGRB_0 input capture source, and the pulse widths of 2-phase encoder 4-multiplication pulses are detected.

TGRA_1 and TGRB_1 for channel 1 are designated for input capture, and channel 0 TGRA_0 and TGRC_0 compare matches are selected as the input capture source and store the up/down-counter values for the control periods.

This procedure enables the accurate detection of position and speed.

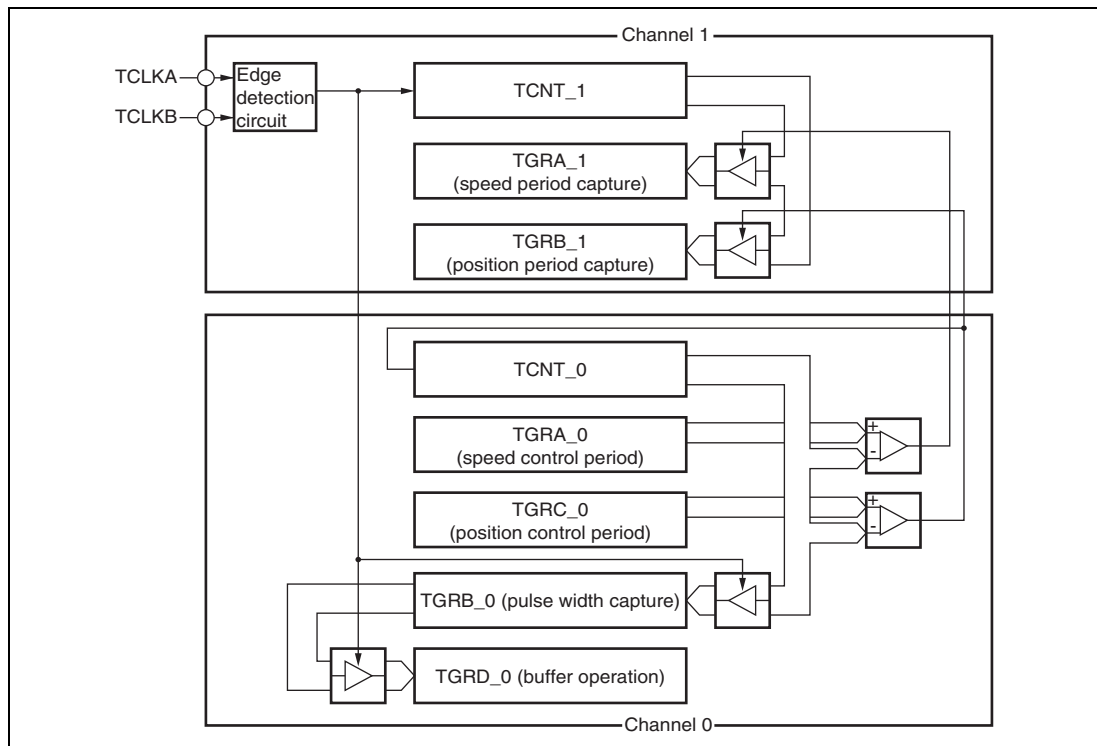

Figure 10.34 Phase Counting Mode Application Example

10.4.7 Reset-Synchronized PWM Mode

In the reset-synchronized PWM mode, three-phase output of positive and negative PWM waveforms that share a common wave transition point can be obtained by combining channels 3 and 4.

When set for reset-synchronized PWM mode, the TIOC3B, TIOC3D, TIOC4A, TIOC4C, TIOC4B, and TIOC4D pins function as PWM output pins and TCNT3 functions as an upcounter.

Table 10.52 shows the PWM output pins used. Table 10.53 shows the settings of the registers.

Table 10.52 Output Pins for Reset-Synchronized PWM Mode

Channel	Output Pin	Description
3	TIOC3B	PWM output pin 1
	TIOC3D	PWM output pin 1' (negative-phase waveform of PWM output 1)
4	TIOC4A	PWM output pin 2
	TIOC4C	PWM output pin 2' (negative-phase waveform of PWM output 2)
	TIOC4B	PWM output pin 3
	TIOC4D	PWM output pin 3' (negative-phase waveform of PWM output 3)

Table 10.53 Register Settings for Reset-Synchronized PWM Mode

Register	Description of Setting
TCNT_3	Initial setting of H'0000
TCNT_4	Initial setting of H'0000
TGRA_3	Set count cycle for TCNT_3
TGRB_3	Sets the turning point for PWM waveform output by the TIOC3B and TIOC3D pins
TGRA_4	Sets the turning point for PWM waveform output by the TIOC4A and TIOC4C pins
TGRB_4	Sets the turning point for PWM waveform output by the TIOC4B and TIOC4D pins

Procedure for Selecting the Reset-Synchronized PWM Mode: Figure 10.35 shows an example of procedure for selecting the reset synchronized PWM mode.

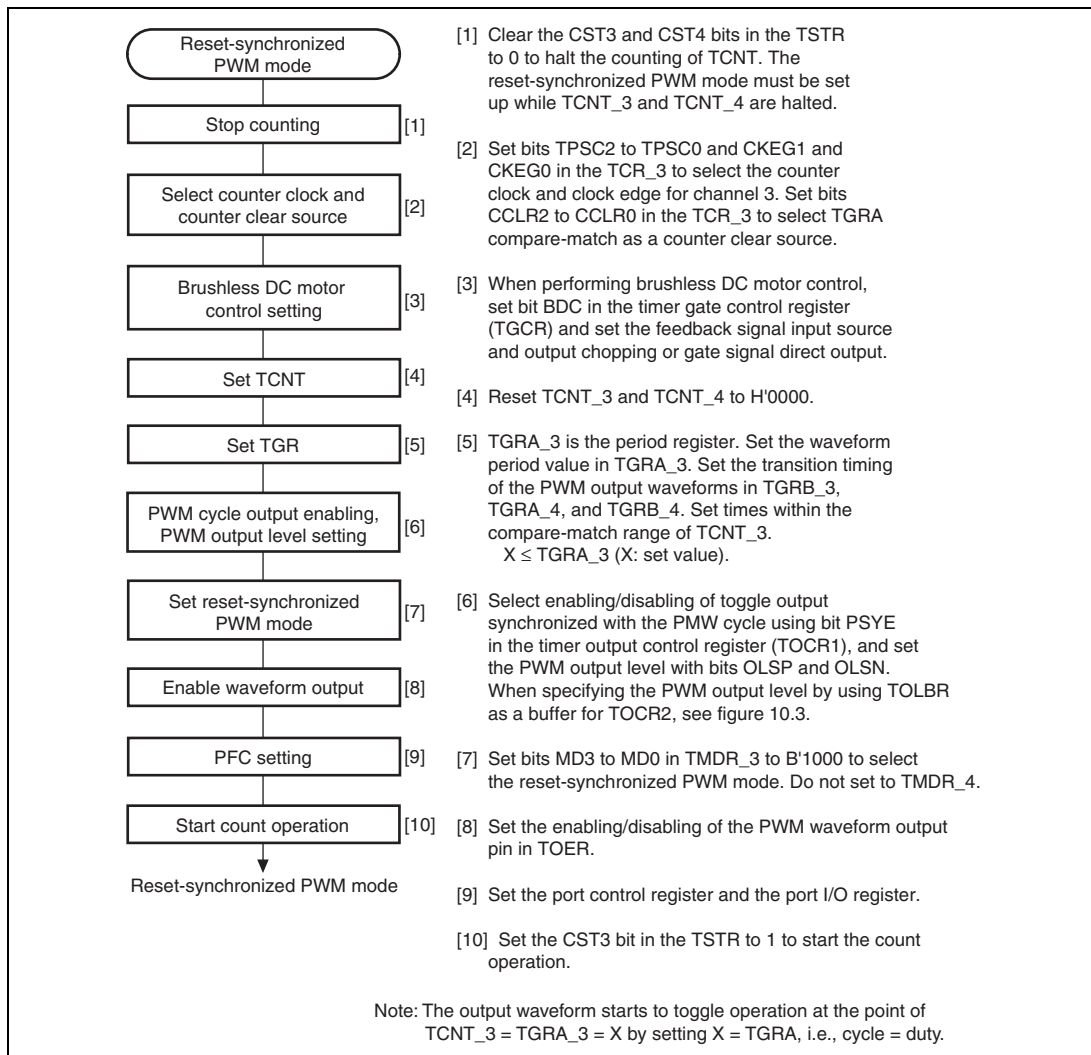
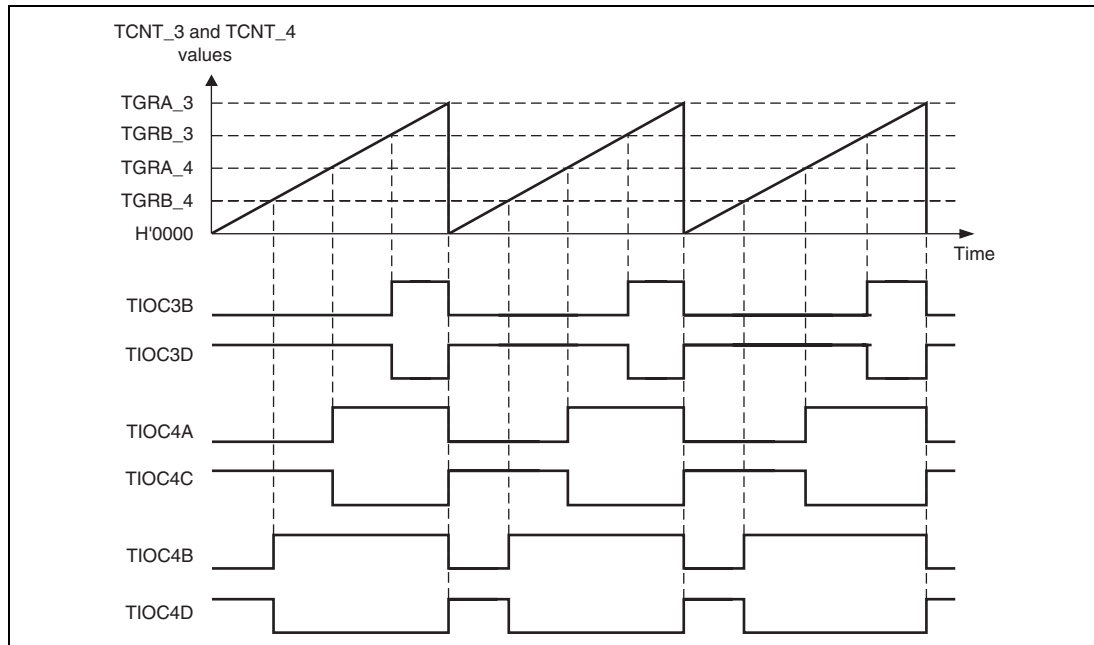

Figure 10.35 Procedure for Selecting Reset-Synchronized PWM Mode

Reset-Synchronized PWM Mode Operation: Figure 10.36 shows an example of operation in the reset-synchronized PWM mode. TCNT_3 and TCNT_4 operate as upcounters. The counter is cleared when a TCNT_3 and TGRA_3 compare-match occurs, and then begins incrementing from H'0000. The PWM output pin output toggles with each occurrence of a TGRB_3, TGRA_4, TGRB_4 compare-match, and upon counter clears.



**Figure 10.36 Reset-Synchronized PWM Mode Operation Example
(When TOCR's OLSN = 1 and OLSP = 1)**

10.4.8 Complementary PWM Mode

In the complementary PWM mode, three-phase output of non-overlapping positive and negative PWM waveforms can be obtained by combining channels 3 and 4. PWM waveforms without non-overlapping interval is also available.

In complementary PWM mode, TIOC3B, TIOC3D, TIOC4A, TIOC4B, TIOC4C, and TIOC4D pins function as PWM output pins, the TIOC3A pin can be set for toggle output synchronized with the PWM period. TCNT_3 and TCNT_4 function as up/down counters.

Table 10.54 shows the PWM output pins used. Table 10.55 shows the settings of the registers used.

A function to directly cut off the PWM output by using an external signal is supported as a port function.

Table 10.54 Output Pins for Complementary PWM Mode

Channel	Output Pin	Description
3	TIOC3A	Toggle output synchronized with PWM period (or I/O port)
	TIOC3B	PWM output pin 1
	TIOC3C	I/O port*
	TIOC3D	PWM output pin 1' (non-overlapping negative-phase waveform of PWM output 1; PWM output without non-overlapping interval is also available)
4	TIOC4A	PWM output pin 2
	TIOC4B	PWM output pin 3
	TIOC4C	PWM output pin 2' (non-overlapping negative-phase waveform of PWM output 2; PWM output without non-overlapping interval is also available)
	TIOC4D	PWM output pin 3' (non-overlapping negative-phase waveform of PWM output 3; PWM output without non-overlapping interval is also available)

Note: * Avoid setting the TIOC3C pin as a timer I/O pin in the complementary PWM mode.

Table 10.55 Register Settings for Complementary PWM Mode

Channel	Counter/Register	Description	Read/Write from CPU
3	TCNT_3	Start of up-count from value set in dead time register	Maskable by TRWER setting*
	TGRA_3	Set TCNT_3 upper limit value (1/2 carrier cycle + dead time)	Maskable by TRWER setting*
	TGRB_3	PWM output 1 compare register	Maskable by TRWER setting*
	TGRC_3	TGRA_3 buffer register	Always readable/writable
	TGRD_3	PWM output 1/TGRB_3 buffer register	Always readable/writable
4	TCNT_4	Up-count start, initialized to H'0000	Maskable by TRWER setting*
	TGRA_4	PWM output 2 compare register	Maskable by TRWER setting*
	TGRB_4	PWM output 3 compare register	Maskable by TRWER setting*
	TGRC_4	PWM output 2/TGRA_4 buffer register	Always readable/writable
	TGRD_4	PWM output 3/TGRB_4 buffer register	Always readable/writable
	Timer dead time data register (TDDR)	Set TCNT_4 and TCNT_3 offset value (dead time value)	Maskable by TRWER setting*
	Timer cycle data register (TCDR)	Set TCNT_4 upper limit value (1/2 carrier cycle)	Maskable by TRWER setting*
	Timer cycle buffer register (TCBR)	TCDR buffer register	Always readable/writable
	Subcounter (TCNTS)	Subcounter for dead time generation	Read-only
	Temporary register 1 (TEMP1)	PWM output 1/TGRB_3 temporary register	Not readable/writable
	Temporary register 2 (TEMP2)	PWM output 2/TGRA_4 temporary register	Not readable/writable
	Temporary register 3 (TEMP3)	PWM output 3/TGRB_4 temporary register	Not readable/writable

Note: * Access can be enabled or disabled according to the setting of bit 0 (RWE) in TRWER (timer read/write enable register).

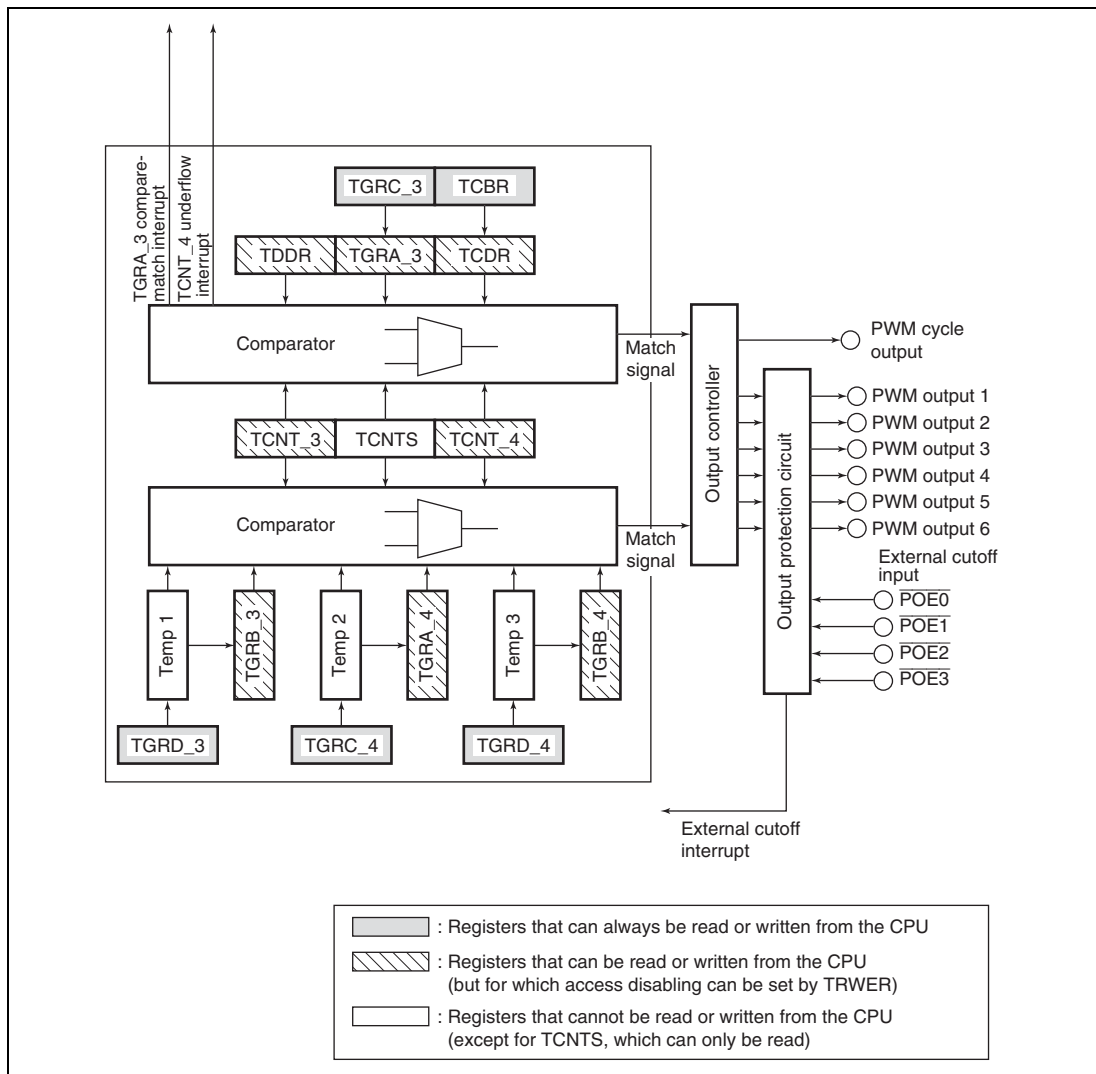

Figure 10.37 Block Diagram of Channels 3 and 4 in Complementary PWM Mode

Example of Complementary PWM Mode Setting Procedure: An example of the complementary PWM mode setting procedure is shown in figure 10.38.

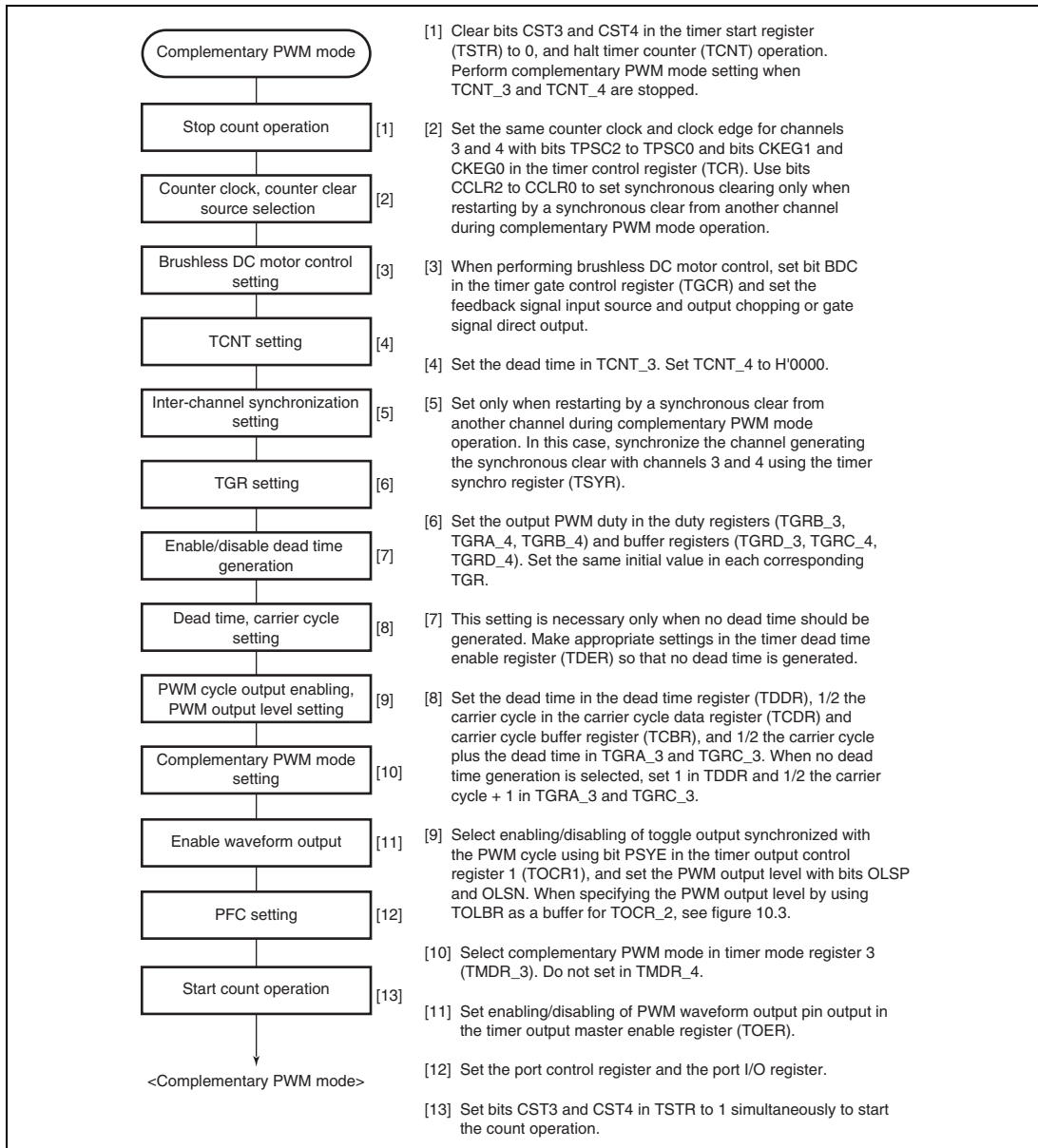

Figure 10.38 Example of Complementary PWM Mode Setting Procedure

Outline of Complementary PWM Mode Operation:

In complementary PWM mode, 6-phase PWM output is possible. Figure 10.39 illustrates counter operation in complementary PWM mode, and figure 10.40 shows an example of complementary PWM mode operation.

1. Counter Operation

In complementary PWM mode, three counters—TCNT_3, TCNT_4, and TCNTS—perform up/down-count operations.

TCNT_3 is automatically initialized to the value set in TDDR when complementary PWM mode is selected and the CST bit in TSTR is 0.

When the CST bit is set to 1, TCNT_3 counts up to the value set in TGRA_3, then switches to down-counting when it matches TGRA_3. When the TCNT3 value matches TDDR, the counter switches to up-counting, and the operation is repeated in this way.

TCNT_4 is initialized to H'0000.

When the CST bit is set to 1, TCNT4 counts up in synchronization with TCNT_3, and switches to down-counting when it matches TCDR. On reaching H'0000, TCNT4 switches to up-counting, and the operation is repeated in this way.

TCNTS is a read-only counter. It need not be initialized.

When TCNT_3 matches TCDR during TCNT_3 and TCNT_4 up/down-counting, down-counting is started, and when TCNTS matches TCDR, the operation switches to up-counting. When TCNTS matches TGRA_3, it is cleared to H'0000.

When TCNT_4 matches TDDR during TCNT_3 and TCNT_4 down-counting, up-counting is started, and when TCNTS matches TDDR, the operation switches to down-counting. When TCNTS reaches H'0000, it is set with the value in TGRA_3.

TCNTS is compared with the compare register and temporary register in which the PWM duty is set during the count operation only.

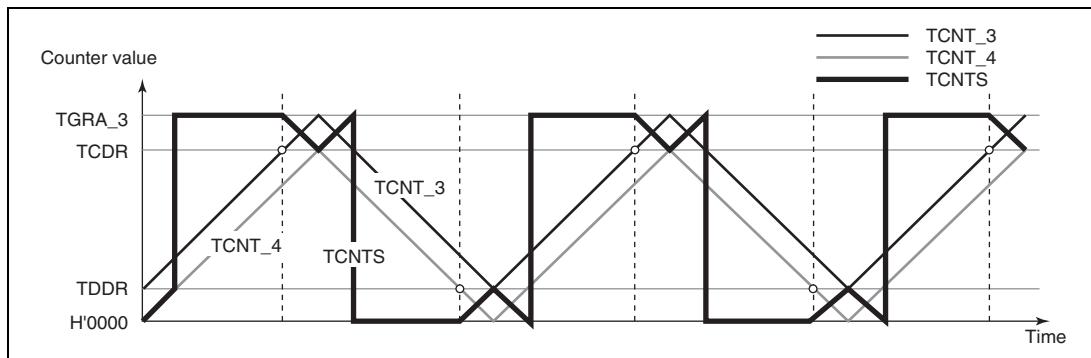

Figure 10.39 Complementary PWM Mode Counter Operation

2. Register Operation

In complementary PWM mode, nine registers are used, comprising compare registers, buffer registers, and temporary registers. Figure 10.40 shows an example of complementary PWM mode operation.

The registers which are constantly compared with the counters to perform PWM output are TGRB_3, TGRA_4, and TGRB_4. When these registers match the counter, the value set in bits OLSN and OLSP in the timer output control register (TOCR) is output.

The buffer registers for these compare registers are TGRD_3, TGRC_4, and TGRD_4.

Between a buffer register and compare register there is a temporary register. The temporary registers cannot be accessed by the CPU.

Data in a compare register is changed by writing the new data to the corresponding buffer register. The buffer registers can be read or written at any time.

The data written to a buffer register is constantly transferred to the temporary register in the Ta interval. Data is not transferred to the temporary register in the Tb interval. Data written to a buffer register in this interval is transferred to the temporary register at the end of the Tb interval.

The value transferred to a temporary register is transferred to the compare register when TCNTS for which the Tb interval ends matches TGRA_3 when counting up, or H'0000 when counting down. The timing for transfer from the temporary register to the compare register can be selected with bits MD3 to MD0 in the timer mode register (TMDR). Figure 10.40 shows an example in which the mode is selected in which the change is made in the trough.

In the Tb interval (Tb1 in figure 10.40) in which data transfer to the temporary register is not performed, the temporary register has the same function as the compare register, and is compared with the counter. In this interval, therefore, there are two compare match registers for one-phase output, with the compare register containing the pre-change data, and the temporary register containing the new data. In this interval, the three counters—TCNT_3, TCNT_4, and TCNTS—and two registers—compare register and temporary register—are compared, and PWM output controlled accordingly.

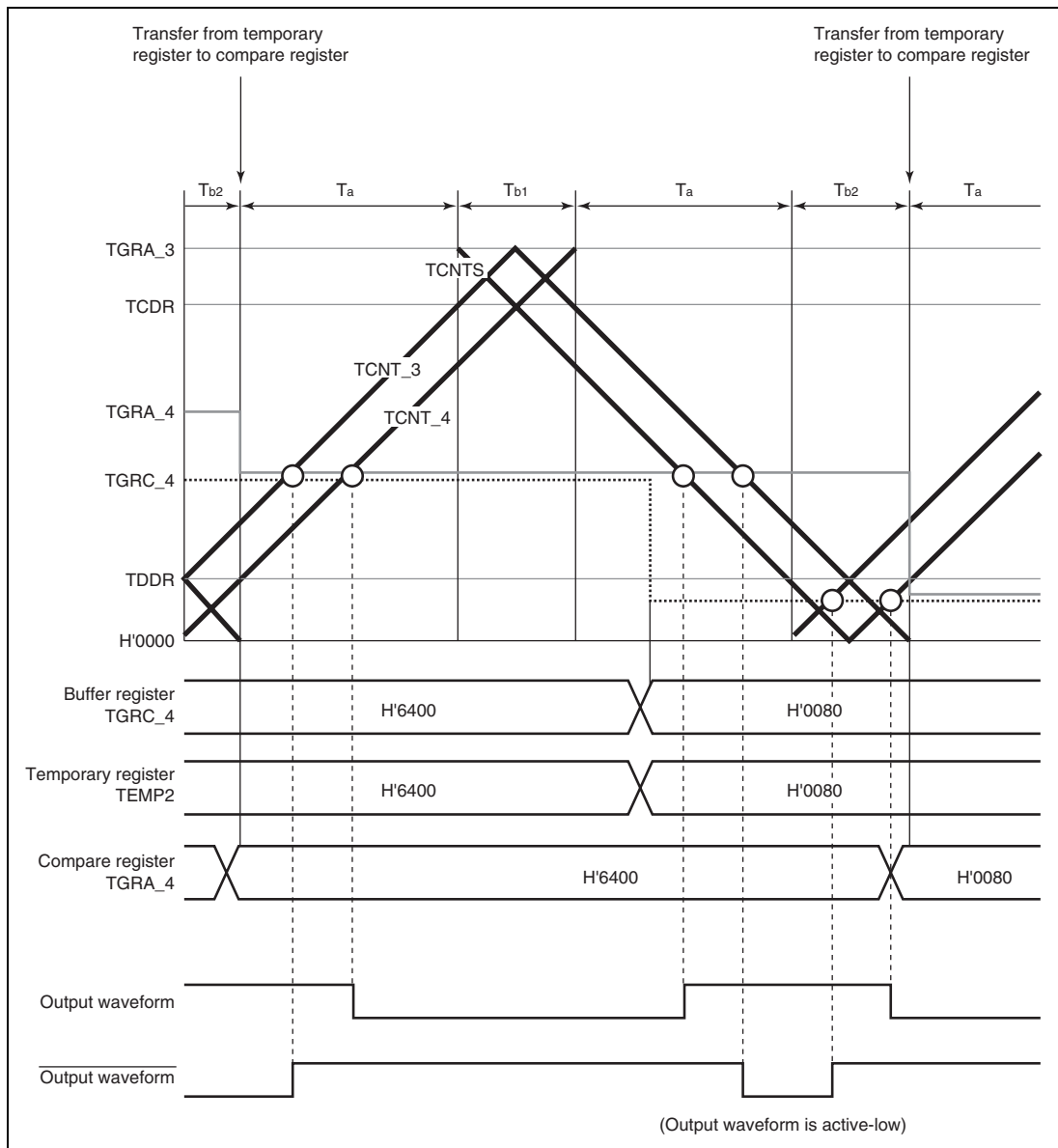

Figure 10.40 Example of Complementary PWM Mode Operation

3. Initialization

In complementary PWM mode, there are six registers that must be initialized. In addition, there is a register that specifies whether to generate dead time (it should be used only when dead time generation should be disabled).

Before setting complementary PWM mode with bits MD3 to MD0 in the timer mode register (TMDR), the following initial register values must be set.

TGRC_3 operates as the buffer register for TGRA_3, and should be set with 1/2 the PWM carrier cycle + dead time Td. The timer cycle buffer register (TCBR) operates as the buffer register for the timer cycle data register (TCDR), and should be set with 1/2 the PWM carrier cycle. Set dead time Td in the timer dead time data register (TDDR).

When dead time is not needed, the TDER bit in the timer dead time enable register (TDER) should be cleared to 0, TGRC_3 and TGRA_3 should be set to 1/2 the PWM carrier cycle + 1, and TDDR should be set to 1.

Set the respective initial PWM duty values in buffer registers TGRD_3, TGRC_4, and TGRD_4.

The values set in the five buffer registers excluding TDDR are transferred simultaneously to the corresponding compare registers when complementary PWM mode is set.

Set TCNT_4 to H'0000 before setting complementary PWM mode.

Table 10.56 Registers and Counters Requiring Initialization

Register/Counter	Set Value
TGRC_3	1/2 PWM carrier cycle + dead time Td (1/2 PWM carrier cycle + 1 when dead time generation is disabled by TDER)
TDDR	Dead time Td (1 when dead time generation is disabled by TDER)
TCBR	1/2 PWM carrier cycle
TGRD_3, TGRC_4, TGRD_4	Initial PWM duty value for each phase
TCNT_4	H'0000

Note: The TGRC_3 set value must be the sum of 1/2 the PWM carrier cycle set in TCBR and dead time Td set in TDDR. When dead time generation is disabled by TDER, TGRC_3 must be set to 1/2 the PWM carrier cycle + 1.

4. PWM Output Level Setting

In complementary PWM mode, the PWM pulse output level is set with bits OLSN and OLSP in timer output control register 1 (TOCR1) or bits OLS1P to OLS3P and OLS1N to OLS3N in timer output control register 2 (TOCR2).

The output level can be set for each of the three positive phases and three negative phases of 6-phase output.

Complementary PWM mode should be cleared before setting or changing output levels.

5. Dead Time Setting

In complementary PWM mode, PWM pulses are output with a non-overlapping relationship between the positive and negative phases. This non-overlap time is called the dead time.

The non-overlap time is set in the timer dead time data register (TDDR). The value set in TDDR is used as the TCNT_3 counter start value, and creates non-overlap between TCNT_3 and TCNT_4. Complementary PWM mode should be cleared before changing the contents of TDDR.

6. Dead Time Suppressing

Dead time generation is suppressed by clearing the TDER bit in the timer dead time enable register (TDER) to 0. TDER can be cleared to 0 only when 0 is written to it after reading TDER = 1.

TGRA_3 and TGRC_3 should be set to 1/2 PWM carrier cycle + 1 and the timer dead time data register (TDDR) should be set to 1.

By the above settings, PWM waveforms without dead time can be obtained. Figure 10.41 shows an example of operation without dead time.

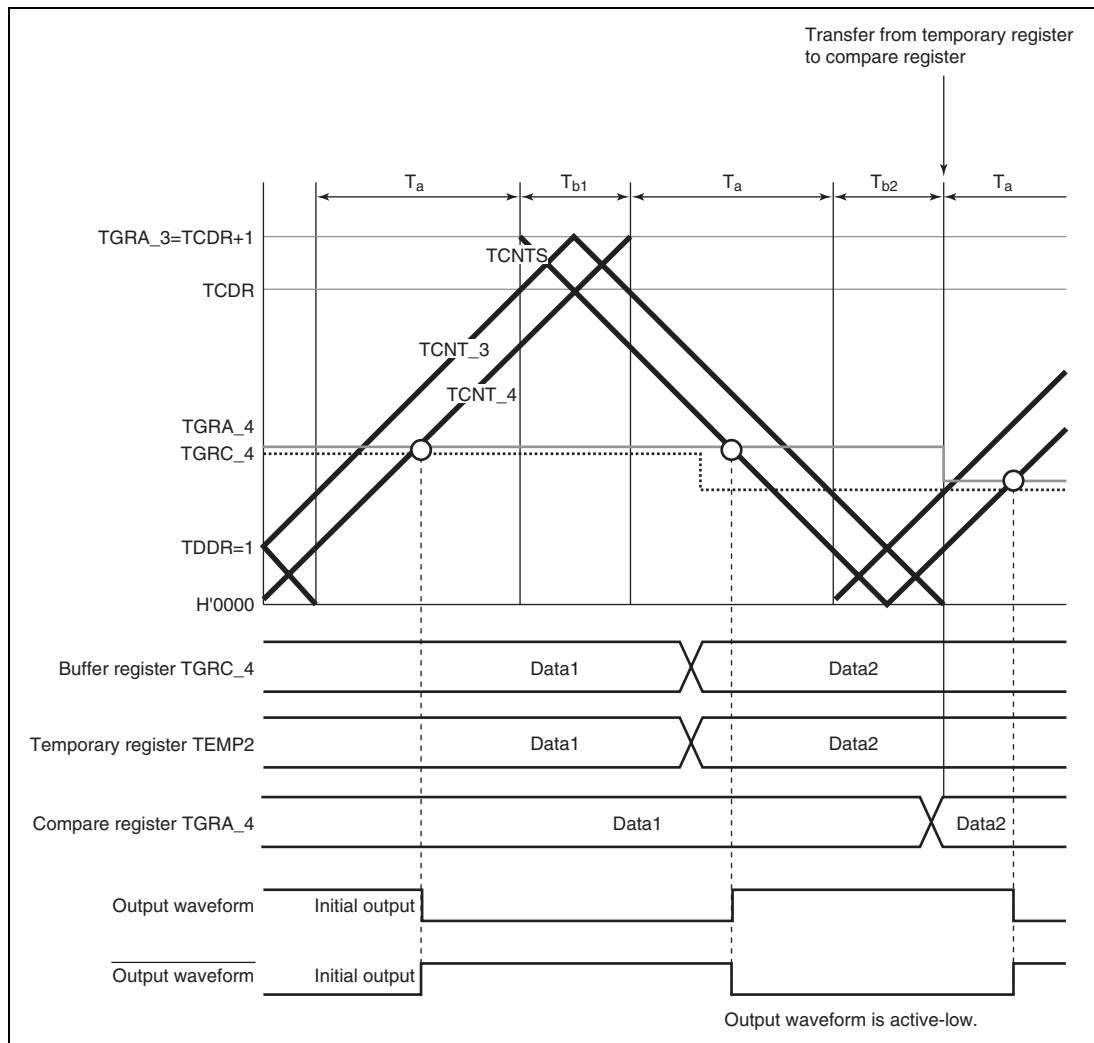

Figure 10.41 Example of Operation without Dead Time

7. PWM Cycle Setting

In complementary PWM mode, the PWM pulse cycle is set in two registers—TGRA_3, in which the TCNT_3 upper limit value is set, and TCDR, in which the TCNT_4 upper limit value is set. The settings should be made so as to achieve the following relationship between these two registers:

With dead time: TGRA_3 set value = TCDR set value + TDDR set value

Without dead time: TGRA_3 set value = TCDR set value + 1

The TGRA_3 and TCDR settings are made by setting the values in buffer registers TGRC_3 and TCBR. The values set in TGRC_3 and TCBR are transferred simultaneously to TGRA_3 and TCDR in accordance with the transfer timing selected with bits MD3 to MD0 in the timer mode register (TMDR).

The updated PWM cycle is reflected from the next cycle when the data update is performed at the crest, and from the current cycle when performed in the trough. Figure 10.42 illustrates the operation when the PWM cycle is updated at the crest.

See the following section, Register Data Updating, for the method of updating the data in each buffer register.

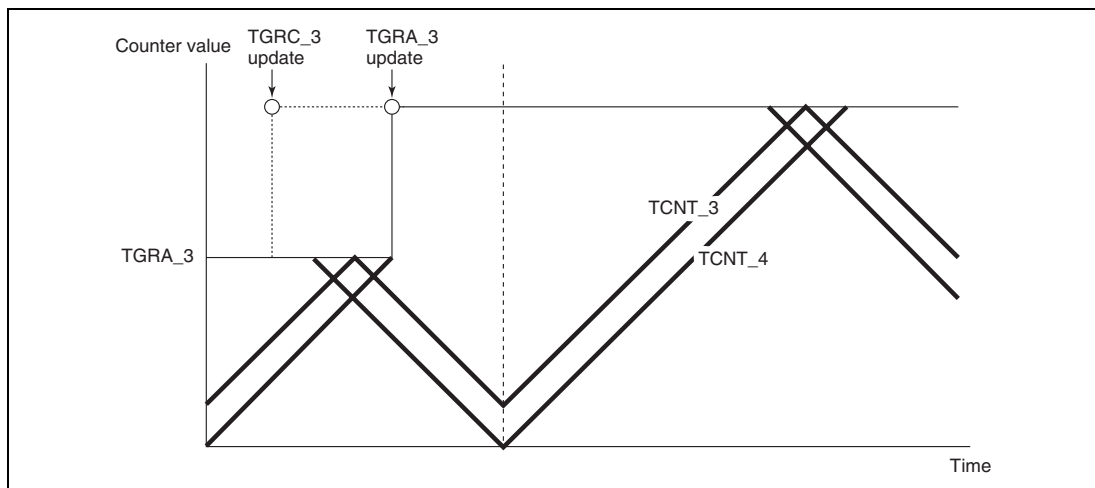

Figure 10.42 Example of PWM Cycle Updating

8. Register Data Updating

In complementary PWM mode, the buffer register is used to update the data in a compare register. The update data can be written to the buffer register at any time. There are five PWM duty and carrier cycle registers that have buffer registers and can be updated during operation.

There is a temporary register between each of these registers and its buffer register. When subcounter TCNTS is not counting, if buffer register data is updated, the temporary register value is also rewritten. Transfer is not performed from buffer registers to temporary registers when TCNTS is counting; in this case, the value written to a buffer register is transferred after TCNTS halts.

The temporary register value is transferred to the compare register at the data update timing set with bits MD3 to MD0 in the timer mode register (TMDR). Figure 10.43 shows an example of data updating in complementary PWM mode. This example shows the mode in which data updating is performed at both the counter crest and trough.

When rewriting buffer register data, a write to TGRD_4 must be performed at the end of the update. Data transfer from the buffer registers to the temporary registers is performed simultaneously for all five registers after the write to TGRD_4.

A write to TGRD_4 must be performed after writing data to the registers to be updated, even when not updating all five registers, or when updating the TGRD_4 data. In this case, the data written to TGRD_4 should be the same as the data prior to the write operation.

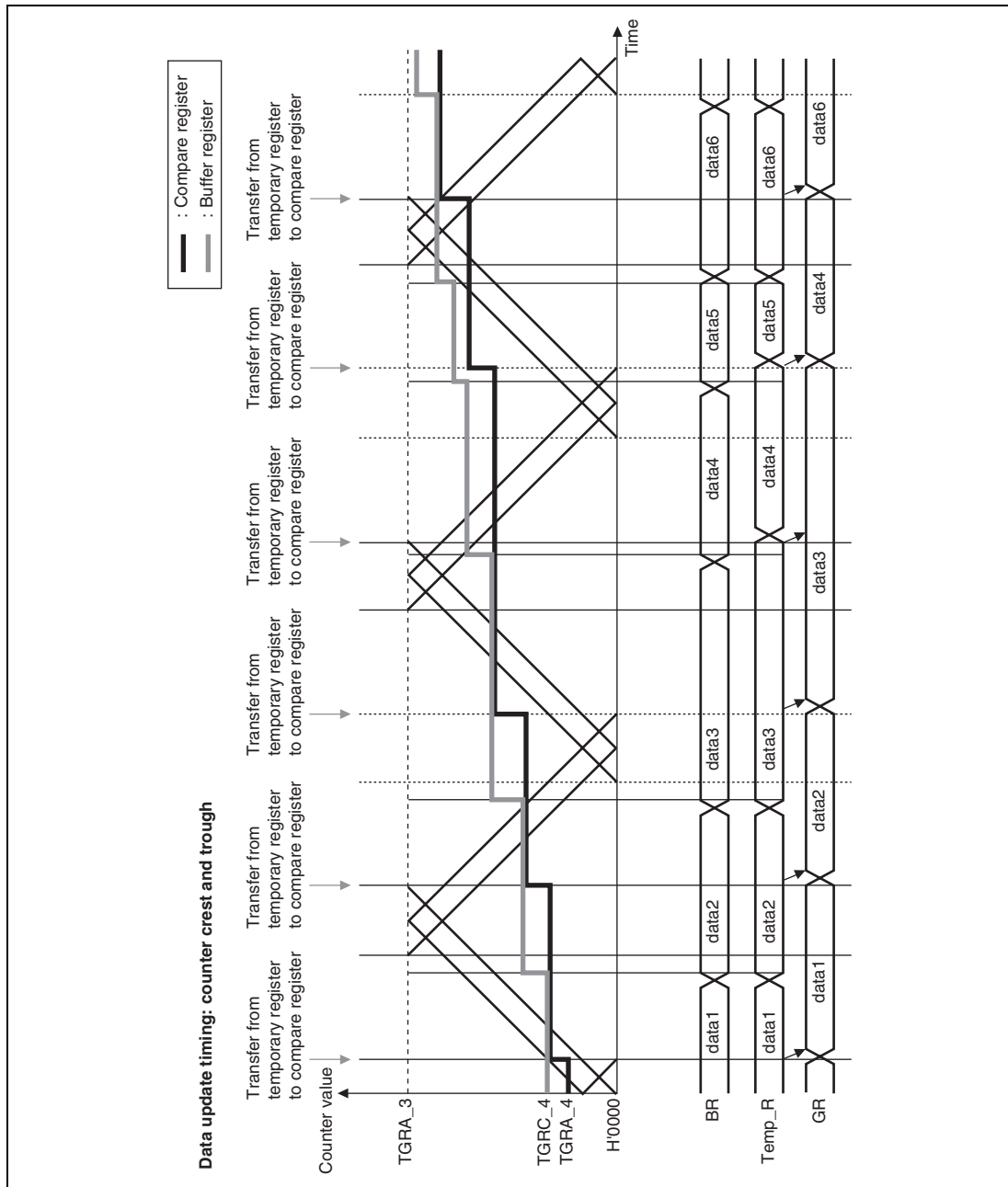

Figure 10.43 Example of Data Update in Complementary PWM Mode

9. Initial Output in Complementary PWM Mode

In complementary PWM mode, the initial output is determined by the setting of bits OLSN and OLSP in timer output control register 1 (TOCR1) or bits OLS1N to OLS3N and OLS1P to OLS3P in timer output control register 2 (TOCR2).

This initial output is the PWM pulse non-active level, and is output from when complementary PWM mode is set with the timer mode register (TMDR) until TCNT_4 exceeds the value set in the dead time register (TDDR). Figure 10.44 shows an example of the initial output in complementary PWM mode.

An example of the waveform when the initial PWM duty value is smaller than the TDDR value is shown in figure 10.45.

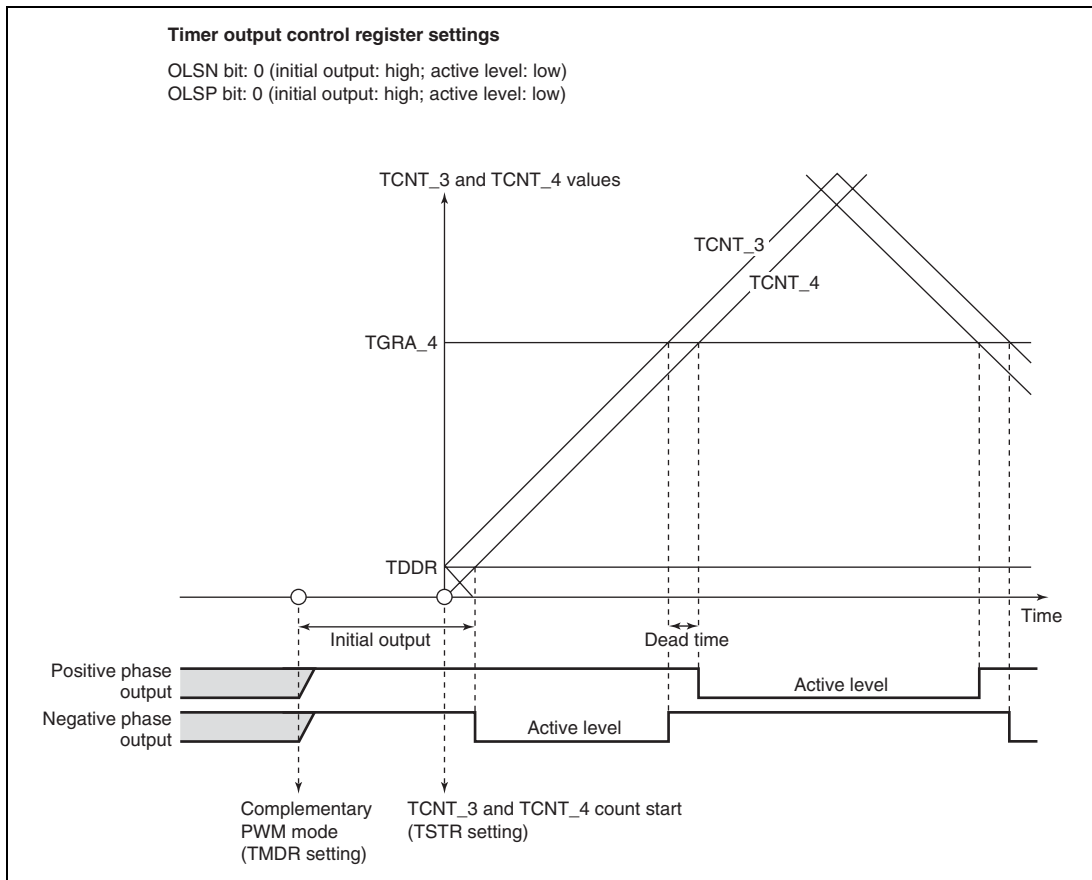

Figure 10.44 Example of Initial Output in Complementary PWM Mode (1)

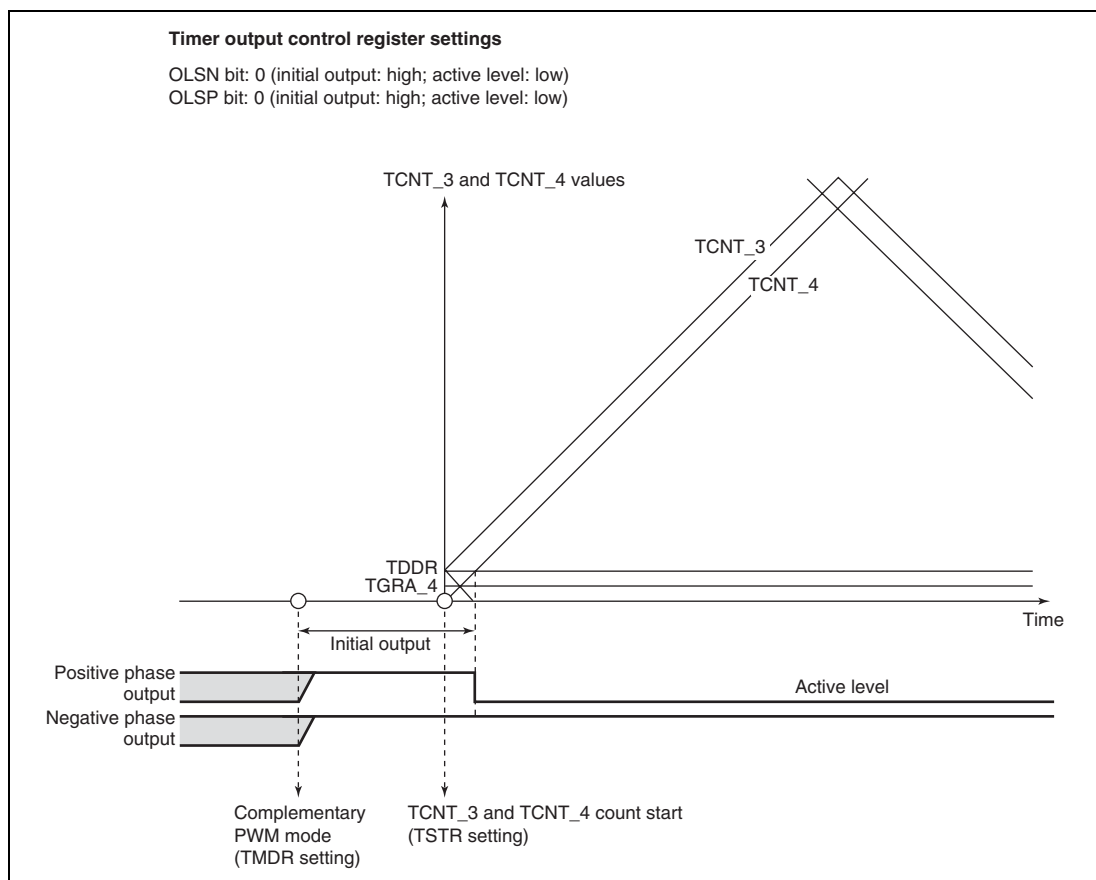

Figure 10.45 Example of Initial Output in Complementary PWM Mode (2)

10. Complementary PWM Mode PWM Output Generation Method

In complementary PWM mode, 3-phase output is performed of PWM waveforms with a non-overlap time between the positive and negative phases. This non-overlap time is called the dead time.

A PWM waveform is generated by output of the output level selected in the timer output control register in the event of a compare-match between a counter and data register. While TCNTS is counting, data register and temporary register values are simultaneously compared to create consecutive PWM pulses from 0 to 100%. The relative timing of on and off compare-match occurrence may vary, but the compare-match that turns off each phase takes precedence to secure the dead time and ensure that the positive phase and negative phase on times do not overlap. Figures 10.46 to 10.48 show examples of waveform generation in complementary PWM mode.

The positive phase/negative phase off timing is generated by a compare-match with the solid-line counter, and the on timing by a compare-match with the dotted-line counter operating with a delay of the dead time behind the solid-line counter. In the T1 period, compare-match **a** that turns off the negative phase has the highest priority, and compare-matches occurring prior to **a** are ignored. In the T2 period, compare-match **c** that turns off the positive phase has the highest priority, and compare-matches occurring prior to **c** are ignored.

In normal cases, compare-matches occur in the order **a** → **b** → **c** → **d** (or **c** → **d** → **a'** → **b'**), as shown in figure 10.46.

If compare-matches deviate from the **a** → **b** → **c** → **d** order, since the time for which the negative phase is off is less than twice the dead time, the figure shows the positive phase is not being turned on. If compare-matches deviate from the **c** → **d** → **a'** → **b'** order, since the time for which the positive phase is off is less than twice the dead time, the figure shows the negative phase is not being turned on.

If compare-match **c** occurs first following compare-match **a**, as shown in figure 10.47, compare-match **b** is ignored, and the negative phase is turned off by compare-match **d**. This is because turning off of the positive phase has priority due to the occurrence of compare-match **c** (positive phase off timing) before compare-match **b** (positive phase on timing) (consequently, the waveform does not change since the positive phase goes from off to off).

Similarly, in the example in figure 10.48, compare-match **a'** with the new data in the temporary register occurs before compare-match **c**, but other compare-matches occurring up to **c**, which turns off the positive phase, are ignored. As a result, the negative phase is not turned on.

Thus, in complementary PWM mode, compare-matches at turn-off timings take precedence, and turn-on timing compare-matches that occur before a turn-off timing compare-match are ignored.

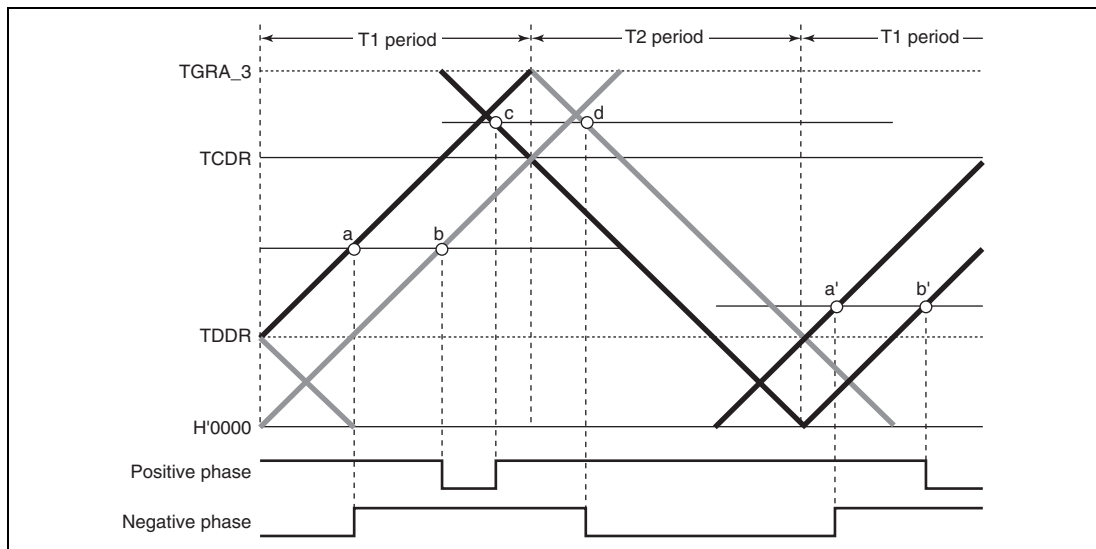

Figure 10.46 Example of Complementary PWM Mode Waveform Output (1)

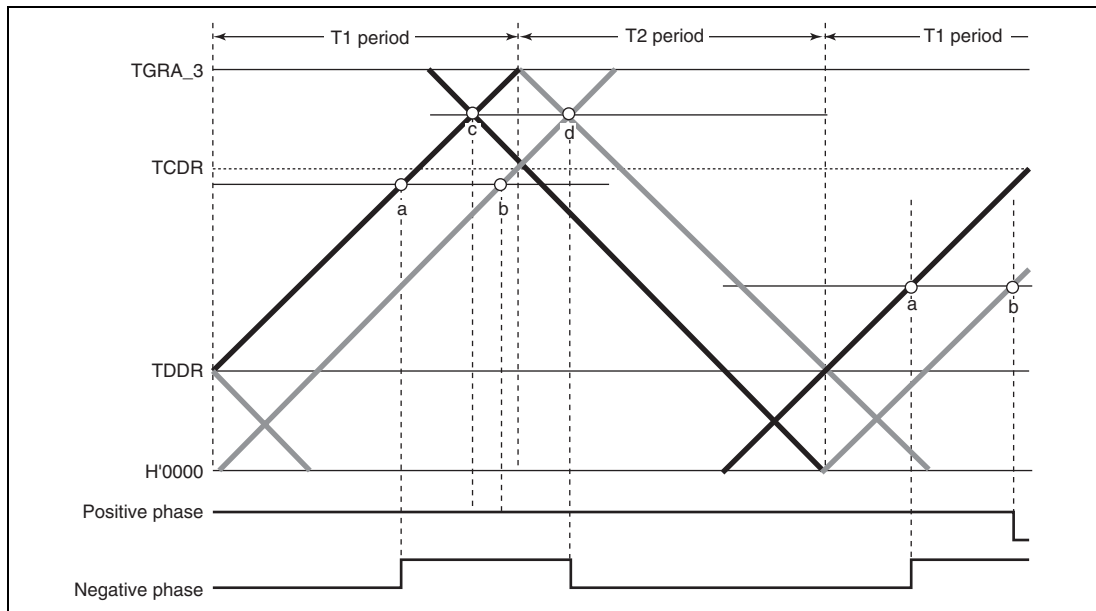

Figure 10.47 Example of Complementary PWM Mode Waveform Output (2)

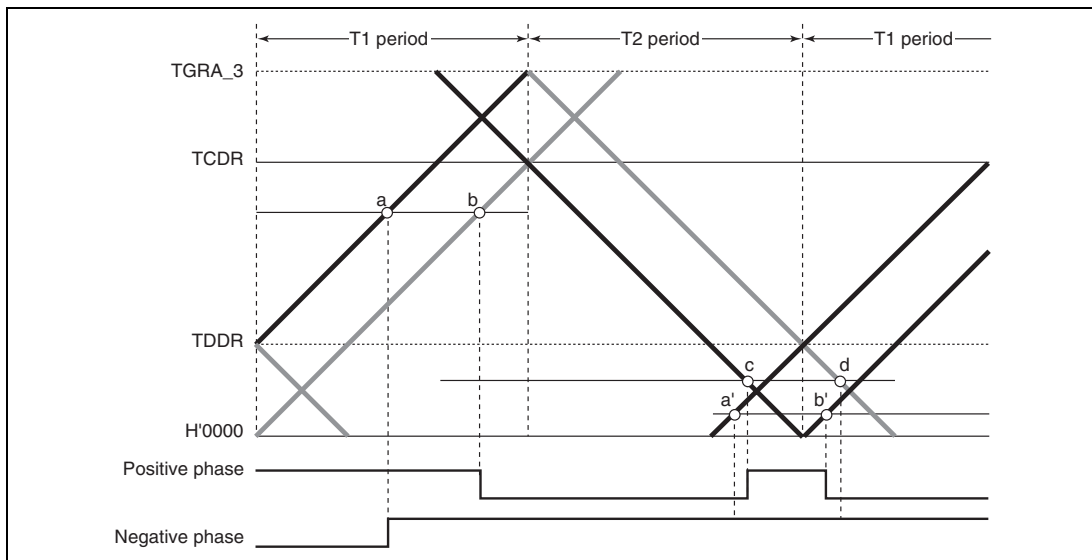

Figure 10.48 Example of Complementary PWM Mode Waveform Output (3)

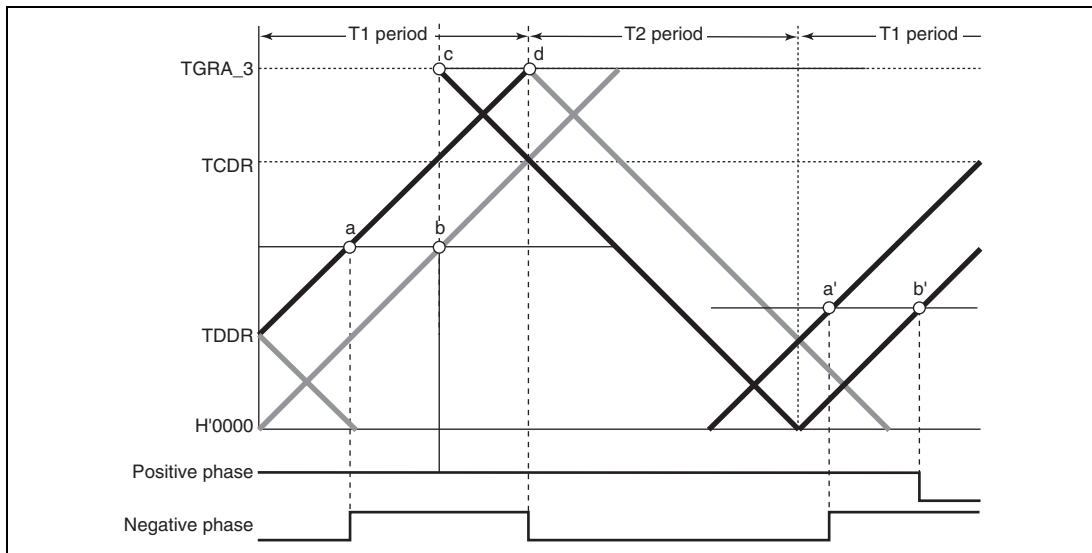

Figure 10.49 Example of Complementary PWM Mode 0% and 100% Waveform Output (1)

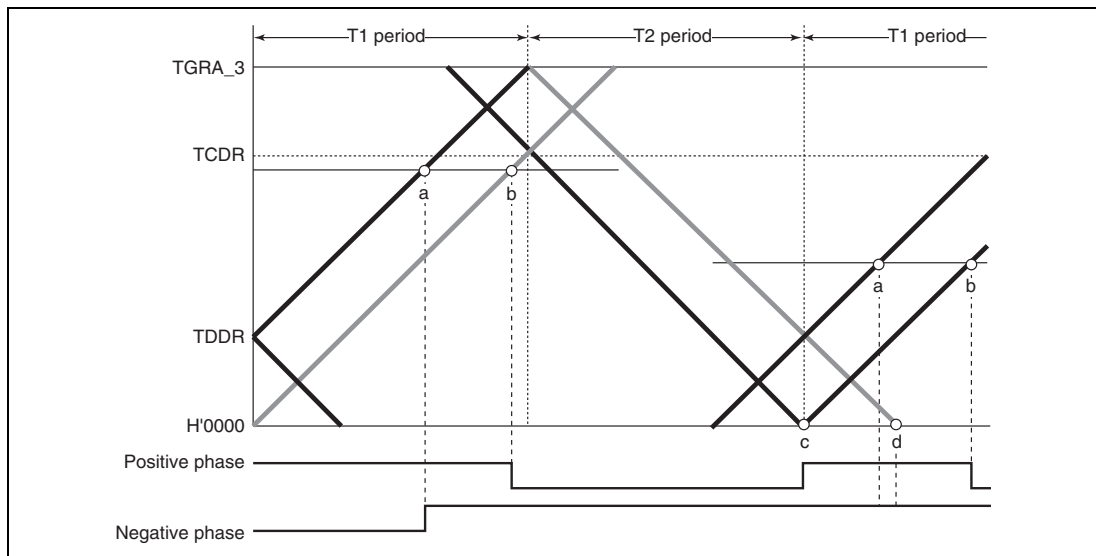

Figure 10.50 Example of Complementary PWM Mode 0% and 100% Waveform Output (2)

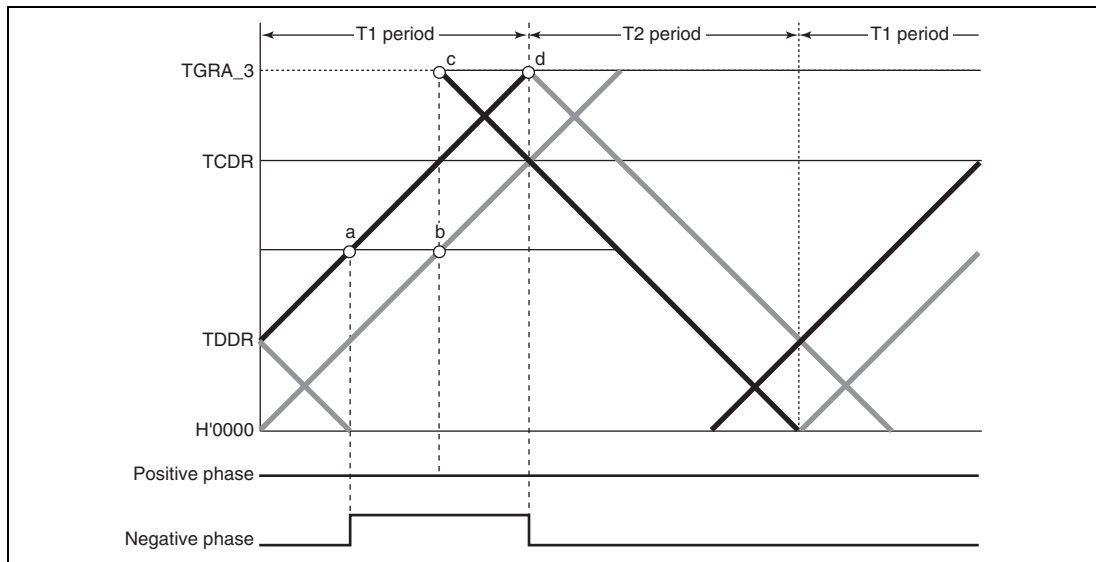

Figure 10.51 Example of Complementary PWM Mode 0% and 100% Waveform Output (3)

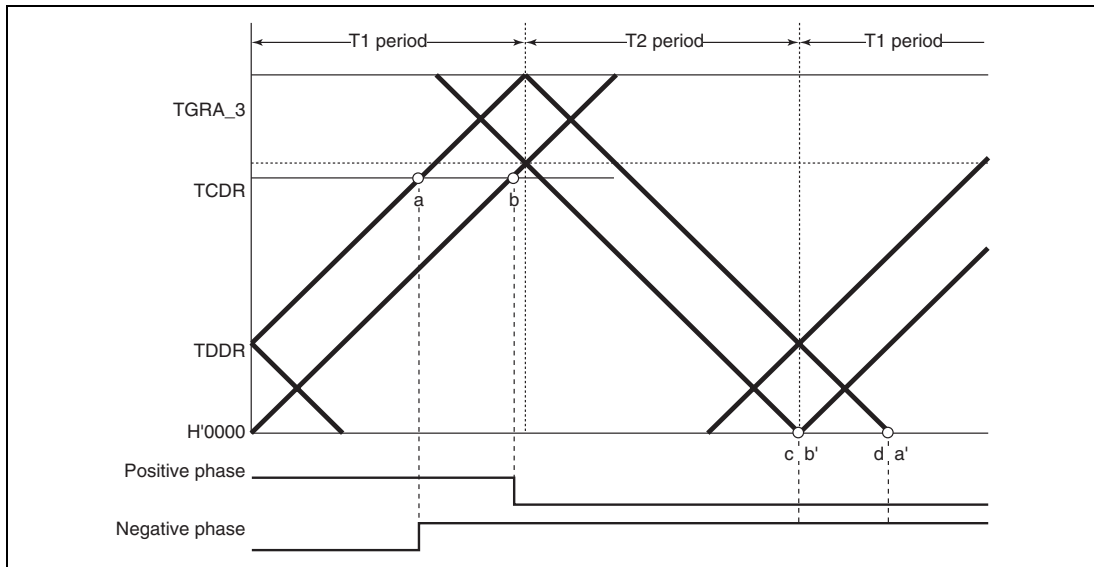

Figure 10.52 Example of Complementary PWM Mode 0% and 100% Waveform Output (4)

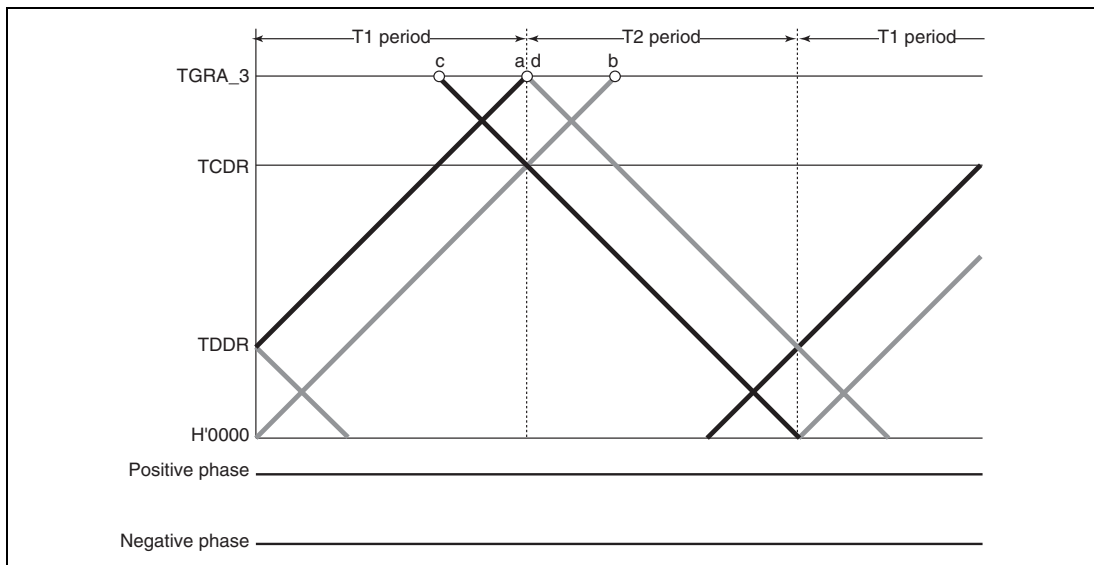

Figure 10.53 Example of Complementary PWM Mode 0% and 100% Waveform Output (5)

11. Complementary PWM Mode 0% and 100% Duty Output

In complementary PWM mode, 0% and 100% duty cycles can be output as required. Figures 10.49 to 10.53 show output examples.

100% duty output is performed when the data register value is set to H'0000. The waveform in this case has a positive phase with a 100% on-state. 0% duty output is performed when the data register value is set to the same value as TGRA_3. The waveform in this case has a positive phase with a 100% off-state.

On and off compare-matches occur simultaneously, but if a turn-on compare-match and turn-off compare-match for the same phase occur simultaneously, both compare-matches are ignored and the waveform does not change.

12. Toggle Output Synchronized with PWM Cycle

In complementary PWM mode, toggle output can be performed in synchronization with the PWM carrier cycle by setting the PSYE bit to 1 in the timer output control register (TOCR). An example of a toggle output waveform is shown in figure 10.54.

This output is toggled by a compare-match between TCNT_3 and TGRA_3 and a compare-match between TCNT4 and H'0000.

The output pin for this toggle output is the TIOC3A pin. The initial output is 1.

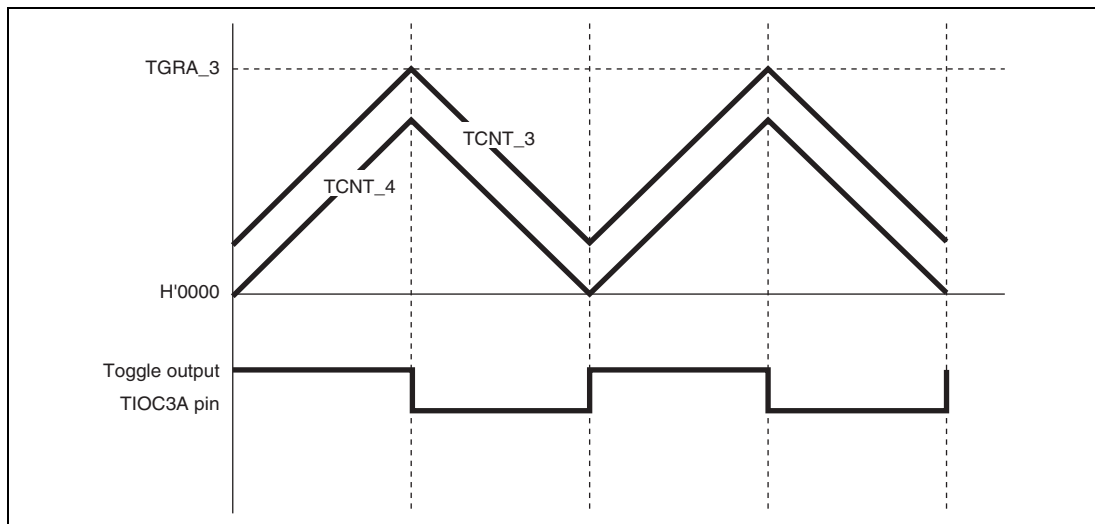

Figure 10.54 Example of Toggle Output Waveform Synchronized with PWM Output

13. Counter Clearing by Another Channel

In complementary PWM mode, by setting a mode for synchronization with another channel by means of the timer synchronous register (TSYR), and selecting synchronous clearing with bits CCLR2 to CCLR0 in the timer control register (TCR), it is possible to have TCNT_3, TCNT_4, and TCNTS cleared by another channel.

Figure 10.55 illustrates the operation.

Use of this function enables counter clearing and restarting to be performed by means of an external signal.

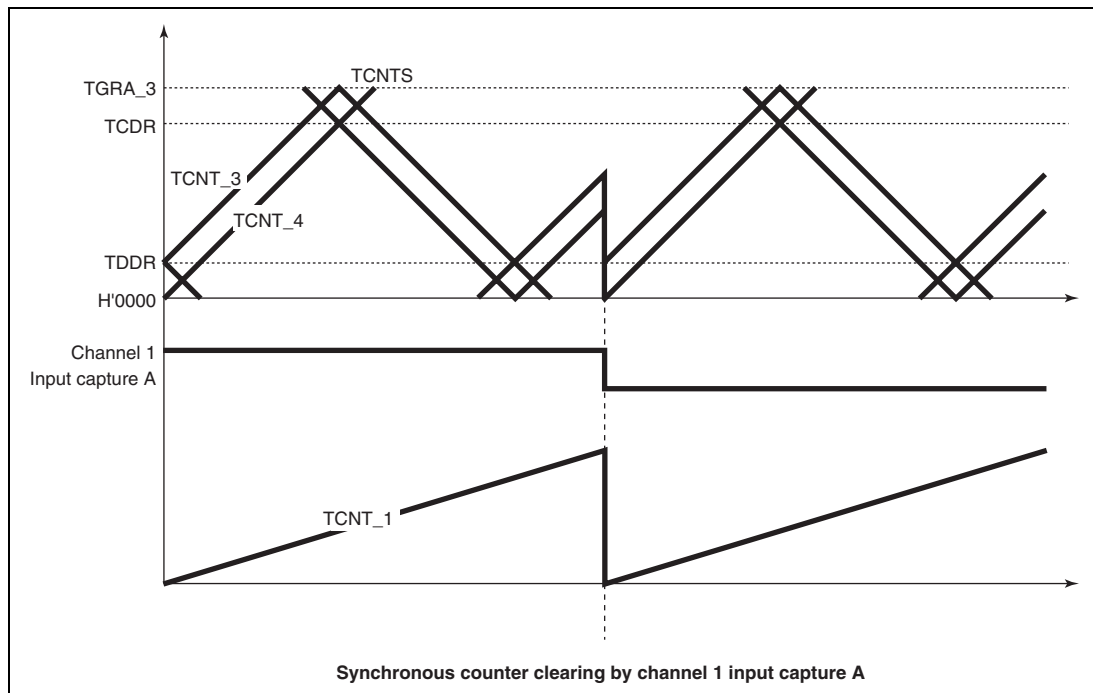

Figure 10.55 Counter Clearing Synchronized with Another Channel

14. Output Waveform Control at Synchronous Counter Clearing in Complementary PWM Mode

Setting the WRE bit in TWCR to 1 suppresses initial output when synchronous counter clearing occurs in the T_b interval at the trough in complementary PWM mode and controls abrupt change in duty cycle at synchronous counter clearing.

Initial output suppression is applicable only when synchronous clearing occurs in the T_b interval at the trough as indicated by (10) or (11) in figure 10.56. When synchronous clearing occurs outside that interval, the initial value specified by the OLS bits in TOCR is output. Even in the T_b interval at the trough, if synchronous clearing occurs in the initial value output period (indicated by (1) in figure 10.56) immediately after the counters start operation, initial value output is not suppressed.

When using the initial output suppression function, make sure to set compare registers TGRB_3, TGRA_4, and TGRB_4 to a value twice or more the setting of dead time data register TDDR. If synchronous clearing occurs with the compare registers set to a value less than twice the setting of TDDR, the PWM output dead time may be too short (or nonexistent) or illegal active-level PWM negative-phase output may occur during the initial output suppression interval. For details, see 10.7.23, Notes on Output Waveform Control During Synchronous Counter Clearing in Complementary PWM Mode.

This function can be used in both the MTU2 and MTU2S. In the MTU2, synchronous clearing generated in channels 0 to 2 in the MTU2 can cause counter clearing in complementary PWM mode; in the MTU2S, compare match or input capture flag setting in channels 0 to 2 in the MTU2 can cause counter clearing.

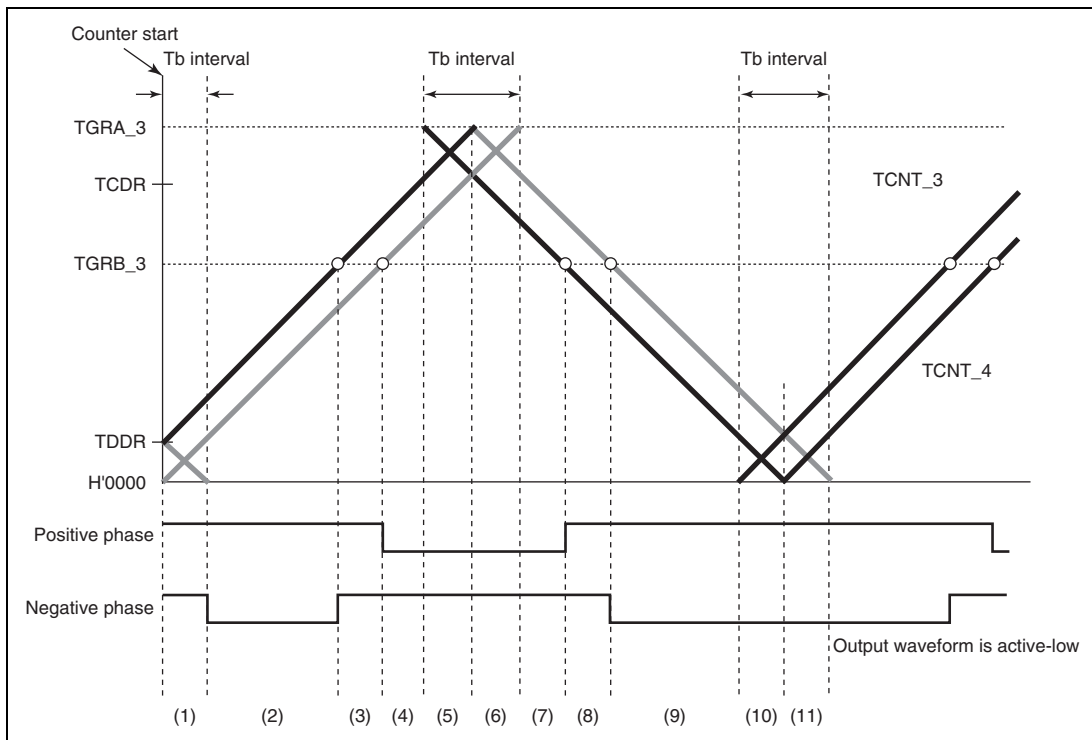

Figure 10.56 Timing for Synchronous Counter Clearing

— Example of Procedure for Setting Output Waveform Control at Synchronous Counter Clearing in Complementary PWM Mode

An example of the procedure for setting output waveform control at synchronous counter clearing in complementary PWM mode is shown in figure 10.57.

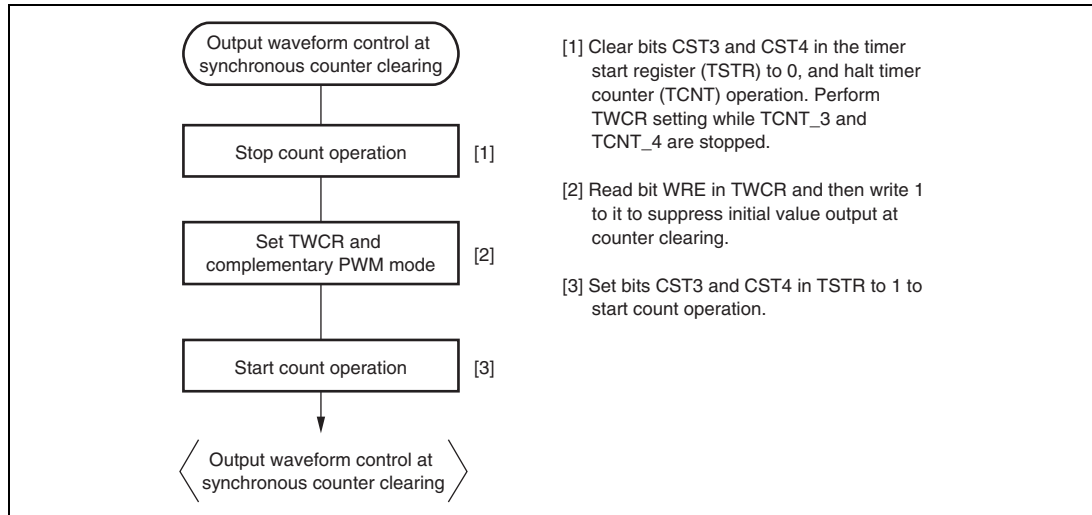

Figure 10.57 Example of Procedure for Setting Output Waveform Control at Synchronous Counter Clearing in Complementary PWM Mode

— Examples of Output Waveform Control at Synchronous Counter Clearing in Complementary PWM Mode

Figures 10.58 to 10.61 show examples of output waveform control in which the MTU2 operates in complementary PWM mode and synchronous counter clearing is generated while the WRE bit in TWCR is set to 1. In the examples shown in figures 10.58 to 10.61, synchronous counter clearing occurs at timing (3), (6), (8), and (11) shown in figure 10.56, respectively.

In the MTU2S, these examples are equivalent to the cases when the MTU2S operates in complementary PWM mode and synchronous counter clearing is generated while the SCC bit is cleared to 0 and the WRE bit is set to 1 in TWCR.

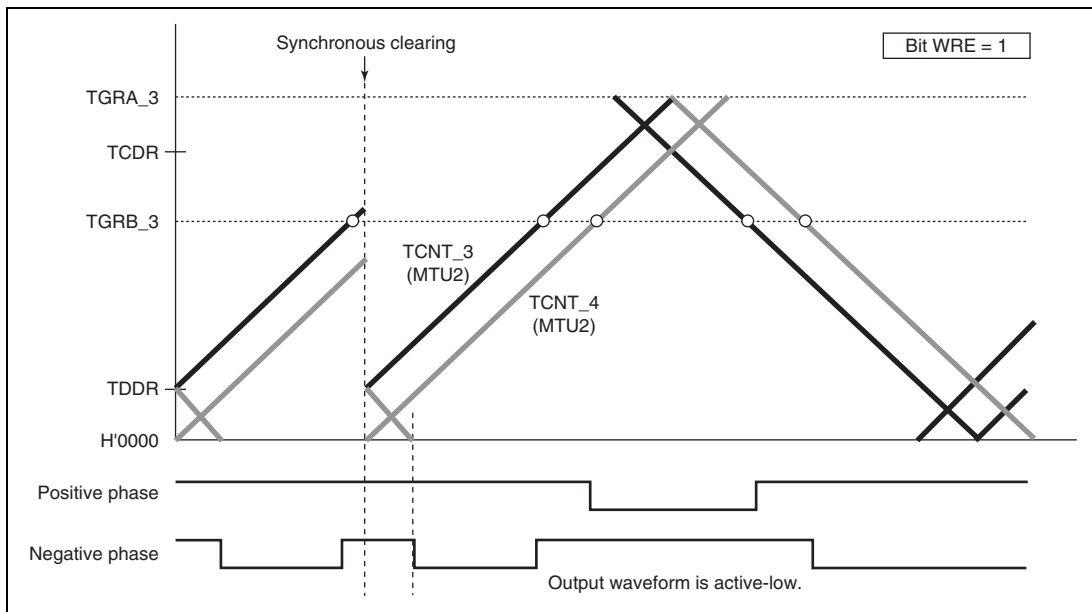

Figure 10.58 Example of Synchronous Clearing in Dead Time during Up-Counting (Timing (3) in Figure 10.56; Bit WRE of TWCR in MTU2 Is 1)

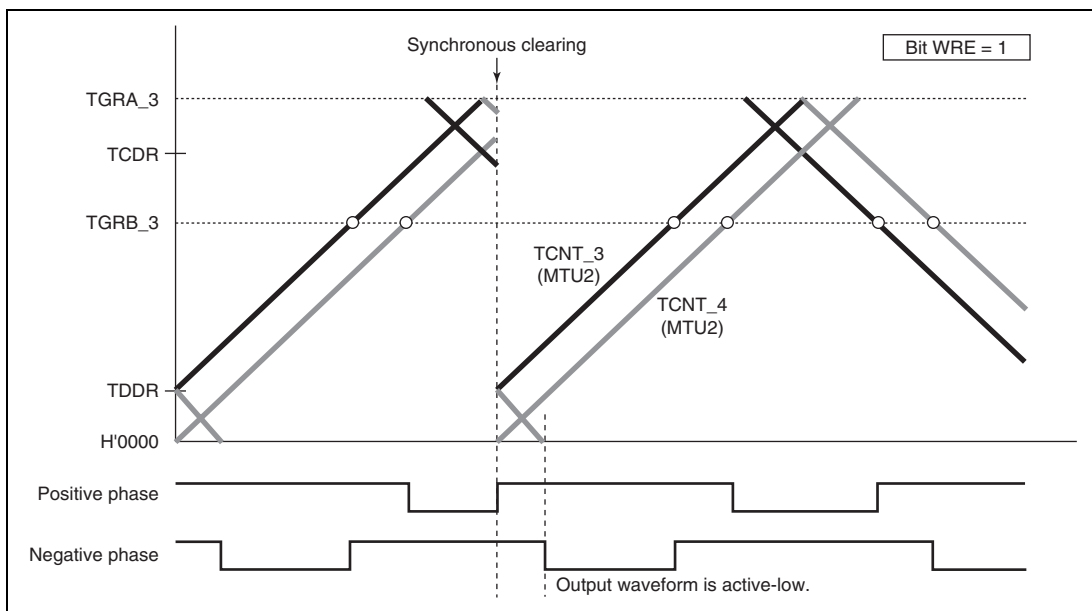

Figure 10.59 Example of Synchronous Clearing in Interval Tb at Crest (Timing (6) in Figure 10.56; Bit WRE of TWCR in MTU2 Is 1)

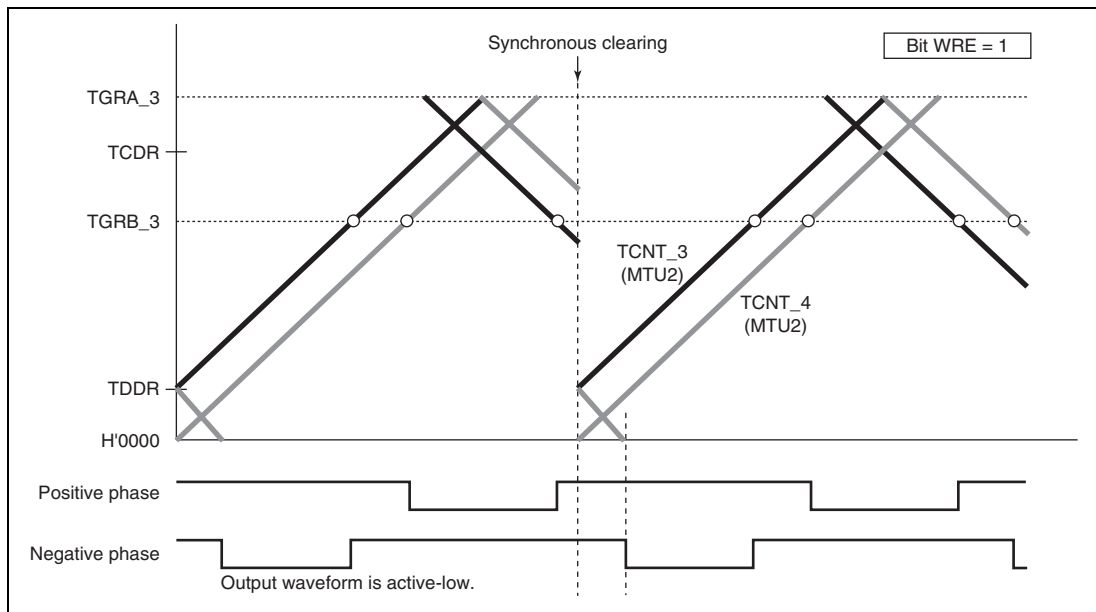
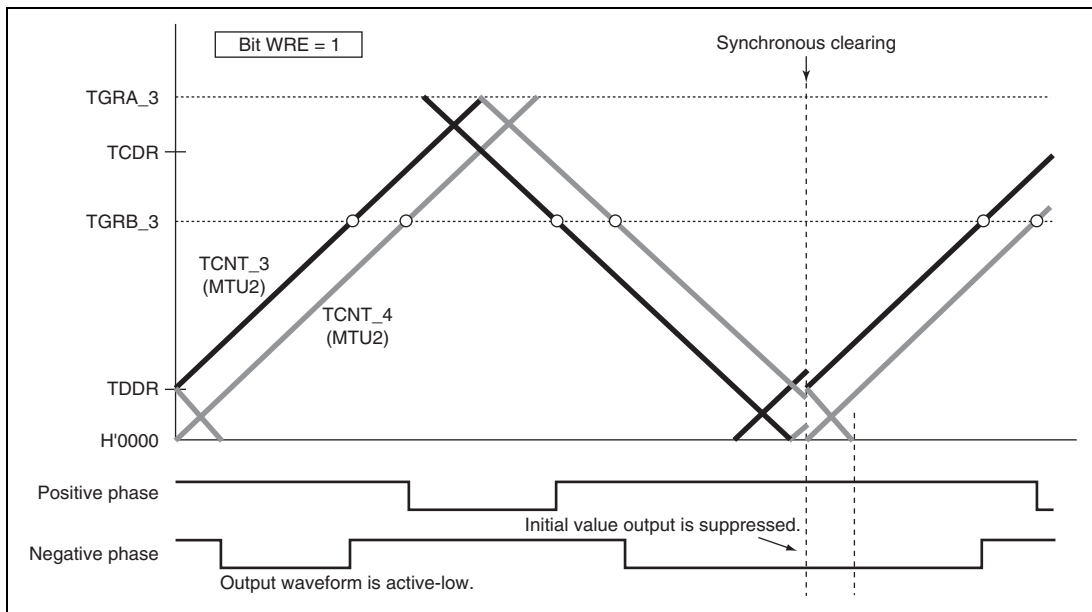

Figure 10.60 Example of Synchronous Clearing in Dead Time during Down-Counting (Timing (8) in Figure 10.56; Bit WRE of TWCR Is 1)



**Figure 10.61 Example of Synchronous Clearing in Interval Tb at Trough
(Timing (11) in Figure 10.56; Bit WRE of TWCR Is 1)**

15. Suppressing MTU2–MTU2S Synchronous Counter Clearing

In the MTU2S, setting the SCC bit in TWCR to 1 suppresses synchronous counter clearing caused by the MTU2.

Synchronous counter clearing is suppressed only within the interval shown in figure 10.62.

When using this function, the MTU2S should be set to complementary PWM mode.

For details of synchronous clearing caused by the MTU2, refer to the description about MTU2S counter clearing caused by MTU2 flag setting source (MTU2–MTU2S synchronous counter clearing) in section 10.4.10, MTU2–MTU2S Synchronous Operation.

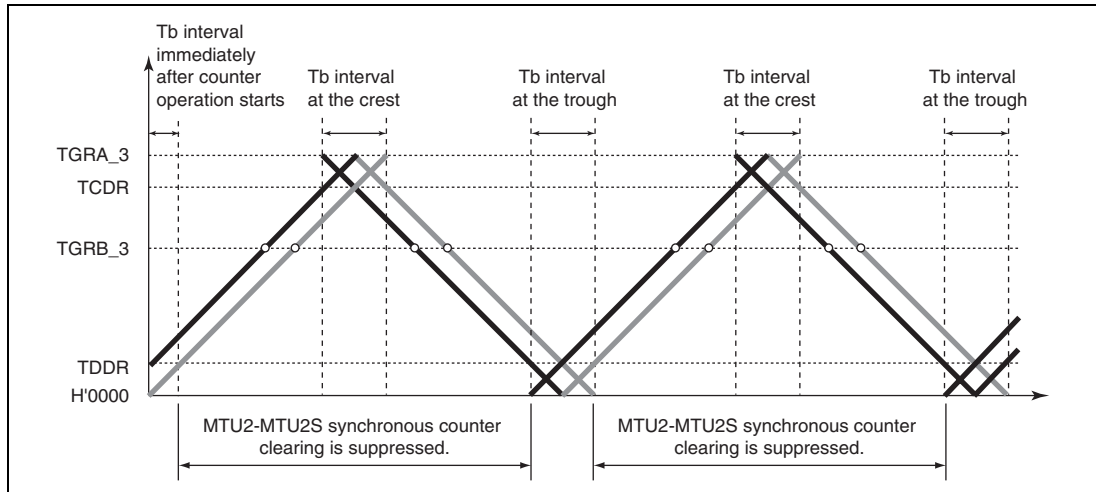

Figure 10.62 MTU2–MTU2S Synchronous Clearing-Suppressed Interval Specified by SCC Bit in TWCR

— Example of Procedure for Suppressing MTU2–MTU2S Synchronous Counter Clearing
An example of the procedure for suppressing MTU2–MTU2S synchronous counter clearing is shown in figure 10.63.

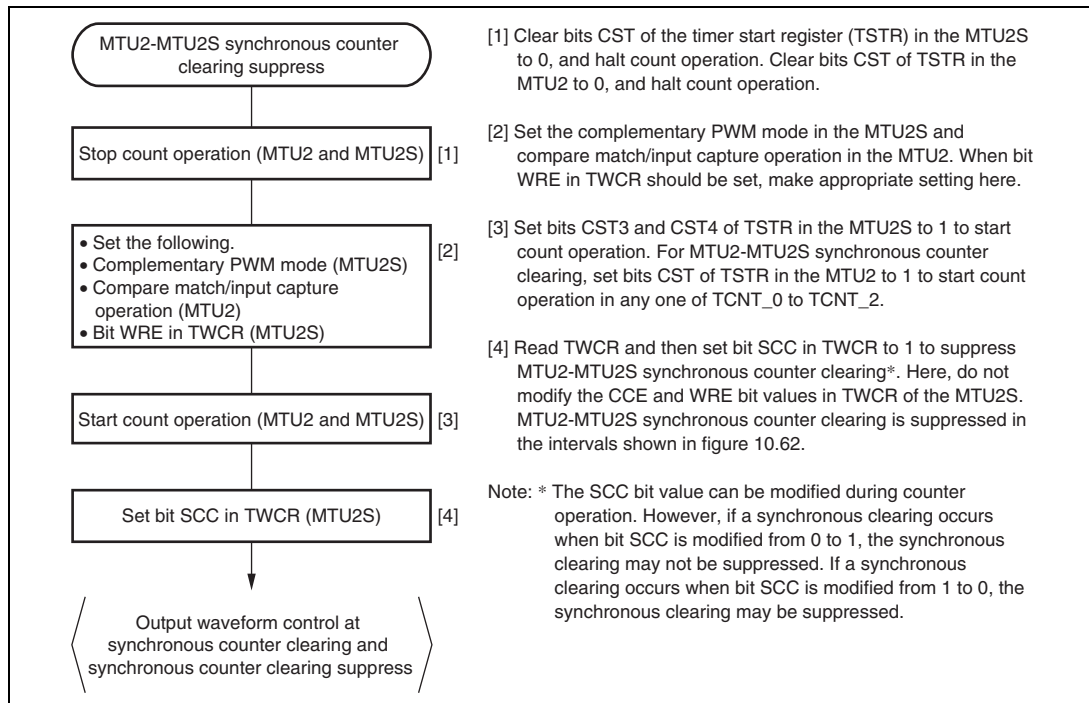

Figure 10.63 Example of Procedure for Suppressing MTU2–MTU2S Synchronous Counter Clearing

— Examples of Suppression of MTU2–MTU2S Synchronous Counter Clearing

Figures 10.64 to 10.67 show examples of operation in which the MTU2S operates in complementary PWM mode and MTU2–MTU2S synchronous counter clearing is suppressed by setting the SCC bit in TWCR in the MTU2S to 1. In the examples shown in figures 10.64 to 10.67, synchronous counter clearing occurs at timing (3), (6), (8), and (11) shown in figure 10.56, respectively.

In these examples, the WRE bit in TWCR of the MTU2S is set to 1.

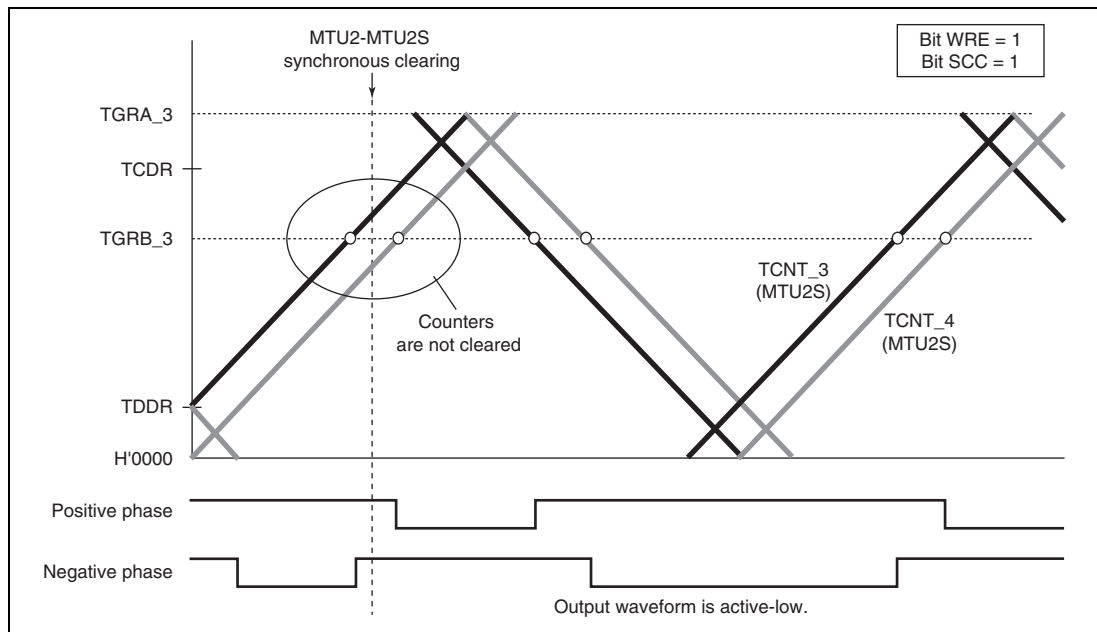
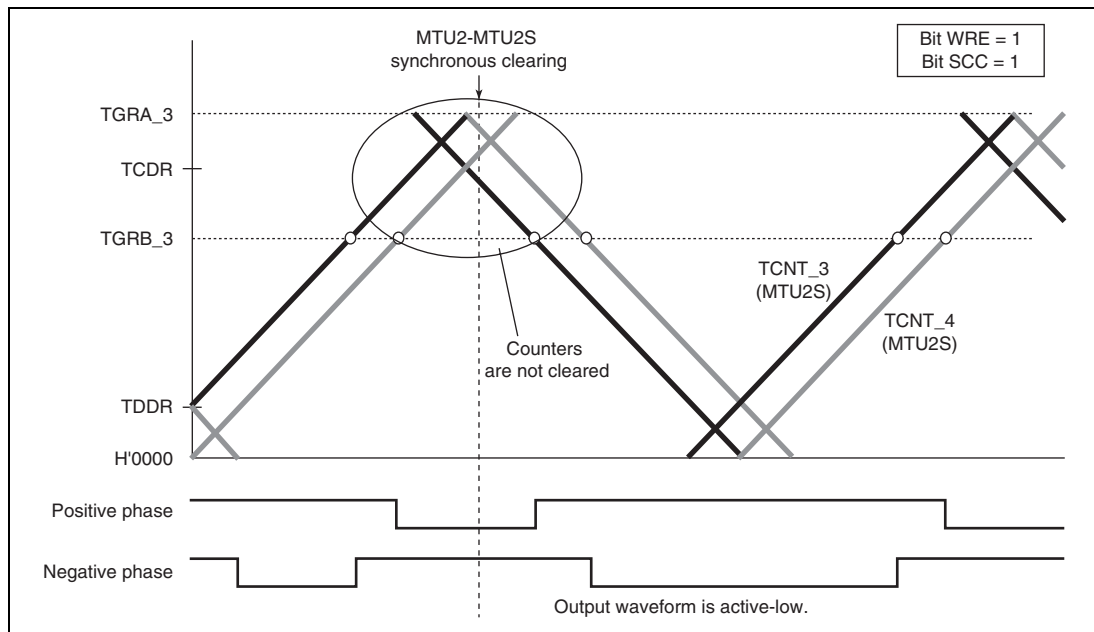

Figure 10.64 Example of Synchronous Clearing in Dead Time during Up-Counting (Timing (3) in Figure 10.56; Bit WRE Is 1 and Bit SCC Is 1 in TWCR of MTU2S)



**Figure 10.65 Example of Synchronous Clearing in Interval Tb at Crest
(Timing (6) in Figure 10.56; Bit WRE Is 1 and Bit SCC Is 1 in TWCR of MTU2S)**

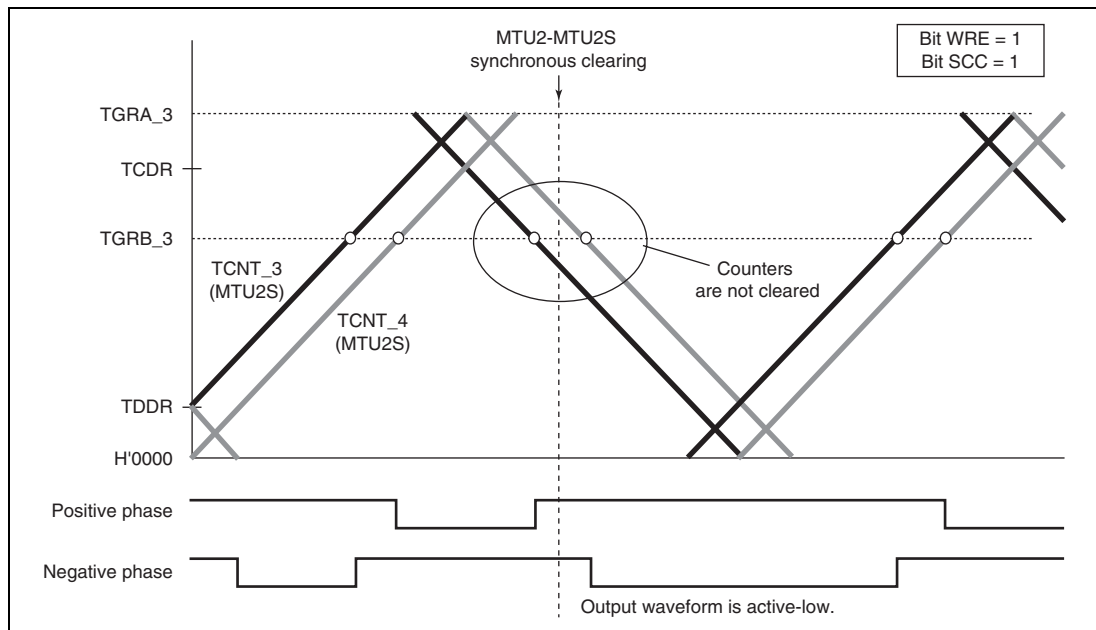

Figure 10.66 Example of Synchronous Clearing in Dead Time during Down-Counting (Timing (8) in Figure 10.56; Bit WRE Is 1 and Bit SCC Is 1 in TWCR of MTU2S)

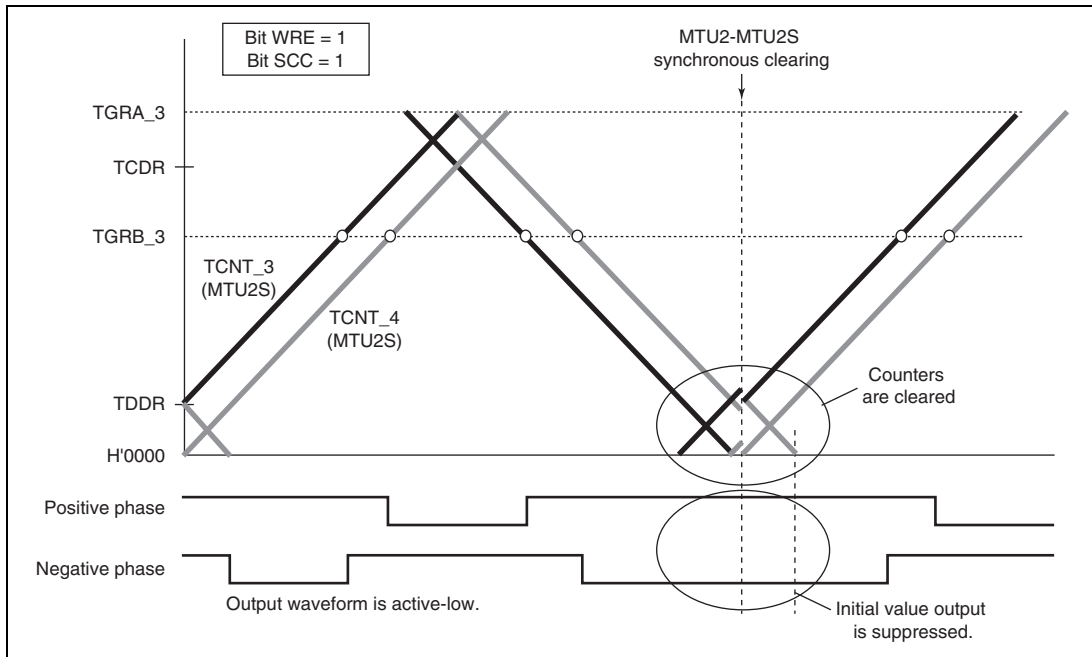

Figure 10.67 Example of Synchronous Clearing in Interval Tb at Trough (Timing (11) in Figure 10.56; Bit WRE Is 1 and Bit SCC Is 1 in TWCR of MTU2S)

16. Counter Clearing by TGRA_3 Compare Match

In complementary PWM mode, by setting the CCE bit in the timer waveform control register (TWCR), it is possible to have TCNT_3, TCNT_4, and TCNTS cleared by TGRA_3 compare match.

Figure 10.68 illustrates an operation example.

- Notes:
1. Use this function only in complementary PWM mode 1 (transfer at crest)
 2. Do not specify synchronous clearing by another channel (do not set the SYNC0 to SYNC4 bits in the timer synchronous register (TSYR) to 1 or the CE0A, CE0B, CE0C, CE0D, CE1A, CE1B, CE1C, and CE1D bits in the timer synchronous clear register (TSYCR) to 1).
 3. Do not set the PWM duty value to H'0000.
 4. Do not set the PSYE bit in timer output control register 1 (TOCR1) to 1.

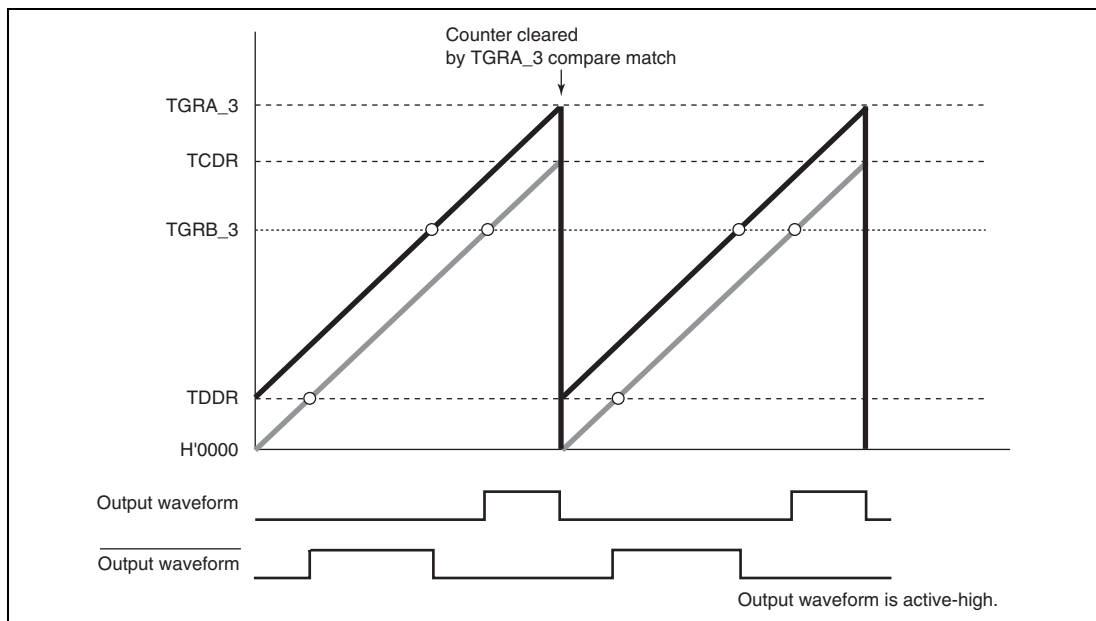

Figure 10.68 Example of Counter Clearing Operation by TGRA_3 Compare Match

17. Example of AC Synchronous Motor (Brushless DC Motor) Drive Waveform Output

In complementary PWM mode, a brushless DC motor can easily be controlled using the timer gate control register (TGCR). Figures 10.69 to 10.72 show examples of brushless DC motor drive waveforms created using TGCR.

When output phase switching for a 3-phase brushless DC motor is performed by means of external signals detected with a Hall element, etc., clear the FB bit in TGCR to 0. In this case, the external signals indicating the polarity position are input to channel 0 timer input pins TIOC0A, TIOC0B, and TIOC0C (set with PFC). When an edge is detected at pin TIOC0A, TIOC0B, or TIOC0C, the output on/off state is switched automatically.

When the FB bit is 1, the output on/off state is switched when the UF, VF, or WF bit in TGCR is cleared to 0 or set to 1.

The drive waveforms are output from the complementary PWM mode 6-phase output pins. With this 6-phase output, in the case of on output, it is possible to use complementary PWM mode output and perform chopping output by setting the N bit or P bit to 1. When the N bit or P bit is 0, level output is selected.

The 6-phase output active level (on output level) can be set with the OLSN and OLSP bits in the timer output control register (TOCR) regardless of the setting of the N and P bits.

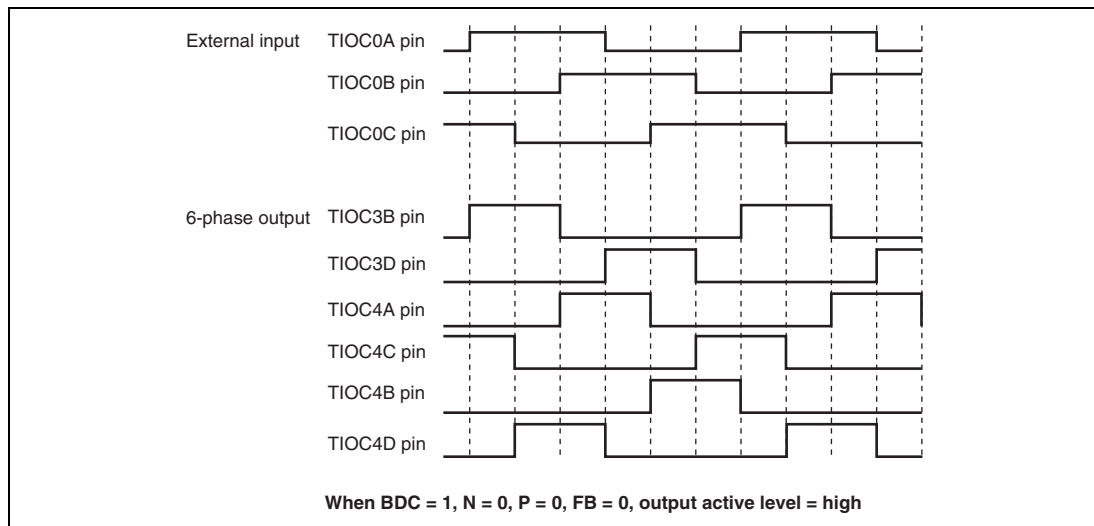

Figure 10.69 Example of Output Phase Switching by External Input (1)

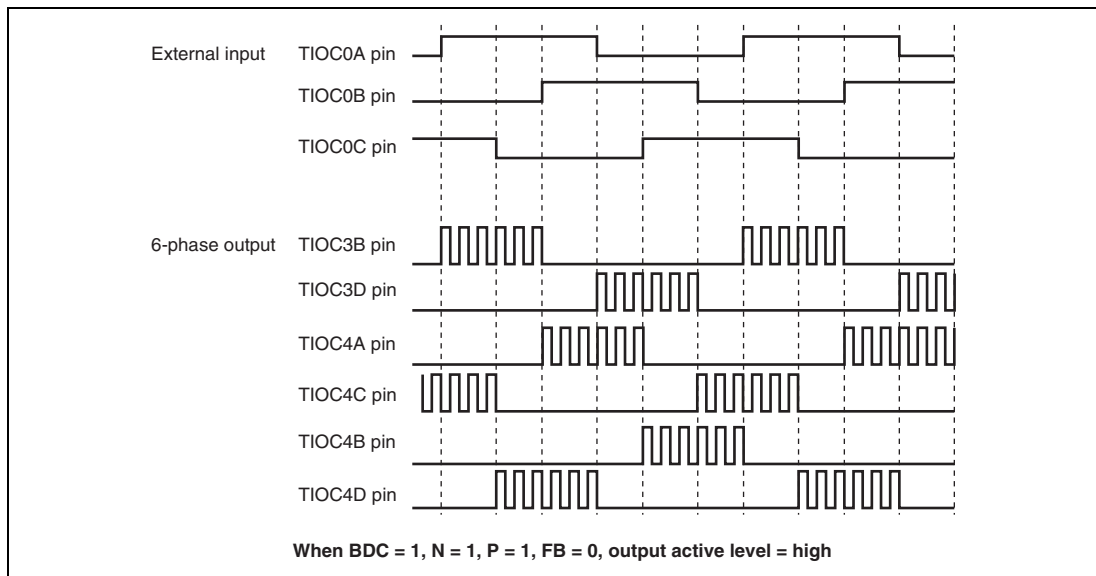

Figure 10.70 Example of Output Phase Switching by External Input (2)

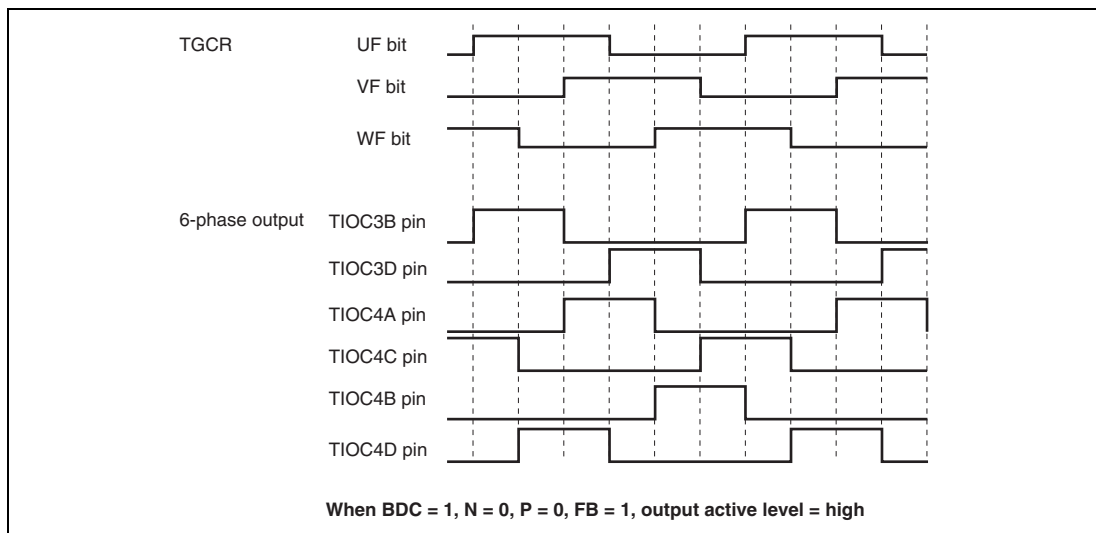

Figure 10.71 Example of Output Phase Switching by Means of UF, VF, WF Bit Settings (1)

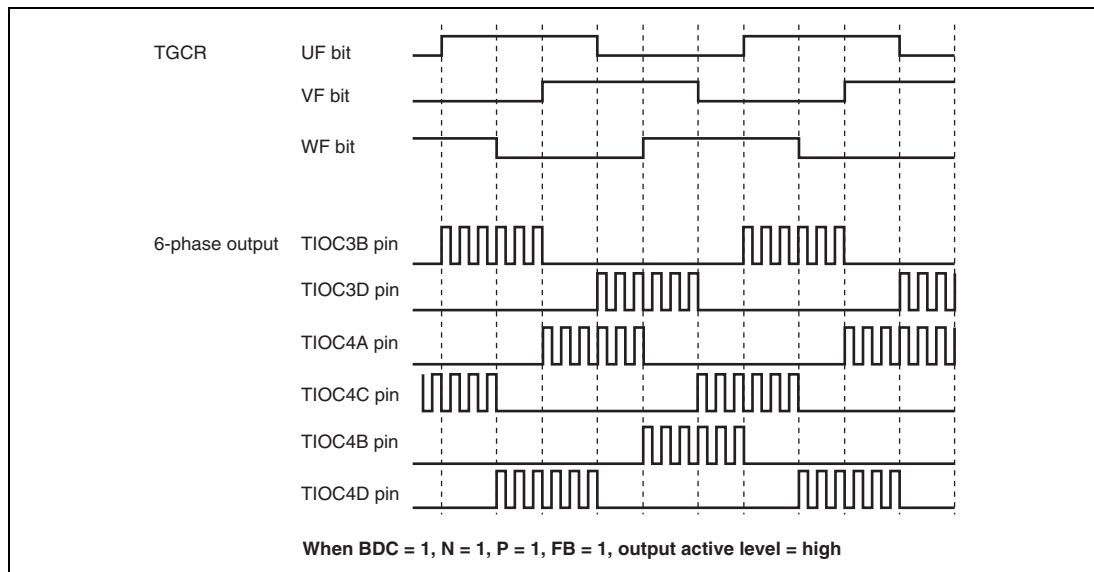

Figure 10.72 Example of Output Phase Switching by Means of UF, VF, WF Bit Settings (2)

18. A/D Converter Start Request Setting

In complementary PWM mode, an A/D converter start request can be issued using a TGRA_3 compare-match, TCNT_4 underflow (trough), or compare-match on a channel other than channels 3 and 4.

When start requests using a TGRA_3 compare-match are specified, A/D conversion can be started at the crest of the TCNT_3 count.

A/D converter start requests can be set by setting the TTGE bit to 1 in the timer interrupt enable register (TIER). To issue an A/D converter start request at a TCNT_4 underflow (trough), set the TTGE2 bit in TIER_4 to 1.

Interrupt Skipping in Complementary PWM Mode:

Interrupts TGIA_3 (at the crest) and TCIV_4 (at the trough) in channels 3 and 4 can be skipped up to seven times by making settings in the timer interrupt skipping set register (TITCR).

Transfers from a buffer register to a temporary register or a compare register can be skipped in coordination with interrupt skipping by making settings in the timer buffer transfer register (TBTER). For the linkage with buffer registers, refer to description 3, Buffer Transfer Control Linked with Interrupt Skipping, below.

A/D converter start requests generated by the A/D converter start request delaying function can also be skipped in coordination with interrupt skipping by making settings in the timer A/D converter request control register (TADCR). For the linkage with the A/D converter start request delaying function, refer to section 10.4.9, A/D Converter Start Request Delaying Function.

The setting of the timer interrupt skipping setting register (TITCR) must be done while the TGIA_3 and TCIV_4 interrupt requests are disabled by the settings of registers TIER_3 and TIER_4 along with under the conditions in which TGFA_3 and TCFV_4 flag settings by compare match never occur. Before changing the skipping count, be sure to clear the T3AEN and T4VEN bits to 0 to clear the skipping counter.

1. Example of Interrupt Skipping Operation Setting Procedure

Figure 10.73 shows an example of the interrupt skipping operation setting procedure. Figure 10.74 shows the periods during which interrupt skipping count can be changed.

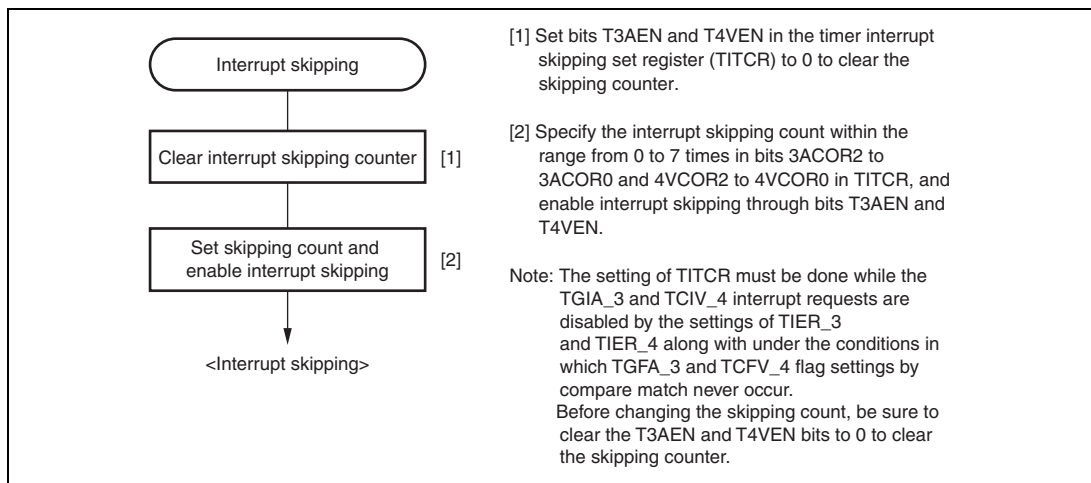

Figure 10.73 Example of Interrupt Skipping Operation Setting Procedure

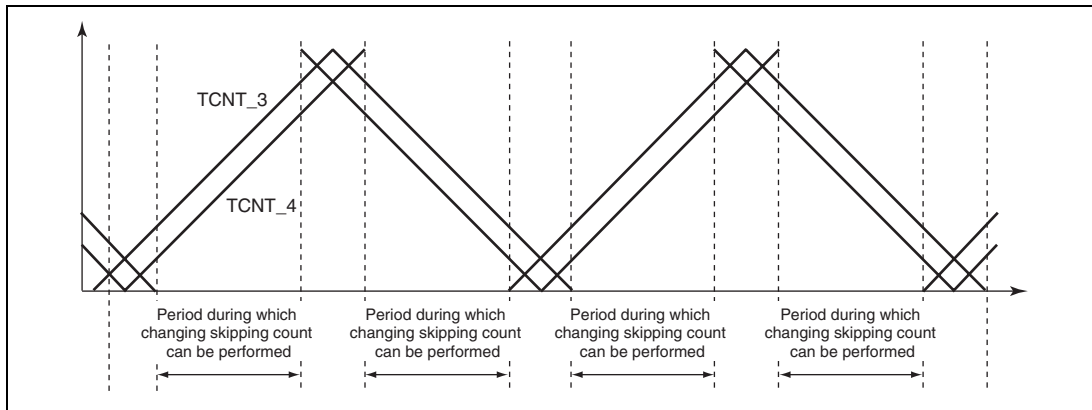

Figure 10.74 Periods during which Interrupt Skipping Count Can be Changed

2. Example of Interrupt Skipping Operation

Figure 10.75 shows an example of TGIA_3 interrupt skipping in which the interrupt skipping count is set to three by the 3ACOR bit and the T3AEN bit is set to 1 in the timer interrupt skipping set register (TITCR).

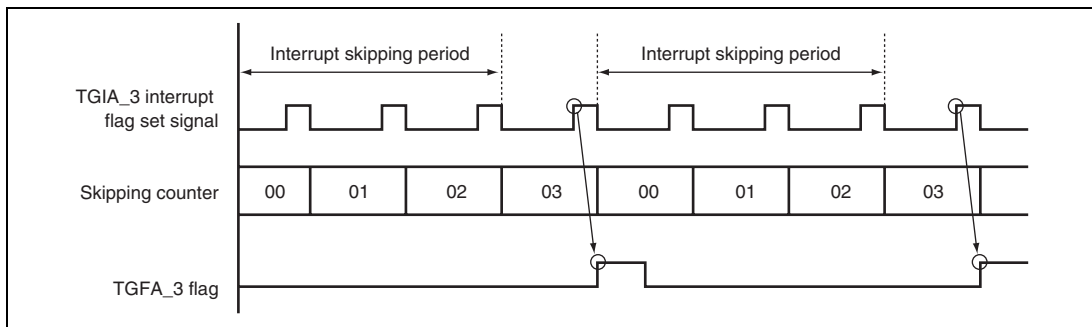

Figure 10.75 Example of Interrupt Skipping Operation

3. Buffer Transfer Control Linked with Interrupt Skipping

In complementary PWM mode, whether to transfer data from a buffer register to a temporary register and whether to link the transfer with interrupt skipping can be specified with the BTE1 and BTE0 bits in the timer buffer transfer set register (TBTER).

Figure 10.76 shows an example of operation when buffer transfer is suppressed (BTE1 = 0 and BTE0 = 1). While this setting is valid, data is not transferred from the buffer register to the temporary register.

Figure 10.77 shows an example of operation when buffer transfer is linked with interrupt skipping (BTE1 = 1 and BTE0 = 0). While this setting is valid, data is not transferred from the buffer register outside the buffer transfer-enabled period.

Note that the buffer transfer-enabled period depends on the T3AEN and T4VEN bit settings in the timer interrupt skipping set register (TITCR). Figure 10.78 shows the relationship between the T3AEN and T4VEN bit settings in TITCR and buffer transfer-enabled period.

Note: This function must always be used in combination with interrupt skipping.

When interrupt skipping is disabled (the T3AEN and T4VEN bits in the timer interrupt skipping set register (TITCR) are cleared to 0 or the skipping count set bits (3ACOR and 4VCOR) in TITCR are cleared to 0), make sure that buffer transfer is not linked with interrupt skipping (clear the BTE1 bit in the timer buffer transfer set register (TBTER) to 0). If buffer transfer is linked with interrupt skipping while interrupt skipping is disabled, buffer transfer is never performed.

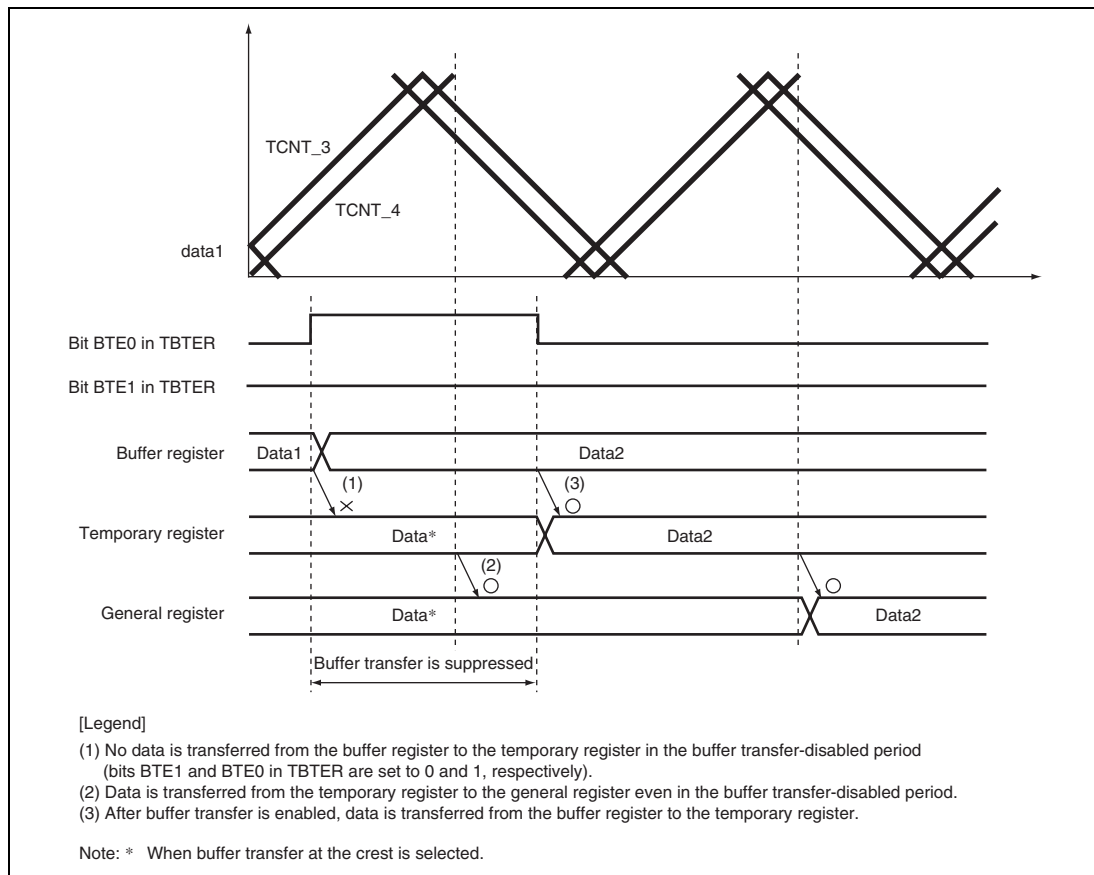

Figure 10.76 Example of Operation when Buffer Transfer Is Suppressed (BTE1 = 0 and BTE0 = 1)

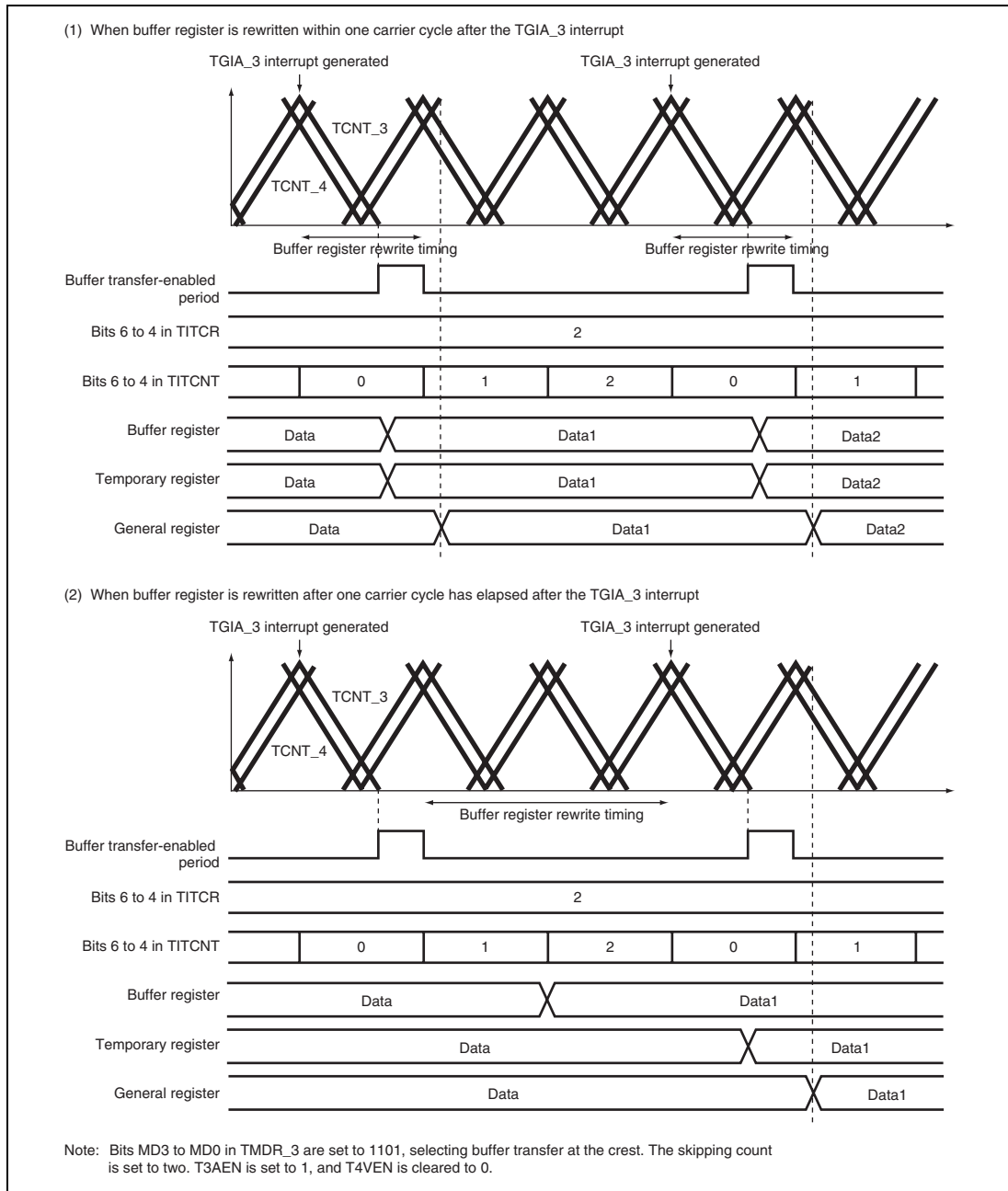

Figure 10.77 Example of Operation when Buffer Transfer Is Linked with Interrupt Skipping (BTE1 = 1 and BTE0 = 0)

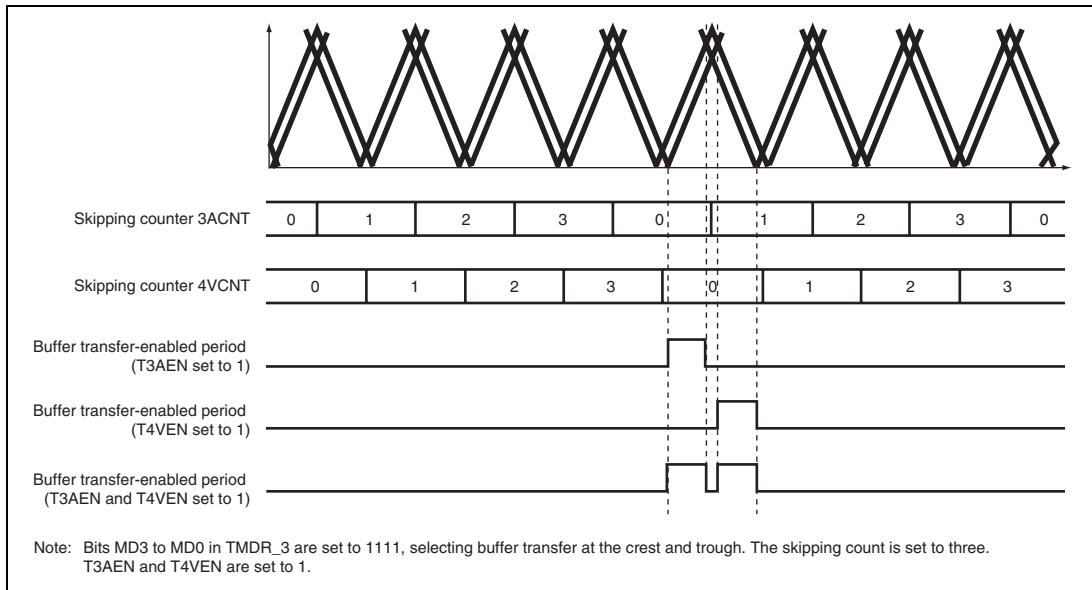

Figure 10.78 Relationship between Bits T3AEN and T4VEN in TITCR and Buffer Transfer-Enabled Period

Complementary PWM Mode Output Protection Function:

Complementary PWM mode output has the following protection functions.

1. Register and counter miswrite prevention function

With the exception of the buffer registers, which can be rewritten at any time, access by the CPU can be enabled or disabled for the mode registers, control registers, compare registers, and counters used in complementary PWM mode by means of the RWE bit in the timer read/write enable register (TRWER). The applicable registers are some (21 in total) of the registers in channels 3 and 4 shown in the following:

— TCR_3 and TCR_4, TMDR_3 and TMDR_4, TIORH_3 and TIORH_4, TIORL_3 and TIORL_4, TIER_3 and TIER_4, TCNT_3 and TCNT_4, TGRA_3 and TGRA_4, TGRB_3 and TGRB_4, TOER, TOCR, TGCR, TCDR, and TDDR.

This function enables miswriting due to CPU runaway to be prevented by disabling CPU access to the mode registers, control registers, and counters. When the applicable registers are read in the access-disabled state, undefined values are returned. Writing to these registers is ignored.

2. Halting of PWM output by external signal

The 6-phase PWM output pins can be set automatically to the high-impedance state by inputting specified external signals. There are four external signal input pins.

See section 12, Port Output Enable (POE), for details.

3. Halting of PWM output when oscillator is stopped

If it is detected that the clock input to this LSI has stopped, the 6-phase PWM output pins automatically go to the high-impedance state. The pin states are not guaranteed when the clock is restarted.

See section 4.7, Function for Detecting Oscillator Stop.

10.4.9 A/D Converter Start Request Delaying Function

A/D converter start requests can be issued in channel 4 by making settings in the timer A/D converter start request control register (TADCR), timer A/D converter start request cycle set registers (TADCORA_4 and TADCORB_4), and timer A/D converter start request cycle set buffer registers (TADCOBRA_4 and TADCOBRB_4).

The A/D converter start request delaying function compares TCNT_4 with TADCORA_4 or TADCORB_4, and when their values match, the function issues a respective A/D converter start request (TRG4AN or TRG4BN).

A/D converter start requests (TRG4AN and TRG4BN) can be skipped in coordination with interrupt skipping by making settings in the ITA3AE, ITA4VE, ITB3AE, and ITB4VE bits in TADCR.

1. Example of Procedure for Specifying A/D Converter Start Request Delaying Function

Figure 10.79 shows an example of procedure for specifying the A/D converter start request delaying function.

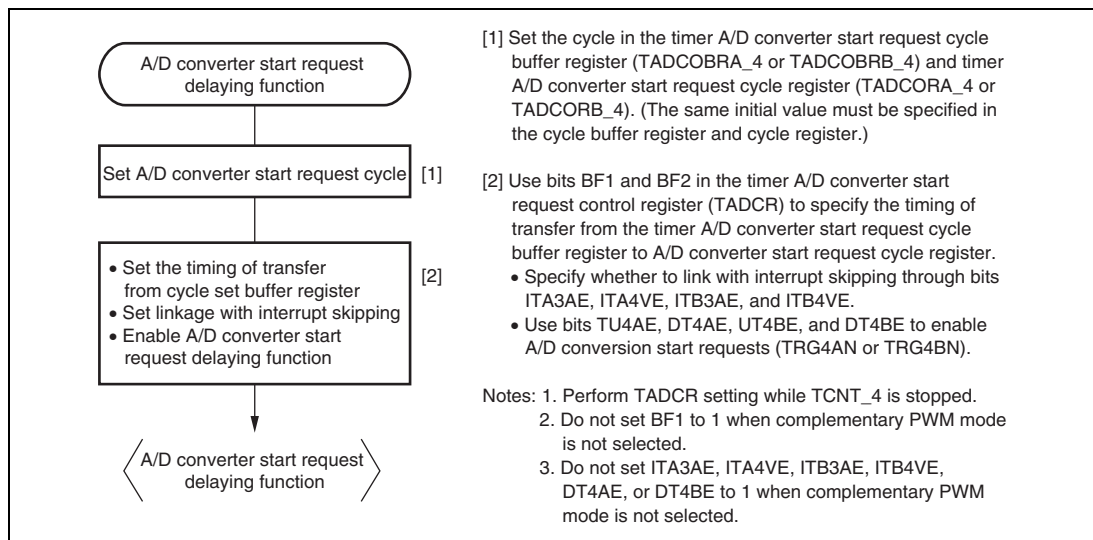

Figure 10.79 Example of Procedure for Specifying A/D Converter Start Request Delaying Function

2. Basic Operation Example of A/D Converter Start Request Delaying Function

Figure 10.80 shows a basic example of A/D converter request signal (TRG4AN) operation when the trough of TCNT_4 is specified for the buffer transfer timing and an A/D converter start request signal is output during TCNT_4 down-counting.

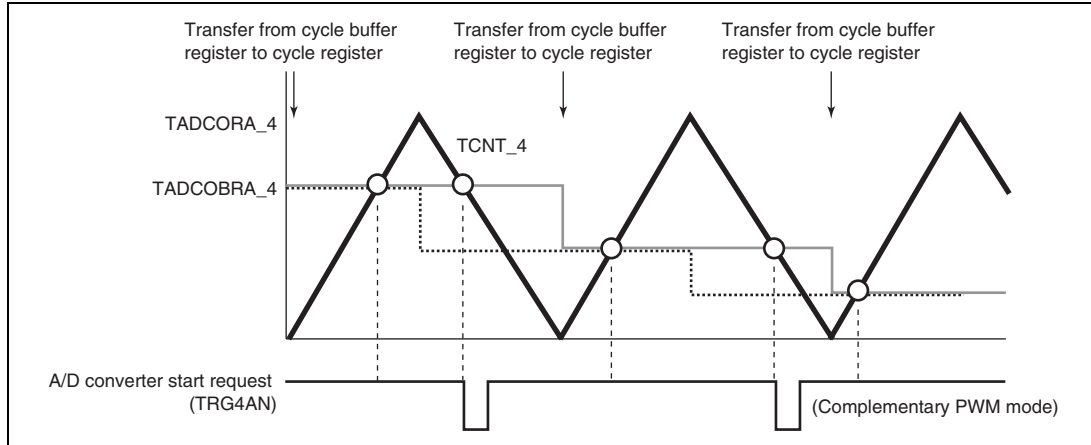

Figure 10.80 Basic Example of A/D Converter Start Request Signal (TRG4AN) Operation

3. Buffer Transfer

The data in the timer A/D converter start request cycle set registers (TADCORA_4 and TADCORB_4) is updated by writing data to the timer A/D converter start request cycle set buffer registers (TADCOBRA_4 and TADCOBRB_4). Data is transferred from the buffer registers to the respective cycle set registers at the timing selected with the BF1 and BF0 bits in the timer A/D converter start request control register (TADCR_4).

4. A/D Converter Start Request Delaying Function Linked with Interrupt Skipping

A/D converter start requests (TRG4AN and TRG4BN) can be issued in coordination with interrupt skipping by making settings in the ITA3AE, ITA4VE, ITB3AE, and ITB4VE bits in the timer A/D converter start request control register (TADCR).

Figure 10.81 shows an example of A/D converter start request signal (TRG4AN) operation when TRG4AN output is enabled during TCNT_4 up-counting and down-counting and A/D converter start requests are linked with interrupt skipping.

Figure 10.82 shows another example of A/D converter start request signal (TRG4AN) operation when TRG4AN output is enabled during TCNT_4 up-counting and A/D converter start requests are linked with interrupt skipping.

Note: This function must be used in combination with interrupt skipping.
 When interrupt skipping is disabled (the T3AEN and T4VEN bits in the timer interrupt skipping set register (TITCR) are cleared to 0 or the skipping count set bits (3ACOR and 4VCOR) in TITCR are cleared to 0), make sure that A/D converter start requests are not linked with interrupt skipping (clear the ITA3AE, ITA4VE, ITB3AE, and ITB4VE bits in the timer A/D converter start request control register (TADCR) to 0).

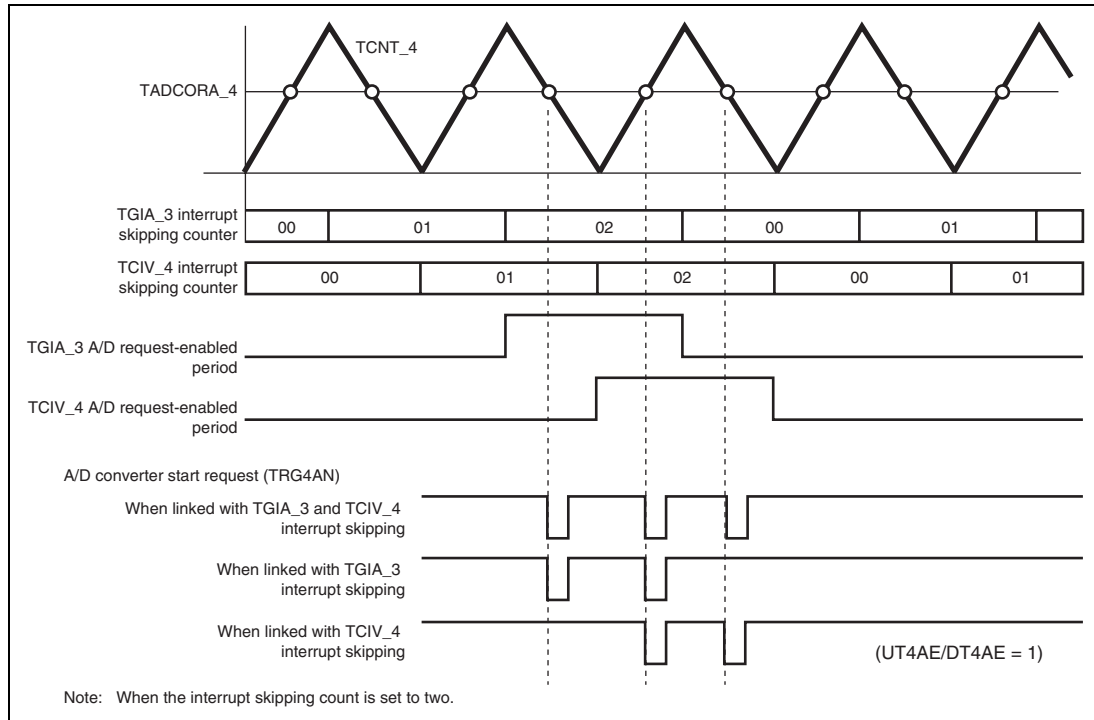

Figure 10.81 Example of A/D Converter Start Request Signal (TRG4AN) Operation Linked with Interrupt Skipping

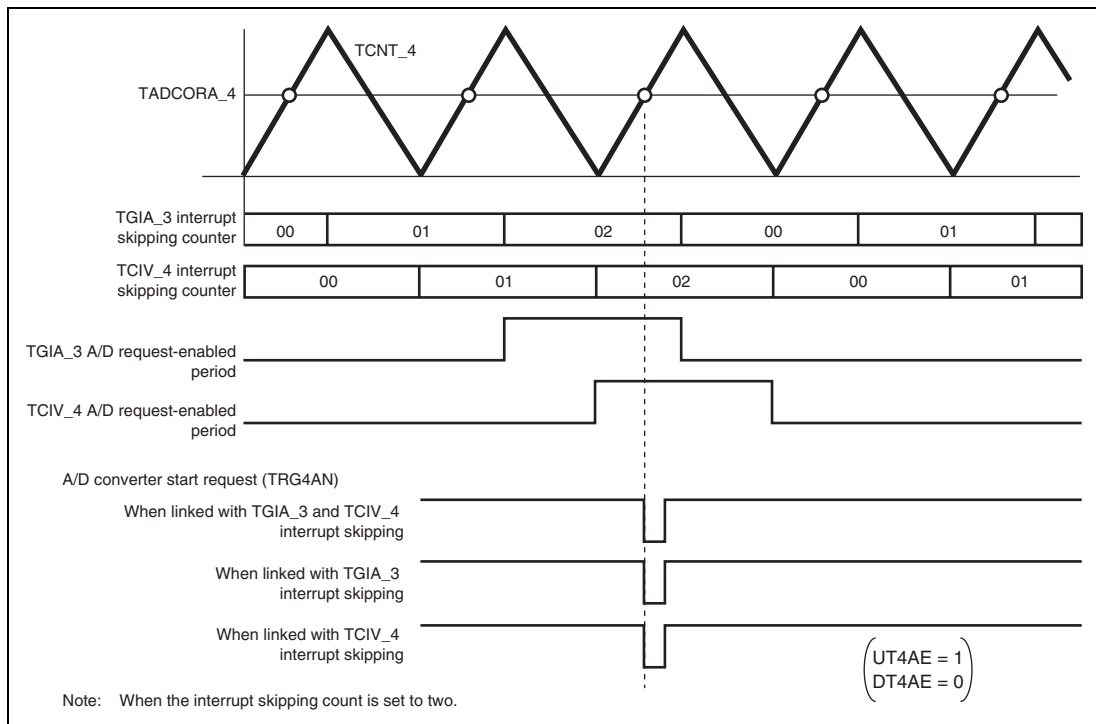

Figure 10.82 Example of A/D Converter Start Request Signal (TRG4AN) Operation Linked with Interrupt Skipping

10.4.10 MTU2–MTU2S Synchronous Operation

MTU2–MTU2S Synchronous Counter Start: The counters in the MTU2 and MTU2S which operate at different clock systems can be started synchronously by making the TCSYSTR settings in the MTU2.

1. Example of MTU2–MTU2S Synchronous Counter Start Setting Procedure

Figure 10.83 shows an example of synchronous counter start setting procedure.

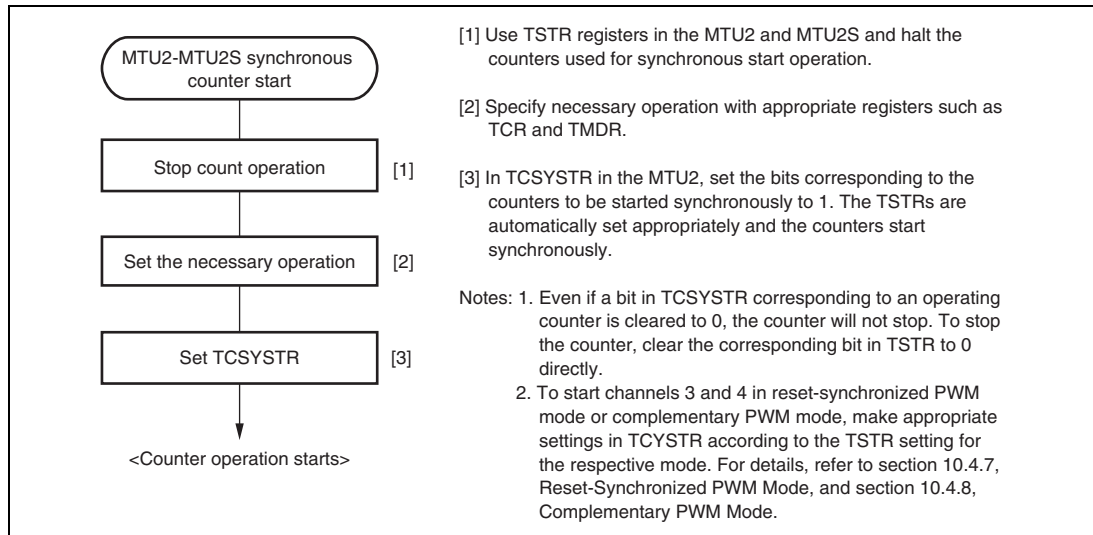

Figure 10.83 Example of Synchronous Counter Start Setting Procedure

2. Examples of Synchronous Counter Start Operation

Figures 10.84 (1), 10.84 (2), 10.84 (3), and 10.84 (4) show examples of synchronous counter start operation when the clock frequency ratio between the MTU2 and MTU2S is 1:1, 1:2, 1:3, and 1:4, respectively.

In these examples, the counter clock of the MTU2 is $MP\phi/1$.

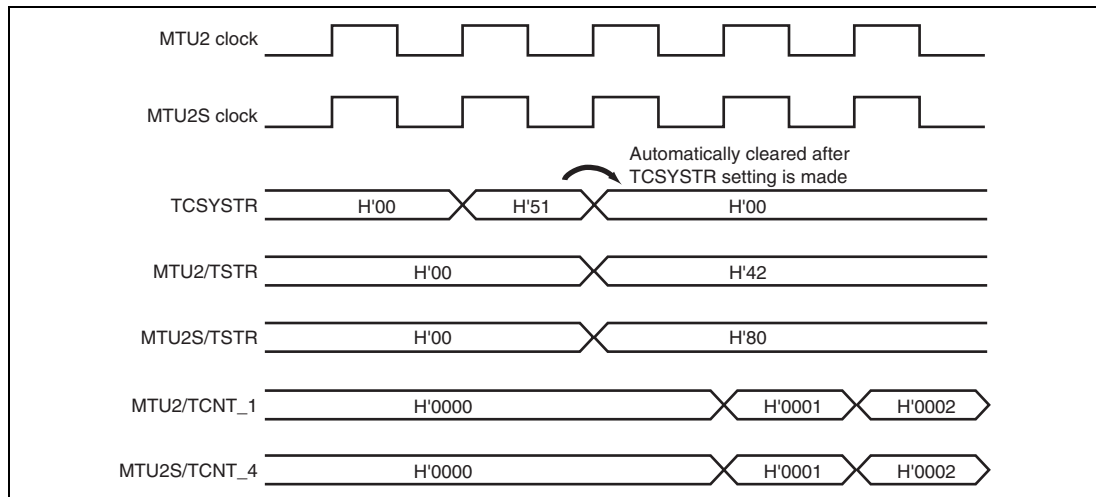

Figure 10.84 (1) Example of Synchronous Counter Start Operation (MTU2-to-MTU2S Clock Frequency Ratio = 1:1)

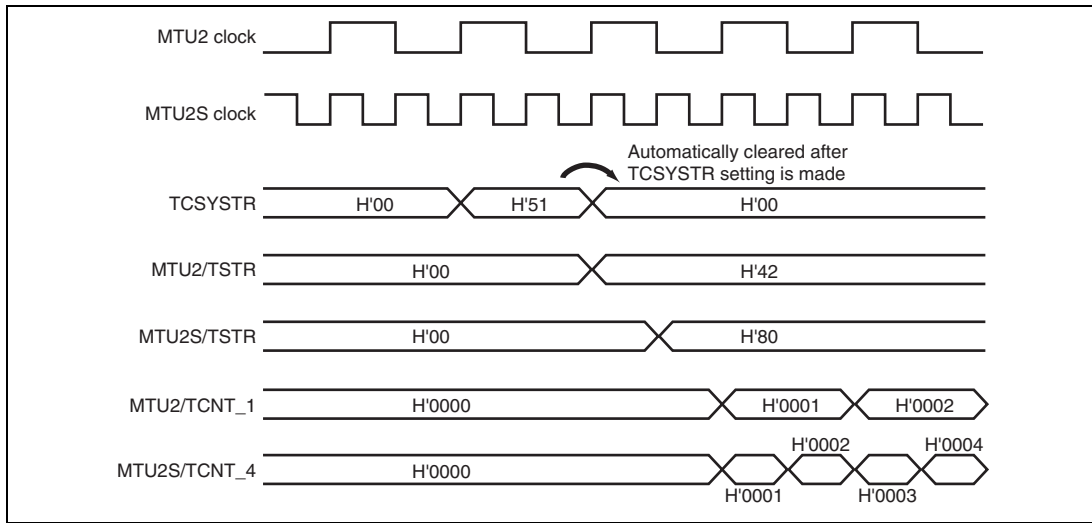

Figure 10.84 (2) Example of Synchronous Counter Start Operation (MTU2-to-MTU2S Clock Frequency Ratio = 1:2)

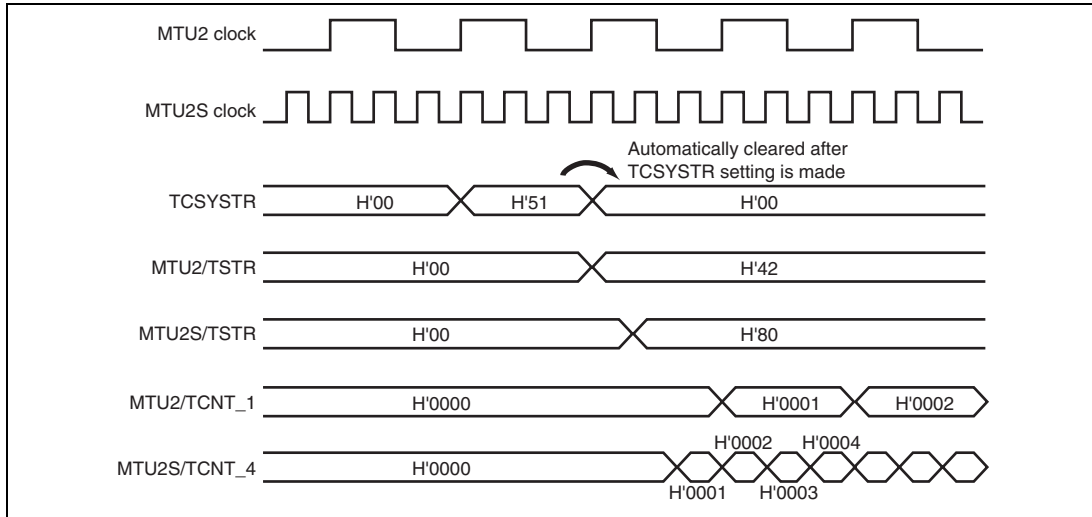

Figure 10.84 (3) Example of Synchronous Counter Start Operation (MTU2-to-MTU2S Clock Frequency Ratio = 1:3)

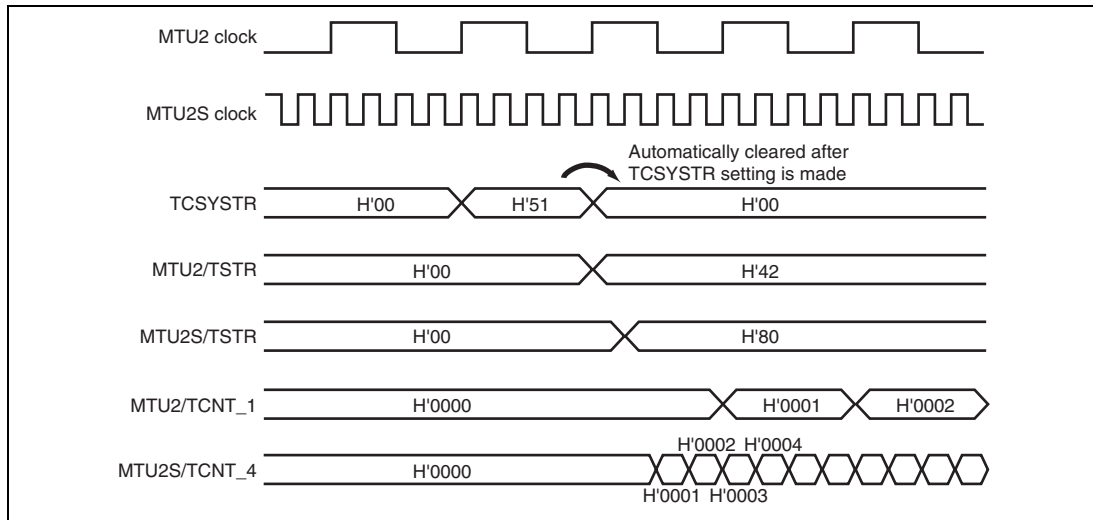

Figure 10.84 (4) Example of Synchronous Counter Start Operation (MTU2-to-MTU2S Clock Frequency Ratio = 1:4)

MTU2S Counter Clearing Caused by MTU2 Flag Setting Source (MTU2–MTU2S

Synchronous Counter Clearing): The MTU2S counters can be cleared by sources for setting the flags in TSR_0 to TSR_2 in the MTU2 through the TSYCR_3 settings in the MTU2S.

1. Example of Procedure for Specifying MTU2S Counter Clearing by MTU2 Flag Setting Source

Figure 10.85 shows an example of procedure for specifying MTU2S counter clearing by MTU2 flag setting source.

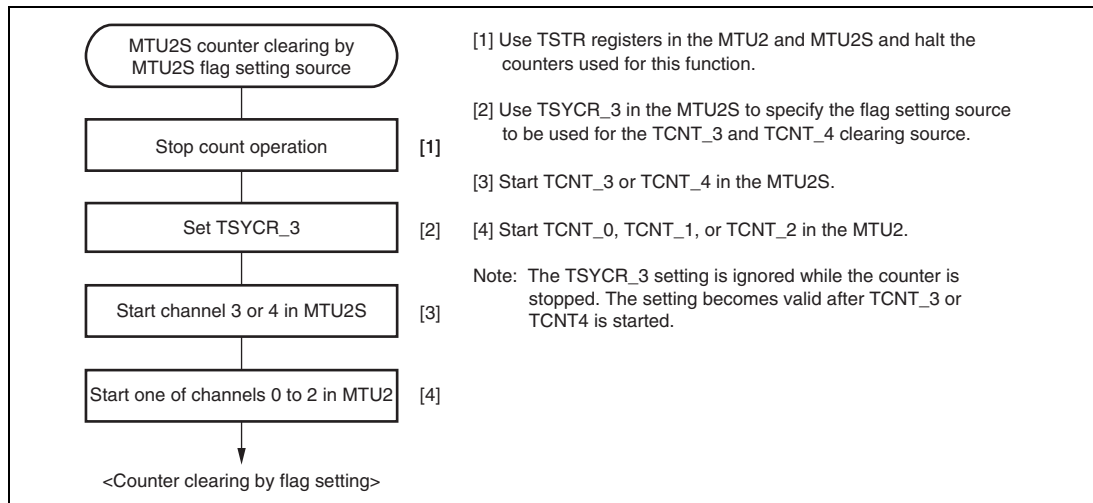

Figure 10.85 Example of Procedure for Specifying MTU2S Counter Clearing by MTU2 Flag Setting Source

2. Examples of MTU2S Counter Clearing Caused by MTU2 Flag Setting Source

Figures 10.86 (1) and 10.86 (2) show examples of MTS2S counter clearing caused by MTU2 flag setting source.

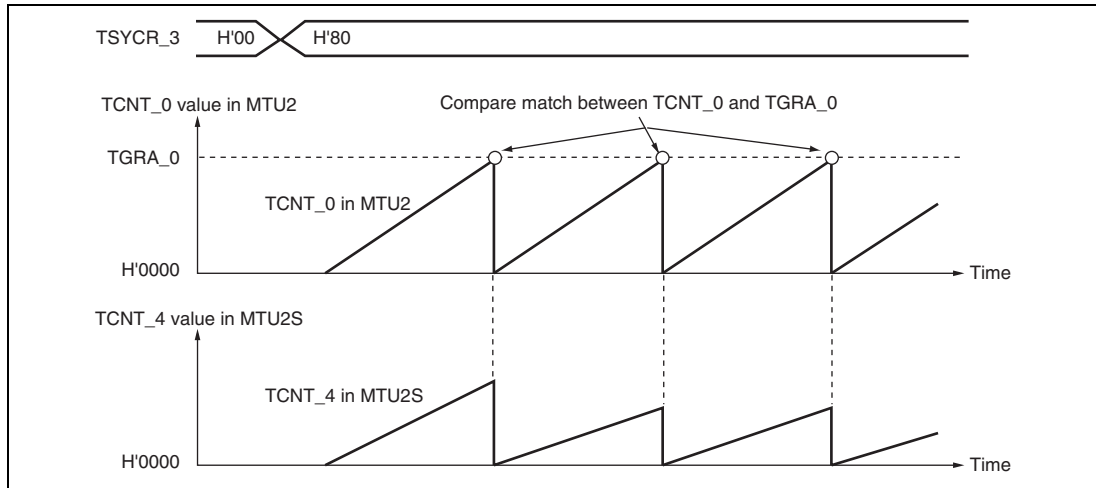

Figure 10.86 (1) Example of MTU2S Counter Clearing Caused by MTU2 Flag Setting Source (1)

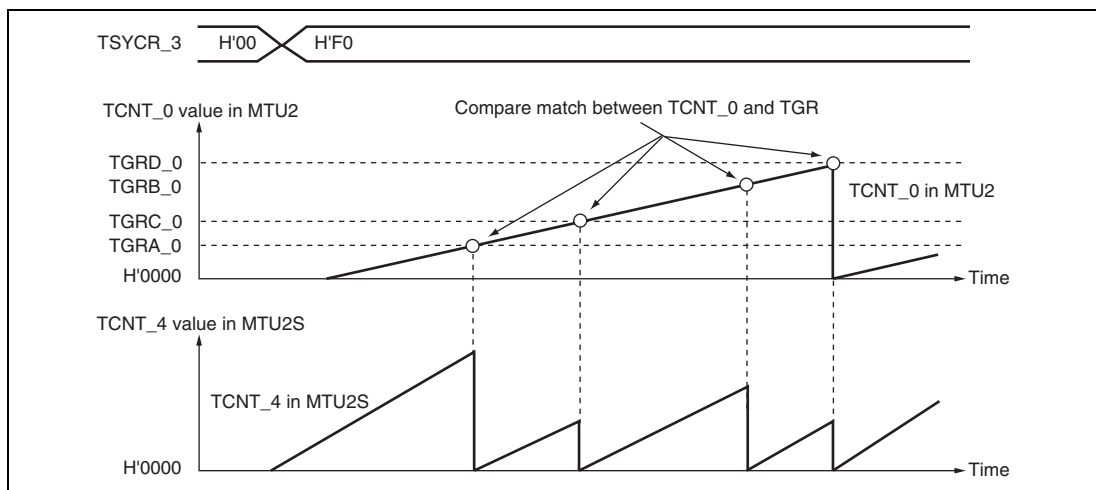

Figure 10.86 (2) Example of MTU2S Counter Clearing Caused by MTU2 Flag Setting Source (2)

10.4.11 External Pulse Width Measurement

The pulse widths of up to three external input lines can be measured in channel 5.

Example of External Pulse Width Measurement Setting Procedure:

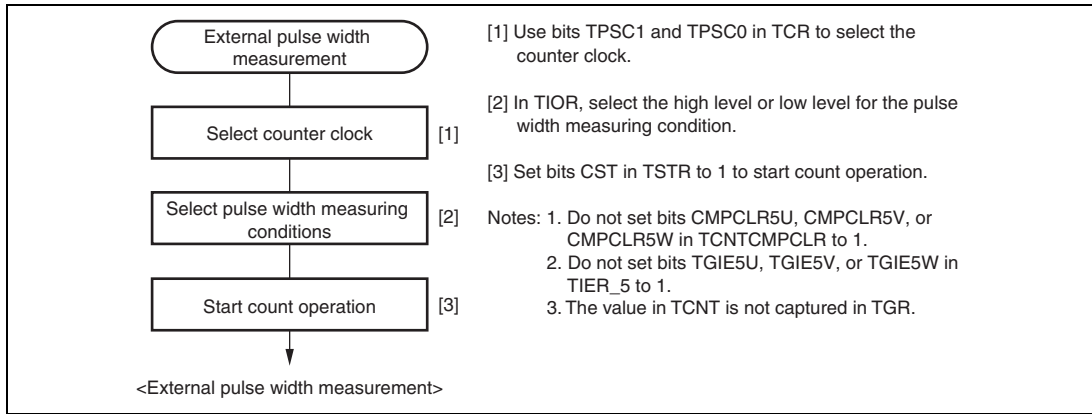

Figure 10.87 Example of External Pulse Width Measurement Setting Procedure

Example of External Pulse Width Measurement:

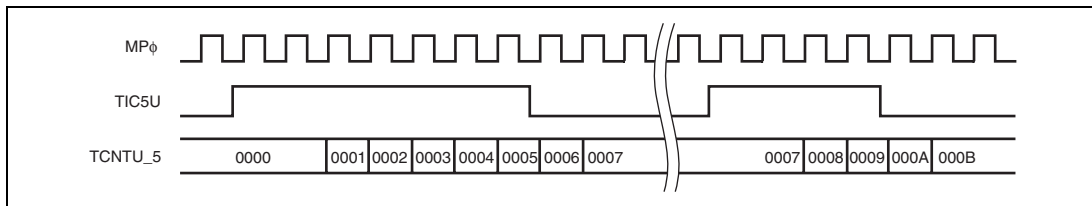

Figure 10.88 Example of External Pulse Width Measurement (Measuring High Pulse Width)

10.4.12 Dead Time Compensation

By measuring the delay of the output waveform and reflecting it to duty, the external pulse width measurement function can be used as the dead time compensation function while the complementary PWM is in operation.

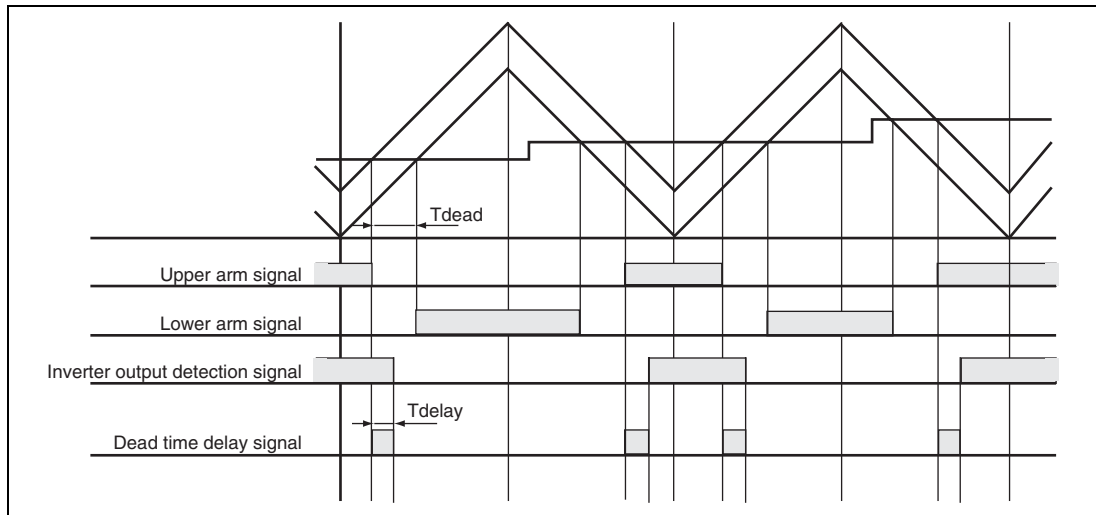

Figure 10.89 Delay in Dead Time in Complementary PWM Operation

Example of Dead Time Compensation Setting Procedure: Figure 10.90 shows an example of dead time compensation setting procedure by using three counters in channel 5.

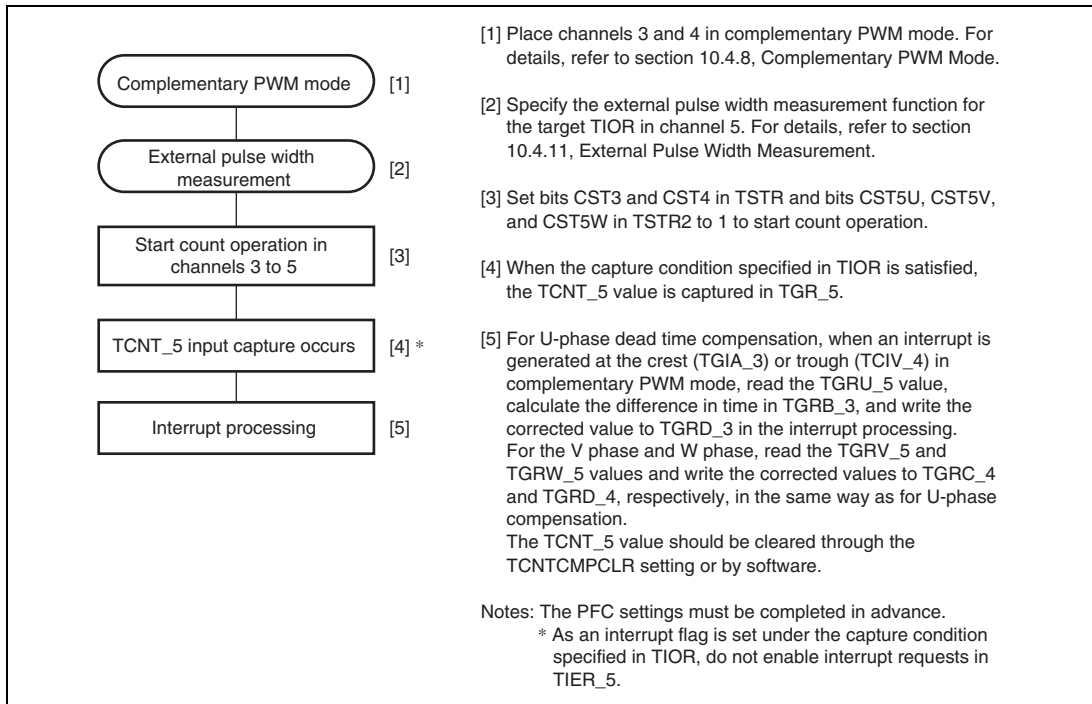

Figure 10.90 Example of Dead Time Compensation Setting Procedure

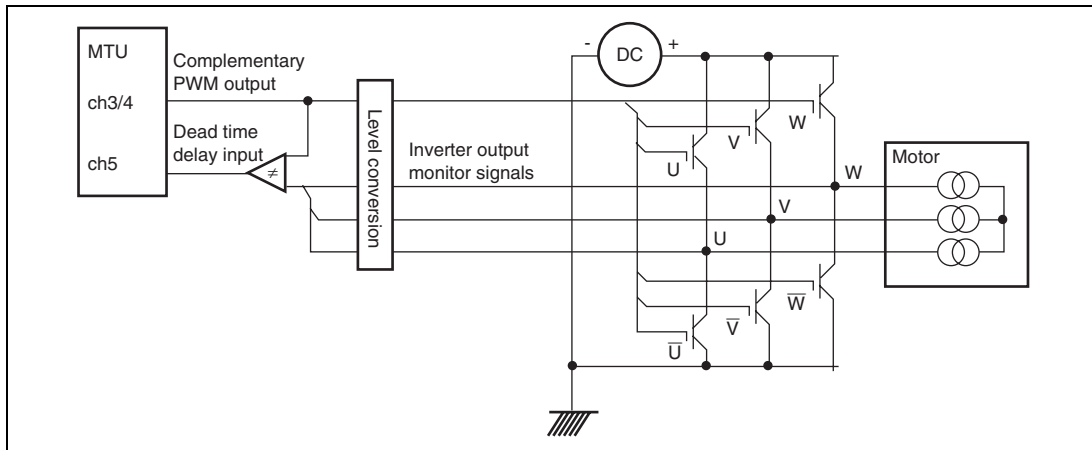

Figure 10.91 Example of Motor Control Circuit Configuration

10.4.13 TCNT Capture at Crest and/or Trough in Complementary PWM Operation

The TCNT value is captured in TGR at either the crest or trough or at both the crest and trough during complementary PWM operation. The timing for capturing in TGR can be selected by TIOR.

Figure 10.92 is an operating example in which TCNT is used as a free-running counter without being cleared, and the TCNT value is captured in TGR at the specified timing (either crest or trough, or both crest and trough).

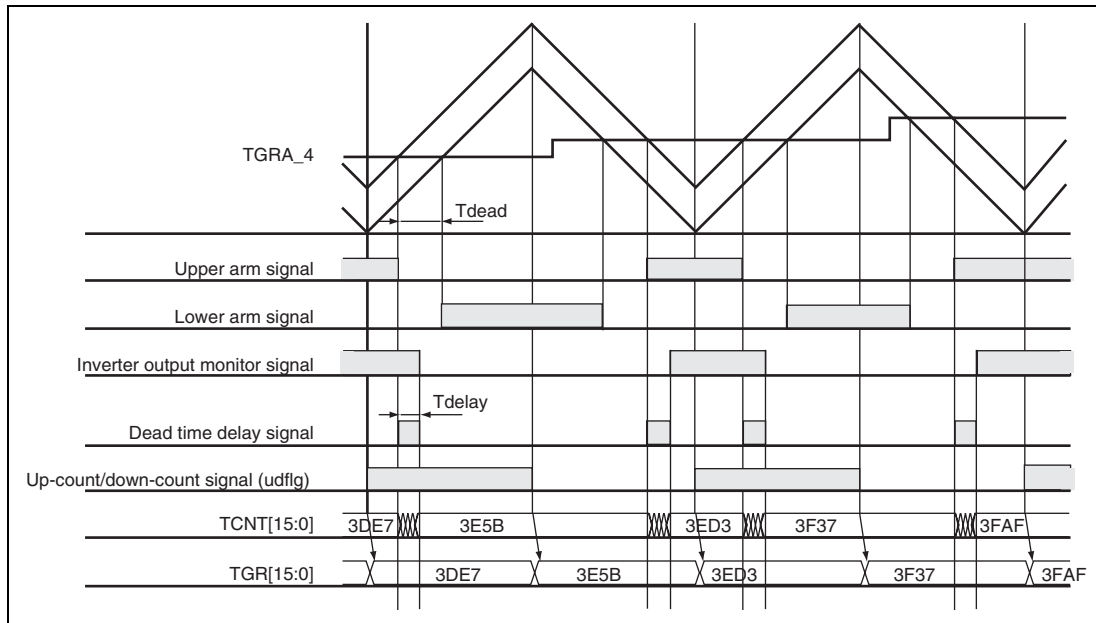

Figure 10.92 TCNT Capturing at Crest and/or Trough in Complementary PWM Operation

10.5 Interrupt Sources

10.5.1 Interrupt Sources and Priorities

There are three kinds of MTU2 interrupt source; TGR input capture/compare match, TCNT overflow, and TCNT underflow. Each interrupt source has its own status flag and enable/disabled bit, allowing the generation of interrupt request signals to be enabled or disabled individually.

When an interrupt request is generated, the corresponding status flag in TSR is set to 1. If the corresponding enable/disable bit in TIER is set to 1 at this time, an interrupt is requested. The interrupt request is cleared by clearing the status flag to 0.

Relative channel priorities can be changed by the interrupt controller, however the priority order within a channel is fixed. For details, see section 6, Interrupt Controller (INTC).

Table 10.57 lists the MTU2 interrupt sources.

Table 10.57 MTU2 Interrupts

Channel	Name	Interrupt Source	Interrupt Flag	DTC Activation	Priority		
0	TGIA_0	TGRA_0 input capture/compare match	TGFA_0	Possible	High ↑		
	TGIB_0	TGRB_0 input capture/compare match	TGFB_0	Possible			
	TGIC_0	TGRC_0 input capture/compare match	TGFC_0	Possible			
	TGID_0	TGRD_0 input capture/compare match	TGFD_0	Possible			
	TCIV_0	TCNT_0 overflow	TCFV_0	Not possible			
	TGIE_0	TGRE_0 compare match	TGFE_0	Not possible			
	TGIF_0	TGRF_0 compare match	TGFF_0	Not possible			
1	TGIA_1	TGRA_1 input capture/compare match	TGFA_1	Possible	↑		
	TGIB_1	TGRB_1 input capture/compare match	TGFB_1	Possible			
	TCIV_1	TCNT_1 overflow	TCFV_1	Not possible			
	TCIU_1	TCNT_1 underflow	TCFU_1	Not possible			
2	TGIA_2	TGRA_2 input capture/compare match	TGFA_2	Possible		↑	
	TGIB_2	TGRB_2 input capture/compare match	TGFB_2	Possible			
	TCIV_2	TCNT_2 overflow	TCFV_2	Not possible			
	TCIU_2	TCNT_2 underflow	TCFU_2	Not possible			
3	TGIA_3	TGRA_3 input capture/compare match	TGFA_3	Possible			↑
	TGIB_3	TGRB_3 input capture/compare match	TGFB_3	Possible			
	TGIC_3	TGRC_3 input capture/compare match	TGFC_3	Possible			
	TGID_3	TGRD_3 input capture/compare match	TGFD_3	Possible			
	TCIV_3	TCNT_3 overflow	TCFV_3	Not possible			
4	TGIA_4	TGRA_4 input capture/compare match	TGFA_4	Possible	↑		
	TGIB_4	TGRB_4 input capture/compare match	TGFB_4	Possible			
	TGIC_4	TGRC_4 input capture/compare match	TGFC_4	Possible			
	TGID_4	TGRD_4 input capture/compare match	TGFD_4	Possible			
	TCIV_4	TCNT_4 overflow/underflow	TCFV_4	Possible			
5	TGIU_5	TGRU_5 input capture/compare match	TGFU_5	Possible		↓	
	TGIV_5	TGRV_5 input capture/compare match	TGFV_5	Possible			
	TGIW_5	TGRW_5 input capture/compare match	TGFW_5	Possible			Low

Note: This table shows the initial state immediately after a reset. The relative channel priorities can be changed by the interrupt controller.

Input Capture/Compare Match Interrupt: An interrupt is requested if the TGIE bit in TIER is set to 1 when the TGF flag in TSR is set to 1 by the occurrence of a TGR input capture/compare match on a particular channel. The interrupt request is cleared by clearing the TGF flag to 0. The MTU2 has 21 input capture/compare match interrupts, six for channel 0, four each for channels 3 and 4, two each for channels 1 and 2, and three for channel 5. The TGFE_0 and TGFF_0 flags in channel 0 are not set by the occurrence of an input capture.

Overflow Interrupt: An interrupt is requested if the TCIEV bit in TIER is set to 1 when the TCFV flag in TSR is set to 1 by the occurrence of TCNT overflow on a channel. The interrupt request is cleared by clearing the TCFV flag to 0. The MTU2 has five overflow interrupts, one for each channel.

Underflow Interrupt: An interrupt is requested if the TCIEU bit in TIER is set to 1 when the TCFU flag in TSR is set to 1 by the occurrence of TCNT underflow on a channel. The interrupt request is cleared by clearing the TCFU flag to 0. The MTU2 has two underflow interrupts, one each for channels 1 and 2.

10.5.2 DTC Activation

DTC Activation: The DTC can be activated by the TGR input capture/compare match interrupt in each channel or the overflow interrupt in channel 4. For details, see section 8, Data Transfer Controller (DTC).

A total of 20 MTU2 input capture/compare match interrupts and overflow interrupts can be used as DTC activation sources, four each for channels 0 and 3, two each for channels 1 and 2, five for channel 4, and three for channel 5.

10.5.3 A/D Converter Activation

The A/D converter can be activated by one of the following three methods in the MTU2. Table 10.58 shows the relationship between interrupt sources and A/D converter start request signals.

A/D Converter Activation by TGRA Input Capture/Compare Match or at TCNT_4 Trough in Complementary PWM Mode: The A/D converter can be activated by the occurrence of a TGRA input capture/compare match in each channel. In addition, if complementary PWM operation is performed while the TTGE2 bit in TIER_4 is set to 1, the A/D converter can be activated at the trough of TCNT_4 count (TCNT_4 = H'0000).

A/D converter start request signal TRGAN is issued to the A/D converter under either one of the following conditions.

- When the TGFA flag in TSR is set to 1 by the occurrence of a TGRA input capture/compare match on a particular channel while the TTGE bit in TIER is set to 1
- When the TCNT_4 count reaches the trough (TCNT_4 = H'0000) during complementary PWM operation while the TTGE2 bit in TIER_4 is set to 1

When either condition is satisfied, if A/D converter start signal TRGAN from the MTU2 is selected as the trigger in the A/D converter, A/D conversion will start.

A/D Converter Activation by Compare Match between TCNT_0 and TGRE_0: The A/D converter can be activated by generating A/D converter start request signal TRG0N when a compare match occurs between TCNT_0 and TGRE_0 in channel 0.

When the TGFE flag in TSR2_0 is set to 1 by the occurrence of a compare match between TCNT_0 and TGRE_0 in channel 0 while the TTGE2 bit in TIER2_0 is set to 1, A/D converter start request TGR0N is issued to the A/D converter. If A/D converter start signal TGR0N from the MTU2 is selected as the trigger in the A/D converter, A/D conversion will start.

A/D Converter Activation by A/D Converter Start Request Delaying Function: The A/D converter can be activated by generating A/D converter start request signal TRG4AN or TRG4BN when the TCNT_4 count matches the TADCORA or TADCORB value if the TAD4AE or TAD4BE bit in the A/D converter start request control register (TADCR) is set to 1. For details, refer to section 10.4.9, A/D Converter Start Request Delaying Function.

A/D conversion will start if A/D converter start signal TRG4AN from the MTU2 is selected as the trigger in the A/D converter when TRG4AN is generated or if TRG4BN from the MTU2 is selected as the trigger in the A/D converter when TRG4BN is generated.

Table 10.58 Interrupt Sources and A/D Converter Start Request Signals

Target Registers	Interrupt Source	A/D Converter Start Request Signal
TGRA_0 and TCNT_0	Input capture/compare match	TRGAN
TGRA_1 and TCNT_1		
TGRA_2 and TCNT_2		
TGRA_3 and TCNT_3		
TGRA_4 and TCNT_4		
TCNT_4	TCNT_4 Trough in complementary PWM mode	
TGRE_0 and TCNT_0	Compare match	TRG0N
TADCORA and TCNT_4		TRG4AN
TADCORB and TCNT_4		TRG4BN

10.6 Operation Timing

10.6.1 Input/Output Timing

TCNT Count Timing: Figures 10.93 and 10.94 show TCNT count timing in internal clock operation, and figure 10.95 shows TCNT count timing in external clock operation (normal mode), and figure 10.96 shows TCNT count timing in external clock operation (phase counting mode).

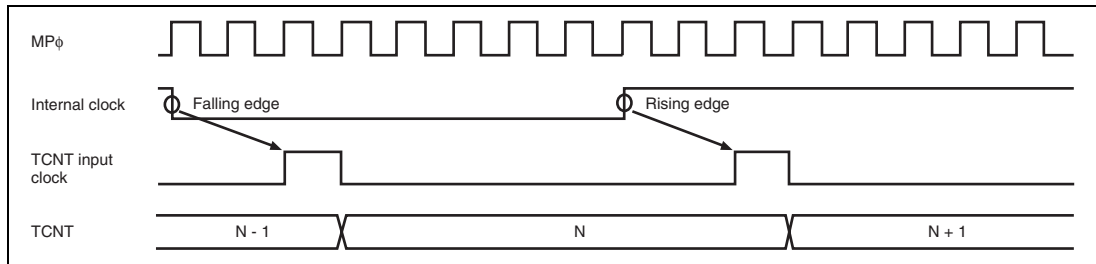

Figure 10.93 Count Timing in Internal Clock Operation (Channels 0 to 4)

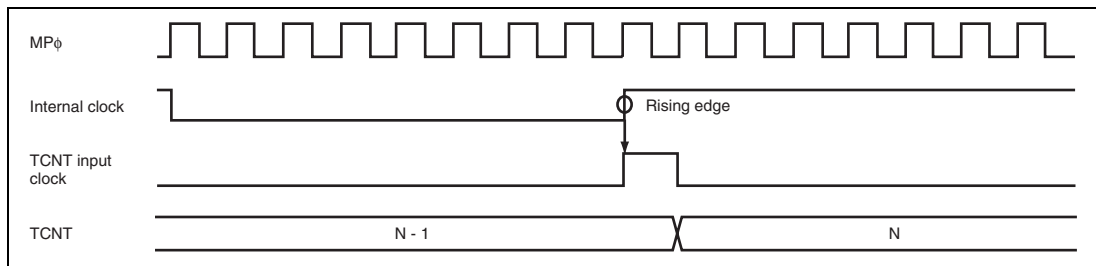

Figure 10.94 Count Timing in Internal Clock Operation (Channel 5)

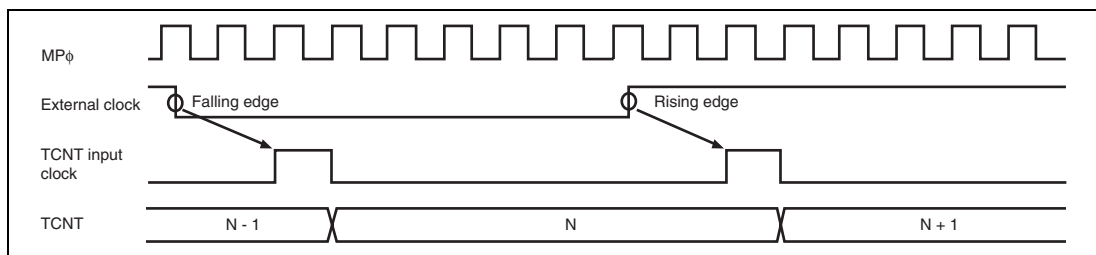

Figure 10.95 Count Timing in External Clock Operation (Channels 0 to 4)

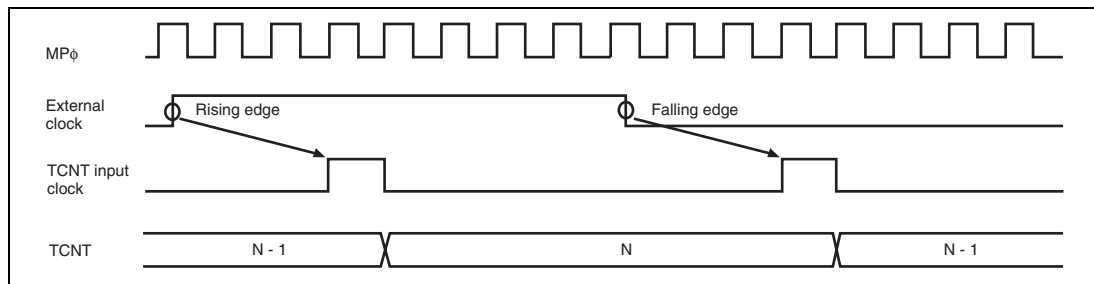

Figure 10.96 Count Timing in External Clock Operation (Phase Counting Mode)

Output Compare Output Timing: A compare match signal is generated in the final state in which TCNT and TGR match (the point at which the count value matched by TCNT is updated). When a compare match signal is generated, the output value set in TIOR is output at the output compare output pin (TIOC pin). After a match between TCNT and TGR, the compare match signal is not generated until the TCNT input clock is generated.

Figure 10.97 shows output compare output timing (normal mode and PWM mode) and figure 10.98 shows output compare output timing (complementary PWM mode and reset synchronous PWM mode).

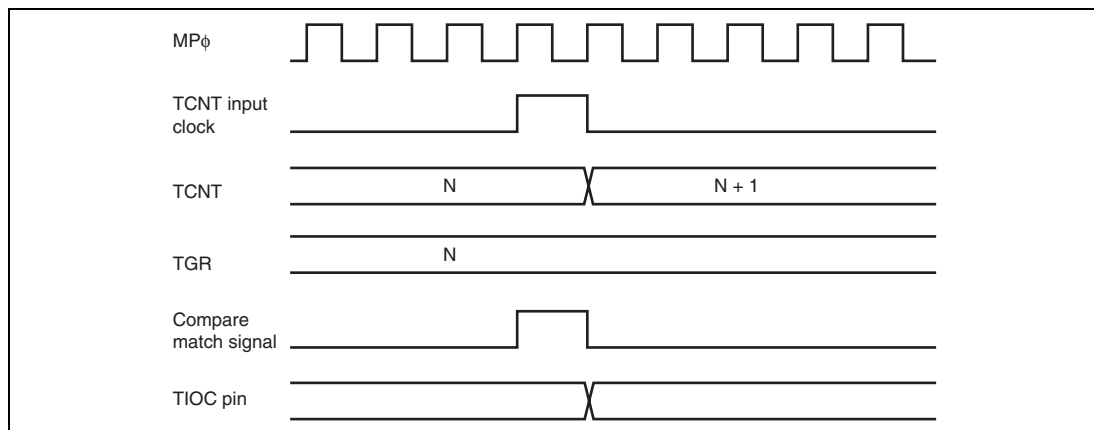

Figure 10.97 Output Compare Output Timing (Normal Mode/PWM Mode)

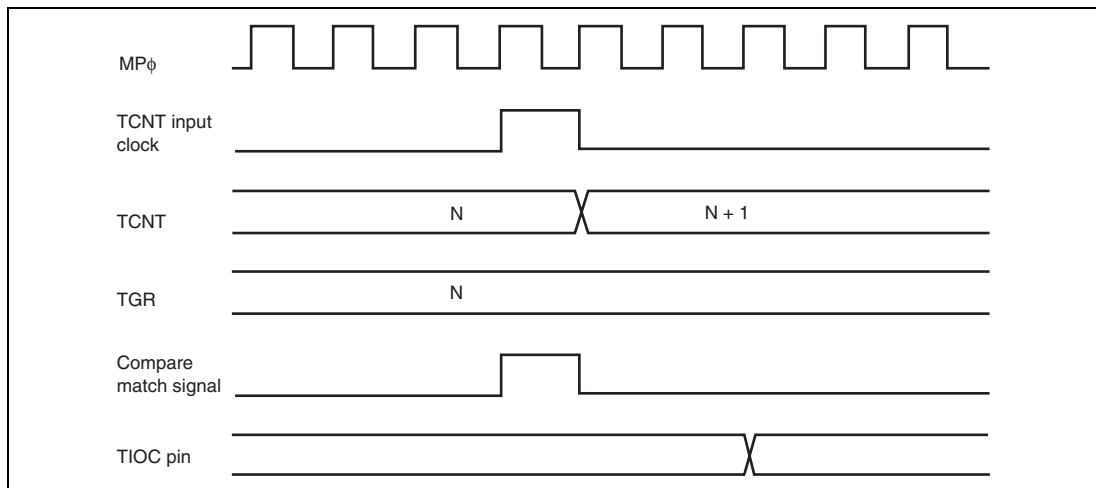

Figure 10.98 Output Compare Output Timing
(Complementary PWM Mode/Reset Synchronous PWM Mode)

Input Capture Signal Timing: Figure 10.99 shows input capture signal timing.

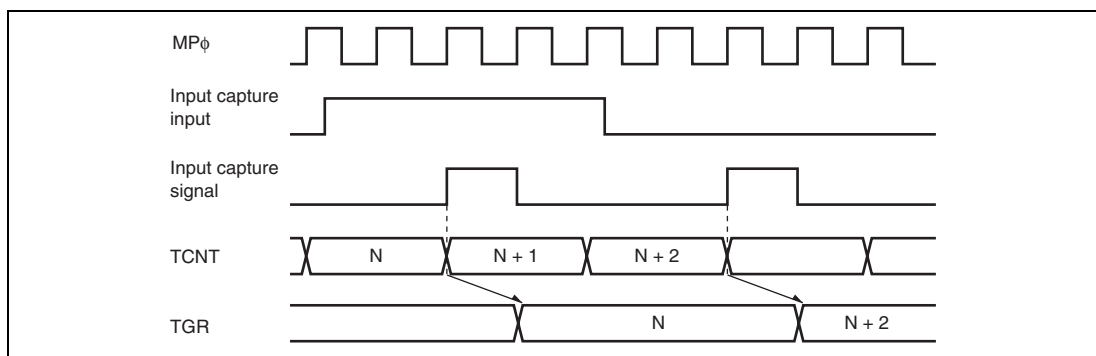

Figure 10.99 Input Capture Input Signal Timing

Timing for Counter Clearing by Compare Match/Input Capture: Figures 10.100 and 10.101 show the timing when counter clearing on compare match is specified, and figure 10.102 shows the timing when counter clearing on input capture is specified.

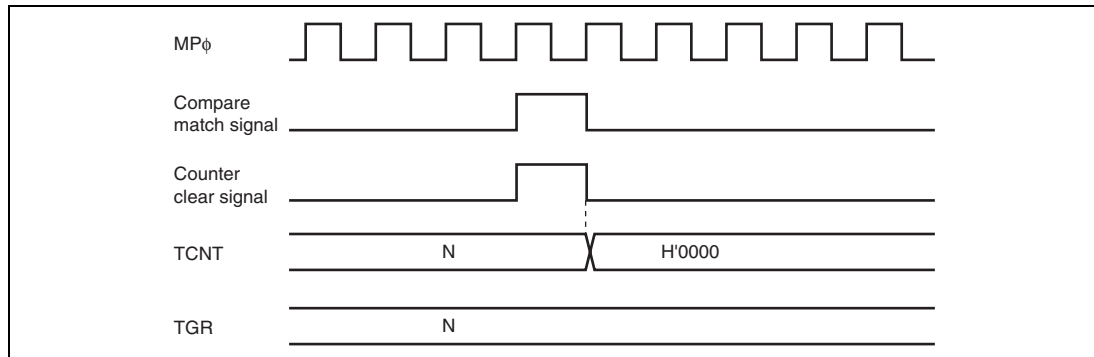

Figure 10.100 Counter Clear Timing (Compare Match) (Channels 0 to 4)

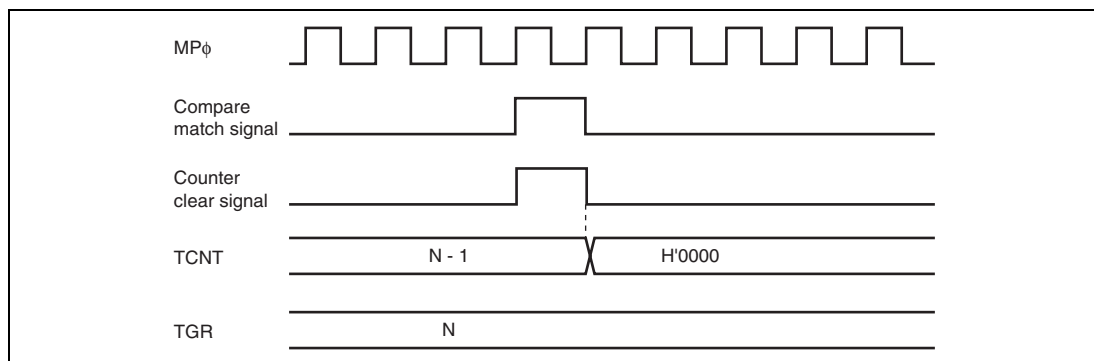

Figure 10.101 Counter Clear Timing (Compare Match) (Channel 5)

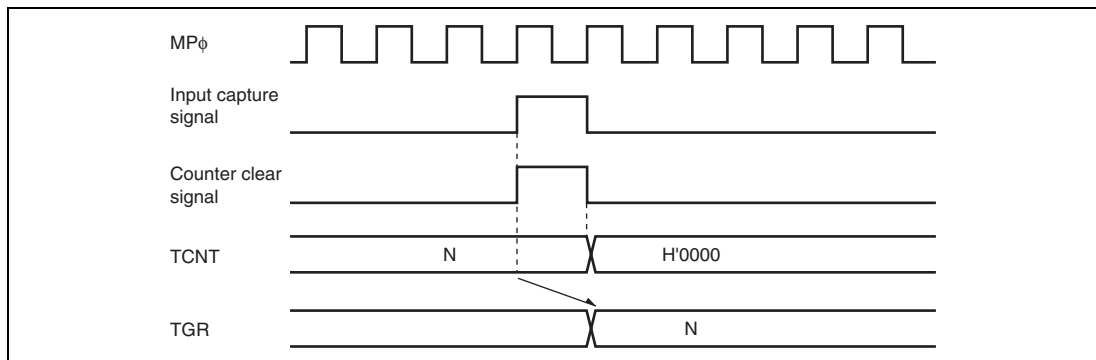

Figure 10.102 Counter Clear Timing (Input Capture) (Channels 0 to 5)

Buffer Operation Timing: Figures 10.103 to 10.105 show the timing in buffer operation.

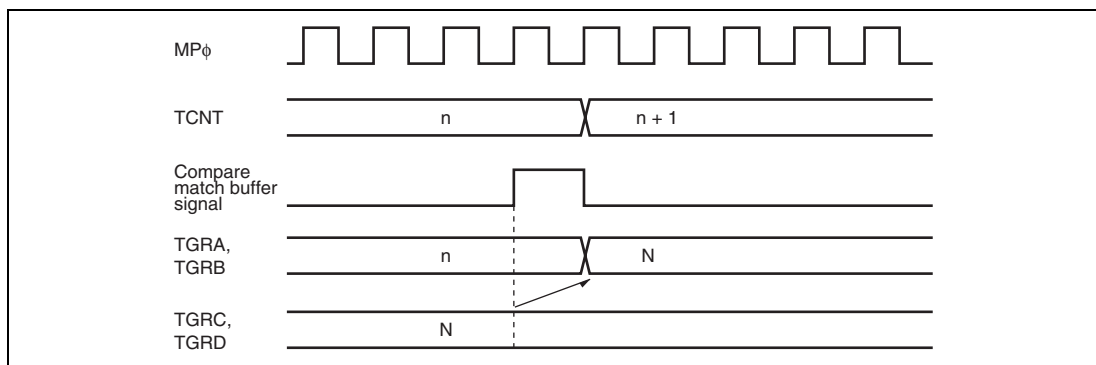

Figure 10.103 Buffer Operation Timing (Compare Match)

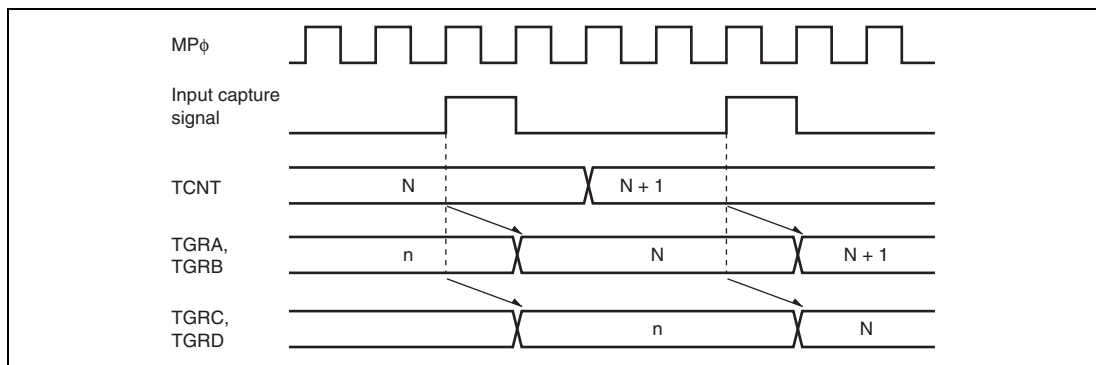

Figure 10.104 Buffer Operation Timing (Input Capture)

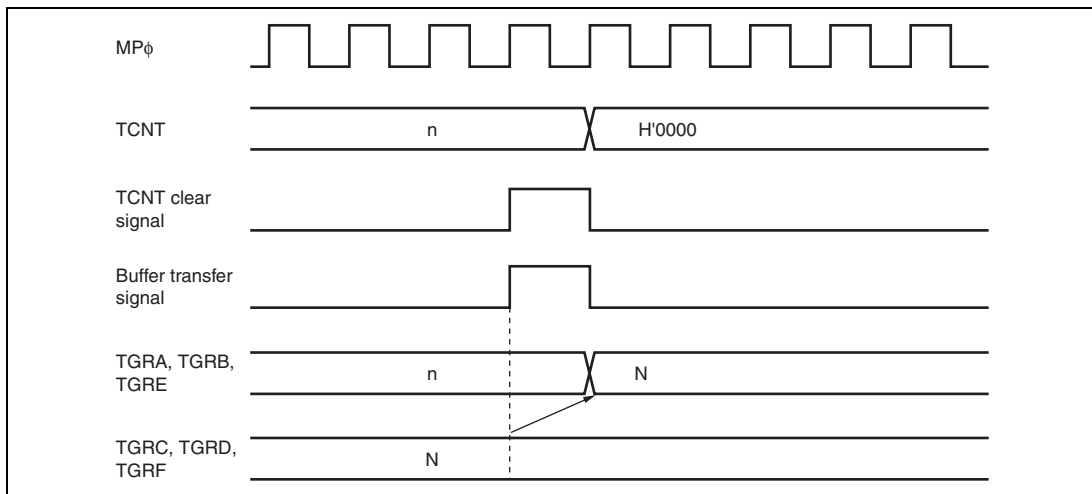

Figure 10.105 Buffer Transfer Timing (when TCNT Cleared)

Buffer Transfer Timing (Complementary PWM Mode): Figures 10.106 to 10.108 show the buffer transfer timing in complementary PWM mode.

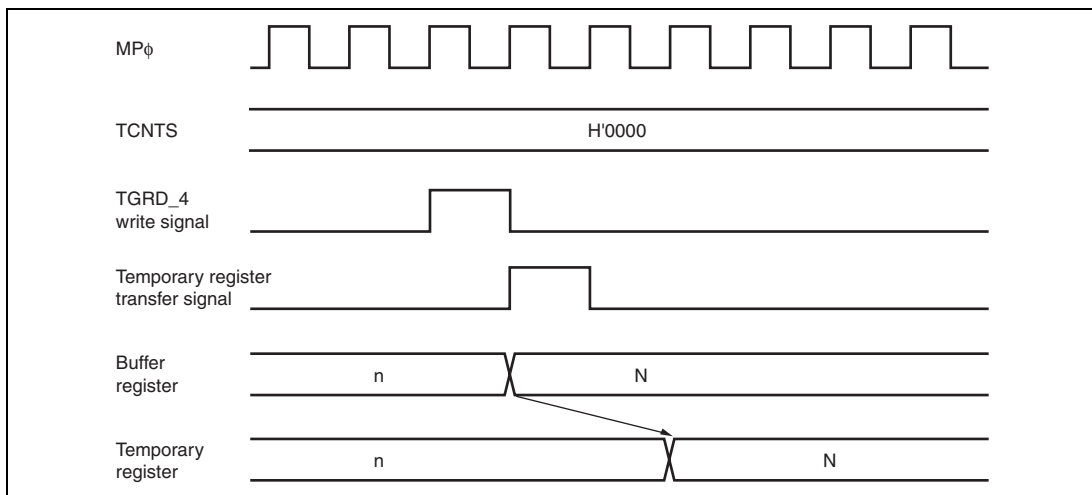

Figure 10.106 Transfer Timing from Buffer Register to Temporary Register (TCNTS Stop)

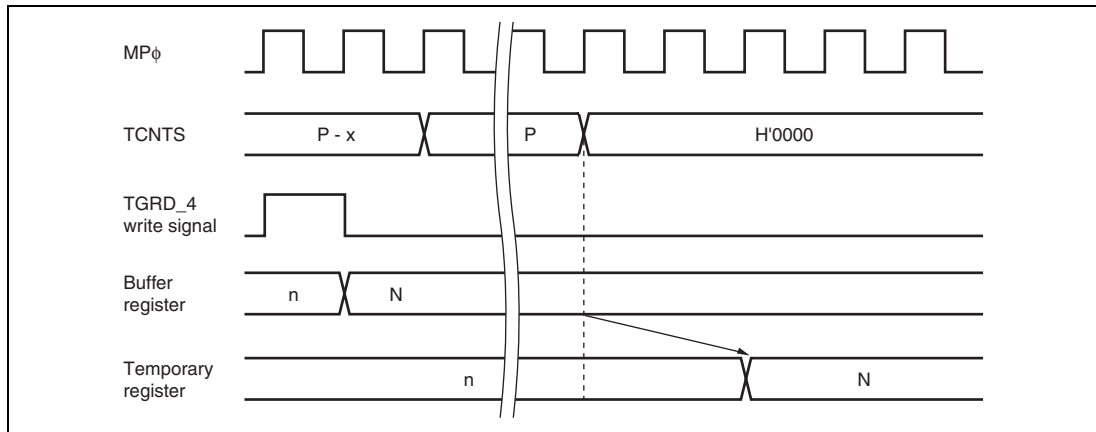

Figure 10.107 Transfer Timing from Buffer Register to Temporary Register (TCNTS Operating)

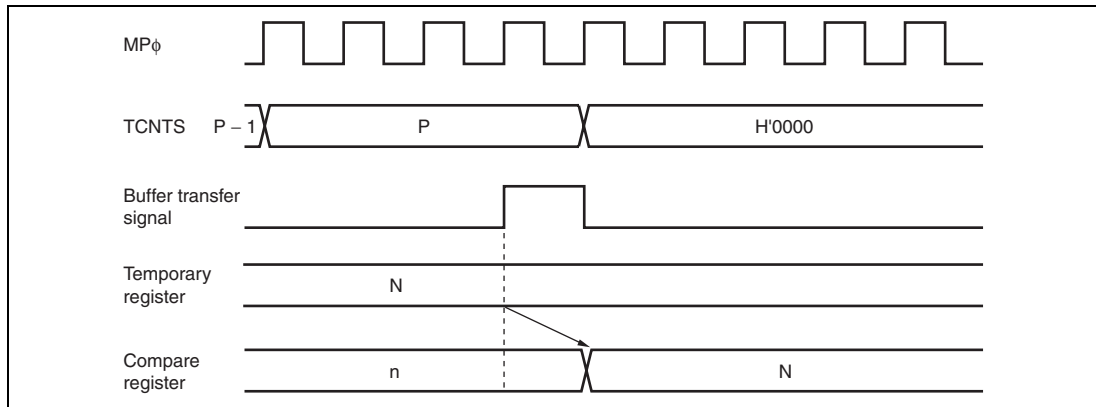

Figure 10.108 Transfer Timing from Temporary Register to Compare Register

10.6.2 Interrupt Signal Timing

TGF Flag Setting Timing in Case of Compare Match: Figures 10.109 and 10.110 show the timing for setting of the TGF flag in TSR on compare match, and TGI interrupt request signal timing.

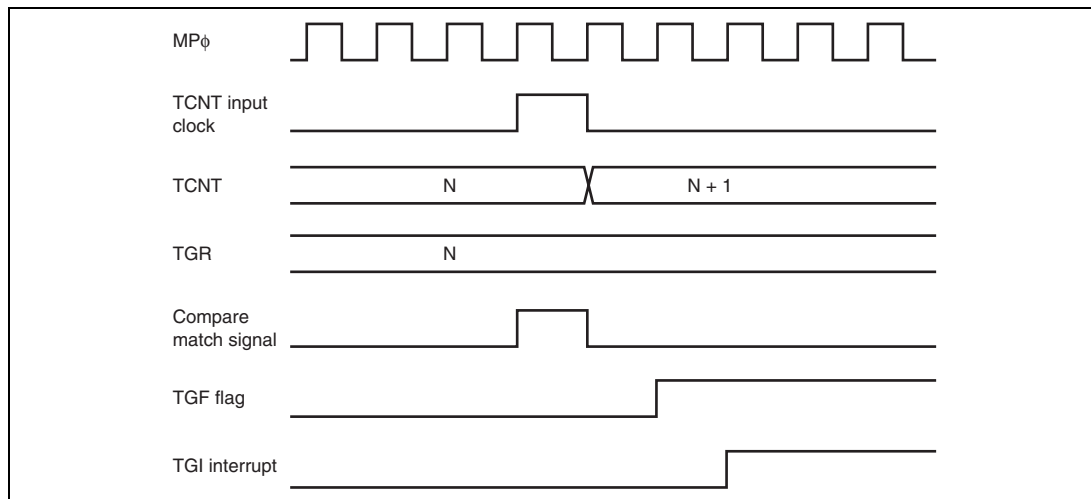

Figure 10.109 TGI Interrupt Timing (Compare Match) (Channels 0 to 4)

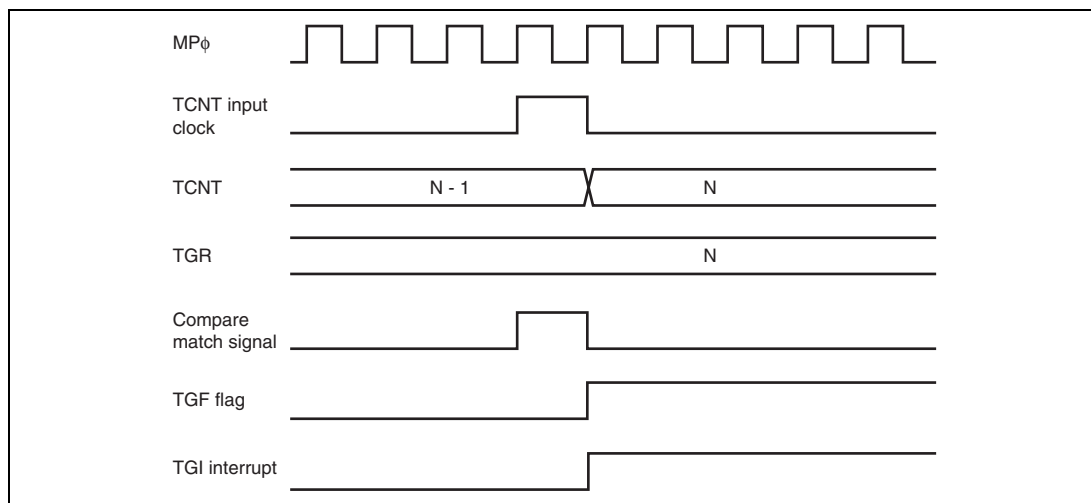

Figure 10.110 TGI Interrupt Timing (Compare Match) (Channel 5)

TGF Flag Setting Timing in Case of Input Capture: Figures 10.111 and 10.112 show the timing for setting of the TGF flag in TSR on input capture, and TGI interrupt request signal timing.

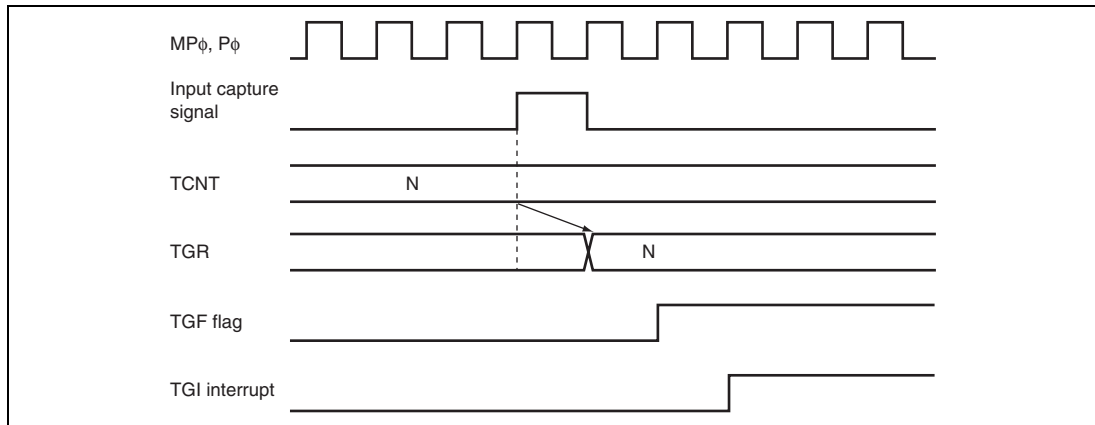

Figure 10.111 TGI Interrupt Timing (Input Capture) (Channels 0 to 4)

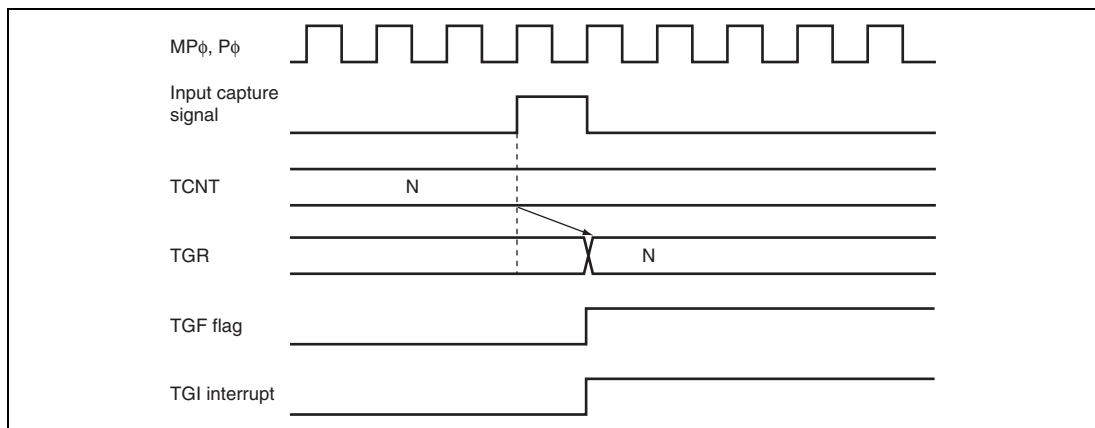

Figure 10.112 TGI Interrupt Timing (Input Capture) (Channel 5)

TCFV Flag/TCFU Flag Setting Timing: Figure 10.113 shows the timing for setting of the TCFV flag in TSR on overflow, and TCIV interrupt request signal timing.

Figure 10.114 shows the timing for setting of the TCFU flag in TSR on underflow, and TCIU interrupt request signal timing.

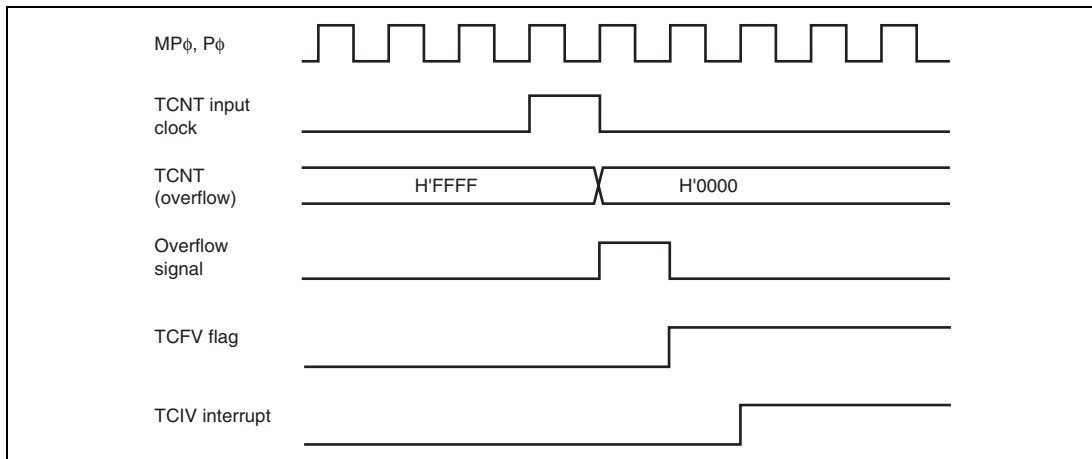

Figure 10.113 TCIV Interrupt Setting Timing

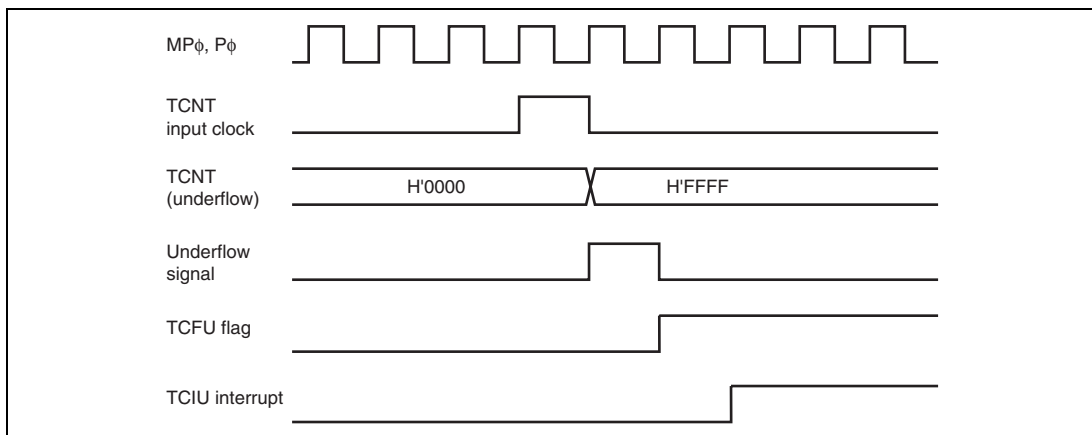

Figure 10.114 TCIU Interrupt Setting Timing

Status Flag Clearing Timing: After a status flag is read as 1 by the CPU, it is cleared by writing 0 to it. When the DTC is activated, the flag is cleared automatically. Figures 10.115 and 10.116 show the timing for status flag clearing by the CPU, and figures 10.117 and 10.118 show the timing for status flag clearing by the DTC.

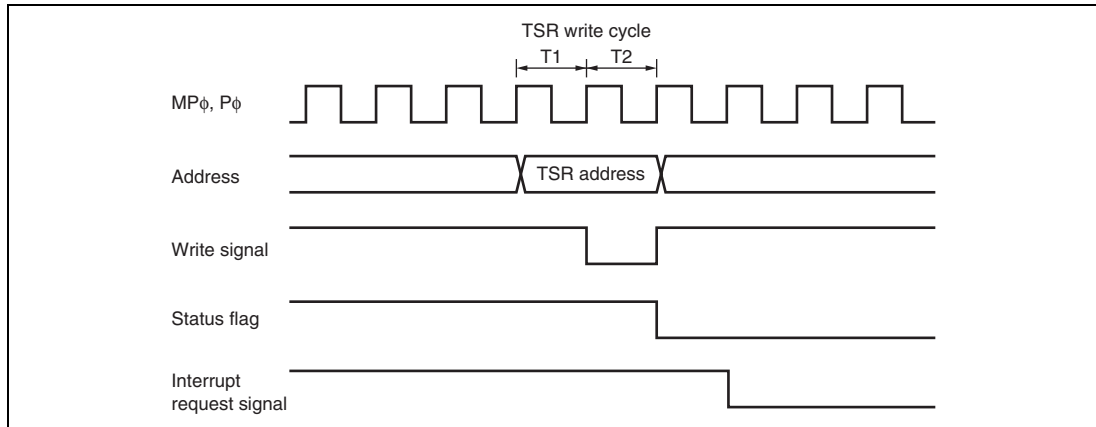

Figure 10.115 Timing for Status Flag Clearing by CPU (Channels 0 to 4)

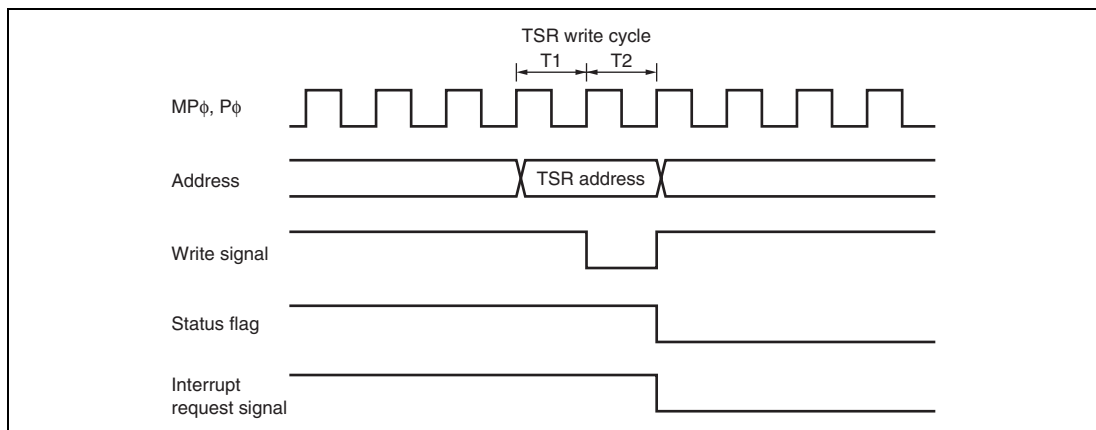

Figure 10.116 Timing for Status Flag Clearing by CPU (Channel 5)

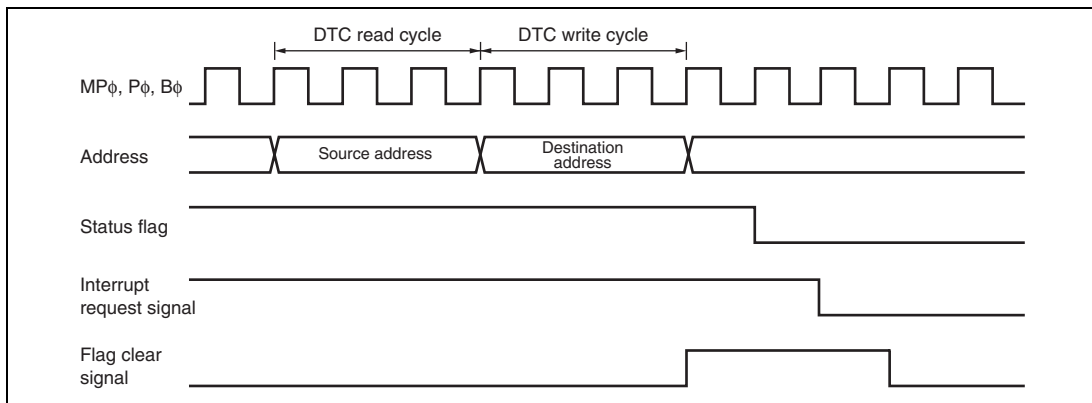

Figure 10.117 Timing for Status Flag Clearing by DTC Activation (Channels 0 to 4)

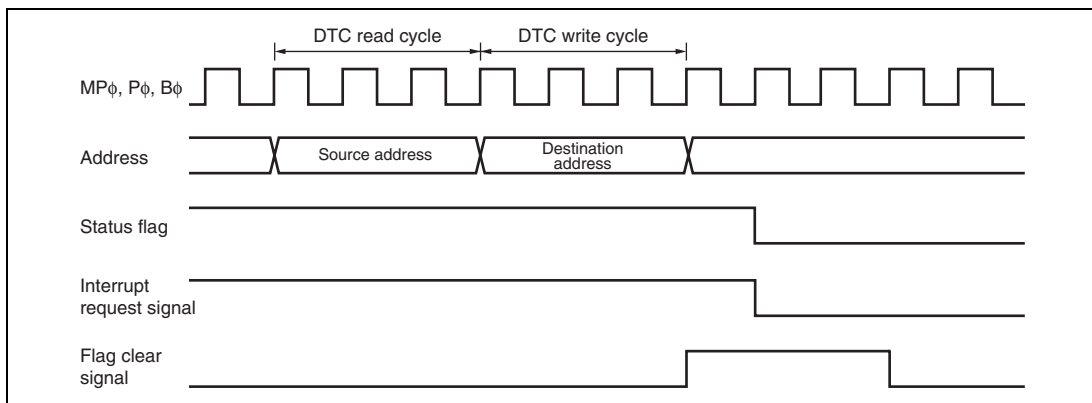

Figure 10.118 Timing for Status Flag Clearing by DTC Activation (Channel 5)

10.7 Usage Notes

10.7.1 Module Standby Mode Setting

MTU2 operation can be disabled or enabled using the standby control register. The initial setting is for MTU2 operation to be halted. Register access is enabled by clearing module standby mode. For details, refer to section 22, Power-Down Modes.

10.7.2 Input Clock Restrictions

The input clock pulse width must be at least 1.5 states in the case of single-edge detection, and at least 2.5 states in the case of both-edge detection. The MTU2 will not operate properly at narrower pulse widths.

In phase counting mode, the phase difference and overlap between the two input clocks must be at least 1.5 states, and the pulse width must be at least 2.5 states. Figure 10.119 shows the input clock conditions in phase counting mode.

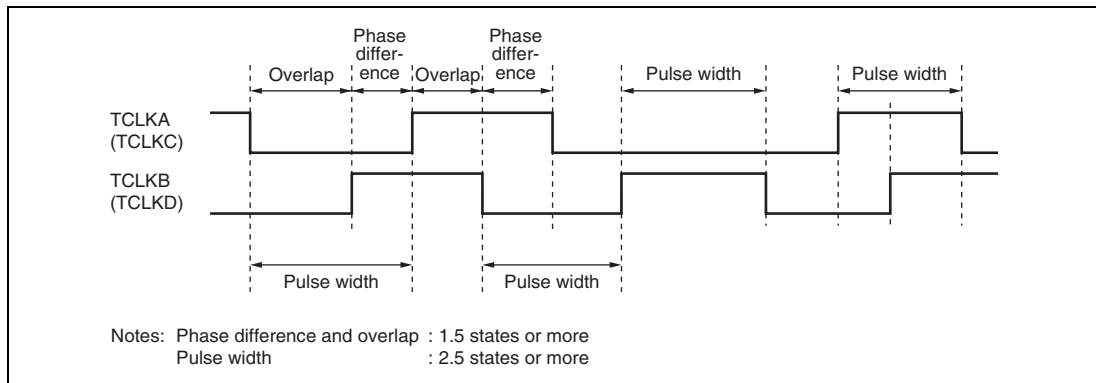

Figure 10.119 Phase Difference, Overlap, and Pulse Width in Phase Counting Mode

10.7.3 Caution on Period Setting

When counter clearing on compare match is set, TCNT is cleared in the final state in which it matches the TGR value (the point at which the count value matched by TCNT is updated). Consequently, the actual counter frequency is given by the following formula:

- Channels 0 to 4

$$f = \frac{MP\phi}{(N + 1)}$$

- Channel 5

$$f = \frac{MP\phi}{N}$$

Where

- f: Counter frequency
- MP ϕ : MTU2 peripheral clock operating frequency
- N: TGR set value

10.7.4 Contention between TCNT Write and Clear Operations

If the counter clear signal is generated in the T2 state of a TCNT write cycle, TCNT clearing takes precedence and the TCNT write is not performed.

Figure 10.120 shows the timing in this case.

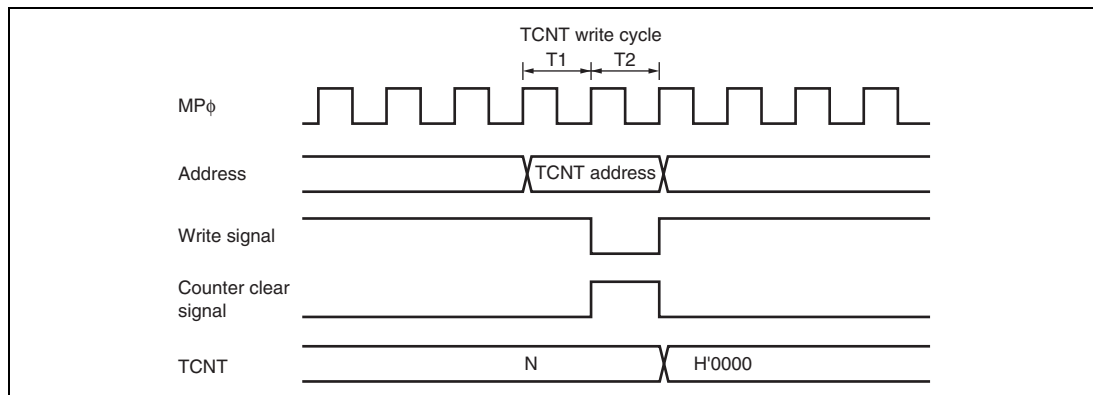

Figure 10.120 Contention between TCNT Write and Clear Operations

10.7.5 Contention between TCNT Write and Increment Operations

If incrementing occurs in the T2 state of a TCNT write cycle, the TCNT write takes precedence and TCNT is not incremented.

Figure 10.121 shows the timing in this case.

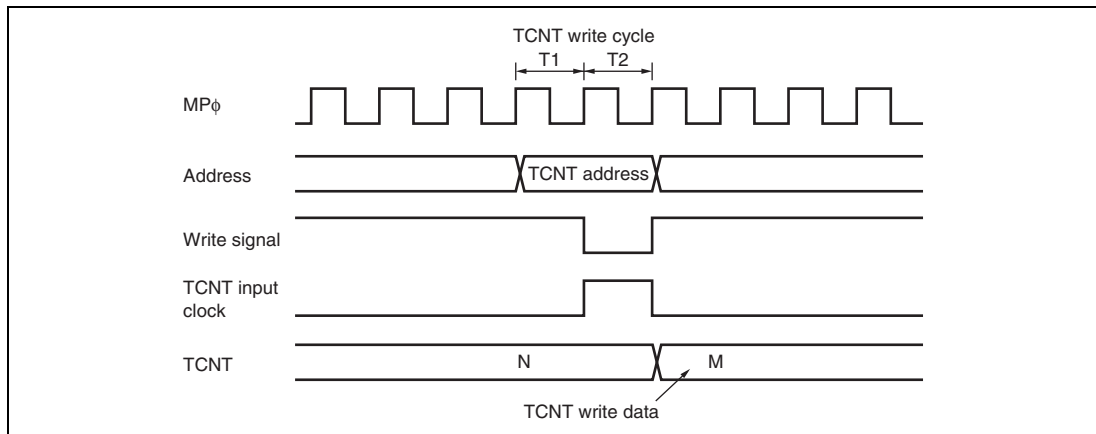

Figure 10.121 Contention between TCNT Write and Increment Operations

10.7.6 Contention between TGR Write and Compare Match

If a compare match occurs in the T2 state of a TGR write cycle, the TGR write is executed and the compare match signal is also generated.

Figure 10.122 shows the timing in this case.

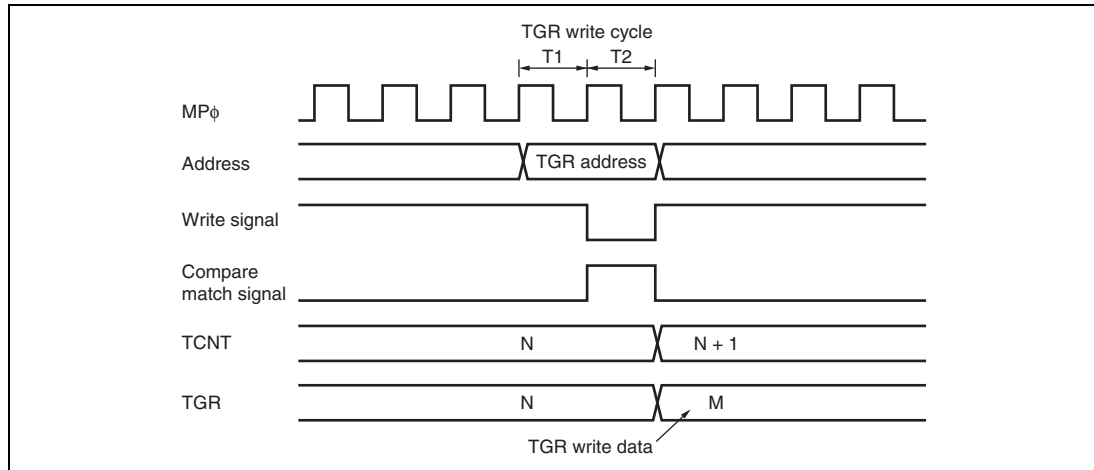

Figure 10.122 Contention between TGR Write and Compare Match

10.7.7 Contention between Buffer Register Write and Compare Match

If a compare match occurs in the T2 state of a TGR write cycle, the data that is transferred to TGR by the buffer operation is the data before write.

Figure 10.123 shows the timing in this case.

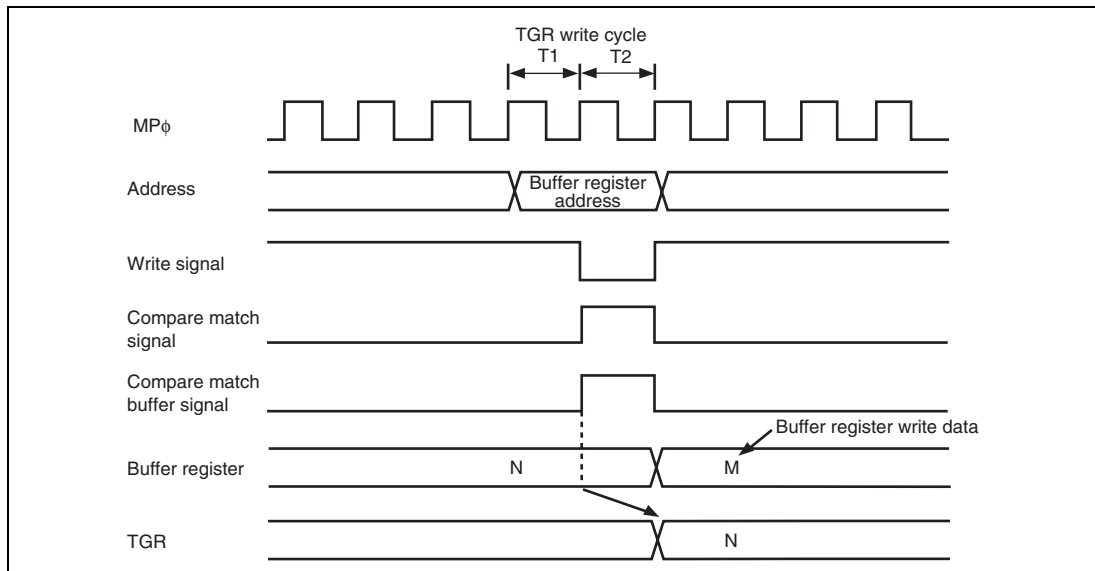

Figure 10.123 Contention between Buffer Register Write and Compare Match

10.7.8 Contention between Buffer Register Write and TCNT Clear

When the buffer transfer timing is set at the TCNT clear by the buffer transfer mode register (TBTM), if TCNT clear occurs in the T2 state of a TGR write cycle, the data that is transferred to TGR by the buffer operation is the data before write.

Figure 10.124 shows the timing in this case.

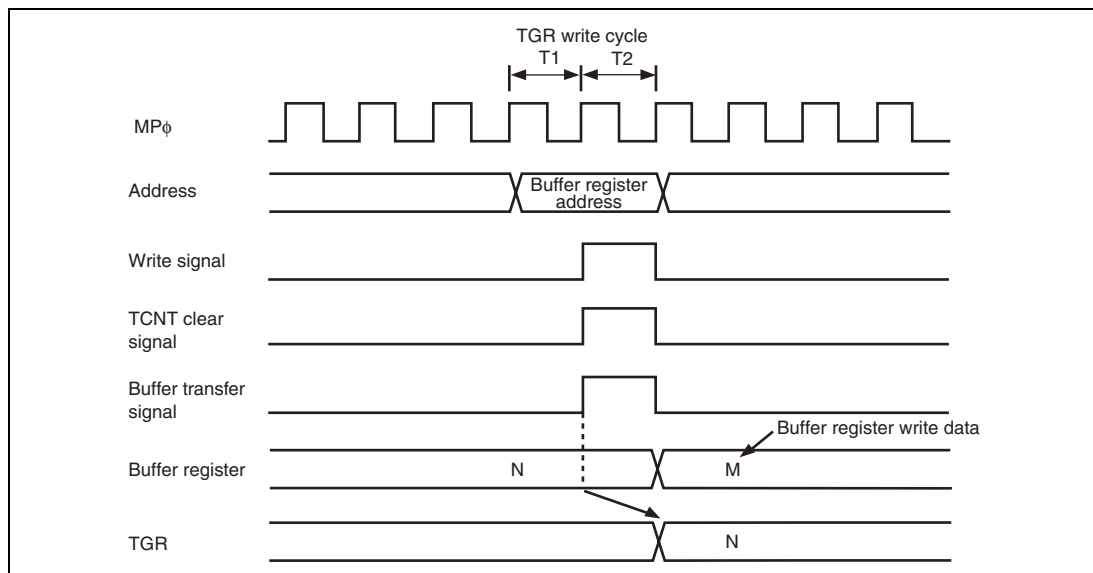

Figure 10.124 Contention between Buffer Register Write and TCNT Clear

10.7.9 Contention between TGR Read and Input Capture

If an input capture signal is generated in the T1 state of a TGR read cycle, the data that is read will be the data in the buffer before input capture transfer for channels 0 to 4, and the data after input capture transfer for channel 5.

Figures 10.125 and 10.126 show the timing in this case.

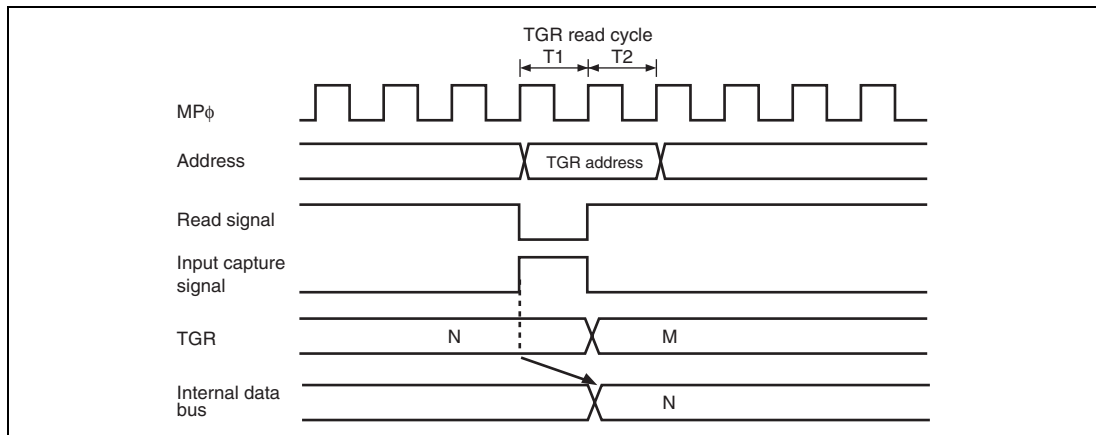

Figure 10.125 Contention between TGR Read and Input Capture (Channels 0 to 4)

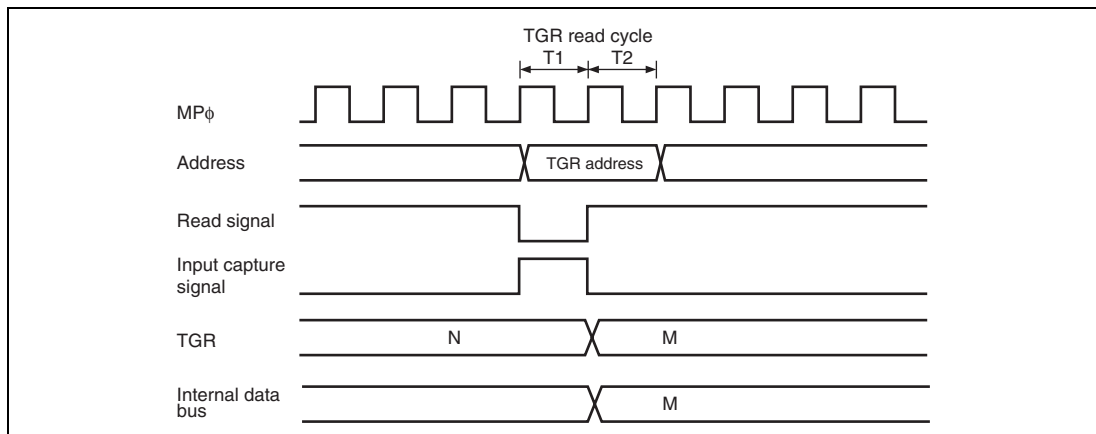

Figure 10.126 Contention between TGR Read and Input Capture (Channel 5)

10.7.10 Contention between TGR Write and Input Capture

If an input capture signal is generated in the T2 state of a TGR write cycle, the input capture operation takes precedence and the write to TGR is not performed for channels 0 to 4. For channel 5, write to TGR is performed and the input capture signal is generated.

Figures 10.127 and 10.128 show the timing in this case.

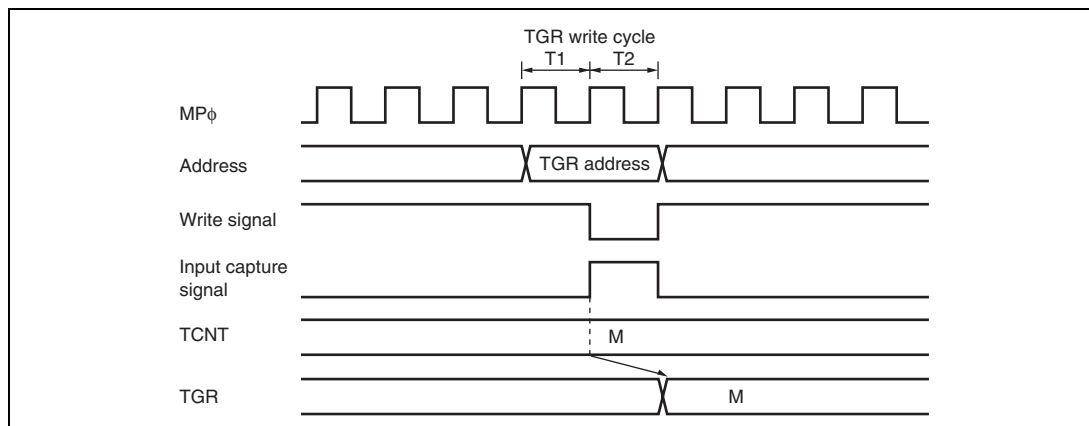

Figure 10.127 Contention between TGR Write and Input Capture (Channels 0 to 4)

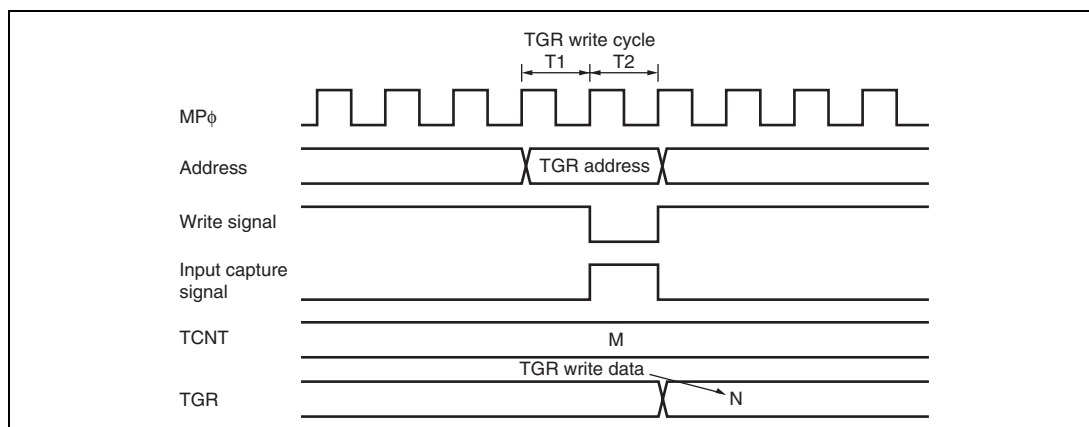

Figure 10.128 Contention between TGR Write and Input Capture (Channel 5)

10.7.11 Contention between Buffer Register Write and Input Capture

If an input capture signal is generated in the T2 state of a buffer register write cycle, the buffer operation takes precedence and the write to the buffer register is not performed.

Figure 10.129 shows the timing in this case.

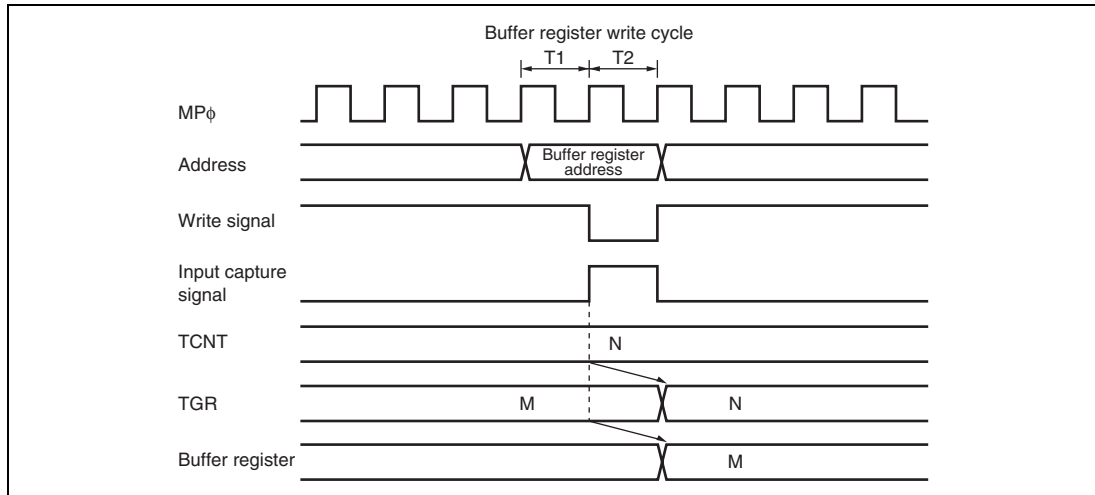

Figure 10.129 Contention between Buffer Register Write and Input Capture

10.7.12 TCNT_2 Write and Overflow/Underflow Contention in Cascade Connection

With timer counters TCNT_1 and TCNT_2 in a cascade connection, when a contention occurs during TCNT_1 count (during a TCNT_2 overflow/underflow) in the T2 state of the TCNT_2 write cycle, the write to TCNT_2 is conducted, and the TCNT_1 count signal is disabled. At this point, if there is match with TGRA_1 and the TCNT_1 value, a compare signal is issued. Furthermore, when the TCNT_1 count clock is selected as the input capture source of channel 0, TGRA_0 to TGRD_0 carry out the input capture operation. In addition, when the compare match/input capture is selected as the input capture source of TGRB_1, TGRB_1 carries out input capture operation. The timing is shown in figure 10.130.

For cascade connections, be sure to synchronize settings for channels 1 and 2 when setting TCNT clearing.

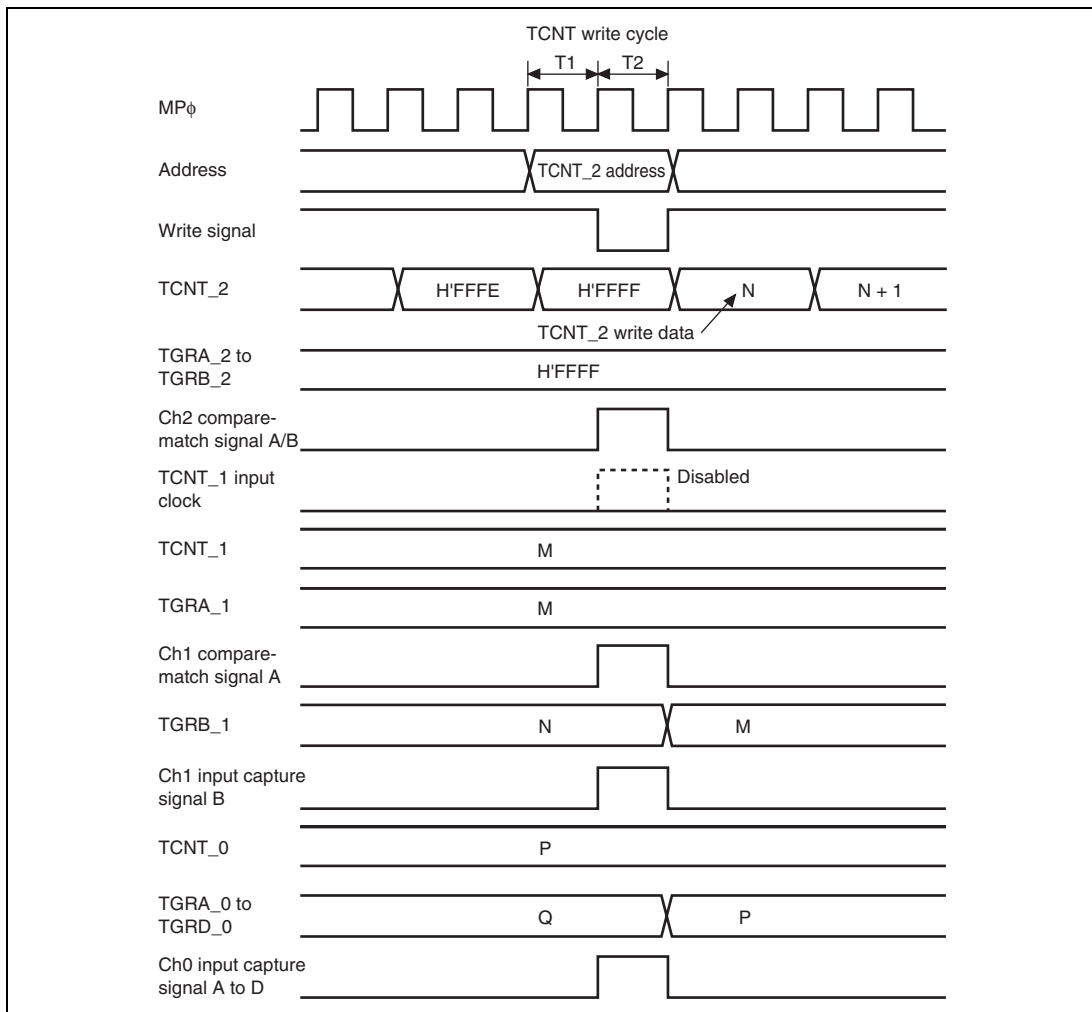

Figure 10.130 TCNT_2 Write and Overflow/Underflow Contention with Cascade Connection

10.7.13 Counter Value during Complementary PWM Mode Stop

When counting operation is suspended with TCNT_3 and TCNT_4 in complementary PWM mode, TCNT_3 has the timer dead time register (TDDR) value, and TCNT_4 is held at H'0000.

When restarting complementary PWM mode, counting begins automatically from the initialized state. This explanatory diagram is shown in figure 10.131.

When counting begins in another operating mode, be sure that TCNT_3 and TCNT_4 are set to the initial values.

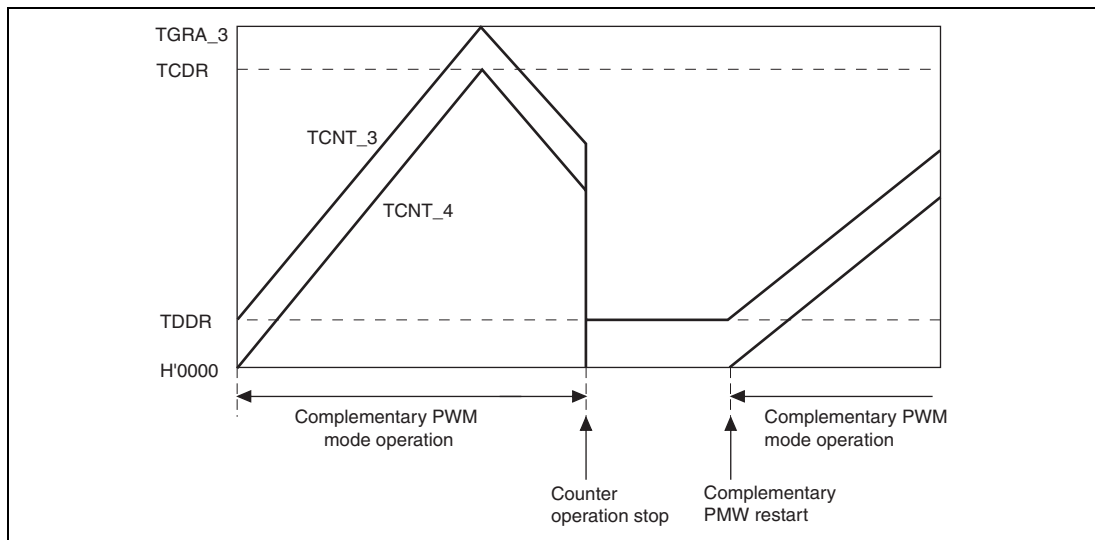

Figure 10.131 Counter Value during Complementary PWM Mode Stop

10.7.14 Buffer Operation Setting in Complementary PWM Mode

In complementary PWM mode, conduct rewrites by buffer operation for the PWM cycle setting register (TGRA_3), timer cycle data register (TCDR), and duty setting registers (TGRB_3, TGRA_4, and TGRB_4).

In complementary PWM mode, channel 3 and channel 4 buffers operate in accordance with bit settings BFA and BFB of TMDR_3. When TMDR_3's BFA bit is set to 1, TGRC_3 functions as a buffer register for TGRA_3. At the same time, TGRC_4 functions as the buffer register for TGRA_4, and TCBR functions as the TCDR's buffer register.

10.7.15 Reset Sync PWM Mode Buffer Operation and Compare Match Flag

When setting buffer operation for reset sync PWM mode, set the BFA and BFB bits in TMDR_4 to 0. The TIOC4C pin will be unable to produce its waveform output if the BFA bit in TMDR_4 is set to 1.

In reset sync PWM mode, the channel 3 and channel 4 buffers operate in accordance with the BFA and BFB bit settings of TMDR_3. For example, if the BFA bit in TMDR_3 is set to 1, TGRC_3 functions as the buffer register for TGRA_3. At the same time, TGRC_4 functions as the buffer register for TGRA_4.

The TGFC bit and TGFD bit in TSR_3 and TSR_4 are not set when TGRC_3 and TGRD_3 are operating as buffer registers.

Figure 10.132 shows an example of operations for TGR_3, TGR_4, TIOC3, and TIOC4, with TMDR_3's BFA and BFB bits set to 1, and TMDR_4's BFA and BFB bits set to 0.

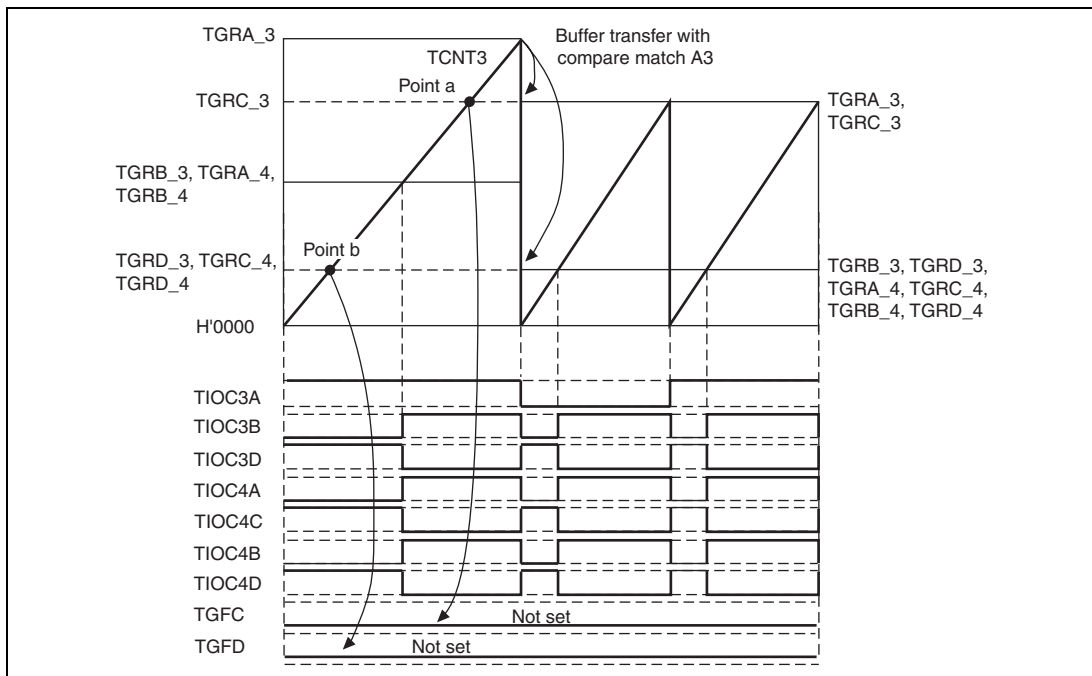

Figure 10.132 Buffer Operation and Compare-Match Flags in Reset Synchronous PWM Mode

10.7.16 Overflow Flags in Reset Synchronous PWM Mode

When set to reset synchronous PWM mode, TCNT_3 and TCNT_4 start counting when the CST3 bit of TSTR is set to 1. At this point, TCNT_4's count clock source and count edge obey the TCR_3 setting.

In reset synchronous PWM mode, with cycle register TGRA_3's set value at H'FFFF, when specifying TGR3A compare-match for the counter clear source, TCNT_3 and TCNT_4 count up to H'FFFF, then a compare-match occurs with TGRA_3, and TCNT_3 and TCNT_4 are both cleared. At this point, TSR's overflow flag TCFV bit is not set.

Figure 10.133 shows a TCFV bit operation example in reset synchronous PWM mode with a set value for cycle register TGRA_3 of H'FFFF, when a TGRA_3 compare-match has been specified without synchronous setting for the counter clear source.

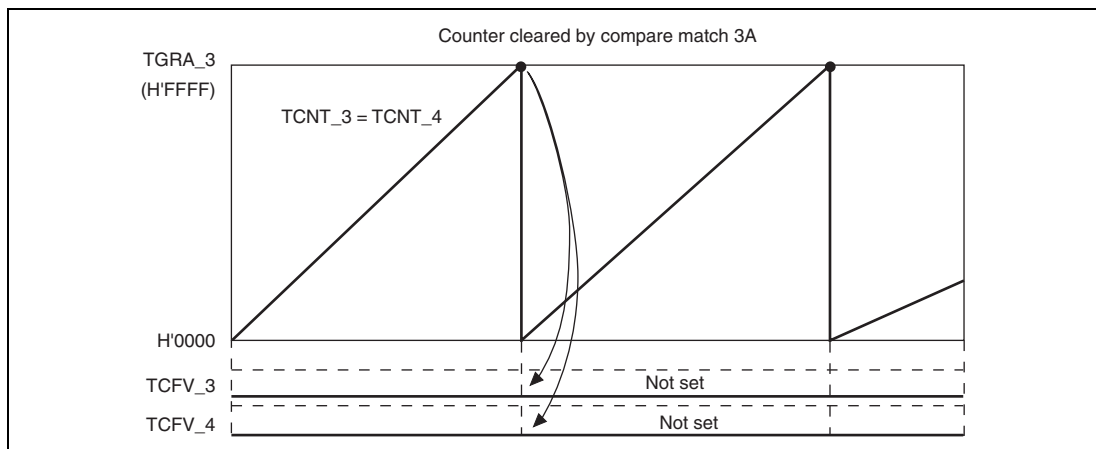

Figure 10.133 Reset Synchronous PWM Mode Overflow Flag

10.7.17 Contention between Overflow/Underflow and Counter Clearing

If overflow/underflow and counter clearing occur simultaneously, the TCFV/TCFU flag in TSR is not set and TCNT clearing takes precedence.

Figure 10.134 shows the operation timing when a TGR compare match is specified as the clearing source, and when H'FFFF is set in TGR.

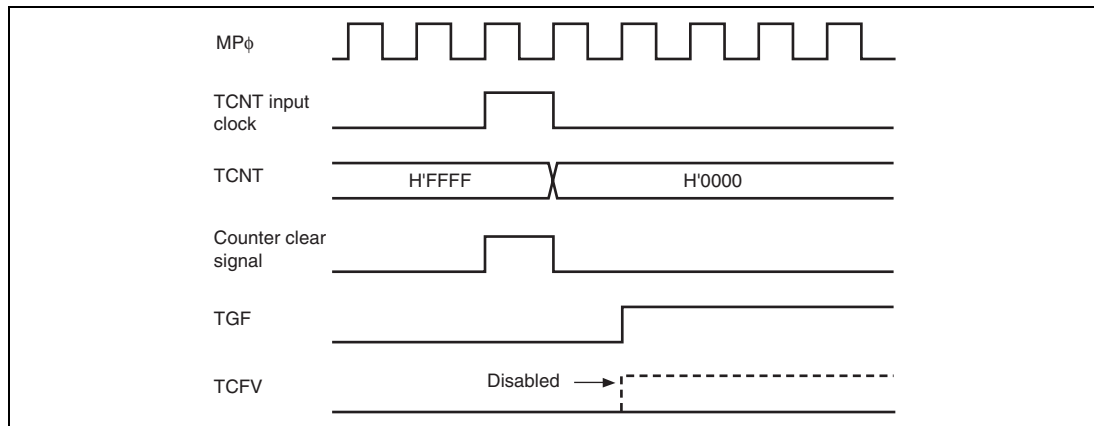

Figure 10.134 Contention between Overflow and Counter Clearing

10.7.18 Contention between TCNT Write and Overflow/Underflow

If there is an up-count or down-count in the T2 state of a TCNT write cycle, and overflow/underflow occurs, the TCNT write takes precedence and the TCFV/TCFU flag in TSR is not set.

Figure 10.135 shows the operation timing when there is contention between TCNT write and overflow.

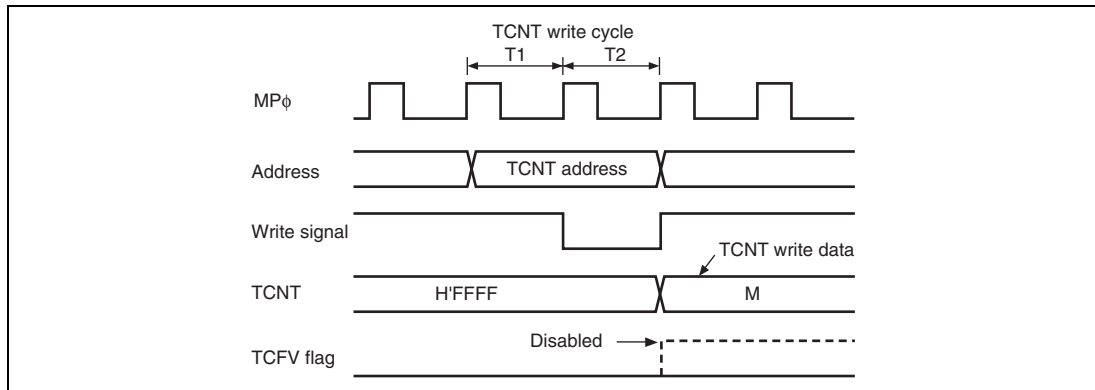

Figure 10.135 Contention between TCNT Write and Overflow

10.7.19 Cautions on Transition from Normal Operation or PWM Mode 1 to Reset-Synchronized PWM Mode

When making a transition from channel 3 or 4 normal operation or PWM mode 1 to reset-synchronized PWM mode, if the counter is halted with the output pins (TIOC3B, TIOC3D, TIOC4A, TIOC4C, TIOC4B, TIOC4D) in the high-level state, followed by the transition to reset-synchronized PWM mode and operation in that mode, the initial pin output will not be correct.

When making a transition from normal operation to reset-synchronized PWM mode, write H'11 to registers TIORH_3, TIORL_3, TIORH_4, and TIORL_4 to initialize the output pins to low level output, then set an initial register value of H'00 before making the mode transition.

When making a transition from PWM mode 1 to reset-synchronized PWM mode, first switch to normal operation, then initialize the output pins to low level output and set an initial register value of H'00 before making the transition to reset-synchronized PWM mode.

10.7.20 Output Level in Complementary PWM Mode and Reset-Synchronized PWM Mode

When channels 3 and 4 are in complementary PWM mode or reset-synchronized PWM mode, the PWM waveform output level is set with the OLSP and OLSN bits in the timer output control register (TOCR). In the case of complementary PWM mode or reset-synchronized PWM mode, TIOR should be set to H'00.

10.7.21 Interrupts in Module Standby Mode

If module standby mode is entered when an interrupt has been requested, it will not be possible to clear the CPU interrupt source or the DTC activation source. Interrupts should therefore be disabled before entering module standby mode.

10.7.22 Simultaneous Capture of TCNT_1 and TCNT_2 in Cascade Connection

When timer counters 1 and 2 (TCNT_1 and TCNT_2) are operated as a 32-bit counter in cascade connection, the cascade counter value cannot be captured successfully even if input-capture input is simultaneously done to TIOC1A and TIOC2A or to TIOC1B and TIOC2B. This is because the input timing of TIOC1A and TIOC2A or of TIOC1B and TIOC2B may not be the same when external input-capture signals to be input into TCNT_1 and TCNT_2 are taken in synchronization with the internal clock. For example, TCNT_1 (the counter for upper 16 bits) does not capture the count-up value by overflow from TCNT_2 (the counter for lower 16 bits) but captures the count value before the count-up. In this case, the values of TCNT_1 = H'FFF1 and TCNT_2 = H'0000 should be transferred to TGRA_1 and TGRA_2 or to TGRB_1 and TGRB_2, but the values of TCNT_1 = H'FFF0 and TCNT_2 = H'0000 are erroneously transferred.

The MTU2 has a function that allows simultaneous capture of TCNT_1 and TCNT_2 with a single input-capture input as the trigger. This function allows reading of the 32-bit counter such that TCNT_1 and TCNT_2 are captured at the same time. For details, see section, 10.3.8, Timer Input Capture Control Register (TICCR).

10.7.23 Notes on Output Waveform Control During Synchronous Counter Clearing in Complementary PWM Mode

In complementary PWM mode, when output waveform control during synchronous counter clearing is enabled (WRE in the TWCR register set to 1), the following problems may occur when condition (1) or condition (2), below, is satisfied.

- Dead time for the PWM output pins may be too short (or nonexistent).
- Active-level output from the PWM negative-phase pins may occur outside the correct active-level output interval

Condition (1): When synchronous clearing occurs in the PWM output dead time interval within initial output suppression interval (10) (figure 10.136).

Condition (2): When synchronous clearing occurs within initial output suppression interval (10) or (11) and $TGRB_3 \leq TDDR$, $TGRA_4 \leq TDDR$, or $TGRB_4 \leq TDDR$ is true (figure 10.137).

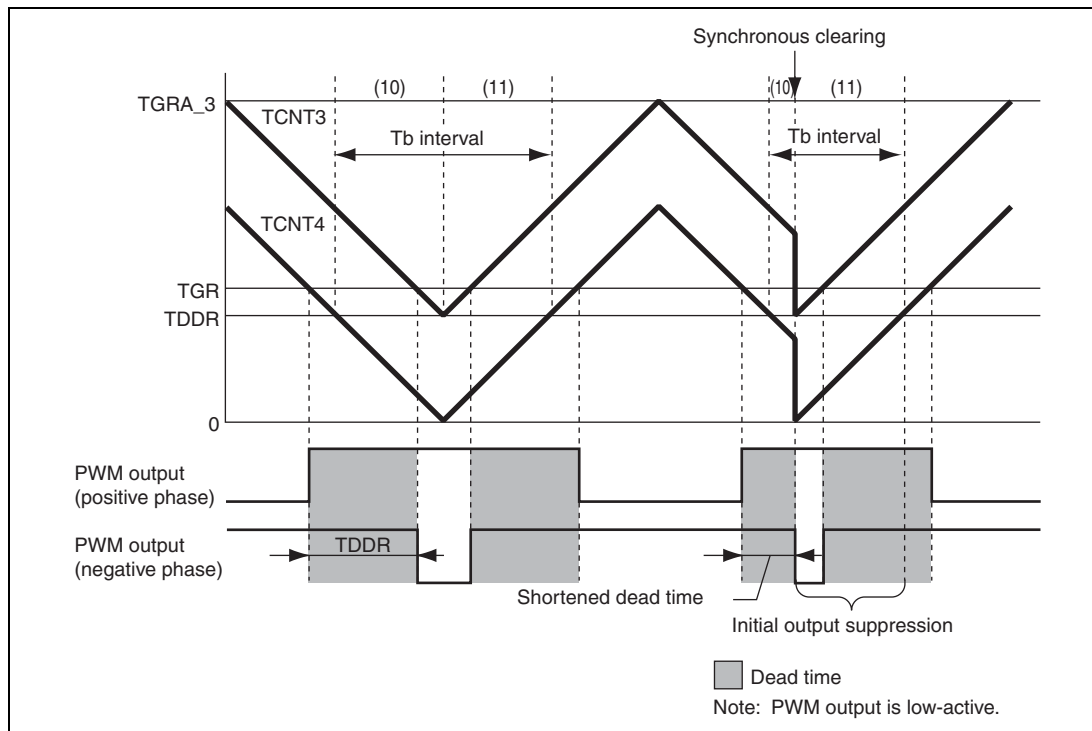

Figure 10.136 Condition (1) Synchronous Clearing Example

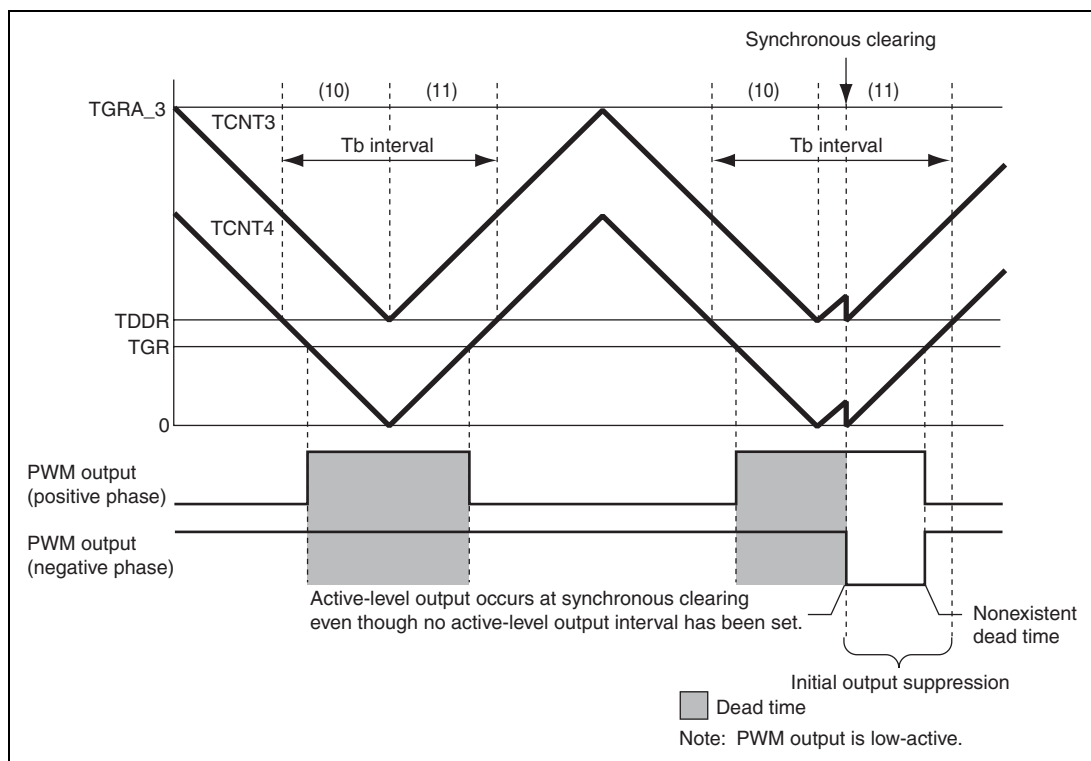

Figure 10.137 Condition (2) Synchronous Clearing Example

The following workaround can be used to avoid these problems.

When using synchronous clearing, make sure to set compare registers TGRB_3, TGRA_4, and TGRB_4 to a value twice or more the setting of dead time data register TDDR.

10.8 MTU2 Output Pin Initialization

10.8.1 Operating Modes

The MTU2 has the following six operating modes. Waveform output is possible in all of these modes.

- Normal mode (channels 0 to 4)
- PWM mode 1 (channels 0 to 4)
- PWM mode 2 (channels 0 to 2)
- Phase counting modes 1 to 4 (channels 1 and 2)
- Complementary PWM mode (channels 3 and 4)
- Reset-synchronized PWM mode (channels 3 and 4)

The MTU2 output pin initialization method for each of these modes is described in this section.

10.8.2 Reset Start Operation

The MTU2 output pins (TIOC*) are initialized low by a reset and in standby mode. Since MTU2 pin function selection is performed by the pin function controller (PFC), when the PFC is set, the MTU2 pin states at that point are output to the ports. When MTU2 output is selected by the PFC immediately after a reset, the MTU2 output initial level, low, is output directly at the port. When the active level is low, the system will operate at this point, and therefore the PFC setting should be made after initialization of the MTU2 output pins is completed.

Note: Channel number and port notation are substituted for *.

10.8.3 Operation in Case of Re-Setting Due to Error During Operation, etc.

If an error occurs during MTU2 operation, MTU2 output should be cut by the system. Cutoff is performed by switching the pin output to port output with the PFC and outputting the inverse of the active level. For large-current pins, output can also be cut by hardware, using port output enable (POE). The pin initialization procedures for re-setting due to an error during operation, etc., and the procedures for restarting in a different mode after re-setting, are shown below.

The MTU2 has six operating modes, as stated above. There are thus 36 mode transition combinations, but some transitions are not available with certain channel and mode combinations. Possible mode transition combinations are shown in table 10.59.

Table 10.59 Mode Transition Combinations

Before	After					
	Normal	PWM1	PWM2	PCM	CPWM	RPWM
Normal	(1)	(2)	(3)	(4)	(5)	(6)
PWM1	(7)	(8)	(9)	(10)	(11)	(12)
PWM2	(13)	(14)	(15)	(16)	None	None
PCM	(17)	(18)	(19)	(20)	None	None
CPWM	(21)	(22)	None	None	(23) (24)	(25)
RPWM	(26)	(27)	None	None	(28)	(29)

[Legend]

Normal: Normal mode

PWM1: PWM mode 1

PWM2: PWM mode 2

PCM: Phase counting modes 1 to 4

CPWM: Complementary PWM mode

RPWM: Reset-synchronized PWM mode

10.8.4 Overview of Initialization Procedures and Mode Transitions in Case of Error during Operation, etc.

- When making a transition to a mode (Normal, PWM1, PWM2, PCM) in which the pin output level is selected by the timer I/O control register (TIOR) setting, initialize the pins by means of a TIOR setting.
- In PWM mode 1, since a waveform is not output to the TIOC*B (TIOC *D) pin, setting TIOR will not initialize the pins. If initialization is required, carry it out in normal mode, then switch to PWM mode 1.
- In PWM mode 2, since a waveform is not output to the cycle register pin, setting TIOR will not initialize the pins. If initialization is required, carry it out in normal mode, then switch to PWM mode 2.
- In normal mode or PWM mode 2, if TGRC and TGRD operate as buffer registers, setting TIOR will not initialize the buffer register pins. If initialization is required, clear buffer mode, carry out initialization, then set buffer mode again.
- In PWM mode 1, if either TGRC or TGRD operates as a buffer register, setting TIOR will not initialize the TGRC pin. To initialize the TGRC pin, clear buffer mode, carry out initialization, then set buffer mode again.
- When making a transition to a mode (CPWM, RPWM) in which the pin output level is selected by the timer output control register (TOCR) setting, switch to normal mode and perform initialization with TIOR, then restore TIOR to its initial value, and temporarily disable channel 3 and 4 output with the timer output master enable register (TOER). Then operate the unit in accordance with the mode setting procedure (TOCR setting, TMDR setting, TOER setting).

Note: Channel number is substituted for * indicated in this article.

Pin initialization procedures are described below for the numbered combinations in table 10.59. The active level is assumed to be low.

Operation when Error Occurs during Normal Mode Operation, and Operation is Restarted in Normal Mode: Figure 10.138 shows an explanatory diagram of the case where an error occurs in normal mode and operation is restarted in normal mode after re-setting.

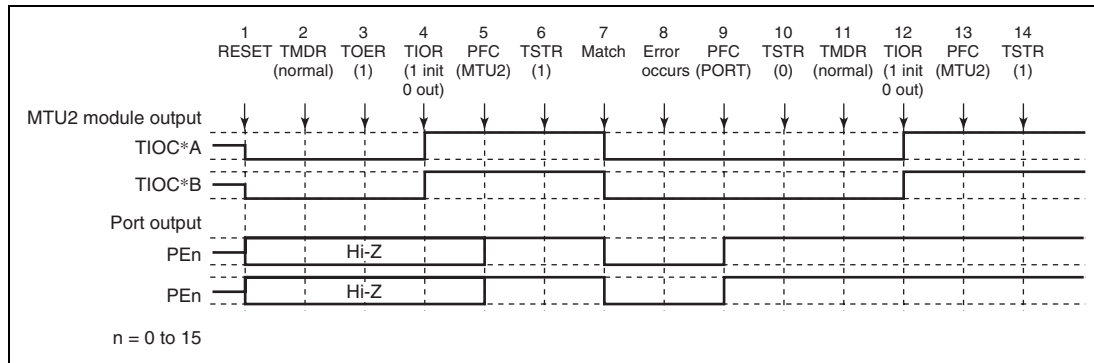

Figure 10.138 Error Occurrence in Normal Mode, Recovery in Normal Mode

1. After a reset, MTU2 output is low and ports are in the high-impedance state.
2. After a reset, the TMDR setting is for normal mode.
3. For channels 3 and 4, enable output with TOER before initializing the pins with TIOR.
4. Initialize the pins with TIOR. (The example shows initial high output, with low output on compare-match occurrence.)
5. Set MTU2 output with the PFC.
6. The count operation is started by TSTR.
7. Output goes low on compare-match occurrence.
8. An error occurs.
9. Set port output with the PFC and output the inverse of the active level.
10. The count operation is stopped by TSTR.
11. Not necessary when restarting in normal mode.
12. Initialize the pins with TIOR.
13. Set MTU2 output with the PFC.
14. Operation is restarted by TSTR.

Operation when Error Occurs during Normal Mode Operation, and Operation is Restarted in PWM Mode 1: Figure 10.139 shows an explanatory diagram of the case where an error occurs in normal mode and operation is restarted in PWM mode 1 after re-setting.

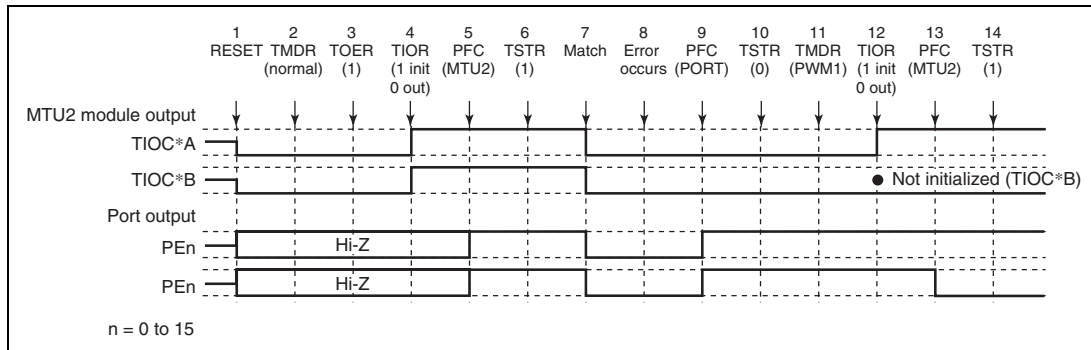

Figure 10.139 Error Occurrence in Normal Mode, Recovery in PWM Mode 1

1 to 10 are the same as in figure 10.138.

11. Set PWM mode 1.
12. Initialize the pins with TIOR. (In PWM mode 1, the TIOC*B side is not initialized. If initialization is required, initialize in normal mode, then switch to PWM mode 1.)
13. Set MTU2 output with the PFC.
14. Operation is restarted by TSTR.

Operation when Error Occurs during Normal Mode Operation, and Operation is Restarted in PWM Mode 2: Figure 10.140 shows an explanatory diagram of the case where an error occurs in normal mode and operation is restarted in PWM mode 2 after re-setting.

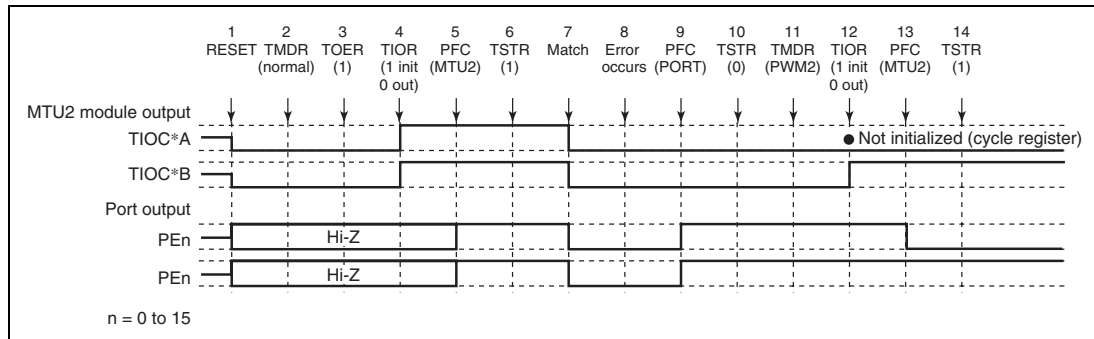

Figure 10.140 Error Occurrence in Normal Mode, Recovery in PWM Mode 2

1 to 10 are the same as in figure 10.138.

11. Set PWM mode 2.
12. Initialize the pins with TIOR. (In PWM mode 2, the cycle register pins are not initialized. If initialization is required, initialize in normal mode, then switch to PWM mode 2.)
13. Set MTU2 output with the PFC.
14. Operation is restarted by TSTR.

Note: PWM mode 2 can only be set for channels 0 to 2, and therefore TOER setting is not necessary.

Operation when Error Occurs during Normal Mode Operation, and Operation is Restarted in Phase Counting Mode: Figure 10.141 shows an explanatory diagram of the case where an error occurs in normal mode and operation is restarted in phase counting mode after re-setting.

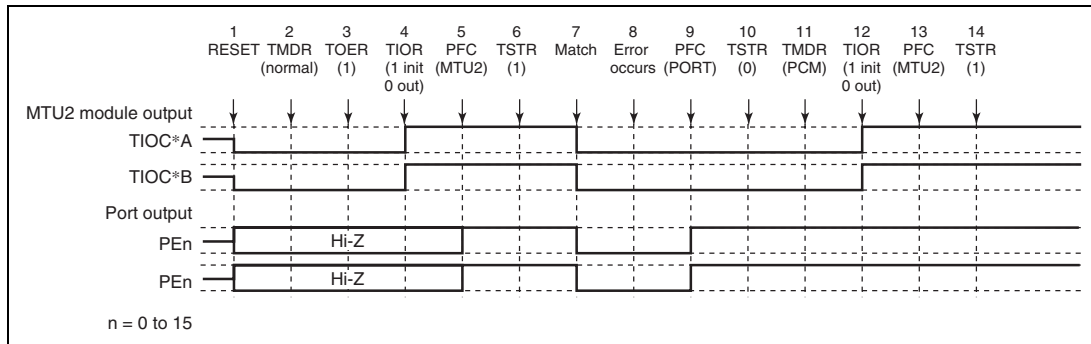

Figure 10.141 Error Occurrence in Normal Mode, Recovery in Phase Counting Mode

1 to 10 are the same as in figure 10.138.

11. Set phase counting mode.
12. Initialize the pins with TIOR.
13. Set MTU2 output with the PFC.
14. Operation is restarted by TSTR.

Note: Phase counting mode can only be set for channels 1 and 2, and therefore TOER setting is not necessary.

Operation when Error Occurs during Normal Mode Operation, and Operation is Restarted in Complementary PWM Mode: Figure 10.142 shows an explanatory diagram of the case where an error occurs in normal mode and operation is restarted in complementary PWM mode after re-setting.

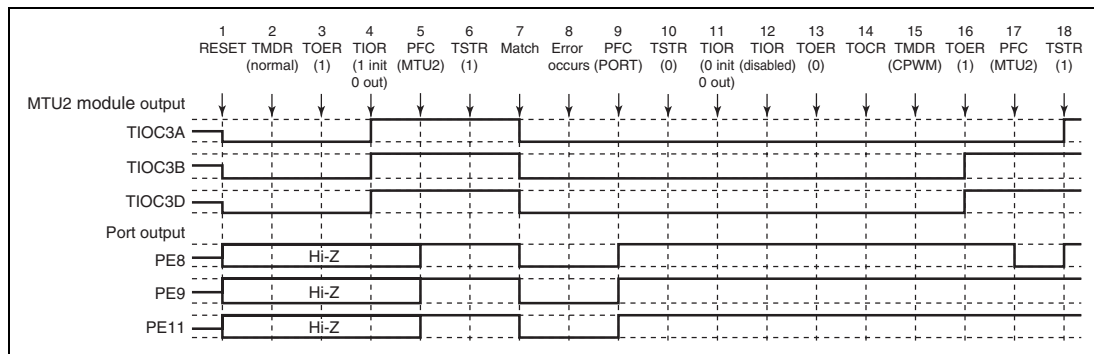

**Figure 10.142 Error Occurrence in Normal Mode,
Recovery in Complementary PWM Mode**

1 to 10 are the same as in figure 10.138.

11. Initialize the normal mode waveform generation section with TIOR.
12. Disable operation of the normal mode waveform generation section with TIOR.
13. Disable channel 3 and 4 output with TOER.
14. Select the complementary PWM output level and cyclic output enabling/disabling with TOCR.
15. Set complementary PWM.
16. Enable channel 3 and 4 output with TOER.
17. Set MTU2 output with the PFC.
18. Operation is restarted by TSTR.

Operation when Error Occurs during Normal Mode Operation, and Operation is Restarted in Reset-Synchronized PWM Mode: Figure 10.143 shows an explanatory diagram of the case where an error occurs in normal mode and operation is restarted in reset-synchronized PWM mode after re-setting.

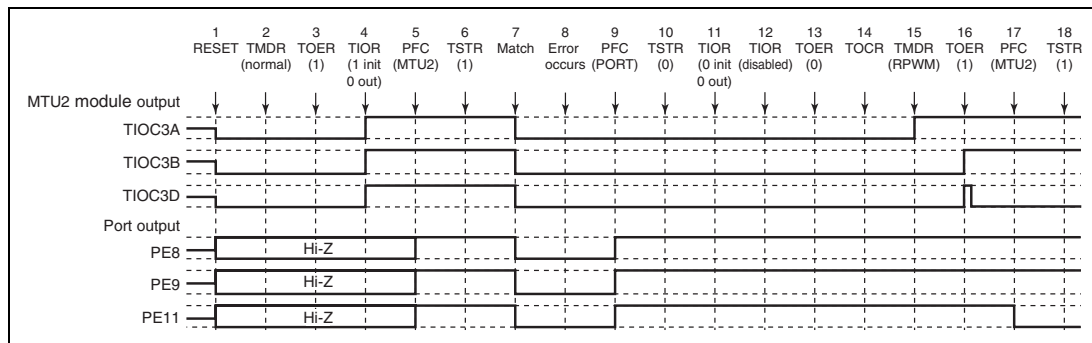

Figure 10.143 Error Occurrence in Normal Mode, Recovery in Reset-Synchronized PWM Mode

1 to 13 are the same as in figure 10.138.

14. Select the reset-synchronized PWM output level and cyclic output enabling/disabling with TOCR.
15. Set reset-synchronized PWM.
16. Enable channel 3 and 4 output with TOER.
17. Set MTU2 output with the PFC.
18. Operation is restarted by TSTR.

Operation when Error Occurs during PWM Mode 1 Operation, and Operation is Restarted in Normal Mode: Figure 10.144 shows an explanatory diagram of the case where an error occurs in PWM mode 1 and operation is restarted in normal mode after re-setting.

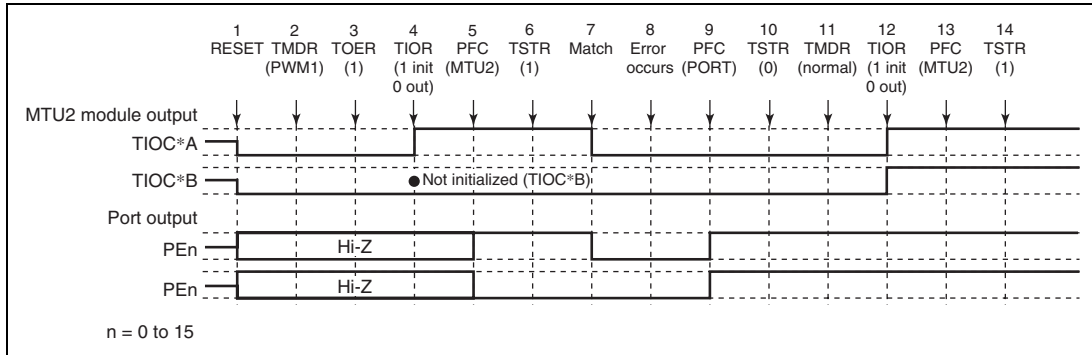

Figure 10.144 Error Occurrence in PWM Mode 1, Recovery in Normal Mode

1. After a reset, MTU2 output is low and ports are in the high-impedance state.
2. Set PWM mode 1.
3. For channels 3 and 4, enable output with TOER before initializing the pins with TIOR.
4. Initialize the pins with TIOR. (The example shows initial high output, with low output on compare-match occurrence. In PWM mode 1, the TIOC*B side is not initialized.)
5. Set MTU2 output with the PFC.
6. The count operation is started by TSTR.
7. Output goes low on compare-match occurrence.
8. An error occurs.
9. Set port output with the PFC and output the inverse of the active level.
10. The count operation is stopped by TSTR.
11. Set normal mode.
12. Initialize the pins with TIOR.
13. Set MTU2 output with the PFC.
14. Operation is restarted by TSTR.

Operation when Error Occurs during PWM Mode 1 Operation, and Operation is Restarted in PWM Mode 1: Figure 10.145 shows an explanatory diagram of the case where an error occurs in PWM mode 1 and operation is restarted in PWM mode 1 after re-setting.

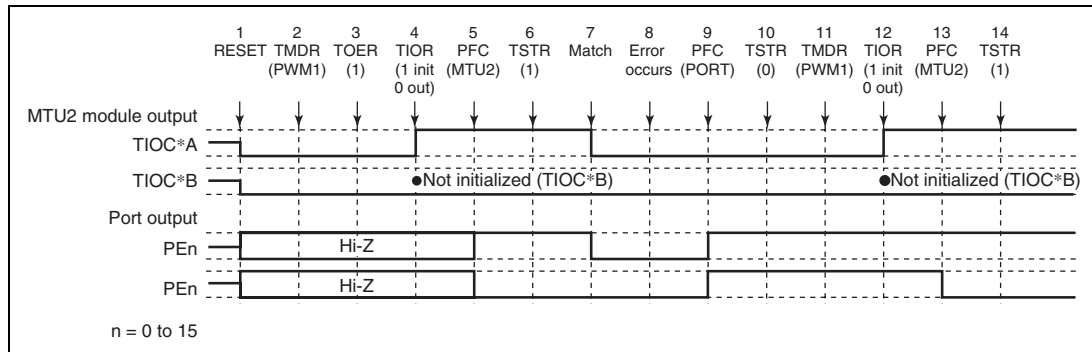

Figure 10.145 Error Occurrence in PWM Mode 1, Recovery in PWM Mode 1

1 to 10 are the same as in figure 10.144.

11. Not necessary when restarting in PWM mode 1.
12. Initialize the pins with TIOR. (In PWM mode 1, the TIOC*B side is not initialized.)
13. Set MTU2 output with the PFC.
14. Operation is restarted by TSTR.

Operation when Error Occurs during PWM Mode 1 Operation, and Operation is Restarted in PWM Mode 2: Figure 10.146 shows an explanatory diagram of the case where an error occurs in PWM mode 1 and operation is restarted in PWM mode 2 after re-setting.

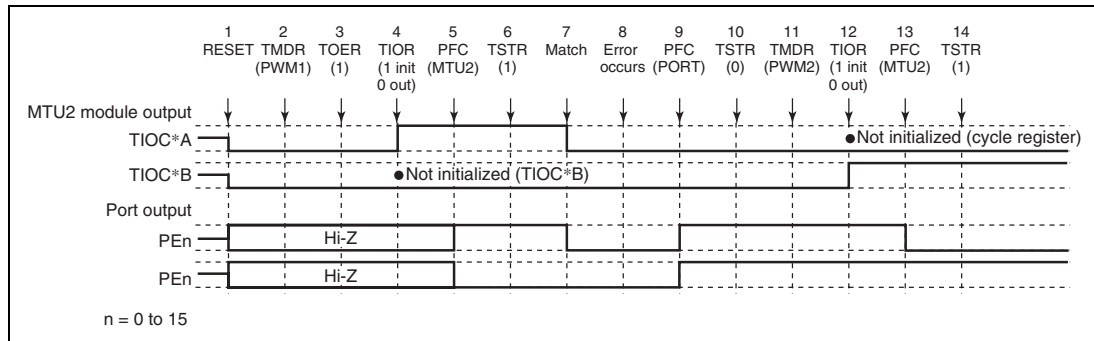

Figure 10.146 Error Occurrence in PWM Mode 1, Recovery in PWM Mode 2

1 to 10 are the same as in figure 10.144.

11. Set PWM mode 2.
12. Initialize the pins with TIOR. (In PWM mode 2, the cycle register pins are not initialized.)
13. Set MTU2 output with the PFC.
14. Operation is restarted by TSTR.

Note: PWM mode 2 can only be set for channels 0 to 2, and therefore TOER setting is not necessary.

Operation when Error Occurs during PWM Mode 1 Operation, and Operation is Restarted in Phase Counting Mode: Figure 10.147 shows an explanatory diagram of the case where an error occurs in PWM mode 1 and operation is restarted in phase counting mode after re-setting.

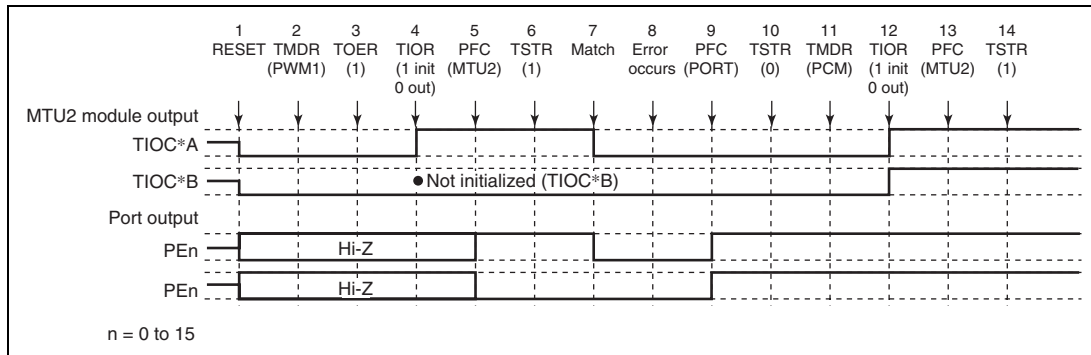

Figure 10.147 Error Occurrence in PWM Mode 1, Recovery in Phase Counting Mode

1 to 10 are the same as in figure 10.144.

11. Set phase counting mode.
12. Initialize the pins with TIOR.
13. Set MTU2 output with the PFC.
14. Operation is restarted by TSTR.

Note: Phase counting mode can only be set for channels 1 and 2, and therefore TOER setting is not necessary.

Operation when Error Occurs during PWM Mode 1 Operation, and Operation is Restarted in Complementary PWM Mode: Figure 10.148 shows an explanatory diagram of the case where an error occurs in PWM mode 1 and operation is restarted in complementary PWM mode after re-setting.

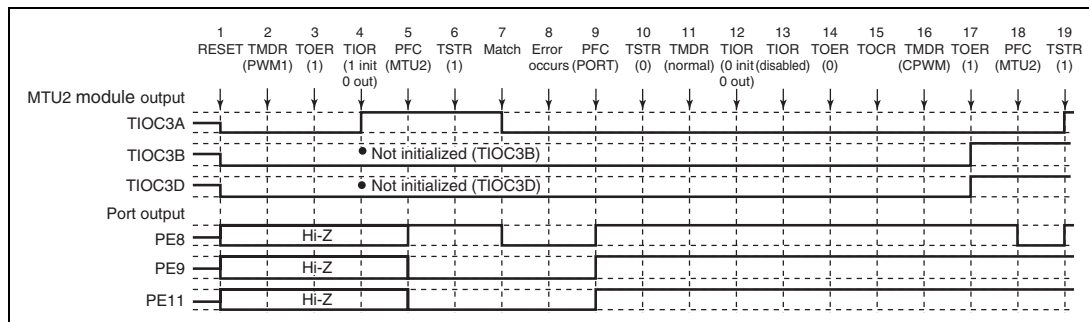

Figure 10.148 Error Occurrence in PWM Mode 1, Recovery in Complementary PWM Mode

1 to 10 are the same as in figure 10.144.

11. Set normal mode for initialization of the normal mode waveform generation section.
12. Initialize the PWM mode 1 waveform generation section with TIOR.
13. Disable operation of the PWM mode 1 waveform generation section with TIOR.
14. Disable channel 3 and 4 output with TOER.
15. Select the complementary PWM output level and cyclic output enabling/disabling with TOCR.
16. Set complementary PWM.
17. Enable channel 3 and 4 output with TOER.
18. Set MTU2 output with the PFC.
19. Operation is restarted by TSTR.

Operation when Error Occurs during PWM Mode 1 Operation, and Operation is Restarted in Reset-Synchronized PWM Mode: Figure 10.149 shows an explanatory diagram of the case where an error occurs in PWM mode 1 and operation is restarted in reset-synchronized PWM mode after re-setting.

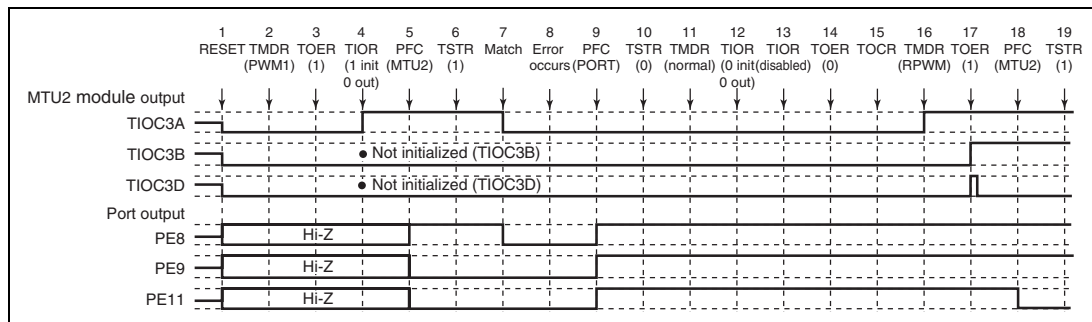

Figure 10.149 Error Occurrence in PWM Mode 1, Recovery in Reset-Synchronized PWM Mode

1 to 14 are the same as in figure 10.148.

15. Select the reset-synchronized PWM output level and cyclic output enabling/disabling with TOCR.
16. Set reset-synchronized PWM.
17. Enable channel 3 and 4 output with TOER.
18. Set MTU2 output with the PFC.
19. Operation is restarted by TSTR.

Operation when Error Occurs during PWM Mode 2 Operation, and Operation is Restarted in Normal Mode: Figure 10.150 shows an explanatory diagram of the case where an error occurs in PWM mode 2 and operation is restarted in normal mode after re-setting.

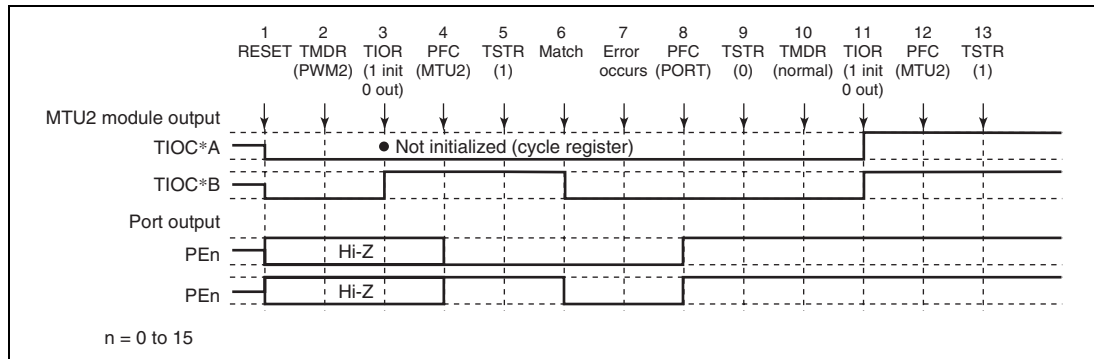

Figure 10.150 Error Occurrence in PWM Mode 2, Recovery in Normal Mode

1. After a reset, MTU2 output is low and ports are in the high-impedance state.
2. Set PWM mode 2.
3. Initialize the pins with TIOR. (The example shows initial high output, with low output on compare-match occurrence. In PWM mode 2, the cycle register pins are not initialized. In the example, TIOC *A is the cycle register.)
4. Set MTU2 output with the PFC.
5. The count operation is started by TSTR.
6. Output goes low on compare-match occurrence.
7. An error occurs.
8. Set port output with the PFC and output the inverse of the active level.
9. The count operation is stopped by TSTR.
10. Set normal mode.
11. Initialize the pins with TIOR.
12. Set MTU2 output with the PFC.
13. Operation is restarted by TSTR.

Operation when Error Occurs during PWM Mode 2 Operation, and Operation is Restarted in PWM Mode 1: Figure 10.151 shows an explanatory diagram of the case where an error occurs in PWM mode 2 and operation is restarted in PWM mode 1 after re-setting.

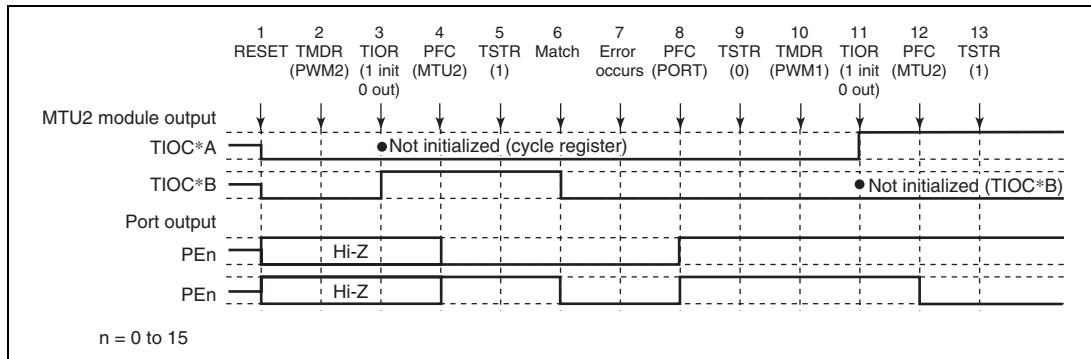

Figure 10.151 Error Occurrence in PWM Mode 2, Recovery in PWM Mode 1

1 to 9 are the same as in figure 10.150.

10. Set PWM mode 1.
11. Initialize the pins with TIOR. (In PWM mode 1, the TIOC*B side is not initialized.)
12. Set MTU2 output with the PFC.
13. Operation is restarted by TSTR.

Operation when Error Occurs during PWM Mode 2 Operation, and Operation is Restarted in PWM Mode 2: Figure 10.152 shows an explanatory diagram of the case where an error occurs in PWM mode 2 and operation is restarted in PWM mode 2 after re-setting.

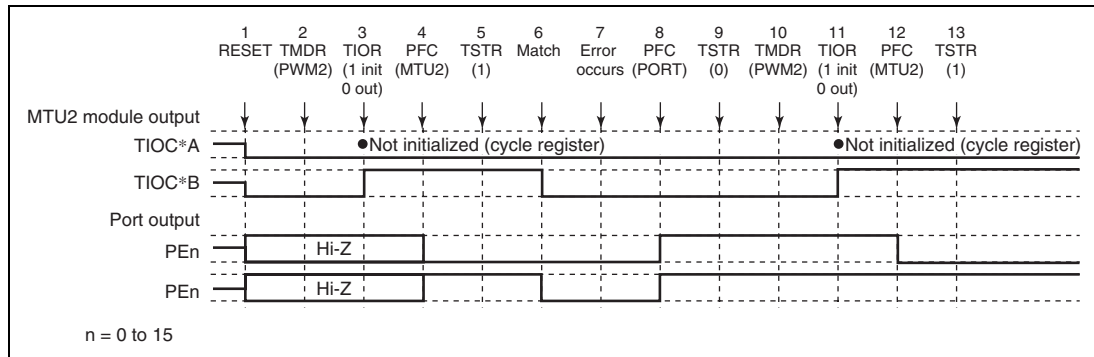

Figure 10.152 Error Occurrence in PWM Mode 2, Recovery in PWM Mode 2

1 to 9 are the same as in figure 10.150.

10. Not necessary when restarting in PWM mode 2.

11. Initialize the pins with TIOR. (In PWM mode 2, the cycle register pins are not initialized.)

12. Set MTU2 output with the PFC.

13. Operation is restarted by TSTR.

Operation when Error Occurs during PWM Mode 2 Operation, and Operation is Restarted in Phase Counting Mode: Figure 10.153 shows an explanatory diagram of the case where an error occurs in PWM mode 2 and operation is restarted in phase counting mode after re-setting.

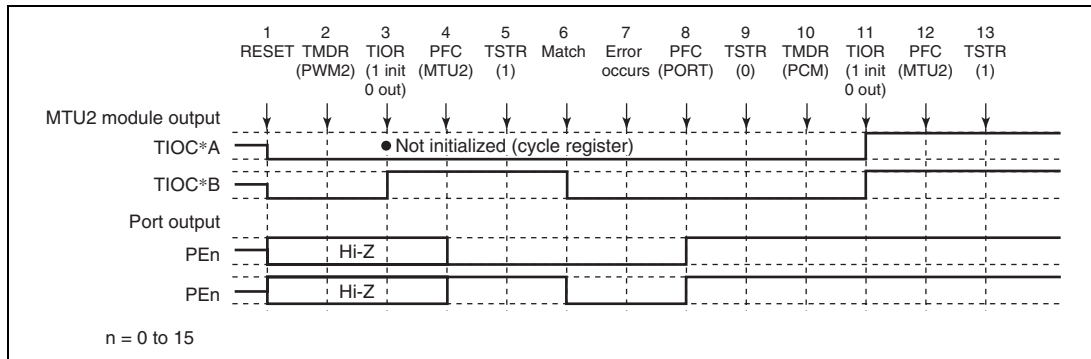

Figure 10.153 Error Occurrence in PWM Mode 2, Recovery in Phase Counting Mode

1 to 9 are the same as in figure 10.150.

10. Set phase counting mode.
11. Initialize the pins with TIOR.
12. Set MTU2 output with the PFC.
13. Operation is restarted by TSTR.

Operation when Error Occurs during Phase Counting Mode Operation, and Operation is Restarted in Normal Mode: Figure 10.154 shows an explanatory diagram of the case where an error occurs in phase counting mode and operation is restarted in normal mode after re-setting.

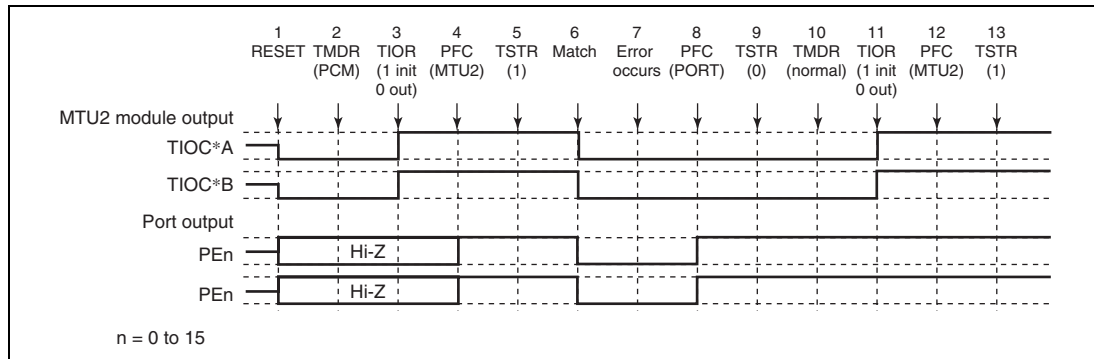

Figure 10.154 Error Occurrence in Phase Counting Mode, Recovery in Normal Mode

1. After a reset, MTU2 output is low and ports are in the high-impedance state.
2. Set phase counting mode.
3. Initialize the pins with TIOR. (The example shows initial high output, with low output on compare-match occurrence.)
4. Set MTU2 output with the PFC.
5. The count operation is started by TSTR.
6. Output goes low on compare-match occurrence.
7. An error occurs.
8. Set port output with the PFC and output the inverse of the active level.
9. The count operation is stopped by TSTR.
10. Set in normal mode.
11. Initialize the pins with TIOR.
12. Set MTU2 output with the PFC.
13. Operation is restarted by TSTR.

Operation when Error Occurs during Phase Counting Mode Operation, and Operation is Restarted in PWM Mode 1: Figure 10.155 shows an explanatory diagram of the case where an error occurs in phase counting mode and operation is restarted in PWM mode 1 after re-setting.

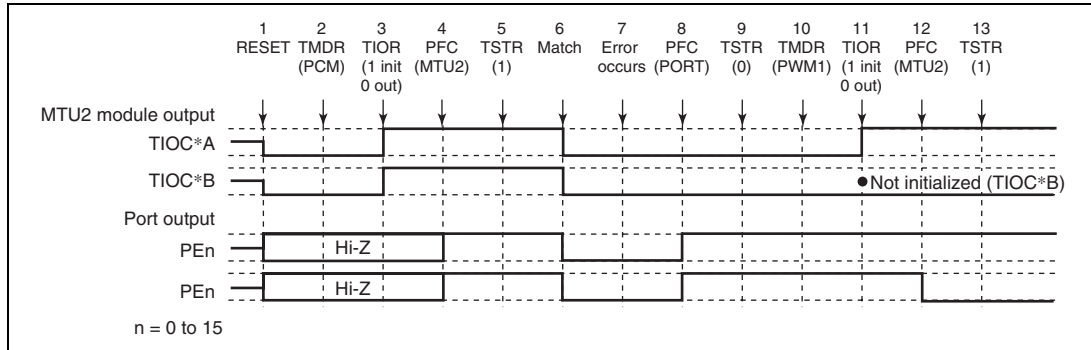

Figure 10.155 Error Occurrence in Phase Counting Mode, Recovery in PWM Mode 1

1 to 9 are the same as in figure 10.154.

10. Set PWM mode 1.
11. Initialize the pins with TIOR. (In PWM mode 1, the TIOC *B side is not initialized.)
12. Set MTU2 output with the PFC.
13. Operation is restarted by TSTR.

Operation when Error Occurs during Phase Counting Mode Operation, and Operation is Restarted in PWM Mode 2: Figure 10.156 shows an explanatory diagram of the case where an error occurs in phase counting mode and operation is restarted in PWM mode 2 after re-setting.

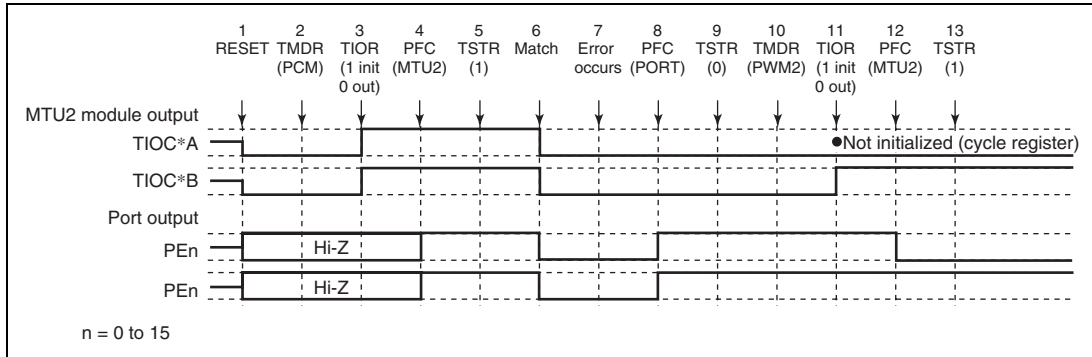

Figure 10.156 Error Occurrence in Phase Counting Mode, Recovery in PWM Mode 2

1 to 9 are the same as in figure 10.154.

10. Set PWM mode 2.

11. Initialize the pins with TIOR. (In PWM mode 2, the cycle register pins are not initialized.)

12. Set MTU2 output with the PFC.

13. Operation is restarted by TSTR.

Operation when Error Occurs during Phase Counting Mode Operation, and Operation is Restarted in Phase Counting Mode: Figure 10.157 shows an explanatory diagram of the case where an error occurs in phase counting mode and operation is restarted in phase counting mode after re-setting.

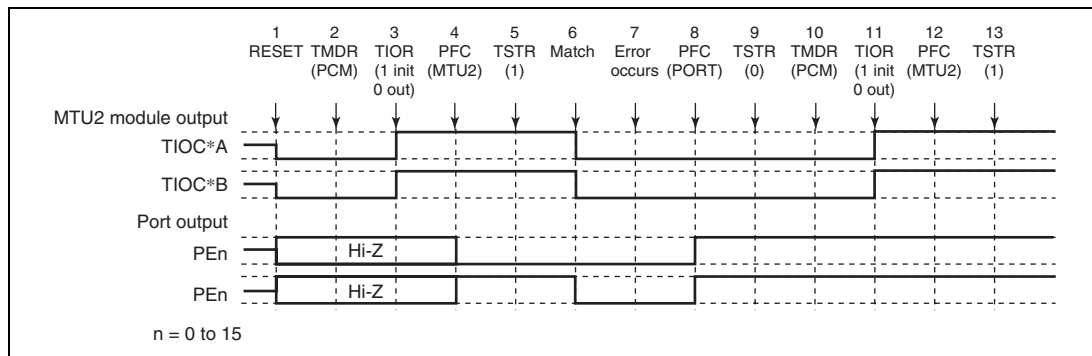

Figure 10.157 Error Occurrence in Phase Counting Mode, Recovery in Phase Counting Mode

1 to 9 are the same as in figure 10.154.

10. Not necessary when restarting in phase counting mode.

11. Initialize the pins with TIOR.

12. Set MTU2 output with the PFC.

13. Operation is restarted by TSTR.

Operation when Error Occurs during Complementary PWM Mode Operation, and Operation is Restarted in Normal Mode: Figure 10.158 shows an explanatory diagram of the case where an error occurs in complementary PWM mode and operation is restarted in normal mode after re-setting.

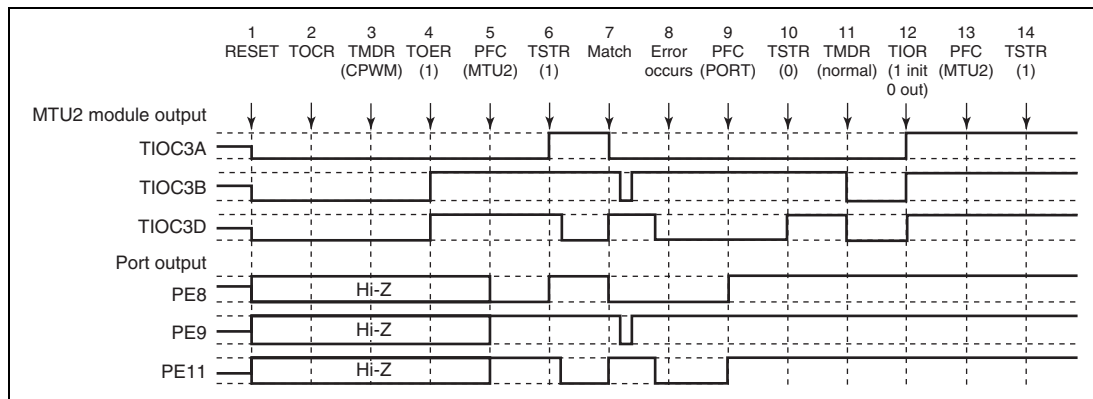

Figure 10.158 Error Occurrence in Complementary PWM Mode, Recovery in Normal Mode

1. After a reset, MTU2 output is low and ports are in the high-impedance state.
2. Select the complementary PWM output level and cyclic output enabling/disabling with TOCR.
3. Set complementary PWM.
4. Enable channel 3 and 4 output with TOER.
5. Set MTU2 output with the PFC.
6. The count operation is started by TSTR.
7. The complementary PWM waveform is output on compare-match occurrence.
8. An error occurs.
9. Set port output with the PFC and output the inverse of the active level.
10. The count operation is stopped by TSTR. (MTU2 output becomes the complementary PWM output initial value.)
11. Set normal mode. (MTU2 output goes low.)
12. Initialize the pins with TIOR.
13. Set MTU2 output with the PFC.
14. Operation is restarted by TSTR.

Operation when Error Occurs during Complementary PWM Mode Operation, and Operation is Restarted in PWM Mode 1: Figure 10.159 shows an explanatory diagram of the case where an error occurs in complementary PWM mode and operation is restarted in PWM mode 1 after re-setting.

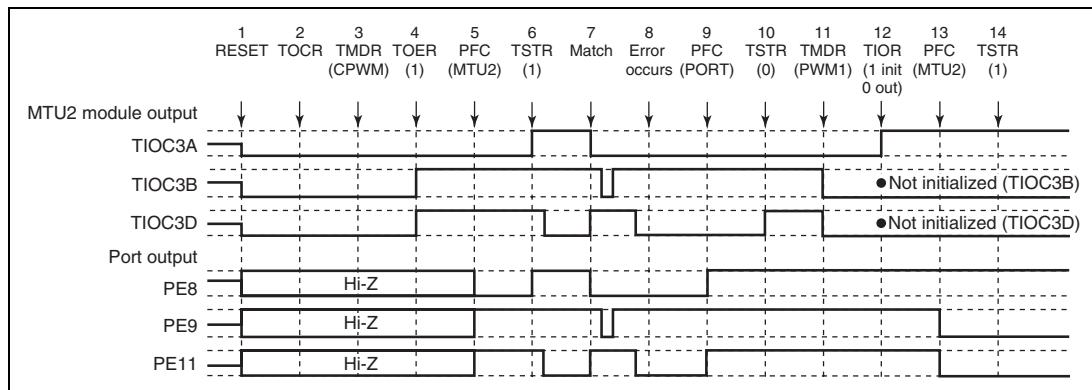

Figure 10.159 Error Occurrence in Complementary PWM Mode, Recovery in PWM Mode 1

1 to 10 are the same as in figure 10.158.

11. Set PWM mode 1. (MTU2 output goes low.)
12. Initialize the pins with TIOR. (In PWM mode 1, the TIOC *B side is not initialized.)
13. Set MTU2 output with the PFC.
14. Operation is restarted by TSTR.

Operation when Error Occurs during Complementary PWM Mode Operation, and Operation is Restarted in Complementary PWM Mode: Figure 10.160 shows an explanatory diagram of the case where an error occurs in complementary PWM mode and operation is restarted in complementary PWM mode after re-setting (when operation is restarted using the cycle and duty settings at the time the counter was stopped).

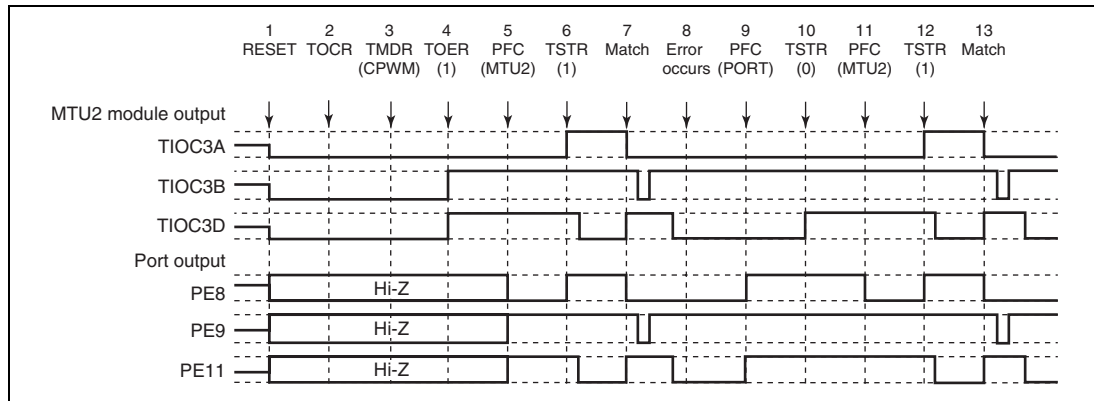

Figure 10.160 Error Occurrence in Complementary PWM Mode, Recovery in Complementary PWM Mode

1 to 10 are the same as in figure 10.158.

11. Set MTU2 output with the PFC.
12. Operation is restarted by TSTR.
13. The complementary PWM waveform is output on compare-match occurrence.

Operation when Error Occurs during Complementary PWM Mode Operation, and Operation is Restarted in Complementary PWM Mode: Figure 10.161 shows an explanatory diagram of the case where an error occurs in complementary PWM mode and operation is restarted in complementary PWM mode after re-setting (when operation is restarted using completely new cycle and duty settings).

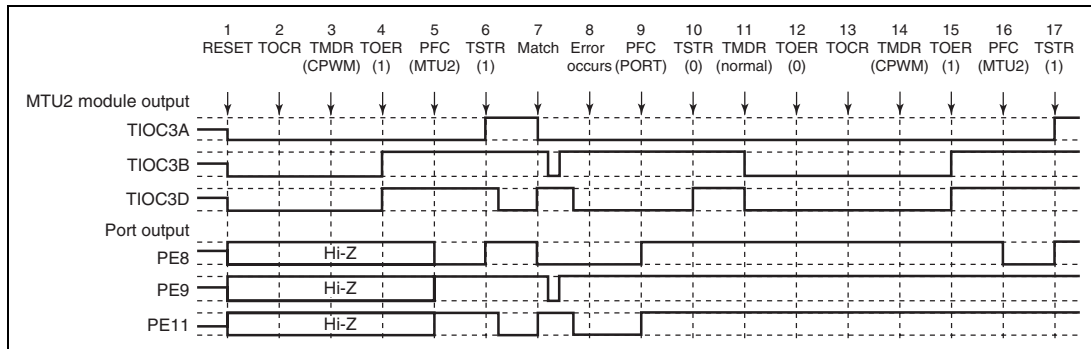

Figure 10.161 Error Occurrence in Complementary PWM Mode, Recovery in Complementary PWM Mode

1 to 10 are the same as in figure 10.158.

11. Set normal mode and make new settings. (MTU2 output goes low.)
12. Disable channel 3 and 4 output with TOER.
13. Select the complementary PWM mode output level and cyclic output enabling/disabling with TOCR.
14. Set complementary PWM.
15. Enable channel 3 and 4 output with TOER.
16. Set MTU2 output with the PFC.
17. Operation is restarted by TSTR.

Operation when Error Occurs during Complementary PWM Mode Operation, and Operation is Restarted in Reset-Synchronized PWM Mode: Figure 10.162 shows an explanatory diagram of the case where an error occurs in complementary PWM mode and operation is restarted in reset-synchronized PWM mode after re-setting.

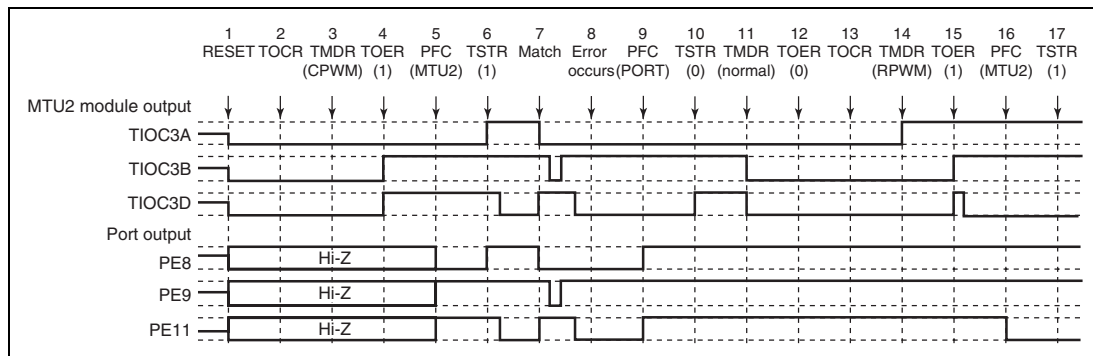

Figure 10.162 Error Occurrence in Complementary PWM Mode, Recovery in Reset-Synchronized PWM Mode

1 to 10 are the same as in figure 10.158.

11. Set normal mode. (MTU2 output goes low.)
12. Disable channel 3 and 4 output with TOER.
13. Select the reset-synchronized PWM mode output level and cyclic output enabling/disabling with TOCR.
14. Set reset-synchronized PWM.
15. Enable channel 3 and 4 output with TOER.
16. Set MTU2 output with the PFC.
17. Operation is restarted by TSTR.

Operation when Error Occurs during Reset-Synchronized PWM Mode Operation, and Operation is Restarted in Normal Mode: Figure 10.163 shows an explanatory diagram of the case where an error occurs in reset-synchronized PWM mode and operation is restarted in normal mode after re-setting.

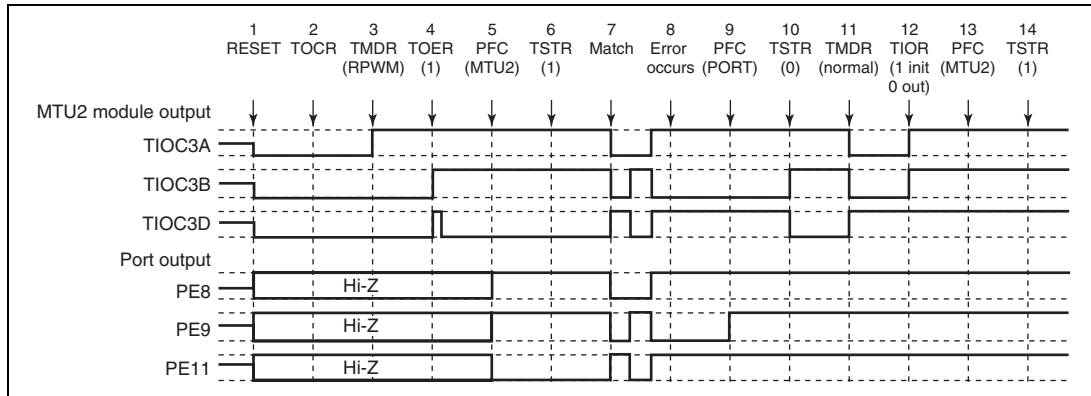

Figure 10.163 Error Occurrence in Reset-Synchronized PWM Mode, Recovery in Normal Mode

1. After a reset, MTU2 output is low and ports are in the high-impedance state.
2. Select the reset-synchronized PWM output level and cyclic output enabling/disabling with TOCR.
3. Set reset-synchronized PWM.
4. Enable channel 3 and 4 output with TOER.
5. Set MTU2 output with the PFC.
6. The count operation is started by TSTR.
7. The reset-synchronized PWM waveform is output on compare-match occurrence.
8. An error occurs.
9. Set port output with the PFC and output the inverse of the active level.
10. The count operation is stopped by TSTR. (MTU2 output becomes the reset-synchronized PWM output initial value.)
11. Set normal mode. (MTU2 positive phase output is low, and negative phase output is high.)
12. Initialize the pins with TIOR.
13. Set MTU2 output with the PFC.
14. Operation is restarted by TSTR.

Operation when Error Occurs during Reset-Synchronized PWM Mode Operation, and Operation is Restarted in PWM Mode 1: Figure 10.164 shows an explanatory diagram of the case where an error occurs in reset-synchronized PWM mode and operation is restarted in PWM mode 1 after re-setting.

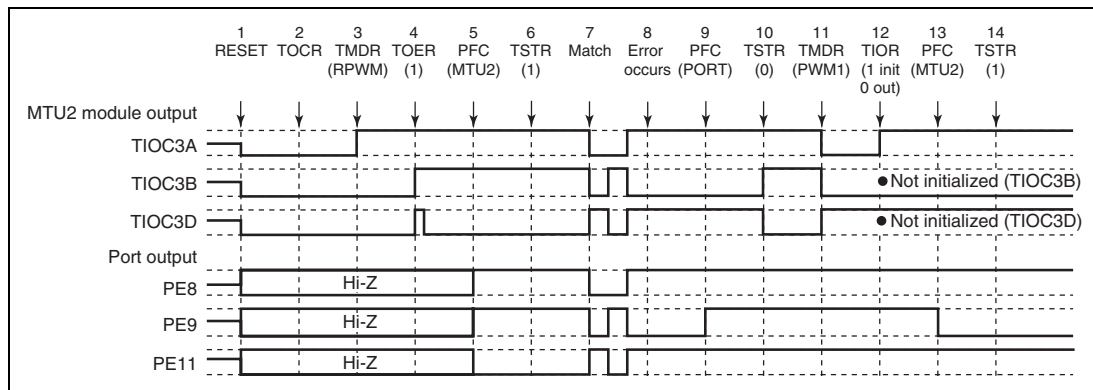

Figure 10.164 Error Occurrence in Reset-Synchronized PWM Mode, Recovery in PWM Mode 1

1 to 10 are the same as in figure 10.163.

11. Set PWM mode 1. (MTU2 positive phase output is low, and negative phase output is high.)
12. Initialize the pins with TIOR. (In PWM mode 1, the TIOC *B side is not initialized.)
13. Set MTU2 output with the PFC.
14. Operation is restarted by TSTR.

Operation when Error Occurs during Reset-Synchronized PWM Mode Operation, and Operation is Restarted in Complementary PWM Mode: Figure 10.165 shows an explanatory diagram of the case where an error occurs in reset-synchronized PWM mode and operation is restarted in complementary PWM mode after re-setting.

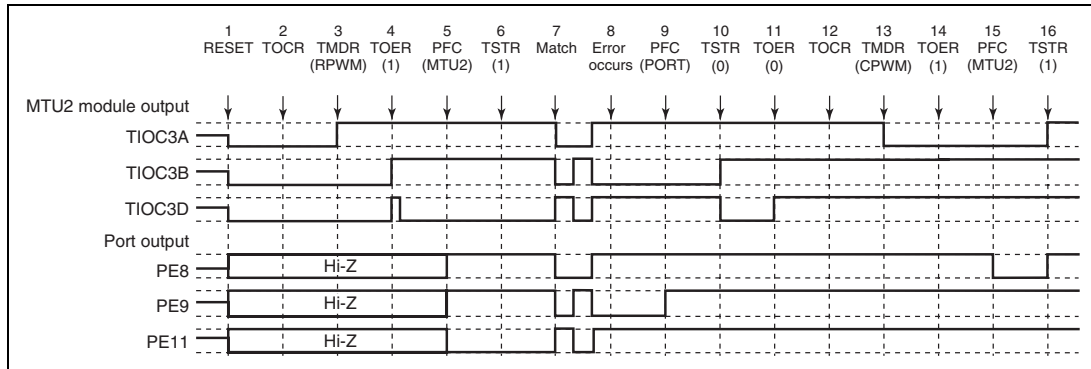

Figure 10.165 Error Occurrence in Reset-Synchronized PWM Mode, Recovery in Complementary PWM Mode

1 to 10 are the same as in figure 10.163.

11. Disable channel 3 and 4 output with TOER.
12. Select the complementary PWM output level and cyclic output enabling/disabling with TOCR.
13. Set complementary PWM. (The MTU2 cyclic output pin goes low.)
14. Enable channel 3 and 4 output with TOER.
15. Set MTU2 output with the PFC.
16. Operation is restarted by TSTR.

Operation when Error Occurs during Reset-Synchronized PWM Mode Operation, and Operation is Restarted in Reset-Synchronized PWM Mode: Figure 10.166 shows an explanatory diagram of the case where an error occurs in reset-synchronized PWM mode and operation is restarted in reset-synchronized PWM mode after re-setting.

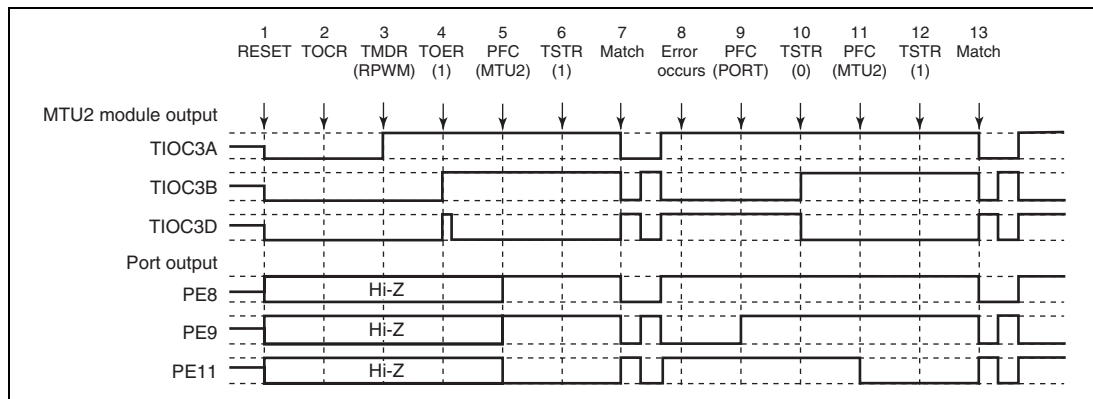

Figure 10.166 Error Occurrence in Reset-Synchronized PWM Mode, Recovery in Reset-Synchronized PWM Mode

1 to 10 are the same as in figure 10.163.

11. Set MTU2 output with the PFC.
12. Operation is restarted by TSTR.
13. The reset-synchronized PWM waveform is output on compare-match occurrence.

Section 11 Multi-Function Timer Pulse Unit 2S (MTU2S)

This LSI has an on-chip multi-function timer pulse unit 2S (MTU2S) that comprises three 16-bit timer channels. The MTU2S includes channels 3 to 5 of the MTU2. For details, refer to section 10, Multi-Function Timer Pulse Unit 2 (MTU2). To distinguish from the MTU2, "S" is added to the end of the MTU2S input/output pin and register names. For example, TIOC3A is called TIOC3AS and TGRA_3 is called TGRA_3S in this section.

The MTU2S can operate at 80 MHz max. for complementary PWM output functions or at 40 MHz max. for the other functions.

Table 11.1 MTU2S Functions

Item	Channel 3	Channel 4	Channel 5
Count clock	MI ϕ /1 MI ϕ /4 MI ϕ /16 MI ϕ /64 MI ϕ /256 MI ϕ /1024	MI ϕ /1 MI ϕ /4 MI ϕ /16 MI ϕ /64 MI ϕ /256 MI ϕ /1024	MI ϕ /1 MI ϕ /4 MI ϕ /16 MI ϕ /64
General registers	TGRA_3S TGRB_3S	TGRA_4S TGRB_4S	TGRU_5S TGRV_5S TGRW_5S
General registers/ buffer registers	TGRC_3S TGRD_3S	TGRC_4S TGRD_4S	—
I/O pins	TIOC3BS TIOC3DS	TIOC4AS TIOC4BS TIOC4CS TIOC4DS	Input pins TIC5US TIC5VS TIC5WS
Counter clear function	TGR compare match or input capture	TGR compare match or input capture	TGR compare match or input capture
Compare match output	0 output	√	—
	1 output	√	—
	Toggle output	√	—
Input capture function	√	√	√
Synchronous operation	√	√	—
PWM mode 1	—	—	—
PWM mode 2	—	—	—
Complementary PWM mode	√	√	—
Reset PWM mode	√	√	—
AC synchronous motor drive mode	—	—	—
Phase counting mode	—	—	—
Buffer operation	√	√	—

Item	Channel 3	Channel 4	Channel 5
Counter function of compensation for dead time	—	—	√
DTC activation	TGR compare match or input capture	TGR compare match or input capture and TCNT overflow or underflow	TGR compare match or input capture
A/D converter start trigger	TGRA_3S compare match or input capture	TGRA_4S compare match or input capture TCNT_4S underflow (trough) in complementary PWM mode	—
Interrupt sources	5 sources <ul style="list-style-type: none"> • Compare match or input capture 3AS • Compare match or input capture 3BS • Compare match or input capture 3CS • Compare match or input capture 3DS • Overflow 	5 sources <ul style="list-style-type: none"> • Compare match or input capture 4AS • Compare match or input capture 4BS • Compare match or input capture 4CS • Compare match or input capture 4DS • Overflow or underflow 	3 sources <ul style="list-style-type: none"> • Compare match or input capture 5US • Compare match or input capture 5VS • Compare match or input capture 5WS
A/D converter start request delaying function	—	<ul style="list-style-type: none"> • A/D converter start request at a match between TADCORA_4S and TCNT_4S • A/D converter start request at a match between TADCORB_4S and TCNT_4S 	—

Item	Channel 3	Channel 4	Channel 5
Interrupt skipping function	<ul style="list-style-type: none">• Skips TGRA_3S compare match interrupts	<ul style="list-style-type: none">• Skips TCIV_4S interrupts	—

[Legend]

√: Possible

—: Not possible

11.1 Input/Output Pins

Table 11.2 Pin Configuration

Channel	Symbol	I/O	Function
3	TIOC3BS	I/O	TGRB_3S input capture input/output compare output/PWM output pin
	TIOC3DS	I/O	TGRD_3S input capture input/output compare output/PWM output pin
4	TIOC4AS	I/O	TGRA_4S input capture input/output compare output/PWM output pin
	TIOC4BS	I/O	TGRB_4S input capture input/output compare output/PWM output pin
	TIOC4CS	I/O	TGRC_4S input capture input/output compare output/PWM output pin
	TIOC4DS	I/O	TGRD_4S input capture input/output compare output/PWM output pin
5	TIC5US	Input	TGRU_5S input capture input/external pulse input pin
	TIC5VS	Input	TGRV_5S input capture input/external pulse input pin
	TIC5WS	Input	TGRW_5S input capture input/external pulse input pin

11.2 Register Descriptions

The MTU2S has the following registers. For details on register addresses and register states during each process, refer to section 23, List of Registers. To distinguish registers in each channel, an underscore and the channel number are added as a suffix to the register name; TCR for channel 3 is expressed as TCR_3S.

Table 11.3 Register Configuration

Register Name	Abbreviation	R/W	Initial Value	Address	Access Size
Timer control register_3S	TCR_3S	R/W	H'00	H'FFFFC600	8, 16, 32
Timer control register_4S	TCR_4S	R/W	H'00	H'FFFFC601	8
Timer mode register_3S	TMDR_3S	R/W	H'00	H'FFFFC602	8, 16
Timer mode register_4S	TMDR_4S	R/W	H'00	H'FFFFC603	8
Timer I/O control register H_3S	TIORH_3S	R/W	H'00	H'FFFFC604	8, 16, 32
Timer I/O control register L_3S	TIORL_3S	R/W	H'00	H'FFFFC605	8
Timer I/O control register H_4S	TIORH_4S	R/W	H'00	H'FFFFC606	8, 16
Timer I/O control register L_4S	TIORL_4S	R/W	H'00	H'FFFFC607	8
Timer interrupt enable register_3S	TIER_3S	R/W	H'00	H'FFFFC608	8, 16
Timer interrupt enable register_4S	TIER_4S	R/W	H'00	H'FFFFC609	8
Timer output master enable register S	TOERS	R/W	H'C0	H'FFFFC60A	8
Timer gate control register S	TGCRS	R/W	H'80	H'FFFFC60D	8
Timer output control register 1S	TOCR1S	R/W	H'00	H'FFFFC60E	8, 16
Timer output control register 2S	TOCR2S	R/W	H'00	H'FFFFC60F	8
Timer counter_3S	TCNT_3S	R/W	H'0000	H'FFFFC610	16, 32
Timer counter_4S	TCNT_4S	R/W	H'0000	H'FFFFC612	16
Timer cycle data register S	TCDRS	R/W	H'FFFF	H'FFFFC614	16, 32
Timer dead time data register S	TDDRS	R/W	H'FFFF	H'FFFFC616	16
Timer general register A_3S	TGRA_3S	R/W	H'FFFF	H'FFFFC618	16, 32
Timer general register B_3S	TGRB_3S	R/W	H'FFFF	H'FFFFC61A	16
Timer general register A_4S	TGRA_4S	R/W	H'FFFF	H'FFFFC61C	16, 32
Timer general register B_4S	TGRB_4S	R/W	H'FFFF	H'FFFFC61E	16

Register Name	Abbrevia- tion	R/W	Initial Value	Address	Access Size
Timer subcounter S	TCNTSS	R	H'0000	H'FFFFC620	16, 32
Timer cycle buffer register S	TCBRS	R/W	H'FFFF	H'FFFFC622	16
Timer general register C_3S	TGRC_3S	R/W	H'FFFF	H'FFFFC624	16, 32
Timer general register D_3S	TGRD_3S	R/W	H'FFFF	H'FFFFC626	16
Timer general register C_4S	TGRC_4S	R/W	H'FFFF	H'FFFFC628	16, 32
Timer general register D_4S	TGRD_4S	R/W	H'FFFF	H'FFFFC62A	16
Timer status register_3S	TSR_3S	R/W	H'C0	H'FFFFC62C	8, 16
Timer status register_4S	TSR_4S	R/W	H'C0	H'FFFFC62D	8
Timer interrupt skipping set register S	TITCRS	R/W	H'00	H'FFFFC630	8, 16
Timer interrupt skipping counter S	TITCNTS	R	H'00	H'FFFFC631	8
Timer buffer transfer set register S	TBTERS	R/W	H'00	H'FFFFC632	8
Timer dead time enable register S	TDERS	R/W	H'01	H'FFFFC634	8
Timer output level buffer register S	TOLBRS	R/W	H'00	H'FFFFC636	8
Timer buffer operation transfer mode register_3S	TBTM_3S	R/W	H'00	H'FFFFC638	8, 16
Timer buffer operation transfer mode register_4S	TBTM_4S	R/W	H'00	H'FFFFC639	8
Timer A/D converter start request control register S	TADCRS	R/W	H'0000	H'FFFFC640	16
Timer A/D converter start request cycle set register A_4S	TADCORA_4S	R/W	H'FFFF	H'FFFFC644	16, 32
Timer A/D converter start request cycle set register B_4S	TADCORB_4S	R/W	H'FFFF	H'FFFFC646	16
Timer A/D converter start request cycle set buffer register A_4S	TADCOBRA_4S	R/W	H'FFFF	H'FFFFC648	16, 32
Timer A/D converter start request cycle set buffer register B_4S	TADCOBRB_4S	R/W	H'FFFF	H'FFFFC64A	16

Register Name	Abbrevia- tion	R/W	Initial Value	Address	Access Size
Timer synchronous clear register S	TSYCRS	R/W	H'00	H'FFFC650	8
Timer waveform control register S	TWCRS	R/W	H'00	H'FFFC660	8
Timer start register S	TSTRS	R/W	H'00	H'FFFC680	8, 16
Timer synchronous register S	TSYRS	R/W	H'00	H'FFFC681	8
Timer read/write enable register S	TRWERS	R/W	H'01	H'FFFC684	8
Timer counter U_5S	TCNTU_5S	R/W	H'0000	H'FFFC880	16, 32
Timer general register U_5S	TGRU_5S	R/W	H'FFFF	H'FFFC882	16
Timer control register U_5S	TCRU_5S	R/W	H'00	H'FFFC884	8
Timer I/O control register U_5S	TIORU_5S	R/W	H'00	H'FFFC886	8
Timer counter V_5S	TCNTV_5S	R/W	H'0000	H'FFFC890	16, 32
Timer general register V_5S	TGRV_5S	R/W	H'FFFF	H'FFFC892	16
Timer control register V_5S	TCRV_5S	R/W	H'00	H'FFFC894	8
Timer I/O control register V_5S	TIORV_5S	R/W	H'00	H'FFFC896	8
Timer counter W_5S	TCNTW_5S	R/W	H'0000	H'FFFC8A0	16, 32
Timer general register W_5S	TGRW_5S	R/W	H'FFFF	H'FFFC8A2	16
Timer control register W_5S	TCRW_5S	R/W	H'00	H'FFFC8A4	8
Timer I/O control register W_5S	TIORW_5S	R/W	H'00	H'FFFC8A6	8
Timer status register_5S	TSR_5S	R/W	H'00	H'FFFC8B0	8
Timer interrupt enable register_5S	TIER_5S	R/W	H'00	H'FFFC8B2	8
Timer start register_5S	TSTR_5S	R/W	H'00	H'FFFC8B4	8
Timer compare match clear register S	TCNTCMPCLRS	R/W	H'00	H'FFFC8B6	8

Section 12 Port Output Enable (POE)

The port output enable (POE) can be used to place the high-current pins (pins multiplexed with TIOC3B, TIOC3D, TIOC4A, TIOC4B, TIOC4C, and TIOC4D in the MTU2 and TIOC3BS, TIOC3DS, TIOC4AS, TIOC4BS, TIOC4CS, and TIOC4DS in the MTU2S) and the pins for channel 0 of the MTU2 (pins multiplexed with TIOC0A, TIOC0B, TIOC0C, and TIOC0D) in high-impedance state, depending on the change on $\overline{\text{POE0}}$ to $\overline{\text{POE8}}$ input pins and the output status of the high-current pins, or by modifying register settings. It can also simultaneously generate interrupt requests.

12.1 Features

- Each of the $\overline{\text{POE0}}$ to $\overline{\text{POE8}}$ input pins can be set for falling edge, $P\phi/8 \times 16$, $P\phi/16 \times 16$, or $P\phi/128 \times 16$ low-level sampling.
- High-current pins and the pins for channel 0 of the MTU2 can be placed in high-impedance state by $\overline{\text{POE0}}$ to $\overline{\text{POE8}}$ pin falling-edge or low-level sampling.
- High-current pins can be placed in high-impedance state when the high-current pin output levels are compared and simultaneous active-level output continues for one cycle or more.
- High-current pins and the pins for channel 0 of the MTU2 can be placed in high-impedance state by modifying the POE register settings.
- Interrupts can be generated by input-level sampling or output-level comparison results.

The POE has input level detection circuits, output level comparison circuits, and a high-impedance request/interrupt request generating circuit as shown in figure 12.1.

In addition to control by the POE, high-current pins can be placed in high-impedance state when the oscillator stops or in software standby state. For details, refer to appendix A, Pin States.

Figure 12.1 shows a block diagram of the POE.

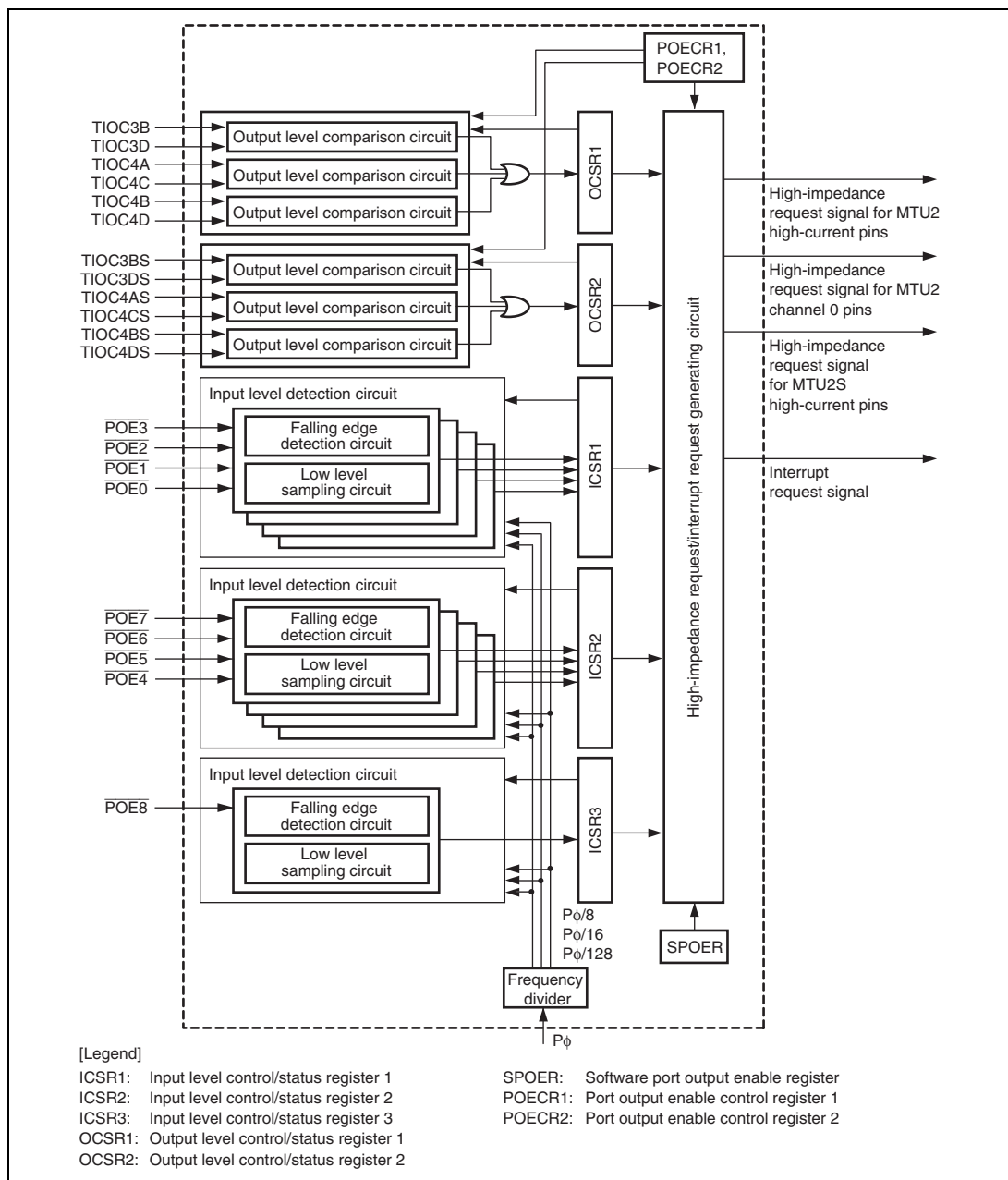

Figure 12.1 Block Diagram of POE

12.2 Input/Output Pins

Table 12.1 Pin Configuration

Name	Symbol	I/O	Description
Port output enable input pins 0 to 3	$\overline{\text{POE0}}$ to $\overline{\text{POE3}}$	Input	Input request signals to place high-current pins for MTU2 in high-impedance state*
Port output enable input pins 4 to 7	$\overline{\text{POE4}}$ to $\overline{\text{POE7}}$	Input	Input request signals to place high-current pins for MTU2S in high-impedance state*
Port output enable input pin 8	$\overline{\text{POE8}}$	Input	Inputs a request signal to place pins for channel 0 in MTU2 in high-impedance state*

Note: * When the selected functions of pins PB16/ $\overline{\text{POE3}}$, PB17/ $\overline{\text{POE7}}$, and PB18/ $\overline{\text{POE8}}$ are for the POE in the PFC, the pins are pulled up inside the LSI if nothing is input to them.

Table 12.2 shows output-level comparisons with pin combinations.

Table 12.2 Pin Combinations

Pin Combination	I/O	Description
PE9/TIOC3B and PE11/TIOC3D PE12/TIOC4A and PE14/TIOC4C PE13/TIOC4B and PE15/TIOC4D	Output	<p>The high-current pins for the MTU2 are placed in high-impedance state when the pins simultaneously output an active level (low level when the output level select P (OLSP) bit of the timer output control register (TOCR) in the MTU2 is 0 or high level when the bit is 1) for one or more cycles of the peripheral clock (Pϕ).</p> <p>This active level comparison is done when the MTU2 output function or general output function is selected in the pin function controller. If another function is selected, the output level is not checked.</p> <p>Pin combinations for output comparison and high-impedance control can be selected by POE registers.</p>
PE16/TIOC3BS and PE17/TIOC3DS PE18/TIOC4AS and PE20/TIOC4CS PE19/TIOC4BS and PE21/TIOC4DS	Output	<p>The high-current pins for the MTU2S are placed in high-impedance state when the pins simultaneously output an active level (low level when the output level select P (OLSP) bit of the timer output control register (TOCR) in the MTU2S is 0 or high level when the bit is 1) for one or more cycles of the peripheral clock (Pϕ).</p> <p>This active level comparison is done when the MTU2S output function or general output function is selected in the pin function controller. If another function is selected, the output level is not checked.</p> <p>Pin combinations for output comparison and high-impedance control can be selected by POE registers.</p>

12.3 Register Descriptions

The POE has the following registers. For details on register addresses and register states during each processing, refer to section 23, List of Registers.

Table 12.3 Register Configuration

Register Name	Abbreviation	R/W	Initial Value	Address	Access Size
Input level control/status register 1	ICSR1	R/W	H'0000	H'FFFFD000	8, 16, 32
Output level control/status register 1	OCSR1	R/W	H'0000	H'FFFFD002	8, 16
Input level control/status register 2	ICSR2	R/W	H'0000	H'FFFFD004	8, 16, 32
Output level control/status register 2	OCSR2	R/W	H'0000	H'FFFFD006	8, 16
Input level control/status register 3	ICSR3	R/W	H'0000	H'FFFFD008	8, 16
Software port output enable register	SPOER	R/W	H'00	H'FFFFD00A	8
Port output enable control register 1	POECR1	R/W	H'00	H'FFFFD00B	8
Port output enable control register 2	POECR2	R/W	H'7700	H'FFFFD00C	8, 16

12.3.1 Input Level Control/Status Register 1 (ICSR1)

ICSR1 is a 16-bit readable/writable register that selects the $\overline{\text{POE0}}$ to $\overline{\text{POE3}}$ pin input modes, controls the enable/disable of interrupts, and indicates status.

Bit:	15	14	13	12	11	10	9	8	7	6	5	4	3	2	1	0
	POE3F	POE2F	POE1F	POE0F	-	-	-	PIE1	POE3M[1:0]	POE2M[1:0]	POE1M[1:0]	POE0M[1:0]				
Initial value:	0	0	0	0	0	0	0	0	0	0	0	0	0	0	0	0
	R/W	R/(W)*1	R/(W)*1	R/(W)*1	R/(W)*1	R	R	R	R/W	R/W*2	R/W*2	R/W*2	R/W*2	R/W*2	R/W*2	R/W*2

- Notes: 1. Writing 0 to this bit after reading it as 1 clears the flag and is the only allowed way.
 2. Can be modified only once after a power-on reset.

Bit	Bit Name	Initial value	R/W	Description
15	POE3F	0	R/(W)*1	<p>POE3 Flag</p> <p>This flag indicates that a high impedance request has been input to the $\overline{\text{POE3}}$ pin.</p> <p>[Clearing conditions]</p> <ul style="list-style-type: none"> By writing 0 to POE3F after reading POE3F = 1 (when the falling edge is selected by bits 7 and 6 in ICSR1) By writing 0 to POE3F after reading POE3F = 1 after a high level input to $\overline{\text{POE3}}$ is sampled at $P\phi/8$, $P\phi/16$, or $P\phi/128$ clock (when low-level sampling is selected by bits 7 and 6 in ICSR1) <p>[Setting condition]</p> <ul style="list-style-type: none"> When the input set by ICSR1 bits 7 and 6 occurs at the $\overline{\text{POE3}}$ pin

Bit	Bit Name	Initial value	R/W	Description
14	POE2F	0	R/(W)* ¹	<p>POE2 Flag</p> <p>This flag indicates that a high impedance request has been input to the $\overline{\text{POE2}}$ pin.</p> <p>[Clearing conditions]</p> <ul style="list-style-type: none"> By writing 0 to POE2F after reading POE2F = 1 (when the falling edge is selected by bits 5 and 4 in ICSR1) By writing 0 to POE2F after reading POE2F = 1 after a high level input to POE2 is sampled at $P\phi/8$, $P\phi/16$, or $P\phi/128$ clock (when low-level sampling is selected by bits 5 and 4 in ICSR1) <p>[Setting condition]</p> <ul style="list-style-type: none"> When the input set by ICSR1 bits 5 and 4 occurs at the $\overline{\text{POE2}}$ pin
13	POE1F	0	R/(W)* ¹	<p>POE1 Flag</p> <p>This flag indicates that a high impedance request has been input to the $\overline{\text{POE1}}$ pin.</p> <p>[Clearing conditions]</p> <ul style="list-style-type: none"> By writing 0 to POE1F after reading POE1F = 1 (when the falling edge is selected by bits 3 and 2 in ICSR1) By writing 0 to POE1F after reading POE1F = 1 after a high level input to POE1 is sampled at $P\phi/8$, $P\phi/16$, or $P\phi/128$ clock (when low-level sampling is selected by bits 3 and 2 in ICSR1) <p>[Setting condition]</p> <ul style="list-style-type: none"> When the input set by ICSR1 bits 3 and 2 occurs at the $\overline{\text{POE1}}$ pin

Bit	Bit Name	Initial value	R/W	Description
12	POE0F	0	R/(W)* ¹	<p>POE0 Flag</p> <p>This flag indicates that a high impedance request has been input to the $\overline{\text{POE0}}$ pin.</p> <p>[Clearing conditions]</p> <ul style="list-style-type: none"> By writing 0 to POE0F after reading POE0F = 1 (when the falling edge is selected by bits 1 and 0 in ICSR1) By writing 0 to POE0F after reading POE0F = 1 after a high level input to POE0 is sampled at $P\phi/8$, $P\phi/16$, or $P\phi/128$ clock (when low-level sampling is selected by bits 1 and 0 in ICSR1) <p>[Setting condition]</p> <ul style="list-style-type: none"> When the input set by ICSR1 bits 1 and 0 occurs at the $\overline{\text{POE0}}$ pin
11 to 9	—	All 0	R	<p>Reserved</p> <p>These bits are always read as 0. The write value should always be 0.</p>
8	PIE1	0	R/W	<p>Port Interrupt Enable 1</p> <p>This bit enables/disables interrupt requests when any one of the POE0F to POE3F bits of the ICSR1 is set to 1.</p> <p>0: Interrupt requests disabled 1: Interrupt requests enabled</p>
7, 6	POE3M[1:0]	00	R/W* ²	<p>POE3 mode 1, 0</p> <p>These bits select the input mode of the $\overline{\text{POE3}}$ pin.</p> <p>00: Accept request on falling edge of POE3 input 01: Accept request when POE3 input has been sampled for 16 $P\phi/8$ clock pulses and all are low level. 10: Accept request when POE3 input has been sampled for 16 $P\phi/16$ clock pulses and all are low level. 11: Accept request when POE3 input has been sampled for 16 $P\phi/128$ clock pulses and all are low level.</p>

Bit	Bit Name	Initial value	R/W	Description
5, 4	POE2M[1:0]	00	R/W* ²	<p>POE2 mode 1, 0</p> <p>These bits select the input mode of the $\overline{\text{POE2}}$ pin.</p> <p>00: Accept request on falling edge of POE2 input</p> <p>01: Accept request when POE2 input has been sampled for 16 Pϕ/8 clock pulses and all are low level.</p> <p>10: Accept request when POE2 input has been sampled for 16 Pϕ/16 clock pulses and all are low level.</p> <p>11: Accept request when POE2 input has been sampled for 16 Pϕ/128 clock pulses and all are low level.</p>
3, 2	POE1M[1:0]	00	R/W* ²	<p>POE1 mode 1, 0</p> <p>These bits select the input mode of the $\overline{\text{POE1}}$ pin.</p> <p>00: Accept request on falling edge of POE1 input</p> <p>01: Accept request when POE1 input has been sampled for 16 Pϕ/8 clock pulses and all are low level.</p> <p>10: Accept request when POE1 input has been sampled for 16 Pϕ/16 clock pulses and all are low level.</p> <p>11: Accept request when POE1 input has been sampled for 16 Pϕ/128 clock pulses and all are low level.</p>
1, 0	POE0M[1:0]	00	R/W* ²	<p>POE0 mode 1, 0</p> <p>These bits select the input mode of the $\overline{\text{POE0}}$ pin.</p> <p>00: Accept request on falling edge of POE0 input</p> <p>01: Accept request when POE0 input has been sampled for 16 Pϕ/8 clock pulses and all are low level.</p> <p>10: Accept request when POE0 input has been sampled for 16 Pϕ/16 clock pulses and all are low level.</p> <p>11: Accept request when POE0 input has been sampled for 16 Pϕ/128 clock pulses and all are low level.</p>

Notes: 1. Writing 0 to this bit after reading it as 1 clears the flag and is the only allowed way.
 2. Can be modified only once after a power-on reset.

12.3.2 Output Level Control/Status Register 1 (OCSR1)

OCSR1 is a 16-bit readable/writable register that controls the enable/disable of both output level comparison and interrupts, and indicates status.

Bit:	15	14	13	12	11	10	9	8	7	6	5	4	3	2	1	0
	OSF1	-	-	-	-	-	OCE1	OIE1	-	-	-	-	-	-	-	-
Initial value:	0	0	0	0	0	0	0	0	0	0	0	0	0	0	0	0
R/W:R/(W)* ¹	R	R	R	R	R	R	R/W* ²	R/W	R	R	R	R	R	R	R	R

- Notes: 1. Writing 0 to this bit after reading it as 1 clears the flag and is the only allowed way.
 2. Can be modified only once after a power-on reset.

Bit	Bit Name	Initial value	R/W	Description
15	OSF1	0	R/(W)* ¹	<p>Output Short Flag 1</p> <p>This flag indicates that any one of the three pairs of MTU2 2-phase outputs to be compared has simultaneously become an active level.</p> <p>[Clearing condition]</p> <ul style="list-style-type: none"> By writing 0 to OSF1 after reading OSF1 = 1 <p>[Setting condition]</p> <ul style="list-style-type: none"> When any one of the three pairs of 2-phase outputs has simultaneously become an active level
14 to 10	—	All 0	R	<p>Reserved</p> <p>These bits are always read as 0. The write value should always be 0.</p>
9	OCE1	0	R/W* ²	<p>Output Short High-Impedance Enable 1</p> <p>This bit specifies whether to place the pins in high-impedance state when the OSF1 bit in OCSR1 is set to 1.</p> <p>0: Does not place the pins in high-impedance state 1: Places the pins in high-impedance state</p>
8	OIE1	0	R/W	<p>Output Short Interrupt Enable 1</p> <p>This bit enables or disables interrupt requests when the OSF1 bit in OCSR is set to 1.</p> <p>0: Interrupt requests disabled 1: Interrupt requests enabled</p>

Bit	Bit Name	Initial value	R/W	Description
7 to 0	—	All 0	R	Reserved These bits are always read as 0. The write value should always be 0.

- Notes: 1. Writing 0 to this bit after reading it as 1 clears the flag and is the only allowed way.
2. Can be modified only once after a power-on reset.

12.3.3 Input Level Control/Status Register 2 (ICSR2)

ICSR2 is a 16-bit readable/writable register that selects the $\overline{\text{POE4}}$ to $\overline{\text{POE7}}$ pin input modes, controls the enable/disable of interrupts, and indicates status.

Bit:	15	14	13	12	11	10	9	8	7	6	5	4	3	2	1	0
	POE7F	POE6F	POE5F	POE4F	-	-	-	PIE2	POE7M[1:0]	POE6M[1:0]	POE5M[1:0]	POE4M[1:0]				
Initial value:	0	0	0	0	0	0	0	0	0	0	0	0	0	0	0	0
	R/W:R/(W)*1	R/(W)*1	R/(W)*1	R/(W)*1	R	R	R	R/W	R/W*2	R/W*2	R/W*2	R/W*2	R/W*2	R/W*2	R/W*2	R/W*2

- Notes: 1. Writing 0 to this bit after reading it as 1 clears the flag and is the only allowed way.
2. Can be modified only once after a power-on reset.

Bit	Bit Name	Initial value	R/W	Description
15	POE7F	0	R/(W)*1	POE7 Flag This flag indicates that a high impedance request has been input to the $\overline{\text{POE7}}$ pin. [Clearing conditions] <ul style="list-style-type: none"> By writing 0 to POE7F after reading POE7F = 1 (when the falling edge is selected by bits 7 and 6 in ICSR2) By writing 0 to POE7F after reading POE7F = 1 after a high level input to POE7 is sampled at $P\phi/8$, $P\phi/16$, or $P\phi/128$ clock (when low-level sampling is selected by bits 7 and 6 in ICSR2) [Setting condition] <ul style="list-style-type: none"> When the input condition set by bits 7 and 6 in ICSR2 occurs at the $\overline{\text{POE7}}$ pin

Bit	Bit Name	Initial value	R/W	Description
14	POE6F	0	R/(W)* ¹	<p>POE6 Flag</p> <p>This flag indicates that a high impedance request has been input to the $\overline{\text{POE6}}$ pin.</p> <p>[Clearing conditions]</p> <ul style="list-style-type: none"> By writing 0 to POE6F after reading POE6F = 1 (when the falling edge is selected by bits 5 and 4 in ICSR2) By writing 0 to POE6F after reading POE6F = 1 after a high level input to POE6 is sampled at $P\phi/8$, $P\phi/16$, or $P\phi/128$ clock (when low-level sampling is selected by bits 5 and 4 in ICSR2) <p>[Setting condition]</p> <ul style="list-style-type: none"> When the input condition set by bits 5 and 4 in ICSR2 occurs at the $\overline{\text{POE6}}$ pin
13	POE5F	0	R/(W)* ¹	<p>POE5 Flag</p> <p>This flag indicates that a high impedance request has been input to the POE5 pin.</p> <p>[Clearing conditions]</p> <ul style="list-style-type: none"> By writing 0 to POE5F after reading POE5F = 1 (when the falling edge is selected by bits 3 and 2 in ICSR2) By writing 0 to POE5F after reading POE5F = 1 after a high level input to POE5 is sampled at $P\phi/8$, $P\phi/16$, or $P\phi/128$ clock (when low-level sampling is selected by bits 3 and 2 in ICSR2) <p>[Setting condition]</p> <ul style="list-style-type: none"> When the input condition set by bits 3 and 2 in ICSR2 occurs at the $\overline{\text{POE5}}$ pin

Bit	Bit Name	Initial value	R/W	Description
12	POE4F	0	R/(W)* ¹	<p>POE4 Flag</p> <p>This flag indicates that a high impedance request has been input to the $\overline{\text{POE4}}$ pin.</p> <p>[Clearing conditions]</p> <ul style="list-style-type: none"> By writing 0 to POE4F after reading POE4F = 1 (when the falling edge is selected by bits 1 and 0 in ICSR2) By writing 0 to POE4F after reading POE4F = 1 after a high level input to POE4 is sampled at $P\phi/8$, $P\phi/16$, or $P\phi/128$ clock (when low-level sampling is selected by bits 1 and 0 in ICSR2) <p>[Setting condition]</p> <ul style="list-style-type: none"> When the input condition set by bits 1 and 0 in ICSR2 occurs at the $\overline{\text{POE4}}$ pin
11 to 9	—	All 0	R	<p>Reserved</p> <p>These bits are always read as 0. The write value should always be 0.</p>
8	PIE2	0	R/W	<p>Port Interrupt Enable 2</p> <p>This bit enables/disables interrupt requests when any one of the POE4F to POE7F bits of the ICSR2 is set to 1.</p> <p>0: Interrupt requests disabled 1: Interrupt requests enabled</p>
7, 6	POE7M[1:0]	00	R/W* ²	<p>POE7 mode 1 and 0</p> <p>These bits select the input mode of the $\overline{\text{POE7}}$ pin.</p> <p>00: Accept request on falling edge of POE7 input 01: Accept request when POE7 input has been sampled for 16 $P\phi/8$ clock pulses and all are at a low level. 10: Accept request when POE7 input has been sampled for 16 $P\phi/16$ clock pulses and all are at a low level. 11: Accept request when POE7 input has been sampled for 16 $P\phi/128$ clock pulses and all are at a low level.</p>

Bit	Bit Name	Initial value	R/W	Description
5, 4	POE6M[1:0]	00	R/W* ²	<p>POE6 mode 1 and 0</p> <p>These bits select the input mode of the $\overline{\text{POE6}}$ pin.</p> <p>00: Accept request on falling edge of POE6 input</p> <p>01: Accept request when POE6 input has been sampled for 16 Pϕ/8 clock pulses and all are at a low level.</p> <p>10: Accept request when POE6 input has been sampled for 16 Pϕ/16 clock pulses and all are at a low level.</p> <p>11: Accept request when POE6 input has been sampled for 16 Pϕ/128 clock pulses and all are at a low level.</p>
3, 2	POE5M[1:0]	00	R/W* ²	<p>POE5 mode 1 and 0</p> <p>These bits select the input mode of the $\overline{\text{POE5}}$ pin.</p> <p>00: Accept request on falling edge of POE5 input</p> <p>01: Accept request when POE5 input has been sampled for 16 Pϕ/8 clock pulses and all are at a low level.</p> <p>10: Accept request when POE5 input has been sampled for 16 Pϕ/16 clock pulses and all are at a low level.</p> <p>11: Accept request when POE5 input has been sampled for 16 Pϕ/128 clock pulses and all are at a low level.</p>
1, 0	POE4M[1:0]	00	R/W* ²	<p>POE4 mode 1 and 0</p> <p>These bits select the input mode of the $\overline{\text{POE4}}$ pin.</p> <p>00: Accept request on falling edge of POE4 input</p> <p>01: Accept request when POE4 input has been sampled for 16 Pϕ/8 clock pulses and all are at a low level.</p> <p>10: Accept request when POE4 input has been sampled for 16 Pϕ/16 clock pulses and all are at a low level.</p> <p>11: Accept request when POE4 input has been sampled for 16 Pϕ/128 clock pulses and all are at a low level.</p>

Notes: 1. Writing 0 to this bit after reading it as 1 clears the flag and is the only allowed way.
 2. Can be modified only once after a power-on reset.

12.3.4 Output Level Control/Status Register 2 (OCSR2)

OCSR2 is a 16-bit readable/writable register that controls the enable/disable of both output level comparison and interrupts, and indicates status.

Bit:	15	14	13	12	11	10	9	8	7	6	5	4	3	2	1	0
	OSF2	-	-	-	-	-	OCE2	OIE2	-	-	-	-	-	-	-	-
Initial value:	0	0	0	0	0	0	0	0	0	0	0	0	0	0	0	0
R/W:R/(W)*1	R	R	R	R	R	R	R/W*2	R/W	R	R	R	R	R	R	R	R

- Notes: 1. Writing 0 to this bit after reading it as 1 clears the flag and is the only allowed way.
 2. Can be modified only once after a power-on reset.

Bit	Bit Name	Initial value	R/W	Description
15	OSF2	0	R/(W)*1	Output Short Flag 2 This flag indicates that any one of the three pairs of MTU2S 2-phase outputs to be compared has simultaneously become an active level. [Clearing condition] <ul style="list-style-type: none"> By writing 0 to OSF2 after reading OSF2 = 1 [Setting condition] <ul style="list-style-type: none"> When any one of the three pairs of 2-phase outputs has simultaneously become an active level
14 to 10	—	All 0	R	Reserved These bits are always read as 0. The write value should always be 0.
9	OCE2	0	R/W*2	Output Short High-Impedance Enable 2 This bit specifies whether to place the pins in high-impedance state when the OSF2 bit in OCSR2 is set to 1. 0: Does not place the pins in high-impedance state 1: Places the pins in high-impedance state
8	OIE2	0	R/W	Output Short Interrupt Enable 2 This bit enables or disables interrupt requests when the OSF2 bit in OCSR2 is set to 1. 0: Interrupt requests disabled 1: Interrupt requests enabled

Bit	Bit Name	Initial value	R/W	Description
7 to 0	—	All 0	R	Reserved These bits are always read as 0. The write value should always be 0.

Notes: 1. Writing 0 to this bit after reading it as 1 clears the flag and is the only allowed way.
2. Can be modified only once after a power-on reset.

12.3.5 Input Level Control/Status Register 3 (ICSR3)

ICSR3 is a 16-bit readable/writable register that selects the $\overline{\text{POE8}}$ pin input mode, controls the enable/disable of interrupts, and indicates status.

Bit:	15	14	13	12	11	10	9	8	7	6	5	4	3	2	1	0
	-	-	-	POE8F	-	-	POE8E	PIE3	-	-	-	-	-	-	-	POE8M[1:0]
Initial value:	0	0	0	0	0	0	0	0	0	0	0	0	0	0	0	0
R/W:	R	R	R	R/(W)*1	R	R	R/W*2	R/W	R	R	R	R	R	R	R/W*2	R/W*2

Notes: 1. Writing 0 to this bit after reading it as 1 clears the flag and is the only allowed way.
2. Can be modified only once after a power-on reset.

Bit	Bit Name	Initial value	R/W	Description
15 to 13	—	All 0	R	Reserved These bits are always read as 0. The write value should always be 0.
12	POE8F	0	R/(W)*1	POE8 Flag This flag indicates that a high impedance request has been input to the $\overline{\text{POE8}}$ pin. [Clearing conditions] <ul style="list-style-type: none"> By writing 0 to POE8F after reading POE8F = 1 (when the falling edge is selected by bits 1 and 0 in ICSR3) By writing 0 to POE8F after reading POE8F = 1 after a high level input to POE8 is sampled at $P\phi/8$, $P\phi/16$, or $P\phi/128$ clock (when low-level sampling is selected by bits 1 and 0 in ICSR3) [Setting condition] <ul style="list-style-type: none"> When the input condition set by bits 1 and 0 in ICSR3 occurs at the $\overline{\text{POE8}}$ pin

Bit	Bit Name	Initial value	R/W	Description
11, 10	—	All 0	R	Reserved These bits are always read as 0. The write value should always be 0.
9	POE8E	0	R/W* ²	POE8 High-Impedance Enable This bit specifies whether to place the pins in high-impedance state when the POE8F bit in ICSR3 is set to 1. 0: Does not place the pins in high-impedance state 1: Places the pins in high-impedance state
8	PIE3	0	R/W	Port Interrupt Enable 3 This bit enables or disables interrupt requests when the POE8 bit in ICSR3 is set to 1. 0: Interrupt requests disabled 1: Interrupt requests enabled
7 to 2	—	All 0	R	Reserved These bits are always read as 0. The write value should always be 0.
1, 0	POE8M[1:0]	00	R/W* ²	POE8 mode 1 and 0 These bits select the input mode of the $\overline{\text{POE8}}$ pin. 00: Accept request on falling edge of POE8 input 01: Accept request when POE8 input has been sampled for 16 P ϕ /8 clock pulses and all are low level. 10: Accept request when POE8 input has been sampled for 16 P ϕ /16 clock pulses and all are low level. 11: Accept request when POE8 input has been sampled for 16 P ϕ /128 clock pulses and all are low level.

Notes: 1. Writing 0 to this bit after reading it as 1 clears the flag and is the only allowed way.
2. Can be modified only once after a power-on reset.

12.3.6 Software Port Output Enable Register (SPOER)

SPOER is an 8-bit readable/writable register that controls high-impedance state of the pins.

Bit:	7	6	5	4	3	2	1	0
	-	-	-	-	-	MTU2S HIZ	MTU2 CH0HIZ	MTU2 CH34HIZ
Initial value:	0	0	0	0	0	0	0	0
R/W:	R	R	R	R	R	R/W	R/W	R/W

Bit	Bit Name	Initial value	R/W	Description
7 to 3	—	All 0	R	Reserved These bits are always read as 0. The write value should always be 0.
2	MTU2SHIZ	0	R/W	MTU2S Output High-Impedance This bit specifies whether to place the high-current pins for the MTU2S in high-impedance state. 0: Does not place the pins in high-impedance state [Clearing conditions] <ul style="list-style-type: none"> • Power-on reset • By writing 0 to MTU2SHIZ after reading MTU2SHIZ = 1 1: Places the pins in high-impedance state [Setting condition] <ul style="list-style-type: none"> • By writing 1 to MTU2SHIZ
1	MTU2CH0HIZ	0	R/W	MTU2 Channel 0 Output High-Impedance This bit specifies whether to place the pins for channel 0 in the MTU2 in high-impedance state. 0: Does not place the pins in high-impedance state [Clearing conditions] <ul style="list-style-type: none"> • Power-on reset • By writing 0 to MTU2CH0HIZ after reading MTU2CH0HIZ = 1 1: Places the pins in high-impedance state [Setting condition] <ul style="list-style-type: none"> • By writing 1 to MTU2CH0HIZ

Bit	Bit Name	Initial value	R/W	Description
0	MTU2CH34HIZ	0	R/W	<p>MTU2 Channel 3 and 4 Output High-Impedance</p> <p>This bit specifies whether to place the high-current pins for the MTU2 in high-impedance state.</p> <p>0: Does not place the pins in high-impedance state [Clearing conditions]</p> <ul style="list-style-type: none"> Power-on reset By writing 0 to MTU2CH34HIZ after reading MTU2CH34HIZ = 1 <p>1: Places the pins in high-impedance state [Setting condition]</p> <ul style="list-style-type: none"> By writing 1 to MTU2CH34HIZ

12.3.7 Port Output Enable Control Register 1 (POECR1)

POECR1 is an 8-bit readable/writable register that controls high-impedance state of the pins.

Bit:	7	6	5	4	3	2	1	0
	-	-	-	-	MTU2 PE3ZE	MTU2 PE2ZE	MTU2 PE1ZE	MTU2 PE0ZE
Initial value:	0	0	0	0	0	0	0	0
R/W:	R	R	R	R	R/W*	R/W*	R/W*	R/W*

Note: * Can be modified only once after a power-on reset.

Bit	Bit Name	Initial value	R/W	Description
7 to 4	—	All 0	R	<p>Reserved</p> <p>These bits are always read as 0. The write value should always be 0.</p>
3	MTU2PE3ZE	0	R/W*	<p>MTU2 PE3 High-Impedance Enable</p> <p>This bit specifies whether to place the PE3/TIOC0D pin for channel 0 in the MTU2 in high-impedance state when either POE8F or MTU2CH0HIZ bit is set to 1.</p> <p>0: Does not place the pin in high-impedance state</p> <p>1: Places the pin in high-impedance state</p>

Bit	Bit Name	Initial value	R/W	Description
2	MTU2PE2ZE	0	R/W*	<p>MTU2 PE2 High-Impedance Enable</p> <p>This bit specifies whether to place the PE2/TIOC0C pin for channel 0 in the MTU2 in high-impedance state when either POE8F or MTU2CH0HIZ bit is set to 1.</p> <p>0: Does not place the pin in high-impedance state 1: Places the pin in high-impedance state</p>
1	MTU2PE1ZE	0	R/W*	<p>MTU2 PE1 High-Impedance Enable</p> <p>This bit specifies whether to place the PE1/TIOC0B pin for channel 0 in the MTU2 in high-impedance state when either POE8F or MTU2CH0HIZ bit is set to 1.</p> <p>0: Does not place the pin in high-impedance state 1: Places the pin in high-impedance state</p>
0	MTU2PE0ZE	0	R/W*	<p>MTU2 PE0 High-Impedance Enable</p> <p>This bit specifies whether to place the PE0/TIOC0A pin for channel 0 in the MTU2 in high-impedance state when either POE8F or MTU2CH0HIZ bit is set to 1.</p> <p>0: Does not place the pin in high-impedance state 1: Places the pin in high-impedance state</p>

Note: * Can be modified only once after a power-on reset.

12.3.8 Port Output Enable Control Register 2 (POECR2)

POECR2 is a 16-bit readable/writable register that controls high-impedance state of the pins.

Bit:	15	14	13	12	11	10	9	8	7	6	5	4	3	2	1	0
	-	MTU2 P1CZE	MTU2 P2CZE	MTU2 P3CZE	-	MTU2S P1CZE	MTU2S P2CZE	MTU2S P3CZE	-	-	-	-	-	-	-	-
Initial value:	0	1	1	1	0	1	1	1	0	0	0	0	0	0	0	0
R/W:	R	R/W*	R/W*	R/W*	R	R/W*	R/W*	R/W*	R	R	R	R	R	R	R	R

Note: * Can be modified only once after a power-on reset.

Bit	Bit Name	Initial value	R/W	Description
15	—	0	R	Reserved This bit is always read as 0. The write value should always be 0.
14	MTU2P1CZE	1	R/W*	MTU2 Port 1 Output Comparison/High-Impedance Enable This bit specifies whether to compare output levels for the MTU2 high-current PE9/TIOC3B and PE11/TIOC3D pins and to place them in high-impedance state when the OSF1 bit is set to 1 while the OCE1 bit is 1 or when any one of the POE0F, POE1F, POE2F, POE3F, and MTU2CH34HIZ bits is set to 1. 0: Does not compare output levels or place the pins in high-impedance state 1: Compares output levels and places the pins in high-impedance state
13	MTU2P2CZE	1	R/W*	MTU2 Port 2 Output Comparison/High-Impedance Enable This bit specifies whether to compare output levels for the MTU2 high-current PE12/TIOC4A and PE14/TIOC4C pins and to place them in high-impedance state when the OSF1 bit is set to 1 while the OCE1 bit is 1 or when any one of the POE0F, POE1F, POE2F, POE3F, and MTU2CH34HIZ bits is set to 1. 0: Does not compare output levels or place the pins in high-impedance state 1: Compares output levels and places the pins in high-impedance state

Bit	Bit Name	Initial value	R/W	Description
12	MTU2P3CZE	1	R/W*	<p>MTU2 Port 3 Output Comparison/High-Impedance Enable</p> <p>This bit specifies whether to compare output levels for the MTU2 high-current PE13/TIOC4B and PE15/TIOC4D pins and to place them in high-impedance state when the OSF1 bit is set to 1 while the OCE1 bit is 1 or when any one of the POE0F, POE1F, POE2F, POE3F, and MTU2CH34HIZ bits is set to 1.</p> <p>0: Does not compare output levels or place the pins in high-impedance state</p> <p>1: Compares output levels and places the pins in high-impedance state</p>
11	—	0	R	<p>Reserved</p> <p>This bit is always read as 0. The write value should always be 0.</p>
10	MTU2SP1CZE	1	R/W*	<p>MTU2S Port 1 Output Comparison/High-Impedance Enable</p> <p>This bit specifies whether to compare output levels for the MTU2S high-current PE16/TIOC3BS and PE17/TIOC3DS pins and to place them in high-impedance state when the OSF2 bit is set to 1 while the OCE2 bit is 1 or when any one of the POE4F, POE5F, POE6F, POE7F, and MTU2SHIZ bits is set to 1.</p> <p>0: Does not compare output levels or place the pins in high-impedance state</p> <p>1: Compares output levels and places the pins in high-impedance state</p>

Bit	Bit Name	Initial value	R/W	Description
9	MTU2SP2CZE	1	R/W*	<p>MTU2S Port 2 Output Comparison/High-Impedance Enable</p> <p>This bit specifies whether to compare output levels for the MTU2S high-current PE18/TIOC4AS and PE20/TIOC4CS pins and to place them in high-impedance state when the OSF2 bit is set to 1 while the OCE2 bit is 1 or when any one of the POE4F, POE5F, POE6F, POE7F, and MTU2SHIZ bits is set to 1.</p> <p>0: Does not compare output levels or place the pins in high-impedance state</p> <p>1: Compares output levels and places the pins in high-impedance state</p>
8	MTU2SP3CZE	1	R/W*	<p>MTU2S Port 3 Output Comparison/High-Impedance Enable</p> <p>This bit specifies whether to compare output levels for the MTU2S high-current PE19/TIOC4BS and PE21/TIOC4DS pins and to place them in high-impedance state when the OSF2 bit is set to 1 while the OCE2 bit is 1 or when any one of the POE4F, POE5F, POE6F, POE7F, and MTU2SHIZ bits is set to 1.</p> <p>0: Does not compare output levels or place the pins in high-impedance state</p> <p>1: Compares output levels and places the pins in high-impedance state</p>
7 to 0	—	All 0	R	<p>Reserved</p> <p>These bits are always read as 0. The write value should always be 0.</p>

Note: * Can be modified only once after a power-on reset.

12.4 Operation

Table 12.4 shows the target pins for high-impedance control and conditions to place the pins in high-impedance state.

Table 12.4 Target Pins and Conditions for High-Impedance Control

Pins	Conditions	Detailed Conditions
MTU2 high-current pins (PE9/TIOC3B and PE11/TIOC3D)	Input level detection, output level comparison, or SPOER setting	MTU2P1CZE • ((POE3F + POE2F + POE1F + POE0F) + (OSF1 • OCE1) + (MTU2CH34HIZ))
MTU2 high-current pins (PE12/TIOC4A and PE14/TIOC4C)	Input level detection, output level comparison, or SPOER setting	MTU2P2CZE • ((POE3F + POE2F + POE1F + POE0F) + (OSF1 • OCE1) + (MTU2CH34HIZ))
MTU2 high-current pins (PE13/TIOC4B and PE15/TIOC4D)	Input level detection, output level comparison, or SPOER setting	MTU2P3CZE • ((POE3F + POE2F + POE1F + POE0F) + (OSF1 • OCE1) + (MTU2CH34HIZ))
MTU2S high-current pins (PE16/TIOC3BS and PE17/TIOC3DS)	Input level detection, output level comparison, or SPOER setting	MTU2SP1CZE • ((POE4F + POE5F + POE6F + POE7F) + (OSF2 • OCE2) + (MTU2SHIZ))
MTU2S high-current pins (PE18/TIOC4AS and PE20/TIOC4CS)	Input level detection, output level comparison, or SPOER setting	MTU2SP2CZE • ((POE4F + POE5F + POE6F + POE7F) + (OSF2 • OCE2) + (MTU2SHIZ))
MTU2S high-current pins (PE19/TIOC4BS and PE21/TIOC4DS)	Input level detection, output level comparison, or SPOER setting	MTU2SP3CZE • ((POE4F + POE5F + POE6F + POE7F) + (OSF2 • OCE2) + (MTU2SHIZ))
MTU2 channel 0 pin (PE0/TIOC0A)	Input level detection or SPOER setting	MTU2PE0ZE ((POE8F • POE8E) + (MTU2CH0HIZ))
MTU2 channel 0 pin (PE1/TIOC0B)	Input level detection or SPOER setting	MTU2PE1ZE ((POE8F • POE8E) + (MTU2CH0HIZ))
MTU2 channel 0 pin (PE2/TIOC0C)	Input level detection or SPOER setting	MTU2PE2ZE ((POE8F • POE8E) + (MTU2CH0HIZ))
MTU2 channel 0 pin (PE3/TIOC0D)	Input level detection or SPOER setting	MTU2PE3ZE ((POE8F • POE8E) + (MTU2CH0HIZ))

12.4.1 Input Level Detection Operation

If the input conditions set by ICSR1 to ICSR3 occur on the $\overline{\text{POE0}}$ to $\overline{\text{POE8}}$ pins, the high-current pins and the pins for channel 0 of the MTU2 are placed in high-impedance state. Note however, that these high-current and MTU2 pins enter high-impedance state only when general input/output function, MTU2 function, or MTU2S function is selected for these pins.

(1) Falling Edge Detection

When a change from a high to low level is input to the $\overline{\text{POE0}}$ to $\overline{\text{POE8}}$ pins, the high-current pins and the pins for channel 0 of the MTU2 are placed in high-impedance state. Figure 12.2 shows a sample timing after the level changes in input to the $\overline{\text{POE0}}$ to $\overline{\text{POE8}}$ pins until the respective pins enter high-impedance state.

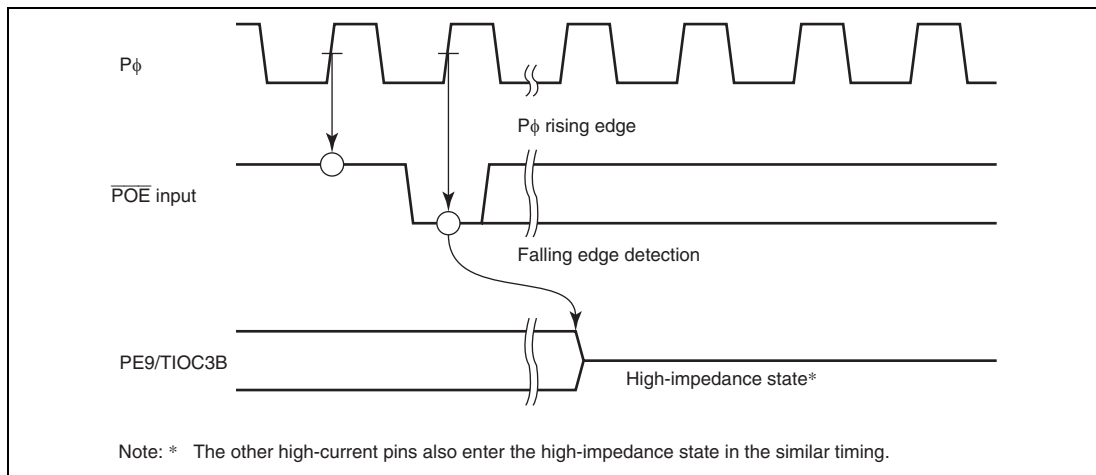

Figure 12.2 Falling Edge Detection

(2) Low-Level Detection

Figure 12.3 shows the low-level detection operation. Sixteen continuous low levels are sampled with the sampling clock selected by ICSR1 to ICSR3. If even one high level is detected during this interval, the low level is not accepted.

The timing when the high-current pins enter the high-impedance state after the sampling clock is input is the same in both falling-edge detection and in low-level detection.

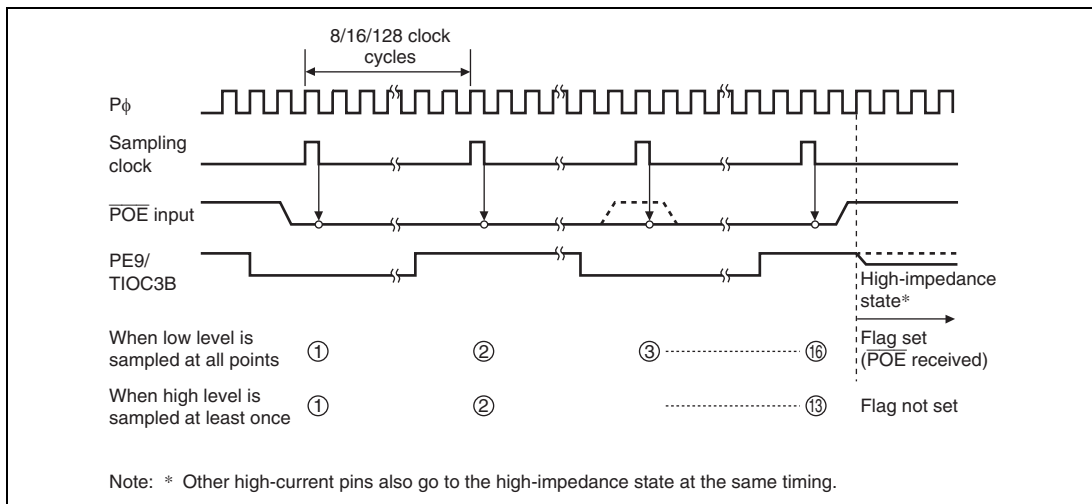

Figure 12.3 Low-Level Detection Operation

12.4.2 Output-Level Compare Operation

Figure 12.4 shows an example of the output-level compare operation for the combination of TIOC3B and TIOC3D. The operation is the same for the other pin combinations.

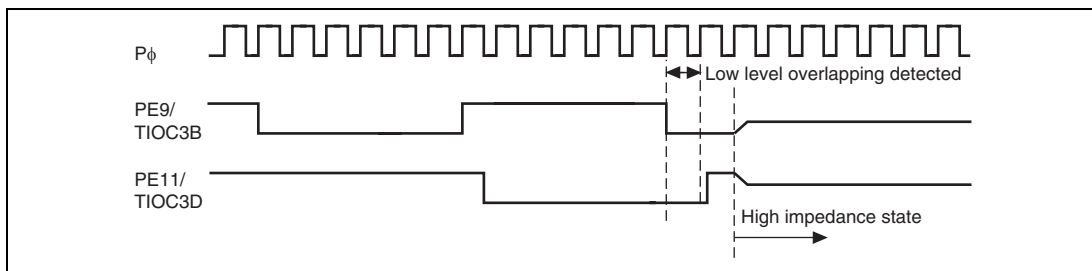

Figure 12.4 Output-Level Compare Operation

12.4.3 Release from High-Impedance State

High-current pins that have entered high-impedance state due to input-level detection can be released either by returning them to their initial state with a power-on reset, or by clearing all of the flags in bits 12 to 15 (POE0F to POE8F) of ICSR1 to ICSR3. However, note that when low-level sampling is selected by bits 0 to 7 in ICSR1 to ICSR3, just writing 0 to a flag is ignored (the flag is not cleared); flags can be cleared by writing 0 to it only after a high level is input to the POE pin and is sampled.

High-current pins that have entered high-impedance state due to output-level detection can be released either by returning them to their initial state with a power-on reset, or by clearing the flag in bit 15 (OCF1 and OCF2) in OCSR1 and OCSR2. However, note that just writing 0 to a flag is ignored (the flag is not cleared); flags can be cleared only after an inactive level is output from the high-current pins. Inactive-level outputs can be achieved by setting the MTU2 and MTU2S internal registers.

12.5 Interrupts

The POE issues a request to generate an interrupt when the specified condition is satisfied during input level detection or output level comparison. Table 12.5 shows the interrupt sources and their conditions.

Table 12.5 Interrupt Sources and Conditions

Name	Interrupt Source	Interrupt Flag	Condition
OEI1	Output enable interrupt 1	POE3F, POE2F, POE1F, POE0F, and OSF1	$PIE1 \bullet (POE3F + POE2F + POE1F + POE0F) + OIE1 \bullet OSF1$
OEI3	Output enable interrupt 3	POE8F	$PIE3 \bullet POE8F$
OEI2	Output enable interrupt 2	POE4F, POE5F, POE6F, POE7F, and OSF2	$PIE2 \bullet (POE4F + POE5F + POE6F + POE7F) + OIE2 \bullet OSF2$

12.6 Usage Note

12.6.1 Pin State When a Power-On Reset Is Issued from the Watchdog Timer

When a power-on reset is issued from the watchdog timer (WDT), initialization of the pin function controller (PFC) sets initial values that select the general input function for the I/O ports. However, when a power-on reset is issued from the WDT while a pin is being handled as high impedance by the port output enable (POE), the pin is placed in the output state for one cycle of the peripheral clock ($P\phi$), after which the function is switched to general input.

This also occurs when a power-on reset is issued from the WDT for pins that are being handled as high impedance due to short-circuit detection by the MTU2 and MTU2S.

Figure 12.5 shows the state of a pin for which the POE input has selected high impedance handling with the timer output selected when a power-on reset is issued from the WDT.

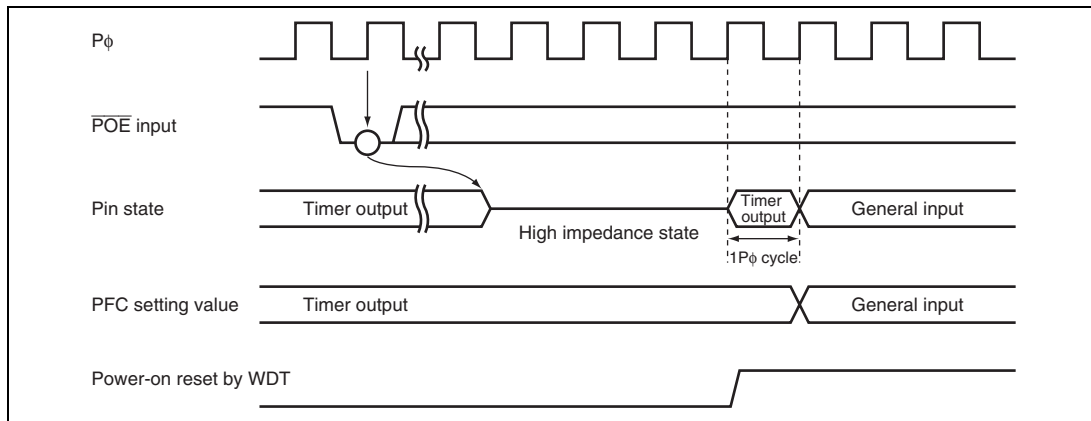

Figure 12.5 Pin State When a Power-On Reset Is Issued from the Watchdog Timer

Section 13 Watchdog Timer (WDT)

This LSI includes the watchdog timer (WDT).

This LSI can be reset by the overflow of the counter when the value of the counter has not been updated because of a system runaway.

The watchdog timer (WDT) is a single-channel timer that uses a peripheral clock as an input and counts the clock settling time when revoking software standby mode. It can also be used as an interval timer.

13.1 Features

- Can be used to ensure the clock settling time: Use the WDT to revoke software standby mode.
- Can switch between watchdog timer mode and interval timer mode.
- Generates internal resets in watchdog timer mode: Internal resets occur after counter overflow.
- An interrupt is generated in interval timer mode
An interval timer interrupt is generated when the counter overflows.
- Choice of eight counter input clocks
Eight clocks ($\times 1$ to $\times 1/4096$) that are obtained by dividing the peripheral clock can be chosen.
- Choice of two resets
Power-on reset and manual reset are available.

Figure 13.1 shows a block diagram of the WDT.

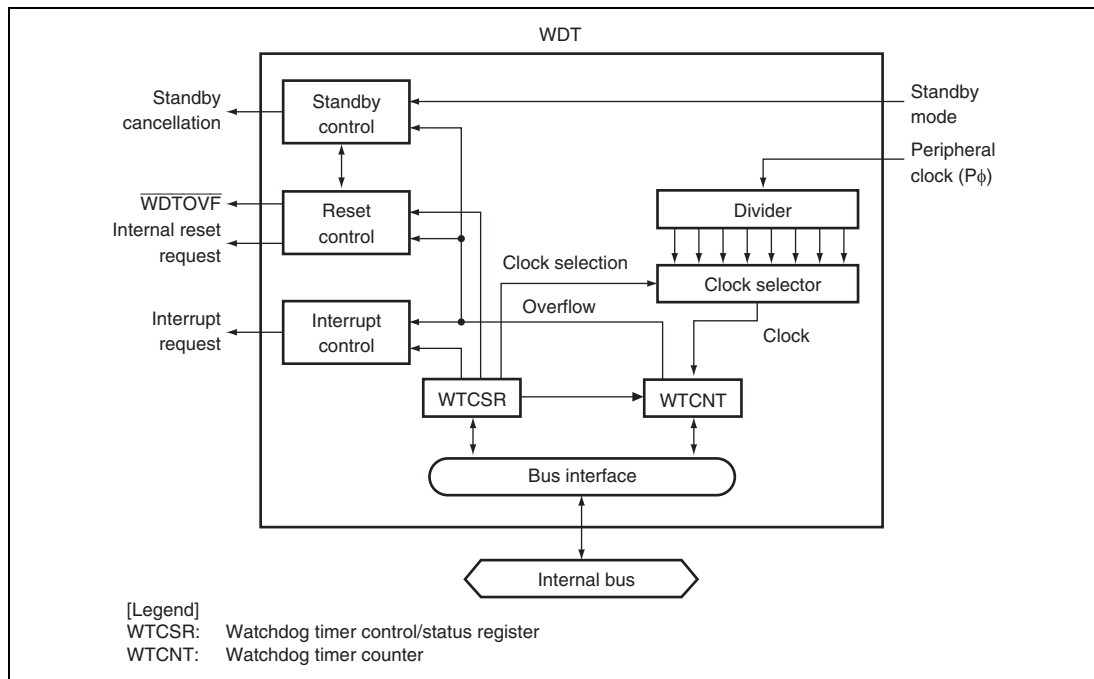

Figure 13.1 Block Diagram of WDT

13.2 Input/Output Pin for WDT

Table 13.1 lists the WDT pin configuration.

Table 13.1 WDT Pin Configuration

Pin Name	Abbreviation	I/O	Description
Watchdog timer overflow	$\overline{\text{WDTOVF}}$	Output	When an overflow occurs in watchdog timer mode, an internal reset is generated and this pin outputs the low level for one clock cycle specified by the CKS2 to CKS0 bits in WTCSR.

13.3 Register Descriptions

The WDT has the following two registers. Refer to section 23, List of Registers, for the details of the addresses of these registers and the state of registers in each operating mode.

Table 13.2 Register Configuration

Register Name	Abbreviation	R/W	Initial Value	Address	Access Size
Watchdog timer counter	WTCNT	R/W	H'00	H'FFFFFFE810	8, 16
Watchdog timer control/status register	WTCSR	R/W	H'00	H'FFFFFFE812	8, 16

13.3.1 Watchdog Timer Counter (WTCNT)

WTCNT is an 8-bit readable/writable register that increments on the selected clock. When an overflow occurs, it generates a reset in watchdog timer mode and an interrupt in interval time mode. The WTCNT counter is not initialized by an internal reset due to the WDT overflow. The WTCNT counter is initialized to H'00 only by a power-on reset using the $\overline{\text{RES}}$ pin. Use a word access to write to the WTCNT counter, with H'5A in the upper byte. Use a byte access to read WTCNT.

Note: WTCNT differs from other registers in that it is more difficult to write to. See section 13.3.3, Notes on Register Access, for details.

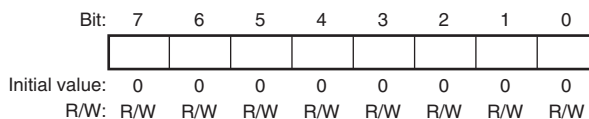

13.3.2 Watchdog Timer Control/Status Register (WTCSR)

WTCSR is an 8-bit readable/writable register composed of bits to select the clock used for the count, bits to select the timer mode, and overflow flags. WTCSR holds its value in an internal reset due to the WDT overflow. WTCSR is initialized to H'00 only by a power-on reset using the $\overline{\text{RES}}$ pin.

When used to count the clock settling time for revoking a software standby, it retains its value after counter overflow. Use a word access to write to WTCSR, with H'A5 in the upper byte. Use a byte access to read WTCSR.

Note: WTCSR differs from other registers in that it is more difficult to write to. See section 13.3.3, Notes on Register Access, for details.

Bit:	7	6	5	4	3	2	1	0
	TME	WT/IT	RSTS	WOVF	IOVF	CKS[2:0]		
Initial value:	0	0	0	0	0	0	0	0
R/W:	R/W	R/W	R/W	R/W	R/W	R/W	R/W	R/W

Bit	Bit Name	Initial Value	R/W	Description
7	TME	0	R/W	Timer Enable Starts and stops timer operation. Clear this bit to 0 when using the WDT to revoke software standby mode. 0: Timer disabled: Count-up stops and WTCNT value is retained 1: Timer enabled
6	WT/IT	0	R/W	Timer Mode Select Selects whether to use the WDT as a watchdog timer or an interval timer. 0: Interval timer mode 1: Watchdog timer mode Note: If WT/IT is modified when the WDT is operating, the up-count may not be performed correctly.

Bit	Bit Name	Initial Value	R/W	Description
5	RSTS	0	R/W	<p>Reset Select</p> <p>Selects the type of reset when the WTCNT overflows in watchdog timer mode. In interval timer mode, this setting is ignored.</p> <p>0: Power-on reset 1: Manual reset</p>
4	WOVF	0	R/W	<p>Watchdog Timer Overflow</p> <p>Indicates that the WTCNT has overflowed in watchdog timer mode. This bit is not set in interval timer mode.</p> <p>0: No overflow 1: WTCNT has overflowed in watchdog timer mode</p>
3	IOVF	0	R/W	<p>Interval Timer Overflow</p> <p>Indicates that the WTCNT has overflowed in interval timer mode. This bit is not set in watchdog timer mode.</p> <p>0: No overflow 1: WTCNT has overflowed in interval timer mode</p>
2 to 0	CKS[2:0]	000	R/W	<p>Clock Select 2 to 0</p> <p>These bits select the clock to be used for the WTCNT count from the eight types obtainable by dividing the peripheral clock ($P\phi$). The overflow period that is shown inside the parenthesis in the table is the value when the peripheral clock ($P\phi$) is 40 MHz.</p> <p>000: $P\phi$ (6.4 μs) 001: $P\phi/4$ (25.6 μs) 010: $P\phi/16$ (102.4 μs) 011: $P\phi/32$ (204.8 μs) 100: $P\phi/64$ (409.6 μs) 101: $P\phi/256$ (1.64 ms) 110: $P\phi/1024$ (6.55 ms) 111: $P\phi/4096$ (26.21 ms)</p> <p>Note: If bits CKS2 to CKS0 are modified when the WDT is operating, the up-count may not be performed correctly. Ensure that these bits are modified only when the WDT is not operating.</p>

13.3.3 Notes on Register Access

The watchdog timer counter (WTCNT) and watchdog timer control/status register (WTCSR) are more difficult to write to than other registers. The procedure for writing to these registers is given below.

Writing to WTCNT and WTCSR: These registers must be written by a word transfer instruction. They cannot be written by a byte or longword transfer instruction. When writing to WTCNT, set the upper byte to H'5A and transfer the lower byte as the write data, as shown in figure 13.2. When writing to WTCSR, set the upper byte to H'A5 and transfer the lower byte as the write data. This transfer procedure writes the lower byte data to WTCNT or WTCSR.

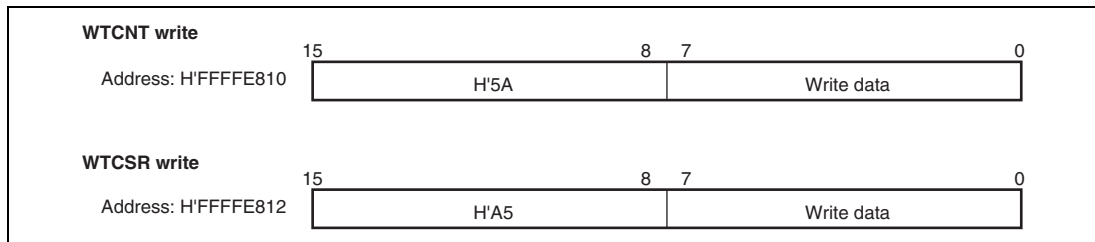

Figure 13.2 Writing to WTCNT and WTCSR

13.4 Operation

13.4.1 Revoking Software Standbys

The WDT can be used to revoke software standby mode with an NMI interrupt or external interrupt (IRQ). The procedure is described below. (The WDT does not run when resets are used for revoking, so keep the $\overline{\text{RES}}$ pin low until the clock stabilizes.)

1. Before transition to software standby mode, always clear the TME bit in WTCSR to 0. When the TME bit is 1, an erroneous reset or interval timer interrupt may be generated when the count overflows.
2. Set the type of count clock used in the CKS2 to CKS0 bits in WTCSR and the initial values for the counter in the WTCNT counter. These values should ensure that the time till count overflow is longer than the clock oscillation settling time.
3. Transition to software standby mode by executing a SLEEP instruction to stop the clock.
4. The WDT starts counting by detecting a change in the level input to the NMI or IRQ pin.
5. When the WDT count overflows, the CPG starts supplying the clock and the LSI resumes operation. The WOVF flag in WTCSR is not set when this happens.

13.4.2 Using Watchdog Timer Mode

While operating in watchdog timer mode, the WDT generates an internal reset of the type specified by the RSTS bit in WTCSR and asserts a signal through the $\overline{\text{WDTOVF}}$ pin every time the counter overflows.

1. Set the WT/IT bit in WTCSR to 1, set the reset type in the RSTS bit, set the type of count clock in the CKS2 to CKS0 bits, and set the initial value of the counter in the WTCNT counter.
2. Set the TME bit in WTCSR to 1 to start the count in watchdog timer mode.
3. While operating in watchdog timer mode, rewrite the counter periodically to prevent the counter from overflowing.
4. When the counter overflows, the WDT sets the WOVF flag in WTCSR to 1, asserts a signal through the $\overline{\text{WDTOVF}}$ pin for one cycle of the count clock specified by the CKS2 to CKS0 bits, and generates a reset of the type specified by the RSTS bit. The counter then resumes counting.

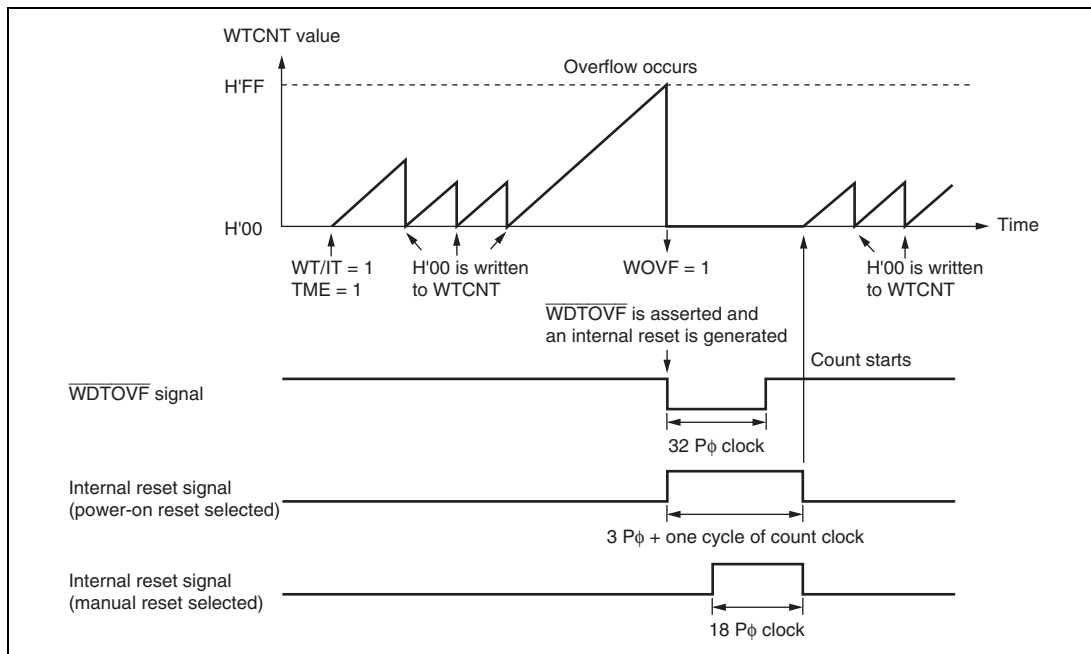

Figure 13.3 Operation in Watchdog Timer Mode
(When WTCNT Count Clock Is Specified to Pφ/32 by CKS2 to CKS0)

13.4.3 Using Interval Timer Mode

When operating in interval timer mode, interval timer interrupts are generated at every overflow of the counter. This enables interrupts to be generated at set periods.

1. Clear the WT/IT bit in WTCSR to 0, set the type of count clock in the CKS2 to CKS0 bits, and set the initial value of the counter in the WTCNT counter.
2. Set the TME bit in WTCSR to 1 to start the count in interval timer mode.
3. When the counter overflows, the WDT sets the IOVF flag in WTCSR to 1 and an interval timer interrupt request is sent to the INTC. The counter then resumes counting.

13.5 Interrupt Source

The WDT has one interrupt source: the interval timer interrupt (ITI).

Table 13.3 shows this interrupt source. An interval timer interrupt (ITI) is generated when the interval timer overflow flag bit (IOVF) in the watchdog timer control status register (WTSCR) is set to 1.

The interrupt request is canceled by clearing the interrupt flag to 0.

Table 13.3 Interrupt Source

Name	Interrupt Source	Interrupt Enable Bit	Interrupt Flag Bit
ITI	Interval timer interrupt	—	Interval timer overflow flag (IOVF)

13.6 Usage Note

13.6.1 WTCNT Setting Value

If WTCNT is set to H'FF in interval timer mode, overflow does not occur when WTCNT changes from H'FF to H'00 after one cycle of count clock, but overflow occurs when WTCNT changes from H'FF to H'00 after 257 cycles of count clock.

If WTCNT is set to H'FF in watchdog timer mode, overflow occurs when WTCNT changes from H'FF to H'00 after one cycle of count clock.

Section 14 Serial Communication Interface (SCI)

This LSI has three independent serial communication interface (SCI) channels. The SCI can handle both asynchronous and clock synchronous serial communication. In asynchronous serial communication mode, serial data communication can be carried out with standard asynchronous communication chips such as a Universal Asynchronous Receiver/Transmitter (UART) or Asynchronous Communication Interface Adapter (ACIA). A function is also provided for serial communication between processors (multiprocessor communication function).

14.1 Features

- Choice of asynchronous or clock synchronous serial communication mode
- Asynchronous mode:
 - Serial data communication is performed by start-stop in character units. The SCIF can communicate with a universal asynchronous receiver/transmitter (UART), an asynchronous communication interface adapter (ACIA), or any other communications chip that employs a standard asynchronous serial system. There are twelve selectable serial data communication formats.
 - Data length: 7 or 8 bits
 - Stop bit length: 1 or 2 bits
 - Parity: Even, odd, or none
 - Multiprocessor communications
 - Receive error detection: Parity, overrun, and framing errors
 - Break detection: Break is detected by reading the RXD pin level directly when a framing error occurs.
- Clock synchronous mode:
 - Serial data communication is synchronized with a clock signal. The SCIF can communicate with other chips having a clock synchronous communication function.
 - Data length: 8 bits
 - Receive error detection: Overrun errors
- Full duplex communication: The transmitting and receiving sections are independent, so the SCI can transmit and receive simultaneously. Both sections use double buffering, so high-speed continuous data transfer is possible in both the transmit and receive directions.
- On-chip baud rate generator with selectable bit rates
- Internal or external transmit/receive clock source: From either baud rate generator (internal clock) or SCK pin (external clock)
- Choice of LSB-first or MSB-first data transfer (except for 7-bit data in asynchronous mode)

- Four types of interrupts: There are four interrupt sources, transmit-data-empty, transmit end, receive-data-full, and receive error interrupts, and each interrupt can be requested independently. The data transfer controller (DTC) can be activated by the transmit-data-empty interrupt or receive-data-full interrupt to transfer data.
- Module standby mode can be set

Figure 14.1 shows a block diagram of the SCI.

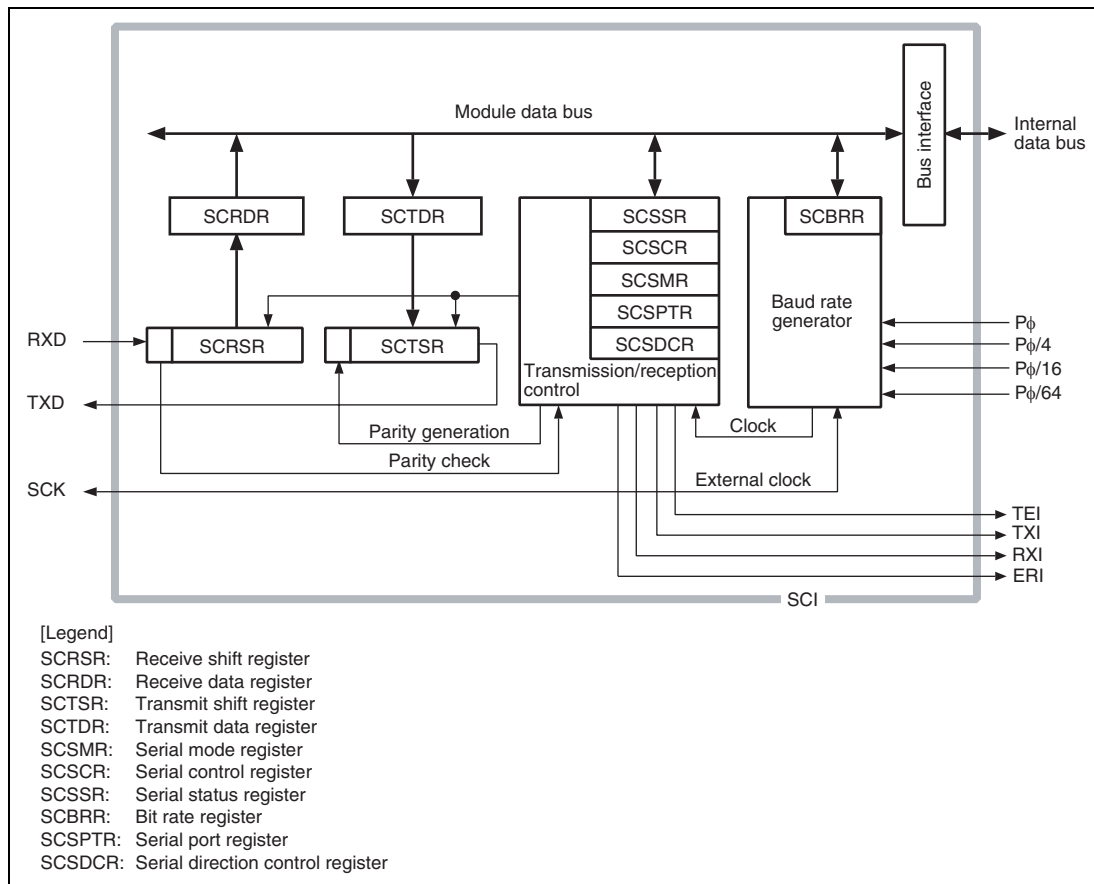

Figure 14.1 Block Diagram of SCI

14.2 Input/Output Pins

The SCI has the serial pins summarized in table 14.1.

Table 14.1 Pin Configuration

Channel	Pin Name*	I/O	Function
0	SCK0	I/O	SCI0 clock input/output
	RXD0	Input	SCI0 receive data input
	TXD0	Output	SCI0 transmit data output
1	SCK1	I/O	SCI1 clock input/output
	RXD1	Input	SCI1 receive data input
	TXD1	Output	SCI1 transmit data output
2	SCK2	I/O	SCI2 clock input/output
	RXD2	Input	SCI2 receive data input
	TXD2	Output	SCI2 transmit data output

Note: * Pin names SCK, RXD, and TXD are used in the description for all channels, omitting the channel designation.

14.3 Register Descriptions

The SCI has the following registers for each channel. For details on register addresses and register states during each processing, refer to section 23, List of Registers.

Table 14.2 Register Configuration

Chan- nel	Register Name	Abbrevia- tion	R/W	Initial Value	Address	Access Size
0	Serial mode register_0	SCSMR_0	R/W	H'00	H'FFFFC000	8
	Bit rate register_0	SCBRR_0	R/W	H'FF	H'FFFFC002	8
	Serial control register_0	SCSCR_0	R/W	H'00	H'FFFFC004	8
	Transmit data register_0	SCTDR_0	—	—	H'FFFFC006	8
	Serial status register_0	SCSSR_0	R/W	H'84	H'FFFFC008	8
	Receive data register_0	SCRDR_0	—	—	H'FFFFC00A	8
	Serial direction control register_0	SCSDCR_0	R/W	H'F2	H'FFFFC00C	8
	Serial port register_0	SCSPTR_0	R/W	H'0x	H'FFFFC00E	8
1	Serial mode register_1	SCSMR_1	R/W	H'00	H'FFFFC080	8
	Bit rate register_1	SCBRR_1	R/W	H'FF	H'FFFFC082	8
	Serial control register_1	SCSCR_1	R/W	H'00	H'FFFFC084	8
	Transmit data register_1	SCTDR_1	—	—	H'FFFFC086	8
	Serial status register_1	SCSSR_1	R/W	H'84	H'FFFFC088	8
	Receive data register_1	SCRDR_1	—	—	H'FFFFC08A	8
	Serial direction control register_1	SCSDCR_1	R/W	H'F2	H'FFFFC08C	8
	Serial port register_1	SCSPTR_1	R/W	H'0x	H'FFFFC08E	8
2	Serial mode register_2	SCSMR_2	R/W	H'00	H'FFFFC100	8
	Bit rate register_2	SCBRR_2	R/W	H'FF	H'FFFFC102	8
	Serial control register_2	SCSCR_2	R/W	H'00	H'FFFFC104	8
	Transmit data register_2	SCTDR_2	—	—	H'FFFFC106	8
	Serial status register_2	SCSSR_2	R/W	H'84	H'FFFFC108	8
	Receive data register_2	SCRDR_2	—	—	H'FFFFC10A	8
	Serial direction control register_2	SCSDCR_2	R/W	H'F2	H'FFFFC10C	8
	Serial port register_2	SCSPTR_2	R/W	H'0x	H'FFFFC10E	8

14.3.1 Receive Shift Register (SCRSR)

SCRSR receives serial data. Data input at the RXD pin is loaded into SCRSR in the order received, LSB (bit 0) first, converting the data to parallel form. When one byte has been received, it is automatically transferred to SCRDR. The CPU cannot read or write to SCRSR directly.

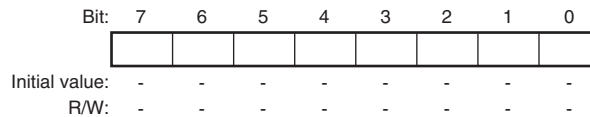

14.3.2 Receive Data Register (SCRDR)

SCRDR is a register that stores serial receive data. After receiving one byte of serial data, the SCI transfers the received data from the receive shift register (SCRSR) into SCRDR for storage and completes operation. After that, SCRSR is ready to receive data.

Since SCRSR and SCRDR work as a double buffer in this way, data can be received continuously.

SCRDR is a read-only register and cannot be written to by the CPU.

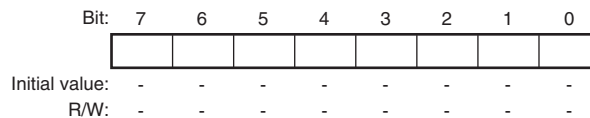

14.3.3 Transmit Shift Register (SCTSR)

SCTSR transmits serial data. The SCI loads transmit data from the transmit data register (SCTDR) into SCTSR, then transmits the data serially from the TXD pin, LSB (bit 0) first. After transmitting one data byte, the SCI automatically loads the next transmit data from SCTDR into SCTSR and starts transmitting again. If the TDRE flag in the serial status register (SCSSR) is set to 1, the SCI does not transfer data from SCTDR to SCTSR. The CPU cannot read or write to SCTSR directly.

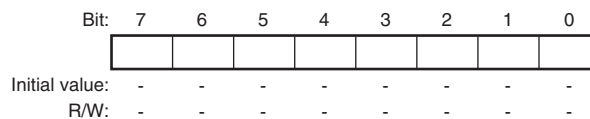

14.3.4 Transmit Data Register (SCTDR)

SCTDR is an 8-bit register that stores data for serial transmission. When the SCI detects that the transmit shift register (SCTSR) is empty, it moves transmit data written in the SCTDR into SCTSR and starts serial transmission. If the next transmit data has been written to SCTDR during serial transmission from SCTSR, the SCI can transmit data continuously. SCTDR can always be written or read to by the CPU.

Bit:	7	6	5	4	3	2	1	0
Initial value:	-	-	-	-	-	-	-	-
R/W:	-	-	-	-	-	-	-	-

14.3.5 Serial Mode Register (SCSMR)

SCSMR is an 8-bit register that specifies the SCI serial communication format and selects the clock source for the baud rate generator.

The CPU can always read and write to SCSMR.

Bit:	7	6	5	4	3	2	1	0
	C/ \bar{A}	CHR	PE	O/ \bar{E}	STOP	MP	CKS[1:0]	
Initial value:	0	0	0	0	0	0	0	0
R/W:	R/W	R/W	R/W	R/W	R/W	R/W	R/W	R/W

Bit	Bit Name	Initial value	R/W	Description
7	C/ \bar{A}	0	R/W	Communication Mode Selects whether the SCI operates in asynchronous or clock synchronous mode. 0: Asynchronous mode 1: Clock synchronous mode
6	CHR	0	R/W	Character Length Selects 7-bit or 8-bit data in asynchronous mode. In the clock synchronous mode, the data length is always eight bits, regardless of the CHR setting. When 7-bit data is selected, the MSB (bit 7) of the transmit data register is not transmitted. 0: 8-bit data 1: 7-bit data

Bit	Bit Name	Initial value	R/W	Description
5	PE	0	R/W	<p>Parity Enable</p> <p>Selects whether to add a parity bit to transmit data and to check the parity of receive data, in asynchronous mode. In clock synchronous mode, a parity bit is neither added nor checked, regardless of the PE setting.</p> <p>0: Parity bit not added or checked 1: Parity bit added and checked*</p> <p>Note: * When PE is set to 1, an even or odd parity bit is added to transmit data, depending on the parity mode (O/E) setting. Receive data parity is checked according to the even/odd (O/E) mode setting.</p>
4	O/E	0	R/W	<p>Parity mode</p> <p>Selects even or odd parity when parity bits are added and checked. The O/E setting is used only in asynchronous mode and only when the parity enable bit (PE) is set to 1 to enable parity addition and checking. The O/E setting is ignored in clock synchronous mode, or in asynchronous mode when parity addition and checking is disabled.</p> <p>0: Even parity 1: Odd parity</p> <p>If even parity is selected, the parity bit is added to transmit data to make an even number of 1s in the transmitted character and parity bit combined. Receive data is checked to see if it has an even number of 1s in the received character and parity bit combined.</p> <p>If odd parity is selected, the parity bit is added to transmit data to make an odd number of 1s in the transmitted character and parity bit combined. Receive data is checked to see if it has an odd number of 1s in the received character and parity bit combined.</p>

Bit	Bit Name	Initial value	R/W	Description
3	STOP	0	R/W	<p>Stop Bit Length</p> <p>Selects one or two bits as the stop bit length in asynchronous mode. This setting is used only in asynchronous mode. It is ignored in clock synchronous mode because no stop bits are added.</p> <p>0: One stop bit*¹ 1: Two stop bits*²</p> <p>When receiving, only the first stop bit is checked, regardless of the STOP bit setting. If the second stop bit is 1, it is treated as a stop bit, but if the second stop bit is 0, it is treated as the start bit of the next incoming character.</p> <p>Notes: 1. When transmitting, a single 1-bit is added at the end of each transmitted character. 2. When transmitting, two 1 bits are added at the end of each transmitted character.</p>
2	MP	0	R/W	<p>Multiprocessor Mode (only in asynchronous mode)</p> <p>Enables or disables multiprocessor mode. The PE and O/\bar{E} bit settings are ignored in multiprocessor mode.</p> <p>0: Multiprocessor mode disabled 1: Multiprocessor mode enabled</p>
1, 0	CKS[1:0]	00	R/W	<p>Clock Select 1 and 0</p> <p>Select the internal clock source of the on-chip baud rate generator. Four clock sources are available. Pϕ, Pϕ/4, Pϕ/16 and Pϕ/64. For further information on the clock source, bit rate register settings, and baud rate, see section 14.3.10, Bit Rate Register (SCBRR).</p> <p>00: Pϕ 01: Pϕ/4 10: Pϕ/16 11: Pϕ/64</p> <p>Note: Pϕ: Peripheral clock</p>

14.3.6 Serial Control Register (SCSCR)

SCSCR is an 8-bit register that enables or disables SCI transmission/reception and interrupt requests and selects the transmit/receive clock source. The CPU can always read and write to SCSCR.

Bit:	7	6	5	4	3	2	1	0
	TIE	RIE	TE	RE	MPIE	TEIE	CKE[1:0]	
Initial value:	0	0	0	0	0	0	0	0
R/W:	R/W	R/W	R/W	R/W	R/W	R/W	R/W	R/W

Bit	Bit Name	Initial value	R/W	Description
7	TIE	0	R/W	<p>Transmit Interrupt Enable</p> <p>Enables or disables a transmit-data-empty interrupt (TXI) to be issued when the TDRE flag in the serial status register (SCSSR) is set to 1 after serial transmit data is sent from the transmit data register (SCTDR) to the transmit shift register (SCTSR).</p> <p>TXI can be canceled by clearing the TDRE flag to 0 after reading TDRE = 1 or by clearing the TIE bit to 0.</p> <p>0: Transmit-data-empty interrupt request (TXI) is disabled</p> <p>1: Transmit-data-empty interrupt request (TXI) is enabled</p>
6	RIE	0	R/W	<p>Receive Interrupt Enable</p> <p>Enables or disables a receive-data-full interrupt (RXI) and a receive error interrupt (ERI) to be issued when the RDRF flag in SCSSR is set to 1 after the serial data received is transferred from the receive shift register (SCRSR) to the receive data register (SCRDR).</p> <p>RXI can be canceled by clearing the RDRF flag after reading RDRF = 1. ERI can be canceled by clearing the FER, PER, or ORER flag to 0 after reading 1 from the flag. Both RXI and ERI can also be canceled by clearing the RIE bit to 0.</p> <p>0: Receive-data-full interrupt (RXI) and receive-error interrupt (ERI) requests are disabled</p> <p>1: Receive-data-full interrupt (RXI) and receive-error interrupt (ERI) requests are enabled</p>

Bit	Bit Name	Initial value	R/W	Description
5	TE	0	R/W	<p>Transmit Enable</p> <p>Enables or disables the SCI serial transmitter.</p> <p>0: Transmitter disabled*¹</p> <p>1: Transmitter enabled*²</p> <p>Notes: 1. The TDRE flag in SCSSR is fixed at 1.</p> <p>2. Serial transmission starts after writing transmit data into SCTDR and clearing the TDRE flag in SCSSR to 0 while the transmitter is enabled. Select the transmit format in the serial mode register (SCSMR) before setting TE to 1.</p>
4	RE	0	R/W	<p>Receive Enable</p> <p>Enables or disables the SCI serial receiver.</p> <p>0: Receiver disabled*¹</p> <p>1: Receiver enabled*²</p> <p>Notes: 1. Clearing RE to 0 does not affect the receive flags (RDRF, FER, PER, and ORER). These flags retain their previous values.</p> <p>2. Serial reception starts when a start bit is detected in asynchronous mode, or synchronous clock input is detected in clock synchronous mode. Select the receive format in SCSMR before setting RE to 1.</p>
3	MPIE	0	R/W	<p>Multiprocessor Interrupt Enable (only when MP = 1 in SCSMR in asynchronous mode)</p> <p>When this bit is set to 1, receive data in which the multiprocessor bit is 0 is skipped and setting of the RDRF, FER, and ORER status flags in SCSSR is prohibited. On receiving data in which the multiprocessor bit is 1, this bit is automatically cleared to 0 and normal receiving operation is resumed. For details, refer to section 14.4.4, Multiprocessor Communication Function.</p>

Bit	Bit Name	Initial value	R/W	Description
2	TEIE	0	R/W	<p>Transmit End Interrupt Enable</p> <p>Enables or disables a transmit end interrupt (TEI) to be issued when no valid transmit data is found in SCTDR during MSB data transmission.</p> <p>TEI can be canceled by clearing the TEND flag to 0 (by clearing the TDRE flag in SCSSR to 0 after reading TDRE = 1) or by clearing the TEIE bit to 0.</p> <p>0: Transmit end interrupt request (TEI) is disabled 1: Transmit end interrupt request (TEI) is enabled</p>
1, 0	CKE[1:0]	00	R/W	<p>Clock Enable 1 and 0</p> <p>Select the SCI clock source and enable or disable clock output from the SCK pin. Depending on the combination of CKE1 and CKE0, the SCK pin can be used for serial clock output or serial clock input.</p> <p>When selecting the clock output in clock synchronous mode, set the C/\bar{A} bit in SCSMR to 1 and then set bits CKE1 and CKE0. For details on clock source selection, refer to table 14.14.</p> <ul style="list-style-type: none"> Asynchronous mode <ul style="list-style-type: none"> 00: Internal clock, SCK pin used for input pin (The input signal is ignored.) 01: Internal clock, SCK pin used for clock output*¹ 10: External clock, SCK pin used for clock input*² 11: External clock, SCK pin used for clock input*² Clock synchronous mode <ul style="list-style-type: none"> 00: Internal clock, SCK pin used for synchronous clock output 01: Internal clock, SCK pin used for synchronous clock output 10: External clock, SCK pin used for synchronous clock input 11: External clock, SCK pin used for synchronous clock input <p>Notes: 1. The output clock frequency is 16 times the bit rate. 2. The input clock frequency is 16 times the bit rate.</p>

14.3.7 Serial Status Register (SCSSR)

SCSSR is an 8-bit register that contains status flags to indicate the SCI operating state.

The CPU can always read and write to SCSSR, but cannot write 1 to status flags TDRE, RDRF, ORER, PER, and FER. These flags can be cleared to 0 only after 1 is read from the flags. The TEND flag is a read-only bit and cannot be modified.

Bit:	7	6	5	4	3	2	1	0
	TDRE	RDRF	ORER	FER	PER	TEND	MPB	MPBT
Initial value:	1	0	0	0	0	1	0	0
	R/W: R/(W)*	R/(W)*	R/(W)*	R/(W)*	R/(W)*	R	R	R/W

Note: * Writing 0 to this bit after reading it as 1 clears the flag and is the only allowed way.

Bit	Bit Name	Initial value	R/W	Description
7	TDRE	1	R/(W)*	<p>Transmit Data Register Empty</p> <p>Indicates whether data has been transferred from the transmit data register (SCTDR) to the transmit shift register (SCTSR) and SCTDR has become ready to be written with next serial transmit data.</p> <p>0: Indicates that SCTDR holds valid transmit data [Clearing conditions]</p> <ul style="list-style-type: none"> When 0 is written to TDRE after reading TDRE = 1 When the DTC is activated by a TXI interrupt and transmit data is transferred to SCTDR while the DISEL bit of MRB in the DTC is 0 <p>1: Indicates that SCTDR does not hold valid transmit data [Setting conditions]</p> <ul style="list-style-type: none"> By a power-on reset or in standby mode When the TE bit in SCSCR is 0 When data is transferred from SCTDR to SCTSR and data can be written to SCTDR

Bit	Bit Name	Initial value	R/W	Description
6	RDRF	0	R/(W)*	<p>Receive Data Register Full</p> <p>Indicates that the received data is stored in the receive data register (SCRDR).</p> <p>0: Indicates that valid received data is not stored in SCRDR</p> <p>[Clearing conditions]</p> <ul style="list-style-type: none"> • By a power-on reset or in standby mode • When 0 is written to RDRF after reading RDRF = 1 • When the DTC is activated by an RXI interrupt and data is transferred from SCRDR while the DISEL bit of MRB in the DTC is 0 <p>1: Indicates that valid received data is stored in SCRDR</p> <p>[Setting condition]</p> <ul style="list-style-type: none"> • When serial reception ends normally and receive data is transferred from SCRSR to SCRDR <p>Note: SCRDR and the RDRF flag are not affected and retain their previous states even if an error is detected during data reception or if the RE bit in the serial control register (SCSCR) is cleared to 0. If reception of the next data is completed while the RDRF flag is still set to 1, an overrun error will occur and the received data will be lost.</p>

Bit	Bit Name	Initial value	R/W	Description
5	ORER	0	R/(W)*	<p>Overrun Error</p> <p>Indicates that an overrun error occurred during reception, causing abnormal termination.</p> <p>0: Indicates that reception is in progress or was completed successfully*¹</p> <p>[Clearing conditions]</p> <ul style="list-style-type: none"> • By a power-on reset or in standby mode • When 0 is written to ORER after reading ORER = 1 <p>1: Indicates that an overrun error occurred during reception*²</p> <p>[Setting condition]</p> <ul style="list-style-type: none"> • When the next serial reception is completed while RDRF = 1 <p>Notes: 1. The ORER flag is not affected and retains its previous value when the RE bit in SCSCR is cleared to 0.</p> <p>2. The receive data prior to the overrun error is retained in SCRDR, and the data received subsequently is lost. Subsequent serial reception cannot be continued while the ORER flag is set to 1.</p>

Bit	Bit Name	Initial value	R/W	Description
4	FER	0	R/(W)*	<p>Framing Error</p> <p>Indicates that a framing error occurred during data reception in asynchronous mode, causing abnormal termination.</p> <p>0: Indicates that reception is in progress or was completed successfully*¹</p> <p>[Clearing conditions]</p> <ul style="list-style-type: none"> • By a power-on reset or in standby mode • When 0 is written to FER after reading FER = 1 <p>1: Indicates that a framing error occurred during reception</p> <p>[Setting condition]</p> <ul style="list-style-type: none"> • When the SCI finds that the stop bit at the end of the received data is 0 after completing reception*² <p>Notes: 1. The FER flag is not affected and retains its previous value when the RE bit in SCSCR is cleared to 0.</p> <p>2. In 2-stop-bit mode, only the first stop bit is checked for a value to 1; the second stop bit is not checked. If a framing error occurs, the receive data is transferred to SCRDR but the RDRF flag is not set. Subsequent serial reception cannot be continued while the FER flag is set to 1.</p>

Bit	Bit Name	Initial value	R/W	Description
3	PER	0	R/(W)*	<p>Parity Error</p> <p>Indicates that a parity error occurred during data reception in asynchronous mode, causing abnormal termination.</p> <p>0: Indicates that reception is in progress or was completed successfully*¹</p> <p>[Clearing conditions]</p> <ul style="list-style-type: none"> • By a power-on reset or in standby mode • When 0 is written to PER after reading PER = 1 <p>1: Indicates that a parity error occurred during reception*²</p> <p>[Setting condition]</p> <ul style="list-style-type: none"> • When the number of 1s in the received data and parity does not match the even or odd parity specified by the O/\bar{E} bit in the serial mode register (SCSMR). <p>Notes: 1. The PER flag is not affected and retains its previous value when the RE bit in SCSCR is cleared to 0.</p> <p>2. If a parity error occurs, the receive data is transferred to SCRDR but the RDRF flag is not set. Subsequent serial reception cannot be continued while the PER flag is set to 1.</p>

Bit	Bit Name	Initial value	R/W	Description
2	TEND	1	R	<p>Transmit End</p> <p>Indicates that no valid data was in SCTDR during transmission of the last bit of the transmit character and transmission has ended.</p> <p>The TEND flag is read-only and cannot be modified.</p> <p>0: Indicates that transmission is in progress [Clearing condition]</p> <ul style="list-style-type: none"> When 0 is written to TDRE after reading TDRE = 1 <p>1: Indicates that transmission has ended [Setting conditions]</p> <ul style="list-style-type: none"> By a power-on reset or in standby mode When the TE bit in SCSCR is 0 When TDRE = 1 during transmission of the last bit of a 1-byte serial transmit character <p>Note: The TEND flag value becomes undefined if data is written to SCTDR by activating the DTC by a TXI interrupt. In this case, do not use the TEND flag as the transmit end flag.</p>
1	MPB	0	R	<p>Multiprocessor Bit</p> <p>Stores the multiprocessor bit found in the receive data. When the RE bit in SCSCR is cleared to 0, its previous state is retained.</p>
0	MPBT	0	R/W	<p>Multiprocessor Bit Transfer</p> <p>Specifies the multiprocessor bit value to be added to the transmit frame.</p>

Note: * Writing 0 to this bit after reading it as 1 clears the flag and is the only allowed way.

14.3.8 Serial Port Register (SCSPTR)

SCSPTR is an 8-bit register that controls input/output and data for the ports multiplexed with the SCI function pins. Data to be output through the TXD pin can be specified to control break of serial transfer. Through bits 3 and 2, data reading and writing through the SCK pin can be specified. Bit 7 enables or disables RXI interrupts. The CPU can always read and write to SCSPTR. When reading the value on the SCI pins, use the respective port register. For details, refer to section 18, I/O Ports.

Bit:	7	6	5	4	3	2	1	0
	EIO	-	-	-	SPB1IO	SPB1DT	SPB0IO	SPB0DT
Initial value:	0	0	0	0	0	-	0	1
R/W:	R/W	-	-	-	R/W	R/W	R/W	R/W

Bit	Bit Name	Initial value	R/W	Description
7	EIO	0	R/W	Error Interrupt Only Enables or disables RXI interrupts. While the EIO bit is set to 1, the SCI does not request an RXI interrupt to the CPU even if the RIE bit is set to 1. 0: The RIE bit enables or disables RXI and ERI interrupts. While the RIE bit is 1, RXI and ERI interrupts are sent to the INTC. 1: While the RIE bit is 1, only the ERI interrupt is sent to the INTC.
6 to 4	—	All 0	—	Reserved These bits are always read as 0. The write value should always be 0.
3	SPB1IO	0	R/W	Clock Port Input/Output in Serial Port Specifies the input/output direction of the SCK pin in the serial port. To output the data specified in the SPB1DT bit through the SCK pin as a port output pin, set the C/ \bar{A} bit in SCSMR and the CKE1 and CKE0 bits in SCSCR to 0. 0: Does not output the SPB1DT bit value through the SCK pin. 1: Outputs the SPB1DT bit value through the SCK pin.

Bit	Bit Name	Initial value	R/W	Description																				
2	SPB1DT	Undefined	R/W	<p>Clock Port Data in Serial Port</p> <p>Specifies the data output through the SCK pin in the serial port. Output should be enabled by the SPB1IO bit (for details, refer to the SPB1IO bit description). When output is enabled, the SPB1DT bit value is output through the SCK pin.</p> <p>0: Low level is output 1: High level is output</p>																				
1	SPB0IO	0	R/W	<p>Serial Port Break Output</p> <p>Together with the SPB0DT bit and the TE bit in SCSCR, controls the TXD pin.</p>																				
0	SPB0DT	1	R/W	<p>Serial Port Break Data</p> <p>Together with the SPB0IO bit and TE bit in SCSCR, controls the TXD pin. Note that the TXD pin function needs to have been selected with the pin function controller (PFC).</p> <table border="1"> <thead> <tr> <th>TE bit setting in SCSCR</th> <th>SPB0IO bit setting</th> <th>SPB0DT bit setting</th> <th>State of TXD pin</th> </tr> </thead> <tbody> <tr> <td>0</td> <td>0</td> <td>*</td> <td>SPB0DT output disabled (initial state)</td> </tr> <tr> <td>0</td> <td>1</td> <td>0</td> <td>Output, low level</td> </tr> <tr> <td>0</td> <td>1</td> <td>1</td> <td>Output, high level</td> </tr> <tr> <td>1</td> <td>*</td> <td>*</td> <td>Output for transmit data in accord with the serial core logic</td> </tr> </tbody> </table> <p>Note: * Don't care</p>	TE bit setting in SCSCR	SPB0IO bit setting	SPB0DT bit setting	State of TXD pin	0	0	*	SPB0DT output disabled (initial state)	0	1	0	Output, low level	0	1	1	Output, high level	1	*	*	Output for transmit data in accord with the serial core logic
TE bit setting in SCSCR	SPB0IO bit setting	SPB0DT bit setting	State of TXD pin																					
0	0	*	SPB0DT output disabled (initial state)																					
0	1	0	Output, low level																					
0	1	1	Output, high level																					
1	*	*	Output for transmit data in accord with the serial core logic																					

14.3.9 Serial Direction Control Register (SCSDCR)

The DIR bit in the serial direction control register (SCSDCR) selects LSB-first or MSB-first transfer. With an 8-bit data length, LSB-first/MSB-first selection is available regardless of the communication mode.

Bit:	7	6	5	4	3	2	1	0
	-	-	-	-	DIR	-	-	-
Initial value:	1	1	1	1	0	0	1	0
R/W:	R	R	R	R	R/W	R	R	R

Bit	Bit Name	Initial Value	R/W	Description
7 to 4	—	All 1	R	Reserved These bits are always read as 1. The write value should always be 1.
3	DIR	0	R/W	Data Transfer Direction Selects the serial/parallel conversion format. Valid for an 8-bit transmit/receive format. 0: SCTDR contents are transmitted in LSB-first order Receive data is stored in SCRDR in LSB-first 1: SCTDR contents are transmitted in MSB-first order Receive data is stored in SCRDR in MSB-first
2	—	0	R	Reserved This bit is always read as 0. The write value should always be 0.
1	—	1	R	Reserved This bit is always read as 1. The write value should always be 1.
0	—	0	R	Reserved This bit is always read as 0. The write value should always be 0.

14.3.10 Bit Rate Register (SCBRR)

SCBRR is an 8-bit register that, together with the baud rate generator clock source selected by the CKS1 and CKS0 bits in the serial mode register (SCSMR), determines the serial transmit/receive bit rate.

The CPU can always read and write to SCBRR.

The SCBRR setting is calculated as follows:

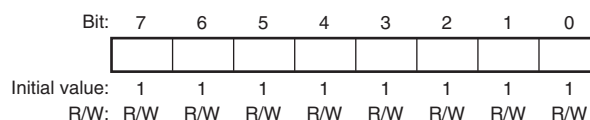

- Asynchronous mode:

$$N = \frac{P\phi}{64 \times 2^{2n-1} \times B} \times 10^6 - 1$$

- Clock synchronous mode:

$$N = \frac{P\phi}{8 \times 2^{2n-1} \times B} \times 10^6 - 1$$

B: Bit rate (bits/s)

N: SCBRR setting for baud rate generator ($0 \leq N \leq 255$)

(The setting value should satisfy the electrical characteristics.)

P ϕ : Operating frequency for peripheral modules (MHz)

n: Baud rate generator clock source (n = 0, 1, 2, 3) (for the clock sources and values of n, see table 14.3.)

Table 14.3 SCSMR Settings

n	Clock Source	SCSMR Settings	
		CKS1	CKS0
0	P ϕ	0	0
1	P ϕ /4	0	1
2	P ϕ /16	1	0
3	P ϕ /64	1	1

Note: The bit rate error in asynchronous is given by the following formula:

$$\text{Error (\%)} = \left\{ \frac{P\phi \times 10^6}{(N + 1) \times B \times 64 \times 2^{2n-1}} - 1 \right\} \times 100$$

Tables 14.4 to 14.6 show examples of SCBRR settings in asynchronous mode, and tables 14.7 to 14.9 show examples of SCBRR settings in clock synchronous mode.

Table 14.4 Bit Rates and SCBRR Settings in Asynchronous Mode (1)

Bit Rate (bits/s)	P ϕ (MHz)																	
	10			12			14			16			18			20		
	n	N	Error (%)	n	N	Error (%)	n	N	Error (%)	n	N	Error (%)	n	N	Error (%)	n	N	Error (%)
110	2	177	-0.25	2	212	0.03	2	248	-0.17	3	70	0.03	3	79	-0.12	3	88	-0.25
150	2	129	0.16	2	155	0.16	2	181	0.16	2	207	0.16	2	233	0.16	3	64	0.16
300	2	64	0.16	2	77	0.16	2	90	0.16	2	103	0.16	2	116	0.16	2	129	0.16
600	1	129	0.16	1	155	0.16	1	181	0.16	1	207	0.16	1	233	0.16	2	64	0.16
1200	1	64	0.16	1	77	0.16	1	90	0.16	1	103	0.16	1	116	0.16	1	129	0.16
2400	0	129	0.16	0	155	0.16	0	181	0.16	0	207	0.16	0	233	0.16	1	64	0.16
4800	0	64	0.16	0	77	0.16	0	90	0.16	0	103	0.16	0	116	0.16	0	129	0.16
9600	0	32	-1.36	0	38	0.16	0	45	-0.93	0	51	0.16	0	58	-0.69	0	64	0.16
14400	0	21	-1.36	0	25	0.16	0	29	1.27	0	34	-0.79	0	38	0.16	0	42	0.94
19200	0	15	1.73	0	19	-2.34	0	22	-0.93	0	25	0.16	0	28	1.02	0	32	-1.36
28800	0	10	-1.36	0	12	0.16	0	14	1.27	0	16	2.12	0	19	-2.34	0	21	-1.36
31250	0	9	0.00	0	11	0.00	0	13	0.00	0	15	0.00	0	17	0.00	0	19	0.00
38400	0	7	1.73	0	9	-2.34	0	10	3.57	0	12	0.16	0	14	-2.34	0	15	1.73

Table 14.5 Bit Rates and SCBRR Settings in Asynchronous Mode (2)

Bit Rate (bits/s)	P ϕ (MHz)																	
	22			24			26			28			30			32		
	n	N	Error (%)	n	N	Error (%)	n	N	Error (%)	n	N	Error (%)	n	N	Error (%)	n	N	Error (%)
110	3	97	-0.35	3	106	-0.44	3	114	0.36	3	123	0.23	3	132	0.13	3	141	0.03
150	3	71	-0.54	3	77	0.16	3	84	-0.43	3	90	0.16	3	97	-0.35	3	103	0.16
300	2	142	0.16	2	155	0.16	2	168	0.16	2	181	0.16	2	194	0.16	2	207	0.16
600	2	71	-0.54	2	77	0.16	2	84	-0.43	2	90	0.16	2	97	-0.35	2	103	0.16
1200	1	142	0.16	1	155	0.16	1	168	0.16	1	181	0.16	1	194	0.16	1	207	0.16
2400	1	71	-0.54	1	77	0.16	1	84	-0.43	1	90	0.16	1	97	-0.35	1	103	0.16
4800	0	142	0.16	0	155	0.16	0	168	0.16	0	181	0.16	0	194	0.16	0	207	0.16
9600	0	71	-0.54	0	77	0.16	0	84	-0.43	0	90	0.16	0	97	-0.35	0	103	0.16
14400	0	47	-0.54	0	51	0.16	0	55	0.76	0	60	-0.39	0	64	0.16	0	68	0.64
19200	0	35	-0.54	0	38	0.16	0	41	0.76	0	45	-0.93	0	48	-0.35	0	51	0.16
28800	0	23	-0.54	0	25	0.16	0	27	0.76	0	29	1.27	0	32	-1.36	0	34	-0.79
31250	0	21	0.00	0	23	0.00	0	25	0.00	0	27	0.00	0	29	0.00	0	31	0.00
38400	0	17	-0.54	0	19	-2.34	0	20	0.76	0	22	-0.93	0	23	1.73	0	25	0.16

Table 14.6 Bit Rates and SCBRR Settings in Asynchronous Mode (3)

Bit Rate (bits/s)	P ϕ (MHz)											
	34			36			38			40		
	n	N	Error (%)	n	N	Error (%)	n	N	Error (%)	n	N	Error (%)
110	3	150	-0.05	3	159	-0.12	3	168	-0.19	3	177	-0.25
150	3	110	-0.29	3	116	0.16	3	123	-0.24	3	129	0.16
300	2	220	0.16	2	233	0.16	2	246	0.16	3	64	0.16
600	2	110	-0.29	2	116	0.16	2	123	-0.24	2	129	0.16
1200	1	220	0.16	1	233	0.16	1	246	0.16	2	64	0.16
2400	1	110	-0.29	1	116	0.16	1	123	-0.24	1	129	0.16
4800	0	220	0.16	0	233	0.16	0	246	0.16	1	64	0.16
9600	0	110	-0.29	0	116	0.16	0	123	-0.24	0	129	0.16
14400	0	73	-0.29	0	77	0.16	0	81	0.57	0	86	-0.22
19200	0	54	0.62	0	58	-0.69	0	61	-0.24	0	64	0.16
28800	0	36	-0.29	0	38	0.16	0	40	0.57	0	42	0.94
31250	0	33	0.00	0	35	0.00	0	37	0.00	0	39	0.00
38400	0	27	-1.18	0	28	1.02	0	30	-0.24	0	32	-1.36

Table 14.7 Bit Rates and SCBRR Settings in Clock Synchronous Mode (1)

Bit Rate (bits/s)	P ϕ (MHz)											
	10		12		14		16		18		20	
	n	N	n	N	n	N	n	N	n	N	n	N
250	3	155	3	187	3	218	3	249				
500	3	77	3	93	3	108	3	124	3	140	3	155
1000	2	155	2	187	2	218	2	249	3	69	3	77
2500	1	249	2	74	2	87	2	99	2	112	2	124
5000	1	124	1	149	1	174	1	199	1	224	1	249
10000	0	249	1	74	1	87	1	99	1	112	1	124
25000	0	99	0	119	0	139	0	159	0	179	0	199
50000	0	49	0	59	0	69	0	79	0	89	0	99
100000	0	24	0	29	0	34	0	39	0	44	0	49
250000	0	9	0	11	0	13	0	15	0	17	0	19
500000	0	4	0	5	0	6	0	7	0	8	0	9
1000000	—	—	0	2	—	—	0	3	—	—	0	4
2500000	0	0*	—	—	—	—	—	—	—	—	0	1
5000000			—	—	—	—	—	—	—	—	0	0*

Table 14.8 Bit Rates and SCBRR Settings in Clock Synchronous Mode (2)

Bit Rate (bits/s)	P_{ϕ} (MHz)											
	22		24		26		28		30		32	
	n	N	n	N	n	N	n	N	n	N	n	N
250												
500	3	171	3	187	3	202	3	218	3	233	3	249
1000	3	85	3	93	3	101	3	108	3	116	3	124
2500	2	137	2	149	2	162	2	174	2	187	2	199
5000	2	68	2	74	2	80	2	87	2	93	2	99
10000	1	137	1	149	1	162	1	174	1	187	1	199
25000	0	219	0	239	1	64	1	69	1	74	1	79
50000	0	109	0	119	0	129	0	139	0	149	0	159
100000	0	54	0	59	0	64	0	69	0	74	0	79
250000	0	21	0	23	0	25	0	27	0	29	0	31
500000	0	10	0	11	0	12	0	13	0	14	0	15
1000000	—	—	0	5	—	—	0	6	—	—	0	7
2500000	—	—	—	—	—	—	—	—	0	2	—	—
5000000	—	—	—	—	—	—	—	—	—	—	—	—

Table 14.9 Bit Rates and SCBRR Settings in Clock Synchronous Mode (3)

Bit Rate (bits/s)	P ϕ (MHz)							
	34		36		38		40	
	n	N	n	N	n	N	n	N
250								
500								
1000	3	132	3	140	3	147	3	155
2500	2	212	2	224	2	237	2	249
5000	2	105	2	112	2	118	2	124
10000	1	212	1	224	1	237	1	249
25000	1	84	1	89	1	94	1	99
50000	0	169	0	179	0	189	0	199
100000	0	84	0	89	0	94	0	99
250000	0	33	0	35	0	37	0	39
500000	0	16	0	17	0	18	0	19
1000000	—	—	0	8	—	—	0	9
2500000	—	—	—	—	—	—	0	3
5000000	—	—	—	—	—	—	0	1

[Legend]

Blank: No setting possible

—: Setting possible, but error occurs

*: Continuous transmission/reception is disabled.

Note: Settings with an error of 1% or less are recommended.

Table 14.10 indicates the maximum bit rates in asynchronous mode when the baud rate generator is used. Tables 14.11 and 14.12 list the maximum rates for external clock input.

Table 14.10 Maximum Bit Rates for Various Frequencies with Baud Rate Generator (Asynchronous Mode)

P ϕ (MHz)	Maximum Bit Rate (bits/s)	Settings	
		n	N
10	312500	0	0
12	375000	0	0
14	437500	0	0
16	500000	0	0
18	562500	0	0
20	625000	0	0
22	687500	0	0
24	750000	0	0
26	812500	0	0
28	875000	0	0
30	937500	0	0
32	1000000	0	0
34	1062500	0	0
36	1125000	0	0
38	1187500	0	0
40	1250000	0	0

Table 14.11 Maximum Bit Rates with External Clock Input (Asynchronous Mode)

Pϕ (MHz)	External Input Clock (MHz)	Maximum Bit Rate (bits/s)
10	2.5000	156250
12	3.0000	187500
14	3.5000	218750
16	4.0000	250000
18	4.5000	281250
20	5.0000	312500
22	5.5000	343750
24	6.0000	375000
26	6.5000	406250
28	7.0000	437500
30	7.5000	468750
32	8.0000	500000
34	8.5000	531250
36	9.0000	562500
38	9.5000	593750
40	10.0000	625000

Table 14.12 Maximum Bit Rates with External Clock Input (Clock Synchronous Mode)

Pϕ (MHz)	External Input Clock (MHz)	Maximum Bit Rate (bits/s)
10	1.6667	1666666.7
12	2.0000	2000000.0
14	2.3333	2333333.3
16	2.6667	2666666.7
18	3.0000	3000000.0
20	3.3333	3333333.3
22	3.6667	3666666.7
24	4.0000	4000000.0
26	4.3333	4333333.3
28	4.6667	4666666.7
30	5.0000	5000000.0
32	5.3333	5333333.3
34	5.6667	5666666.7
36	6.0000	6000000.0
38	6.3333	6333333.3
40	6.6667	6666666.7

14.4 Operation

14.4.1 Overview

For serial communication, the SCI has an asynchronous mode in which characters are synchronized individually, and a clock synchronous mode in which communication is synchronized with clock pulses.

Asynchronous or clock synchronous mode is selected and the transmit format is specified in the serial mode register (SCSMR) as shown in table 14.13. The SCI clock source is selected by the combination of the $\overline{C/A}$ bit in SCSMR and the CKE1 and CKE0 bits in the serial control register (SCSCR) as shown in table 14.14.

(1) Asynchronous Mode

- Data length is selectable: 7 or 8 bits.
- Parity bit is selectable. So is the stop bit length (1 or 2 bits). The combination of the preceding selections constitutes the communication format and character length.
- In receiving, it is possible to detect framing errors, parity errors, overrun errors, and breaks.
- An internal or external clock can be selected as the SCI clock source.
 - When an internal clock is selected, the SCI operates using the clock supplied by the on-chip baud rate generator and can output a clock with a frequency 16 times the bit rate.
 - When an external clock is selected, the external clock input must have a frequency 16 times the bit rate. (The on-chip baud rate generator is not used.)

(2) Clock Synchronous Mode

- The transmission/reception format has a fixed 8-bit data length.
- In receiving, it is possible to detect overrun errors.
- An internal or external clock can be selected as the SCI clock source.
 - When an internal clock is selected, the SCI operates using the on-chip baud rate generator, and outputs a serial clock signal to external devices.
 - When an external clock is selected, the SCI operates on the input serial clock. The on-chip baud rate generator is not used.

Table 14.13 SCSMR Settings and SCI Communication Formats

SCSMR Settings				SCI Communication Format					
Bit 7 C/ \bar{A}	Bit 6 CHR	Bit 5 PE	Bit 3 STOP	Mode	Data Length	Parity Bit	Stop Bit Length		
0	0	0	0	Asynchronous	8-bit	Not set	1 bit		
			1				2 bits		
		1	0			Set	1 bit		
			1				2 bits		
		1	0			0	7-bit	Not set	1 bit
						1			2 bits
1	1	0	Set	1 bit					
		1		2 bits					
1	x	x	x	Clock synchronous	8-bit	Not set		None	

[Legend]

x: Don't care

Table 14.14 SCSMR and SCSCR Settings and SCI Clock Source Selection

SCSMR			SCSCR Settings		Clock Source	SCK Pin Function	
Bit 7 C/ \bar{A}	Bit 1 CKE1	Bit 0 CKE0	Mode	Mode			
0	0	0	Asynchronous	Internal	SCI does not use the SCK pin.		
		1			Clock with a frequency 16 times the bit rate is output.		
		1			0	External	Input a clock with frequency 16 times the bit rate.
					1		
1	0	0	Clock synchronous	Internal	Serial clock is output.		
		1			External	Input the serial clock.	
		1					0
							1

14.4.2 Operation in Asynchronous Mode

In asynchronous mode, each transmitted or received character begins with a start bit and ends with a stop bit. Serial communication is synchronized one character at a time.

The transmitting and receiving sections of the SCI are independent, so full duplex communication is possible. Both the transmitter and receiver have a double-buffered structure so that data can be read or written during transmission or reception, enabling continuous data transfer.

Figure 14.2 shows the general format of asynchronous serial communication. In asynchronous serial communication, the communication line is normally held in the mark (high) state. The SCI monitors the line and starts serial communication when the line goes to the space (low) state, indicating a start bit. One serial character consists of a start bit (low), data (LSB first), parity bit (high or low), and stop bit (high), in that order.

When receiving in asynchronous mode, the SCI synchronizes at the falling edge of the start bit. The SCI samples each data bit on the eighth pulse of a clock with a frequency 16 times the bit rate. Receive data is latched at the center of each bit.

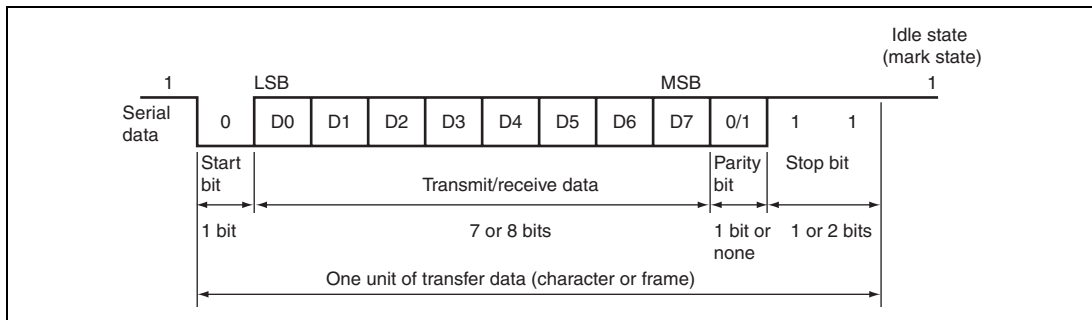

**Figure 14.2 Example of Data Format in Asynchronous Communication
(8-Bit Data with Parity and Two Stop Bits)**

(1) Transmit/Receive Formats

Table 14.15 shows the transfer formats that can be selected in asynchronous mode. Any of 12 transfer formats can be selected according to the SCSMR settings.

Table 14.15 Serial Transfer Formats (Asynchronous Mode)

SCSMR Settings				Serial Transfer Format and Frame Length													
CHR	PE	MP	STOP	1	2	3	4	5	6	7	8	9	10	11	12		
0	0	0	0	S	8-bit data								STOP				
0	0	0	1	S	8-bit data								STOP	STOP			
0	1	0	0	S	8-bit data								P	STOP			
0	1	0	1	S	8-bit data								P	STOP	STOP		
1	0	0	0	S	7-bit data							STOP					
1	0	0	1	S	7-bit data							STOP	STOP				
1	1	0	0	S	7-bit data							P	STOP				
1	1	0	1	S	7-bit data							P	STOP	STOP			
0	x	1	0	S	8-bit data								MPB	STOP			
0	x	1	1	S	8-bit data								MPB	STOP	STOP		
1	x	1	0	S	7-bit data							MPB	STOP				
1	x	1	1	S	7-bit data							MPB	STOP	STOP			

[Legend]

S: Start bit

STOP: Stop bit

P: Parity bit

MPB: Multiprocessor bit

x: Don't care

(2) Clock

An internal clock generated by the on-chip baud rate generator or an external clock input from the SCK pin can be selected as the SCI transmit/receive clock. The clock source is selected by the $\overline{C/A}$ bit in the serial mode register (SCSMR) and bits CKE1 and CKE0 in the serial control register (SCSCR) (table 14.14).

When an external clock is input at the SCK pin, it must have a frequency equal to 16 times the desired bit rate.

When the SCI operates on an internal clock, it can output a clock signal at the SCK pin. The frequency of this output clock is equal to 16 times the desired bit rate.

(3) Transmitting and Receiving Data

SCI Initialization (Asynchronous Mode):

Before transmitting or receiving, clear the TE and RE bits to 0 in the serial control register (SCSCR), then initialize the SCI as follows.

When changing the operation mode or the communication format, always clear the TE and RE bits to 0 before following the procedure given below. Clearing the TE bit to 0 sets the TDRE flag to 1 and initializes the transmit shift register (SCTSR). Clearing the RE bit to 0, however, does not initialize the RDRF, PER, FER, and ORER flags or receive data register (SCRDR), which retain their previous contents.

When an external clock is used, the clock should not be stopped during initialization or subsequent operation. SCI operation becomes unreliable if the clock is stopped.

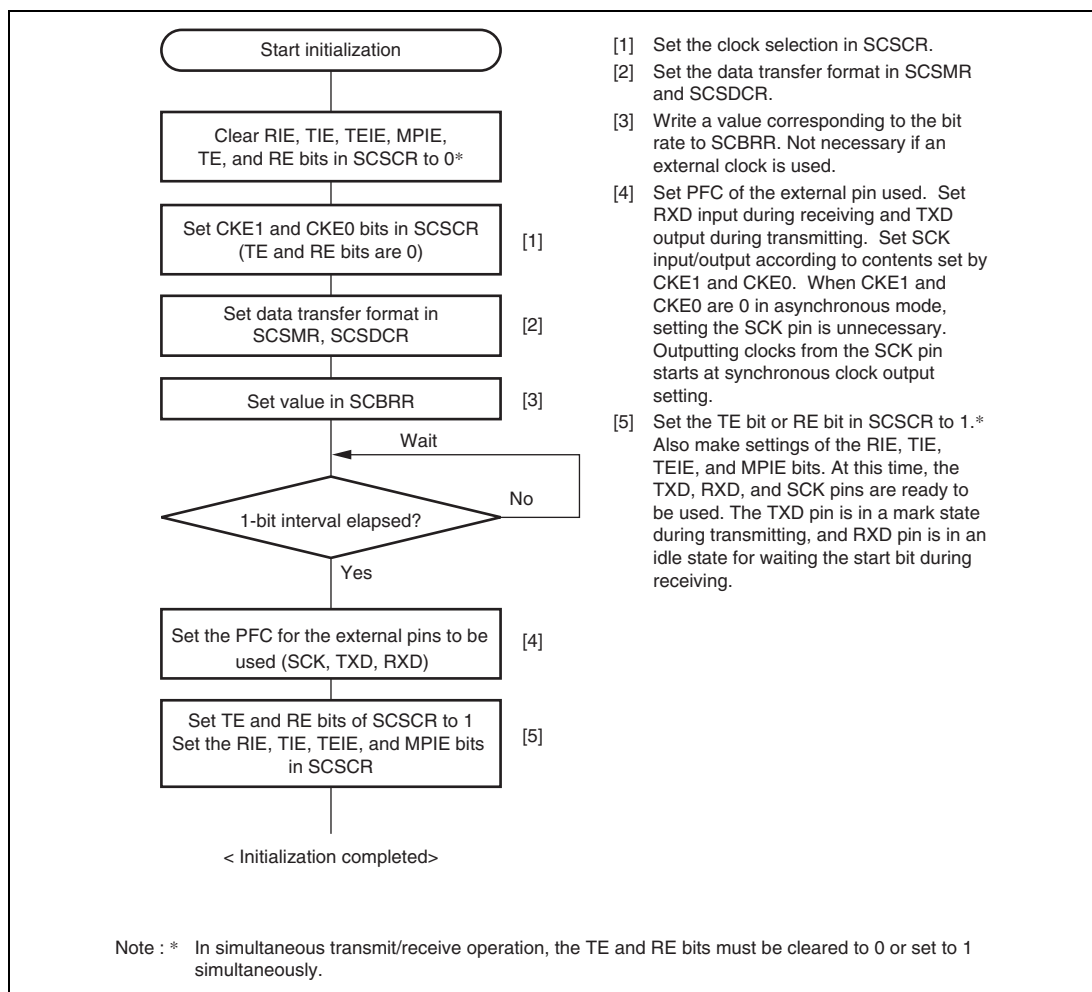

Figure 14.3 Sample Flowchart for SCI Initialization

Transmitting Serial Data (Asynchronous Mode):

Figure 14.4 shows a sample flowchart for serial transmission.

Use the following procedure for serial data transmission after enabling the SCI for transmission.

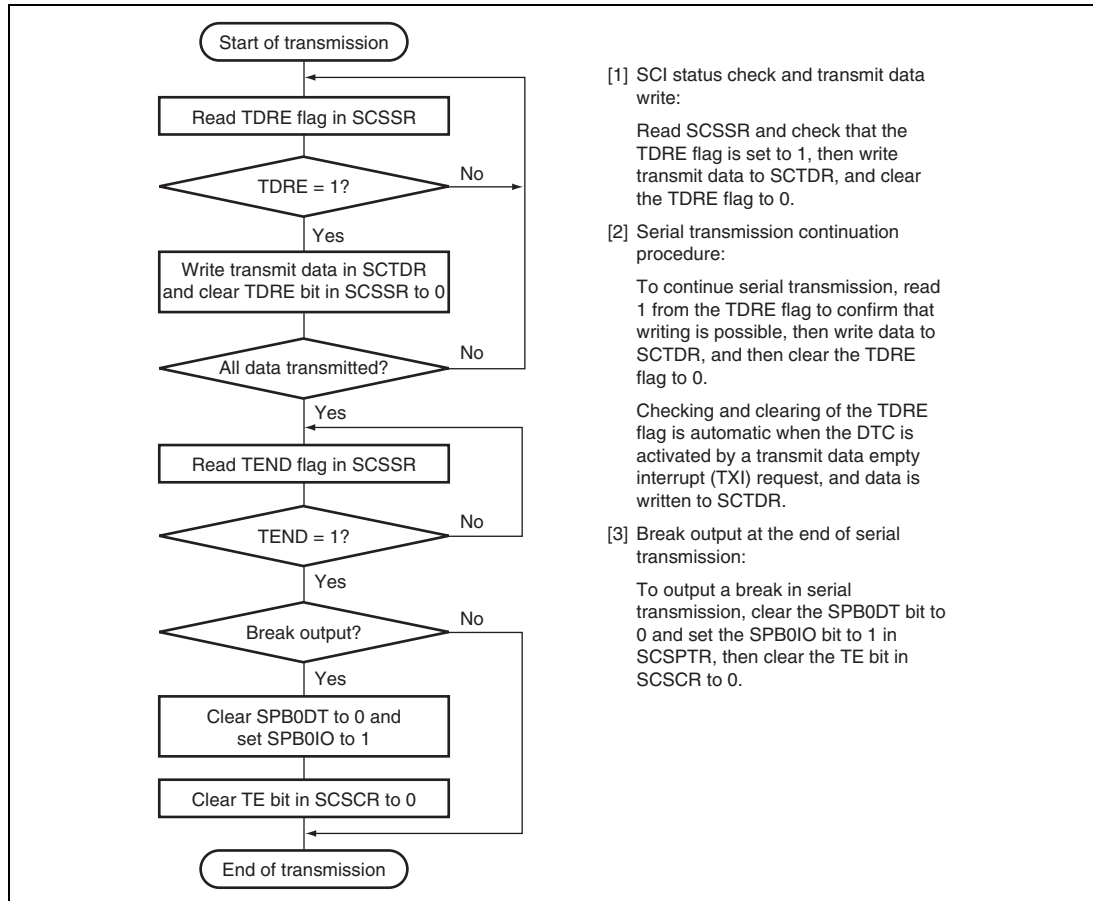

Figure 14.4 Sample Flowchart for Transmitting Serial Data

In serial transmission, the SCI operates as described below.

1. The SCI monitors the TDRE flag in the serial status register (SCSSR). If it is cleared to 0, the SCI recognizes that data has been written to the transmit data register (SCTDR) and transfers the data from SCTDR to the transmit shift register (SCTSR).
2. After transferring data from SCTDR to SCTSR, the SCI sets the TDRE flag to 1 and starts transmission. If the TIE bit in the serial control register (SCSCR) is set to 1 at this time, a transmit-data-empty interrupt (TXI) request is generated.

The serial transmit data is sent from the TXD pin in the following order.

- A. Start bit: One-bit 0 is output.
 - B. Transmit data: 8-bit or 7-bit data is output in LSB-first order.
 - C. Parity bit or multiprocessor bit: One parity bit (even or odd parity) or one multiprocessor bit is output. (A format in which neither parity nor multiprocessor bit is output can also be selected.)
 - D. Stop bit(s): One or two 1 bits (stop bits) are output.
 - E. Mark state: 1 is output continuously until the start bit that starts the next transmission is sent.
3. The SCI checks the TDRE flag at the timing for sending the stop bit.
If the TDRE flag is 0, the data is transferred from SCTDR to SCTSR, the stop bit is sent, and then serial transmission of the next frame is started.
If the TDRE flag is 1, the TEND flag in SCSSR is set to 1, the stop bit is sent, and then the "mark state" is entered in which 1 is output. If the TEIE bit in SCSCR is set to 1 at this time, a TEI interrupt request is generated.

Figure 14.5 shows an example of the operation for transmission.

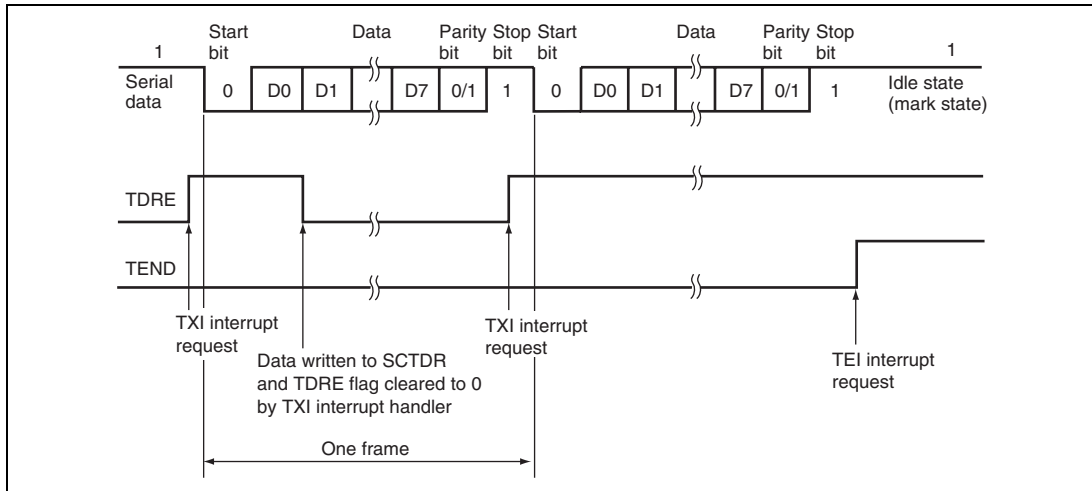

Figure 14.5 Example of Transmission in Asynchronous Mode (8-Bit Data, Parity, One Stop Bit)

Receiving Serial Data (Asynchronous Mode):

Figure 14.6 shows a sample flowchart for serial reception.

Use the following procedure for serial data reception after enabling the SCI for reception.

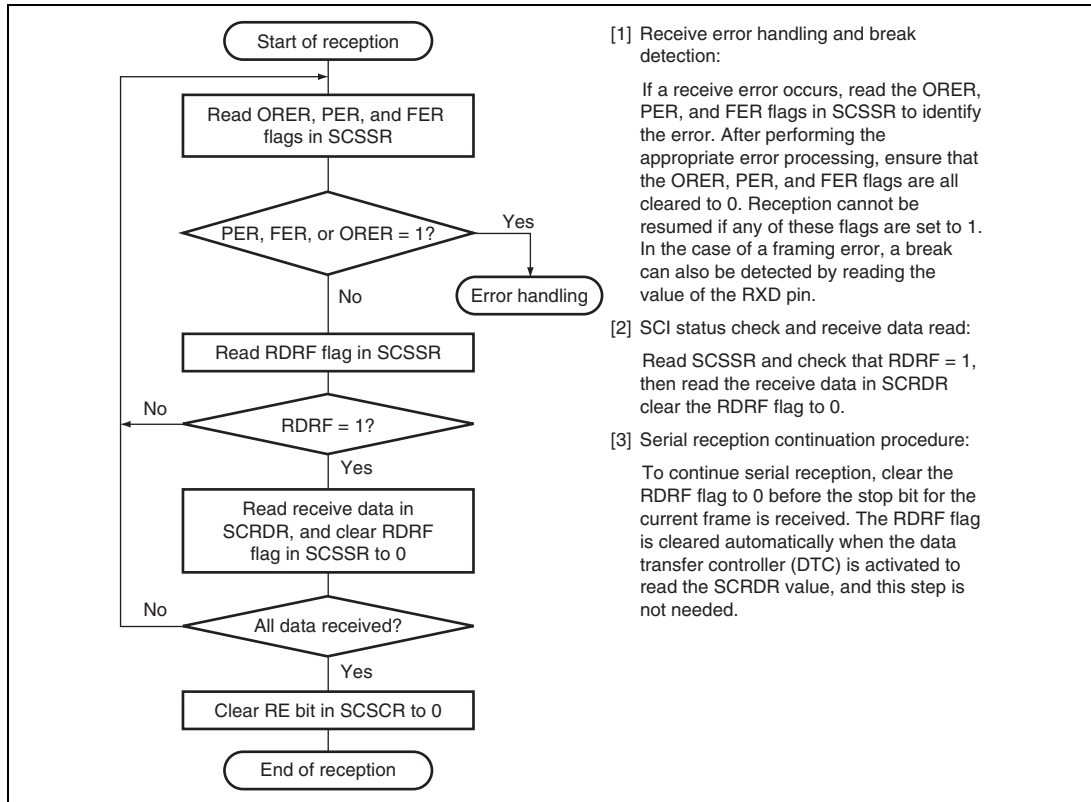
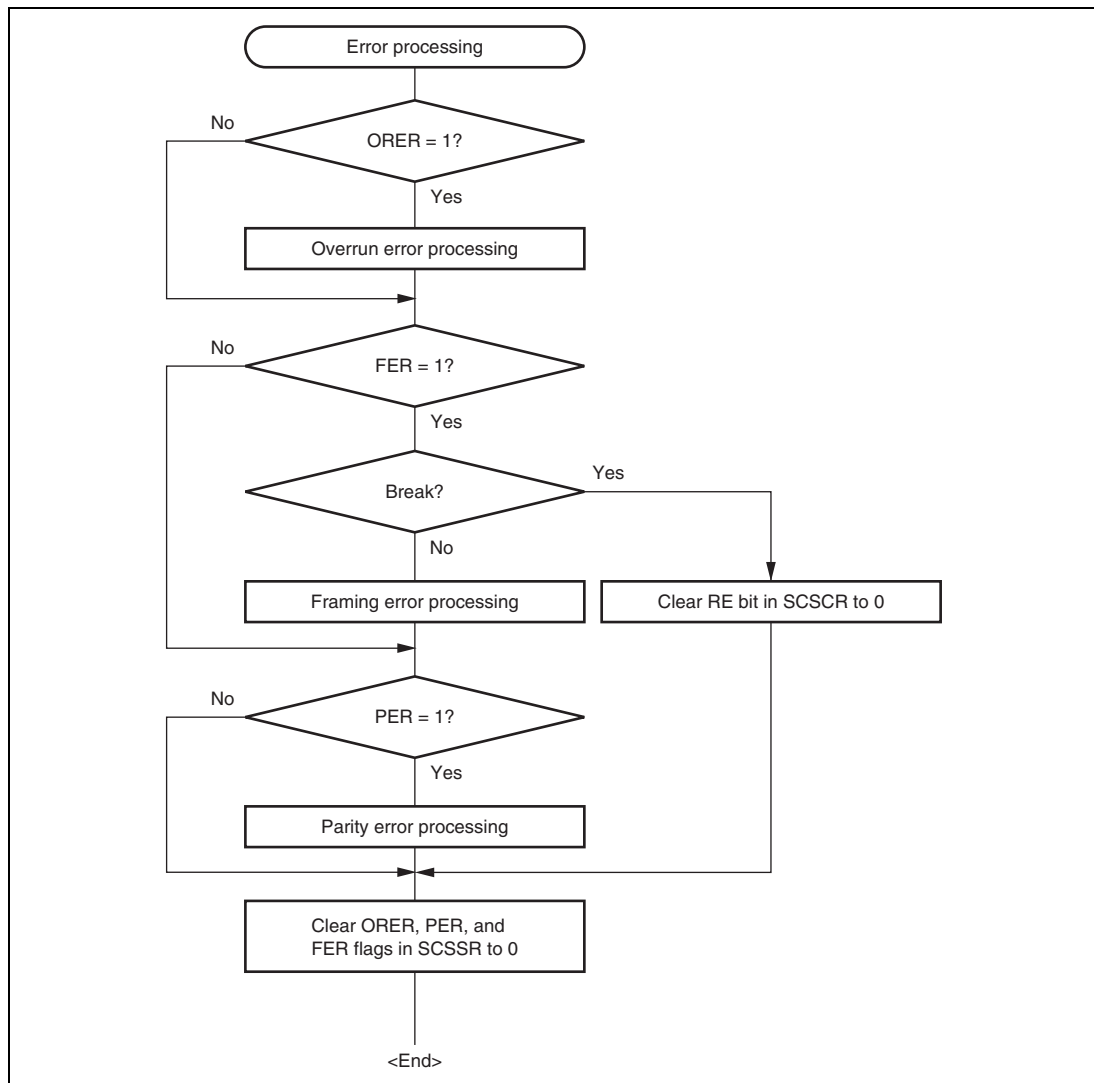

Figure 14.6 Sample Flowchart for Receiving Serial Data (1)

**Figure 14.6 Sample Flowchart for Receiving Serial Data (2)**

In serial reception, the SCI operates as described below.

1. The SCI monitors the transmission line, and if a 0 start bit is detected, performs internal synchronization and starts reception.
2. The received data is stored in SCRSR in LSB-to-MSB order.
3. The parity bit and stop bit are received.
After receiving these bits, the SCI carries out the following checks.
 - A. Parity check: The SCI counts the number of 1s in the received data and checks whether the count matches the even or odd parity specified by the O/\bar{E} bit in the serial mode register (SCSMR).
 - B. Stop bit check: The SCI checks whether the stop bit is 1. If there are two stop bits, only the first is checked.
 - C. Status check: The SCI checks whether the RDRF flag is 0 and the received data can be transferred from the receive shift register (SCRSR) to SCRDR.

If all the above checks are passed, the RDRF flag is set to 1 and the received data is stored in SCRDR. If a receive error is detected, the SCI operates as shown in table 14.16

Note: When a receive error occurs, subsequent reception cannot be continued. In addition, the RDRF flag will not be set to 1 after reception; be sure to clear the error flag to 0.

4. If the EIO bit in SCSPTR is cleared to 0 and the RIE bit in SCSCR is set to 1 when the RDRF flag changes to 1, a receive-data-full interrupt (RXI) request is generated. If the RIE bit in SCSCR is set to 1 when the ORER, PER, or FER flag changes to 1, a receive error interrupt (ERI) request is generated.

Table 14.16 Receive Errors and Error Conditions

Receive Error	Abbreviation	Error Condition	Data Transfer
Overrun error	ORER	When the next data reception is completed while the RDRF flag in SCSSR is set to 1	The received data is not transferred from SCRSR to SCRDR.
Framing error	FER	When the stop bit is 0	The received data is transferred from SCRSR to SCRDR.
Parity error	PER	When the received data does not match the even or odd parity specified in SCSMR	The received data is transferred from SCRSR to SCRDR.

Figure 14.7 shows an example of the operation for reception.

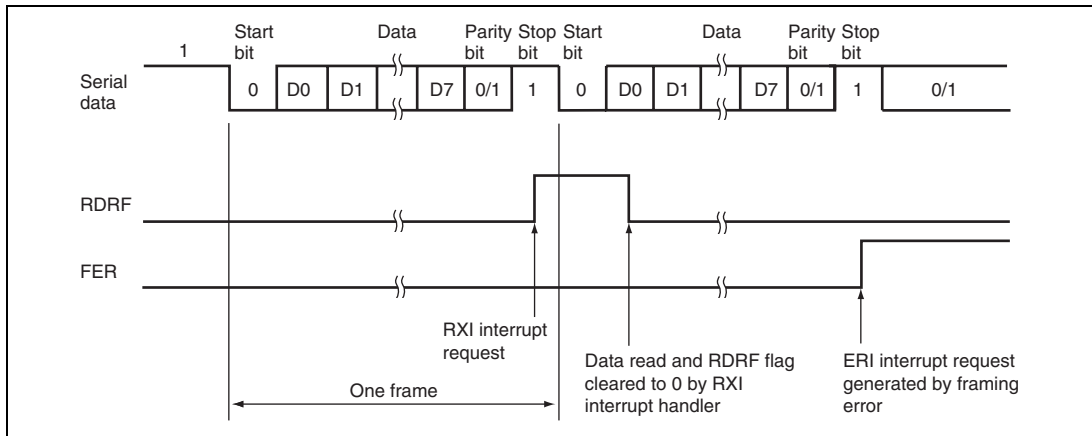

Figure 14.7 Example of SCI Receive Operation (8-Bit Data, Parity, One Stop Bit)

14.4.3 Clock Synchronous Mode

In clock synchronous mode, the SCIF transmits and receives data in synchronization with clock pulses. This mode is suitable for high-speed serial communication.

The SCI transmitter and receiver are independent, so full-duplex communication is possible while sharing the same clock. Both the transmitter and receiver have a double-buffered structure so that data can be read or written during transmission or reception, enabling continuous data transfer.

Figure 14.8 shows the general format in clock synchronous serial communication.

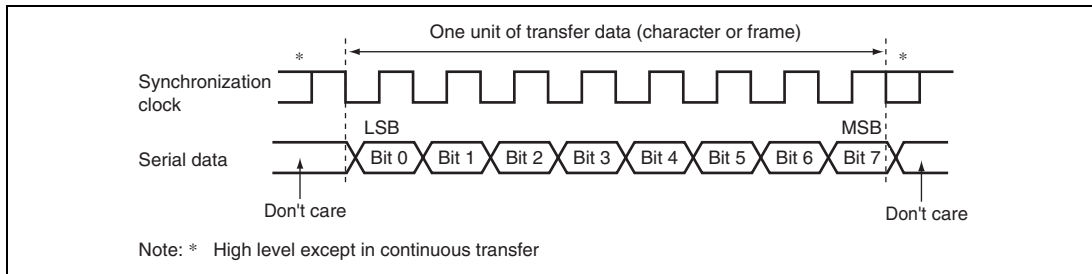

Figure 14.8 Data Format in Clock Synchronous Communication

In clock synchronous serial communication, each data bit is output on the communication line from one falling edge of the serial clock to the next. Data is guaranteed valid at the rising edge of the serial clock. In each character, the serial data bits are transmitted in order from the LSB (first) to the MSB (last). After output of the MSB, the communication line remains in the state of the MSB. In clock synchronous mode, the SCI transmits or receives data by synchronizing with the rising edge of the serial clock.

(1) Communication Format

The data length is fixed at eight bits. No parity bit can be added.

(2) Clock

An internal clock generated by the on-chip baud rate generator or an external clock input from the SCK pin can be selected as the SCI transmit/receive clock. For selection of the SCI clock source, see table 14.14.

When the SCI operates on an internal clock, it outputs the clock signal at the SCK pin. Eight clock pulses are output per transmitted or received character. When the SCI is not transmitting or receiving, the clock signal remains in the high state. When only reception is performed, output of the synchronous clock continues until an overrun error occurs or the RE bit is cleared to 0. For the reception of n characters, select the external clock as the clock source. If the internal clock has to be used, set RE and TE to 1, then transmit n characters of dummy data at the same time as receiving the n characters of data.

(3) Transmitting and Receiving Data

SCI Initialization (Clock Synchronous Mode): Before transmitting, receiving, or changing the mode or communication format, the software must clear the TE and RE bits to 0 in the serial control register (SCSCR), then initialize the SCI. Clearing TE to 0 sets the TDRE flag to 1 and initializes the transmit shift register (SCTSR). Clearing RE to 0, however, does not initialize the RDRF, PER, FER, and ORER flags and receive data register (SCRDR), which retain their previous contents.

Figure 14.9 shows a sample flowchart for initializing the SCI.

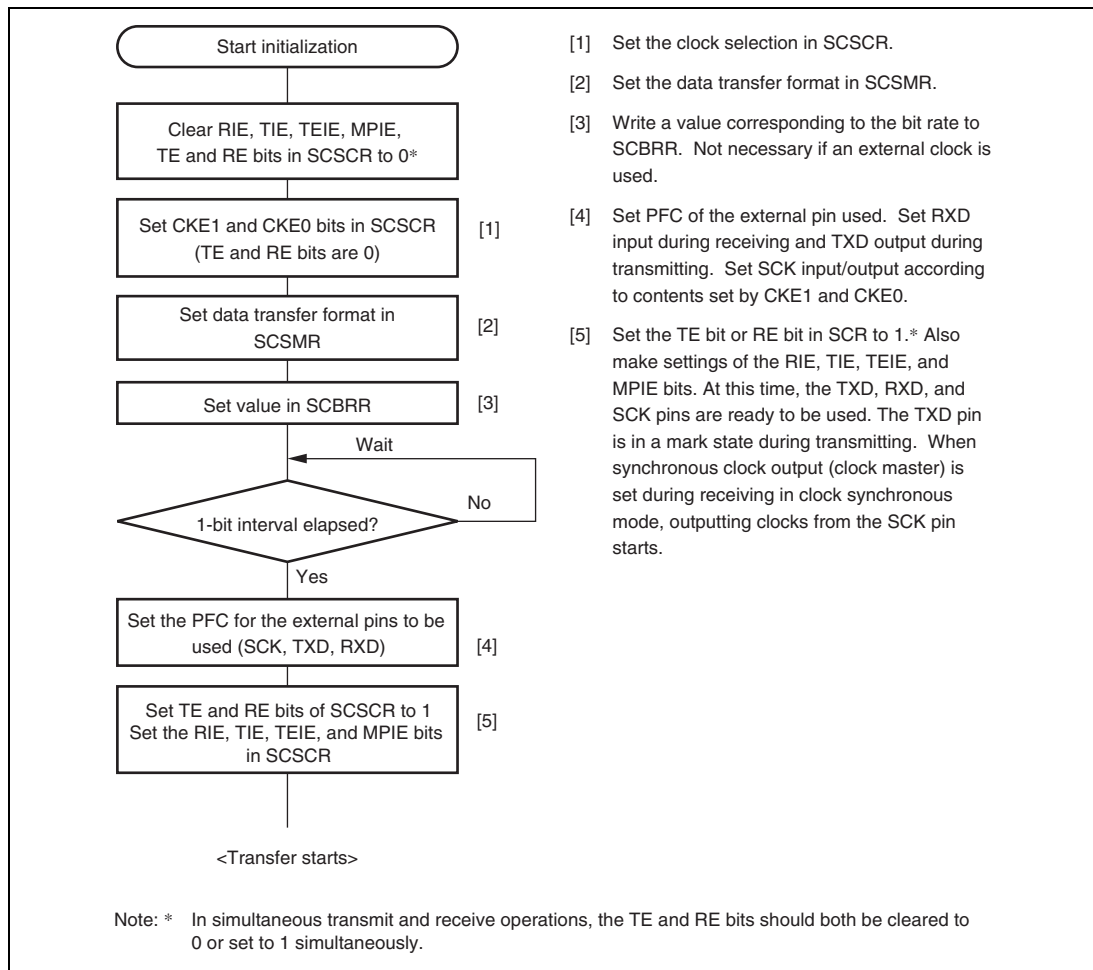

Figure 14.9 Sample Flowchart for SCI Initialization

Transmitting Serial Data (Clock Synchronous Mode): Figure 14.10 shows a sample flowchart for transmitting serial data.

Use the following procedure for serial data transmission after enabling the SCI for transmission.

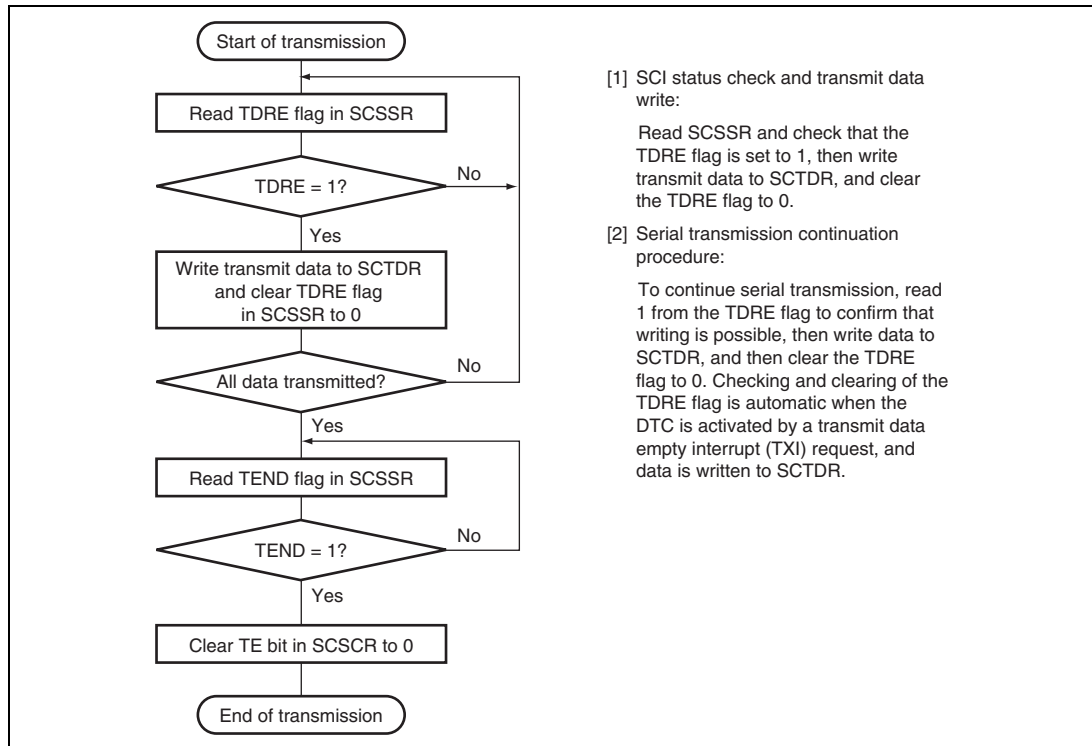

Figure 14.10 Sample Flowchart for Transmitting Serial Data

In transmitting serial data, the SCI operates as follows:

1. The SCI monitors the TDRE flag in the serial status register (SCSSR). If it is cleared to 0, the SCI recognizes that data has been written to the transmit data register (SCTDR) and transfers the data from SCTDR to the transmit shift register (SCTSR).
2. After transferring data from SCTDR to SCTSR, the SCI sets the TDRE flag to 1 and starts transmission. If the transmit-data-empty interrupt enable bit (TIE) in the serial control register (SCSCR) is set to 1 at this time, a transmit-data-empty interrupt (TXI) request is generated.
If clock output mode is selected, the SCI outputs eight synchronous clock pulses. If an external clock source is selected, the SCI outputs data in synchronization with the input clock. Data is output from the TXD pin in order from the LSB (bit 0) to the MSB (bit 7).
3. The SCI checks the TDRE flag at the timing for sending the MSB (bit 7). If the TDRE flag is 0, the data is transferred from SCTDR to SCTSR and serial transmission of the next frame is started. If the TDRE flag is 1, the TEND flag in SCSSR is set to 1, the MSB (bit 7) is sent, and then the TXD pin holds the states.
If the TEIE bit in SCSCR is set to 1 at this time, a TEI interrupt request is generated.
4. After the end of serial transmission, the SCK pin is held in the high state.

Figure 14.11 shows an example of SCI transmit operation.

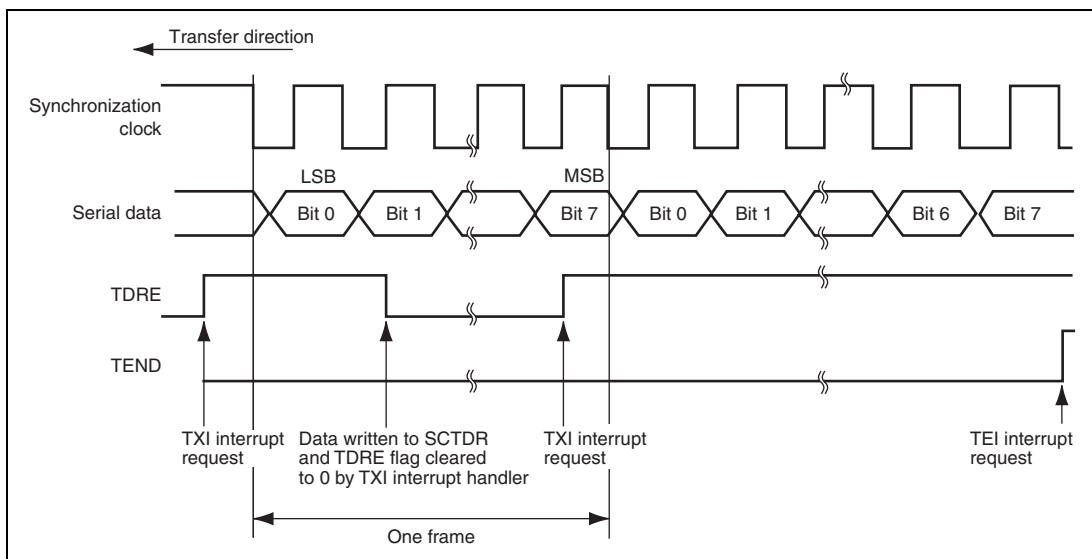

Figure 14.11 Example of SCI Transmit Operation

Receiving Serial Data (Clock Synchronous Mode): Figure 14.12 shows a sample flowchart for receiving serial data. Use the following procedure for serial data reception after enabling the SCIF for reception.

When switching from asynchronous mode to clock synchronous mode, make sure that the ORER, PER, and FER flags are all cleared to 0. If the FER or PER flag is set to 1, the RDRF flag will not be set and data reception cannot be started.

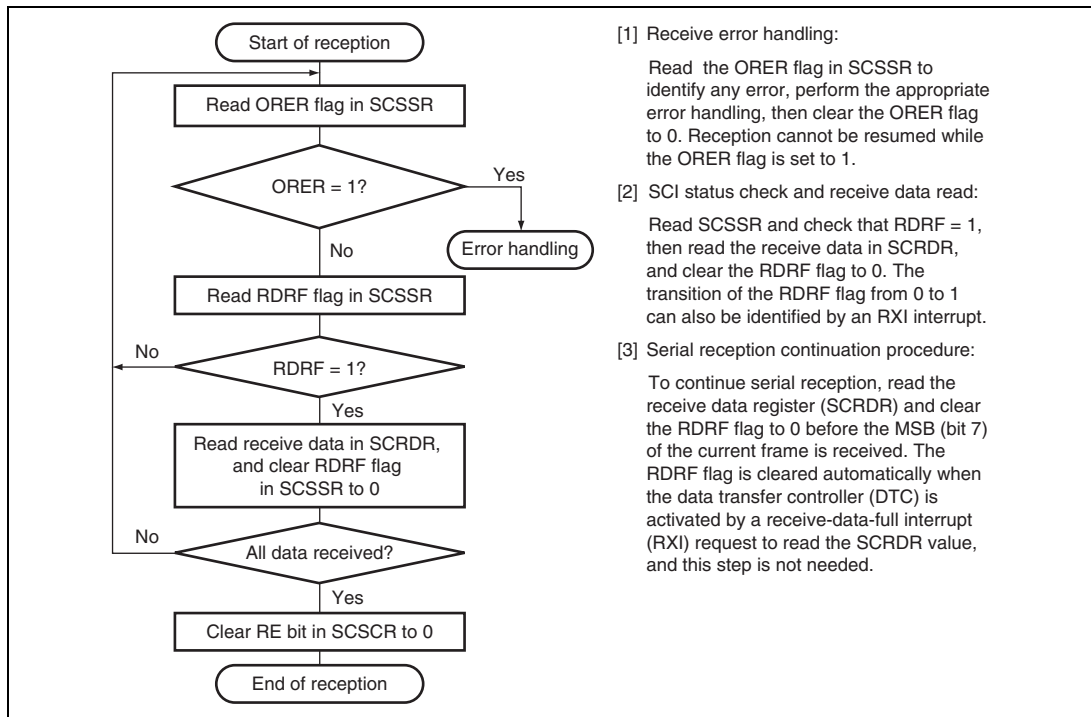

Figure 14.12 Sample Flowchart for Receiving Serial Data (1)

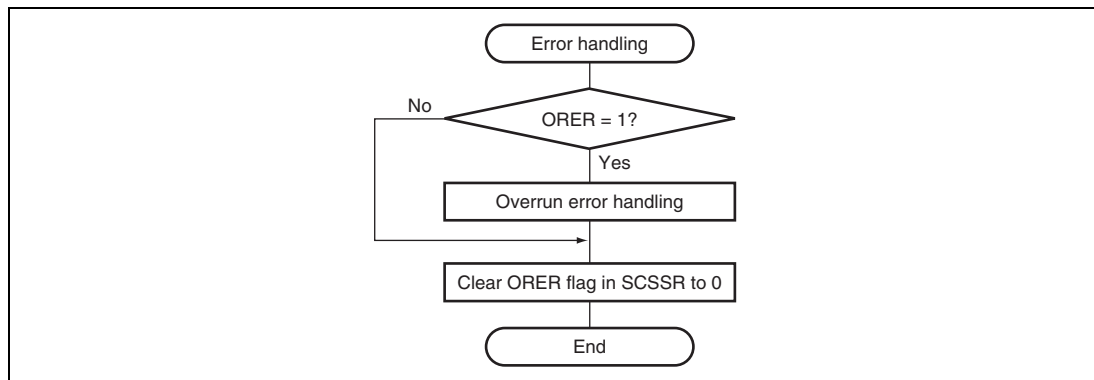

Figure 14.12 Sample Flowchart for Receiving Serial Data (2)

In receiving, the SCI operates as follows:

1. The SCI synchronizes with serial clock input or output and initializes internally.
2. Receive data is shifted into SCRSR in order from the LSB to the MSB. After receiving the data, the SCI checks whether the RDRF flag is 0 and the receive data can be transferred from SCRSR to SCRDR. If this check is passed, the SCI sets the RDRF flag to 1 and stores the received data in SCRDR. If a receive error is detected, the SCI operates as shown in table 14.16. In this state, subsequent reception cannot be continued. In addition, the RDRF flag will not be set to 1 after reception; be sure to clear the RDRF flag to 0.
3. After setting RDRF to 1, if the receive-data-full interrupt enable bit (RIE) is set to 1 in SCSCR, the SCI requests a receive-data-full interrupt (RXI). If the ORER bit is set to 1 and the RIE bit in SCSCR is also set to 1, the SCI requests a receive error interrupt (ERI).

Figure 14.13 shows an example of SCI receive operation.

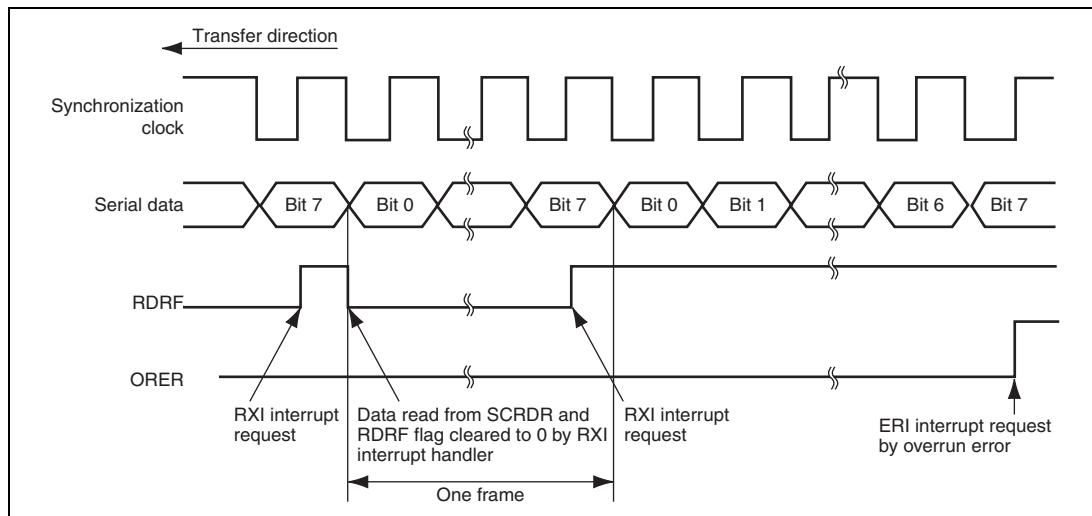

Figure 14.13 Example of SCI Receive Operation

Transmitting and Receiving Serial Data Simultaneously (Clock Synchronous Mode): Figure 14.14 shows a sample flowchart for transmitting and receiving serial data simultaneously.

Use the following procedure for serial data transmission and reception after enabling the SCI for transmission and reception.

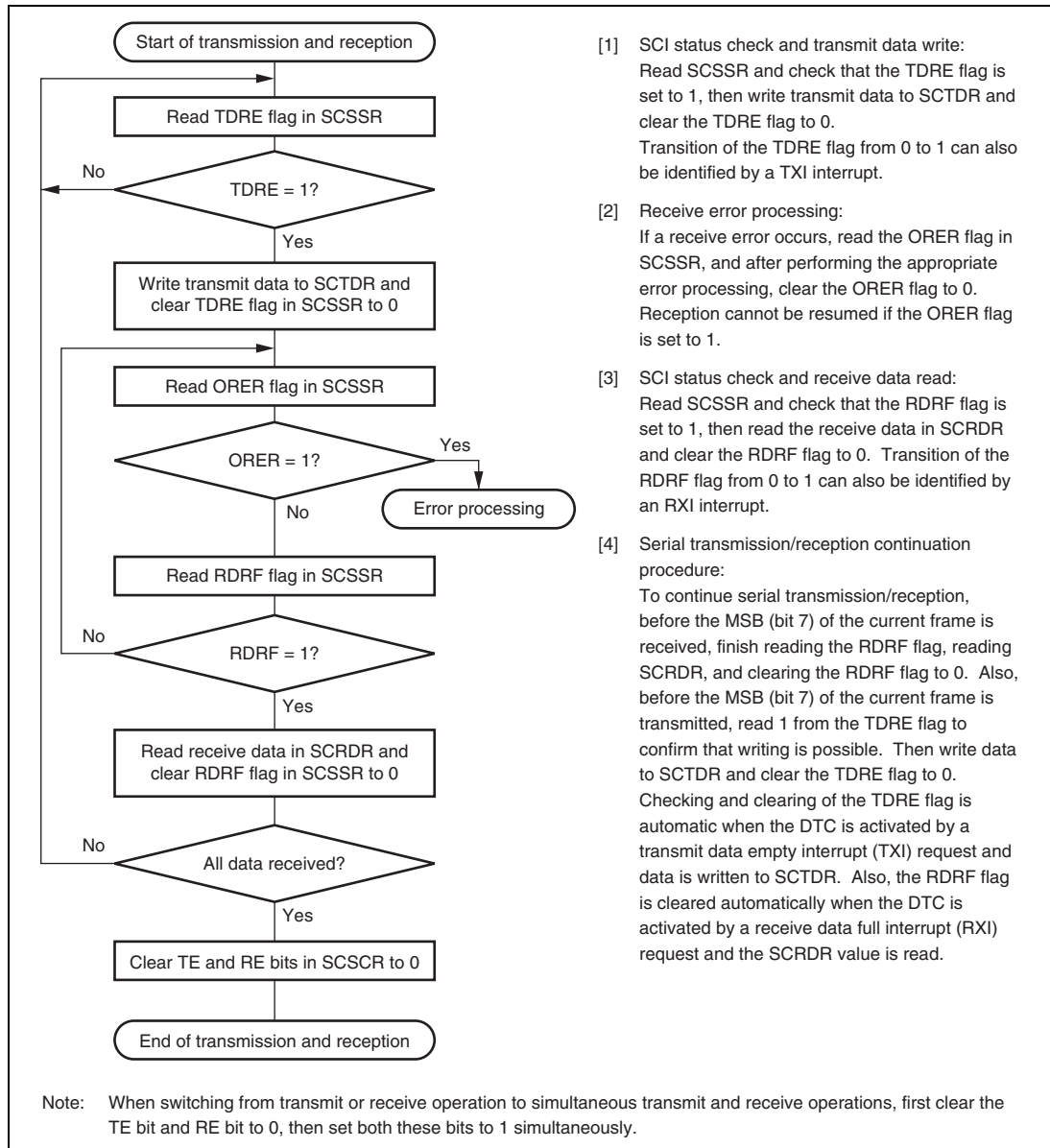

Figure 14.14 Sample Flowchart for Transmitting/Receiving Serial Data

14.4.4 Multiprocessor Communication Function

Use of the multiprocessor communication function enables data transfer to be performed among a number of processors sharing communication lines by means of asynchronous serial communication using the multiprocessor format, in which a multiprocessor bit is added to the transfer data. When multiprocessor communication is carried out, each receiving station is addressed by a unique ID code. The serial communication cycle consists of two component cycles: an ID transmission cycle which specifies the receiving station, and a data transmission cycle. The multiprocessor bit is used to differentiate between the ID transmission cycle and the data transmission cycle. If the multiprocessor bit is 1, the cycle is an ID transmission cycle, and if the multiprocessor bit is 0, the cycle is a data transmission cycle. Figure 14.15 shows an example of inter-processor communication using the multiprocessor format. The transmitting station first sends the ID code of the receiving station with which it wants to perform serial communication as data with a 1 multiprocessor bit added. It then sends transmit data as data with a 0 multiprocessor bit added. The receiving station skips data until data with a 1 multiprocessor bit is sent. When data with a 1 multiprocessor bit is received, the receiving station compares that data with its own ID. The station whose ID matches then receives the data sent next. Stations whose ID does not match continue to skip data until data with a 1 multiprocessor bit is again received.

The SCI uses the MPIE bit in SCSCR to implement this function. When the MPIE bit is set to 1, transfer of receive data from SCRSR to SCRDR, error flag detection, and setting the SCSSR status flags, RDRF, FER, and OER to 1 are inhibited until data with a 1 multiprocessor bit is received. On reception of receive character with a 1 multiprocessor bit, the MPBR bit in SCSSR is set to 1 and the MPIE bit is automatically cleared, thus normal reception is resumed. If the RIE bit in SCSCR is set to 1 at this time, an RXI interrupt is generated.

When the multiprocessor format is selected, the parity bit setting is invalid. All other bit settings are the same as those in normal asynchronous mode. The clock used for multiprocessor communication is the same as that in normal asynchronous mode.

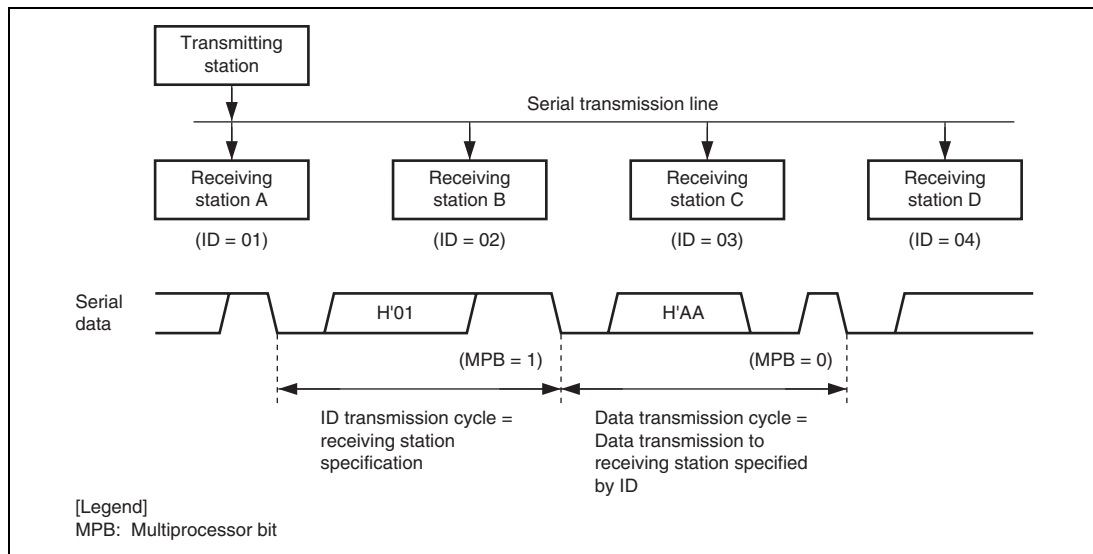

**Figure 14.15 Example of Communication Using Multiprocessor Format
(Transmission of Data H'AA to Receiving Station A)**

14.4.5 Multiprocessor Serial Data Transmission

Figure 14.16 shows a sample flowchart for multiprocessor serial data transmission. For an ID transmission cycle, set the MPBT bit in SCSSR to 1 before transmission. Maintain the MPBT value at 1 until the ID transmission actually completes. For a data transmission cycle, clear the MPBT bit in SCSSR to 0 before transmission. All other SCI operations are the same as those in asynchronous mode.

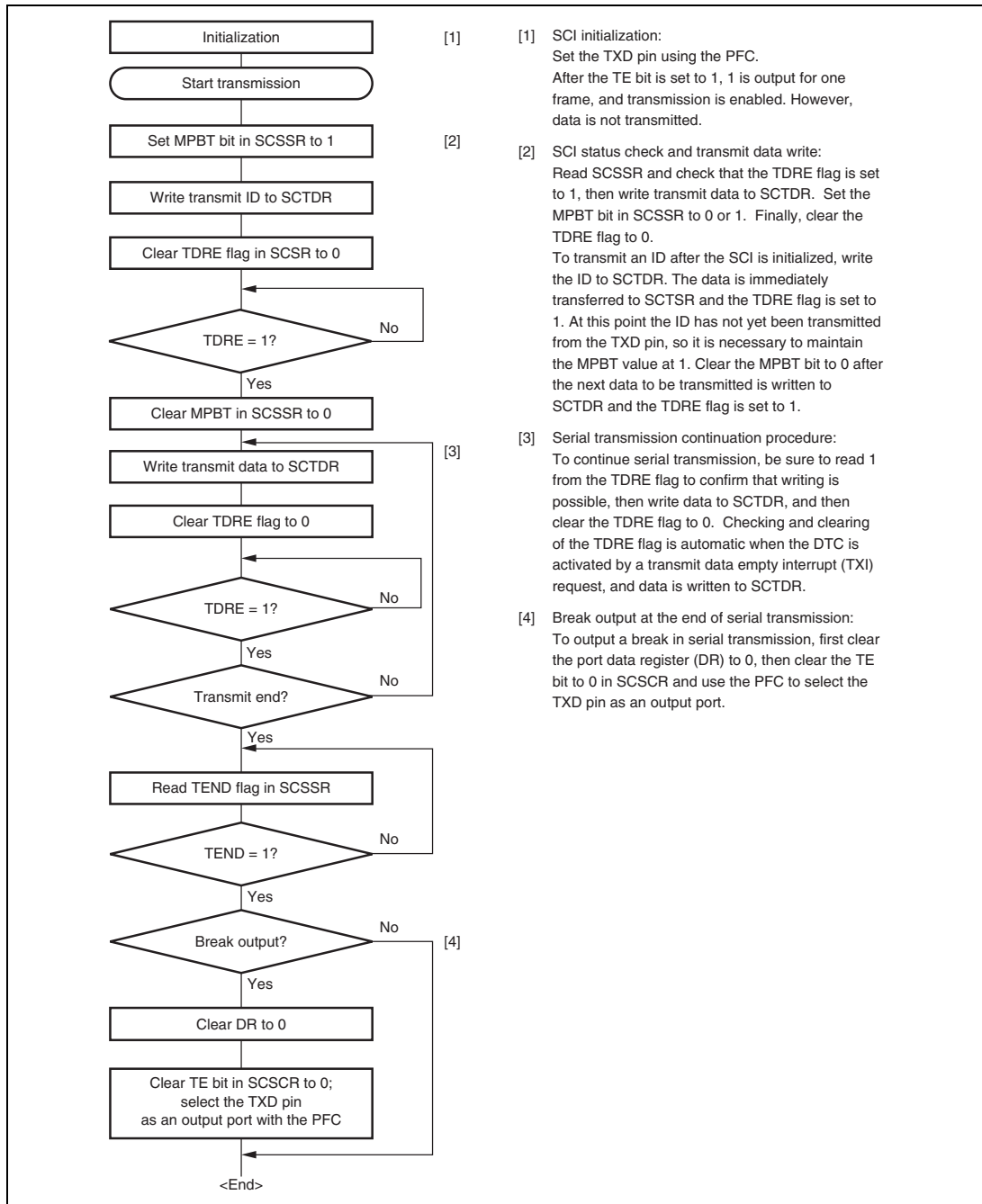

Figure 14.16 Sample Multiprocessor Serial Transmission Flowchart

14.4.6 Multiprocessor Serial Data Reception

Figure 14.18 shows a sample flowchart for multiprocessor serial data reception. If the MPIE bit in SCSCR is set to 1, data is skipped until data with a 1 multiprocessor bit is sent. On receiving data with a 1 multiprocessor bit, the receive data is transferred to SCRDR. An RXI interrupt request is generated at this time. All other SCI operations are the same as in asynchronous mode. Figure 14.17 shows an example of SCI operation for multiprocessor format reception.

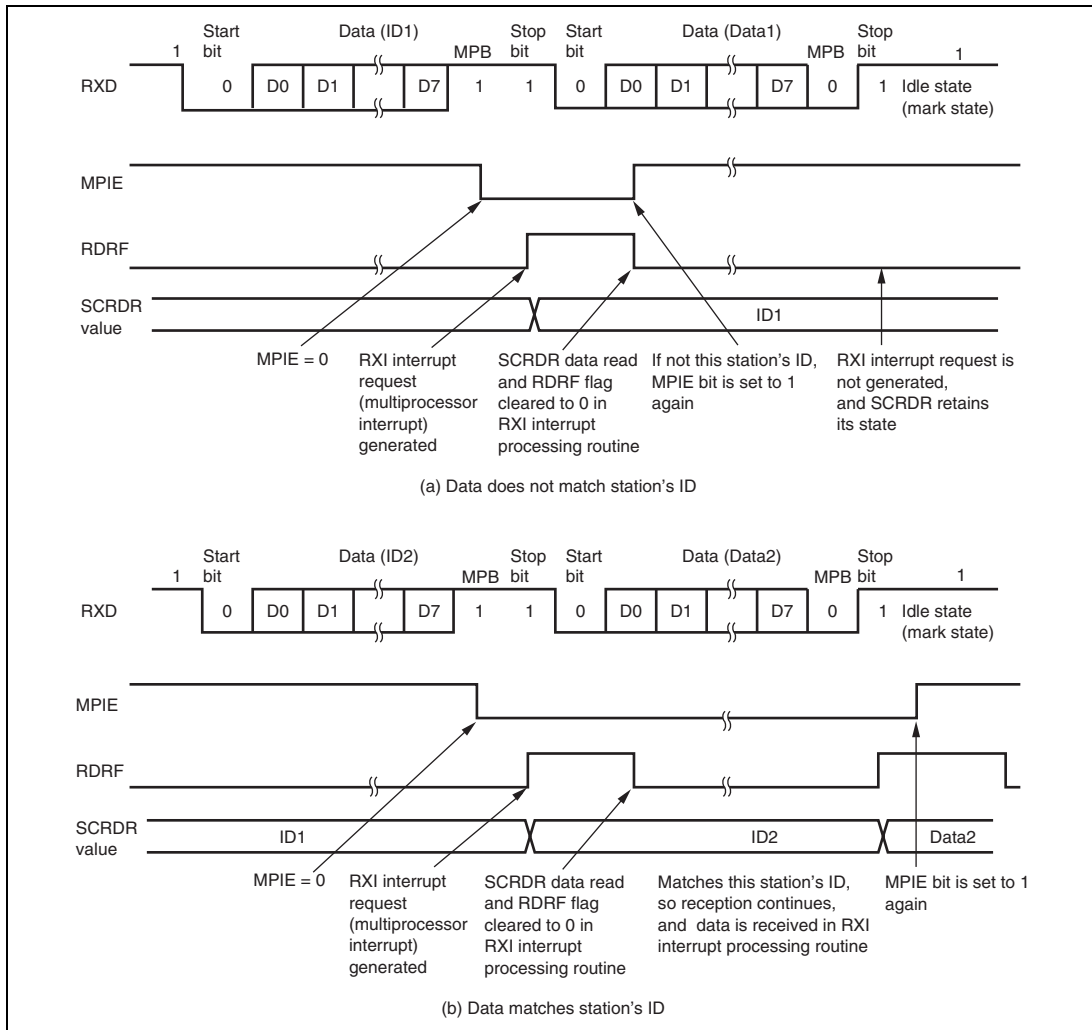

Figure 14.17 Example of SCI Operation in Reception (Example with 8-Bit Data, Multiprocessor Bit, One Stop Bit)

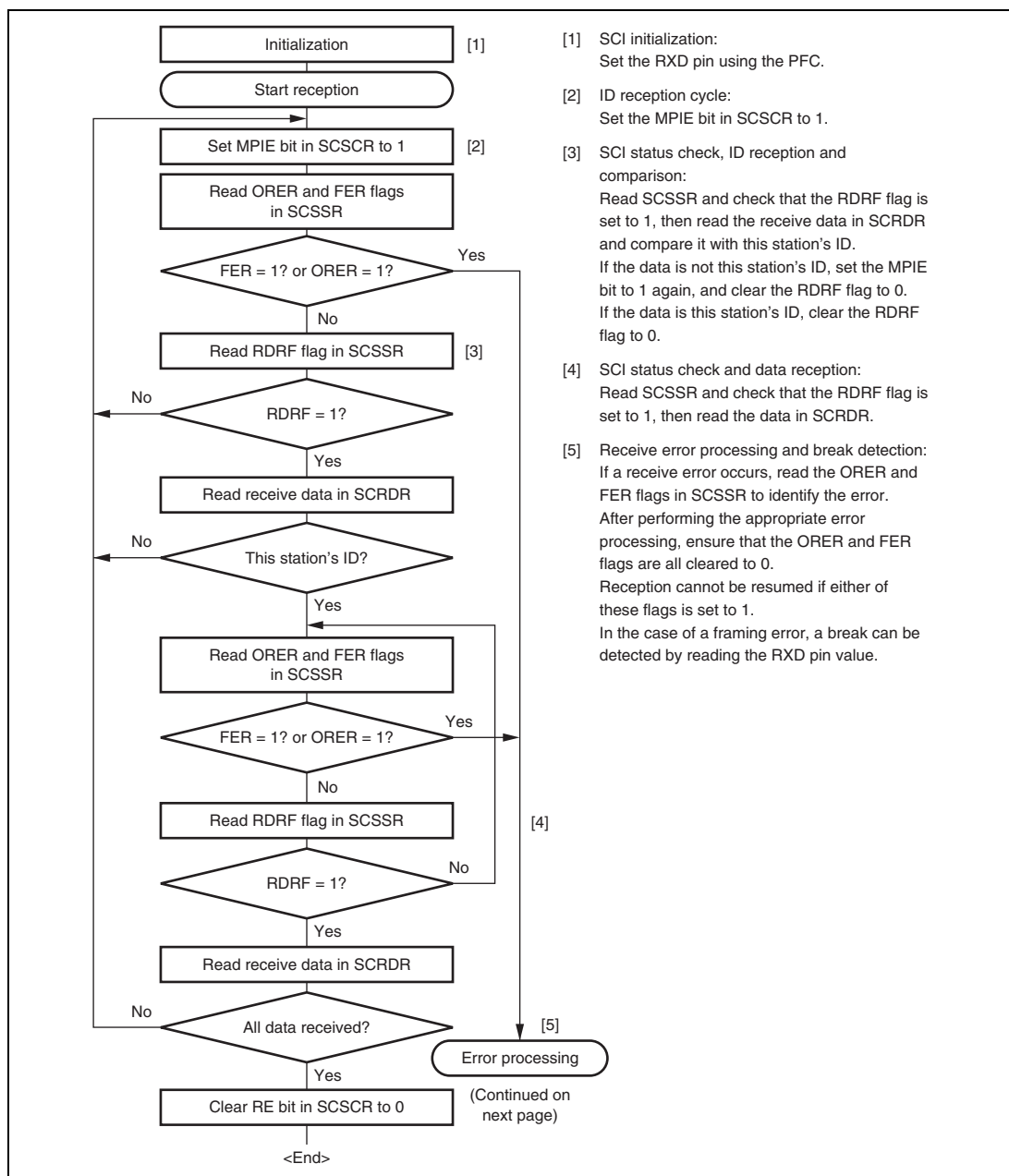
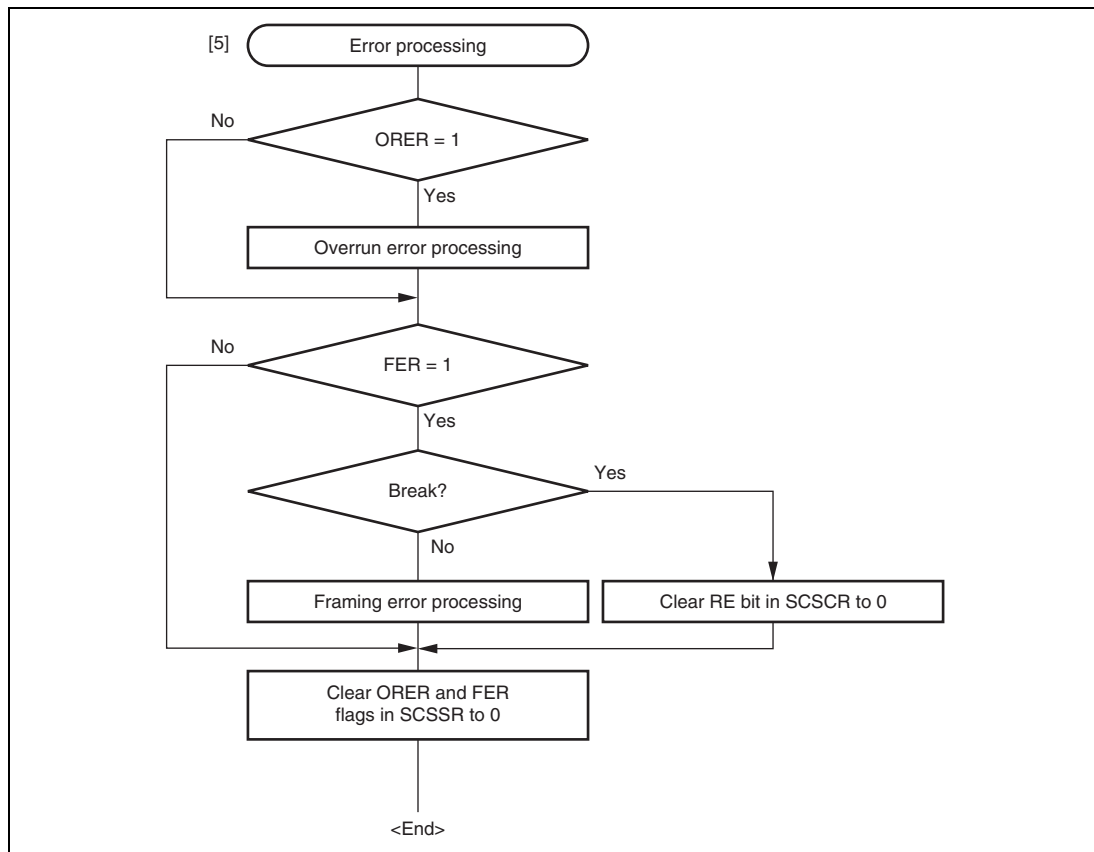

Figure 14.18 Sample Multiprocessor Serial Reception Flowchart (1)

**Figure 14.18 Sample Multiprocessor Serial Reception Flowchart (2)**

14.5 SCI Interrupt Sources and DTC

The SCI has four interrupt sources: transmit end (TEI), receive error (ERI), receive-data-full (RXI), and transmit-data-empty (TXI) interrupt requests.

Table 14.17 shows the interrupt sources. The interrupt sources are enabled or disabled by means of the TIE, RIE, and TEIE bits in SCSCR and the EIO bit in SCSPTR. A separate interrupt request is sent to the interrupt controller for each of these interrupt sources.

When the TDRE flag in the serial status register (SCSSR) is set to 1, a TDR empty interrupt request is generated. This request can be used to activate the data transfer controller (DTC) to transfer data. The TDRE flag is automatically cleared to 0 when data is written to the transmit data register (SCTDR) through the DTC.

When the RDRF flag in SCSSR is set to 1, an RDR full interrupt request is generated. This request can be used to activate the DTC to transfer data. The RDRF flag is automatically cleared to 0 when data is read from the receive data register (SCRDR) through the DTC.

When the ORER, FER, or PER flag in SCSSR is set to 1, an ERI interrupt request is generated. This request cannot be used to activate the DTC. It is possible to disable generation of RXI interrupt requests and allow only ERI interrupt requests to be generated during data reception processing. To accomplish this, set the RIE bit to 1 and the EIO bit in SCSPTR to 1. Note that setting the EIO bit to 1 will prevent the DTC from transferring received data because no ERI interrupt requests are generated.

When the TEND flag in SCSSR is set to 1, a TEI interrupt request is generated. This request cannot be used to activate the DTC.

The TXI interrupt indicates that transmit data can be written, and the TEI interrupt indicates that transmission has been completed.

Table 14.17 SCI Interrupt Sources

Interrupt Source	Description	DTC Activation
ERI	Interrupt caused by receive error (ORER, FER, or PER)	Not possible
RXI	Interrupt caused by receive data full (RDRF)	Possible
TXI	Interrupt caused by transmit data empty (TDRE)	Possible
TEI	Interrupt caused by transmit end (TENT)	Not possible

14.6 Serial Port Register (SCSPTR) and SCI Pins

The relationship between SCSPTR and the SCI pins is shown in figures 14.19 and 14.20.

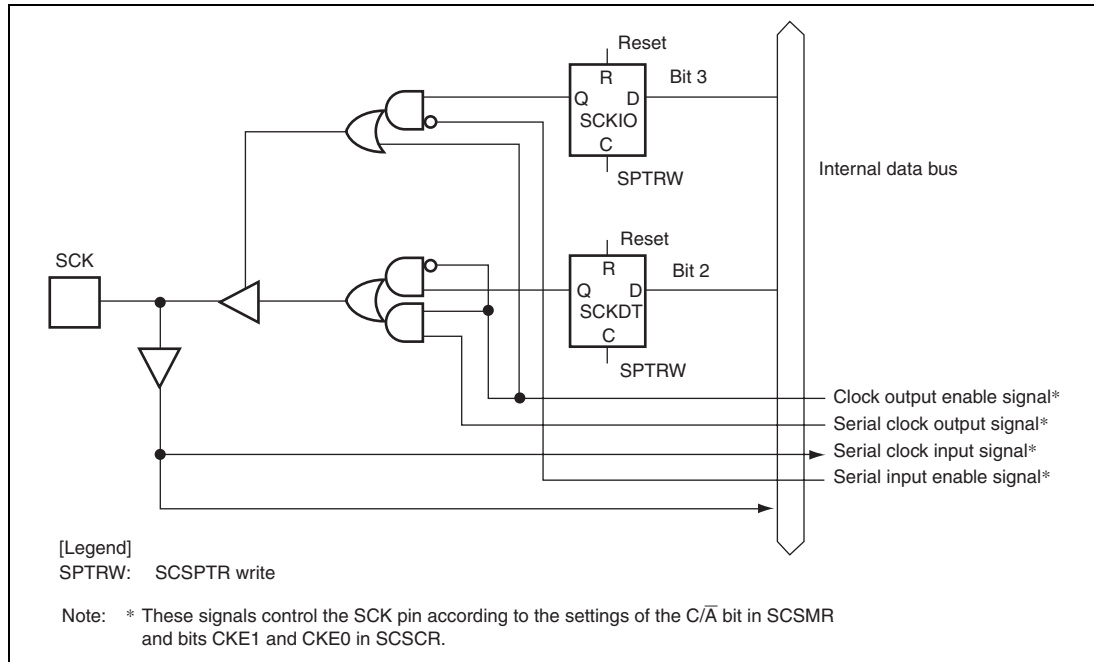

Figure 14.19 SCKIO Bit, SCKDT Bit, and SCK Pin

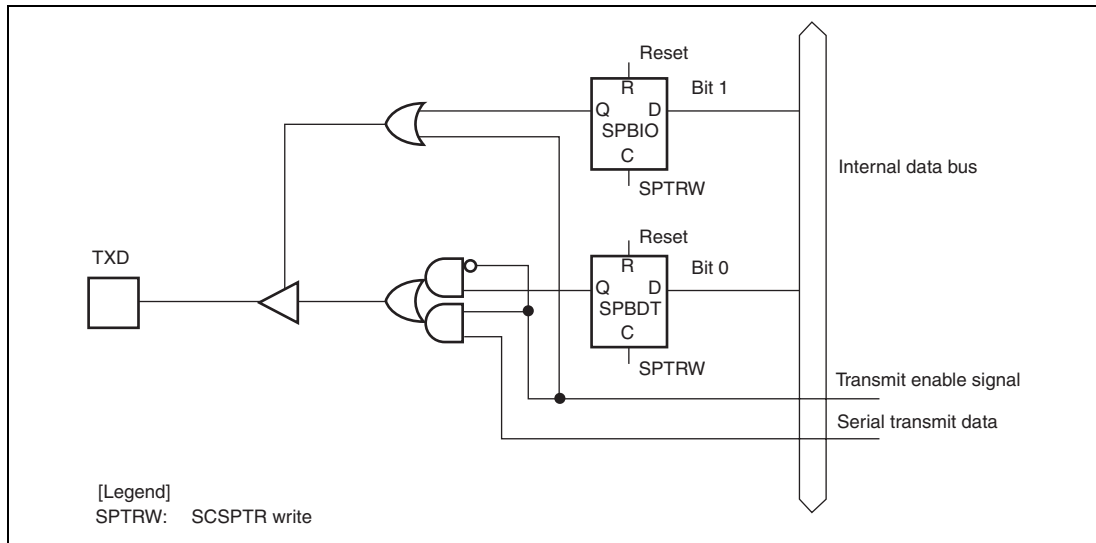

Figure 14.20 SPBIO Bit, SPBDT Bit, and TXD Pin

14.7 Usage Notes

14.7.1 SCTDR Writing and TDRE Flag

The TDRE flag in the serial status register (SCSSR) is a status flag indicating transferring of transmit data from SCTDR into SCTSR. The SCI sets the TDRE flag to 1 when it transfers data from SCTDR to SCTSR.

Data can be written to SCTDR regardless of the TDRE bit status.

If new data is written in SCTDR when TDRE is 0, however, the old data stored in SCTDR will be lost because the data has not yet been transferred to SCTSR. Before writing transmit data to SCTDR, be sure to check that the TDRE flag is set to 1.

14.7.2 Multiple Receive Error Occurrence

If multiple receive errors occur at the same time, the status flags in SCSSR are set as shown in table 14.18. When an overrun error occurs, data is not transferred from the receive shift register (SCRSR) to the receive data register (SCRDR) and the received data will be lost.

Table 14.18 SCSSR Status Flag Values and Transfer of Received Data

Receive Errors Generated	SCSSR Status Flags				Receive Data Transfer from SCRSR to SCRDR
	RDRF	ORER	FER	PER	
Overrun error	1	1	0	0	Not transferred
Framing error	0	0	1	0	Transferred
Parity error	0	0	0	1	Transferred
Overrun error + framing error	1	1	1	0	Not transferred
Overrun error + parity error	1	1	0	1	Not transferred
Framing error + parity error	0	0	1	1	Transferred
Overrun error + framing error + parity error	1	1	1	1	Not transferred

14.7.3 Break Detection and Processing

Break signals can be detected by reading the RXD pin directly when a framing error (FER) is detected. In the break state the input from the RXD pin consists of all 0s, so the FER flag is set and the parity error flag (PER) may also be set. Note that, although transfer of receive data to SCRDR is halted in the break state, the SCI receiver continues to operate.

14.7.4 Sending a Break Signal

The I/O condition and level of the TXD pin are determined by the SPB0IO and SPB0DT bits in the serial port register (SCSPTR). This feature can be used to send a break signal.

Until TE bit is set to 1 (enabling transmission) after initializing, TXD pin does not work. During the period, mark status is performed by SPB0DT bit. Therefore, the SPB0IO and SPB0DT bits should be set to 1 (high level output).

To send a break signal during serial transmission, clear the SPB0DT bit to 0 (low level), then clear the TE bit to 0 (halting transmission). When the TE bit is cleared to 0, the transmitter is initialized regardless of the current transmission state, and 0 is output from the TXD pin.

14.7.5 Receive Data Sampling Timing and Receive Margin (Asynchronous Mode)

The SCI operates on a base clock with a frequency of 16 times the transfer rate in asynchronous mode. In reception, the SCI synchronizes internally with the fall of the start bit, which it samples on the base clock. Receive data is latched at the rising edge of the eighth base clock pulse. The timing is shown in figure 14.21.

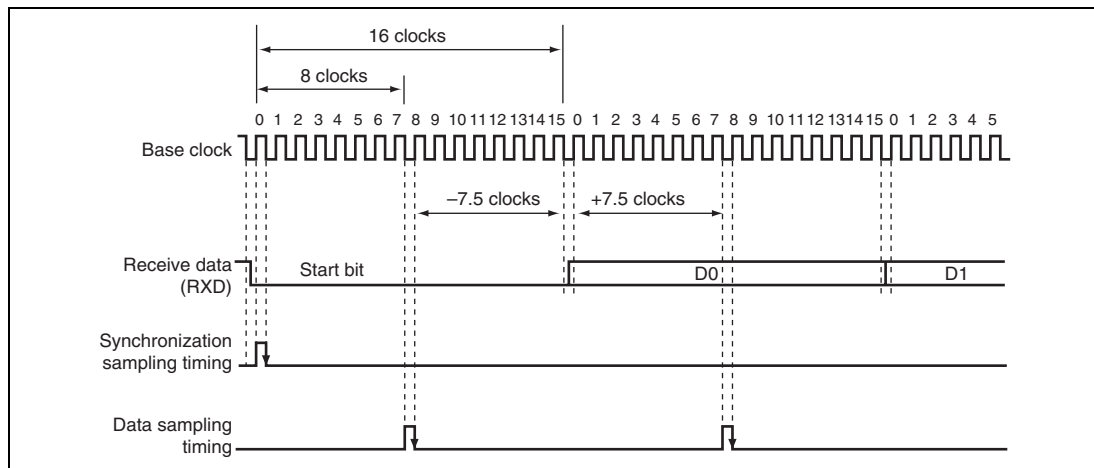

Figure 14.21 Receive Data Sampling Timing in Asynchronous Mode

The receive margin in asynchronous mode can therefore be expressed as shown in equation 1.

Equation 1:

$$M = \left| \left(0.5 - \frac{1}{2N} \right) - (L - 0.5) F - \frac{|D - 0.5|}{N} (1 + F) \right| \times 100 \%$$

Where:

- M: Receive margin (%)
- N: Ratio of bit rate to clock (N = 16)
- D: Clock duty (D = 0 to 1.0)
- L: Frame length (L = 9 to 12)
- F: Absolute deviation of clock frequency

From equation 1, if F = 0 and D = 0.5, the receive margin is 46.875%, as given by equation 2.

Equation 2:

When D = 0.5 and F = 0:

$$M = (0.5 - 1/(2 \times 16)) \times 100\% \\ = 46.875\%$$

This is a theoretical value. A reasonable margin to allow in system designs is 20% to 30%.

14.7.6 Note on Using DTC

When the external clock source is used for the clock for synchronization, input the external clock after waiting for five or more cycles of the peripheral operating clock after SCTDR is modified through the DTC. If a transmit clock is input within four cycles after SCTDR is modified, a malfunction may occur (figure 14.22).

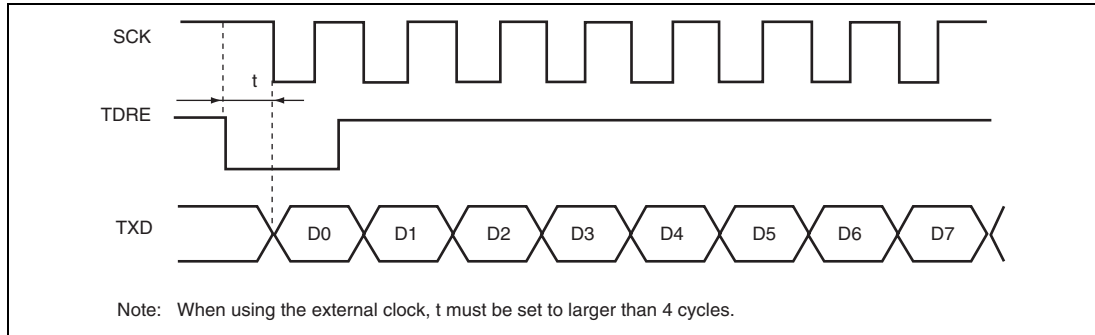

Figure 14.22 Example of Clock Synchronous Transfer Using DTC

When data is written to SCTDR by activating the DTC by a TXI interrupt, the TEND flag value becomes undefined. In this case, do not use the TEND flag as the transmit end flag.

14.7.7 Note on Using External Clock in Clock Synchronous Mode

TE and RE must be set to 1 after waiting for four or more cycles of the peripheral operating clock after the SCK external clock is changed from 0 to 1.

TE and RE must be set to 1 only while the SCK external clock is 1.

14.7.8 Module Standby Mode Setting

SCI operation can be disabled or enabled using the standby control register. The initial setting is for SCI operation to be halted. Register access is enabled by clearing module standby mode. For details, refer to section 22, Power-Down Modes.

Section 15 A/D Converter (ADC)

This LSI includes a successive approximation type 10-bit A/D converter.

15.1 Features

- 10-bit resolution
- Input channels
 - 12 channels (three independent A/D conversion modules)
- Conversion time: 2.0 μ s per channel (operation when P ϕ = 25 MHz)
- Three operating modes
 - Single mode: Single-channel A/D conversion
 - Continuous scan mode: Repetitive A/D conversion on up to eight channels
 - Single-cycle scan mode: Continuous A/D conversion on up to eight channels
- Data registers
 - Conversion results are held in a 16-bit data register for each channel
- Sample-and-hold function
- Three methods for conversion start
 - Software
 - Conversion start trigger from multifunction timer pulse unit 2 (MTU2) or multifunction timer pulse unit 2S (MTU2S)
 - External trigger signal
- Interrupt request
 - An A/D conversion end interrupt request (ADI) can be generated
- Module standby mode can be set

Figure 15.1 shows a block diagram of the A/D converter.

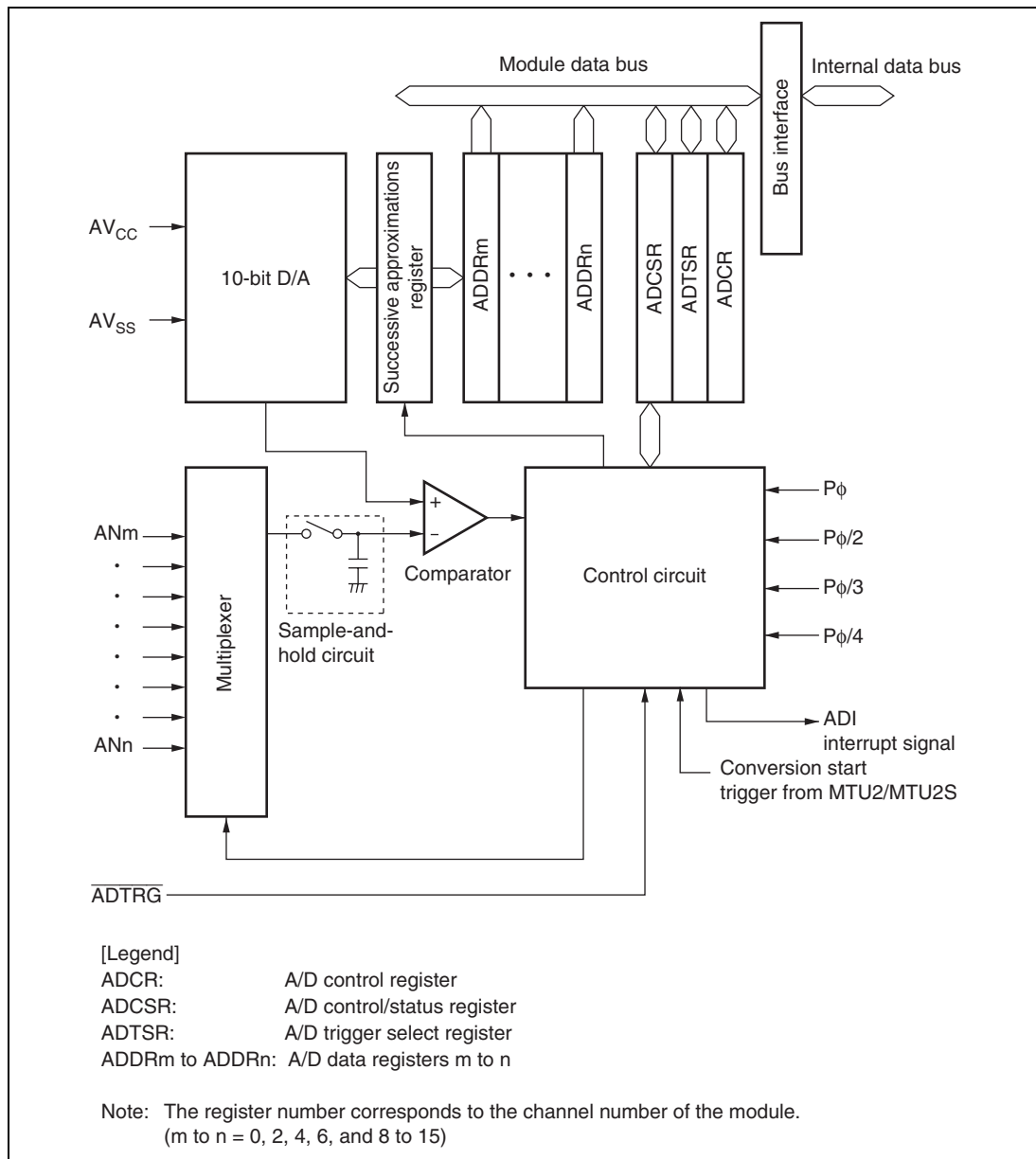

Figure 15.1 Block Diagram of A/D Converter (for One Module)

15.2 Input/Output Pins

Table 15.1 summarizes the input pins used by the A/D converter. This LSI has three A/D conversion modules, each of which can be operated independently. The input channels of A/D modules 0 and 1 are divided into two channel groups.

Table 15.1 Pin Configuration

Module Type	Pin Name	I/O	Function
Common	AV _{cc}	Input	Analog block power supply and reference voltage
	AV _{ss}	Input	Analog block ground and reference voltage
	ADTRG	Input	A/D external trigger input pin
A/D module 0 (A/D_0)	AN0	Input	Analog input pin 0 (Group 0)
	AN2	Input	Analog input pin 2 (Group 1)
A/D module 1 (A/D_1)	AN4	Input	Analog input pin 4 (Group 0)
	AN6	Input	Analog input pin 6 (Group 1)
A/D module 2 (A/D_2)	AN8	Input	Analog input pin 8
	AN9	Input	Analog input pin 9
	AN10	Input	Analog input pin 10
	AN11	Input	Analog input pin 11
	AN12	Input	Analog input pin 12
	AN13	Input	Analog input pin 13
	AN14	Input	Analog input pin 14
	AN15	Input	Analog input pin 15

Note: The connected A/D module differs for each pin. The control registers of each module must be set.

15.3 Register Descriptions

The A/D converter has the following registers. For details on register addresses and register states in each processing state, refer to section 23, List of Registers.

Table 15.2 Register Configuration

Register Name	Abbreviation	R/W	Initial Value	Address	Access Size
A/D data register 0	ADDR0	R	H'0000	H'FFFC900	16
A/D data register 2	ADDR2	R	H'0000	H'FFFC904	16
A/D control/status register_0	ADCSR_0	R/W	H'0000	H'FFFC910	16
A/D control register_0	ADCR_0	R/W	H'0000	H'FFFC912	16
A/D data register 4	ADDR4	R	H'0000	H'FFFC980	16
A/D data register 6	ADDR6	R	H'0000	H'FFFC984	16
A/D control/status register_1	ADCSR_1	R/W	H'0000	H'FFFC990	16
A/D control register_1	ADCR_1	R/W	H'0000	H'FFFC992	16
A/D data register 8	ADDR8	R	H'0000	H'FFFC A00	16
A/D data register 9	ADDR9	R	H'0000	H'FFFC A02	16
A/D data register 10	ADDR10	R	H'0000	H'FFFC A04	16
A/D data register 11	ADDR11	R	H'0000	H'FFFC A06	16
A/D data register 12	ADDR12	R	H'0000	H'FFFC A08	16
A/D data register 13	ADDR13	R	H'0000	H'FFFC A0A	16
A/D data register 14	ADDR14	R	H'0000	H'FFFC A0C	16
A/D data register 15	ADDR15	R	H'0000	H'FFFC A0E	16
A/D control/status register_2	ADCSR_2	R/W	H'0000	H'FFFC A10	16
A/D control register_2	ADCR_2	R/W	H'0000	H'FFFC A12	16
A/D trigger select register_0	ADTSR_0	R/W	H'0000	H'FFFE890	8, 16
A/D trigger select register_1	ADTSR_1	R/W	H'0000	H'FFFE892	8, 16

15.3.1 A/D Data Registers 0, 2, 4, 6, and 8 to 15 (ADDR0, ADDR2, ADDR4, ADDR6, and ADDR8 to ADDR15)

ADDRs are 16-bit read-only registers. The conversion result for each analog input channel is stored in ADDR with the corresponding number. For example, the conversion result of AN4 is stored in ADDR4.

The converted 10-bit data is stored in bits 6 to 15. The lower 6 bits are always read as 0.

The initial value of ADDR is H'0000.

Bit:	15	14	13	12	11	10	9	8	7	6	5	4	3	2	1	0
Initial value:	0	0	0	0	0	0	0	0	0	0	0	0	0	0	0	0
R/W:	R	R	R	R	R	R	R	R	R	R	R	R	R	R	R	R

Bit	Bit Name	Initial Value	R/W	Description
15 to 6		All 0	R	Bit Data (10 bits)
5 to 0	—	All 0	R	Reserved These bits are always read as 0. The write value should always be 0.

15.3.2 A/D Control/Status Registers_0 to _2 (ADCSR_0 to ADCSR_2)

ADCSR for each module controls A/D conversion operations.

Bit:	15	14	13	12	11	10	9	8	7	6	5	4	3	2	1	0
	ADF	ADIE	-	-	TRGE	-	CONADF	STC	CKSL[1:0]	ADM[1:0]	ADCS	CH[2:0]				
Initial value:	0	0	0	0	0	0	0	0	0	0	0	0	0	0	0	0
R/W:	R/(W)*	R/W	R	R	R/W	R	R/W	R/W	R/W	R/W	R/W	R/W	R/W	R/W	R/W	R/W

Note: * Writing 0 to this bit after reading it as 1 clears the flag and is the only allowed way.

Bit	Bit Name	Initial Value	R/W	Description
15	ADF	0	R/(W)*	<p>A/D End Flag</p> <p>A status flag that indicates the end of A/D conversion.</p> <p>[Setting conditions]</p> <ul style="list-style-type: none"> When A/D conversion ends in single mode When A/D conversion ends on all specified channels in scan mode <p>[Clearing conditions]</p> <ul style="list-style-type: none"> When 0 is written after reading ADF = 1 When the DTC is activated by an ADI interrupt and ADDR is read
14	ADIE	0	R/W	<p>A/D Interrupt Enable</p> <p>The A/D conversion end interrupt (ADI) request is enabled when 1 is set</p> <p>When changing the operating mode, first clear the ADST bit to 0.</p>
13, 12	—	All 0	R	<p>Reserved</p> <p>These bits are always read as 0. The write value should always be 0.</p>
11	TRGE	0	R/W	<p>Trigger Enable</p> <p>Enables or disables triggering of A/D conversion by $\overline{\text{ADTRG}}$, an MTU2 trigger, or an MTU2S trigger.</p> <p>0: A/D conversion triggering is disabled</p> <p>1: A/D conversion triggering is enabled</p> <p>When changing the operating mode, first clear the ADST bit to 0.</p>

Bit	Bit Name	Initial Value	R/W	Description
10	—	0	R	Reserved This bit is always read as 0. The write value should always be 0.
9	CONADF	0	R/W	ADF Control Controls setting of the ADF bit in 2-channel scan mode. The setting of this bit is valid only when triggering of A/D conversion is enabled (TRGE = 1) in 2-channel scan mode. The setting of this bit is ignored in single mode, 4-channel scan mode, or 8-channel scan mode. 0: The ADF bit is set when A/D conversion started by the group 0 trigger or group 1 trigger has finished. 1: The ADF bit is set when A/D conversion started by the group 0 trigger and A/D conversion started by the group 1 trigger have both finished. Note that the triggering order has no affect. When changing the operating mode, first clear the ADST bit to 0.
8	STC	0	R/W	State Control Sets the A/D conversion time in combination with the CKSL1 and CKSL0 bits. 0: 50 states 1: 64 states When changing the A/D conversion time, first clear the ADST bit to 0.
7, 6	CKSL[1:0]	00	R/W	Clock Select 1 and 0 Select the A/D conversion time. 00: $P\phi/4$ 01: $P\phi/3$ 10: $P\phi/2$ 11: $P\phi$ When changing the A/D conversion time, first clear the ADST bit to 0. CKSL[1:0] = B'11 can be set while $P\phi \leq 25$ [MHz].

Bit	Bit Name	Initial Value	R/W	Description
5, 4	ADM[1:0]	00	R/W	<p>A/D Mode 1 and 0</p> <p>Select the A/D conversion mode. 2-channel scan mode is supported only by A/D modules 0 and 1. Do not select 2-channel scan mode in A/D module 2.</p> <p>00: Single mode 01: 4-channel scan mode 10: 8-channel scan mode 11: 2-channel scan mode</p> <p>When changing the operating mode, first clear the ADST bit to 0.</p>
3	ADCS	0	R/W	<p>A/D Continuous Scan</p> <p>Selects either single-cycle scan or continuous scan in scan mode. This bit is valid only when scan mode is selected.</p> <p>0: Single-cycle scan 1: Continuous scan</p> <p>When changing the operating mode, first clear the ADST bit to 0.</p>
2 to 0	CH[2:0]	000	R/W	<p>Channel Select 2 to 0</p> <p>Select analog input channels. See table 15.3.</p> <p>When changing the operating mode, first clear the ADST bit to 0.</p>

Note: * Writing 0 to this bit after reading it as 1 clears the flag and is the only allowed way.

15.3.3 A/D Control Registers_0 to _2 (ADCR_0 to ADCR_2)

ADCR for each module controls A/D conversion.

Bit:	15	14	13	12	11	10	9	8	7	6	5	4	3	2	1	0
	-	-	ADST	-	-	-	-	-	-	-	-	-	-	-	-	-
Initial value:	0	0	0	0	0	0	0	0	0	0	0	0	0	0	0	0
R/W:	R	R	R/W	R	R	R	R	R	R	R	R	R	R	R	R	R

Bit	Bit Name	Initial Value	R/W	Description
15, 14	—	All 0	R	Reserved These bits are always read as 0. The write value should always be 0.
13	ADST	0	R/W	A/D Start Starts or stops A/D conversion. When this bit is set to 1, A/D conversion is started. When this bit is cleared to 0, A/D conversion is stopped and the A/D converter enters the idle state. In single or single-cycle scan mode, this bit is automatically cleared to 0 when A/D conversion ends on the selected single channel. In continuous scan mode, A/D conversion is continuously performed for the selected channels in sequence until this bit is cleared by software, reset, or in software standby mode or module standby mode.
12 to 0	—	All 0	R	Reserved These bits are always read as 0. The write value should always be 0.

Table 15.3 Channel Select List

- Single Mode

			Analog Input Channels		
Bit 2	Bit 1	Bit 0	Single Mode		
CH2	CH1	CH0	A/D_0	A/D_1	A/D_2
0	0	0	AN0	AN4	AN8
		1	Setting prohibited	Setting prohibited	AN9
	1	0	AN2	AN6	AN10
		1	Setting prohibited	Setting prohibited	AN11
1	0	0			AN12
		1			AN13
	1	0			AN14
		1			AN15

- 2-Channel Scan Mode

			Analog Input Channels							
Bit 2	Bit 1	Bit 0	Software Activation			Other than Software Activation				
			A/D_0	A/D_1	A/D_2	A/D_0		A/D_1		A/D_2
CH2	CH1	CH0	A/D_0	A/D_1	A/D_2	Group 0	Group 1	Group 0	Group 1	A/D_2
0	0	0	AN0	AN4	Setting prohibited	AN0	AN2	AN4	AN6	Setting prohibited
		1	Setting prohibited	Setting prohibited		Setting prohibited	Setting prohibited	Setting prohibited	Setting prohibited	
	1	0	AN2	AN6						
		1	Setting prohibited	Setting prohibited						
1	0	0								
		1								
	1	0								
		1								

Note: When 2-, 4-, or 8-channel scan mode has been selected, the channels for operation are selected only by bits CH2 to CH0. For example, when 8-channel scan mode has been selected with continuous scan mode, continuous conversion will be performed on AN8 if bits CH2 to CH0 have been set to 000.

- 4-Channel Scan Mode

			Analog Input Channels		
Bit 2	Bit 1	Bit 0	4-Channel Scan Mode*		
CH2	CH1	CH0	A/D_0	A/D_1	A/D_2
0	0	0	AN0	AN4	AN8
		1	Setting prohibited	Setting prohibited	AN8, AN9
		0			AN8 to AN10
	1	0			AN8 to AN11
1	0	0			AN12
		1			AN12, AN13
		0			AN12 to AN14
	1	0			AN12 to AN15

Note: * Continuous scan mode or single-scan mode can be selected with the ADCS bit. When 2-, 4-, or 8-channel scan mode has been selected, the channels for operation are selected only by bits CH2 to CH0. For example, when 8-channel scan mode has been selected with continuous scan mode, continuous conversion will be performed on AN8 if bits CH2 to CH0 have been set to 000.

- 8-Channel Scan Mode

			Analog Input Channels
Bit 2	Bit 1	Bit 0	8-Channel Scan Mode*
CH2	CH1	CH0	A/D_2
0	0	0	AN8
		1	AN8, AN9
		0	AN8 to AN10
	1	0	AN8 to AN11
1	0	0	AN8 to AN12
		1	AN8 to AN13
		0	AN8 to AN14
	1	0	AN8 to AN15

Note: * Continuous scan mode or single-scan mode can be selected with the ADCS bit. When 2-, 4-, or 8-channel scan mode has been selected, the channels for operation are selected only by bits CH2 to CH0. For example, when 8-channel scan mode has been selected with continuous scan mode, continuous conversion will be performed on AN8 if bits CH2 to CH0 have been set to 000.

15.3.4 A/D Trigger Select Registers_0 and _1 (ADTSR_0 and ADTSR_1)

The ADTSR enables an A/D conversion started by an external trigger signal.

In particular, the two channels in A/D module 0 and A/D module 1 are divided into two groups (group 0 and group 1) and the A/D trigger can be specified for each group independently in 2-channel scan mode.

- ADTSR_0

Bit:	15	14	13	12	11	10	9	8	7	6	5	4	3	2	1	0
	TRG11S[3:0]				TRG01S[3:0]				TRG1S[3:0]				TRG0S[3:0]			
Initial value:	0	0	0	0	0	0	0	0	0	0	0	0	0	0	0	0
R/W:	R/W	R/W	R/W	R/W	R/W	R/W	R/W	R/W	R/W	R/W	R/W	R/W	R/W	R/W	R/W	R/W

Bit	Bit Name	Initial Value	R/W	Description
15 to 12	TRG11S[3:0]	0000	R/W	<p>A/D Trigger 1 Group 1 Select 3 to 0</p> <p>Select an external trigger, MTU2 trigger, or MTU2S trigger to start A/D conversion for group 1 when A/D module 1 is in 2-channel scan mode.</p> <p>0000: External trigger pin ($\overline{\text{ADTRG}}$) input</p> <p>0001: TGRA input capture/compare match for each MTU2 channel or TCNT_4 trough in complementary PWM mode (TRGAN)</p> <p>0010: MTU2 CH0 compare match (TRG0N)</p> <p>0011: MTU2 A/D conversion start request delaying (TRG4AN)</p> <p>0100: MTU2 A/D conversion start request delaying (TRG4BN)</p> <p>0101: TGRA input capture/compare match on each MTU2S channel or TCNT_4 trough in complementary PWM mode (TRGAN)</p> <p>0110: Setting prohibited</p> <p>0111: MTU2S A/D conversion start request delaying (TRG4AN)</p> <p>1000: MTU2S A/D conversion start request delaying (TRG4BN)</p> <p>1001: Setting prohibited</p> <p>101x: Setting prohibited</p> <p>11xx: Setting prohibited</p> <p>When switching the selector, first clear the ADST bit in the A/D control register (ADCR) to 0.</p> <p>Specify different trigger sources for the group 0 and group 1 conversion requests so that a group 0 conversion request is not generated simultaneously with a group 1 conversion request in 2-channel scan mode.</p>

Bit	Bit Name	Initial Value	R/W	Description
11 to 8	TRG01S[3:0]	0000	R/W	<p>A/D Trigger 0 Group 1 Select 3 to 0</p> <p>Select an external trigger, MTU2 trigger, or MTU2S trigger to start A/D conversion for group 1 when A/D module 0 is in 2-channel scan mode.</p> <p>0000: External trigger pin ($\overline{\text{ADTRG}}$) input</p> <p>0001: TGRA input capture/compare match for each MTU2 channel or TCNT_4 trough in complementary PWM mode (TRGAN)</p> <p>0010: MTU2 CH0 compare match (TRG0N)</p> <p>0011: MTU2 A/D conversion start request delaying (TRG4AN)</p> <p>0100: MTU2 A/D conversion start request delaying (TRG4BN)</p> <p>0101: TGRA input capture/compare match on each MTU2S channel or TCNT_4 trough in complementary PWM mode (TRGAN)</p> <p>0110: Setting prohibited</p> <p>0111: MTU2S A/D conversion start request delaying (TRG4AN)</p> <p>1000: MTU2S A/D conversion start request delaying (TRG4BN)</p> <p>1001: Setting prohibited</p> <p>101x: Setting prohibited</p> <p>11xx: Setting prohibited</p> <p>When switching the selector, first clear the ADST bit in the A/D control register (ADCR) to 0.</p> <p>Specify different trigger sources for the group 0 and group 1 conversion requests so that a group 0 conversion request is not generated simultaneously with a group 1 conversion request in 2-channel scan mode.</p>

Bit	Bit Name	Initial Value	R/W	Description
7 to 4	TRG1S[3:0]	0000	R/W	<p>A/D Trigger 1 Select 3 to 0</p> <p>Select an external trigger, MTU2 trigger, or MTU2S trigger to start A/D conversion for A/D module 1. In 2-channel scan mode, these bits select an external trigger, MTU2 trigger, or MTU2S trigger to start A/D conversion for group 0.</p> <p>0000: External trigger pin ($\overline{\text{ADTRG}}$) input</p> <p>0001: TGRA input capture/compare match for each MTU2 channel or TCNT_4 trough in complementary PWM mode (TRGAN)</p> <p>0010: MTU2 CH0 compare match (TRG0N)</p> <p>0011: MTU2 A/D conversion start request delaying (TRG4AN)</p> <p>0100: MTU2 A/D conversion start request delaying (TRG4BN)</p> <p>0101: TGRA input capture/compare match on each MTU2S channel or TCNT_4 trough in complementary PWM mode (TRGAN)</p> <p>0110: Setting prohibited</p> <p>0111: MTU2S A/D conversion start request delaying (TRG4AN)</p> <p>1000: MTU2S A/D conversion start request delaying (TRG4BN)</p> <p>1001: Setting prohibited</p> <p>101x: Setting prohibited</p> <p>11xx: Setting prohibited</p> <p>When switching the selector, first clear the ADST bit in the A/D control register (ADCR) to 0.</p> <p>Specify different trigger sources for the group 0 and group 1 conversion requests so that a group 0 conversion request is not generated simultaneously with a group 1 conversion request in 2-channel scan mode.</p>

Bit	Bit Name	Initial Value	R/W	Description
3 to 0	TRG0S[3:0]	0000	R/W	<p>A/D Trigger 0 Select 3 to 0</p> <p>Select an external trigger, MTU2 trigger, or MTU2S trigger to start A/D conversion for A/D module 0. In 2-channel scan mode, these bits select an external trigger, MTU2 trigger, or MTU2S trigger to start A/D conversion for group 0.</p> <p>0000: External trigger pin (\overline{ADTRG}) input</p> <p>0001: TGRA input capture/compare match for each MTU2 channel or TCNT_4 trough in complementary PWM mode (TRGAN)</p> <p>0010: MTU2 CH0 compare match (TRG0N)</p> <p>0011: MTU2 A/D conversion start request delaying (TRG4AN)</p> <p>0100: MTU2 A/D conversion start request delaying (TRG4BN)</p> <p>0101: TGRA input capture/compare match on each MTU2S channel or TCNT_4 trough in complementary PWM mode (TRGAN)</p> <p>0110: Setting prohibited</p> <p>0111: MTU2S A/D conversion start request delaying (TRG4AN)</p> <p>1000: MTU2S A/D conversion start request delaying (TRG4BN)</p> <p>1001: Setting prohibited</p> <p>101x: Setting prohibited</p> <p>11xx: Setting prohibited</p> <p>When switching the selector, first clear the ADST bit in the A/D control register (ADCR) to 0.</p> <p>Specify different trigger sources for the group 0 and group 1 conversion requests so that a group 0 conversion request is not generated simultaneously with a group 1 conversion request in 2-channel scan mode.</p>

[Legend]

x: Don't care

- ADTSR_1

Bit:	15	14	13	12	11	10	9	8	7	6	5	4	3	2	1	0
	TRG2S[3:0]				-	-	-	-	-	-	-	-	-	-	-	-
Initial value:	0	0	0	0	0	0	0	0	0	0	0	0	0	0	0	0
R/W:	R/W	R/W	R/W	R/W	R	R	R	R	R	R	R	R	R	R	R	R

Bit	Bit Name	Initial Value	R/W	Description
15 to 12	TRG2S[3:0]	0000	R/W	<p>A/D Trigger 2 Select 3 to 0</p> <p>Select an external trigger, MTU2 trigger, or MTU2S trigger to start A/D conversion for A/D module 2.</p> <p>0000: External trigger pin ($\overline{\text{ADTRG}}$) input</p> <p>0001: TGRA input capture/compare match for each MTU2 channel or TCNT_4 trough in complementary PWM mode (TRGAN)</p> <p>0010: MTU2 CH0 compare match (TRG0N)</p> <p>0011: MTU2 A/D conversion start request delaying (TRG4AN)</p> <p>0100: MTU2 A/D conversion start request delaying (TRG4BN)</p> <p>0101: TGRA input capture/compare match on each MTU2S channel or TCNT_4 trough in complementary PWM mode (TRGAN)</p> <p>0110: Setting prohibited</p> <p>0111: MTU2S A/D conversion start request delaying (TRG4AN)</p> <p>1000: MTU2S A/D conversion start request delaying (TRG4BN)</p> <p>1001: Setting prohibited</p> <p>101x: Setting prohibited</p> <p>11xx: Setting prohibited</p> <p>When switching the selector, first clear the ADST bit in the A/D control register (ADCR) to 0.</p>
11 to 0	—	All 0	R	<p>Reserved</p> <p>These bits are always read as 0. The write value should always be 0.</p>

[Legend]

x: Don't care

15.4 Operation

The A/D converter operates by successive approximation with 10-bit resolution. It has two operating modes; single mode and scan mode. There are two kinds of scan mode: continuous mode and single-cycle mode. When changing the operating mode or analog input channel, in order to prevent incorrect operation, first clear the ADST bit to 0 in ADCR.

15.4.1 Single Mode

In single mode, A/D conversion is to be performed only once on the specified single channel. The operations are as follows.

1. A/D conversion is started when the ADST bit in ADCR is set to 1, according to software, MTU2, MTU2S, or external trigger input.
2. When A/D conversion is completed, the result is transferred to the A/D data register corresponding to the channel.
3. On completion of conversion, the ADF bit in ADCR is set to 1. If the ADIE bit is set to 1 at this time, an ADI interrupt request is generated.
4. The ADST bit remains set to 1 during A/D conversion. When A/D conversion ends, the ADST bit is automatically cleared to 0 and the A/D converter enters the idle state. When the ADST bit is cleared to 0 during A/D conversion, A/D conversion stops and the A/D converter enters the idle state.

15.4.2 Continuous Scan Mode

In continuous scan mode, A/D conversion is to be performed sequentially on the specified channels (up to eight channels).

1. When the ADST bit in ADCR is set to 1 by software, MTU2, MTU2S, or external trigger input, A/D conversion starts on the channel with the lowest number in the group (AN8, AN9, ..., AN15).
2. When A/D conversion for each channel is completed, the result is sequentially transferred to the A/D data register corresponding to each channel.
3. When conversion of all the selected channels is completed, the ADF bit in ADCSR is set to 1. If the ADIE bit is set to 1 at this time, an ADI interrupt is requested after A/D conversion ends. Conversion of the first channel in the group starts again.
4. Steps 2 to 3 are repeated as long as the ADST bit remains set to 1. When the ADST bit is cleared to 0, A/D conversion stops and the A/D converter enters the idle state.

15.4.3 Single-Cycle Scan Mode

In single-cycle scan mode, A/D conversion is to be performed once on the specified channels (up to eight channels).

1. When the ADST bit in ADCR is set to 1 by a software, MTU2, MTU2S, or external trigger input, A/D conversion starts on the channel with the lowest number in the group (AN8, AN9, ..., AN15).
2. When A/D conversion for each channel is completed, the result is sequentially transferred to the A/D data register corresponding to each channel.
3. When conversion of all the selected channels is completed, the ADF bit in ADCSR is set to 1. If the ADIE bit is set to 1 at this time, an ADI interrupt is requested after A/D conversion ends.
4. After A/D conversion ends, the ADST bit is automatically cleared to 0 and the A/D converter enters the idle state. When the ADST bit is cleared to 0 during A/D conversion, A/D conversion stops and the A/D converter enters the idle state.

15.4.4 Input Sampling and A/D Conversion Time

The A/D converter has a built-in sample-and-hold circuit for each module. The A/D converter samples the analog input when the A/D conversion start delay time (t_D) has passed after the ADST bit in ADCR is set to 1, then starts conversion. Figure 15.2 shows the A/D conversion timing. Table 15.4 shows the A/D conversion time.

As indicated in figure 15.2, the A/D conversion time (t_{CONV}) includes t_D and the input sampling time (t_{SPL}). The length of t_D varies depending on the timing of the write access to ADCR. The total conversion time therefore varies within the ranges indicated in table 15.4.

In scan mode, the values given in table 15.4 apply to the first conversion time. The values given in table 15.5 apply to the second and subsequent conversions.

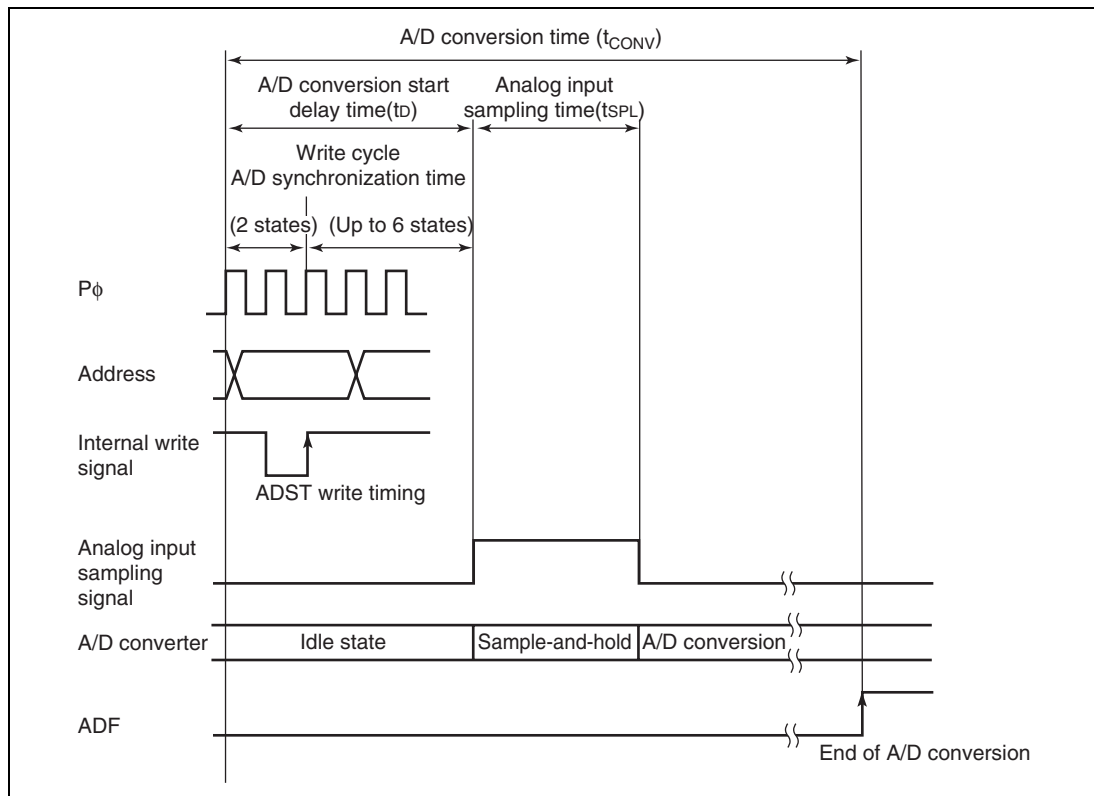

Figure 15.2 A/D Conversion Timing

Table 15.4 A/D Conversion Time (Single Mode)

		STC = 0											
		CKSL1 = 0						CKSL1 = 1					
		CKSL0 = 0			CKSL0 = 1			CKSL0 = 0			CKSL0 = 1		
Item	Symbol	Min.	Typ.	Max.	Min.	Typ.	Max.	Min.	Typ.	Max.	Min.	Typ.	Max.
A/D conversion start delay time	t_d	2	—	6	2	—	5	2	—	4	2	—	3
Input sampling time	t_{SPL}	—	24	—	—	18	—	—	12	—	—	6	—
A/D conversion time	t_{CONV}	202	—	206	152	—	155	102	—	104	52	—	53

		STC = 1											
		CKSL1 = 0						CKSL1 = 1					
		CKSL0 = 0			CKSL0 = 1			CKSL0 = 0			CKSL0 = 1		
Item	Symbol	Min.	Typ.	Max.	Min.	Typ.	Max.	Min.	Typ.	Max.	Min.	Typ.	Max.
A/D conversion start delay time	t_d	2	—	6	2	—	5	2	—	4	2	—	3
Input sampling time	t_{SPL}	—	36	—	—	27	—	—	18	—	—	9	—
A/D conversion time	t_{CONV}	258	—	262	194	—	197	130	—	132	66	—	67

Note: All values represent the number of states for $P\phi$.

Table 15.5 A/D Conversion Time (Scan Mode)

STC	CKSL1	CKSL0	Conversion Time (State)	Conversion Time Calculation Example	
				$P\phi = 25 \text{ MHz}$	$P\phi = 40 \text{ MHz}$
0	0	0	200 (Fixed)	8 μs	5 μs
		1	150 (Fixed)	6 μs	3.8 μs
	1	0	100 (Fixed)	4 μs	2.5 μs
		1	50 (Fixed)	2 μs	Setting prohibited
1	0	0	256 (Fixed)	10.2 μs	6.4 μs
		1	192 (Fixed)	7.7 μs	4.8 μs
	1	0	128 (Fixed)	5.1 μs	3.2 μs
		1	64 (Fixed)	2.6 μs	Setting prohibited

15.4.5 A/D Converter Activation by MTU2 or MTU2S

The A/D converter can be independently activated by an A/D conversion request from the interval timer of the MTU2 or MTU2S.

To activate the A/D converter by the MTU2 or MTU2S, first set the TRGE bit in the A/D control/status register (ADCSR) to 1, and then set the A/D trigger select register (ADTSR). After this register setting has been made, the ADST bit in ADCR is automatically set to 1 when an A/D conversion request from the interval timer of the MTU2 or MTU2S occurs. The timing from setting of the ADST bit until the start of A/D conversion is the same as when 1 is written to the ADST bit by software.

15.4.6 External Trigger Input Timing

A/D conversion can be externally triggered. When the TRGE bit in the A/D control/status register (ADCSR) is set to 1 while the A/D trigger select registers_0 and _1 (ADTSR_0 and ADTSR_1) are set to external trigger pin input, external trigger input is enabled at the $\overline{\text{ADTRG}}$ pin. A falling edge of the $\overline{\text{ADTRG}}$ pin sets the ADST bit to 1 in ADCR, starting A/D conversion. Other operations, in both single and scan modes, are the same as when the ADST bit has been set to 1 by software. Figure 15.3 shows the timing.

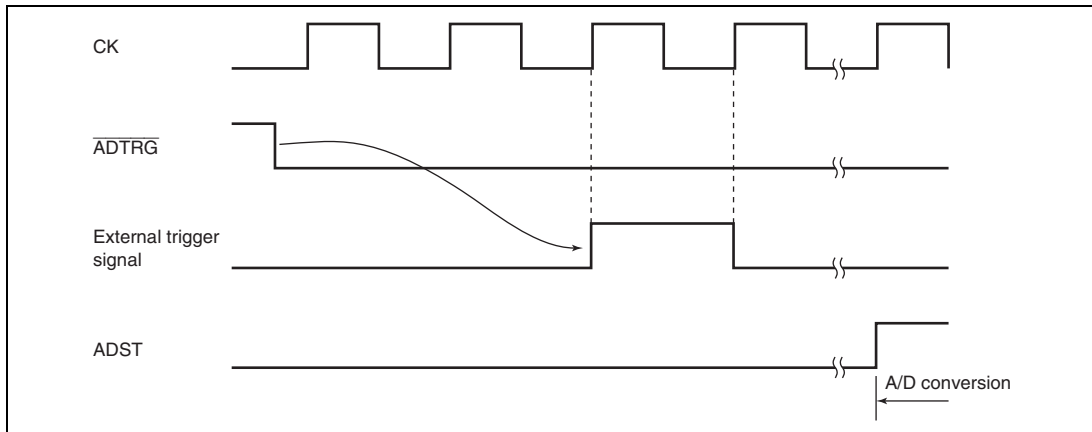

Figure 15.3 External Trigger Input Timing

15.4.7 2-Channel Scanning

In 2-channel scan mode, since the two channels of analog input are divided into groups 0 and 1, triggers for activation of groups 0 and 1 are independently specifiable. Conversion end interrupts in 2-channel scan mode can be generated either on completion of group 0 or group 1 or on completion of group 0 and group 1. If conversion is to be started by triggers, the different sources for groups 0 and 1 are specified in ADTSR. A request for conversion by group 1 generated during conversion by group 0 is ignored. Figure 15.4 shows an example of operation when TRG4AN of the MTU2 has been specified as the A/D conversion start request by group 0 and TRG4BN of the MTU2 has been specified as the A/D conversion start request by group 1.

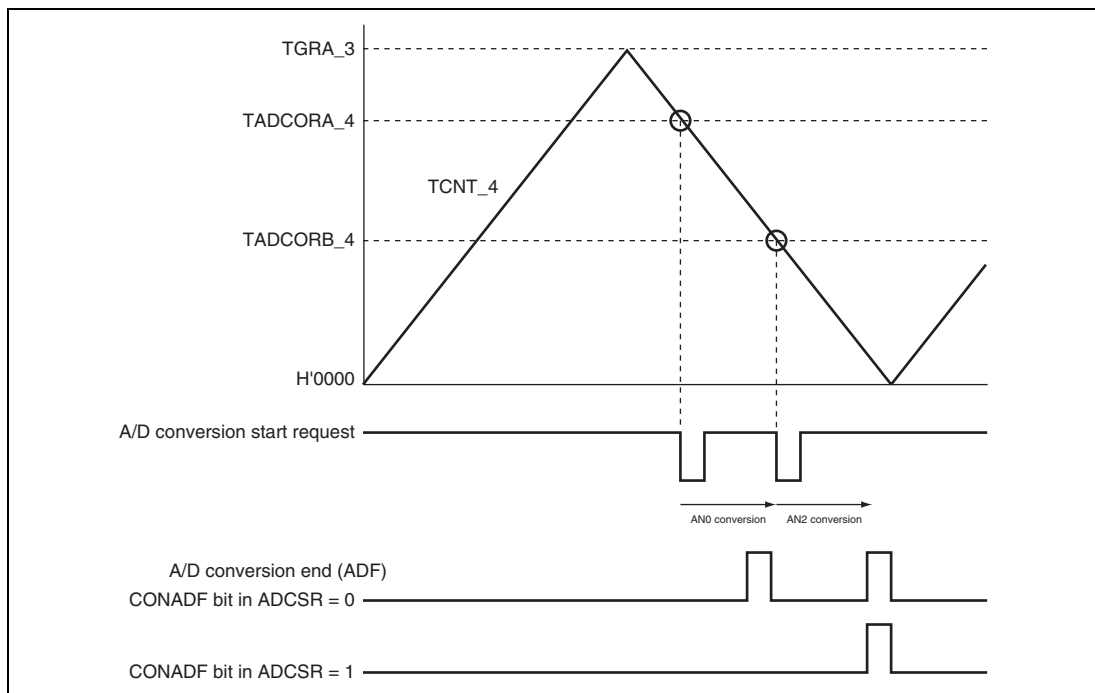

Figure 15.4 Example of 2-Channel Scanning

15.5 Interrupt Sources and DTC Transfer Request

The A/D converter can generate an A/D conversion end interrupt request (ADI). The ADI interrupt can be enabled by setting the ADIE bit in the A/D control/status register (ADCSR) to 1, or disabled by clearing the ADIE bit to 0.

The DTC can be activated by an ADI interrupt. In this case an interrupt request is not sent to the CPU.

When the DTC is activated by an ADI interrupt, the ADF bit in ADCSR is automatically cleared when data is transferred by the DTC. Having the converted data read by the DTC in response to an ADI interrupt enables continuous conversion to be achieved without imposing a load on software.

Table 15.6 A/D Converter Interrupt Source

Name	Interrupt Source	Interrupt Source Flag	DTC Activation
ADI0	A/D_0 conversion completed	ADF in ADCSR_0	Possible
ADI1	A/D_1 conversion completed	ADF in ADCSR_1	Possible
ADI2	A/D_2 conversion completed	ADF in ADCSR_2	Possible

15.6 Definitions of A/D Conversion Accuracy

This LSI's A/D conversion accuracy definitions are given below.

- Resolution
The number of A/D converter digital output codes
- Quantization error
The deviation inherent in the A/D converter, given by 1/2 LSB (see figure 15.5).
- Offset error
The deviation of the analog input voltage value from the ideal A/D conversion characteristic when the digital output changes from the minimum voltage value B'000000000 (H'000) to B'000000001 (H'001) (see figure 15.6).
- Full-scale error
The deviation of the analog input voltage value from the ideal A/D conversion characteristic when the digital output changes from B'111111110 (H'3FE) to B'111111111 (H'3FF) (see figure 15.6).
- Nonlinearity error
The error with respect to the ideal A/D conversion characteristic between zero voltage and full-scale voltage. Does not include offset error, full-scale error, or quantization error (see figure 15.6).
- Absolute accuracy
The deviation between the digital value and the analog input value. Includes offset error, full-scale error, quantization error, and nonlinearity error.

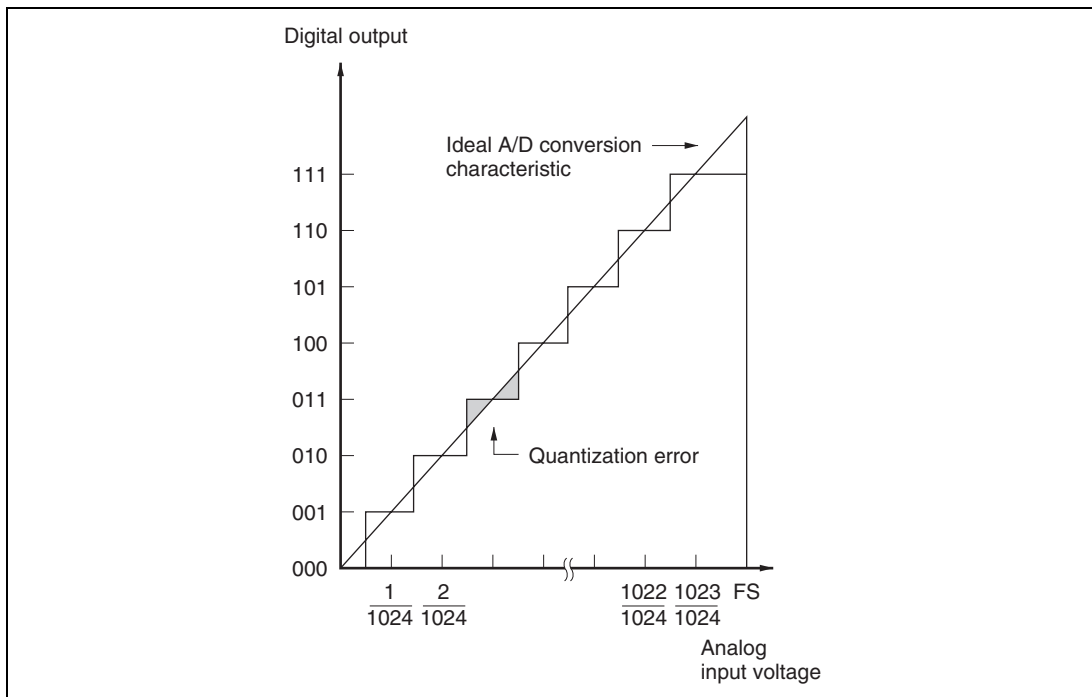

Figure 15.5 Definitions of A/D Conversion Accuracy

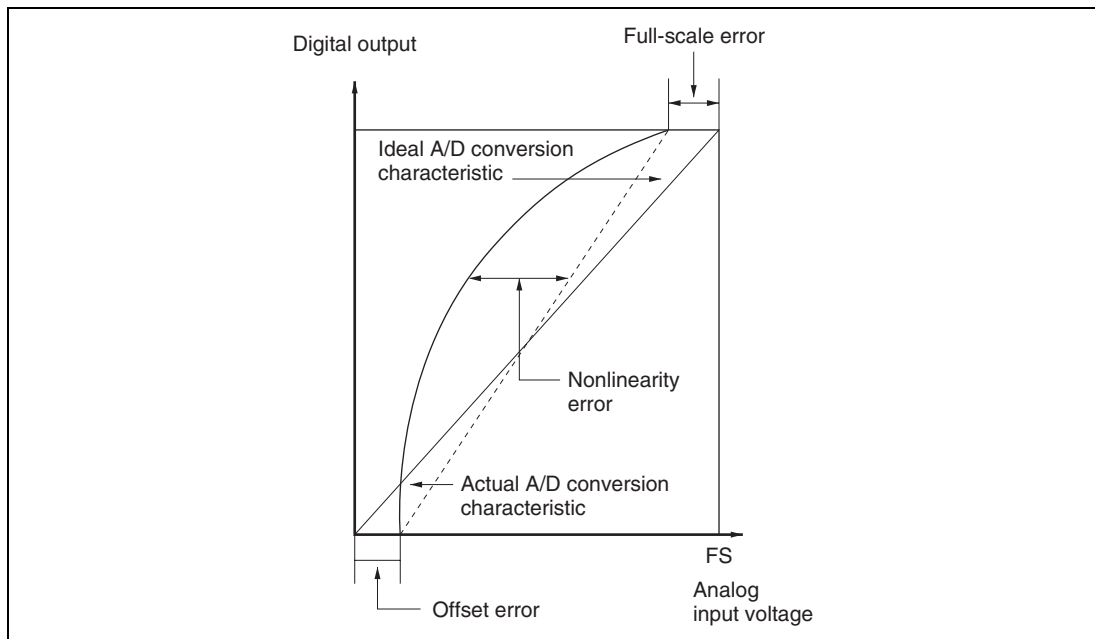

Figure 15.6 Definitions of A/D Conversion Accuracy

15.7 Usage Notes

15.7.1 Module Standby Mode Setting

Operation of the A/D converter can be disabled or enabled using the standby control register. The initial setting is for operation of the A/D converter to be halted. Register access is enabled by clearing module standby mode. For details, refer to section 22, Power-Down Modes.

15.7.2 Permissible Signal Source Impedance

This LSI's analog input is designed such that conversion accuracy is guaranteed for an input signal for which the signal source impedance is 1 k Ω or less. This specification is provided to enable the A/D converter's sample-and-hold circuit input capacitance to be charged within the sampling time; if the sensor output impedance exceeds 1 k Ω , charging may be insufficient and it may not be possible to guarantee A/D conversion accuracy. However, for A/D conversion in single mode with a large capacitance provided externally, the input load will essentially comprise only the internal input resistance of 10 k Ω , and the signal source impedance is ignored. However, as a low-pass filter effect is obtained in this case, it may not be possible to follow an analog signal with a large differential coefficient (e.g., 5 mV/ μ s or greater) (see figure 15.7). When converting a high-speed analog signal or converting in scan mode, a low-impedance buffer should be inserted.

15.7.3 Influences on Absolute Accuracy

Adding capacitance results in coupling with GND, and therefore noise in GND may adversely affect absolute precision. Be sure to make the connection to an electrically stable GND such as AVss.

Care is also required to insure that filter circuits do not interfere in the accuracy by the printed circuit digital signals on the mounting board (i.e, acting as antennas).

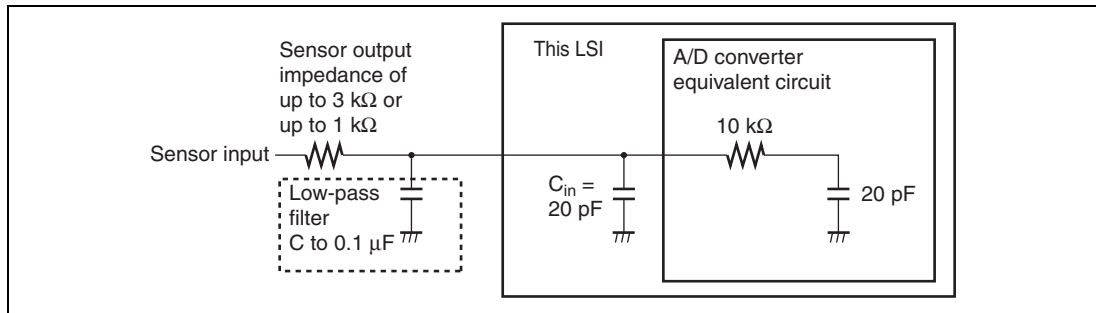

Figure 15.7 Example of Analog Input Circuit

15.7.4 Range of Analog Power Supply and Other Pin Settings

If the conditions below are not met, the reliability of the device may be adversely affected.

- Analog input voltage range
The voltage applied to analog input pin AN_n during A/D conversion should be in the range $AV_{SS} \leq VAN \leq AV_{CC}$.
- Relationship between AV_{CC}, AV_{SS} and V_{CC}, V_{SS}
Set $AV_{SS} = V_{SS}$ for the relationship between AV_{CC}, AV_{SS} and V_{CC}, V_{SS}. If the A/D converter is not used, the AV_{CC} and AV_{SS} pins must not be left open.

15.7.5 Notes on Board Design

In board design, digital circuitry and analog circuitry should be as mutually isolated as possible, and layout in which digital circuit signal lines and analog circuit signal lines cross or are in close proximity should be avoided as far as possible. Failure to do so may result in incorrect operation of the analog circuitry due to inductance, adversely affecting A/D conversion values. Also, digital circuitry must be isolated from the analog input signals (AN₀ to AN₁₅), and analog power supply (AV_{CC}) by the analog ground (AV_{SS}). Also, the analog ground (AV_{SS}) should be connected at one point to a stable ground (V_{SS}) on the board.

15.7.6 Notes on Noise Countermeasures

A protection circuit should be connected in order to prevent damage due to abnormal voltage, such as an excessive surge at the analog input pins (AN0 to AN15), between AVcc and AVss, as shown in figure 15.8. Also, the bypass capacitors connected to AVcc and the filter capacitor connected to AN0 to AN15 must be connected to AVss.

If a filter capacitor is connected, the input currents at the analog input pins (AN0 to AN15) are averaged, and so an error may arise. Also, when A/D conversion is performed frequently, as in scan mode, if the current charged and discharged by the capacitance of the sample-and-hold circuit in the A/D converter exceeds the current input via the input impedance (R_{in}), an error will arise in the analog input pin voltage. Careful consideration is therefore required when deciding circuit constants.

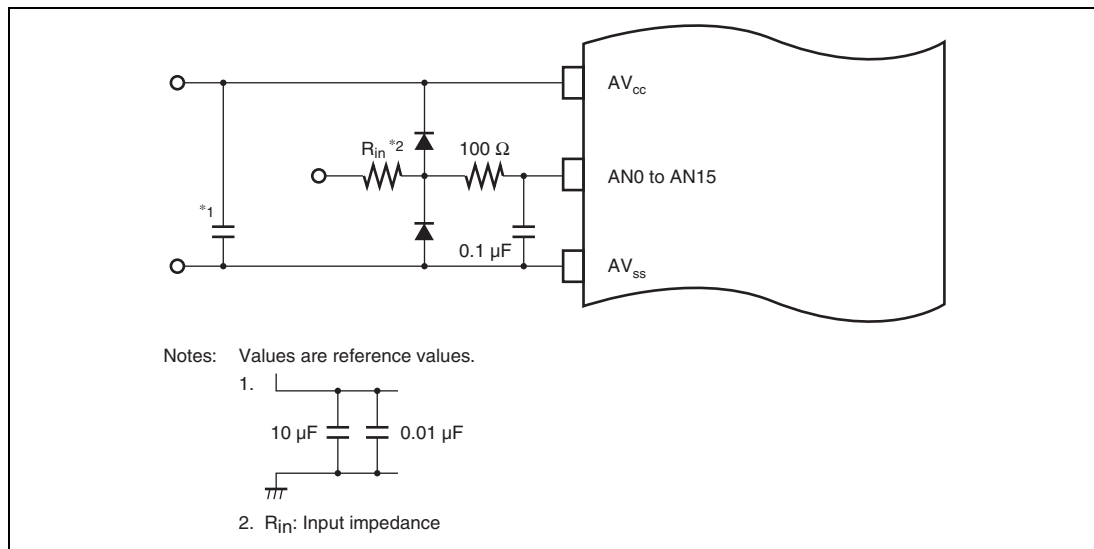

Figure 15.8 Example of Analog Input Protection Circuit

Table 15.7 Analog Pin Specifications

Item	Min.	Max.	Unit	Condition
Analog input capacitance	—	20	pF	—
Permissible signal source impedance	—	3	k Ω	$P_{\phi} \leq 20$ MHz
		1		$P_{\phi} > 20$ MHz

Section 16 Compare Match Timer (CMT)

This LSI has an on-chip compare match timer (CMT) consisting of a 2-channel 16-bit timer. The CMT has a 16-bit counter, and can generate interrupts at set intervals.

16.1 Features

- Selection of four counter input clocks
Any of four internal clocks ($P\phi/8$, $P\phi/32$, $P\phi/128$, and $P\phi/512$) can be selected independently for each channel.
- Interrupt request on compare match
- Module standby mode can be set.

Figure 16.1 shows a block diagram of CMT.

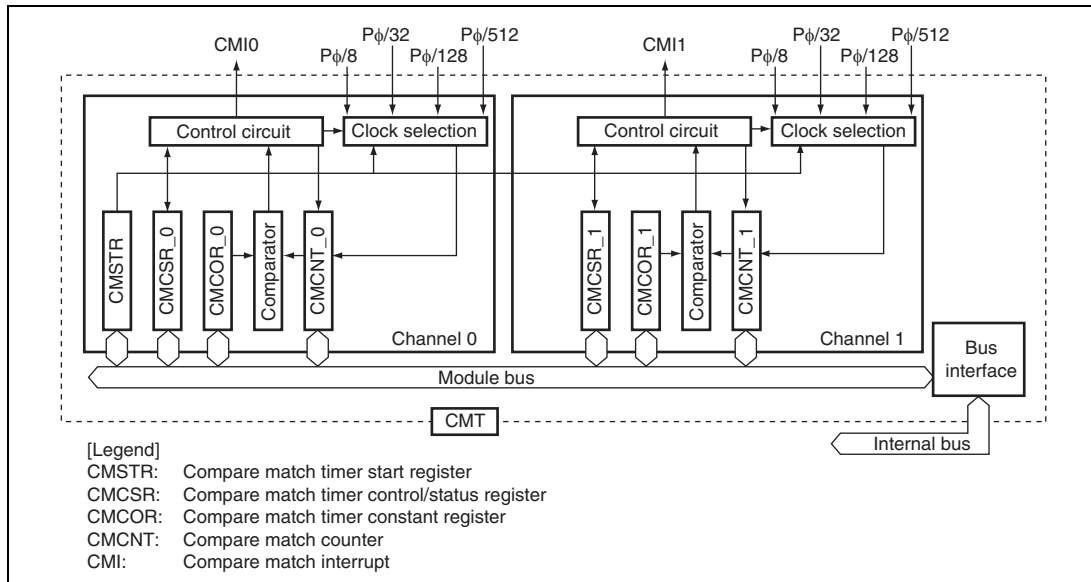

Figure 16.1 Block Diagram of CMT

16.2 Register Descriptions

The CMT has the following registers. For details on register addresses and register states during each processing, refer to section 23, List of Registers. To distinguish registers in each channel, an underscore and the channel number are added as a suffix to the register name.

Table 16.1 Register Configuration

Register Name	Abbreviation	R/W	Initial Value	Address	Access Size
Compare match timer start register	CMSTR	R/W	H'0000	H'FFFFCE00	8, 16, 32
Compare match timer control/status register_1	CMCSR_0	R/W	H'0000	H'FFFFCE02	8, 16
Compare match counter_0	CMCNT_0	R/W	H'0000	H'FFFFCE04	8, 16, 32
Compare match constant register_0	CMCOR_0	R/W	H'FFFF	H'FFFFCE06	8, 16
Compare match timer control/status register_0	CMCSR_1	R/W	H'0000	H'FFFFCE08	8, 16, 32
Compare match counter_1	CMCNT_1	R/W	H'0000	H'FFFFCE0A	8, 16
Compare match constant register_1	CMCOR_1	R/W	H'FFFF	H'FFFFCE0C	8, 16, 32

16.2.1 Compare Match Timer Start Register (CMSTR)

CMSTR is a 16-bit register that selects whether compare match counter (CMCNT) operates or is stopped.

Bit:	15	14	13	12	11	10	9	8	7	6	5	4	3	2	1	0
	-	-	-	-	-	-	-	-	-	-	-	-	-	-	STR1	STR0
Initial value:	0	0	0	0	0	0	0	0	0	0	0	0	0	0	0	0
R/W:	R	R	R	R	R	R	R	R	R	R	R	R	R	R	R/W	R/W

Bit	Bit Name	Initial value	R/W	Description
15 to 2	—	All 0	R	Reserved These bits are always read as 0. The write value should always be 0.
1	STR1	0	R/W	Count Start 1 Specifies whether compare match counter 1 operates or is stopped. 0: CMCNT_1 count is stopped 1: CMCNT_1 count is started
0	STR0	0	R/W	Count Start 0 Specifies whether compare match counter 0 operates or is stopped. 0: CMCNT_0 count is stopped 1: CMCNT_0 count is started

16.2.2 Compare Match Timer Control/Status Register (CMCSR)

CMCSR is a 16-bit register that indicates compare match generation, enables interrupts and selects the counter input clock.

Bit:	15	14	13	12	11	10	9	8	7	6	5	4	3	2	1	0
	-	-	-	-	-	-	-	-	CMF	CMIE	-	-	-	-	-	CKS[1:0]
Initial value:	0	0	0	0	0	0	0	0	0	0	0	0	0	0	0	0
R/W:	R	R	R	R	R	R	R	R	(R/W)*1	R/W	R	R	R	R	R/W	R/W

Note: 1. Writing 0 to this bit after reading it as 1 clears the flag and is the only allowed way.

Bit	Bit Name	Initial value	R/W	Description
15 to 8	—	All 0	R	Reserved These bits are always read as 0. The write value should always be 0.
7	CMF	0	R/(W)* ¹	Compare Match Flag Indicates whether or not the values of CMCNT and CMCOR match. 0: CMCNT and CMCOR values do not match [Clearing conditions] <ul style="list-style-type: none"> When 0 is written to this bit after reading CMF=1*² When CMT registers are accessed when the value of the DISEL bit of MRB in the DTC is 0 after activating the DTC by CMI interrupts. [Setting condition] 1: CMCNT and CMCOR values match
6	CMIE	0	R/W	Compare Match Interrupt Enable Enables or disables compare match interrupt (CMI) generation when CMCNT and CMCOR values match (CMF=1). 0: Compare match interrupt (CMI) disabled 1: Compare match interrupt (CMI) enabled
5 to 2	—	All 0	R	Reserved These bits are always read as 0. The write value should always be 0.
1, 0	CKS[1:0]	00	R/W	Clock Select 1 and 0 Select the clock to be input to CMCNT from four internal clocks obtained by dividing the peripheral operating clock (P ϕ). When the STR bit in CMSTR is set to 1, CMCNT starts counting on the clock selected with bits CKS1 and CKS0. 00: P ϕ /8 01: P ϕ /32 10: P ϕ /128 11: P ϕ /512

Notes: 1. Writing 0 to this bit after reading it as 1 clears the flag and is the only allowed way.
2. If the flag is set by another compare match before writing 0 to the bit after reading it as 1, the flag will not be cleared by writing 0 to it once. In this case, read the bit as 1 again and write 0 to it.

16.2.3 Compare Match Counter (CMCNT)

CMCNT is a 16-bit register used as an up-counter. When the counter input clock is selected with bits CKS1 and CKS0 in CMCSR and the STR bit in CMSTR is set to 1, CMCNT starts counting using the selected clock.

When the value in CMCNT and the value in compare match constant register (CMCOR) match, CMCNT is cleared to H'0000 and the CMF flag in CMCSR is set to 1.

The initial value of CMCNT is H'0000.

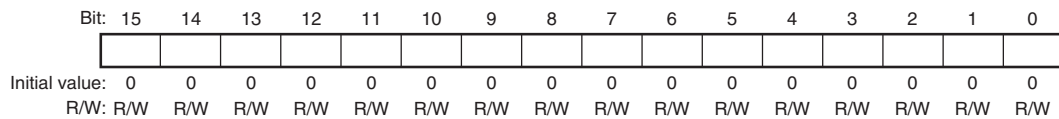

16.2.4 Compare Match Constant Register (CMCOR)

CMCOR is a 16-bit register that sets the interval up to a compare match with CMCNT.

The initial value of CMCOR is H'FFFF.

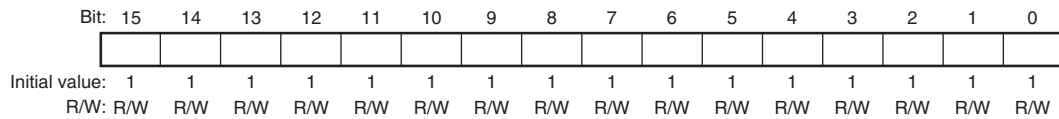

16.3 Operation

16.3.1 Interval Count Operation

When an internal clock is selected with bits CKS1 and CKS0 in CMCSR and the STR bit in CMSTR is set to 1, CMCNT starts incrementing using the selected clock. When the values in CMCNT and CMCOR match, CMCNT is cleared to H'0000 and the CMF flag in CMCSR is set to 1. When the CMIE bit in CMCSR is set to 1, a compare match interrupt (CMI) is requested. CMCNT then starts counting up again from H'0000.

Figure 16.2 shows the operation of the compare match counter.

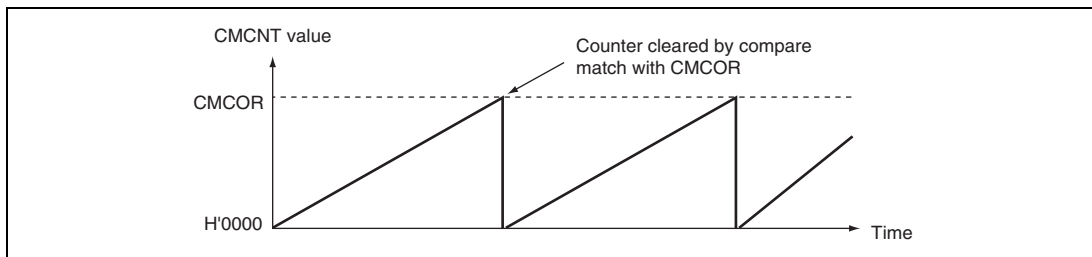

Figure 16.2 Counter Operation

16.3.2 CMCNT Count Timing

One of four internal clocks ($P\phi/8$, $P\phi/32$, $P\phi/128$, and $P\phi/512$) obtained by dividing the $P\phi$ clock can be selected with bits CKS1 and CKS0 in CMCSR. Figure 16.3 shows the timing.

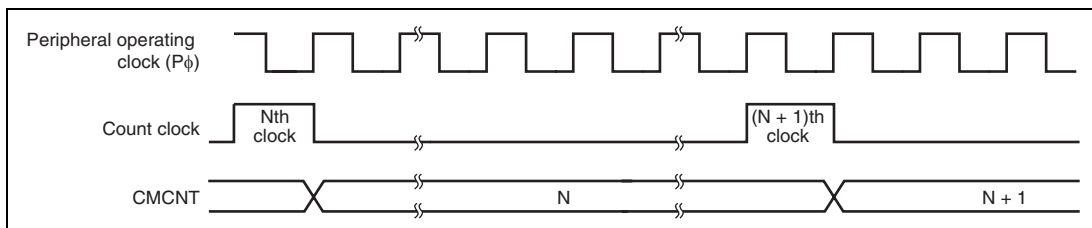

Figure 16.3 Count Timing

16.4 Interrupts

16.4.1 CMT Interrupt Sources and DTC Activation

The CMT has channels and each of them to which a different vector address is allocated has compare match interrupt. When both the interrupt request flag (CMF) and interrupt enable bit (CMIE) are set to 1, the corresponding interrupt request is output. When the interrupt is used to activate a CPU interrupt, the priority of channels can be changed by the interrupt controller settings. For details, see section 6, Interrupt Controller (INTC).

The data transfer controller (DTC) can be activated by an interrupt request. In this case, the priority between channels is fixed. See section 8, Data Transfer Controller (DTC), for details.

Table 16.2 lists the CMT interrupt sources.

Table 16.2 Interrupt Source

Channel	Interrupt Source	Interrupt Enable Bit	Interrupt Flag Bit	DTC Activation	Priority
0	CMI_0	CMIE	CMF	Possible	High
1	CMI_1	CMIE	CMF	Possible	Low

16.4.2 Timing of Setting Compare Match Flag

When CMCOR and CMCNT match, a compare match signal is generated and the CMF bit in CMCSR is set to 1. The compare match signal is generated in the last cycle in which the values match (when the CMCNT value is updated to H'0000). That is, after a match between CMCOR and CMCNT, the compare match signal is not generated until the next CMCNT counter clock input. Figure 16.4 shows the timing of CMF bit setting.

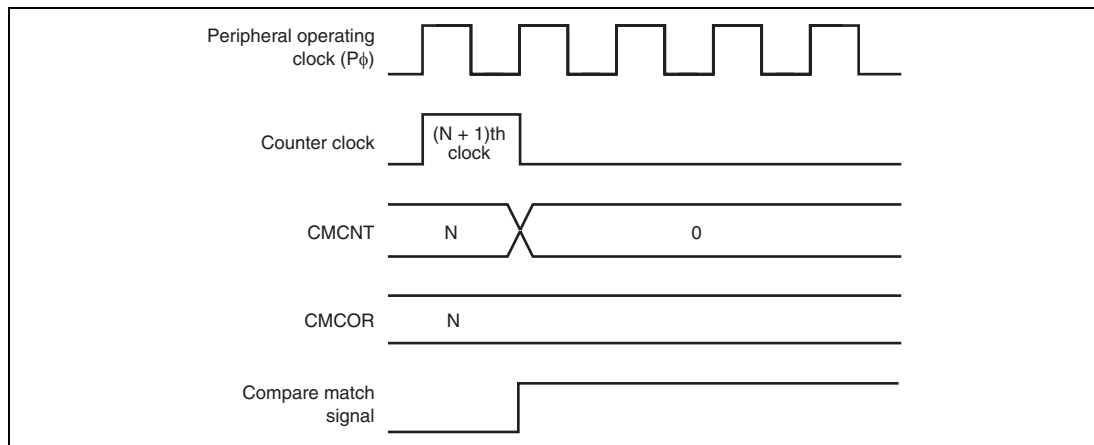

Figure 16.4 Timing of CMF Setting

16.4.3 Timing of Clearing Compare Match Flag

The CMF bit in CMCSR is cleared by reading 1 from this bit, then writing 0.

16.5 Usage Notes

16.5.1 Module Standby Mode Setting

The CMT operation can be disabled or enabled using the standby control register. The initial setting is for CMT operation to be halted. Access to a register is enabled by clearing module standby mode. For details, refer to section 22, Power-Down Modes.

16.5.2 Conflict between Write and Compare-Match Processes of CMCNT

When the compare match signal is generated in the T2 cycle while writing to CMCNT, clearing CMCNT has priority over writing to it. In this case, CMCNT is not written to. Figure 16.5 shows the timing to clear the CMCNT counter.

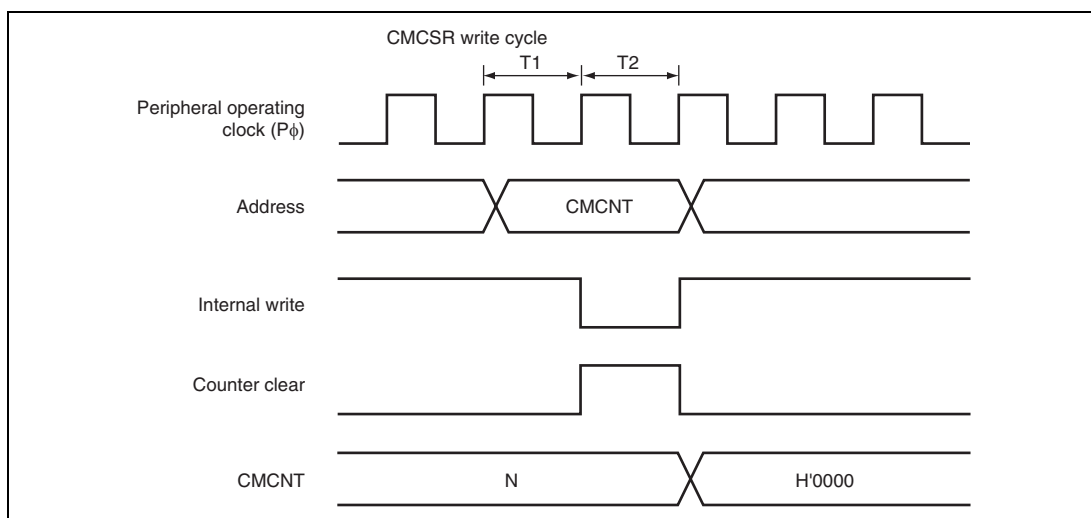

Figure 16.5 Conflict between Write and Compare-Match Processes of CMCNT

16.5.3 Conflict between Word-Write and Count-Up Processes of CMCNT

Even when the count-up occurs in the T2 cycle while writing to CMCNT in words, the writing has priority over the count-up. In this case, the count-up is not performed. Figure 16.6 shows the timing to write to CMCNT in words.

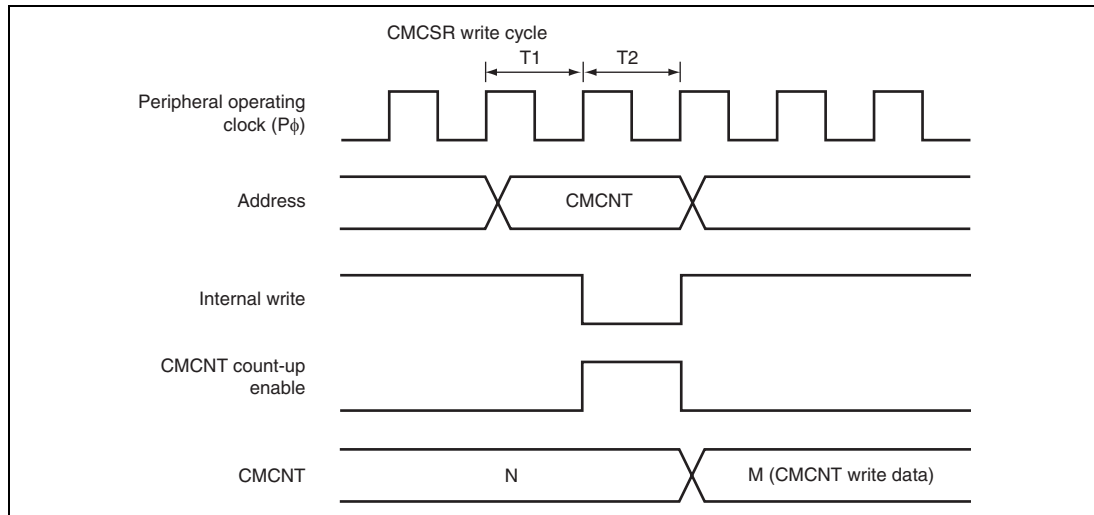

Figure 16.6 Conflict between Word-Write and Count-Up Processes of CMCNT

16.5.4 Conflict between Byte-Write and Count-Up Processes of CMCNT

Even when the count-up occurs in the T2 cycle while writing to CMCNT in bytes, the byte-writing has priority over the count-up. In this case, the count-up is not performed. The byte data on another side, which is not written to, is also not counted and the previous contents remain.

Figure 16.7 shows the timing when the count-up occurs in the T2 cycle while writing to CMCNT in bytes.

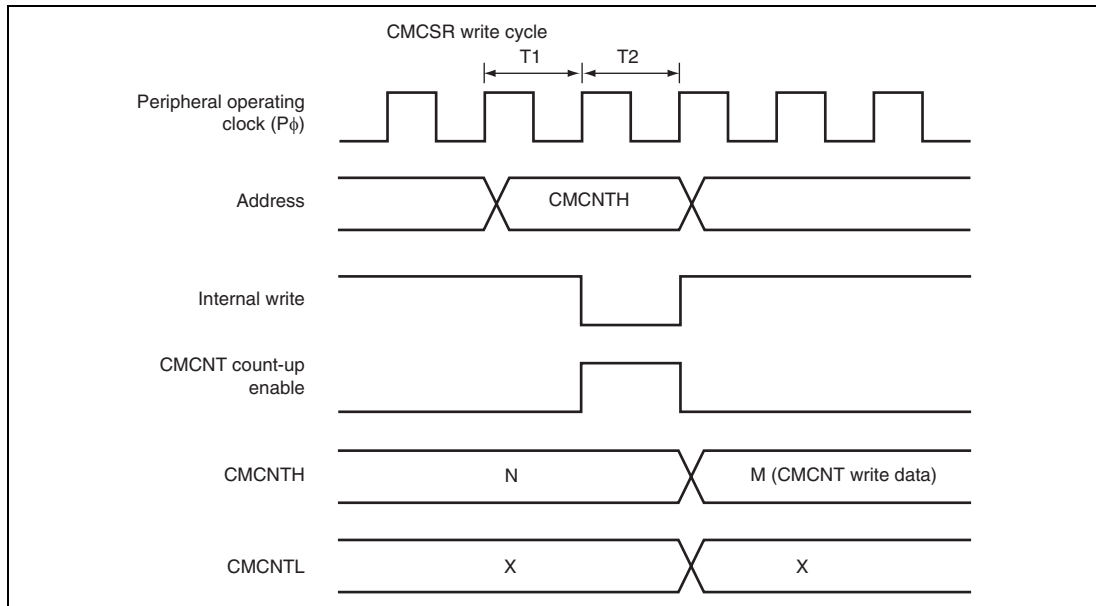

Figure 16.7 Conflict between Byte-Write and Count-Up Processes of CMCNT

16.5.5 Compare Match between CMCNT and CMCOR

Do not set the same value in CMCNT and CMCOR while CMCNT is not counting. If set, the CMF bit in CMCSR is set to 1 and CMCNT is cleared to H'0000.

Section 17 Pin Function Controller (PFC)

The pin function controller (PFC) is composed of registers that are used to select the functions of multiplexed pins and assign pins to be inputs or outputs. Tables 17.1 to 17.8 list the multiplexed pins of this LSI.

Tables 17.9 to 17.11 list the pin functions in each operating mode.

Table 17.1 SH7146 Multiplexed Pins (Port A)

Port	Function 1 (Related Module)	Function 2 (Related Module)	Function 3 (Related Module)	Function 4 (Related Module)
A	PA0 I/O (port)	$\overline{POE0}$ input (POE)	RXD0 input (SCI)	—
	PA1 I/O (port)	$\overline{POE1}$ input (POE)	TXD0 output (SCI)	—
	PA2 I/O (port)	IRQ0 input (INTC)	$\overline{POE2}$ input (POE)	SCK0 I/O (SCI)
	PA3 I/O (port)	IRQ1 input (INTC)	RXD1 input (SCI)	—
	PA4 I/O (port)	IRQ2 input (INTC)	TXD1 output (SCI)	—
	PA5 I/O (port)	IRQ3 input (INTC)	SCK1 I/O (SCI)	—
	PA6 I/O (port)	$\overline{UBCTR\overline{G}}$ output (UBC)	TCLKA input (MTU2)	$\overline{POE4}$ input (POE)
	PA7 I/O (port)	TCLKB input (MTU2)	$\overline{POE5}$ input (POE)	SCK2 I/O (SCI)
	PA8 I/O (port)	TCLKC input (MTU2)	$\overline{POE6}$ input (POE)	RXD2 input (SCI)
	PA9 I/O (port)	TCLKD input (MTU2)	$\overline{POE8}$ input (POE)	TXD2 output (SCI)
	PA10 I/O (port)	RXD0 input (SCI)	—	—
	PA11 I/O (port)	TXD0 output (SCI)	$\overline{ADTR\overline{G}}$ input (A/D)	—
	PA12 I/O (port)	SCK0 I/O (SCI)	—	—
	PA13 I/O (port)	SCK1 I/O (SCI)	—	—
	PA14 I/O (port)	RXD1 input (SCI)	—	—
	PA15 I/O (port)	TXD1 output (SCI)	—	—

Table 17.2 SH7149 Multiplexed Pins (Port A)

Port	Function 1 (Related Module)	Function 2 (Related Module)	Function 3 (Related Module)	Function 4 (Related Module)	Function 5 (Related Module)
A	PA0 I/O (port)	A0 output (BSC)	$\overline{POE0}$ input (POE)	RXD0 input (SCI)	—
	PA1 I/O (port)	A1 output (BSC)	$\overline{POE1}$ input (POE)	TXD0 output (SCI)	—
	PA2 I/O (port)	A2 output (BSC)	IRQ0 input (INTC)	$\overline{POE2}$ input (POE)	SCK0 I/O (SCI)
	PA3 I/O (port)	A3 output (BSC)	IRQ1 input (INTC)	RXD1 input (SCI)	—
	PA4 I/O (port)	A4 output (BSC)	IRQ2 input (INTC)	TXD1 output (SCI)	—
	PA5 I/O (port)	A5 output (BSC)	IRQ3 input (INTC)	SCK1 I/O (SCI)	—
	PA6 I/O (port)	\overline{RD} output (BSC)	$\overline{UBCTR\overline{G}}$ output (UBC)	TCLKA input (MTU2)	$\overline{POE4}$ input (POE)
	PA7 I/O (port)	\overline{WRH} output (BSC)	TCLKB input (MTU2)	$\overline{POE5}$ input (POE)	SCK2 I/O (SCI)
	PA8 I/O (port)	\overline{WRL} output (BSC)	TCLKC input (MTU2)	$\overline{POE6}$ input (POE)	RXD2 input (SCI)
	PA9 I/O (port)	\overline{WAIT} input (BSC)	TCLKD input (MTU2)	$\overline{POE8}$ input (POE)	TXD2 output (SCI)
	PA10 I/O (port)	A6 output (BSC)	RXD0 input (SCI)	—	—
	PA11 I/O (port)	A7 output (BSC)	TXD0 output (SCI)	$\overline{ADTR\overline{G}}$ input (A/D)	—
	PA12 I/O (port)	A8 output (BSC)	SCK0 I/O (SCI)	—	—
	PA13 I/O (port)	A9 output (BSC)	SCK1 I/O (SCI)	—	—
	PA14 I/O (port)	A10 output (BSC)	RXD1 input (SCI)	—	—
PA15 I/O (port)	CK output (CPG)	TXD1 output (SCI)	—	—	

Table 17.3 SH7146 Multiplexed Pins (Port B)

Port	Function 1 (Related Module)	Function 2 (Related Module)	Function 3 (Related Module)	Function 4 (Related Module)
B	PB2 I/O (port)	IRQ0 input (INTC)	$\overline{POE0}$ input (POE)	TIC5VS input (MTU2S)
	PB3 I/O (port)	IRQ1 input (INTC)	$\overline{POE1}$ input (POE)	TIC5V input (MTU2)
	PB4 I/O (port)	IRQ2 input (INTC)	$\overline{POE4}$ input (POE)	TIC5US input (MTU2S)
	PB5 I/O (port)	IRQ3 input (INTC)	$\overline{POE5}$ input (POE)	TIC5U input (MTU2)
	PB16 I/O (port)	$\overline{POE3}$ input (POE)	—	—
	PB17 I/O (port)	$\overline{POE7}$ input (POE)	—	—
	PB18 I/O (port)	$\overline{POE8}$ input (POE)	—	—

Table 17.4 SH7149 Multiplexed Pins (Port B)

Port	Function 1 (Related Module)	Function 2 (Related Module)	Function 3 (Related Module)	Function 4 (Related Module)	Function 5 (Related Module)
B	PB0 I/O (port)	BACK output (BSC)	TIC5WS input (MTU2S)	—	—
	PB1 I/O (port)	BREQ input (BSC)	TIC5W input (MTU2)	—	—
	PB2 I/O (port)	A16 output (BSC)	IRQ0 input (INTC)	$\overline{POE0}$ input (POE)	TIC5VS input (MTU2S)
	PB3 I/O (port)	A17 output (BSC)	IRQ1 input (INTC)	$\overline{POE1}$ input (POE)	TIC5V input (MTU2)
	PB4 I/O (port)	A18 output (BSC)	IRQ2 input (INTC)	$\overline{POE4}$ input (POE)	TIC5US input (MTU2S)
	PB5 I/O (port)	A19 output (BSC)	IRQ3 input (INTC)	$\overline{POE5}$ input (POE)	TIC5U input (MTU2)
	PB16 I/O (port)	$\overline{POE3}$ input (POE)	—	—	—
	PB17 I/O (port)	$\overline{POE7}$ input (POE)	—	—	—
	PB18 I/O (port)	$\overline{POE8}$ input (POE)	—	—	—

Table 17.5 SH7149 Multiplexed Pins (Port D)

Port	Function 1 (Related Module)	Function 2 (Related Module)	Function 3 (Related Module)	Function 4 (Related Module)
D	PD0 I/O (port)	D0 I/O (BSC)	RXD0 input (SCI)	—
	PD1 I/O (port)	D1 I/O (BSC)	TXD0 output (SCI)	—
	PD2 I/O (port)	D2 I/O (BSC)	SCK0 I/O (SCI)	—
	PD3 I/O (port)	D3 I/O (BSC)	RXD1 input (SCI)	—
	PD4 I/O (port)	D4 I/O (BSC)	IRQ0 input (INTC)	TXD1 output (SCI)
	PD5 I/O (port)	D5 I/O (BSC)	IRQ1 input (INTC)	SCK1 I/O (SCI)
	PD6 I/O (port)	D6 I/O (BSC)	IRQ2 input (INTC)	RXD2 input (SCI)
	PD7 I/O (port)	D7 I/O (BSC)	IRQ3 input (INTC)	TXD2 output (SCI)
	PD8 I/O (port)	D8 I/O (BSC)	SCK2 I/O (SCI)	AUDATA0 output (AUD)*
	PD9 I/O (port)	D9 I/O (BSC)	AUDATA1 output (AUD)*	—
	PD10 I/O (port)	D10 I/O (BSC)	AUDATA2 output (AUD)*	—
	PD11 I/O (port)	D11 I/O (BSC)	AUDATA3 output (AUD)*	—
	PD12 I/O (port)	D12 I/O (BSC)	—	—
	PD13 I/O (port)	D13 I/O (BSC)	—	—
	PD14 I/O (port)	D14 I/O (BSC)	AUDCK output (AUD)*	—
	PD15 I/O (port)	D15 I/O (BSC)	AUDSYNC output (AUD)*	—

Note: * Only in F-ZTAT version supporting full functions of E10A.

Table 17.6 SH7146 Multiplexed Pins (Port E)

Port	Function 1 (Related Module)	Function 2 (Related Module)	Function 3 (Related Module)	Function 4 (Related Module)
E	PE0 I/O (port)	TIOC0A I/O (MTU2)	—	—
	PE1 I/O (port)	TIOC0B I/O (MTU2)	RXD0 input (SCI)	—
	PE2 I/O (port)	TIOC0C I/O (MTU2)	TXD0 output (SCI)	—
	PE3 I/O (port)	TIOC0D I/O (MTU2)	SCK0 I/O (SCI)	—
	PE4 I/O (port)	TIOC1A I/O (MTU2)	RXD1 input (SCI)	—
	PE5 I/O (port)	TIOC1B I/O (MTU2)	TXD1 output (SCI)	—
	PE6 I/O (port)	TIOC2A I/O (MTU2)	SCK1 I/O (SCI)	—
	PE7 I/O (port)	TIOC2B I/O (MTU2)	—	—
	PE8 I/O (port)	TIOC3A I/O (MTU2)	—	—
	PE9 I/O (port)	TIOC3B I/O (MTU2)	—	—
	PE10 I/O (port)	TIOC3C I/O (MTU2)	—	—
	PE11 I/O (port)	TIOC3D I/O (MTU2)	—	—
	PE12 I/O (port)	TIOC4A I/O (MTU2)	—	—
	PE13 I/O (port)	TIOC4B I/O (MTU2)	\overline{MRES} input (INTC)	—
	PE14 I/O (port)	TIOC4C I/O (MTU2)	—	—
	PE15 I/O (port)	TIOC4D I/O (MTU2)	\overline{IRQOUT} output (INTC)	—
	PE16 I/O (port)	TIOC3BS I/O (MTU2S)	$\overline{ASEBRKAK}$ output (E10A)*	\overline{ASEBRK} input (E10A)*
	PE17 I/O (port)	TIOC3DS I/O (MTU2S)	TCK input (H-UDI)*	—
	PE18 I/O (port)	TIOC4AS I/O (MTU2S)	TDI input (H-UDI)*	—
	PE19 I/O (port)	TIOC4BS I/O (MTU2S)	TDO output (H-UDI)*	—
	PE20 I/O (port)	TIOC4CS I/O (MTU2S)	TMS input (H-UDI)*	—
	PE21 I/O (port)	TIOC4DS I/O (MTU2S)	\overline{TRST} input (H-UDI)*	—

Note: * F-ZTAT version only.

Table 17.7 SH7149 Multiplexed Pins (Port E)

Port	Function 1 (Related Module)	Function 2 (Related Module)	Function 3 (Related Module)	Function 4 (Related Module)	Function 5 (Related Module)
E	PE0 I/O (port)	TIOC0A I/O (MTU2)	—	—	—
	PE1 I/O (port)	TIOC0B I/O (MTU2)	RXD0 input (SCI)	—	—
	PE2 I/O (port)	TIOC0C I/O (MTU2)	TXD0 output (SCI)	—	—
	PE3 I/O (port)	TIOC0D I/O (MTU2)	SCK0 I/O (SCI)	—	—
	PE4 I/O (port)	A11 output (BSC)	TIOC1A I/O (MTU2)	RXD1 input (SCI)	—
	PE5 I/O (port)	A12 output (BSC)	TIOC1B I/O (MTU2)	TXD1 output (SCI)	—
	PE6 I/O (port)	A13 output (BSC)	TIOC2A I/O (MTU2)	SCK1 I/O (SCI)	—
	PE7 I/O (port)	A14 output (BSC)	TIOC2B I/O (MTU2)	—	—
	PE8 I/O (port)	A15 output (BSC)	TIOC3A I/O (MTU2)	—	—
	PE9 I/O (port)	TIOC3B I/O (MTU2)	—	—	—
	PE10 I/O (port)	$\overline{CS0}$ output (BSC)	TIOC3C I/O (MTU2)	—	—
	PE11 I/O (port)	TIOC3D I/O (MTU2)	—	—	—
	PE12 I/O (port)	TIOC4A I/O (MTU2)	—	—	—
	PE13 I/O (port)	TIOC4B I/O (MTU2)	\overline{MRES} input (INTC)	—	—
	PE14 I/O (port)	TIOC4C I/O (MTU2)	—	—	—
	PE15 I/O (port)	TIOC4D I/O (MTU2)	\overline{IRQOUT} output (INTC)	—	—
	PE16 I/O (port)	\overline{WAIT} input (BSC)	TIOC3BS I/O (MTU2S)	$\overline{ASEBRKAK}$ output (E10A)*	\overline{ASEBRK} input (E10A)*
	PE17 I/O (port)	$\overline{CS0}$ output (BSC)	TIOC3DS I/O (MTU2S)	TCK input (H-UDI)*	—
	PE18 I/O (port)	$\overline{CS1}$ output (BSC)	TIOC4AS I/O (MTU2S)	TDI input (H-UDI)*	—
	PE19 I/O (port)	\overline{RD} output (BSC)	TIOC4BS I/O (MTU2S)	TDO output (H-UDI)*	—
	PE20 I/O (port)	\overline{WRH} output (BSC)	TIOC4CS I/O (MTU2S)	TMS input (H-UDI)*	—
PE21 I/O (port)	\overline{WRL} output (BSC)	TIOC4DS I/O (MTU2S)	\overline{TRST} input (H-UDI)*	—	

Note: * F-ZTAT version only.

Table 17.8 Multiplexed Pins (Port F)

Port	Function 1 (Related Module)	Function 2 (Related Module)
F	PF0 input (port)	AN0 input (A/D)
	PF2 input (port)	AN2 input (A/D)
	PF4 input (port)	AN4 input (A/D)
	PF6 input (port)	AN6 input (A/D)
	PF8 input (port)	AN8 input (A/D)
	PF9 input (port)	AN9 input (A/D)
	PF10 input (port)	AN10 input (A/D)
	PF11 input (port)	AN11 input (A/D)
	PF12 input (port)	AN12 input (A/D)
	PF13 input (port)	AN13 input (A/D)
	PF14 input (port)	AN14 input (A/D)
	PF15 input (port)	AN15 input (A/D)

Note: During A/D conversion, the AN input function is enabled.

Table 17.9 SH7146 Pin Functions in Each Operating Mode

Pin No.	Pin Name	
	Single-Chip Mode (MCU Mode 3)	
	Initial Function	PFC Selected Function Possibilities
4, 19, 31, 48	Vcc	Vcc
6, 17, 33, 46	Vss	Vss
10, 50	Vcl	Vcl
72, 78	AVcc	AVcc
63, 75	AVss	AVss
60	PLLVss	PLLVss
55	EXTAL	EXTAL
54	XTAL	XTAL
59	MD1	MD1
58	FWE* ¹	FWE* ¹
52	$\overline{\text{RES}}$	$\overline{\text{RES}}$
53	WDTOVF	WDTOVF
57	NMI	NMI
56	$\overline{\text{ASEMD0}}^*1$	$\overline{\text{ASEMD0}}^*1$
47	PA0	PA0/POE0/RXD0
45	PA1	PA1/POE1/TXD0
44	PA2	PA2/IRQ0/POE2/SCK0
43	PA3	PA3/IRQ1/RXD1
42	PA4	PA4/IRQ2/TXD1
41	PA5	PA5/IRQ3/SCK1
40	PA6	PA6/UBCTRG/TCLKA/POE4
39	PA7	PA7/TCLKB/POE5/SCK2
38	PA8	PA8/TCLKC/POE6/RXD2
37	PA9	PA9/TCLKD/POE8/TXD2
36	PA10	PA10/RXD0
35	PA11	PA11/TXD0/ADTRG
34	PA12	PA12/SCK0
32	PA13	PA13/SCK1

Pin Name		
Single-Chip Mode (MCU Mode 3)		
Pin No.	Initial Function	PFC Selected Function Possibilities
30	PA14	PA14/RXD1
29	PA15	PA15/TXD1
62	PB2	PB2/IRQ0/ $\overline{POE0}$ /TIC5VS
61	PB3	PB3/IRQ1/ $\overline{POE1}$ /TIC5V
51	PB4	PB4/IRQ2/ $\overline{POE4}$ /TIC5US
49	PB5	PB5/IRQ3/ $\overline{POE5}$ /TIC5U
79	$\overline{POE3}$	PB16/ $\overline{POE3}$
80	$\overline{POE7}$	PB17/ $\overline{POE7}$
28	POE8	PB18/POE8
27	PE0	PE0/TIOC0A
26	PE1	PE1/TIOC0B/RXD0
25	PE2	PE2/TIOC0C/TXD0
24	PE3	PE3/TIOC0D/SCK0
23	PE4	PE4/TIOC1A/RXD1
22	PE5	PE5/TIOC1B/TXD1
21	PE6	PE6/TIOC2A/SCK1
20	PE7	PE7/TIOC2B
18	PE8	PE8/TIOC3A
15	PE9	PE9/TIOC3B
16	PE10	PE10/TIOC3C
14	PE11	PE11/TIOC3D
13	PE12	PE12/TIOC4A
12	PE13	PE13/TIOC4B/ \overline{MRES}
11	PE14	PE14/TIOC4C
9	PE15	PE15/TIOC4D/IRQOUT
8	PE16/ $\overline{ASEBRKAK}$ / \overline{ASEBRK}^{*2}	PE16/TIOC3BS
7	PE17/(TCK ^{*2})	PE17/TIOC3DS
5	PE18/(TDI ^{*2})	PE18/TIOC4AS
3	PE19/(TDO ^{*2})	PE19/TIOC4BS

Pin Name		
Single-Chip Mode (MCU Mode 3)		
Pin No.	Initial Function	PFC Selected Function Possibilities
2	PE20/(TMS* ²)	PE20/TIOC4CS
1	PE21/(TRST* ²)	PE21/TIOC4DS
77	PF0/AN0	PF0/AN0
76	PF2/AN2	PF2/AN2
74	PF4/AN4	PF4/AN4
73	PF6/AN6	PF6/AN6
71	PF8/AN8	PF8/AN8
70	PF9/AN9	PF9/AN9
69	PF10/AN10	PF10/AN10
68	PF11/AN11	PF11/AN11
67	PF12/AN12	PF12/AN12
66	PF13/AN13	PF13/AN13
65	PF14/AN14	PF14/AN14
64	PF15/AN15	PF15/AN15

Notes: 1. F-ZTAT version only.

2. F-ZTAT version only. Fixed to TMS, $\overline{\text{TRST}}$, TDI, TDO, TCK, and $\overline{\text{ASEBRKAK/ASEBRK}}$ when using the E10A (in ASEMD0 = low).

Table 17.10 SH7149 Pin Functions in Each Operating Mode (1)

Pin No.	Pin Name			
	On-Chip ROM Disabled (MCU Mode 0)		On-Chip ROM Disabled (MCU Mode 1)	
	Initial Function	PFC Selected Function Possibilities	Initial Function	PFC Selected Function Possibilities
5, 24, 39, 59, 73	Vcc	Vcc	Vcc	Vcc
7, 22, 41, 57	Vss	Vss	Vss	Vss
12, 61	Vcl	Vcl	Vcl	Vcl
90, 96	AVcc	AVcc	AVcc	AVcc
81, 93	AVss	AVss	AVss	AVss
75	PLLVss	PLLVss	PLLVss	PLLVss
67	EXTAL	EXTAL	EXTAL	EXTAL
66	XTAL	XTAL	XTAL	XTAL
72	MD0	MD0	MD0	MD0
71	MD1	MD1	MD1	MD1
70	FWE* ¹	FWE* ¹	FWE* ¹	FWE* ¹
64	$\overline{\text{RES}}$	$\overline{\text{RES}}$	$\overline{\text{RES}}$	$\overline{\text{RES}}$
65	WDTOVF	WDTOVF	WDTOVF	WDTOVF
69	NMI	NMI	NMI	NMI
68	$\overline{\text{ASEMD0}}^{*1}$	$\overline{\text{ASEMD0}}^{*1}$	$\overline{\text{ASEMD0}}^{*1}$	$\overline{\text{ASEMD0}}^{*1}$
63	A0	PA0/A0/POE0/RXD0	A0	PA0/A0/POE0/RXD0
62	A1	PA1/A1/POE1/TXD0	A1	PA1/A1/POE1/TXD0
60	A2	PA2/A2/IRQ0/POE2/SCK0	A2	PA2/A2/IRQ0/POE2/SCK0
58	A3	PA3/A3/IRQ1/RXD1	A3	PA3/A3/IRQ1/RXD1
56	A4	PA4/A4/IRQ2/TXD1	A4	PA4/A4/IRQ2/TXD1
55	A5	PA5/A5/IRQ3/SCK1	A5	PA5/A5/IRQ3/SCK1
54	$\overline{\text{RD}}$	PA6/ $\overline{\text{RD}}$ /UBCTR $\overline{\text{G}}$ /TCLKA /POE4	$\overline{\text{RD}}$	PA6/ $\overline{\text{RD}}$ /UBCTR $\overline{\text{G}}$ /TCLKA /POE4
53	PA7	PA7/ $\overline{\text{WRH}}$ /TCLKB/POE5/SCK2	$\overline{\text{WRH}}$	PA7/ $\overline{\text{WRH}}$ /TCLKB/POE5/SCK2
52	$\overline{\text{WRL}}$	PA8/ $\overline{\text{WRL}}$ /TCLKC/POE6/RXD2	$\overline{\text{WRL}}$	PA8/ $\overline{\text{WRL}}$ /TCLKC/POE6/RXD2
51	PA9	PA9/ $\overline{\text{WAIT}}$ /TCLKD/POE8/TXD2	PA9	PA9/ $\overline{\text{WAIT}}$ /TCLKD/POE8/TXD2
50	A6	PA10/A6/RXD0	A6	PA10/A6/RXD0

Pin No.	Pin Name			
	On-Chip ROM Disabled (MCU Mode 0)		On-Chip ROM Disabled (MCU Mode 1)	
	Initial Function	PFC Selected Function Possibilities	Initial Function	PFC Selected Function Possibilities
49	A7	PA11/A7/TXD0/ADTRG	A7	PA11/A7/TXD0/ADTRG
48	A8	PA12/A8/SCK0	A8	PA12/A8/SCK0
47	A9	PA13/A9/SCK1	A9	PA13/A9/SCK1
46	A10	PA14/A10/RXD1	A10	PA14/A10/RXD1
45	CK	PA15/CK/TXD1	CK	PA15/CK/TXD1
80	PB0	PB0/BACK/TIC5WS	PB0	PB0/BACK/TIC5WS
79	PB1	PB1/BREQ/TIC5W	PB1	PB1/BREQ/TIC5W
78	A16	PB2/A16/IRQ0/POE0/TIC5VS	A16	PB2/A16/IRQ0/POE0/TIC5VS
77	A17	PB3/A17/IRQ1/POE1/TIC5V	A17	PB3/A17/IRQ1/POE1/TIC5V
76	PB4	PB4/A18/IRQ2/POE4/TIC5US	PB4	PB4/A18/IRQ2/POE4/TIC5US
74	PB5	PB5/A19/IRQ3/POE5/TIC5U	PB5	PB5/A19/IRQ3/POE5/TIC5U
97	POE3	PB16/POE3	POE3	PB16/POE3
98	POE7	PB17/POE7	POE7	PB17/POE7
26	POE8	PB18/POE8	POE8	PB18/POE8
44	D0	PD0/D0/RXD0	D0	PD0/D0/RXD0
43	D1	PD1/D1/TXD0	D1	PD1/D1/TXD0
42	D2	PD2/D2/SCK0	D2	PD2/D2/SCK0
40	D3	PD3/D3/RXD1	D3	PD3/D3/RXD1
38	D4	PD4/D4/IRQ0/TXD1	D4	PD4/D4/IRQ0/TXD1
37	D5	PD5/D5/IRQ1/SCK1	D5	PD5/D5/IRQ1/SCK1
36	D6	PD6/D6/IRQ2/RXD2	D6	PD6/D6/IRQ2/RXD2
35	D7	PD7/D7/IRQ3/TXD2	D7	PD7/D7/IRQ3/TXD2
34	PD8/(AUDATA0 ^{*3})	PD8/D8/SCK2	D8/(AUDATA0 ^{*3})	PD8/D8/SCK2
33	PD9/(AUDATA1 ^{*3})	PD9/D9	D9/(AUDATA1 ^{*3})	PD9/D9
32	PD10 /(AUDATA2 ^{*3})	PD10/D10	D10/(AUDATA2 ^{*3})	PD10/D10
31	PD11 /(AUDATA3 ^{*3})	PD11/D11	D11/(AUDATA3 ^{*3})	PD11/D11
30	PD12	PD12/D12	D12	PD12/D12
29	PD13	PD13/D13	D13	PD13/D13

Pin No.	Pin Name			
	On-Chip ROM Disabled (MCU Mode 0)		On-Chip ROM Disabled (MCU Mode 1)	
	Initial Function	PFC Selected Function Possibilities	Initial Function	PFC Selected Function Possibilities
28	PD14/(AUDCK* ³)	PD14/D14	D14/(AUDCK* ³)	PD14/D14
27	PD15 /(AUDSYNC* ³)	PD15/D15	D15/(AUDSYNC* ³)	PD15/D15
25	PE0	PE0/TIOC0A	PE0	PE0/TIOC0A
23	PE1	PE1/TIOC0B/RXD0	PE1	PE1/TIOC0B/RXD0
21	PE2	PE2/TIOC0C/TXD0	PE2	PE2/TIOC0C/TXD0
20	PE3	PE3/TIOC0D/SCK0	PE3	PE3/TIOC0D/SCK0
19	A11	PE4/A11/TIOC1A/RXD1	A11	PE4/A11/TIOC1A/RXD1
18	A12	PE5/A12/TIOC1B/TXD1	A12	PE5/A12/TIOC1B/TXD1
17	A13	PE6/A13/TIOC2A/SCK1	A13	PE6/A13/TIOC2A/SCK1
16	A14	PE7/A14/TIOC2B	A14	PE7/A14/TIOC2B
15	A15	PE8/A15/TIOC3A	A15	PE8/A15/TIOC3A
13	PE9	PE9/TIOC3B	PE9	PE9/TIOC3B
14	$\overline{CS0}$	PE10/ $\overline{CS0}$ /TIOC3C	$\overline{CS0}$	PE10/ $\overline{CS0}$ /TIOC3C
11	PE11	PE11/TIOC3D	PE11	PE11/TIOC3D
10	PE12	PE12/TIOC4A	PE12	PE12/TIOC4A
9	PE13	PE13/TIOC4B/ \overline{MRES}	PE13	PE13/TIOC4B/ \overline{MRES}
8	PE14	PE14/TIOC4C	PE14	PE14/TIOC4C
6	PE15	PE15/TIOC4D/ \overline{IRQOUT}	PE15	PE15/TIOC4D/ \overline{IRQOUT}
4	PE16/(ASEBRKAK /ASEBRK* ²)	PE16/ \overline{WAIT} /TIOC3BS	PE16/(ASEBRKAK /ASEBRK* ²)	PE16/ \overline{WAIT} /TIOC3BS
3	PE17/(TCK* ²)	PE17/ $\overline{CS0}$ /TIOC3DS	PE17/(TCK* ²)	PE17/ $\overline{CS0}$ /TIOC3DS
2	PE18/(TDI* ²)	PE18/ $\overline{CS1}$ /TIOC4AS	PE18/(TDI* ²)	PE18/ $\overline{CS1}$ /TIOC4AS
1	PE19/(TDO* ²)	PE19/ \overline{RD} /TIOC4BS	PE19/(TDO* ²)	PE19/ \overline{RD} /TIOC4BS
100	PE20/(TMS* ²)	PE20/ \overline{WRH} /TIOC4CS	PE20/(TMS* ²)	PE20/ \overline{WRH} /TIOC4CS
99	PE21/(\overline{TRST} * ²)	PE21/WRL/TIOC4DS	PE21/(\overline{TRST} * ²)	PE21/WRL/TIOC4DS
95	PF0/AN0	PF0/AN0	PF0/AN0	PF0/AN0
94	PF2/AN2	PF2/AN2	PF2/AN2	PF2/AN2
92	PF4/AN4	PF4/AN4	PF4/AN4	PF4/AN4
91	PF6/AN6	PF6/AN6	PF6/AN6	PF6/AN6

Pin Name				
Pin No.	On-Chip ROM Disabled (MCU Mode 0)		On-Chip ROM Disabled (MCU Mode 1)	
	Initial Function	PFC Selected Function Possibilities	Initial Function	PFC Selected Function Possibilities
89	PF8/AN8	PF8/AN8	PF8/AN8	PF8/AN8
88	PF9/AN9	PF9/AN9	PF9/AN9	PF9/AN9
87	PF10/AN10	PF10/AN10	PF10/AN10	PF10/AN10
86	PF11/AN11	PF11/AN11	PF11/AN11	PF11/AN11
85	PF12/AN12	PF12/AN12	PF12/AN12	PF12/AN12
84	PF13/AN13	PF13/AN13	PF13/AN13	PF13/AN13
83	PF14/AN14	PF14/AN14	PF14/AN14	PF14/AN14
82	PF15/AN15	PF15/AN15	PF15/AN15	PF15/AN15

- Notes:
1. F-ZTAT version only.
 2. F-ZTAT version only. Fixed to TMS, $\overline{\text{TRST}}$, TDI, TDO, TCK, and $\overline{\text{ASEBRKAK}}/\overline{\text{ASEBRK}}$ when using the E10A (in $\overline{\text{ASEMD0}} = \text{low}$).
 3. Only in F-ZTAT version supporting full functions of E10A. Fixed as the AUD pins when using the AUD function of the E10A.

Table 17.11 SH7149 Pin Functions in Each Operating Mode (2)

Pin No.	Pin Name			
	On-Chip ROM Enabled (MCU Mode 2)		Single-Chip Mode (MCU Mode 3)	
	Initial Function	PFC Selected Function Possibilities	Initial Function	PFC Selected Function Possibilities
5, 24, 39, 59, 73	Vcc	Vcc	Vcc	Vcc
7, 22, 41, 57	Vss	Vss	Vss	Vss
12, 61	Vcl	Vcl	Vcl	Vcl
90, 96	AVcc	AVcc	AVcc	AVcc
81, 93	AVss	AVss	AVss	AVss
75	PLLVss	PLLVss	PLLVss	PLLVss
67	EXTAL	EXTAL	EXTAL	EXTAL
66	XTAL	XTAL	XTAL	XTAL
72	MD0	MD0	MD0	MD0
71	MD1	MD1	MD1	MD1
70	FWE* ¹	FWE* ¹	FWE* ¹	FWE* ¹
64	RES	RES	RES	RES
65	WDTOVF	WDTOVF	WDTOVF	WDTOVF
69	NMI	NMI	NMI	NMI
68	ASEMD0* ¹	ASEMD0* ¹	ASEMD0* ¹	ASEMD0* ¹
63	PA0	PA0/A0/POE0/RXD0	PA0	PA0/POE0/RXD0
62	PA1	PA1/A1/POE1/TXD0	PA1	PA1/POE1/TXD0
60	PA2	PA2/A2/IRQ0/POE2/SCK0	PA2	PA2/IRQ0/POE2/SCK0
58	PA3	PA3/A3/IRQ1/RXD1	PA3	PA3/IRQ1/RXD1
56	PA4	PA4/A4/IRQ2/TXD1	PA4	PA4/IRQ2/TXD1
55	PA5	PA5/A5/IRQ3/SCK1	PA5	PA5/IRQ3/SCK1
54	PA6	PA6/RD/UBCTRG/TCLKA /POE4	PA6	PA6/UBCTRG/TCLKA/POE4
53	PA7	PA7/WRH/TCLKB/POE5/SCK2	PA7	PA7/TCLKB/POE5/SCK2
52	PA8	PA8/WRL/TCLKC/POE6/RXD2	PA8	PA8/TCLKC/POE6/RXD2
51	PA9	PA9/WAIT/TCLKD/POE8/TXD2	PA9	PA9/TCLKD/POE8/TXD2
50	PA10	PA10/A6/RXD0	PA10	PA10/RXD0

Pin No.	Pin Name			
	On-Chip ROM Enabled (MCU Mode 2)		Single-Chip Mode (MCU Mode 3)	
	Initial Function	PFC Selected Function Possibilities	Initial Function	PFC Selected Function Possibilities
49	PA11	PA11/A7/TXD0/ADTRG	PA11	PA11/TXD0/ADTRG
48	PA12	PA12/A8/SCK0	PA12	PA12/SCK0
47	PA13	PA13/A9/SCK1	PA13	PA13/SCK1
46	PA14	PA14/A10/RXD1	PA14	PA14/RXD1
45	CK	PA15/CK/TXD1	PA15	PA15/TXD1
80	PB0	PB0/BACK/TIC5WS	PB0	PB0/TIC5WS
79	PB1	PB1/BREQ/TIC5W	PB1	PB1/TIC5W
78	PB2	PB2/A16/IRQ0/POE0/TIC5VS	PB2	PB2/IRQ0/POE0/TIC5VS
77	PB3	PB3/A17/IRQ1/POE1/TIC5V	PB3	PB3/IRQ1/POE1/TIC5V
76	PB4	PB4/A18/IRQ2/POE4/TIC5US	PB4	PB4/IRQ2/POE4/TIC5US
74	PB5	PB5/A19/IRQ3/POE5/TIC5U	PB5	PB5/IRQ3/POE5/TIC5U
97	POE3	PB16/POE3	POE3	PB16/POE3
98	POE7	PB17/POE7	POE7	PB17/POE7
26	POE8	PB18/POE8	POE8	PB18/POE8
44	PD0	PD0/D0/RXD0	PD0	PD0/RXD0
43	PD1	PD1/D1/TXD0	PD1	PD1/TXD0
42	PD2	PD2/D2/SCK0	PD2	PD2/SCK0
40	PD3	PD3/D3/RXD1	PD3	PD3/RXD1
38	PD4	PD4/D4/IRQ0/TXD1	PD4	PD4/IRQ0/TXD1
37	PD5	PD5/D5/IRQ1/SCK1	PD5	PD5/IRQ1/SCK1
36	PD6	PD6/D6/IRQ2/RXD2	PD6	PD6/IRQ2/RXD2
35	PD7	PD7/D7/IRQ3/TXD2	PD7	PD7/IRQ3/TXD2
34	PD8/(AUDATA0 ^{*3})	PD8/D8/SCK2	PD8/(AUDATA0 ^{*3})	PD8/SCK2
33	PD9/(AUDATA1 ^{*3})	PD9/D9	PD9/(AUDATA1 ^{*3})	PD9
32	PD10 /(AUDATA2 ^{*3})	PD10/D10	PD10 /(AUDATA2 ^{*3})	PD10
31	PD11 /(AUDATA3 ^{*3})	PD11/D11	PD11 /(AUDATA3 ^{*3})	PD11
30	PD12	PD12/D12	PD12	PD12
29	PD13	PD13/D13	PD13	PD13

Pin No.	Pin Name			
	On-Chip ROM Enabled (MCU Mode 2)		Single-Chip Mode (MCU Mode 3)	
	Initial Function	PFC Selected Function Possibilities	Initial Function	PFC Selected Function Possibilities
28	PD14/(AUDCK* ³)	PD14/D14	PD14/(AUDCK* ³)	PD14
27	PD15 /(AUDSYNC* ³)	PD15/D15	PD15 /(AUDSYNC* ³)	PD15
25	PE0	PE0/TIOC0A	PE0	PE0/TIOC0A
23	PE1	PE1/TIOC0B/RXD0	PE1	PE1/TIOC0B/RXD0
21	PE2	PE2/TIOC0C/TXD0	PE2	PE2/TIOC0C/TXD0
20	PE3	PE3/TIOC0D/SCK0	PE3	PE3/TIOC0D/SCK0
19	PE4	PE4/A11/TIOC1A/RXD1	PE4	PE4/TIOC1A/RXD1
18	PE5	PE5/A12/TIOC1B/TXD1	PE5	PE5/TIOC1B/TXD1
17	PE6	PE6/A13/TIOC2A/SCK1	PE6	PE6/TIOC2A/SCK1
16	PE7	PE7/A14/TIOC2B	PE7	PE7/TIOC2B
15	PE8	PE8/A15/TIOC3A	PE8	PE8/TIOC3A
13	PE9	PE9/TIOC3B	PE9	PE9/TIOC3B
14	PE10	PE10/ $\overline{CS0}$ /TIOC3C	PE10	PE10/TIOC3C
11	PE11	PE11/TIOC3D	PE11	PE11/TIOC3D
10	PE12	PE12/TIOC4A	PE12	PE12/TIOC4A
9	PE13	PE13/TIOC4B/MRES	PE13	PE13/TIOC4B/MRES
8	PE14	PE14/TIOC4C	PE14	PE14/TIOC4C
6	PE15	PE15/TIOC4D/ \overline{IRQOUT}	PE15	PE15/TIOC4D/ \overline{IRQOUT}
4	PE16/(ASEBRKAK /ASEBRK* ²)	PE16/ \overline{WAIT} /TIOC3BS	PE16/(ASEBRKAK /ASEBRK* ²)	PE16/TIOC3BS
3	PE17/(TCK* ²)	PE17/ $\overline{CS0}$ /TIOC3DS	PE17/(TCK* ²)	PE17/TIOC3DS
2	PE18/(TDI* ²)	PE18/ $\overline{CS1}$ /TIOC4AS	PE18/(TDI* ²)	PE18/TIOC4AS
1	PE19/(TDO* ²)	PE19/ \overline{RD} /TIOC4BS	PE19/(TDO* ²)	PE19/TIOC4BS
100	PE20/(TMS* ²)	PE20/ \overline{WRH} /TIOC4CS	PE20/(TMS* ²)	PE20/TIOC4CS
99	PE21/(TRST* ²)	PE21/WRL/TIOC4DS	PE21/(TRST* ²)	PE21/TIOC4DS
95	PF0/AN0	PF0/AN0	PF0/AN0	PF0/AN0
94	PF2/AN2	PF2/AN2	PF2/AN2	PF2/AN2
92	PF4/AN4	PF4/AN4	PF4/AN4	PF4/AN4
91	PF6/AN6	PF6/AN6	PF6/AN6	PF6/AN6

Pin Name				
Pin No.	On-Chip ROM Enabled (MCU Mode 2)		Single-Chip Mode (MCU Mode 3)	
	Initial Function	PFC Selected Function	Initial Function	PFC Selected Function
		Possibilities		Possibilities
89	PF8/AN8	PF8/AN8	PF8/AN8	PF8/AN8
88	PF9/AN9	PF9/AN9	PF9/AN9	PF9/AN9
87	PF10/AN10	PF10/AN10	PF10/AN10	PF10/AN10
86	PF11/AN11	PF11/AN11	PF11/AN11	PF11/AN11
85	PF12/AN12	PF12/AN12	PF12/AN12	PF12/AN12
84	PF13/AN13	PF13/AN13	PF13/AN13	PF13/AN13
83	PF14/AN14	PF14/AN14	PF14/AN14	PF14/AN14
82	PF15/AN15	PF15/AN15	PF15/AN15	PF15/AN15

- Notes:
1. F-ZTAT version only.
 2. F-ZTAT version only. Fixed to TMS, $\overline{\text{TRST}}$, TDI, TDO, TCK, and $\overline{\text{ASEBRKAK}}/\overline{\text{ASEBRK}}$ when using the E10A (in $\overline{\text{ASEMD0}} = \text{low}$).
 3. Only in F-ZTAT version supporting full functions of E10A. Fixed as the AUD pins when using the AUD function of the E10A.

17.1 Register Descriptions

The PFC has the following registers. For details on register addresses and register states in each processing state, refer to section 23, List of Registers.

Table 17.12 Register Configuration

Register Name	Abbreviation	R/W	Initial Value	Address	Access Size
Port A I/O register L	PAIORL	R/W	H'0000	H'FFFFD106	8, 16
Port A control register L4	PACRL4	R/W	H'0000*	H'FFFFD110	8, 16, 32
Port A control register L3	PACRL3	R/W	H'0000*	H'FFFFD112	8, 16
Port A control register L2	PACRL2	R/W	H'0000*	H'FFFFD114	8, 16, 32
Port A control register L1	PACRL1	R/W	H'0000*	H'FFFFD116	8, 16
Port B I/O register H	PBIORH	R/W	H'0000	H'FFFFD184	8, 16, 32
Port B I/O register L	PBIORL	R/W	H'0000	H'FFFFD186	8, 16
Port B control register H1	PBCRH1	R/W	H'0111	H'FFFFD18E	8, 16
Port B control register L2	PBCRL2	R/W	H'0000	H'FFFFD194	8, 16, 32
Port B control register L1	PBCRL1	R/W	H'0000*	H'FFFFD196	8, 16
Port D I/O register L	PDIORL	R/W	H'0000	H'FFFFD286	8, 16
Port D control register L4	PDCRL4	R/W	H'0000*	H'FFFFD290	8, 16, 32
Port D control register L3	PDCRL3	R/W	H'0000*	H'FFFFD292	8, 16
Port D control register L2	PDCRL2	R/W	H'0000*	H'FFFFD294	8, 16, 32
Port D control register L1	PDCRL1	R/W	H'0000*	H'FFFFD296	8, 16
Port E I/O register H	PEIORH	R/W	H'0000	H'FFFFD304	8, 16, 32
Port E I/O register L	PEIORL	R/W	H'0000	H'FFFFD306	8, 16
Port E control register H2	PECRH2	R/W	H'0000	H'FFFFD30C	8, 16, 32
Port E control register H1	PECRH1	R/W	H'0000	H'FFFFD30E	8, 16
Port E control register L4	PECRL4	R/W	H'0000	H'FFFFD310	8, 16, 32
Port E control register L3	PECRL3	R/W	H'0000*	H'FFFFD312	8, 16
Port E control register L2	PECRL2	R/W	H'0000*	H'FFFFD314	8, 16, 32
Port E control register L1	PECRL1	R/W	H'0000	H'FFFFD316	8, 16
IRQOUT function control register	IFCR	R/W	H'0000	H'FFFFD322	8, 16

Note: * For SH7149, the initial value differs in the on-chip ROM enabled/disabled external-extension mode. For details, refer to register descriptions in this section.

17.1.1 Port A I/O Register L (PAIORL)

PAIORL is a 16-bit readable/writable register that is used to set the pins on port A as inputs or outputs. Bits PA15IOR to PA0IOR correspond to pins PA15 to PA0 (names of multiplexed pins are here given as port names and pin numbers alone). PAIORL is enabled when the port A pins are functioning as general-purpose inputs/outputs (PA15 to PA0). In other states, PAIORL is disabled.

A given pin on port A will be an output pin if the corresponding bit in PAIORL is set to 1, and an input pin if the bit is cleared to 0.

The initial value of PAIORL is H'0000.

Bit:	15	14	13	12	11	10	9	8	7	6	5	4	3	2	1	0
	PA15 IOR	PA14 IOR	PA13 IOR	PA12 IOR	PA11 IOR	PA10 IOR	PA9 IOR	PA8 IOR	PA7 IOR	PA6 IOR	PA5 IOR	PA4 IOR	PA3 IOR	PA2 IOR	PA1 IOR	PA0 IOR
Initial value:	0	0	0	0	0	0	0	0	0	0	0	0	0	0	0	0
R/W:	R/W	R/W	R/W	R/W	R/W	R/W	R/W	R/W	R/W	R/W	R/W	R/W	R/W	R/W	R/W	R/W

17.1.2 Port A Control Registers L1 to L4 (PACRL1 to PACRL4)

PACRL1 to PACRL4 are 16-bit readable/writable registers that are used to select the functions of the multiplexed pins on port A.

SH7146:

- Port A Control Register L4 (PACRL4)

Bit:	15	14	13	12	11	10	9	8	7	6	5	4	3	2	1	0
	-	PA15 MD2	PA15 MD1	PA15 MD0	-	PA14 MD2	PA14 MD1	PA14 MD0	-	PA13 MD2	PA13 MD1	PA13 MD0	-	PA12 MD2	PA12 MD1	PA12 MD0
Initial value:	0	0	0	0	0	0	0	0	0	0	0	0	0	0	0	0
R/W:	R	R/W	R/W	R/W	R	R/W	R/W	R/W	R	R/W	R/W	R/W	R	R/W	R/W	R/W

Bit	Bit Name	Initial Value	R/W	Description
15	—	0	R	Reserved This bit is always read as 0. The write value should always be 0.
14	PA15MD2	0	R/W	PA15 Mode
13	PA15MD1	0	R/W	Select the function of the PA15/TXD1 pin.
12	PA15MD0	0	R/W	000: PA15 I/O (port) 110: TXD1 output (SCI) Other than above: Setting prohibited

Bit	Bit Name	Initial Value	R/W	Description
11	—	0	R	Reserved This bit is always read as 0. The write value should always be 0.
10	PA14MD2	0	R/W	PA14 Mode
9	PA14MD1	0	R/W	Select the function of the PA14/RXD1 pin.
8	PA14MD0	0	R/W	000: PA14 I/O (port) 110: RXD1 input (SCI) Other than above: Setting prohibited
7	—	0	R	Reserved This bit is always read as 0. The write value should always be 0.
6	PA13MD2	0	R/W	PA13 Mode
5	PA13MD1	0	R/W	Select the function of the PA13/SCK1 pin.
4	PA13MD0	0	R/W	000: PA13 I/O (port) 110: SCK1 I/O (SCI) Other than above: Setting prohibited
3	—	0	R	Reserved This bit is always read as 0. The write value should always be 0.
2	PA12MD2	0	R/W	PA12 Mode
1	PA12MD1	0	R/W	Select the function of the PA12/SCK0 pin.
0	PA12MD0	0	R/W	000: PA12 I/O (port) 110: SCK0 I/O (SCI) Other than above: Setting prohibited

- Port A Control Register L3 (PACRL3)

Bit:	15	14	13	12	11	10	9	8	7	6	5	4	3	2	1	0
	-	PA11 MD2	PA11 MD1	PA11 MD0	-	PA10 MD2	PA10 MD1	PA10 MD0	-	PA9 MD2	PA9 MD1	PA9 MD0	-	PA8 MD2	PA8 MD1	PA8 MD0
Initial value:	0	0	0	0	0	0	0	0	0	0	0	0	0	0	0	0
R/W:	R	R/W	R/W	R/W	R	R/W	R/W	R/W	R	R/W	R/W	R/W	R	R/W	R/W	R/W

Bit	Bit Name	Initial Value	R/W	Description
15	—	0	R	Reserved This bit is always read as 0. The write value should always be 0.
14	PA11MD2	0	R/W	PA11 Mode
13	PA11MD1	0	R/W	Select the function of the PA11/TXD0/ $\overline{\text{ADTRG}}$ pin.
12	PA11MD0	0	R/W	000: PA11 I/O (port) 010: $\overline{\text{ADTRG}}$ input (A/D) 110: TXD0 output (SCI) Other than above: Setting prohibited
11	—	0	R	Reserved This bit is always read as 0. The write value should always be 0.
10	PA10MD2	0	R/W	PA10 Mode
9	PA10MD1	0	R/W	Select the function of the PA10/RXD0 pin.
8	PA10MD0	0	R/W	000: PA10 I/O (port) 110: RXD0 input (SCI) Other than above: Setting prohibited
7	—	0	R	Reserved This bit is always read as 0. The write value should always be 0.
6	PA9MD2	0	R/W	PA9 Mode
5	PA9MD1	0	R/W	Select the function of the PA9/TCLKD/TXD2 pin.
4	PA9MD0	0	R/W	000: PA9 I/O (port) 001: TCLKD input (MTU2) 110: TXD2 output (SCI) 111: POE8 input (POE) Other than above: Setting prohibited

Bit	Bit Name	Initial Value	R/W	Description
3	—	0	R	Reserved This bit is always read as 0. The write value should always be 0.
2	PA8MD2	0	R/W	PA8 Mode
1	PA8MD1	0	R/W	Select the function of the PA8/TCLKC/ $\overline{\text{POE6}}$ /RXD2 pin.
0	PA8MD0	0	R/W	000: PA8 I/O (port) 001: TCLKC input (MTU2) 110: RXD2 input (SCI) 111: $\overline{\text{POE6}}$ input (POE) Other than above: Setting prohibited

- Port A Control Register L2 (PACRL2)

Bit:	15	14	13	12	11	10	9	8	7	6	5	4	3	2	1	0
	-	PA7 MD2	PA7 MD1	PA7 MD0	-	PA6 MD2	PA6 MD1	PA6 MD0	-	PA5 MD2	PA5 MD1	PA5 MD0	-	PA4 MD2	PA4 MD1	PA4 MD0
Initial value:	0	0	0	0	0	0	0	0	0	0	0	0	0	0	0	0
R/W:	R	R/W	R/W	R/W	R	R/W	R/W	R/W	R	R/W	R/W	R/W	R	R/W	R/W	R/W

Bit	Bit Name	Initial Value	R/W	Description
15	—	0	R	Reserved This bit is always read as 0. The write value should always be 0.
14	PA7MD2	0	R/W	PA7 Mode
13	PA7MD1	0	R/W	Select the function of the PA7/TCLKB/ $\overline{\text{POE5}}$ /SCK2 pin.
12	PA7MD0	0	R/W	000: PA7 I/O (port) 001: TCLKB input (MTU2) 110: SCK2 I/O (SCI) 111: $\overline{\text{POE5}}$ input (POE) Other than above: Setting prohibited
11	—	0	R	Reserved This bit is always read as 0. The write value should always be 0.

Bit	Bit Name	Initial Value	R/W	Description
10	PA6MD2	0	R/W	PA6 Mode
9	PA6MD1	0	R/W	Select the function of the PA6/UBCTRG/TCLKA/POE4 pin.
8	PA6MD0	0	R/W	000: PA6 I/O (port) 001: TCLKA input (MTU2) 101: UBCTRG output (UBC) 111: POE4 input (POE) Other than above: Setting prohibited
7	—	0	R	Reserved This bit is always read as 0. The write value should always be 0.
6	PA5MD2	0	R/W	PA5 Mode
5	PA5MD1	0	R/W	Select the function of the PA5/IRQ3/SCK1 pin.
4	PA5MD0	0	R/W	000: PA5 I/O (port) 001: SCK1 I/O (SCI) 111: IRQ3 input (INTC) Other than above: Setting prohibited
3	—	0	R	Reserved This bit is always read as 0. The write value should always be 0.
2	PA4MD2	0	R/W	PA4 Mode
1	PA4MD1	0	R/W	Select the function of the PA4/IRQ2/TXD1 pin.
0	PA4MD0	0	R/W	000: PA4 I/O (port) 001: TXD1 output (SCI) 111: IRQ2 input (INTC) Other than above: Setting prohibited

- Port A Control Register L1 (PACRL1)

Bit:	15	14	13	12	11	10	9	8	7	6	5	4	3	2	1	0
	-	PA3 MD2	PA3 MD1	PA3 MD0	-	PA2 MD2	PA2 MD1	PA2 MD0	-	PA1 MD2	PA1 MD1	PA1 MD0	-	PA0 MD2	PA0 MD1	PA0 MD0
Initial value:	0	0	0	0	0	0	0	0	0	0	0	0	0	0	0	0
R/W:	R	R/W	R/W	R/W	R	R/W	R/W	R/W	R	R/W	R/W	R/W	R	R/W	R/W	R/W

Bit	Bit Name	Initial Value	R/W	Description
15	—	0	R	Reserved This bit is always read as 0. The write value should always be 0.
14	PA3MD2	0	R/W	PA3 Mode
13	PA3MD1	0	R/W	Select the function of the PA3/IRQ1/RXD1 pin.
12	PA3MD0	0	R/W	000: PA3 I/O (port) 001: RXD1 input (SCI) 111: IRQ1 input (INTC) Other than above: Setting prohibited
11	—	0	R	Reserved This bit is always read as 0. The write value should always be 0.
10	PA2MD2	0	R/W	PA2 Mode
9	PA2MD1	0	R/W	Select the function of the PA2/IRQ0/ $\overline{\text{POE2}}$ /SCK0 pin.
8	PA2MD0	0	R/W	000: PA2 I/O (port) 001: SCK0 I/O (SCI) 011: IRQ0 input (INTC) 111: $\overline{\text{POE2}}$ input (POE) Other than above: Setting prohibited
7	—	0	R	Reserved This bit is always read as 0. The write value should always be 0.
6	PA1MD2	0	R/W	PA1 Mode
5	PA1MD1	0	R/W	Select the function of the PA1/ $\overline{\text{POE1}}$ /TXD0 pin.
4	PA1MD0	0	R/W	000: PA1 I/O (port) 001: TXD0 output (SCI) 111: $\overline{\text{POE1}}$ input (POE) Other than above: Setting prohibited

Bit	Bit Name	Initial Value	R/W	Description
3	—	0	R	Reserved This bit is always read as 0. The write value should always be 0.
2	PA0MD2	0	R/W	PA0 Mode
1	PA0MD1	0	R/W	Select the function of the PA0/ $\overline{\text{POE0}}$ /RXD0 pin.
0	PA0MD0	0	R/W	000: PA0 I/O (port) 001: RXD0 input (SCI) 111: $\overline{\text{POE0}}$ input (POE) Other than above: Setting prohibited

SH7149:

• Port A Control Register L4 (PACRL4)

Bit:	15	14	13	12	11	10	9	8	7	6	5	4	3	2	1	0
	-	PA15 MD2	PA15 MD1	PA15 MD0	-	PA14 MD2	PA14 MD1	PA14 MD0	-	PA13 MD2	PA13 MD1	PA13 MD0	-	PA12 MD2	PA12 MD1	PA12 MD0
Initial value:	0	0	0	0* ¹	0	0* ²	0	0	0	0* ²	0	0	0	0* ²	0	0
R/W:	R	R/W	R/W	R/W	R	R/W	R/W	R/W	R	R/W	R/W	R/W	R	R/W	R/W	R/W

- Notes: 1. The initial value is 1 in the on-chip ROM enabled/disabled external-extension mode.
2. The initial value is 1 in the on-chip ROM disabled external-extension mode.

Bit	Bit Name	Initial Value	R/W	Description
15	—	0	R	Reserved This bit is always read as 0. The write value should always be 0.
14	PA15MD2	0	R/W	PA15 Mode
13	PA15MD1	0	R/W	Select the function of the PA15/CK/TXD1 pin.
12	PA15MD0	0* ¹	R/W	000: PA15 I/O (port) 001: CK output (CPG)* ³ 110: TXD1 output (SCI) Other than above: Setting prohibited
11	—	0	R	Reserved This bit is always read as 0. The write value should always be 0.

Bit	Bit Name	Initial Value	R/W	Description
10	PA14MD2	0* ²	R/W	PA14 Mode
9	PA14MD1	0	R/W	Select the function of the PA14/A10/RXD1 pin.
8	PA14MD0	0	R/W	000: PA14 I/O (port) 100: A10 output (BSC)* ³ 110: RXD1 input (SCI) Other than above: Setting prohibited
7	—	0	R	Reserved This bit is always read as 0. The write value should always be 0.
6	PA13MD2	0* ²	R/W	PA13 Mode
5	PA13MD1	0	R/W	Select the function of the PA13/A9/SCK1 pin.
4	PA13MD0	0	R/W	000: PA13 I/O (port) 100: A9 output (BSC)* ³ 110: SCK1 I/O (SCI) Other than above: Setting prohibited
3	—	0	R	Reserved This bit is always read as 0. The write value should always be 0.
2	PA12MD2	0* ²	R/W	PA12 Mode
1	PA12MD1	0	R/W	Select the function of the PA12/A8/SCK0 pin.
0	PA12MD0	0	R/W	000: PA12 I/O (port) 100: A8 output (BSC)* ³ 110: SCK0 I/O (SCI) Other than above: Setting prohibited

- Notes:
1. The initial value is 1 in the on-chip ROM enabled/disabled external-extension mode.
 2. The initial value is 1 in the on-chip ROM disabled external-extension mode.
 3. This function is enabled only in the on-chip ROM enabled/disabled external-extension mode. Do not set 1 in single-chip mode.

- Port A Control Register L3 (PACRL3)

Bit:	15	14	13	12	11	10	9	8	7	6	5	4	3	2	1	0
	-	PA11 MD2	PA11 MD1	PA11 MD0	-	PA10 MD2	PA10 MD1	PA10 MD0	-	PA9 MD2	PA9 MD1	PA9 MD0	-	PA8 MD2	PA8 MD1	PA8 MD0
Initial value:	0	0*	0	0	0	0*	0	0	0	0	0	0	0	0*	0	0
R/W:	R	R/W	R/W	R/W	R	R/W	R/W	R/W	R	R/W	R/W	R/W	R	R/W	R/W	R/W

Note: * The initial value is 1 in the on-chip ROM disabled external-extension mode.

Bit	Bit Name	Initial Value	R/W	Description
15	—	0	R	Reserved This bit is always read as 0. The write value should always be 0.
14	PA11MD2	0* ¹	R/W	PA11 Mode
13	PA11MD1	0	R/W	Select the function of the PA11/A7/TXD0/ $\overline{\text{ADTRG}}$ pin.
12	PA11MD0	0	R/W	000: PA11 I/O (port) 010: $\overline{\text{ADTRG}}$ input (A/D) 100: A7 output (BSC)* ² 110: TXD0 output (SCI) Other than above: Setting prohibited
11	—	0	R	Reserved This bit is always read as 0. The write value should always be 0.
10	PA10MD2	0* ¹	R/W	PA10 Mode
9	PA10MD1	0	R/W	Select the function of the PA10/A6/RXD0 pin.
8	PA10MD0	0	R/W	000: PA10 I/O (port) 100: A6 output (BSC)* ² 110: RXD0 input (SCI) Other than above: Setting prohibited
7	—	0	R	Reserved This bit is always read as 0. The write value should always be 0.

Bit	Bit Name	Initial Value	R/W	Description
6	PA9MD2	0	R/W	PA9 Mode
5	PA9MD1	0	R/W	Select the function of the PA9/ $\overline{\text{WAIT}}$ /TCLKD/TXD2 pin.
4	PA9MD0	0	R/W	000: PA9 I/O (port) 001: TCLKD input (MTU2) 100: $\overline{\text{WAIT}}$ input (BSC)* ² 110: TXD2 output (SCI) 111: $\overline{\text{POE8}}$ input (POE) Other than above: Setting prohibited
3	—	0	R	Reserved This bit is always read as 0. The write value should always be 0.
2	PA8MD2	0* ¹	R/W	PA8 Mode
1	PA8MD1	0	R/W	Select the function of the
0	PA8MD0	0	R/W	PA8/ $\overline{\text{WRL}}$ /TCLKC/ $\overline{\text{POE6}}$ /RXD2 pin. 000: PA8 I/O (port) 001: TCLKC input (MTU2) 100: $\overline{\text{WRL}}$ output (BSC)* ² 110: RXD2 input (SCI) 111: $\overline{\text{POE6}}$ input (POE) Other than above: Setting prohibited

- Notes: 1. The initial value is 1 in the on-chip ROM disabled external-extension mode.
2. This function is enabled only in the on-chip ROM enabled/disabled external-extension mode. Do not set 1 in single-chip mode.

- Port A Control Register L2 (PACRL2)

Bit:	15	14	13	12	11	10	9	8	7	6	5	4	3	2	1	0
	-	PA7 MD2	PA7 MD1	PA7 MD0	-	PA6 MD2	PA6 MD1	PA6 MD0	-	PA5 MD2	PA5 MD1	PA5 MD0	-	PA4 MD2	PA4 MD1	PA4 MD0
Initial value:	0	0* ¹	0	0	0	0	0* ²	0* ²	0	0* ²	0	0	0	0* ²	0	0
R/W:	R	R/W	R/W	R/W	R	R/W	R/W	R/W	R	R/W	R/W	R/W	R	R/W	R/W	R/W

- Notes: 1. The initial value is 1 in the on-chip ROM disabled 16-bit external-extension mode.
 2. The initial value is 1 in the on-chip ROM disabled external-extension mode.

Bit	Bit Name	Initial Value	R/W	Description
15	—	0	R	Reserved This bit is always read as 0. The write value should always be 0.
14	PA7MD2	0* ¹	R/W	PA7 Mode
13	PA7MD1	0	R/W	Select the function of the PA7/ $\overline{\text{WRH}}$ /TCLKB/ $\overline{\text{POE5}}$ /SCK2 pin.
12	PA7MD0	0	R/W	000: PA7 I/O (port) 001: TCLKB input (MTU2) 100: $\overline{\text{WRH}}$ output (BSC)* ³ 110: SCK2 I/O (SCI) 111: $\overline{\text{POE5}}$ input (POE) Other than above: Setting prohibited
11	—	0	R	Reserved This bit is always read as 0. The write value should always be 0.
10	PA6MD2	0	R/W	PA6 Mode
9	PA6MD1	0* ²	R/W	Select the function of the PA6/RD/ $\overline{\text{UBCTR}}\overline{\text{G}}$ /TCLKA/ $\overline{\text{POE4}}$ pin.
8	PA6MD0	0* ²	R/W	000: PA6 I/O (port) 001: TCLKA input (MTU2) 011: $\overline{\text{RD}}$ output (BSC)* ³ 101: $\overline{\text{UBCTR}}\overline{\text{G}}$ output (UBC) 111: $\overline{\text{POE4}}$ input (POE) Other than above: Setting prohibited

Bit	Bit Name	Initial Value	R/W	Description
7	—	0	R	Reserved This bit is always read as 0. The write value should always be 0.
6	PA5MD2	0* ²	R/W	PA5 Mode
5	PA5MD1	0	R/W	Select the function of the PA5/A5/IRQ3/SCK1 pin.
4	PA5MD0	0	R/W	000: PA5 I/O (port) 001: SCK1 I/O (SCI) 100: A5 output (BSC)* ³ 111: IRQ3 input (INTC) Other than above: Setting prohibited
3	—	0	R	Reserved This bit is always read as 0. The write value should always be 0.
2	PA4MD2	0* ²	R/W	PA4 Mode
1	PA4MD1	0	R/W	Select the function of the PA4/A4/IRQ2/TXD1 pin.
0	PA4MD0	0	R/W	000: PA4 I/O (port) 001: TXD1 output (SCI) 100: A4 output (BSC)* ³ 111: IRQ2 input (INTC) Other than above: Setting prohibited

- Notes: 1. The initial value is 1 in the on-chip ROM disabled 16-bit external-extension mode.
 2. The initial value is 1 in the on-chip ROM disabled external-extension mode.
 3. This function is enabled only in the on-chip ROM enabled/disabled external-extension mode. Do not set 1 in single-chip mode.

- Port A Control Register L1 (PACRL1)

Bit:	15	14	13	12	11	10	9	8	7	6	5	4	3	2	1	0
	-	PA3 MD2	PA3 MD1	PA3 MD0	-	PA2 MD2	PA2 MD1	PA2 MD0	-	PA1 MD2	PA1 MD1	PA1 MD0	-	PA0 MD2	PA0 MD1	PA0 MD0
Initial value:	0	0*	0	0	0	0*	0	0	0	0*	0	0	0	0*	0	0
R/W:	R	R/W	R/W	R/W	R	R/W	R/W	R/W	R	R/W	R/W	R/W	R	R/W	R/W	R/W

Note: * The initial value is 1 in the on-chip ROM disabled external-extension mode.

Bit	Bit Name	Initial Value	R/W	Description
15	—	0	R	Reserved This bit is always read as 0. The write value should always be 0.
14	PA3MD2	0* ¹	R/W	PA3 Mode
13	PA3MD1	0	R/W	Select the function of the PA3/A3/IRQ1/RXD1 pin.
12	PA3MD0	0	R/W	000: PA3 I/O (port) 001: RXD1 input (SCI) 100: A3 output (BSC)* ² 111: IRQ1 input (INTC) Other than above: Setting prohibited
11	—	0	R	Reserved This bit is always read as 0. The write value should always be 0.
10	PA2MD2	0* ¹	R/W	PA2 Mode
9	PA2MD1	0	R/W	Select the function of the PA2/A2/IRQ0/ $\overline{\text{POE2}}$ /SCK0 pin.
8	PA2MD0	0	R/W	000: PA2 I/O (port) 001: SCK0 I/O (SCI) 011: IRQ0 input (INTC) 100: A2 output (BSC)* ² 111: $\overline{\text{POE2}}$ input (POE) Other than above: Setting prohibited
7	—	0	R	Reserved This bit is always read as 0. The write value should always be 0.

Bit	Bit Name	Initial Value	R/W	Description
6	PA1MD2	0* ¹	R/W	PA1 Mode
5	PA1MD1	0	R/W	Select the function of the PA1/A1/ $\overline{\text{POE1}}$ /TXD0 pin.
4	PA1MD0	0	R/W	000: PA1 I/O (port) 001: TXD0 output (SCI) 100: A1 output (BSC)* ² 111: $\overline{\text{POE1}}$ input (POE) Other than above: Setting prohibited
3	—	0	R	Reserved This bit is always read as 0. The write value should always be 0.
2	PA0MD2	0* ¹	R/W	PA0 Mode
1	PA0MD1	0	R/W	Select the function of the PA0/A0/ $\overline{\text{POE0}}$ /RXD0 pin.
0	PA0MD0	0	R/W	000: PA0 I/O (port) 001: RXD0 input (SCI) 100: A0 output (BSC)* ² 111: $\overline{\text{POE0}}$ input (POE) Other than above: Setting prohibited

Notes: 1. The initial value is 1 in the on-chip ROM disabled external-extension mode.

2. This function is enabled only in the on-chip ROM enabled/disabled external-extension mode. Do not set 1 in single-chip mode.

17.1.3 Port B I/O Register L, H (PBIORL, PBIORH)

PBIORL and PBIORH are 16-bit readable/writable registers that are used to set the pins on port B as inputs or outputs. Bits PB18IOR to PB16IOR and PB5IOR to PB0IOR correspond to pins PB18 to PB16 and PB5 to PB0, respectively (names of multiplexed pins are here given as port names and pin numbers alone). PBIORL is enabled when the port B pins are functioning as general-purpose inputs/outputs (PB5 to PB0). In other states, PBIORL is disabled. PBIORH is enabled when the port B pins are functioning as general-purpose inputs/outputs (PB18 to PB16). In other states, PBIORH is disabled.

A given pin on port B will be an output pin if the corresponding bit in PBIORH or PBIORL is set to 1, and an input pin if the bit is cleared to 0.

However, bits 1 and 0 of PBIORL are disabled in SH7146.

Bits 15 to 6 of PBIORL and bits 15 to 3 of PBIORH are reserved. These bits are always read as 0. The write value should always be 0.

The initial value of PBIORL and PBIORH are H'0000, respectively.

- Port B I/O Register H (PBIORH)

Bit:	15	14	13	12	11	10	9	8	7	6	5	4	3	2	1	0
	-	-	-	-	-	-	-	-	-	-	-	-	-	PB18 IOR	PB17 IOR	PB16 IOR
Initial value:	0	0	0	0	0	0	0	0	0	0	0	0	0	0	0	0
R/W:	R	R	R	R	R	R	R	R	R	R	R	R	R	R/W	R/W	R/W

- Port B I/O Register L (PBIORL)

Bit:	15	14	13	12	11	10	9	8	7	6	5	4	3	2	1	0
	-	-	-	-	-	-	-	-	-	-	PB5 IOR	PB4 IOR	PB3 IOR	PB2 IOR	PB1 IOR	PB0 IOR
Initial value:	0	0	0	0	0	0	0	0	0	0	0	0	0	0	0	0
R/W:	R	R	R	R	R	R	R	R	R	R	R/W	R/W	R/W	R/W	R/W	R/W

17.1.4 Port B Control Registers L1, L2, H1 (PBCRL1, PBCRL2, PBCRH1)

PBCRL1, PBCRL2, and PBCRH1 are 16-bit readable/writable registers that are used to select the function of the multiplexed pins on port B.

SH7146:

- Port B Control Register H1 (PBCRH1)

Bit:	15	14	13	12	11	10	9	8	7	6	5	4	3	2	1	0
	-	-	-	-	-	-	-	PB18 MD	-	-	-	PB17 MD	-	-	-	PB16 MD
Initial value:	0	0	0	0	0	0	0	1	0	0	0	1	0	0	0	1
R/W:	R	R	R	R	R	R	R	R/W*	R	R	R	R/W*	R	R	R	R/W*

Note: * After a power-on reset, write can be performed only once.
Rewrite must be performed when the POE function is selected as the initial value.

Bit	Bit Name	Initial Value	R/W	Description
15 to 9	—	All 0	R	Reserved These bits are always read as 0. The write value should always be 0.
8	PB18MD	1	R/W*	PB18 Mode Select the function of the PB18/ $\overline{\text{POE}}8$ pin. 0: PB18 I/O (port) 1: $\overline{\text{POE}}8$ input (POE)
7 to 5	—	All 0	R	Reserved These bits are always read as 0. The write value should always be 0.
4	PB17MD	1	R/W*	PB17 Mode Select the function of the PB17/ $\overline{\text{POE}}7$ pin. 0: PB17 I/O (port) 1: $\overline{\text{POE}}7$ input (POE)
3 to 1	—	All 0	R	Reserved These bits are always read as 0. The write value should always be 0.

Bit	Bit Name	Initial Value	R/W	Description
0	PB16MD	1	R/W*	PB16 Mode Select the function of the PB16/ $\overline{\text{POE3}}$ pin. 0: PB16 I/O (port) 1: $\overline{\text{POE3}}$ input (POE)

Note: * After a power-on reset, write can be performed only once. Rewrite must be performed when the POE function is selected as the initial value.

- Port B Control Register L2 (PBCRL2)

Bit:	15	14	13	12	11	10	9	8	7	6	5	4	3	2	1	0
	-	-	-	-	-	-	-	-	-	PB5 MD2	PB5 MD1	PB5 MD0	-	PB4 MD2	PB4 MD1	PB4 MD0
Initial value:	0	0	0	0	0	0	0	0	0	0	0	0	0	0	0	0
R/W:	R	R	R	R	R	R	R	R	R	R/W	R/W	R/W	R	R/W	R/W	R/W

Bit	Bit Name	Initial Value	R/W	Description
15 to 7	—	All 0	R	Reserved These bits are always read as 0. The write value should always be 0.
6	PB5MD2	0	R/W	PB5 Mode
5	PB5MD1	0	R/W	Select the function of the PB5/IRQ3/ $\overline{\text{POE5}}$ /TIC5U pin.
4	PB5MD0	0	R/W	000: PB5 I/O (port) 001: IRQ3 input (INTC) 011: TIC5U input (MTU2) 101: A19 output (BSC)* 111: $\overline{\text{POE5}}$ input (POE) Other than above: Setting prohibited
3	—	0	R	Reserved This bit is always read as 0. The write value should always be 0.

Bit	Bit Name	Initial Value	R/W	Description
2	PB4MD2	0	R/W	PB4 Mode
1	PB4MD1	0	R/W	Select the function of the PB4/IRQ2/ $\overline{POE4}$ /TIC5US pin.
0	PB4MD0	0	R/W	000: PB4 I/O (port) 001: IRQ2 input (INTC) 011: TIC5US input (MTU2S) 101: A18 output (BSC)* 111: $\overline{POE4}$ input (POE) Other than above: Setting prohibited

Note: * This function is enabled only in the on-chip ROM enabled/disabled external-extension mode. Do not set 1 in single-chip mode.

- Port B Control Register L1 (PBCRL1)

Bit:	15	14	13	12	11	10	9	8	7	6	5	4	3	2	1	0
	-	PB3 MD2	PB3 MD1	PB3 MD0	-	PB2 MD2	PB2 MD1	PB2 MD0	-	-	-	-	-	-	-	-
Initial value:	0	0	0	0	0	0	0	0	0	0	0	0	0	0	0	0
R/W:	R	R/W	R/W	R/W	R	R/W	R/W	R/W	R	R	R	R	R	R	R	R

Bit	Bit Name	Initial Value	R/W	Description
15	—	0	R	Reserved This bit is always read as 0. The write value should always be 0.
14	PB3MD2	0	R/W	PB3 Mode
13	PB3MD1	0	R/W	Select the function of the PB3/IRQ1/ $\overline{POE1}$ /TIC5V pin.
12	PB3MD0	0	R/W	000: PB3 I/O (port) 001: IRQ1 input (INTC) 010: $\overline{POE1}$ input (POE) 011: TIC5V input (MTU2) 101: A17 output (BSC) Other than above: Setting prohibited
11	—	0	R	Reserved This bit is always read as 0. The write value should always be 0.

Bit	Bit Name	Initial Value	R/W	Description
10	PB2MD2	0	R/W	PB2 Mode
9	PB2MD1	0	R/W	Select the function of the PB2/IRQ0/ $\overline{POE0}$ /TIC5VS pin.
8	PB2MD0	0	R/W	000: PB2 I/O (port) 001: IRQ0 input (INTC) 010: $\overline{POE0}$ input (POE) 011: TIC5VS input (MTU2S) 101: A16 output (BSC) Other than above: Setting prohibited
7 to 0	—	All 0	R	Reserved These bits are always read as 0. The write value should always be 0.

SH7149:

• Port B Control Register H1 (PBCRH1)

Bit:	15	14	13	12	11	10	9	8	7	6	5	4	3	2	1	0
	-	-	-	-	-	-	-	PB18 MD	-	-	-	PB17 MD	-	-	-	PB16 MD
Initial value:	0	0	0	0	0	0	0	1	0	0	0	1	0	0	0	1
R/W:	R	R	R	R	R	R	R	R/W*	R	R	R	R/W*	R	R	R	R/W*

Note: * After a power-on reset, write can be performed only once.
Rewrite must be performed when the POE function is selected as the initial value.

Bit	Bit Name	Initial Value	R/W	Description
15 to 9	—	All 0	R	Reserved These bits are always read as 0. The write value should always be 0.
8	PB18MD	1	R/W*	PB18 Mode Select the function of the PB18/ $\overline{POE8}$ pin. 0: PB18 I/O (port) 1: $\overline{POE8}$ input (POE)
7 to 5	—	All 0	R	Reserved These bits are always read as 0. The write value should always be 0.

Bit	Bit Name	Initial Value	R/W	Description
4	PB17MD	1	R/W*	PB17 Mode Select the function of the PB17/ $\overline{POE7}$ pin. 0: PB17 I/O (port) 1: $\overline{POE7}$ input (POE)
3 to 1	—	All 0	R	Reserved These bits are always read as 0. The write value should always be 0.
0	PB16MD	1	R/W*	PB16 Mode Select the function of the PB16/ $\overline{POE3}$ pin. 0: PB16 I/O (port) 1: $\overline{POE3}$ input (POE)

Note: * After a power-on reset, write can be performed only once. Rewrite must be performed when the POE function is selected as the initial value.

- Port B Control Register L2 (PBCRL2)

Bit:	15	14	13	12	11	10	9	8	7	6	5	4	3	2	1	0
	-	-	-	-	-	-	-	-	-	PB5 MD2	PB5 MD1	PB5 MD0	-	PB4 MD2	PB4 MD1	PB4 MD0
Initial value:	0	0	0	0	0	0	0	0	0	0	0	0	0	0	0	0
R/W:	R	R	R	R	R	R	R	R	R	R/W	R/W	R/W	R	R/W	R/W	R/W

Bit	Bit Name	Initial Value	R/W	Description
15 to 7	—	All 0	R	Reserved These bits are always read as 0. The write value should always be 0.
6	PB5MD2	0	R/W	PB5 Mode
5	PB5MD1	0	R/W	Select the function of the PB5/A19/ $\overline{IRQ3}$ / $\overline{POE5}$ / $\overline{TIC5U}$ pin.
4	PB5MD0	0	R/W	000: PB5 I/O (port) 001: $\overline{IRQ3}$ input (INTC) 011: $\overline{TIC5U}$ input (MTU2) 101: A19 output (BSC)* 111: $\overline{POE5}$ input (POE) Other than above: Setting prohibited

Bit	Bit Name	Initial Value	R/W	Description
3	—	0	R	Reserved This bit is always read as 0. The write value should always be 0.
2	PB4MD2	0	R/W	PB4 Mode
1	PB4MD1	0	R/W	Select the function of the PB4/A18/IRQ2/POE4/TIC5US pin.
0	PB4MD0	0	R/W	000: PB4 I/O (port) 001: IRQ2 input (INTC) 011: TIC5US input (MTU2S) 101: A18 output (BSC)* 111: $\overline{\text{POE4}}$ input (POE) Other than above: Setting prohibited

Note: * This function is enabled only in the on-chip ROM enabled/disabled external-extension mode. Do not set 1 in single-chip mode.

- Port B Control Register L1 (PBCRL1)

Bit:	15	14	13	12	11	10	9	8	7	6	5	4	3	2	1	0
	-	PB3 MD2	PB3 MD1	PB3 MD0	-	PB2 MD2	PB2 MD1	PB2 MD0	-	PB1 MD2	PB1 MD1	PB1 MD0	-	PB0 MD2	PB0 MD1	PB0 MD0
Initial value:	0	0*	0	0*	0	0*	0	0*	0	0	0	0	0	0	0	0
R/W:	R	R/W	R/W	R/W	R	R/W	R/W	R/W	R	R/W	R/W	R/W	R	R/W	R/W	R/W

Note: * The initial value is 1 in the on-chip ROM disabled external-extension mode.

Bit	Bit Name	Initial Value	R/W	Description
15	—	0	R	Reserved This bit is always read as 0. The write value should always be 0.
14	PB3MD2	0* ¹	R/W	PB3 Mode
13	PB3MD1	0	R/W	Select the function of the PB3/A17/IRQ1/ $\overline{\text{POE1}}$ /TIC5V pin.
12	PB3MD0	0* ¹	R/W	000: PB3 I/O (port) 001: IRQ1 input (INTC) 010: $\overline{\text{POE1}}$ input (POE) 011: TIC5V input (MTU2) 101: A17 output (BSC)* ² Other than above: Setting prohibited

Bit	Bit Name	Initial Value	R/W	Description
11	—	0	R	Reserved This bit is always read as 0. The write value should always be 0.
10	PB2MD2	0* ¹	R/W	PB2 Mode
9	PB2MD1	0	R/W	Select the function of the PB2/A16/IRQ0/POE0/TIC5VS pin.
8	PB2MD0	0* ¹	R/W	000: PB2 I/O (port) 001: IRQ0 input (INTC) 010: $\overline{POE0}$ input (POE) 011: TIC5VS input (MTU2S) 101: A16 output (BSC)* ² Other than above: Setting prohibited
7	—	0	R	Reserved This bit is always read as 0. The write value should always be 0.
6	PB1MD2	0	R/W	PB1 Mode
5	PB1MD1	0	R/W	Select the function of the PB1/ \overline{BREQ} /TIC5W pin.
4	PB1MD0	0	R/W	000: PB1 I/O (port) 011: TIC5W input (MTU2) 101: \overline{BREQ} input (BSC)* ² Other than above: Setting prohibited
3	—	0	R	Reserved This bit is always read as 0. The write value should always be 0.
2	PB0MD2	0	R/W	PB0 Mode
1	PB0MD1	0	R/W	Select the function of the PB0/ \overline{BACK} /TIC5WS pin.
0	PB0MD0	0	R/W	000: PB0 I/O (port) 011: TIC5WS input (MTU2S) 101: \overline{BACK} output (BSC)* ² Other than above: Setting prohibited

- Notes: 1. The initial value is 1 in the on-chip ROM disabled external-extension mode.
2. This function is enabled only in the on-chip ROM enabled/disabled external-extension mode. Do not set 1 in single-chip mode.

17.1.5 Port D I/O Register L (PDIORL) (SH7149 Only)

PDIORL is a 16-bit readable/writable register that is used to set the pins on port D as inputs or outputs. Bits PD15IOR to PD0IOR correspond to pins PD15 to PD0 (names of multiplexed pins are here given as port names and pin numbers alone). PDIORL is enabled when the port D pins are functioning as general-purpose inputs/outputs (PD15 to PD0). In other states, PDIORL is disabled.

A given pin on port D will be an output pin if the corresponding bit in PDIORL is set to 1, and an input pin if the bit is cleared to 0.

However, PDIORL is disabled in SH7146.

The initial value of PDIORL is H'0000.

Bit:	15	14	13	12	11	10	9	8	7	6	5	4	3	2	1	0
	PD15 IOR	PD14 IOR	PD13 IOR	PD12 IOR	PD11 IOR	PD10 IOR	PD9 IOR	PD8 IOR	PD7 IOR	PD6 IOR	PD5 IOR	PD4 IOR	PD3 IOR	PD2 IOR	PD1 IOR	PD0 IOR
Initial value:	0	0	0	0	0	0	0	0	0	0	0	0	0	0	0	0
R/W:	R/W	R/W	R/W	R/W	R/W	R/W	R/W	R/W	R/W	R/W	R/W	R/W	R/W	R/W	R/W	R/W

17.1.6 Port D Control Registers L1 to L4 (PDCRL1 to PDCRL4) (SH7149 Only)

PDCRL1 to PDCRL4 are 16-bit readable/writable registers that are used to select the functions of the multiplexed pins on port D. However, PDCRL1 to PDCRL4 are disabled in SH7146.

- Port D Control Register L4 (PDCRL4)

Bit:	15	14	13	12	11	10	9	8	7	6	5	4	3	2	1	0
	-	-	PD15 MD1	PD15 MD0	-	-	PD14 MD1	PD14 MD0	-	-	PD13 MD1	PD13 MD0	-	-	PD12 MD1	PD12 MD0
Initial value:	0	0	0	0*	0	0	0	0*	0	0	0	0*	0	0	0	0*
R/W:	R	R	R/W	R/W	R	R	R/W	R/W	R	R	R/W	R/W	R	R	R/W	R/W

Note: * The initial value is 1 in the on-chip ROM disabled 16-bit external-extension mode.

Bit	Bit Name	Initial Value	R/W	Description
15, 14	—	All 0	R	Reserved These bits are always read as 0. The write value should always be 0.

Bit	Bit Name	Initial Value	R/W	Description
13	PD15MD1	0	R/W	PD15 Mode
12	PD15MD0	0* ¹	R/W	Select the function of the PD15/D15/AUDSYN \bar{C} pin. Fixed to AUDSYN \bar{C} output when using the AUD function of E10A. 00: PD15 I/O (port) 01: D15 I/O (BSC)* ² Other than above: Setting prohibited
11, 10	—	All 0	R	Reserved These bits are always read as 0. The write value should always be 0.
9	PD14MD1	0	R/W	PD14 Mode
8	PD14MD0	0* ¹	R/W	Select the function of the PD14/D14/AUDCK pin. Fixed to AUDCK output when using the AUD function of E10A. 00: PD14 I/O (port) 01: D14 I/O (BSC)* ² Other than above: Setting prohibited
7, 6	—	All 0	R	Reserved These bits are always read as 0. The write value should always be 0.
5	PD13MD1	0	R/W	PD13 Mode
4	PD13MD0	0* ¹	R/W	Select the function of the PD13/D13 pin. 00: PD13 I/O (port) 01: D13 I/O (BSC)* ² Other than above: Setting prohibited
3, 2	—	All 0	R	Reserved These bits are always read as 0. The write value should always be 0.

Bit	Bit Name	Initial Value	R/W	Description
1	PD12MD1	0	R/W	PD12 Mode
0	PD12MD0	0* ¹	R/W	Select the function of the PD12/D12 pin. 00: PD12 I/O (port) 01: D12 I/O (BSC)* ² Other than above: Setting prohibited

Notes: 1. The initial value is 1 in the on-chip ROM disabled 16-bit external-extension mode.
2. This function is enabled in the on-chip ROM enabled/disabled external-extension mode. Do not set 1 in single-chip mode.

- Port D Control Register L3 (PDCRL3)

Bit:	15	14	13	12	11	10	9	8	7	6	5	4	3	2	1	0
	-	-	PD11 MD1	PD11 MD0	-	PD10 MD2	PD10 MD1	PD10 MD0	-	PD9 MD2	PD9 MD1	PD9 MD0	-	PD8 MD2	PD8 MD1	PD8 MD0
Initial value:	0	0	0	0*	0	0	0	0*	0	0	0	0*	0	0	0	0*
R/W:	R	R	R/W	R/W	R	R/W	R/W	R/W	R	R/W	R/W	R/W	R	R/W	R/W	R/W

Note: * The initial value is 1 in the on-chip ROM disabled 16-bit external-extension mode.

Bit	Bit Name	Initial Value	R/W	Description
15, 14	—	All 0	R	Reserved These bits are always read as 0. The write value should always be 0.
13	PD11MD1	0	R/W	PD11 Mode
12	PD11MD0	0* ¹	R/W	Select the function of the PD11/D11/AUDATA3 pin. Fixed to AUDATA3 output when using the AUD function of E10A. 00: PD11 I/O (port) 01: D11 I/O (BSC)* ² Other than above: Setting prohibited
11	—	0	R	Reserved This bit is always read as 0. The write value should always be 0.

Bit	Bit Name	Initial Value	R/W	Description
10	PD10MD2	0	R/W	PD10 Mode
9	PD10MD1	0	R/W	Select the function of the PD10/D10/AUDATA2 pin.
8	PD10MD0	0* ¹	R/W	Fixed to AUDATA2 output when using the AUD function of E10A. 000: PD10 I/O (port) 001: D10 I/O (BSC)* ² Other than above: Setting prohibited
7	—	0	R	Reserved This bit is always read as 0. The write value should always be 0.
6	PD9MD2	0	R/W	PD9 Mode
5	PD9MD1	0	R/W	Select the function of the PD9/D9/AUDATA1 pin.
4	PD9MD0	0* ¹	R/W	Fixed to AUDATA1 output when using the AUD function of E10A. 000: PD9 I/O (port) 001: D9 I/O (BSC)* ² Other than above: Setting prohibited
3	—	0	R	Reserved This bit is always read as 0. The write value should always be 0.
2	PD8MD2	0	R/W	PD8 Mode
1	PD8MD1	0	R/W	Select the function of the PD8/D8/SCK2/AUDATA0 pin. Fixed to AUDATA0 output when using the AUD function of E10A.
0	PD8MD0	0* ¹	R/W	000: PD8 I/O (port) 001: D8 I/O (BSC)* ² 110: SCK2 I/O (SCI) Other than above: Setting prohibited

- Notes: 1. The initial value is 1 in the on-chip ROM disabled 16-bit external-extension mode.
2. This function is enabled only in the on-chip ROM enabled/disabled external-extension mode. Do not set 1 in single-chip mode.

- Port D Control Register L2 (PDCRL2)

Bit:	15	14	13	12	11	10	9	8	7	6	5	4	3	2	1	0
	-	PD7 MD2	PD7 MD1	PD7 MD0	-	PD6 MD2	PD6 MD1	PD6 MD0	-	PD5 MD2	PD5 MD1	PD5 MD0	-	PD4 MD2	PD4 MD1	PD4 MD0
Initial value:	0	0	0	0*	0	0	0	0*	0	0	0	0*	0	0	0	0*
R/W:	R	R/W	R/W	R/W	R	R/W	R/W	R/W	R	R/W	R/W	R/W	R	R/W	R/W	R/W

Note: * The initial value is 1 in the on-chip ROM disabled external-extension mode.

Bit	Bit Name	Initial Value	R/W	Description
15	—	0	R	Reserved This bit is always read as 0. The write value should always be 0.
14	PD7MD2	0	R/W	PD7 Mode
13	PD7MD1	0	R/W	Select the function of the PD7/D7/IRQ3/TXD2 pin.
12	PD7MD0	0* ¹	R/W	000: PD7 I/O (port) 001: D7 I/O (BSC)* ² 100: IRQ3 input (INTC) 110: TXD2 output (SCI) Other than above: Setting prohibited
11	—	0	R	Reserved This bit is always read as 0. The write value should always be 0.
10	PD6MD2	0	R/W	PD6 Mode
9	PD6MD1	0	R/W	Select the function of the PD6/D6/IRQ2/RXD2 pin.
8	PD6MD0	0* ¹	R/W	000: PD6 I/O (port) 001: D6 I/O (BSC)* ² 100: IRQ2 input (INTC) 110: RXD2 input (SCI) Other than above: Setting prohibited
7	—	0	R	Reserved This bit is always read as 0. The write value should always be 0.

Bit	Bit Name	Initial Value	R/W	Description
6	PD5MD2	0	R/W	PD5 Mode
5	PD5MD1	0	R/W	Select the function of the PD5/D5/IRQ1/SCK1 pin.
4	PD5MD0	0* ¹	R/W	000: PD5 I/O (port) 001: D5 I/O (BSC)* ² 100: IRQ1 input (INTC) 110: SCK1 I/O (SCI) Other than above: Setting prohibited
3	—	0	R	Reserved This bit is always read as 0. The write value should always be 0.
2	PD4MD2	0	R/W	PD4 Mode
1	PD4MD1	0	R/W	Select the function of the PD4/D4/IRQ0/TXD1 pin.
0	PD4MD0	0* ¹	R/W	000: PD4 I/O (port) 001: D4 I/O (BSC)* ² 100: IRQ0 input (INTC) 110: TXD1 output (SCI) Other than above: Setting prohibited

Notes: 1. The initial value is 1 in the on-chip ROM disabled external-extension mode.

2. This function is enabled only in the on-chip ROM enabled/disabled external-extension mode. Do not set 1 in single-chip mode.

- Port D Control Register L1 (PDCRL1)

Bit:	15	14	13	12	11	10	9	8	7	6	5	4	3	2	1	0
	-	PD3 MD2	PD3 MD1	PD3 MD0	-	PD2 MD2	PD2 MD1	PD2 MD0	-	PD1 MD2	PD1 MD1	PD1 MD0	-	PD0 MD2	PD0 MD1	PD0 MD0
Initial value:	0	0	0	0*	0	0	0	0*	0	0	0	0*	0	0	0	0*
R/W:	R	R/W	R/W	R/W	R	R/W	R/W	R/W	R	R/W	R/W	R/W	R	R/W	R/W	R/W

Note: * The initial value is 1 in the on-chip ROM disabled external-extension mode.

Bit	Bit Name	Initial Value	R/W	Description
15	—	0	R	Reserved This bit is always read as 0. The write value should always be 0.

Bit	Bit Name	Initial Value	R/W	Description
14	PD3MD2	0	R/W	PD3 Mode
13	PD3MD1	0	R/W	Select the function of the PD3/D3/RXD1 pin.
12	PD3MD0	0* ¹	R/W	000: PD3 I/O (port) 001: D3 I/O (BSC)* ² 110: RXD1 input (SCI) Other than above: Setting prohibited
11	—	0	R	Reserved This bit is always read as 0. The write value should always be 0.
10	PD2MD2	0	R/W	PD2 Mode
9	PD2MD1	0	R/W	Select the function of the PD2/D2/SCK0 pin.
8	PD2MD0	0* ¹	R/W	000: PD2 I/O (port) 001: D2 I/O (BSC)* ² 110: SCK0 I/O (SCI) Other than above: Setting prohibited
7	—	0	R	Reserved This bit is always read as 0. The write value should always be 0.
6	PD1MD2	0	R/W	PD1 Mode
5	PD1MD1	0	R/W	Select the function of the PD1/D1/TXD0 pin.
4	PD1MD0	0* ¹	R/W	000: PD1 I/O (port) 001: D1 I/O (BSC)* ² 110: TXD0 output (SCI) Other than above: Setting prohibited
3	—	0	R	Reserved This bit is always read as 0. The write value should always be 0.
2	PD0MD2	0	R/W	PD0 Mode
1	PD0MD1	0	R/W	Select the function of the PD0/D0/RXD0 pin.
0	PD0MD0	0* ¹	R/W	000: PD0 I/O (port) 001: D0 I/O (BSC)* ² 110: RXD0 input (SCI) Other than above: Setting prohibited

- Notes: 1. The initial value is 1 in the on-chip ROM disabled external-extension mode.
2. This function is enabled only in the on-chip ROM enabled/disabled external-extension mode. Do not set 1 in single-chip mode.

17.1.7 Port E I/O Registers L, H (PEIORL, PEIORH)

PEIORL and PEIORH are 16-bit readable/writable registers that are used to set the pins on port E as inputs or outputs. PE21IOR to PE0IOR correspond to pins PE21 to PE0 (names of multiplexed pins are here given as port names and pin numbers alone). PEIORL is enabled when the port E pins are functioning as general-purpose inputs/outputs (PE15 to PE0), and the TIOC pin is functioning as inputs/outputs of MTU2. In other states, PEIORL is disabled. PEIORH is enabled when the port E pins are functioning as general-purpose inputs/outputs (PE21 to PE16), and the TIOC pin is functioning as inputs/outputs of MTU2S. In other states, PEIORH is disabled.

A given pin on port E will be an output pin if the corresponding bit in PEIORH or PEIORL is set to 1, and an input pin if the bit is cleared to 0.

Bits 15 to 6 of PEIORH are reserved. These bits are always read as 0. The write value should always be 0.

The initial values of PEIORL and PEIORH are H'0000, respectively.

- Port E I/O Register H (PEIORH)

Bit:	15	14	13	12	11	10	9	8	7	6	5	4	3	2	1	0
	-	-	-	-	-	-	-	-	-	-	PE21 IOR	PE20 IOR	PE19 IOR	PE18 IOR	PE17 IOR	PE16 IOR
Initial value:	0	0	0	0	0	0	0	0	0	0	0	0	0	0	0	0
R/W:	R	R	R	R	R	R	R	R	R	R	R/W	R/W	R/W	R/W	R/W	R/W

- Port E I/O Register L (PEIORL)

Bit:	15	14	13	12	11	10	9	8	7	6	5	4	3	2	1	0
	PE15 IOR	PE14 IOR	PE13 IOR	PE12 IOR	PE11 IOR	PE10 IOR	PE9 IOR	PE8 IOR	PE7 IOR	PE6 IOR	PE5 IOR	PE4 IOR	PE3 IOR	PE2 IOR	PE1 IOR	PE0 IOR
Initial value:	0	0	0	0	0	0	0	0	0	0	0	0	0	0	0	0
R/W:	R/W	R/W	R/W	R/W	R/W	R/W	R/W	R/W	R/W	R/W	R/W	R/W	R/W	R/W	R/W	R/W

17.1.8 Port E Control Registers L1 to L4, H1, H2 (PECRL1 to PECRL4, PECRH1, PECRH2)

PECRL1 to PECRL4, PECRH1 and PECRH2 are 16-bit readable/writable registers that are used to select the functions of the multiplexed pins on port E.

SH7146:

- Port E Control Register H2 (PECRH2)

Bit:	15	14	13	12	11	10	9	8	7	6	5	4	3	2	1	0
	-	-	-	-	-	-	-	-	-	-	PE21 MD1	PE21 MD0	-	-	PE20 MD1	PE20 MD0
Initial value:	0	0	0	0	0	0	0	0	0	0	0	0	0	0	0	0
R/W:	R	R	R	R	R	R	R	R	R	R	R/W	R/W	R	R	R/W	R/W

Bit	Bit Name	Initial Value	R/W	Description
15 to 6	—	All 0	R	Reserved These bits are always read as 0. The write value should always be 0.
5	PE21MD1	0	R/W	PE21 Mode
4	PE21MD0	0	R/W	Select the function of the PE21/TIOC4DS/TRST pin. For the F-ZTAT version, fixed to TRST input when using E10A (in ASEMD0 = low). 00: PE21 I/O (port) 01: TIOC4DS I/O (MTU2S) Other than above: Setting prohibited
3, 2	—	All 0	R	Reserved These bits are always read as 0. The write value should always be 0.
1	PE20MD1	0	R/W	PE20 Mode
0	PE20MD0	0	R/W	Select the function of the PE20/TIOC4CS/TMS pin. For the F-ZTAT version, fixed to TMS input when using E10A (in ASEMD0 = low). 00: PE20 I/O (port) 01: TIOC4CS I/O (MTU2S) Other than above: Setting prohibited

- Port E Control Register H1 (PECRH1)

Bit:	15	14	13	12	11	10	9	8	7	6	5	4	3	2	1	0
	-	-	PE19 MD1	PE19 MD0	-	-	PE18 MD1	PE18 MD0	-	-	PE17 MD1	PE17 MD0	-	PE16 MD2	PE16 MD1	PE16 MD0
Initial value:	0	0	0	0	0	0	0	0	0	0	0	0	0	0	0	0
R/W:	R	R	R/W	R/W	R	R	R/W	R/W	R	R	R/W	R/W	R	R/W	R/W	R/W

Bit	Bit Name	Initial Value	R/W	Description
15, 14	—	All 0	R	Reserved These bits are always read as 0. The write value should always be 0.
13	PE19MD1	0	R/W	PE19 Mode
12	PE19MD0	0	R/W	Select the function of the PE19/TIOC4BS/TDO pin. For the F-ZTAT version, fixed to TDO output when using E10A (in $\overline{ASEMD0}$ = low). 00: PE19 I/O (port) 01: TIOC4BS I/O (MTU2S) Other than above: Setting prohibited
11, 10	—	All 0	R	Reserved These bits are always read as 0. The write value should always be 0.
9	PE18MD1	0	R/W	PE18 Mode
8	PE18MD0	0	R/W	Select the function of the PE18/TIOC4AS/TDI pin. For the F-ZTAT version, fixed to TDI input when using E10A (in $\overline{ASEMD0}$ = low). 00: PE18 I/O (port) 01: TIOC4AS I/O (MTU2S) Other than above: Setting prohibited
7, 6	—	All 0	R	Reserved These bits are always read as 0. The write value should always be 0.

Bit	Bit Name	Initial Value	R/W	Description
5	PE17MD1	0	R/W	PE17 Mode
4	PE17MD0	0	R/W	Select the function of the PE17/TIOC3DS/TCK pin. For the F-ZTAT version, fixed to TCK input when using E10A (in ASEMD0 = low). 00: PE17 I/O (port) 01: TIOC3DS I/O (MTU2S) Other than above: Setting prohibited
3	—	0	R	Reserved This bit is always read as 0. The write value should always be 0.
2	PE16MD2	0	R/W	PE16 Mode
1	PE16MD1	0	R/W	Select the function of the
0	PE16MD0	0	R/W	PE16/TIOC3BS/ASEBRKAK/ASEBRK pin. For the F-ZTAT version, fixed to ASEBRKAK output/ASEBRK input when using E10A (in ASEMD0 = low). 000: PE16 I/O (port) 001: TIOC3BS I/O (MTU2S) Other than above: Setting prohibited

- Port E Control Register L4 (PECRL4)

Bit:	15	14	13	12	11	10	9	8	7	6	5	4	3	2	1	0
	-	PE15 MD2	PE15 MD1	PE15 MD0	-	PE14 MD2	PE14 MD1	PE14 MD0	-	-	PE13 MD1	PE13 MD0	-	PE12 MD2	PE12 MD1	PE12 MD0
Initial value:	0	0	0	0	0	0	0	0	0	0	0	0	0	0	0	0
R/W:	R	R/W	R/W	R/W	R	R/W	R/W	R/W	R	R	R/W	R/W	R	R/W	R/W	R/W

Bit	Bit Name	Initial Value	R/W	Description
15	—	0	R	Reserved This bit is always read as 0. The write value should always be 0.

Bit	Bit Name	Initial Value	R/W	Description
14	PE15MD2	0	R/W	PE15 Mode
13	PE15MD1	0	R/W	Select the function of the PE15/TIOC4D/ $\overline{\text{IRQOUT}}$ pin.
12	PE15MD0	0	R/W	000: PE15 I/O (port) 001: TIOC4D I/O (MTU2) 011: $\overline{\text{IRQOUT}}$ output (INTC) Other than above: Setting prohibited
11	—	0	R	Reserved This bit is always read as 0. The write value should always be 0.
10	PE14MD2	0	R/W	PE14 Mode
9	PE14MD1	0	R/W	Select the function of the PE14/TIOC4C pin.
8	PE14MD0	0	R/W	000: PE14 I/O (port) 001: TIOC4C I/O (MTU2) Other than above: Setting prohibited
7, 6	—	All 0	R	Reserved These bits are always read as 0. The write value should always be 0.
5	PE13MD1	0	R/W	PE13 Mode
4	PE13MD0	0	R/W	Select the function of the PE13/TIOC4B/ $\overline{\text{MRES}}$ pin. 00: PE13 I/O (port) 01: TIOC4B I/O (MTU2) 10: $\overline{\text{MRES}}$ input (INTC) Other than above: Setting prohibited
3	—	0	R	Reserved This bit is always read as 0. The write value should always be 0.
2	PE12MD2	0	R/W	PE12 Mode
1	PE12MD1	0	R/W	Select the function of the PE12/TIOC4A pin.
0	PE12MD0	0	R/W	000: PE12 I/O (port) 001: TIOC4A I/O (MTU2) Other than above: Setting prohibited

- Port E Control Register L3 (PECRL3)

Bit:	15	14	13	12	11	10	9	8	7	6	5	4	3	2	1	0
	-	PE11 MD2	PE11 MD1	PE11 MD0	-	PE10 MD2	PE10 MD1	PE10 MD0	-	PE9 MD2	PE9 MD1	PE9 MD0	-	PE8 MD2	PE8 MD1	PE8 MD0
Initial value:	0	0	0	0	0	0	0	0	0	0	0	0	0	0	0	0
R/W:	R	R/W	R/W	R/W	R	R/W	R/W	R/W	R	R/W	R/W	R/W	R	R/W	R/W	R/W

Bit	Bit Name	Initial Value	R/W	Description
15	—	0	R	Reserved This bit is always read as 0. The write value should always be 0.
14	PE11MD2	0	R/W	PE11 Mode
13	PE11MD1	0	R/W	Select the function of the PE11/TIOC3D pin.
12	PE11MD0	0	R/W	000: PE11 I/O (port) 001: TIOC3D I/O (MTU2) Other than above: Setting prohibited
11	—	0	R	Reserved This bit is always read as 0. The write value should always be 0.
10	PE10MD2	0	R/W	PE10 Mode
9	PE10MD1	0	R/W	Select the function of the PE10/TIOC3C pin.
8	PE10MD0	0	R/W	000: PE10 I/O (port) 001: TIOC3C I/O (MTU2) Other than above: Setting prohibited
7	—	0	R	Reserved This bit is always read as 0. The write value should always be 0.
6	PE9MD2	0	R/W	PE9 Mode
5	PE9MD1	0	R/W	Select the function of the PE9/TIOC3B pin.
4	PE9MD0	0	R/W	000: PE9 I/O (port) 001: TIOC3B I/O (MTU2) Other than above: Setting prohibited
3	—	0	R	Reserved This bit is always read as 0. The write value should always be 0.

Bit	Bit Name	Initial Value	R/W	Description
2	PE8MD2	0	R/W	PE8 Mode
1	PE8MD1	0	R/W	Select the function of the PE8/TIOC3A pin.
0	PE8MD0	0	R/W	000: PE8 I/O (port) 001: TIOC3A I/O (MTU2) Other than above: Setting prohibited

- Port E Control Register L2 (PECRL2)

Bit:	15	14	13	12	11	10	9	8	7	6	5	4	3	2	1	0
	-	PE7 MD2	PE7 MD1	PE7 MD0	-	PE6 MD2	PE6 MD1	PE6 MD0	-	PE5 MD2	PE5 MD1	PE5 MD0	-	PE4 MD2	PE4 MD1	PE4 MD0
Initial value:	0	0	0	0	0	0	0	0	0	0	0	0	0	0	0	0
R/W:	R	R/W	R/W	R/W	R	R/W	R/W	R/W	R	R/W	R/W	R/W	R	R/W	R/W	R/W

Bit	Bit Name	Initial Value	R/W	Description
15	—	0	R	Reserved This bit is always read as 0. The write value should always be 0.
14	PE7MD2	0	R/W	PE7 Mode
13	PE7MD1	0	R/W	Select the function of the PE7/TIOC2B pin.
12	PE7MD0	0	R/W	000: PE7 I/O (port) 001: TIOC2B I/O (MTU2) Other than above: Setting prohibited
11	—	0	R	Reserved This bit is always read as 0. The write value should always be 0.
10	PE6MD2	0	R/W	PE6 Mode
9	PE6MD1	0	R/W	Select the function of the PE6/TIOC2A/SCK1 pin.
8	PE6MD0	0	R/W	000: PE6 I/O (port) 001: TIOC2A I/O (MTU2) 110: SCK1 I/O (SCI) Other than above: Setting prohibited
7	—	0	R	Reserved This bit is always read as 0. The write value should always be 0.

Bit	Bit Name	Initial Value	R/W	Description
6	PE5MD2	0	R/W	PE5 Mode
5	PE5MD1	0	R/W	Select the function of the PE5/TIOC1B/TXD1 pin.
4	PE5MD0	0	R/W	000: PE5 I/O (port) 001: TIOC1B I/O (MTU2) 110: TXD1 output (SCI) Other than above: Setting prohibited
3	—	0	R	Reserved This bit is always read as 0. The write value should always be 0.
2	PE4MD2	0	R/W	PE4 Mode
1	PE4MD1	0	R/W	Select the function of the PE4/TIOC1A/RXD1 pin.
0	PE4MD0	0	R/W	000: PE4 I/O (port) 001: TIOC1A I/O (MTU2) 110: RXD1 input (SCI) Other than above: Setting prohibited

- Port E Control Register L1 (PECRL1)

Bit:	15	14	13	12	11	10	9	8	7	6	5	4	3	2	1	0
	-	PE3 MD2	PE3 MD1	PE3 MD0	-	PE2 MD2	PE2 MD1	PE2 MD0	-	PE1 MD2	PE1 MD1	PE1 MD0	-	-	PE0 MD1	PE0 MD0
Initial value:	0	0	0	0	0	0	0	0	0	0	0	0	0	0	0	0
R/W:	R	R/W	R/W	R/W	R	R/W	R/W	R/W	R	R/W	R/W	R/W	R	R	R/W	R/W

Bit	Bit Name	Initial Value	R/W	Description
15	—	0	R	Reserved This bit is always read as 0. The write value should always be 0.
14	PE3MD2	0	R/W	PE3 Mode
13	PE3MD1	0	R/W	Select the function of the PE3/TIOC0D/SCK0 pin.
12	PE3MD0	0	R/W	000: PE3 I/O (port) 001: TIOC0D I/O (MTU2) 110: SCK0 I/O (SCI) Other than above: Setting prohibited

Bit	Bit Name	Initial Value	R/W	Description
11	—	0	R	Reserved This bit is always read as 0. The write value should always be 0.
10	PE2MD2	0	R/W	PE2 Mode
9	PE2MD1	0	R/W	Select the function of the PE2/TIOC0C/TXD0 pin.
8	PE2MD0	0	R/W	000: PE2 I/O (port) 001: TIOC0C I/O (MTU2) 110: TXD0 output (SCI) Other than above: Setting prohibited
7	—	0	R	Reserved This bit is always read as 0. The write value should always be 0.
6	PE1MD2	0	R/W	PE1 Mode
5	PE1MD1	0	R/W	Select the function of the PE1/TIOC0B/RXD0 pin.
4	PE1MD0	0	R/W	000: PE1 I/O (port) 001: TIOC0B I/O (MTU2) 110: RXD0 input (SCI) Other than above: Setting prohibited
3, 2	—	All 0	R	Reserved These bits are always read as 0. The write value should always be 0.
1	PE0MD1	0	R/W	PE0 Mode
0	PE0MD0	0	R/W	Select the function of the PE0/TIOC0A pin. 00: PE0 I/O (port) 01: TIOC0A I/O (MTU2) Other than above: Setting prohibited

SH7149:

- Port E Control Register H2 (PECRH2)

Bit:	15	14	13	12	11	10	9	8	7	6	5	4	3	2	1	0
	-	-	-	-	-	-	-	-	-	-	PE21 MD1	PE21 MD0	-	-	PE20 MD1	PE20 MD0
Initial value:	0	0	0	0	0	0	0	0	0	0	0	0	0	0	0	0
R/W:	R	R	R	R	R	R	R	R	R	R	R/W	R/W	R	R	R/W	R/W

Bit	Bit Name	Initial Value	R/W	Description
15 to 6	—	All 0	R	Reserved These bits are always read as 0. The write value should always be 0.
5	PE21MD1	0	R/W	PE21 Mode
4	PE21MD0	0	R/W	Select the function of the PE21/ $\overline{\text{WRL}}$ /TIOC4DS/ $\overline{\text{TRST}}$ pin. For the F-ZTAT version, fixed to $\overline{\text{TRST}}$ input when using E10A (in $\overline{\text{ASEMD0}}$ = low). 00: PE21 I/O (port) 01: TIOC4DS I/O (MTU2S) 10: $\overline{\text{WRL}}$ output (BSC)* Other than above: Setting prohibited
3, 2	—	All 0	R	Reserved These bits are always read as 0. The write value should always be 0.
1	PE20MD1	0	R/W	PE20 Mode
0	PE20MD0	0	R/W	Select the function of the PE20/ $\overline{\text{WRH}}$ /TIOC4CS/TMS pin. For the F-ZTAT version, fixed to TMS input when using E10A (in $\overline{\text{ASEMD0}}$ = low). 00: PE20 I/O (port) 01: TIOC4CS I/O (MTU2S) 10: $\overline{\text{WRH}}$ output (BSC)* Other than above: Setting prohibited

Note: * This function is enabled only in the on-chip ROM enabled/disabled external-extension mode. Do not set 1 in single-chip mode.

- Port E Control Register H1 (PECRH1)

Bit:	15	14	13	12	11	10	9	8	7	6	5	4	3	2	1	0
	-	-	PE19 MD1	PE19 MD0	-	-	PE18 MD1	PE18 MD0	-	-	PE17 MD1	PE17 MD0	-	PE16 MD2	PE16 MD1	PE16 MD0
Initial value:	0	0	0	0	0	0	0	0	0	0	0	0	0	0	0	0
R/W:	R	R	R/W	R/W	R	R	R/W	R/W	R	R	R/W	R/W	R	R/W	R/W	R/W

Bit	Bit Name	Initial Value	R/W	Description
15, 14	—	All 0	R	Reserved These bits are always read as 0. The write value should always be 0.
13	PE19MD1	0	R/W	PE19 Mode
12	PE19MD0	0	R/W	Select the function of the PE19/ \overline{RD} /TIOC4BS/TDO pin. For the F-ZTAT version, fixed to TDO output when using E10A (in $\overline{ASEMD0}$ = low). 00: PE19 I/O (port) 01: TIOC4BS I/O (MTU2S) 10: \overline{RD} output (BSC)* Other than above: Setting prohibited
11, 10	—	All 0	R	Reserved These bits are always read as 0. The write value should always be 0.
9	PE18MD1	0	R/W	PE18 Mode
8	PE18MD0	0	R/W	Select the function of the PE18/ $\overline{CS1}$ /TIOC4AS/TDI pin. For the F-ZTAT version, fixed to TDI input when using E10A (in $\overline{ASEMD0}$ = low). 00: PE18 I/O (port) 01: TIOC4AS I/O (MTU2S) 10: $\overline{CS1}$ output (BSC)* Other than above: Setting prohibited
7, 6	—	All 0	R	Reserved These bits are always read as 0. The write value should always be 0.

Bit	Bit Name	Initial Value	R/W	Description
5	PE17MD1	0	R/W	PE17 Mode
4	PE17MD0	0	R/W	Select the function of the PE17/ $\overline{CS0}$ /TIOC3DS/TCK pin. For the F-ZTAT version, fixed to TCK input when using E10A (in $\overline{ASEMD0}$ = low). 00: PE17 I/O (port) 01: TIOC3DS I/O (MTU2S) 10: $\overline{CS0}$ output (BSC)* Other than above: Setting prohibited
3	—	0	R	Reserved This bit is always read as 0. The write value should always be 0.
2	PE16MD2	0	R/W	PE16 Mode
1	PE16MD1	0	R/W	Select the function of the
0	PE16MD0	0	R/W	PE16/ \overline{WAIT} /TIOC3BS/ $\overline{ASEBRKAK}$ / \overline{ASEBRK} pin. For the F-ZTAT version, fixed to $\overline{ASEBRKAK}$ output/ \overline{ASEBRK} input when using E10A (in $\overline{ASEMD0}$ = low). 000: PE16 I/O (port) 001: TIOC3BS I/O (MTU2S) 010: \overline{WAIT} input (BSC)* Other than above: Setting prohibited

Note: * This function is enabled only in the on-chip ROM enabled/disabled external-extension mode. Do not set 1 in single-chip mode.

- Port E Control Register L4 (PECRL4)

Bit:	15	14	13	12	11	10	9	8	7	6	5	4	3	2	1	0
	-	PE15 MD2	PE15 MD1	PE15 MD0	-	PE14 MD2	PE14 MD1	PE14 MD0	-	-	PE13 MD1	PE13 MD0	-	PE12 MD2	PE12 MD1	PE12 MD0
Initial value:	0	0	0	0	0	0	0	0	0	0	0	0	0	0	0	0
R/W:	R	R/W	R/W	R/W	R	R/W	R/W	R/W	R	R	R/W	R/W	R	R/W	R/W	R/W

Bit	Bit Name	Initial Value	R/W	Description
15	—	0	R	Reserved This bit is always read as 0. The write value should always be 0.

Bit	Bit Name	Initial Value	R/W	Description
14	PE15MD2	0	R/W	PE15 Mode
13	PE15MD1	0	R/W	Select the function of the PE15/TIOC4D/ $\overline{\text{IRQOUT}}$ pin.
12	PE15MD0	0	R/W	000: PE15 I/O (port) 001: TIOC4D I/O (MTU2) 011: $\overline{\text{IRQOUT}}$ output (INTC) Other than above: Setting prohibited
11	—	0	R	Reserved This bit is always read as 0. The write value should always be 0.
10	PE14MD2	0	R/W	PE14 Mode
9	PE14MD1	0	R/W	Select the function of the PE14/TIOC4C pin.
8	PE14MD0	0	R/W	000: PE14 I/O (port) 001: TIOC4C I/O (MTU2) Other than above: Setting prohibited
7, 6	—	All 0	R	Reserved These bits are always read as 0. The write value should always be 0.
5	PE13MD1	0	R/W	PE13 Mode
4	PE13MD0	0	R/W	Select the function of the PE13/TIOC4B/ $\overline{\text{MRES}}$ pin. 00: PE13 I/O (port) 01: TIOC4B I/O (MTU2) 10: $\overline{\text{MRES}}$ input (INTC) Other than above: Setting prohibited
3	—	0	R	Reserved This bit is always read as 0. The write value should always be 0.
2	PE12MD2	0	R/W	PE12 Mode
1	PE12MD1	0	R/W	Select the function of the PE12/TIOC4A pin.
0	PE12MD0	0	R/W	000: PE12 I/O (port) 001: TIOC4A I/O (MTU2) Other than above: Setting prohibited

- Port E Control Register L3 (PECRL3)

Bit:	15	14	13	12	11	10	9	8	7	6	5	4	3	2	1	0
	-	PE11 MD2	PE11 MD1	PE11 MD0	-	PE10 MD2	PE10 MD1	PE10 MD0	-	PE9 MD2	PE9 MD1	PE9 MD0	-	PE8 MD2	PE8 MD1	PE8 MD0
Initial value:	0	0	0	0	0	0*	0	0	0	0	0	0	0	0*	0	0
R/W:	R	R/W	R/W	R/W	R	R/W	R/W	R/W	R	R/W	R/W	R/W	R	R/W	R/W	R/W

Note: * The initial value is 1 in the on-chip ROM disabled external-extension mode.

Bit	Bit Name	Initial Value	R/W	Description
15	—	0	R	Reserved This bit is always read as 0. The write value should always be 0.
14	PE11MD2	0	R/W	PE11 Mode
13	PE11MD1	0	R/W	Select the function of the PE11/TIOC3D pin.
12	PE11MD0	0	R/W	000: PE11 I/O (port) 001: TIOC3D I/O (MTU2) Other than above: Setting prohibited
11	—	0	R	Reserved This bit is always read as 0. The write value should always be 0.
10	PE10MD2	0* ¹	R/W	PE10 Mode
9	PE10MD1	0	R/W	Select the function of the PE10/ $\overline{CS0}$ /TIOC3C pin.
8	PE10MD0	0	R/W	000: PE10 I/O (port) 001: TIOC3C I/O (MTU2) 100: $\overline{CS0}$ output (BSC)* ² Other than above: Setting prohibited
7	—	0	R	Reserved This bit is always read as 0. The write value should always be 0.
6	PE9MD2	0	R/W	PE9 Mode
5	PE9MD1	0	R/W	Select the function of the PE9/TIOC3B pin.
4	PE9MD0	0	R/W	000: PE9 I/O (port) 001: TIOC3B I/O (MTU2) Other than above: Setting prohibited

Bit	Bit Name	Initial Value	R/W	Description
3	—	0	R	Reserved This bit is always read as 0. The write value should always be 0.
2	PE8MD2	0* ¹	R/W	PE8 Mode
1	PE8MD1	0	R/W	Select the function of the PE8/A15/TIOC3A pin.
0	PE8MD0	0	R/W	000: PE8 I/O (port) 001: TIOC3A I/O (MTU2) 100: A15 output (BSC)* ² Other than above: Setting prohibited

- Notes: 1. The initial value is 1 in the on-chip ROM disabled external-extension mode.
2. This function is enabled only in the on-chip ROM enabled/disabled external-extension mode. Do not set 1 in single-chip mode.

- Port E Control Register L2 (PECRL2)

Bit:	15	14	13	12	11	10	9	8	7	6	5	4	3	2	1	0
	-	PE7 MD2	PE7 MD1	PE7 MD0	-	PE6 MD2	PE6 MD1	PE6 MD0	-	PE5 MD2	PE5 MD1	PE5 MD0	-	PE4 MD2	PE4 MD1	PE4 MD0
Initial value:	0	0*	0	0	0	0*	0	0	0	0*	0	0	0	0*	0	0
R/W:	R	R/W	R/W	R/W	R	R/W	R/W	R/W	R	R/W	R/W	R/W	R	R/W	R/W	R/W

Note: * The initial value is 1 in the on-chip ROM disabled external-extension mode.

Bit	Bit Name	Initial Value	R/W	Description
15	—	0	R	Reserved This bit is always read as 0. The write value should always be 0.
14	PE7MD2	0* ¹	R/W	PE7 Mode
13	PE7MD1	0	R/W	Select the function of the PE7/A14/TIOC2B pin.
12	PE7MD0	0	R/W	000: PE7 I/O (port) 001: TIOC2B I/O (MTU2) 100: A14 output (BSC)* ² Other than above: Setting prohibited
11	—	0	R	Reserved This bit is always read as 0. The write value should always be 0.

Bit	Bit Name	Initial Value	R/W	Description
10	PE6MD2	0* ¹	R/W	PE6 Mode
9	PE6MD1	0	R/W	Select the function of the PE6/A13/TIOC2A/SCK1 pin.
8	PE6MD0	0	R/W	000: PE6 I/O (port) 001: TIOC2A I/O (MTU2) 100: A13 output (BSC)* ² 110: SCK1 I/O (SCI) Other than above: Setting prohibited
7	—	0	R	Reserved This bit is always read as 0. The write value should always be 0.
6	PE5MD2	0* ¹	R/W	PE5 Mode
5	PE5MD1	0	R/W	Select the function of the PE5/A12/TIOC1B/TXD1 pin.
4	PE5MD0	0	R/W	000: PE5 I/O (port) 001: TIOC1B I/O (MTU2) 100: A12 output (BSC)* ² 110: TXD1 output (SCI) Other than above: Setting prohibited
3	—	0	R	Reserved This bit is always read as 0. The write value should always be 0.
2	PE4MD2	0* ¹	R/W	PE4 Mode
1	PE4MD1	0	R/W	Select the function of the PE4/A11/TIOC1A/RXD1 pin.
0	PE4MD0	0	R/W	000: PE4 I/O (port) 001: TIOC1A I/O (MTU2) 100: A11 output (BSC)* ² 110: RXD1 input (SCI) Other than above: Setting prohibited

- Notes: 1. The initial value is 1 in the on-chip ROM disabled external-extension mode.
2. This function is enabled only in the on-chip ROM enabled/disabled external-extension mode. Do not set 1 in single-chip mode.

- Port E Control Register L1 (PECRL1)

Bit:	15	14	13	12	11	10	9	8	7	6	5	4	3	2	1	0
	-	PE3 MD2	PE3 MD1	PE3 MD0	-	PE2 MD2	PE2 MD1	PE2 MD0	-	PE1 MD2	PE1 MD1	PE1 MD0	-	-	PE0 MD1	PE0 MD0
Initial value:	0	0	0	0	0	0	0	0	0	0	0	0	0	0	0	0
R/W:	R	R/W	R/W	R/W	R	R/W	R/W	R/W	R	R/W	R/W	R/W	R	R	R/W	R/W

Bit	Bit Name	Initial Value	R/W	Description
15	—	0	R	Reserved This bit is always read as 0. The write value should always be 0.
14	PE3MD2	0	R/W	PE3 Mode
13	PE3MD1	0	R/W	Select the function of the PE3/TIOC0D/SCK0 pin.
12	PE3MD0	0	R/W	000: PE3 I/O (port) 001: TIOC0D I/O (MTU2) 110: SCK0 I/O (SCI) Other than above: Setting prohibited
11	—	0	R	Reserved This bit is always read as 0. The write value should always be 0.
10	PE2MD2	0	R/W	PE2 Mode
9	PE2MD1	0	R/W	Select the function of the PE2/TIOC0C/TXD0 pin.
8	PE2MD0	0	R/W	000: PE2 I/O (port) 001: TIOC0C I/O (MTU2) 110: TXD0 output (SCI) Other than above: Setting prohibited
7	—	0	R	Reserved This bit is always read as 0. The write value should always be 0.

Bit	Bit Name	Initial Value	R/W	Description
6	PE1MD2	0	R/W	PE1 Mode
5	PE1MD1	0	R/W	Select the function of the PE1/TIOC0B/RXD0 pin.
4	PE1MD0	0	R/W	000: PE1 I/O (port) 001: TIOC0B I/O (MTU2) 110: RXD0 input (SCI) Other than above: Setting prohibited
3, 2	—	All 0	R	Reserved These bits are always read as 0. The write value should always be 0.
1	PE0MD1	0	R/W	PE0 Mode
0	PE0MD0	0	R/W	Select the function of the PE0/TIOC0A pin. 00: PE0 I/O (port) 01: TIOC0A I/O (MTU2) Other than above: Setting prohibited

17.1.9 IRQOUT Function Control Register (IFCR)

IFCR is a 16-bit readable/writable register that is used to control the IRQOUT pin output when it is selected as the multiplexed pin function by port E control register L4 (PECRL4). When PECRL4 selects another function, the IFCR setting does not affect the pin function.

Bit:	15	14	13	12	11	10	9	8	7	6	5	4	3	2	1	0
	-	-	-	-	-	-	-	-	-	-	-	-	-	-	IRQ MD1	IRQ MD0
Initial value:	0	0	0	0	0	0	0	0	0	0	0	0	0	0	0	0
R/W:	R	R	R	R	R	R	R	R	R	R	R	R	R	R	R/W	R/W

Bit	Bit Name	Initial Value	R/W	Description
15 to 2	—	All 0	R	Reserved These bits are always read as 0. The write value should always be 0.
1	IRQMD1	0	R/W	Port E $\overline{\text{IRQOUT}}$ Pin Function Select
0	IRQMD0	0	R/W	Select the $\overline{\text{IRQOUT}}$ pin function when bits 14 to 12 (PE15MD2 to PE15MD0) in PECRL4 are set to B'011. 00: Interrupt request accept signal output 01: Setting prohibited 10: Interrupt request accept signal output 11: Always high-level output

17.2 Usage Notes

1. In this LSI, the same function is available as a multiplexed function on multiple pins. This approach is intended to increase the number of selectable pin functions and to allow the easier design of boards. If two or more pins are specified for one function, however, there are two cautions shown below.

— When the pin function is input

Signals input to several pins are formed as one signal through OR or AND logic and the signal is transmitted into the LSI. Therefore, a signal that differs from the input signals may be transmitted to the LSI depending on the input signals in other pins that have the same functions. Table 17.13 shows the transmit forms of input functions allocated to several pins. When using one of the functions shown below in multiple pins, use it with care of signal polarity considering the transmit forms.

Table 17.13 Transmit Forms of Input Functions Allocated to Multiple Pins

OR Type	AND Type
SCK0 to SCK2, RXD0 to RXD2	IRQ0 to IRQ3, $\overline{\text{WAIT}}$, $\overline{\text{POE0}}$, $\overline{\text{POE1}}$, $\overline{\text{POE4}}$ to $\overline{\text{POE5}}$, $\overline{\text{POE8}}$

OR type: Signals input to several pins are formed as one signal through OR logic and the signal is transmitted into the LSI.

AND type: Signals input to several pins are formed as one signal through AND logic and the signal is transmitted into the LSI.

— When the pin function is output

Each selected pin can output the same function.

2. When the port input is switched from a low level to the IRQ edge for the pins that are multiplexed with input/output and IRQ, the corresponding edge is detected.
3. Do not set functions other than those specified in tables 17.9 to 17.11. Otherwise, correct operation cannot be guaranteed.
4. PFC setting in single-chip mode (MCU operating mode 3)

In single-chip mode, do not set the PFC to select address bus, data bus, bus control, or the $\overline{\text{BREQ}}$, $\overline{\text{BACK}}$, or CK signals. If they are selected, address bus signals function as high- or low-level outputs, data bus signals function as high-impedance outputs, and the other output signals function as high-level outputs. As $\overline{\text{BREQ}}$ and $\overline{\text{WAIT}}$ function as inputs, do not leave them open. However, the bus-mastership-request inputs and external waits are disabled.

Section 18 I/O Ports

The SH7146 has four ports: A, B, E, and F. Port A is a 16-bit port, port B is a 7-bit port, and port E is a 22-bit port. Port F is a 12-bit input-only port.

The SH7149 has five ports: A, B, D, E, and F. Port A is a 16-bit port, port B is a 9-bit port, port D is a 16-bit port, and port E is a 22-bit port. Port F is a 12-bit input-only port.

All the port pins are multiplexed as general input/output pins and special function pins. The functions of the multiplex pins are selected by means of the pin function controller (PFC). Each port is provided with a data register for storing the pin data.

18.1 Port A

Port A in the SH7146 is an input/output port with the 16 pins shown in figure 18.1.

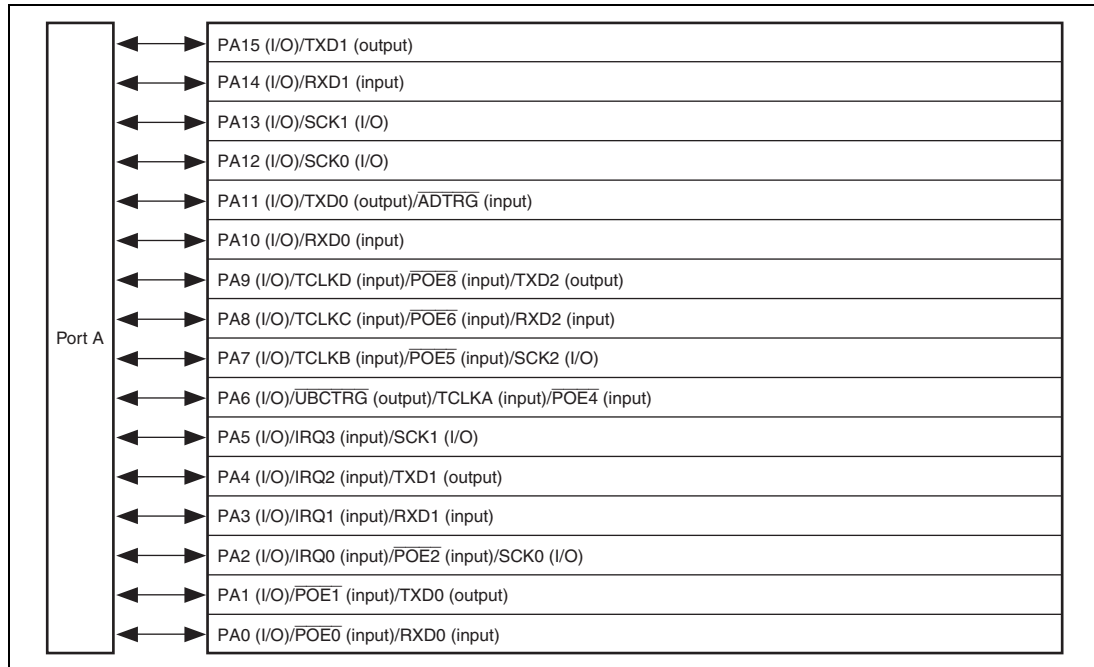

Figure 18.1 Port A (SH7146)

Port A in the SH7149 is an input/output port with the 16 pins shown in figure 18.2.

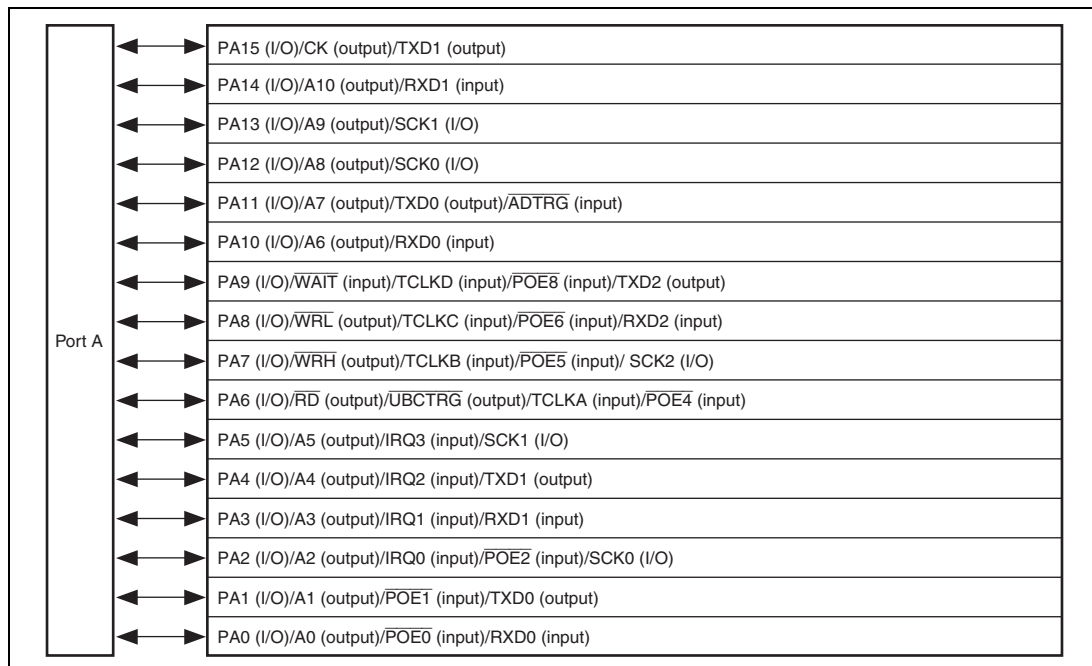

Figure 18.2 Port A (SH7149)

18.1.1 Register Descriptions

Port A is a 16-bit input/output port. Port A has the following registers. For details on register addresses and register states during each processing, refer to section 23, List of Registers.

Table 18.1 Register Configuration

Register Name	Abbreviation	R/W	Initial Value	Address	Access Size
Port A data register L	PADRL	R/W	H'0000	H'FFFD102	8, 16
Port A port register L	PAPRL	R	H'xxxx	H'FFFD11E	8, 16

18.1.2 Port A Data Register L (PADRL)

The port A data register L (PADRL) is a 16-bit readable/writable register that stores port A data. Bits PA15DR to PA0DR correspond to pins PA15 to PA0 (multiplexed functions omitted here).

When a pin function is general output, if a value is written to PADRL, that value is output directly from the pin, and if PADRL is read, the register value is returned directly regardless of the pin state.

When a pin function is general input, if PADRL is read, the pin state, not the register value, is returned directly. If a value is written to PADRL, although that value is written into PADRL, it does not affect the pin state. Table 18.2 summarizes port A data register read/write operations.

Bit:	15	14	13	12	11	10	9	8	7	6	5	4	3	2	1	0
	PA15 DR	PA14 DR	PA13 DR	PA12 DR	PA11 DR	PA10 DR	PA9 DR	PA8 DR	PA7 DR	PA6 DR	PA5 DR	PA4 DR	PA3 DR	PA2 DR	PA1 DR	PA0 DR
Initial value:	0	0	0	0	0	0	0	0	0	0	0	0	0	0	0	0
R/W:	R/W	R/W	R/W	R/W	R/W	R/W	R/W	R/W	R/W	R/W	R/W	R/W	R/W	R/W	R/W	R/W

Bit	Bit Name	Initial Value	R/W	Description
15	PA15DR	0	R/W	See table 18.2.
14	PA14DR	0	R/W	
13	PA13DR	0	R/W	
12	PA12DR	0	R/W	
11	PA11DR	0	R/W	
10	PA10DR	0	R/W	
9	PA9DR	0	R/W	
8	PA8DR	0	R/W	
7	PA7DR	0	R/W	
6	PA6DR	0	R/W	
5	PA5DR	0	R/W	
4	PA4DR	0	R/W	
3	PA3DR	0	R/W	
2	PA2DR	0	R/W	
1	PA1DR	0	R/W	
0	PA0DR	0	R/W	

Table 18.2 Port A Data Register L (PADRL) Read/Write Operations

- PADRL Bits 15 to 0

PAIOR	Pin Function	Read	Write
0	General input	Pin state	Can write to PADRL, but it has no effect on pin state
	Other than general input	Pin state	Can write to PADRL, but it has no effect on pin state
1	General output	PADRL value	Value written is output from pin
	Other than general output	PADRL value	Can write to PADRL, but it has no effect on pin state

18.1.3 Port A Port Register L (PAPRL)

The port A port register L (PAPRL) is a 16-bit read-only register that always returns the states of the pins regardless of the PFC setting. Bits PA15PR to PA0PR correspond to pins PA15 to PA0 (multiplexed functions omitted here).

Bit:	15	14	13	12	11	10	9	8	7	6	5	4	3	2	1	0
	PA15 PR	PA14 PR	PA13 PR	PA12 PR	PA11 PR	PA10 PR	PA9 PR	PA8 PR	PA7 PR	PA6 PR	PA5 PR	PA4 PR	PA3 PR	PA2 PR	PA1 PR	PA0 PR
Initial value:	*	*	*	*	*	*	*	*	*	*	*	*	*	*	*	*
R/W:	R	R	R	R	R	R	R	R	R	R	R	R	R	R	R	R

Bit	Bit Name	Initial Value	R/W	Description
15	PA15PR	Pin state	R	The pin state is returned regardless of the PFC setting. These bits cannot be modified.
14	PA14PR	Pin state	R	
13	PA13PR	Pin state	R	
12	PA12PR	Pin state	R	
11	PA11PR	Pin state	R	
10	PA10PR	Pin state	R	
9	PA9PR	Pin state	R	
8	PA8PR	Pin state	R	
7	PA7PR	Pin state	R	
6	PA6PR	Pin state	R	
5	PA5PR	Pin state	R	
4	PA4PR	Pin state	R	
3	PA3PR	Pin state	R	
2	PA2PR	Pin state	R	
1	PA1PR	Pin state	R	
0	PA0PR	Pin state	R	

18.2 Port B

Port B in the SH7146 is an input/output port with the seven pins shown in figure 18.3.

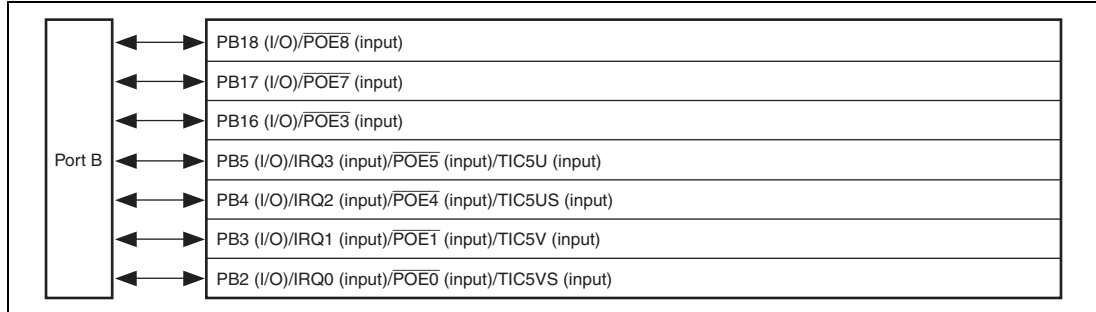

Figure 18.3 Port B (SH7146)

Port B in the SH7149 is an input/output port with the nine pins shown in figure 18.4.

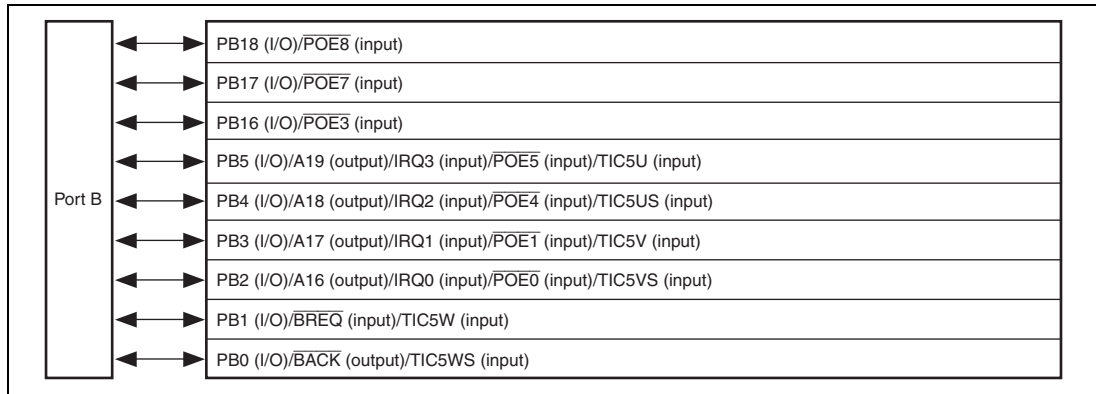

Figure 18.4 Port B (SH7149)

18.2.1 Register Descriptions

Port B is a 7-bit input/output port in the SH7146, a 9-bit input/output port in the SH7149. Port B has the following register. For details on register addresses and register states during each processing, refer to section 23, List of Registers.

Table 18.3 Register Configuration

Register Name	Abbreviation	R/W	Initial Value	Address	Access Size
Port B data register H	PBDRH	R/W	H'0000	H'FFFFD180	8, 16, 32
Port B data register L	PBDRL	R/W	H'0000	H'FFFFD182	8, 16
Port B port register H	PBPRH	R	H'000x	H'FFFFD19C	8, 16, 32
Port B port register L	PBPRL	R	H'00xx	H'FFFFD19E	8, 16

18.2.2 Port B Data Registers H and L (PBDRH and PBDRL)

The port B data registers H and L (PBDRH and PBDRL) are 16-bit readable/writable registers that store port B data. Bits PB18DR to PB16DR and PB5DR to PB2DR correspond to pins PB18 to PB16 and PB5 to PB2, respectively (multiplexed functions omitted here) in the SH7146. Bits PB18DR to PB16DR and PB5DR to PB0DR correspond to pins PB18 to PB16 and PB5 to PB0, respectively (multiplexed functions omitted here) in the SH7149.

When a pin function is general output, if a value is written to PBDRH or PBDRL, that value is output directly from the pin, and if PBDRH or PBDRL is read, the register value is returned directly regardless of the pin state.

When a pin function is general input, if PBDRH or PBDRL is read, the pin state, not the register value, is returned directly. If a value is written to PBDRH or PBDRL, although that value is written into PBDRH or PBDRL, it does not affect the pin state. Table 18.4 summarizes port B data register read/write operations.

- **PBDRH**

Bit:	15	14	13	12	11	10	9	8	7	6	5	4	3	2	1	0
	-	-	-	-	-	-	-	-	-	-	-	-	-	PB18 DR	PB17 DR	PB16 DR
Initial value:	0	0	0	0	0	0	0	0	0	0	0	0	0	0	0	0
R/W:	R	R	R	R	R	R	R	R	R	R	R	R	R	R/W	R/W	R/W

Bit	Bit Name	Initial Value	R/W	Description
15 to 3	—	All 0	R	Reserved These bits are always read as 0. The write value should always be 0.
2	PB18DR	0	R/W	See table 18.4.
1	PB17DR	0	R/W	
0	PB16DR	0	R/W	

- **PBDRL (SH7146)**

Bit:	15	14	13	12	11	10	9	8	7	6	5	4	3	2	1	0
	-	-	-	-	-	-	-	-	-	-	PB5 DR	PB4 DR	PB3 DR	PB2 DR	-	-
Initial value:	0	0	0	0	0	0	0	0	0	0	0	0	0	0	0	0
R/W:	R	R	R	R	R	R	R	R	R	R	R/W	R/W	R/W	R/W	R	R

Bit	Bit Name	Initial Value	R/W	Description
15 to 6	—	All 0	R	Reserved These bits are always read as 0. The write value should always be 0.
5	PB5DR	0	R/W	See table 18.4.
4	PB4DR	0	R/W	
3	PB3DR	0	R/W	
2	PB2DR	0	R/W	
1, 0	—	All 0	R	Reserved These bits are always read as 0. The write value should always be 0.

- PBDRL (SH7149)

Bit:	15	14	13	12	11	10	9	8	7	6	5	4	3	2	1	0
	-	-	-	-	-	-	-	-	-	-	PB5DR	PB4DR	PB3DR	PB2DR	PB1DR	PB0DR
Initial value:	0	0	0	0	0	0	0	0	0	0	0	0	0	0	0	0
R/W:	R	R	R	R	R	R	R	R	R	R	R/W	R/W	R/W	R/W	R/W	R/W

Bit	Bit Name	Initial Value	R/W	Description
15 to 6	—	All 0	R	Reserved These bits are always read as 0. The write value should always be 0.
5	PB5DR	0	R/W	See table 18.4.
4	PB4DR	0	R/W	
3	PB3DR	0	R/W	
2	PB2DR	0	R/W	
1	PB1DR	0	R/W	
0	PB0DR	0	R/W	

Table 18.4 Port B Data Register (PBDR) Read/Write Operations

- PBDRH Bits 2 to 0 and PBDRL Bits 9 to 0

PBIOR	Pin Function	Read	Write
0	General input	Pin state	Can write to PBDRH and PBDRL, but it has no effect on pin state
	Other than general input	Pin state	Can write to PBDRH and PBDRL, but it has no effect on pin state
1	General output	PBDRH or PBDRL value	Value written is output from pin
	Other than general output	PBDRH or PBDRL value	Can write to PBDRH and PBDRL, but it has no effect on pin state

18.2.3 Port B Port Registers H and L (PBPRH and PBPRL)

The port B port registers H and L (PBPRH and PBPRL) are 16-bit read-only registers that always return the states of the pins regardless of the PFC setting. Bits PB18PR to PB16PR and PB5PR to PB2PR correspond to pins PB18 to PB16 and PB5 to PB2, respectively (multiplexed functions omitted here) in the SH7146. Bits PB18PR to PB16PR and PB5PR to PB0PR correspond to pins PB18 to PB16 and PB5 to PB0, respectively (multiplexed functions omitted here) in the SH7149.

- PBPRH

Bit:	15	14	13	12	11	10	9	8	7	6	5	4	3	2	1	0
	-	-	-	-	-	-	-	-	-	-	-	-	-	PB18 PR	PB17 PR	PB16 PR
Initial value:	0	0	0	0	0	0	0	0	0	0	0	0	0	*	*	*
R/W:	R	R	R	R	R	R	R	R	R	R	R	R	R	R	R	R

Bit	Bit Name	Initial Value	R/W	Description
15 to 3	—	All 0	R	Reserved These bits are always read as 0. The write value should always be 0.
2	PB18PR	Pin state	R	The pin state is returned regardless of the PFC setting. These bits cannot be modified.
1	PB17PR	Pin state	R	
0	PB16PR	Pin state	R	

- PBPRL (SH7146)

Bit:	15	14	13	12	11	10	9	8	7	6	5	4	3	2	1	0
	-	-	-	-	-	-	-	-	-	-	PB5 PR	PB4 PR	PB3 PR	PB2 PR	-	-
Initial value:	0	0	0	0	0	0	0	0	0	0	*	*	*	*	0	0
R/W:	R	R	R	R	R	R	R	R	R	R	R	R	R	R	R	R

Bit	Bit Name	Initial Value	R/W	Description
15 to 6	—	All 0	R	Reserved These bits are always read as 0. The write value should always be 0.
5	PB5PR	Pin state	R	The pin state is returned regardless of the PFC setting. These bits cannot be modified.
4	PB4PR	Pin state	R	
3	PB3PR	Pin state	R	
2	PB2PR	Pin state	R	
1, 0	—	All 0	R	Reserved These bits are always read as 0. The write value should always be 0.

- PBPRL (SH7149)

Bit:	15	14	13	12	11	10	9	8	7	6	5	4	3	2	1	0
	-	-	-	-	-	-	-	-	-	-	PB5 PR	PB4 PR	PB3 PR	PB2 PR	PB1 PR	PB0 PR
Initial value:	0	0	0	0	0	0	0	0	0	0	*	*	*	*	*	*
R/W:	R	R	R	R	R	R	R	R	R	R	R	R	R	R	R	R

Bit	Bit Name	Initial Value	R/W	Description
15 to 6	—	All 0	R	Reserved These bits are always read as 0. The write value should always be 0.
5	PB5PR	Pin state	R	The pin state is returned regardless of the PFC setting. These bits cannot be modified.
4	PB4PR	Pin state	R	
3	PB3PR	Pin state	R	
2	PB2PR	Pin state	R	
1	PB1PR	Pin state	R	
0	PB0PR	Pin state	R	

18.3 Port D (SH7149 Only)

Port D in the SH7149 is an input/output port with the 16 pins shown in figure 18.5.

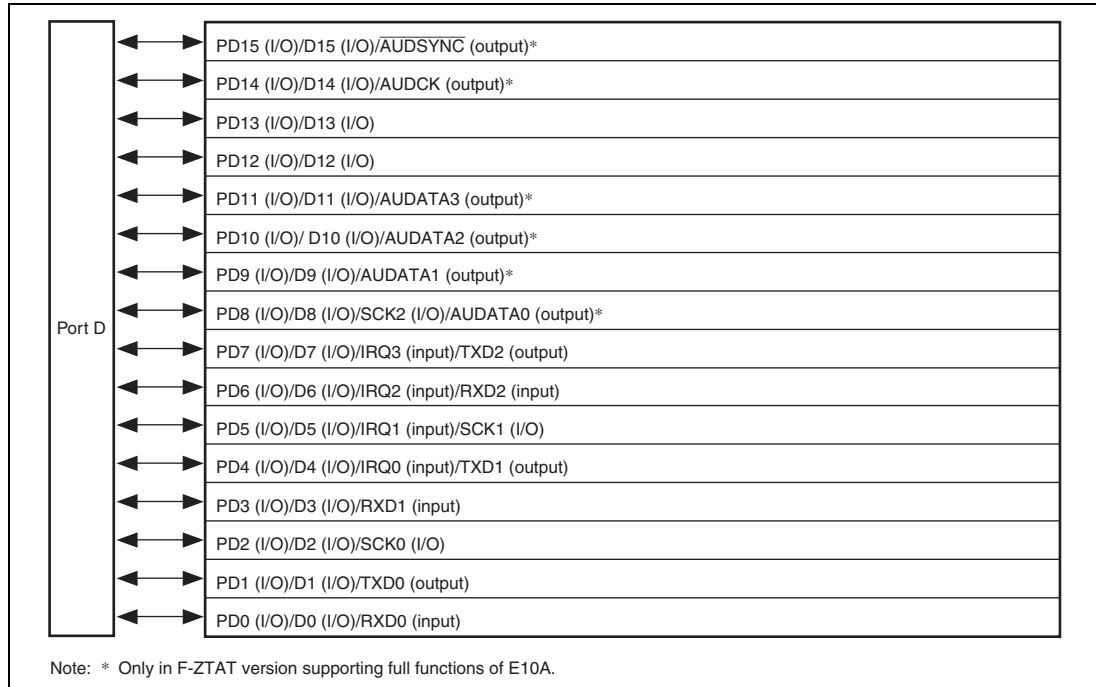

Figure 18.5 Port D

18.3.1 Register Descriptions

Port D is a 16-bit input/output port. Note that port D is not available in the SH7146. Port D has the following registers. For details on register addresses and register states during each processing, refer to section 23, List of Registers.

Table 18.5 Register Configuration

Register Name	Abbreviation	R/W	Initial Value	Address	Access Size
Port D data register L	PDDRL	R/W	H'0000	H'FFFFD282	8, 16
Port D port register L	PDPRL	R	H'xxxx	H'FFFFD29E	8, 16

18.3.2 Port D Data Register L (PDDRL)

The port D data register L (PDDRL) is a 16-bit readable/writable register that stores port D data. Bits PD15DR to PD0DR correspond to pins PD15 to PD0 (multiplexed functions omitted here).

When a pin function is general output, if a value is written to PDDRL, that value is output directly from the pin, and if PDDRL is read, the register value is returned directly regardless of the pin state.

When a pin function is general input, if PDDRL is read, the pin state, not the register value, is returned directly. If a value is written to PDDRL, although that value is written into PDDRL, it does not affect the pin state. Table 18.6 summarizes port D data register read/write operations.

Bit:	15	14	13	12	11	10	9	8	7	6	5	4	3	2	1	0
	PD15 DR	PD14 DR	PD13 DR	PD12 DR	PD11 DR	PD10 DR	PD9 DR	PD8 DR	PD7 DR	PD6 DR	PD5 DR	PD4 DR	PD3 DR	PD2 DR	PD1 DR	PD0 DR
Initial value:	0	0	0	0	0	0	0	0	0	0	0	0	0	0	0	0
R/W:	R/W	R/W	R/W	R/W	R/W	R/W	R/W	R/W	R/W	R/W	R/W	R/W	R/W	R/W	R/W	R/W

Bit	Bit Name	Initial Value	R/W	Description
15	PD15DR	0	R/W	See table 18.6.
14	PD14DR	0	R/W	
13	PD13DR	0	R/W	
12	PD12DR	0	R/W	
11	PD11DR	0	R/W	
10	PD10DR	0	R/W	
9	PD9DR	0	R/W	
8	PD8DR	0	R/W	
7	PD7DR	0	R/W	
6	PD6DR	0	R/W	
5	PD5DR	0	R/W	
4	PD4DR	0	R/W	
3	PD3DR	0	R/W	
2	PD2DR	0	R/W	
1	PD1DR	0	R/W	
0	PD0DR	0	R/W	

Table 18.6 Port D Data Register L (PDDRL) Read/Write Operations

- PDDRL Bits 15 to 0

PDIOR	Pin Function	Read	Write
0	General input	Pin state	Can write to PDDRL, but it has no effect on pin state
	Other than general input	Pin state	Can write to PDDRL, but it has no effect on pin state
1	General output	PDDRL value	Value written is output from pin
	Other than general output	PDDRL value	Can write to PDDRL, but it has no effect on pin state

18.3.3 Port D Port Register L (PDPRL)

The port D port register L (PDPRL) is a 16-bit read-only register that always returns the states of the pins regardless of the PFC setting. Bits PD15PR to PD0PR correspond to pins PD15 to PD0 (multiplexed functions omitted here).

Bit:	15	14	13	12	11	10	9	8	7	6	5	4	3	2	1	0
	PD15 PR	PD14 PR	PD13 PR	PD12 PR	PD11 PR	PD10 PR	PD9 PR	PD8 PR	PD7 PR	PD6 PR	PD5 PR	PD4 PR	PD3 PR	PD2 PR	PD1 PR	PD0 PR
Initial value:	*	*	*	*	*	*	*	*	*	*	*	*	*	*	*	*
R/W:	R	R	R	R	R	R	R	R	R	R	R	R	R	R	R	R

Bit	Bit Name	Initial Value	R/W	Description
15	PD15PR	Pin state	R	The pin state is returned regardless of the PFC setting. These bits cannot be modified.
14	PD14PR	Pin state	R	
13	PD13PR	Pin state	R	
12	PD12PR	Pin state	R	
11	PD11PR	Pin state	R	
10	PD10PR	Pin state	R	
9	PD9PR	Pin state	R	
8	PD8PR	Pin state	R	
7	PD7PR	Pin state	R	
6	PD6PR	Pin state	R	
5	PD5PR	Pin state	R	
4	PD4PR	Pin state	R	
3	PD3PR	Pin state	R	
2	PD2PR	Pin state	R	
1	PD1PR	Pin state	R	
0	PD0PR	Pin state	R	

18.4 Port E

Port E in the SH7146 is an input/output port with the 22 pins shown in figure 18.6.

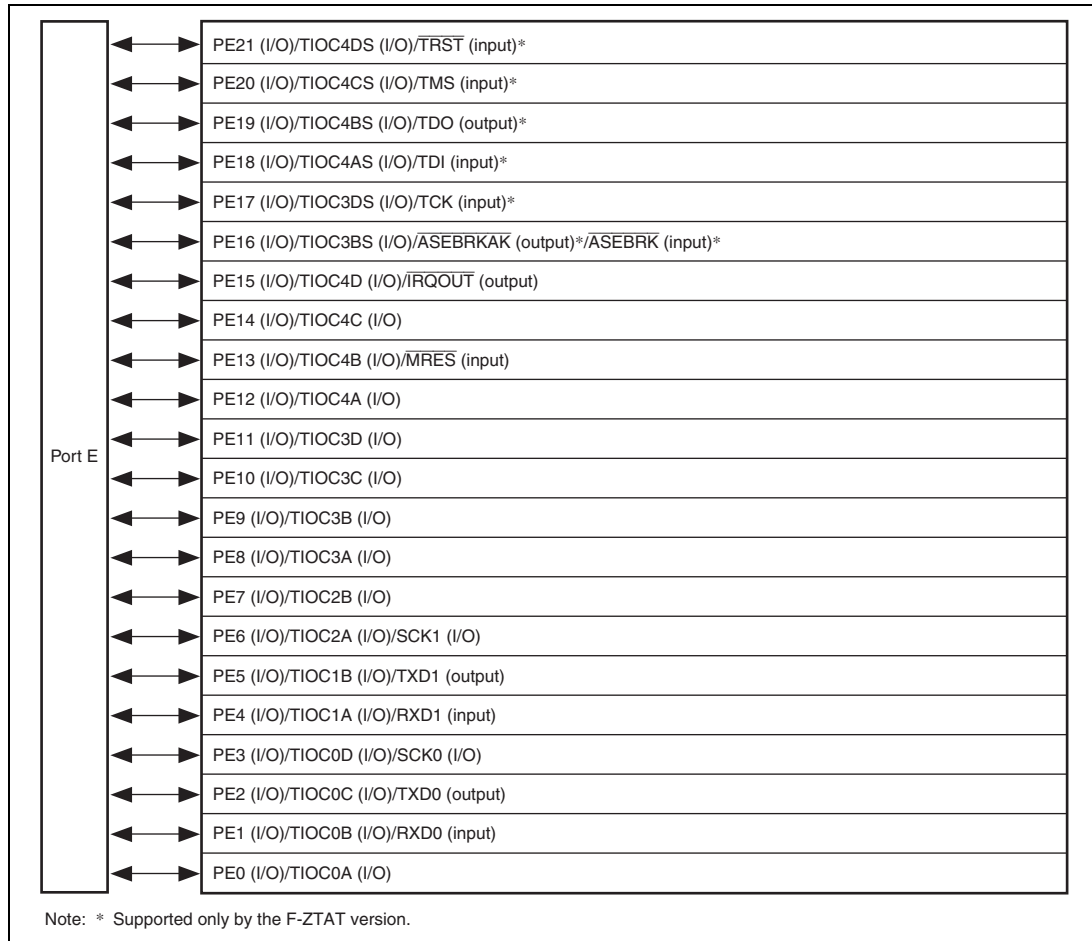

Figure 18.6 Port E (SH7146)

Port E in the SH7149 is an input/output port with the 22 pins shown in figure 18.7.

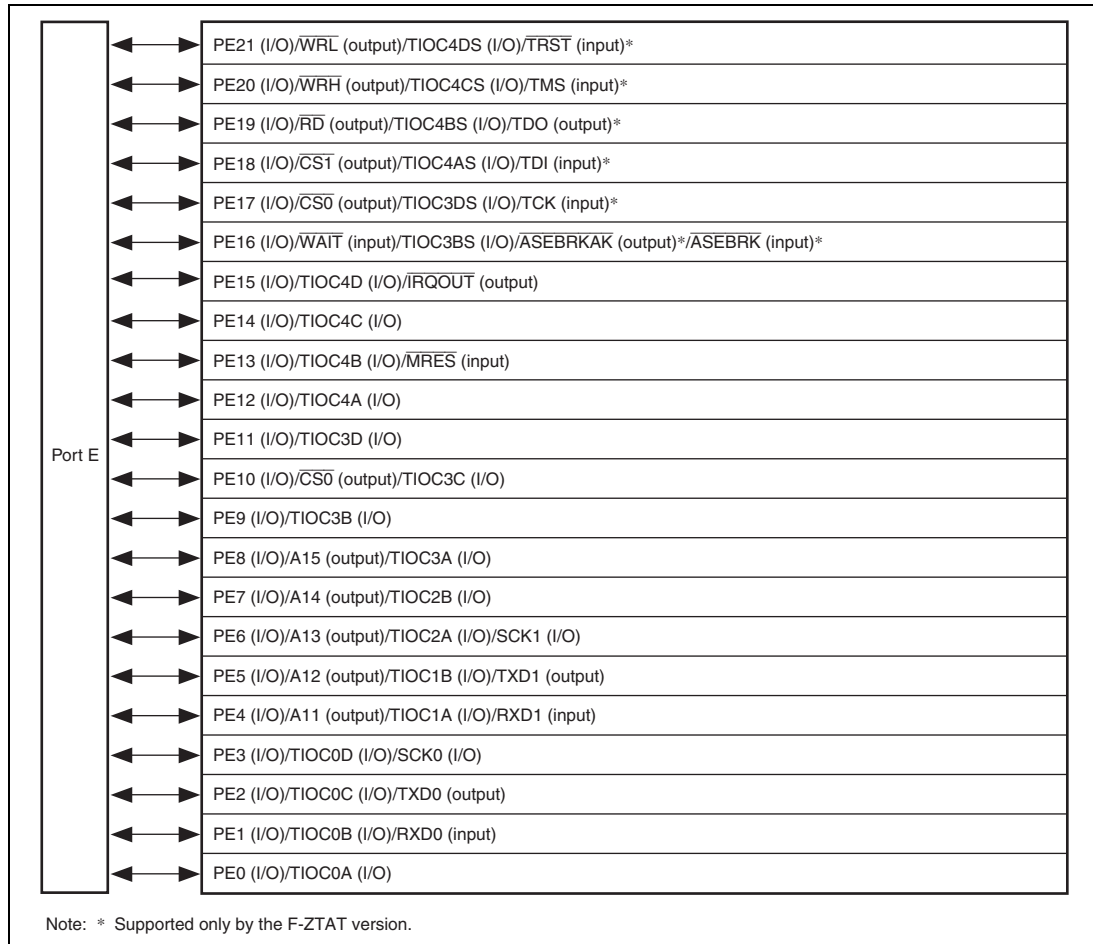

Figure 18.7 Port E (SH7149)

18.4.1 Register Descriptions

Port E is a 22-bit input/output port. Port E has the following registers. For details on register addresses and register states during each processing, refer to section 23, List of Registers.

Table 18.7 Register Configuration

Register Name	Abbrevia- tion	R/W	Initial Value	Address	Access Size
Port E data register H	PEDRH	R/W	H'0000	H'FFFFD300	8, 16, 32
Port E data register L	PEDRL	R/W	H'0000	H'FFFFD302	8, 16
Port E port register H	PEPRH	R	H'00xx	H'FFFFD31C	8, 16, 32
Port E port register L	PEPRL	R	H'00xx	H'FFFFD31E	8, 16

18.4.2 Port E Data Registers H and L (PEDRH and PEDRL)

The port E data registers H and L (PEDRH and PEDRL) are 16-bit readable/writable registers that store port E data. Bits PE21DR to PE0DR correspond to pins PE21 to PE0, respectively (multiplexed functions omitted here).

When a pin function is general output, if a value is written to PEDRH or PEDRL, that value is output directly from the pin, and if PEDRH or PEDRL is read, the register value is returned directly regardless of the pin state.

When a pin function is general input, if PEDRH or PEDRL is read, the pin state, not the register value, is returned directly. If a value is written to PEDRH or PEDRL, although that value is written into PEDRH or PEDRL, it does not affect the pin state. Table 18.8 summarizes port E data register read/write operations.

- PEDRH

Bit:	15	14	13	12	11	10	9	8	7	6	5	4	3	2	1	0
	-	-	-	-	-	-	-	-	-	-	PE21DR	PE20DR	PE19DR	PE18DR	PE17DR	PE16DR
Initial value:	0	0	0	0	0	0	0	0	0	0	0	0	0	0	0	0
R/W:	R	R	R	R	R	R	R	R	R	R	R/W	R/W	R/W	R/W	R/W	R/W

Bit	Bit Name	Initial Value	R/W	Description
15 to 6	—	All 0	R	Reserved These bits are always read as 0. The write value should always be 0.
5	PE21DR	0	R/W	See table 18.8.
4	PE20DR	0	R/W	
3	PE19DR	0	R/W	
2	PE18DR	0	R/W	
1	PE17DR	0	R/W	
0	PE16DR	0	R/W	

- PEDRL

Bit:	15	14	13	12	11	10	9	8	7	6	5	4	3	2	1	0
	PE15DR	PE14DR	PE13DR	PE12DR	PE11DR	PE10DR	PE9DR	PE8DR	PE7DR	PE6DR	PE5DR	PE4DR	PE3DR	PE2DR	PE1DR	PE0DR
Initial value:	0	0	0	0	0	0	0	0	0	0	0	0	0	0	0	0
R/W:	R/W	R/W	R/W	R/W	R/W	R/W	R/W	R/W	R/W	R/W	R/W	R/W	R/W	R/W	R/W	R/W

Bit	Bit Name	Initial Value	R/W	Description
15	PE15DR	0	R/W	See table 18.8.
14	PE14DR	0	R/W	
13	PE13DR	0	R/W	
12	PE12DR	0	R/W	
11	PE11DR	0	R/W	
10	PE10DR	0	R/W	
9	PE9DR	0	R/W	
8	PE8DR	0	R/W	
7	PE7DR	0	R/W	
6	PE6DR	0	R/W	
5	PE5DR	0	R/W	
4	PE4DR	0	R/W	
3	PE3DR	0	R/W	
2	PE2DR	0	R/W	
1	PE1DR	0	R/W	
0	PE0DR	0	R/W	

Table 18.8 Port E Data Register (PEDR) Read/Write Operations

- PEDRH Bits 5 to 0 and PEDRL Bits 15 to 0

PEIOR	Pin Function	Read	Write
0	General input	Pin state	Can write to PEDRH and PEDRL, but it has no effect on pin state
	Other than general input	Pin state	Can write to PEDRH and PEDRL, but it has no effect on pin state
1	General output	PEDRH or PEDRL value	Value written is output from pin
	Other than general output	PEDRH or PEDRL value	Can write to PEDRH and PEDRL, but it has no effect on pin state

18.4.3 Port E Port Registers H and L (PEPRH and PEPRL)

The port E port registers H and L (PEPRH and PEPRL) are 16-bit read-only registers that always return the states of the pins regardless of the PFC setting. Bits PE21PR to PE0PR correspond to pins PE21 to PE0, respectively (multiplexed functions omitted here).

- PEPRH

Bit:	15	14	13	12	11	10	9	8	7	6	5	4	3	2	1	0
	-	-	-	-	-	-	-	-	-	-	PE21 PR	PE20 PR	PE19 PR	PE18 PR	PE17 PR	PE16 PR
Initial value:	0	0	0	0	0	0	0	0	0	0	*	*	*	*	*	*
R/W:	R	R	R	R	R	R	R	R	R	R	R	R	R	R	R	R

Bit	Bit Name	Initial Value	R/W	Description
15 to 6	—	All 0	R	Reserved These bits are always read as 0. The write value should always be 0.
5	PE21PR	Pin state	R	The pin state is returned regardless of the PFC setting.
4	PE20PR	Pin state	R	These bits cannot be modified.
3	PE19PR	Pin state	R	
2	PE18PR	Pin state	R	
1	PE17PR	Pin state	R	
0	PE16PR	Pin state	R	

- PEPRL

Bit:	15	14	13	12	11	10	9	8	7	6	5	4	3	2	1	0
	PE15 PR	PE14 PR	PE13 PR	PE12 PR	PE11 PR	PE10 PR	PE9 PR	PE8 PR	PE7 PR	PE6 PR	PE5 PR	PE4 PR	PE3 PR	PE2 PR	PE1 PR	PE0 PR
Initial value:	*	*	*	*	*	*	*	*	*	*	*	*	*	*	*	*
R/W:	R	R	R	R	R	R	R	R	R	R	R	R	R	R	R	R

Bit	Bit Name	Initial Value	R/W	Description
15	PE15PR	Pin state	R	The pin state is returned regardless of the PFC setting. These bits cannot be modified.
14	PE14PR	Pin state	R	
13	PE13PR	Pin state	R	
12	PE12PR	Pin state	R	
11	PE11PR	Pin state	R	
10	PE10PR	Pin state	R	
9	PE9PR	Pin state	R	
8	PE8PR	Pin state	R	
7	PE7PR	Pin state	R	
6	PE6PR	Pin state	R	
5	PE5PR	Pin state	R	
4	PE4PR	Pin state	R	
3	PE3PR	Pin state	R	
2	PE2PR	Pin state	R	
1	PE1PR	Pin state	R	
0	PE0PR	Pin state	R	

18.5 Port F

Port F is an input-only port with the 12 pins shown in figure 18.8.

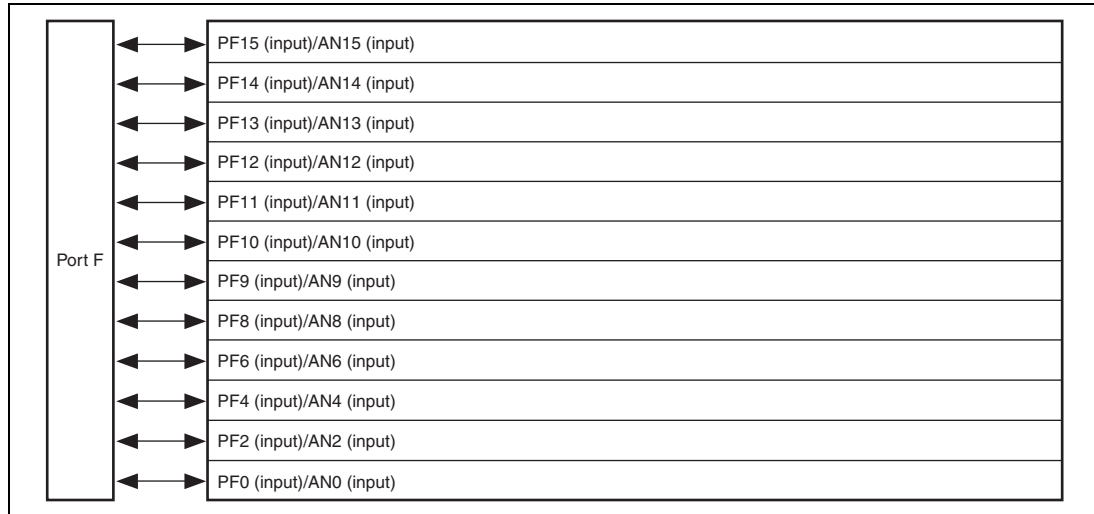

Figure 18.8 Port F

18.5.1 Register Descriptions

Port F is a 12-bit input-only port. Port F has the following register. For details on register addresses and register states during each processing, refer to section 23, List of Registers.

Table 18.9 Register Configuration

Register Name	Abbrevia- tion	R/W	Initial Value	Address	Access Size
Port F data register L	PFDR_L	R	H'xxxx	H'FFFFD382	8, 16

18.5.2 Port F Data Register L (PFDR_L)

The port F data register L (PFDR_L) is a 16-bit read-only register that stores port F data. Bits PF15DR to PF8DR, PF6DR, PF4DR, PF2DR, and PF0DR correspond to pins PF15 to PF8, PF6, PF4, PF2, and PF0, respectively (multiplexed functions omitted here).

Any value written into these bits is ignored, and there is no effect on the state of the pins. When any of the bits are read, the pin state rather than the bit value is read directly. However, when an A/D converter analog input is being sampled, values of 1 are read out. Table 18.10 summarizes port F data register L read/write operations.

Bit:	15	14	13	12	11	10	9	8	7	6	5	4	3	2	1	0
	PF15 DR	PF14 DR	PF13 DR	PF12 DR	PF11 DR	PF10 DR	PF9 DR	PF8 DR	-	PF6 DR	-	PF4 DR	-	PF2 DR	-	PF0 DR
Initial value:	*	*	*	*	*	*	*	*	0	*	0	*	0	*	0	*
R/W:	R	R	R	R	R	R	R	R	R	R	R	R	R	R	R	R

Bit	Bit Name	Initial Value	R/W	Description
15	PF15DR	Pin state	R	See table 18.10.
14	PF14DR	Pin state	R	
13	PF13DR	Pin state	R	
12	PF12DR	Pin state	R	
11	PF11DR	Pin state	R	
10	PF10DR	Pin state	R	
9	PF9DR	Pin state	R	
8	PF8DR	Pin state	R	
7	—	0	R	Reserved This bit is always read as 0. The write value should always be 0.
6	PF6DR	Pin state	R	See table 18.10.
5	—	0	R	Reserved This bit is always read as 0. The write value should always be 0.
4	PF4DR	Pin state	R	See table 18.10.
3	—	0	R	Reserved This bit is always read as 0. The write value should always be 0.
2	PF2DR	Pin state	R	See table 18.10.
1	—	0	R	Reserved This bit is always read as 0. The write value should always be 0.
0	PF0DR	Pin state	R	See table 18.10.

Table 18.10 Port F Data Register L (PFDR L) Read/Write Operations

- PFDR L Bits 15 to 0

Pin Function	Read	Write
General input	Pin state	Ignored (no effect on pin state)
ANn input (analog input)	1	Ignored (no effect on pin state)

Section 19 Flash Memory

This LSI has 256-kbyte on-chip flash memory. The flash memory has the following features.

19.1 Features

- Two flash-memory MATs, with one selected by the mode in which the LSI starts up
The on-chip flash memory has two memory spaces in the same address space (hereafter referred to as memory MATs). The mode setting when the LSI starts up determines the memory MAT that is currently mapped. The MAT can be switched by bank-switching after the LSI has started up.
 - Size of the user MAT, from which booting-up proceeds after a power-on reset in user mode: 256 kbytes
 - Size of the user boot MAT, from which booting-up proceeds after a power-on reset in user boot mode: 12 kbytes
- Three on-board programming modes and one off-board programming mode
 - On-board programming modes**
 - Boot Mode:** The on-chip SCI interface is used for programming in this mode. Either the user MAT or user-boot MAT can be programmed, and the bit rate for data transfer between the host and this LSI are automatically adjusted.
 - User Program Mode:** This mode allows programming of the user MAT via any desired interface.
 - User Boot Mode:** This mode allows writing of a user boot program via any desired interface and programming of the user MAT.
 - Off-board programming mode**
 - Programmer Mode:** This mode allows programming of the user MAT and user boot MAT with the aid of a PROM programmer.
- Downloading of an on-chip program to provide an interface for programming/erasure
This LSI has a dedicated programming/erasing program. After this program has been downloaded to the on-chip RAM, programming or erasing can be performed by setting parameters as arguments. “User branching” is also supported.

— User branching

Programming is performed in 128-byte units. Each round of programming consists of application of the programming pulse, reading for verification, and several other steps. Erasing is performed in block units and each round of erasing consists of several steps. A user-processing routine can be executed between each round of erasing, and making the setting for this is called the addition of a user branch.

- Using on-chip RAM to emulate flash memory

By laying on-chip RAM over part of the flash memory, flash-memory programming can be emulated in real time.

- Protection modes

There are two modes of protection: software protection is applied by register settings and hardware protection is applied by the level on the FWE pin. Protection of the flash memory from programming or erasure can be selected.

When an abnormal state is detected, such as runaway execution of programming/erasing, the protection modes initiate the transition to the error protection state and suspend programming/erasing processing.

- Programming/erasing time

The time taken to program 128 bytes of flash memory in a single round is t_p ms (typ.), which is equivalent to $t_p/128$ ms per byte. The erasing time is t_{eS} (typ.) per block.

- Number of programming operations

The flash memory can be programmed up to N_{wEC} times.

- Operating frequency for programming/erasing

The operating frequency for programming/erasing is a maximum of 40 MHz (Pφ).

19.2 Overview

19.2.1 Block Diagram

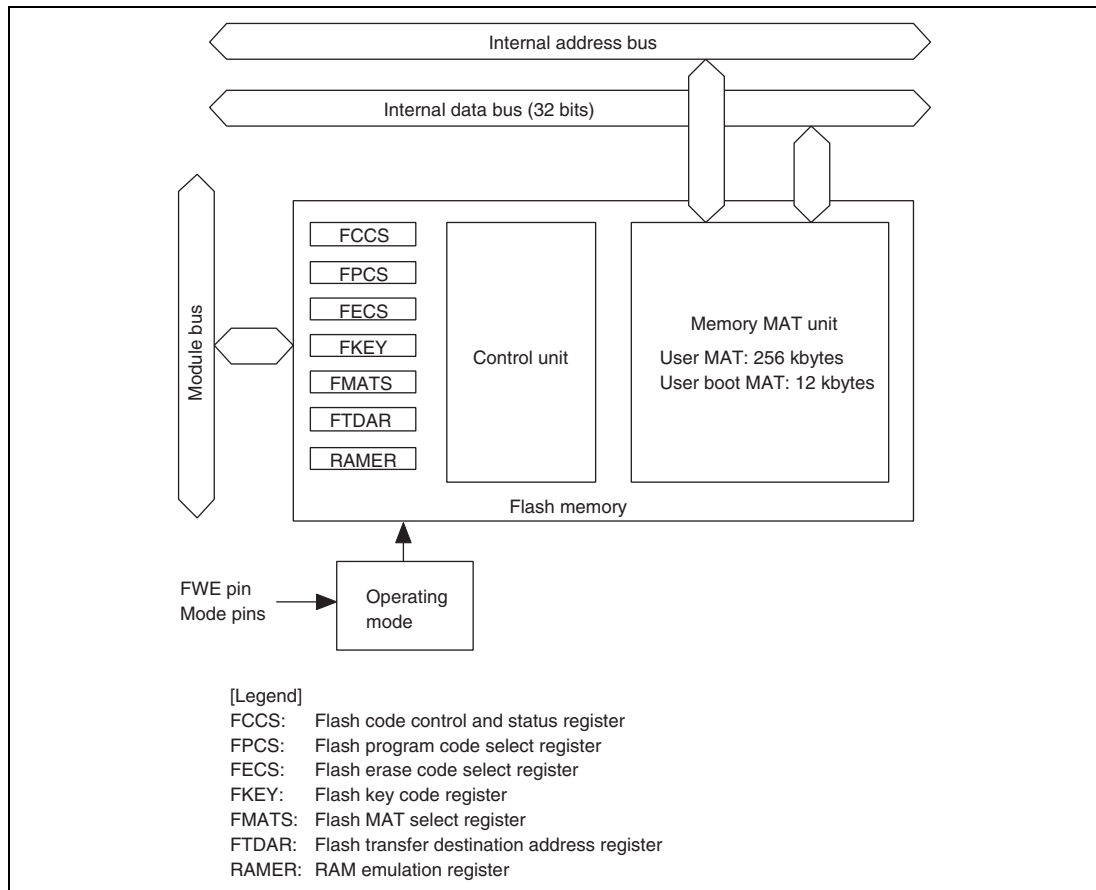

Figure 19.1 Block Diagram of Flash Memory

19.2.2 Operating Mode

When each mode pin and the FWE pin are set in the reset state and the reset signal is released, the microcomputer enters each operating mode as shown in figure 19.2. For the setting of each mode pin and the FWE pin, see table 19.1.

- Flash memory cannot be read, programmed, or erased in ROM invalid mode. The programming/erasing interface registers cannot be written to. When these registers are read, H'00 is always read.
- Flash memory can be read in user mode, but cannot be programmed or erased.
- Flash memory can be read, programmed, or erased on the board only in user program mode, user boot mode, and boot mode.
- Flash memory can be read, programmed, or erased by means of the PROM programmer in programmer mode.

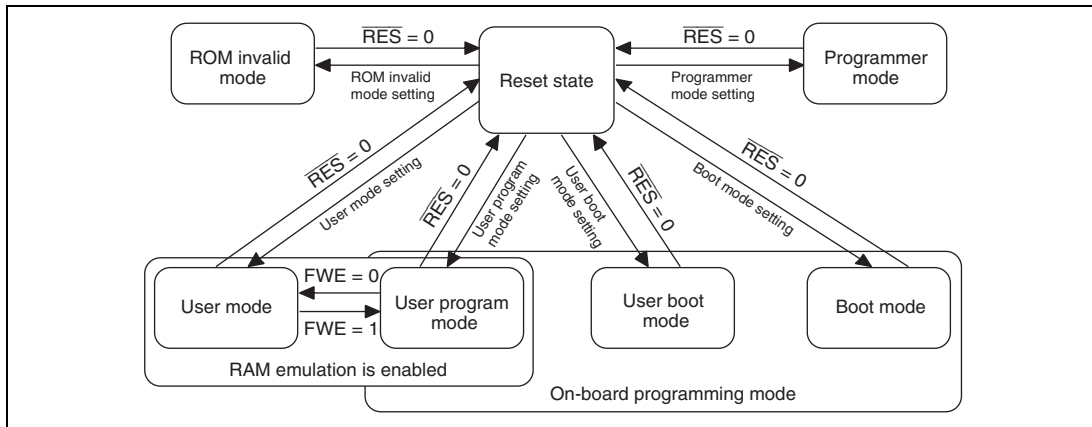

Figure 19.2 Mode Transition of Flash Memory

Table 19.1 (1) Relationship between FWE and MD Pins and Operating Modes (SH7146)

Pin	Reset State	User Mode	User Program Mode	Boot Mode	Programmer Mode
$\overline{\text{RES}}$	0	1	1	1	Setting value depends on the condition of the specialized PROM programmer.
FWE	0/1	0	1	1	
MD1	0/1	1	1	0	

Note: External bus extended mode and user boot mode are not supported by the SH7146.

Table 19.1 (2) Relationship between FWE and MD Pins and Operating Modes (SH7149)

Pin	Reset State	ROM Invalid Mode	User Mode	User Program Mode	User Boot Mode	Boot Mode	Programmer Mode
$\overline{\text{RES}}$	0	1	1	1	1	1	Setting value depends on the condition of the specialized PROM programmer.
FWE	0/1	0	0	1	1	1	
MD0	0/1	0/1* ¹	0/1* ²	0/1* ²	1	0	
MD1	0/1	0	1	1	0	0	

Notes: 1. MD0 = 0: 8-bit external bus, MD0 = 1: 16-bit external bus

2. MD0 = 0: External bus can be used, MD0 = 1: Single-chip mode (external bus cannot be used)

19.2.3 Mode Comparison

The comparison table of programming and erasing related items about boot mode, user program mode, user boot mode, and programmer mode is shown in table 19.2.

Table 19.2 Comparison of Programming Modes

	Boot Mode	User Program Mode	User Boot Mode	Programmer Mode
Programming/erasing environment	On-board programming			Off-board programming
Programming/erasing enable MAT	User MAT User boot MAT	User MAT	User MAT	User MAT User boot MAT
Programming/erasing control	Command method	Programming/erasing interface	Programming/erasing interface	—
All erasure	Possible (Automatic)	Possible	Possible	Possible (Automatic)
Block division erasure	Possible* ¹	Possible	Possible	Not possible
Program data transfer	From host via SCI	From optional device via RAM	From optional device via RAM	Via programmer
User branch function	Not possible	Possible	Possible	Not possible
RAM emulation	Not possible	Possible	Not possible	Not possible
Reset initiation MAT	Embedded program storage MAT	User MAT	User boot MAT* ²	Embedded program storage MAT
Transition to user mode	Mode setting change and reset	FWE setting change	Mode setting change and reset	—

Notes: 1. All-erasure is performed. After that, the specified block can be erased.

2. Initiation starts from the embedded program storage MAT. After checking the flash-memory related registers, initiation starts from the reset vector of the user MAT.

- The user boot MAT can be programmed or erased only in boot mode and programmer mode.
- The user MAT and user boot MAT are all erased in boot mode. Then, the user MAT and user boot MAT can be programmed by means of the command method. However, the contents of the MAT cannot be read until this state.
Only user boot MAT is programmed and the user MAT is programmed in user boot mode or only user MAT is programmed because user boot mode is not used.
- In user boot mode, the boot operation of the optional interface can be performed by a mode pin setting different from user program mode.

19.2.4 Flash Memory Configuration

This LSI's flash memory is configured by the 256-kbyte user MAT and 12-kbyte user boot MAT.

The start address is allocated to the same address in the user MAT and user boot MAT. Therefore, when the program execution or data access is performed between the two MATs, the MAT must be switched by using FMATS.

The user MAT or user boot MAT can be read in all modes if it is in ROM valid mode. However, the user boot MAT can be programmed only in boot mode and programmer mode.

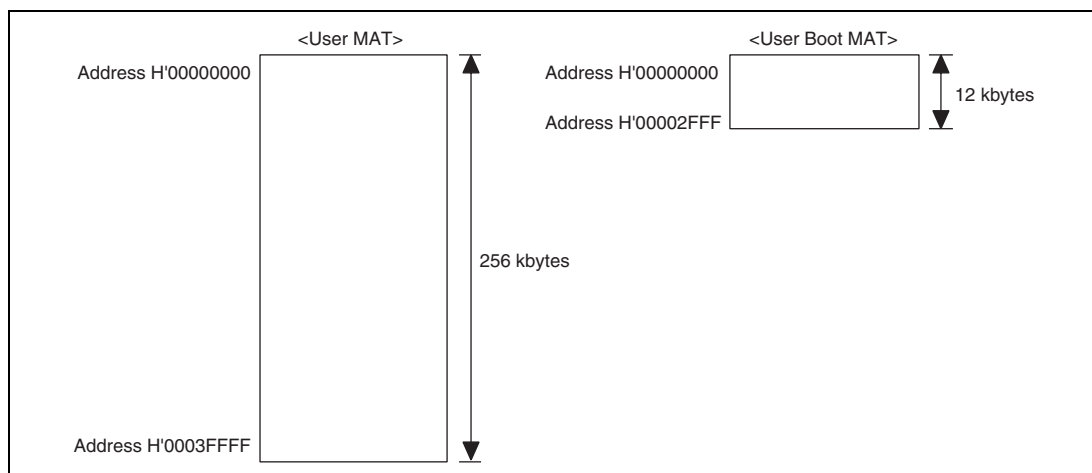

Figure 19.3 Flash Memory Configuration

The user MAT and user boot MAT have different memory sizes. Do not access a user boot MAT that is 12 kbytes or more. When a user boot MAT exceeding 12 kbytes is read from, an undefined value is read.

19.2.5 Block Division

The user MAT is divided into 64 kbytes (three blocks), 32 kbytes (one block), and 4 kbytes (eight blocks) as shown in figure 19.4. The user MAT can be erased in this divided-block units and the erase-block number of EB0 to EB11 is specified when erasing.

The RAM emulation can be performed in the eight blocks of 4 kbytes.

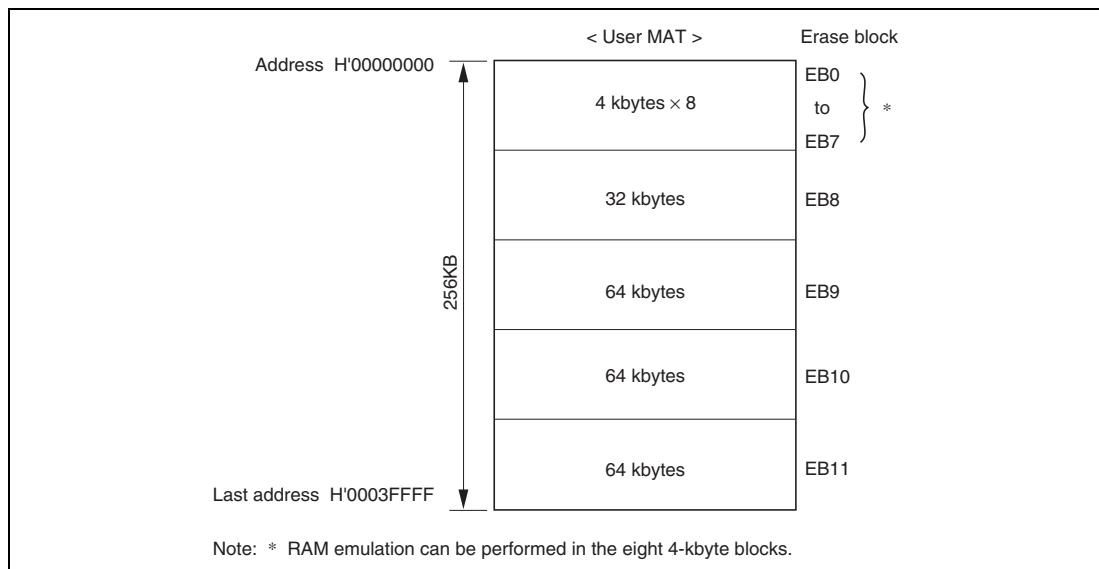

Figure 19.4 Block Division of User MAT

19.2.6 Programming/Erasing Interface

Programming/erasing is executed by downloading the on-chip program to the on-chip RAM and specifying the program address/data and erase block by using the interface registers/parameters.

The procedure program is made by the user in user program mode and user boot mode. The overview of the procedure is as follows. For details, see section 19.5.2, User Program Mode.

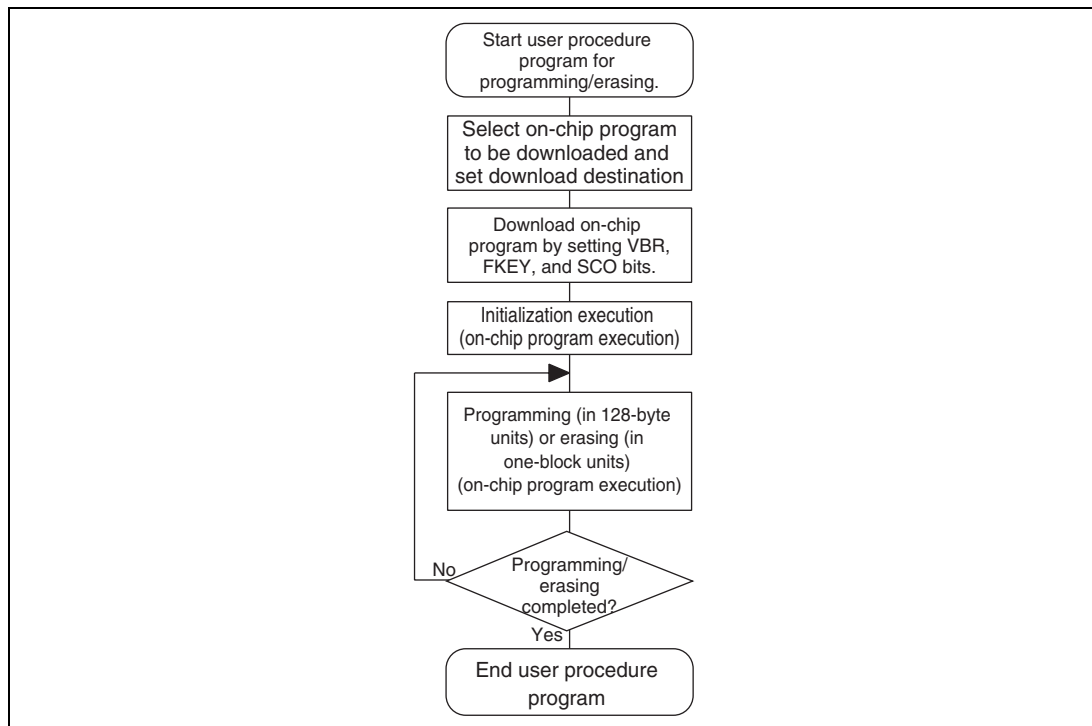

Figure 19.5 Overview of User Procedure Program

(1) Selection of On-Chip Program to be Downloaded and Setting of Download Destination

This LSI has programming/erasing programs and they can be downloaded to the on-chip RAM. The on-chip program to be downloaded is selected by setting the corresponding bits in the programming/erasing interface registers. The download destination can be specified by FTDAR.

(2) Download of On-Chip Program

The on-chip program is automatically downloaded by clearing VBR of the CPU to H'84000000 and then setting the SCO bit in the flash code control and status register (FCCS) and the flash key code register (FKEY), which are programming/erasing interface registers.

The user MAT is replaced to the embedded program storage area when downloading. Since the flash memory cannot be read when programming/erasing, the procedure program, which is working from download to completion of programming/erasing, must be executed in a space other than the flash memory to be programmed/erased (for example, on-chip RAM).

Since the result of download is returned to the programming/erasing interface parameters, whether the normal download is executed or not can be confirmed.

Note that VBR can be changed after download is completed.

(3) Initialization of Programming/Erasing

The operating frequency and user branch are set before execution of programming/erasing.

The user branch destination must be in an area other than the user MAT area which is in the middle of programming and the area where the on-chip program is downloaded. These settings are performed by using the programming/erasing interface parameters.

(4) Programming/Erasing Execution

To program or erase, the FWE pin must be brought high and user program mode must be entered.

The program data/programming destination address is specified in 128-byte units when programming.

The block to be erased is specified in erase-block units when erasing.

These specifications are set by using the programming/erasing interface parameters and the on-chip program is initiated. The on-chip program is executed by using the JSR or BSR instruction to perform the subroutine call of the specified address in the on-chip RAM. The execution result is returned to the programming/erasing interface parameters.

The area to be programmed must be erased in advance when programming flash memory.

There are limitations and notes on the interrupt processing during programming/erasing. For details, see section 19.8.2, Interrupts during Programming/Erasing.

(5) When Programming/Erasing is Executed Consecutively

When the processing is not ended by the 128-byte programming or one-block erasure, the program address/data and erase-block number must be updated and consecutive programming/erasing is required.

Since the downloaded on-chip program is left in the on-chip RAM after the processing, download and initialization are not required when the same processing is executed consecutively.

19.3 Input/Output Pins

Flash memory is controlled by the pins as shown in table 19.3.

Table 19.3 Pin Configuration

Name	Pin Name	Input/Output	Function
Power-on reset	$\overline{\text{RES}}$	Input	Reset
Flash programming enable	FWE	Input	Hardware protection when programming flash memory
Mode 1	MD1	Input	Sets operating mode of this LSI
Mode 0*	MD0	Input	Sets operating mode of this LSI
Transmit data	TXD1 (PA4)	Output	Serial transmit data output (used in boot mode)
Receive data	RXD1 (PA3)	Input	Serial receive data input (used in boot mode)

Note: * The SH7146 does not have the MD0 pin.

19.4 Register Descriptions

19.4.1 Registers

The registers/parameters which control flash memory when the on-chip flash memory is valid are shown in table 19.4.

There are several operating modes for accessing flash memory, for example, read mode/program mode.

There are two memory MATs: user MAT and user boot MAT. The dedicated registers/parameters are allocated for each operating mode and MAT selection. The correspondence of operating modes and registers/parameters for use is shown in table 19.5.

Table 19.4 (1) Register Configuration

Register Name	Abbreviation* ⁴	R/W	Initial Value	Address	Access Size
Flash code control and status register	FCCS	R, W* ¹	H'00* ² H'80* ²	H'FFFFCC00	8
Flash program code select register	FPCS	R/W	H'00	H'FFFFCC01	8
Flash erase code select register	FECS	R/W	H'00	H'FFFFCC02	8
Flash key code register	FKEY	R/W	H'00	H'FFFFCC04	8
Flash MAT select register	FMATS	R/W	H'00* ³ H'AA* ³	H'FFFFCC05	8
Flash transfer destination address register	FTDAR	R/W	H'00	H'FFFFCC06	8
RAM emulation register	RAMER	R/W	H'0000	H'FFFFF108	16

- Notes: 1. The bits except the SCO bit are read-only bits. The SCO bit is a programming-only bit. (The value that can be read is always 0.)
2. The initial value of the FWE bit is 0 when the FWE pin goes low. The initial value of the FWE bit is 1 when the FWE pin goes high.
3. The initial value at initiation in user mode or user program mode is H'00. The initial value at initiation in user boot mode is H'AA.
4. All registers except for RAMER can be accessed only in bytes. RAMER can be accessed in bytes or words.

Table 19.4 (2) Parameter Configuration

Name	Abbreviation	R/W	Initial Value	Address	Access Size
Download pass/fail result	DPFR	R/W	Undefined	On-chip RAM*	8, 16, 32
Flash pass/fail result	FPFR	R/W	Undefined	R0 of CPU	8, 16, 32
Flash multipurpose address area	FMPAR	R/W	Undefined	R5 of CPU	8, 16, 32
Flash multipurpose data destination area	FMPDR	R/W	Undefined	R4 of CPU	8, 16, 32
Flash erase block select	FEBS	R/W	Undefined	R4 of CPU	8, 16, 32
Flash program and erase frequency control	FPEFEQ	R/W	Undefined	R4 of CPU	8, 16, 32
Flash user branch address set parameter	FUBRA	R/W	Undefined	R5 of CPU	8, 16, 32

Note: * One byte of the start address in the on-chip RAM area specified by FTDAR is valid.

Table 19.5 Register/Parameter and Target Mode

		Download	Initiali- zation	Program- ming	Erase	Read	RAM Emulation
Programming/ erasing interface registers	FCCS	√	—	—	—	—	—
	FPCS	√	—	—	—	—	—
	PECS	√	—	—	—	—	—
	FKEY	√	—	√	√	—	—
	FMATS	—	—	√* ¹	√* ¹	√* ²	—
	FTDAR	√	—	—	—	—	—
Programming/ erasing interface parameters	DPFR	√	—	—	—	—	—
	FPFR	—	√	√	√	—	—
	FPEFEQ	—	√	—	—	—	—
	FUBRA	—	√	—	—	—	—
	FMPAR	—	—	√	—	—	—
	FMPDR	—	—	√	—	—	—
	FEBS	—	—	—	√	—	—
RAM emulation	RAMER	—	—	—	—	—	√

Notes: 1. The setting is required when programming or erasing user MAT in user boot mode.

2. The setting may be required according to the combination of initiation mode and read target MAT.

19.4.2 Programming/Erasing Interface Registers

The programming/erasing interface registers are as described below. They are all 8-bit registers that can be accessed in bytes.

(1) Flash Code Control and Status Register (FCCS)

FCCS is configured by bits which request the monitor of the FWE pin state and error occurrence during programming or erasing flash memory and the download of the on-chip program.

Bit:	7	6	5	4	3	2	1	0
	FWE	MAT	-	FLER	-	-	-	SCO
Initial value:	1/0	1/0	0	0	0	0	0	0
R/W:	R	R	R	R	R	R	R	(R)/W

Bit	Bit Name	Initial Value	R/W	Description
7	FWE	1/0	R	Flash Programming Enable Monitors the level, which is input to the FWE pin that performs hardware protection of the flash memory programming or erasing. The initial value is 0 or 1 according to the FWE pin state. 0: When the FWE pin goes low (in hardware protection state) 1: When the FWE pin goes high
6	MAT	1/0	R	MAT Bit Indicates whether the user MAT or user boot MAT is selected. 0: User MAT is selected 1: User boot MAT is selected
5	—	0	R	Reserved This bit is always read as 0. The write value should always be 0.

Bit	Bit Name	Initial Value	R/W	Description
4	FLER	0	R	<p>Flash Memory Error</p> <p>Indicates an error occurs during programming and erasing flash memory.</p> <p>When FLER is set to 1, flash memory enters the error protection state.</p> <p>When FLER is set to 1, high voltage is applied to the internal flash memory. To reduce the damage to flash memory, the reset signal must be released after the reset period of 100 μs, which is longer than normal.</p> <p>0: Flash memory operates normally Programming/erasing protection for flash memory (error protection) is invalid.</p> <p>[Clearing condition] At a power-on reset</p> <p>1: Indicates an error occurs during programming/erasing flash memory. Programming/erasing protection for flash memory (error protection) is valid.</p> <p>[Setting condition] See section 19.6.3, Error Protection.</p>
3 to 1	—	All 0	R	<p>Reserved</p> <p>These bits are always read as 0. The write value should always be 0.</p>

Bit	Bit Name	Initial Value	R/W	Description
0	SCO	0	(R)/W	<p>Source Program Copy Operation</p> <p>Requests the on-chip programming/erasing program to be downloaded to the on-chip RAM.</p> <p>When this bit is set to 1, the on-chip program which is selected by FPCS/FECS is automatically downloaded in the on-chip RAM area specified by FTDAR.</p> <p>In order to set this bit to 1, RAM emulation state must be canceled, H'A5 must be written to FKEY, and this operation must be in the on-chip RAM.</p> <p>Four NOP instructions must be executed immediately after setting this bit to 1.</p> <p>For interrupts during download, see section 19.8.2, Interrupts during Programming/Erasing. For the download time, see section 19.8.3, Other Notes.</p> <p>Since this bit is cleared to 0 when download is completed, this bit cannot be read as 1.</p> <p>Download by setting the SCO bit to 1 requires a special interrupt processing that performs bank switching to the on-chip program storage area. Therefore, before issuing a download request (SCO = 1), set VBR to H'84000000. Otherwise, the CPU gets out of control. Once download end is confirmed, VBR can be changed to any other value.</p> <p>The mode in which the FWE pin is high must be used when using the SCO function.</p> <p>0: Download of the on-chip programming/erasing program to the on-chip RAM is not executed.</p> <p>[Clearing condition]</p> <p>When download is completed</p> <p>1: Request that the on-chip programming/erasing program is downloaded to the on-chip RAM is generated</p> <p>[Setting conditions]</p> <p>When all of the following conditions are satisfied and 1 is written to this bit</p> <ul style="list-style-type: none"> • FKEY is written to H'A5 • During execution in the on-chip RAM • Not in RAM emulation mode (RAMS in RAMCR = 0)

(2) Flash Program Code Select Register (FPCS)

FPCS selects the on-chip programming program to be downloaded.

Bit:	7	6	5	4	3	2	1	0
	-	-	-	-	-	-	-	PPVS
Initial value:	0	0	0	0	0	0	0	0
R/W:	R	R	R	R	R	R	R	R/W

Bit	Bit Name	Initial Value	R/W	Description
7 to 1	—	All 0	R	Reserved These bits are always read as 0. The write value should always be 0.
0	PPVS	0	R/W	Program Pulse Single Selects the programming program. 0: On-chip programming program is not selected [Clearing condition] When transfer is completed 1: On-chip programming program is selected

(3) Flash Erase Code Select Register (FECS)

FECS selects download of the on-chip erasing program.

Bit:	7	6	5	4	3	2	1	0
	-	-	-	-	-	-	-	EPVB
Initial value:	0	0	0	0	0	0	0	0
R/W:	R	R	R	R	R	R	R	R/W

Bit	Bit Name	Initial Value	R/W	Description
7 to 1	—	All 0	R	Reserved These bits are always read as 0. The write value should always be 0.

Bit	Bit Name	Initial Value	R/W	Description
0	EPVB	0	R/W	Erase Pulse Verify Block Selects the erasing program. 0: On-chip erasing program is not selected [Clearing condition] When transfer is completed 1: On-chip erasing program is selected

(4) Flash Key Code Register (FKEY)

FKEY is a register for software protection that enables download of the on-chip program and programming/erasing of flash memory. Before setting the SCO bit to 1 in order to download the on-chip program or executing the downloaded programming/erasing program, these processing cannot be executed if the key code is not written.

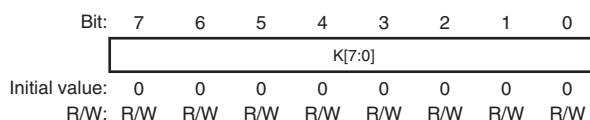

Bit	Bit Name	Initial Value	R/W	Description
7 to 0	K[7:0]	All 0	R/W	Key Code Only when H'A5 is written, writing to the SCO bit is valid. When a value other than H'A5 is written to FKEY, 1 cannot be written to the SCO bit. Therefore downloading to the on-chip RAM cannot be executed. Only when H'5A is written, programming/erasing of flash memory can be executed. Even if the on-chip programming/erasing program is executed, flash memory cannot be programmed or erased when a value other than H'5A is written to FKEY. H'A5: Writing to the SCO bit is enabled (The SCO bit cannot be set by a value other than H'A5.) H'5A: Programming/erasing is enabled (A value other than H'5A enables software protection state.) H'00: Initial value

(5) Flash MAT Select Register (FMATS)

FMATS specifies whether user MAT or user boot MAT is selected.

Bit:	7	6	5	4	3	2	1	0
	MS7	MS6	MS5	MS4	MS3	MS2	MS1	MS0
Initial value:	0/1	0	0/1	0	0/1	0	0/1	0
R/W:	R/W	R/W	R/W	R/W	R/W	R/W	R/W	R/W

Bit	Bit Name	Initial Value	R/W	Description
7	MS7	0/1	R/W	MAT Select
6	MS6	0	R/W	These bits are in user-MAT selection state when a value other than H'AA is written and in user-boot-MAT selection state when H'AA is written.
5	MS5	0/1	R/W	
4	MS4	0	R/W	The MAT is switched by writing a value in FMATS with the on-chip RAM instruction.
3	MS3	0/1	R/W	
2	MS2	0	R/W	When the MAT is switched, follow section 19.8.1, Switching between User MAT and User Boot MAT. (The user boot MAT cannot be programmed in user program mode if user boot MAT is selected by FMATS. The user boot MAT must be programmed in boot mode or in programmer mode.)
1	MS1	0/1	R/W	
0	MS0	0	R/W	<p>H'AA: The user boot MAT is selected (in user-MAT selection state when the value of these bits are other than H'AA) Initial value when these bits are initiated in user boot mode.</p> <p>H'00: Initial value when these bits are initiated in a mode except for user boot mode (in user-MAT selection state)</p> <p>[Programmable condition]</p> <p>These bits are in the execution state in the on-chip RAM.</p>

(6) Flash Transfer Destination Address Register (FTDAR)

FTDAR specifies the on-chip RAM address to which the on-chip program is downloaded.

Make settings for FTDAR before writing 1 to the SCO bit in FCCS. The initial value is H'00 which points to the start address (H'FFFF9000) in on-chip RAM.

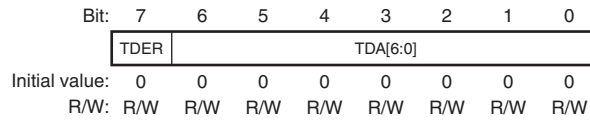

Bit	Bit Name	Initial Value	R/W	Description
7	TDER	0	R/W	<p>Transfer Destination Address Setting Error</p> <p>This bit is set to 1 when there is an error in the download start address set by bits 6 to 0 (TDA6 to TDA0). Whether the address setting is erroneous or not is tested by checking whether the setting of TDA6 to TDA0 is in the range of H'00 to H'02 after setting the SCO bit in FCCS to 1 and performing download. Before setting the SCO bit to 1 be sure to set the FTDAR value between H'00 to H'02 as well as clearing this bit to 0.</p> <p>0: Setting of TDA6 to TDA0 is normal 1: Setting of TDER and TDA6 to TDA0 is H'03 to H'FF and download has been aborted</p>
6 to 0	TDA[6:0]	All 0	R/W	<p>Transfer Destination Address</p> <p>These bits specify the download start address. A value from H'00 to H'02 can be set to specify the download start address in on-chip RAM in 2-kbyte units.</p> <p>A value from H'03 to H'7F cannot be set. If such a value is set, the TDER bit (bit 7) in this register is set to 1 to prevent download from being executed.</p> <p>H'00: Download start address is set to H'FFFF9000 H'01: Download start address is set to H'FFFF9800 H'02: Download start address is set to H'FFFA000 H'03 to H'7F: Setting prohibited. If this value is set, the TDER bit (bit 7) is set to 1 to abort the download processing.</p>

19.4.3 Programming/Erasing Interface Parameters

The programming/erasing interface parameters specify the operating frequency, user branch destination address, storage place for program data, programming destination address, and erase block and exchanges the processing result for the downloaded on-chip program. This parameter uses the general registers of the CPU (R4, R5, and R0) or the on-chip RAM area. The initial value is undefined.

At download all CPU registers are stored, and at initialization or when the on-chip program is executed, CPU registers except for R0 are stored. The return value of the processing result is written in R0. Since the stack area is used for storing the registers or as a work area, the stack area must be saved at the processing start. (The maximum size of a stack area to be used is 128 bytes.)

The programming/erasing interface parameters are used in the following four items.

1. Download control
2. Initialization before programming or erasing
3. Programming
4. Erasing

These items use different parameters. The correspondence table is shown in table 19.6.

The processing results of initialization, programming, and erasing are returned, but the bit contents have different meanings according to the processing program. See the description of FPF8 for each processing.

Table 19.6 Usable Parameters and Target Modes

Name of Parameter	Abbreviation	Download	Initialization	Programming	Erasure	R/W	Initial Value	Allocation
Download pass/fail result	DPFR	√	—	—	—	R/W	Undefined	On-chip RAM*
Flash pass/fail result	FPFR	—	√	√	√	R/W	Undefined	R0 of CPU
Flash programming/erasing frequency control	FPEFEQ	—	√	—	—	R/W	Undefined	R4 of CPU
Flash user branch address set	FUBRA	—	√	—	—	R/W	Undefined	R5 of CPU
Flash multipurpose address area	FMPAR	—	—	√	—	R/W	Undefined	R5 of CPU
Flash multipurpose data destination area	FMPDR	—	—	√	—	R/W	Undefined	R4 of CPU
Flash erase block select	FEBS	—	—	—	√	R/W	Undefined	R4 of CPU

Note: * One byte of start address of download destination specified by FTDAR

(1) Download Control

The on-chip program is automatically downloaded by setting the SCO bit to 1. The on-chip RAM area to be downloaded is the area as much as 3 kbytes starting from the start address specified by FTDAR. For the address map of the on-chip RAM, see figure 19.10.

The download control is set by using the programming/erasing interface registers. The return value is given by the DPFR parameter.

- (a) Download pass/fail result parameter (DPFR: one byte of start address of on-chip RAM specified by FTDAR)

This parameter indicates the return value of the download result. The value of this parameter can be used to determine if downloading is executed or not. Since the confirmation whether the SCO bit is set to 1 is difficult, the certain determination must be performed by setting one byte of the start address of the on-chip RAM area specified by FTDAR to a value other than the return value of download (for example, H'FF) before the download start (before setting the SCO bit to 1). For the checking method of download results, see section 19.5.2 (2), Programming Procedure in User Program Mode.

Bit:	7	6	5	4	3	2	1	0
	-	-	-	-	-	SS	FK	SF
Initial value:	-	-	-	-	-	-	-	-
R/W:	R/W	R/W	R/W	R/W	R/W	R/W	R/W	R/W

Bit	Bit Name	Initial Value	R/W	Description
7 to 3	—	Undefined	R/W	Unused Return 0.
2	SS	Undefined	R/W	Source Select Error Detect The on-chip program which can be downloaded can be specified as only one type. When more than two types of the program are selected, the program is not selected, or the program is selected without mapping, an error occurs. 0: Download program can be selected normally 1: Download error occurs (Multi-selection or program which is not mapped is selected)
1	FK	Undefined	R/W	Flash Key Register Error Detect Returns the check result whether the value of FKEY is set to H'A5. 0: FKEY setting is normal (FKEY = H'A5) 1: FKEY setting is abnormal (FKEY = value other than H'A5)
0	SF	Undefined	R/W	Success/Fail Returns the result whether download has ended normally or not. 0: Downloading on-chip program has ended normally (no error) 1: Downloading on-chip program has ended abnormally (error occurs)

(2) Programming/Erasing Initialization

The on-chip programming/erasing program to be downloaded includes the initialization program.

The specified period pulse must be applied when programming or erasing. The specified pulse width is made by the method in which wait loop is configured by the CPU instruction. The operating frequency of the CPU must be set. Since the user branch function is supported, the user branch destination address must be set.

The initial program is set as a parameter of the programming/erasing program which has downloaded these settings.

(2.1) Flash programming/erasing frequency parameter (FPEFEQ: general register R4 of CPU)

This parameter sets the operating frequency of the CPU.

For the range of the operating frequency of this LSI, see table 24.4, Maximum Operating Frequency.

Bit:	31	30	29	28	27	26	25	24	23	22	21	20	19	18	17	16
	-	-	-	-	-	-	-	-	-	-	-	-	-	-	-	-
Initial value:	-	-	-	-	-	-	-	-	-	-	-	-	-	-	-	-
R/W:	R/W	R/W	R/W	R/W	R/W	R/W	R/W	R/W	R/W	R/W	R/W	R/W	R/W	R/W	R/W	R/W
Bit:	15	14	13	12	11	10	9	8	7	6	5	4	3	2	1	0
	F15	F14	F13	F12	F11	F10	F9	F8	F7	F6	F5	F4	F3	F2	F1	F0
Initial value:	-	-	-	-	-	-	-	-	-	-	-	-	-	-	-	-
R/W:	R/W	R/W	R/W	R/W	R/W	R/W	R/W	R/W	R/W	R/W	R/W	R/W	R/W	R/W	R/W	R/W

Bit	Bit Name	Initial Value	R/W	Description
31 to 16	—	Undefined	R/W	Unused Return 0.
15 to 0	F15 to F0	Undefined	R/W	<p>Frequency Set</p> <p>Set the operating frequency of the CPU. The setting value must be calculated as the following methods.</p> <ol style="list-style-type: none"> The operating frequency which is shown in MHz units must be rounded in a number to three decimal places and be shown in a number of two decimal places. The centuplicated value is converted to the binary digit and is written to the FPEFEQ parameter (general register R4). For example, when the operating frequency of the CPU is 28.882 MHz, the value is as follows. <ul style="list-style-type: none"> — The number to three decimal places of 28.882 is rounded and the value is thus 28.88. — The formula that $28.88 \times 100 = 2888$ is converted to the binary digit and B'0000, B'1011, B'0100, B'1000 (H'0B48) is set to B'R4.

(2.2) Flash user branch address setting parameter (FUBRA: general register R5 of CPU)

This parameter sets the user branch destination address. The user program which has been set can be executed in specified processing units when programming and erasing.

Bit:	31	30	29	28	27	26	25	24	23	22	21	20	19	18	17	16
	UA31	UA30	UA29	UA28	UA27	UA26	UA25	UA24	UA23	UA22	UA21	UA20	UA19	UA18	UA17	UA16
Initial value:	-	-	-	-	-	-	-	-	-	-	-	-	-	-	-	-
R/W:	R/W	R/W	R/W	R/W	R/W	R/W	R/W	R/W	R/W	R/W	R/W	R/W	R/W	R/W	R/W	R/W
Bit:	15	14	13	12	11	10	9	8	7	6	5	4	3	2	1	0
	UA15	UA14	UA13	UA12	UA11	UA10	UA9	UA8	UA7	UA6	UA5	UA4	UA3	UA2	UA1	UA0
Initial value:	-	-	-	-	-	-	-	-	-	-	-	-	-	-	-	-
R/W:	R/W	R/W	R/W	R/W	R/W	R/W	R/W	R/W	R/W	R/W	R/W	R/W	R/W	R/W	R/W	R/W

Bit	Bit Name	Initial Value	R/W	Description
31 to 0	UA31 to UA0	Undefined	R/W	<p>User Branch Destination Address</p> <p>When the user branch is not required, address 0 (H'00000000) must be set.</p> <p>The user branch destination must be an area other than the flash memory, an area other than the RAM area in which on-chip program has been transferred, or the external bus space.</p> <p>Note that the CPU must not branch to an area without the execution code and get out of control. The on-chip program download area and stack area must not be overwritten. If CPU runaway occurs or the download area or stack area is overwritten, the value of flash memory cannot be guaranteed.</p> <p>The download of the on-chip program, initialization, initiation of the programming/erasing program must not be executed in the processing of the user branch destination. Programming or erasing cannot be guaranteed when returning from the user branch destination. The program data which has already been prepared must not be programmed.</p> <p>Store general registers R8 to R15. General registers R0 to R7 are available without storing them.</p> <p>Moreover, the programming/erasing interface registers must not be written to or RAM emulation mode must not be entered in the processing of the user branch destination.</p> <p>After the processing of the user branch has ended, the programming/erasing program must be returned to by using the RTS instruction.</p> <p>For the execution intervals of the user branch processing, see note 2 (User branch processing intervals) in section 19.8.3, Other Notes.</p>

(2.3) Flash pass/fail result parameter (FPFR: general register R0 of CPU)

This parameter indicates the return value of the initialization result.

Bit:	31	30	29	28	27	26	25	24	23	22	21	20	19	18	17	16
	-	-	-	-	-	-	-	-	-	-	-	-	-	-	-	-
Initial value:	-	-	-	-	-	-	-	-	-	-	-	-	-	-	-	-
R/W:	R/W	R/W	R/W	R/W	R/W	R/W	R/W	R/W	R/W	R/W	R/W	R/W	R/W	R/W	R/W	R/W

Bit:	15	14	13	12	11	10	9	8	7	6	5	4	3	2	1	0
	-	-	-	-	-	-	-	-	-	-	-	-	-	BR	FQ	SF
Initial value:	-	-	-	-	-	-	-	-	-	-	-	-	-	-	-	-
R/W:	R/W	R/W	R/W	R/W	R/W	R/W	R/W	R/W	R/W	R/W	R/W	R/W	R/W	R/W	R/W	R/W

Bit	Bit Name	Initial Value	R/W	Description
31 to 3	—	Undefined	R/W	Unused Return 0.
2	BR	Undefined	R/W	User Branch Error Detect Returns the check result whether the specified user branch destination address is in the area other than the storage area of the programming/erasing program which has been downloaded. 0: User branch address setting is normal 1: User branch address setting is abnormal
1	FQ	Undefined	R/W	Frequency Error Detect Returns the check result whether the specified operating frequency of the CPU is in the range of the supported operating frequency. 0: Setting of operating frequency is normal 1: Setting of operating frequency is abnormal
0	SF	Undefined	R/W	Success/Fail Indicates whether initialization is completed normally. 0: Initialization has ended normally (no error) 1: Initialization has ended abnormally (error occurs)

(3) Programming Execution

When flash memory is programmed, the programming destination address and programming data on the user MAT must be passed to the programming program in which the program data is downloaded.

1. The start address of the programming destination on the user MAT is set in general register R5 of the CPU. This parameter is called FMPAR (flash multipurpose address area parameter).

Since the program data is always in 128-byte units, the lower eight bits (MOA7 to MOA0) must be H'00 or H'80 as the boundary of the programming start address on the user MAT.

2. The program data for the user MAT must be prepared in the consecutive area. The program data must be in the consecutive space, which can be accessed by using the MOV.B instruction of the CPU, and is not the flash memory space.

When data to be programmed does not satisfy 128 bytes, the 128-byte program data must be prepared by embedding the dummy code (H'FF).

The start address of the area in which the prepared program data is stored must be set in general register R4. This parameter is called FMPDR (flash multipurpose data destination area parameter).

For details on the programming procedure, see section 19.5.2, User Program Mode.

(3.1) Flash multipurpose address area parameter (FMPAR: general register R5 of CPU)

This parameter indicates the start address of the programming destination on the user MAT.

When an address in an area other than the flash memory space is set, an error occurs.

The start address of the programming destination must be at the 128-byte boundary. If this boundary condition is not satisfied, an error occurs. The error occurrence is indicated by the WA bit (bit 1) in FPPR.

Bit:	31	30	29	28	27	26	25	24	23	22	21	20	19	18	17	16
	MOA31	MOA30	MOA29	MOA28	MOA27	MOA26	MOA25	MOA24	MOA23	MOA22	MOA21	MOA20	MOA19	MOA18	MOA17	MOA16
Initial value:	-	-	-	-	-	-	-	-	-	-	-	-	-	-	-	-
R/W:	R/W	R/W	R/W	R/W	R/W	R/W	R/W	R/W	R/W	R/W	R/W	R/W	R/W	R/W	R/W	R/W

Bit:	15	14	13	12	11	10	9	8	7	6	5	4	3	2	1	0
	MOA15	MOA14	MOA13	MOA12	MOA11	MOA10	MOA9	MOA8	MOA7	MOA6	MOA5	MOA4	MOA3	MOA2	MOA1	MOA0
Initial value:	-	-	-	-	-	-	-	-	-	-	-	-	-	-	-	-
R/W:	R/W	R/W	R/W	R/W	R/W	R/W	R/W	R/W	R/W	R/W	R/W	R/W	R/W	R/W	R/W	R/W

Bit	Bit Name	Initial Value	R/W	Description
31 to 0	MOA31 to MOA0	Undefined	R/W	MOA31 to MOA0 Store the start address of the programming destination on the user MAT. The consecutive 128-byte programming is executed starting from the specified start address of the user MAT. The MOA6 to MOA0 bits are always 0 because the start address of the programming destination is at the 128-byte boundary.

(3.2) Flash multipurpose data destination area parameter (FMPDR: general register R4 of CPU)

This parameter indicates the start address in the area, which stores the data to be programmed in the user MAT. When the storage destination of the program data is in flash memory, an error occurs. The error occurrence is indicated by the WD bit (bit 2) in FPFR.

Bit:	31	30	29	28	27	26	25	24	23	22	21	20	19	18	17	16
	MOD31	MOD30	MOD29	MOD28	MOD27	MOD26	MOD25	MOD24	MOD23	MOD22	MOD21	MOD20	MOD19	MOD18	MOD17	MOD16
Initial value:	-	-	-	-	-	-	-	-	-	-	-	-	-	-	-	-
R/W:	R/W	R/W	R/W	R/W	R/W	R/W	R/W	R/W	R/W	R/W	R/W	R/W	R/W	R/W	R/W	R/W

Bit:	15	14	13	12	11	10	9	8	7	6	5	4	3	2	1	0
	MOD15	MOD14	MOD13	MOD12	MOD11	MOD10	MOD9	MOD8	MOD7	MOD6	MOD5	MOD4	MOD3	MOD2	MOD1	MOD0
Initial value:	-	-	-	-	-	-	-	-	-	-	-	-	-	-	-	-
R/W:	R/W	R/W	R/W	R/W	R/W	R/W	R/W	R/W	R/W	R/W	R/W	R/W	R/W	R/W	R/W	R/W

Bit	Bit Name	Initial Value	R/W	Description
31 to 0	MOD31 to MOD0	Undefined	R/W	MOD31 to MOD0 Store the start address of the area which stores the program data for the user MAT. The consecutive 128-byte data is programmed to the user MAT starting from the specified start address.

(3.3) Flash pass/fail result parameter (FPFR: general register R0 of CPU)

This parameter indicates the return value of the program processing result.

Bit:	31	30	29	28	27	26	25	24	23	22	21	20	19	18	17	16
	-	-	-	-	-	-	-	-	-	-	-	-	-	-	-	-
Initial value:	-	-	-	-	-	-	-	-	-	-	-	-	-	-	-	-
R/W:	R/W	R/W	R/W	R/W	R/W	R/W	R/W	R/W	R/W	R/W	R/W	R/W	R/W	R/W	R/W	R/W
Bit:	15	14	13	12	11	10	9	8	7	6	5	4	3	2	1	0
	-	-	-	-	-	-	-	-	-	MD	EE	FK	-	WD	WA	SF
Initial value:	-	-	-	-	-	-	-	-	-	-	-	-	-	-	-	-
R/W:	R/W	R/W	R/W	R/W	R/W	R/W	R/W	R/W	R/W	R/W	R/W	R/W	R/W	R/W	R/W	R/W

Bit	Bit Name	Initial Value	R/W	Description
31 to 7	—	Undefined	R/W	Unused Return 0.
6	MD	Undefined	R/W	<p>Programming Mode Related Setting Error Detect</p> <p>Returns the check result of whether the signal input to the FWE pin is high and whether the error protection state is not entered.</p> <p>When a low-level signal is input to the FWE pin or the error protection state is entered, 1 is written to this bit. The input level to the FWE pin and the error protection state can be confirmed with the FWE bit (bit 7) and the FLER bit (bit 4) in FCCS, respectively. For conditions to enter the error protection state, see section 19.6.3, Error Protection.</p> <p>0: FWE and FLER settings are normal (FWE = 1, FLER = 0)</p> <p>1: FWE = 0 or FLER = 1, and programming cannot be performed</p>

Bit	Bit Name	Initial Value	R/W	Description
5	EE	Undefined	R/W	<p>Programming Execution Error Detect</p> <p>1 is returned to this bit when the specified data could not be written because the user MAT was not erased or when flash-memory related register settings are partially changed on returning from the user branch processing.</p> <p>If this bit is set to 1, there is a high possibility that the user MAT is partially rewritten. In this case, after removing the error factor, erase the user MAT.</p> <p>If FMATS is set to H'AA and the user boot MAT is selected, an error occurs when programming is performed. In this case, both the user MAT and user boot MAT are not rewritten.</p> <p>Programming of the user boot MAT must be executed in boot mode or programmer mode.</p> <p>0: Programming has ended normally 1: Programming has ended abnormally (programming result is not guaranteed)</p>
4	FK	Undefined	R/W	<p>Flash Key Register Error Detect</p> <p>Returns the check result of the value of FKEY before the start of the programming processing.</p> <p>0: FKEY setting is normal (FKEY = H'5A) 1: FKEY setting is error (FKEY = value other than H'5A)</p>
3	—	Undefined	R/W	<p>Unused</p> <p>Return 0.</p>
2	WD	Undefined	R/W	<p>Write Data Address Error Detect</p> <p>When an address in the flash memory area is specified as the start address of the storage destination of the program data, an error occurs.</p> <p>0: Setting of write data address is normal 1: Setting of write data address is abnormal</p>

Bit	Bit Name	Initial Value	R/W	Description
1	WA	Undefined	R/W	<p>Write Address Error Detect</p> <p>When the following items are specified as the start address of the programming destination, an error occurs.</p> <ul style="list-style-type: none">• The programming destination address is an area other than flash memory• The specified address is not at the 128-byte boundary (A6 to A0 are not 0) <p>0: Setting of programming destination address is normal 1: Setting of programming destination address is abnormal</p>
0	SF	Undefined	R/W	<p>Success/Fail</p> <p>Indicates whether the program processing has ended normally or not.</p> <p>0: Programming has ended normally (no error) 1: Programming has ended abnormally (error occurs)</p>

(4) Erasure Execution

When flash memory is erased, the erase-block number on the user MAT must be passed to the erasing program, which is downloaded. This is set to the FEBS parameter (general register R4).

One block is specified from the block number 0 to 15.

For details on the erasing procedure, see section 19.5.2, User Program Mode.

(4.1) Flash erase block select parameter (FEBS: general register R4 of CPU)

This parameter specifies the erase-block number. Several block numbers cannot be specified.

Bit:	31	30	29	28	27	26	25	24	23	22	21	20	19	18	17	16
	-	-	-	-	-	-	-	-	-	-	-	-	-	-	-	-
Initial value:	-	-	-	-	-	-	-	-	-	-	-	-	-	-	-	-
R/W:	R/W	R/W	R/W	R/W	R/W	R/W	R/W	R/W	R/W	R/W	R/W	R/W	R/W	R/W	R/W	R/W
Bit:	15	14	13	12	11	10	9	8	7	6	5	4	3	2	1	0
	-	-	-	-	-	-	-	-	EBS[7:0]							
Initial value:	-	-	-	-	-	-	-	-	-	-	-	-	-	-	-	-
R/W:	R/W	R/W	R/W	R/W	R/W	R/W	R/W	R/W	R/W	R/W	R/W	R/W	R/W	R/W	R/W	R/W

Bit	Bit Name	Initial Value	R/W	Description
31 to 8	—	Undefined	R/W	Unused Return 0.
7 to 0	EBS[7:0]	Undefined	R/W	Set the erase-block number in the range from 0 to 11. 0 corresponds to the EB0 block and 11 corresponds to the EB11 block. An error occurs when a number other than 0 to 11 (H'00 to H'0B) is set.

(4.2) Flash pass/fail result parameter (FPFR: general register R0 of CPU)

This parameter returns the value of the erasing processing result.

Bit:	31	30	29	28	27	26	25	24	23	22	21	20	19	18	17	16
	-	-	-	-	-	-	-	-	-	-	-	-	-	-	-	-
Initial value:	-	-	-	-	-	-	-	-	-	-	-	-	-	-	-	-
R/W:	R/W	R/W	R/W	R/W	R/W	R/W	R/W	R/W	R/W	R/W	R/W	R/W	R/W	R/W	R/W	R/W
Bit:	15	14	13	12	11	10	9	8	7	6	5	4	3	2	1	0
	-	-	-	-	-	-	-	-	-	MD	EE	FK	EB	-	-	SF
Initial value:	-	-	-	-	-	-	-	-	-	-	-	-	-	-	-	-
R/W:	R/W	R/W	R/W	R/W	R/W	R/W	R/W	R/W	R/W	R/W	R/W	R/W	R/W	R/W	R/W	R/W

Bit	Bit Name	Initial Value	R/W	Description
31 to 7	—	Undefined	R/W	Unused Return 0.
6	MD	Undefined	R/W	<p>Erasure Mode Related Setting Error Detect</p> <p>Returns the check result of whether the signal input to the FWE pin is high and whether the error protection state is not entered.</p> <p>When a low-level signal is input to the FWE pin or the error protection state is entered, 1 is written to this bit. The input level to the FWE pin and the error protection state can be confirmed with the FWE bit (bit 7) and the FLER bit (bit 4) in FCCS, respectively. For conditions to enter the error protection state, see section 19.6.3, Error Protection.</p> <p>0: FWE and FLER settings are normal (FWE = 1, FLER = 0)</p> <p>1: FWE = 0 or FLER = 1, and erasure cannot be performed</p>

Bit	Bit Name	Initial Value	R/W	Description
5	EE	Undefined	R/W	<p>Erase Execution Error Detect</p> <p>1 is returned to this bit when the user MAT could not be erased or when flash-memory related register settings are partially changed on returning from the user branch processing.</p> <p>If this bit is set to 1, there is a high possibility that the user MAT is partially erased. In this case, after removing the error factor, erase the user MAT.</p> <p>If FMATS is set to H'AA and the user boot MAT is selected, an error occurs when erasure is performed. In this case, both the user MAT and user boot MAT are not erased.</p> <p>Erase of the user boot MAT must be executed in boot mode or programmer mode.</p> <p>0: Erasure has ended normally 1: Erasure has ended abnormally (erasure result is not guaranteed)</p>
4	FK	Undefined	R/W	<p>Flash Key Register Error Detect</p> <p>Returns the check result of FKEY value before start of the erasing processing.</p> <p>0: FKEY setting is normal (FKEY = H'5A) 1: FKEY setting is error (FKEY = value other than H'5A)</p>
3	EB	Undefined	R/W	<p>Erase Block Select Error Detect</p> <p>Returns the check result whether the specified erase-block number is in the block range of the user MAT.</p> <p>0: Setting of erase-block number is normal 1: Setting of erase-block number is abnormal</p>
2, 1	—	Undefined	R/W	<p>Unused</p> <p>Return 0.</p>
0	SF	Undefined	R/W	<p>Success/Fail</p> <p>Indicates whether the erasing processing has ended normally or not.</p> <p>0: Erasure has ended normally (no error) 1: Erasure has ended abnormally (error occurs)</p>

19.4.4 RAM Emulation Register (RAMER)

When the realtime programming of the user MAT is emulated, RAMER sets the area of the user MAT which is overlapped with a part of the on-chip RAM. The RAM emulation must be executed in user mode or in user program mode.

For the division method of the user-MAT area, see table 19.7. In order to operate the emulation function certainly, the target MAT of the RAM emulation must not be accessed immediately after RAMER is programmed. If it is accessed, the normal access is not guaranteed.

Bit:	15	14	13	12	11	10	9	8	7	6	5	4	3	2	1	0
	-	-	-	-	-	-	-	-	-	-	-	-	RAMS	RAM[2:0]		
Initial value:	0	0	0	0	0	0	0	0	0	0	0	0	0	0	0	0
R/W:	R	R	R	R	R	R	R	R	R	R	R	R	R/W	R/W	R/W	R/W

Bit	Bit Name	Initial Value	R/W	Description
15 to 4	—	All 0	R	Reserved These bits are always read as 0. The write value should always be 0.
3	RAMS	0	R/W	RAM Select Sets whether the user MAT is emulated or not. When RAMS = 1, all blocks of the user MAT are in the programming/erasing protection state. 0: Emulation is not selected Programming/erasing protection of all user-MAT blocks is invalid 1: Emulation is selected Programming/erasing protection of all user-MAT blocks is valid
2 to 0	RAM[2:0]	000	R/W	User MAT Area Select These bits are used with bit 3 to select the user-MAT area to be overlapped with the on-chip RAM. (See table 19.7.)

Table 19.7 Overlapping of RAM Area and User MAT Area

RAM Area	Block Name	RAMS	RAM2	RAM1	RAM0
H'FFFA000 to H'FFFAFFF	RAM area (4 kbytes)	0	x	x	x
H'00000000 to H'00000FFF	EB0 (4 kbytes)	1	0	0	0
H'00001000 to H'00001FFF	EB1 (4 kbytes)	1	0	0	1
H'00002000 to H'00002FFF	EB2 (4 kbytes)	1	0	1	0
H'00003000 to H'00003FFF	EB3 (4 kbytes)	1	0	1	1
H'00004000 to H'00004FFF	EB4 (4 kbytes)	1	1	0	0
H'00005000 to H'00005FFF	EB5 (4 kbytes)	1	1	0	1
H'00006000 to H'00006FFF	EB6 (4 kbytes)	1	1	1	0
H'00007000 to H'00007FFF	EB7 (4 kbytes)	1	1	1	1

Note: x: Don't care.

19.5 On-Board Programming Mode

When the pin is set in on-board programming mode and the reset start is executed, the on-board programming state that can program/erase the on-chip flash memory is entered. On-board programming mode has three operating modes: user program mode, user boot mode, and boot mode.

For details on the pin setting for entering each mode, see table 19.1. For details on the state transition of each mode for flash memory, see figure 19.2.

19.5.1 Boot Mode

Boot mode executes programming/erasing user MAT and user boot MAT by means of the control command and program data transmitted from the host using the on-chip SCI. The tool for transmitting the control command and program data must be prepared in the host. The SCI communication mode is set to asynchronous mode. When reset start is executed after this LSI's pin is set in boot mode, the boot program in the microcomputer is initiated. After the SCI bit rate is automatically adjusted, the communication with the host is executed by means of the control command method.

The system configuration diagram in boot mode is shown in figure 19.6. For details on the pin setting in boot mode, see table 19.1. Interrupts are ignored in boot mode so do not generate them. Note that the AUD cannot be used during boot mode operation.

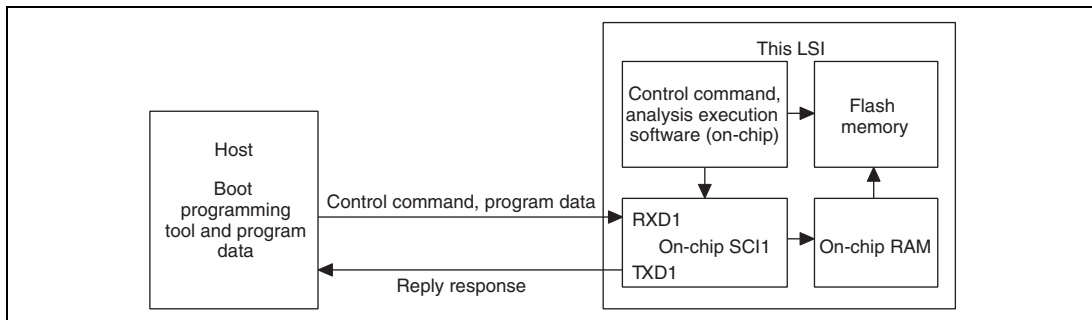

Figure 19.6 System Configuration in Boot Mode

(1) SCI Interface Setting by Host

When boot mode is initiated, this LSI measures the low period of asynchronous SCI-communication data (H'00), which is transmitted consecutively by the host. The SCI transmit/receive format is set to 8-bit data, 1 stop bit, and no parity. This LSI calculates the bit rate of transmission by the host by means of the measured low period and transmits the bit adjustment end sign (1 byte of H'00) to the host. The host must confirm that this bit adjustment end sign (H'00) has been received normally and transmits 1 byte of H'55 to this LSI. When reception is not executed normally, boot mode is initiated again (reset) and the operation described above must be executed. The bit rate between the host and this LSI is not matched because of the bit rate of transmission by the host and system clock frequency of this LSI. To operate the SCI normally, the transfer bit rate of the host must be set to 9,600 bps or 19,200 bps.

The system clock frequency which can automatically adjust the transfer bit rate of the host and the bit rate of this LSI is shown in table 19.8. Boot mode must be initiated in the range of this system clock. Note that the internal clock division ratio of $\times 1/3$ is not supported in boot mode.

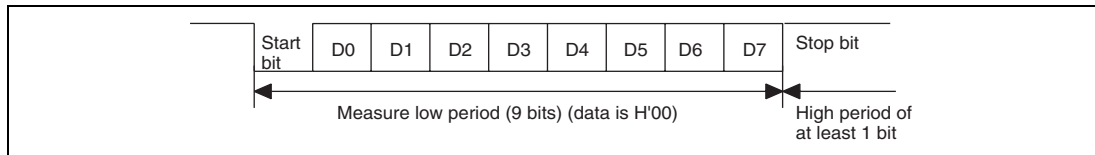

Figure 19.7 Automatic Adjustment Operation of SCI Bit Rate

Table 19.8 Peripheral Clock (P ϕ) Frequency that Can Automatically Adjust Bit Rate of This LSI

Host Bit Rate	Peripheral Clock (P ϕ) Frequency Which Can Automatically Adjust LSI's Bit Rate
9,600 bps	10 to 40 MHz
19,200 bps	10 to 40 MHz

Note: The internal clock division ratio of $\times 1/3$ is not supported in boot mode.

(2) State Transition Diagram

Figure 19.8 gives an overview of the state transitions after the chip has been started up in boot mode. For details on boot mode, see section 19.9.1, Specifications of the Standard Serial Communications Interface in Boot Mode.

1. Bit-rate matching

After the chip has been started up in boot mode, bit-rate matching between the SCI and the host proceeds.

2. Waiting for inquiry and selection commands

The chip sends the requested information to the host in response to inquiries regarding the size and configuration of the user MAT, start addresses of the MATs, information on supported devices, etc.

3. Automatic erasure of the entire user MAT and user boot MAT

After all necessary inquiries and selections have been made and the command for transition to the programming/erasure state is sent by the host, the entire user MAT and user boot MAT are automatically erased.

4. Waiting for programming/erasure command

- On receiving the programming selection command, the chip waits for data to be programmed. To program data, the host transmits the programming command code followed by the address where programming should start and the data to be programmed. This is repeated as required while the chip is in the programming-selected state. To terminate programming, H'FFFFFFFF should be transmitted as the first address of the area for programming. This makes the chip return to the programming/erasure command waiting state from the programming data waiting state.
- On receiving the erasure select command, the chip waits for the block number of a block to be erased. To erase a block, the host transmits the erasure command code followed by the number of the block to be erased. This is repeated as required while the chip is in the erasure-selected state. To terminate erasure, H'FF should be transmitted as the block number. This makes the chip return to the programming/erasure command waiting state from the erasure block number waiting state. Erasure should only be executed when a specific block is to be reprogrammed without executing a reset-start of the chip after the flash memory has been programmed in boot mode. If all desired programming is done in a single operation, such erasure processing is not necessary because all blocks are erased before the chip enters the programming/erasure/other command waiting state.
- In addition to the programming and erasure commands, commands for sum checking and blank checking (checking for erasure) of the user MAT and user boot MAT, reading data from the user MAT/user boot MAT, and acquiring current state information are provided.

Note that the command for reading from the user MAT/user boot MAT can only read data that has been programmed after automatic erasure of the entire user MAT and user boot MAT.

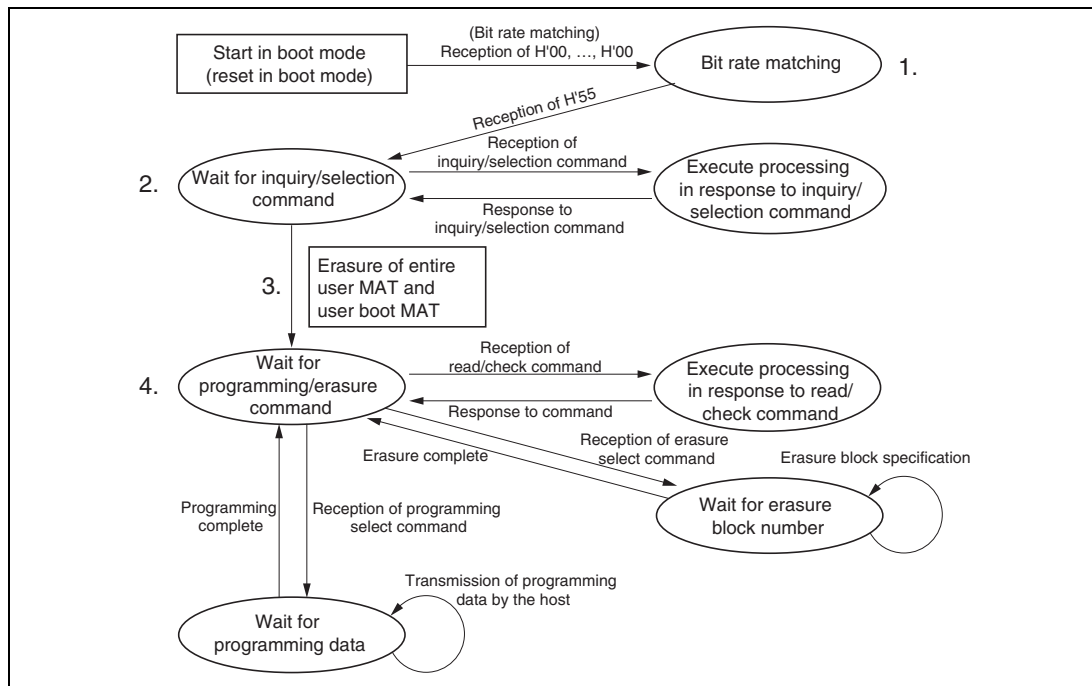

Figure 19.8 State Transitions in Boot Mode

19.5.2 User Program Mode

The user MAT can be programmed/erased in user program mode. (The user boot MAT cannot be programmed/erased.)

Programming/erasing is executed by downloading the program in the microcomputer.

The overview flow is shown in figure 19.9.

High voltage is applied to internal flash memory during the programming/erasing processing. Therefore, transition to reset must not be executed. Doing so may cause damage or destroy flash memory. If reset is executed accidentally, the reset signal must be released after the reset input period, which is longer than the normal 100 μ s.

For details on the programming procedure, see the description in section 19.5.2 (2), Programming Procedure in User Program Mode. For details on the erasing procedure, see the description in section 19.5.2 (3), Erasing Procedure in User Program Mode.

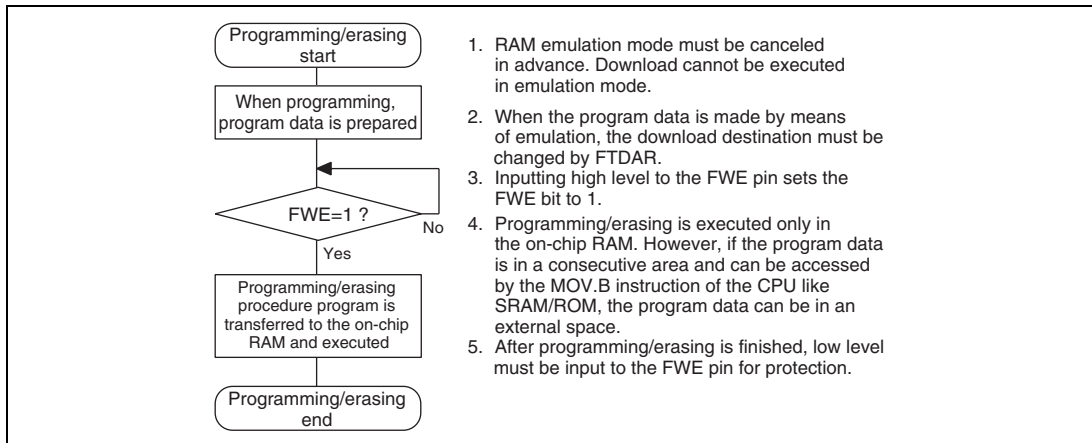

Figure 19.9 Programming/Erasing Overview Flow

(1) On-Chip RAM Address Map when Programming/Erasing is Executed

Parts of the procedure program that are made by the user, like download request, programming/erasing procedure, and decision of the result, must be executed in the on-chip RAM. All of the on-chip program that is to be downloaded is in on-chip RAM. Note that on-chip RAM must be controlled so that these parts do not overlap.

Figure 19.10 shows the program area to be downloaded.

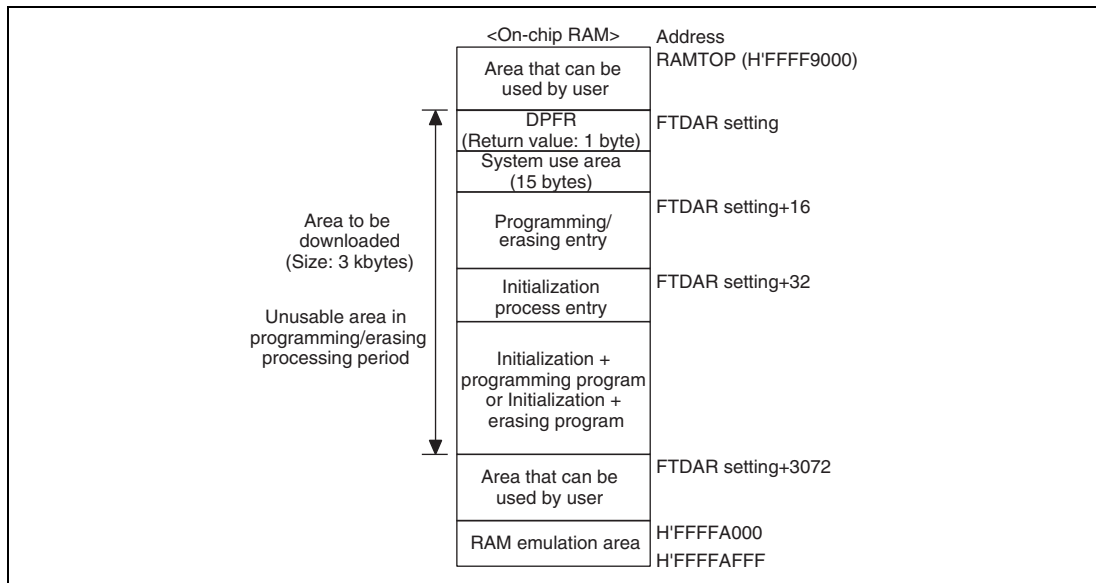

Figure 19.10 RAM Map after Download

(2) Programming Procedure in User Program Mode

The procedures for download, initialization, and programming are shown in figure 19.11.

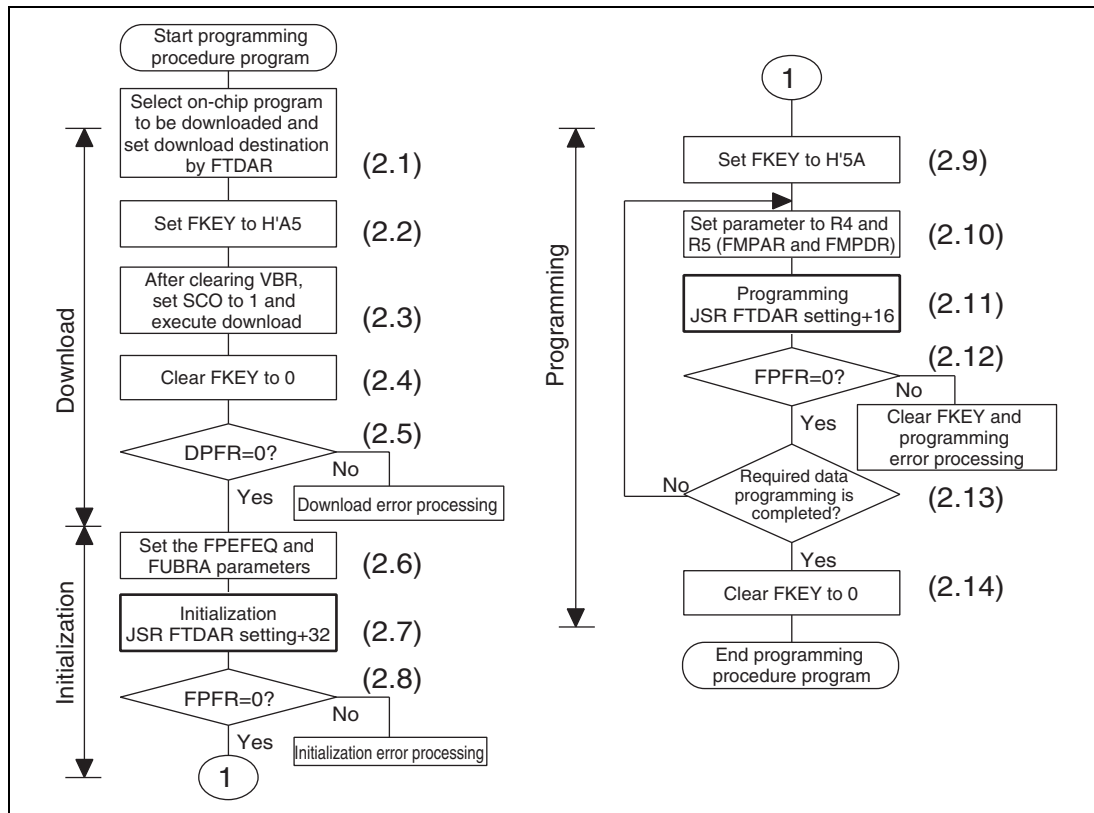

Figure 19.11 Programming Procedure

The details of the programming procedure are described below. The procedure program must be executed in an area other than the flash memory to be programmed. Especially the part where the SCO bit in FCCS is set to 1 for downloading must be executed in the on-chip RAM. Specify 1/4 (initial value) as the frequency division ratios of an internal clock ($I\phi$), a bus clock ($B\phi$), and a peripheral clock ($P\phi$) through the frequency control register (FRQCR).

After the programming/erasing program has been downloaded and the SCO bit is cleared to 0, the setting of the frequency control register (FRQCR) can be changed to the desired value.

The area that can be executed in the steps of the user procedure program (on-chip RAM, user MAT, and external space) is shown in section 19.9.2, Areas for Storage of the Procedural Program and Data for Programming.

The following description assumes the area to be programmed on the user MAT is erased and program data is prepared in the consecutive area. When erasing has not been executed, carry out erasing before writing.

128-byte programming is performed in one program processing. When more than 128-byte programming is performed, programming destination address/program data parameter is updated in 128-byte units and programming is repeated.

When less than 128-byte programming is performed, data must total 128 bytes by adding the invalid data. If the invalid data to be added is H'FF, the program processing period can be shortened.

(2.1) Select the on-chip program to be downloaded

When the PPVS bit of FPCS is set to 1, the programming program is selected.

Several programming/erasing programs cannot be selected at one time. If several programs are set, download is not performed and a download error is returned to the source select error detect (SS) bit in the DPFR parameter.

Specify the start address of the download destination by FTDAR.

(2.2) Write H'A5 in FKEY

If H'A5 is not written to FKEY for protection, 1 cannot be written to the SCO bit for a download request.

(2.3) VBR is set to 0 and 1 is written to the SCO bit of FCCS, and then download is executed.

VBR must always be set to H'84000000 before setting the SCO bit to 1.

To write 1 to the SCO bit, the following conditions must be satisfied.

- RAM emulation mode is canceled.
- H'A5 is written to FKEY.
- The SCO bit writing is executed in the on-chip RAM.

When the SCO bit is set to 1, download is started automatically. When execution returns to the user procedure program, the SCO bit is cleared to 0. Therefore, the SCO bit cannot be confirmed to be 1 in the user procedure program.

The download result can be confirmed only by the return value of the DPFR parameter. Before the SCO bit is set to 1, incorrect decision must be prevented by setting the DPFR parameter, that is one byte of the start address of the on-chip RAM area specified by FTDAR, to a value other than the return value (H'FF).

When download is executed, particular interrupt processing, which is accompanied by the bank switch as described below, is performed as an internal microcomputer processing, so VBR need to be set to H'84000000. Four NOP instructions are executed immediately after the instructions that set the SCO bit to 1.

- The user MAT space is switched to the on-chip program storage area.

- After the selection condition of the download program and the address set in FTDAR are checked, the transfer processing is executed starting to the on-chip RAM address specified by FTDAR.
- The SCO bits in FCCS, FPCS, and FECS are cleared to 0.
- The return value is set to the DPFR parameter.
- After the on-chip program storage area is returned to the user MAT space, execution returns to the user procedure program.

After download is completed and the user procedure program is running, the VBR setting can be changed.

The notes on download are as follows.

In the download processing, the values of the general registers of the CPU are retained.

During the download processing, interrupts must not be generated. For details on the relationship between download and interrupts, see section 19.8.2, Interrupts during Programming/Erasing.

Since a stack area of maximum 128 bytes is used, an area of at least 128 bytes must be saved before setting the SCO bit to 1.

If flash memory is accessed by the DTC during downloading, operation cannot be guaranteed. Therefore, access by the DTC must not be executed.

(2.4) FKEY is cleared to H'00 for protection.

(2.5) The value of the DPFR parameter must be checked to confirm the download result.

A recommended procedure for confirming the download result is shown below.

- Check the value of the DPFR parameter (one byte of start address of the download destination specified by FTDAR). If the value is H'00, download has been performed normally. If the value is not H'00, the source that caused download to fail can be investigated by the description below.
- If the value of the DPFR parameter is the same as before downloading (e.g. H'FF), the address setting of the download destination in FTDAR may be abnormal. In this case, confirm the setting of the TDER bit (bit 7) in FTDAR.
- If the value of the DPFR parameter is different from before downloading, check the SS bit (bit 2) and the FK bit (bit 1) in the DPFR parameter to ensure that the download program selection and FKEY register setting were normal, respectively.

(2.6) The operating frequency is set to the FPEFEQ parameter and the user branch destination is set to the FUBRA parameter for initialization.

- The current frequency of the CPU clock is set to the FPEFEQ parameter (general register R4). For the settable range of the FPEFEQ parameter, see section 24.3.1, Clock Timing.
When the frequency is set out of this range, an error is returned to the FPFR parameter of the initialization program and initialization is not performed. For details on the frequency setting, see the description in section 19.4.3 (2.1), Flash programming/erasing frequency parameter (FPEFEQ: general register R4 of CPU).
- The start address in the user branch destination is set to the (FUBRA: CPU general register R5) parameter.
When the user branch processing is not required, 0 must be set to FUBRA.
When the user branch is executed, the branch destination is executed in flash memory other than the one that is to be programmed. The area of the on-chip program that is downloaded cannot be set.
The program processing must be returned from the user branch processing by the RTS instruction.
See the description in section 19.4.3 (2.2), Flash user branch address setting parameter (FUBRA: general register R5 of CPU).

(2.7) Initialization

When a programming program is downloaded, the initialization program is also downloaded to on-chip RAM. There is an entry point of the initialization program in the area from (download start address set by FTDAR) + 32 bytes. The subroutine is called and initialization is executed by using the following steps.

```
MOV.L #DLTOP+32,R1      ; Set entry address to R1
JSR  @R1                ; Call initialization routine
NOP
```

- The general registers other than R0 are saved in the initialization program.
- R0 is a return value of the FPFR parameter.
- Since the stack area is used in the initialization program, a stack area of maximum 128 bytes must be reserved in RAM.
- Interrupts can be accepted during the execution of the initialization program. However, the program storage area and stack area in on-chip RAM and register values must not be destroyed.

(2.8) The return value of the initialization program, FPFR (general register R0) is checked.

(2.9) FKEY must be set to H'5A and the user MAT must be prepared for programming.

(2.10) The parameter which is required for programming is set.

The start address of the programming destination of the user MAT (FMPAR) is set to general register R5. The start address of the program data storage area (FMPDR) is set to general register R4.

- FMPAR setting

FMPAR specifies the programming destination start address. When an address other than one in the user MAT area is specified, even if the programming program is executed, programming is not executed and an error is returned to the return value parameter FPFR. Since the unit is 128 bytes, the lower eight bits (MOA7 to MOA0) must be in the 128-byte boundary of H'00 or H'80.

- FMPDR setting

If the storage destination of the program data is flash memory, even when the program execution routine is executed, programming is not executed and an error is returned to the FPFR parameter. In this case, the program data must be transferred to on-chip RAM and then programming must be executed.

(2.11) Programming

There is an entry point of the programming program in the area from (download start address set by FTDAR) + 16 bytes of on-chip RAM. The subroutine is called and programming is executed by using the following steps.

MOV.L	#DLTOP+16,R1	; Set entry address to R1
JSR	@R1	; Call programming routine
NOP		

— The general registers other than R0 are saved in the programming program.

— R0 is a return value of the FPFR parameter.

— Since the stack area is used in the programming program, a stack area of maximum 128 bytes must be reserved in RAM.

(2.12) The return value in the programming program, FPFR (general register R0) is checked.

(2.13) Determine whether programming of the necessary data has finished.

If more than 128 bytes of data are to be programmed, specify FMPAR and FMPDR in 128-byte units, and repeat steps (2.10) to (2.13). Increment the programming destination address by 128 bytes and update the programming data pointer correctly. If an address which has already been programmed is written to again, not only will a programming error occur, but also flash memory will be damaged.

(2.14) After programming finishes, clear FKEY and specify software protection.

If this LSI is restarted by a power-on reset immediately after user MAT programming has finished, secure a reset period (period of $\overline{\text{RES}} = 0$) that is at least as long as the normal 100 μs .

(3) Erasing Procedure in User Program Mode

The procedures for download, initialization, and erasing are shown in figure 19.12.

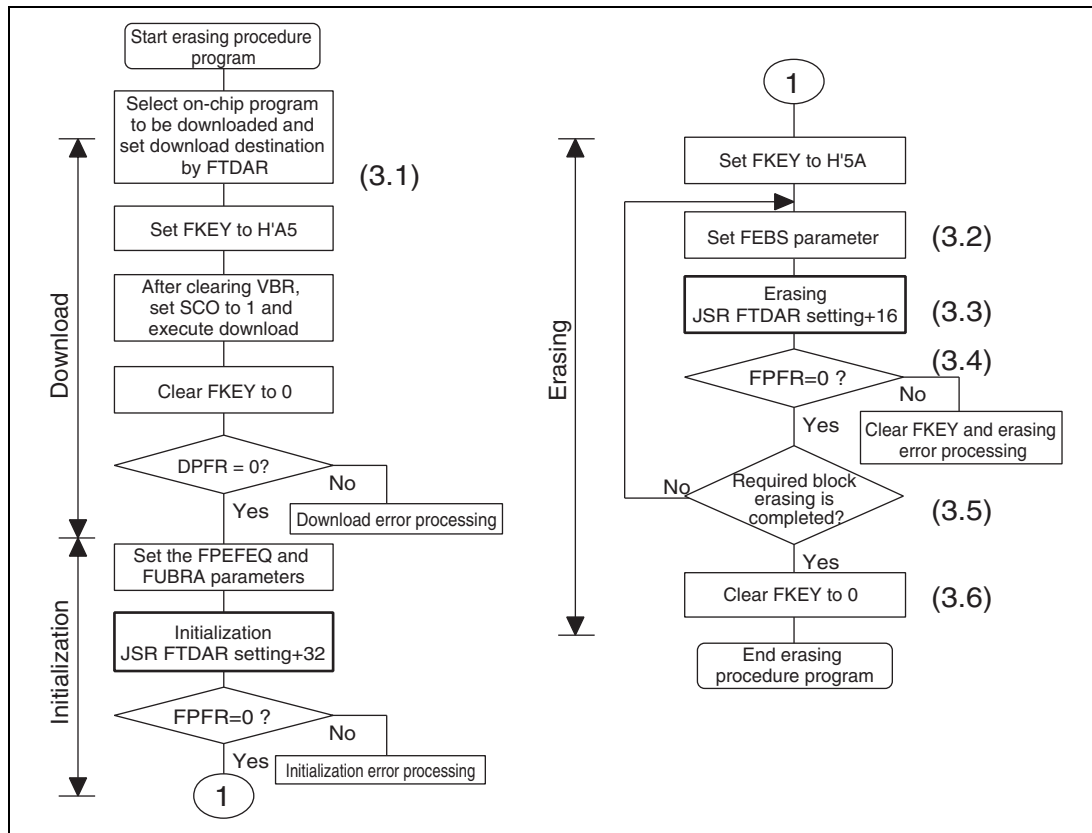

Figure 19.12 Erasing Procedure

The details of the erasing procedure are described below. The procedure program must be executed in an area other than the user MAT to be erased. Especially the part where the SCO bit in FCCS is set to 1 for downloading must be executed in on-chip RAM. Specify 1/4 (initial value) as the frequency division ratios of an internal clock (If), a bus clock (Bf), and a peripheral clock (Pf) through the frequency control register (FRQCR).

After the programming/erasing program has been downloaded and the SCO bit is cleared to 0, the setting of the frequency control register (FRQCR) can be changed to the desired value.

The area that can be executed in the steps of the user procedure program (on-chip RAM, user MAT, and external space) is shown in section 19.9.2, Areas for Storage of the Procedural Program and Data for Programming.

For the downloaded on-chip program area, see the RAM map for programming/erasing in figure 19.10.

A single divided block is erased by one erasing processing. For block divisions, see figure 19.4. To erase two or more blocks, update the erase block number and perform the erasing processing for each block.

(3.1) Select the on-chip program to be downloaded

Set the EPVB bit in FECS to 1.

Several programming/erasing programs cannot be selected at one time. If several programs are set, download is not performed and a download error is returned to the source select error detect (SS) bit in the DPFR parameter.

Specify the start address of the download destination by FTDAR.

The procedures to be carried out after setting FKEY, e.g. download and initialization, are the same as those in the programming procedure. For details, see the description in section 19.5.2 (2), Programming Procedure in User Program Mode.

(3.2) Set the FEBS parameter necessary for erasure

Set the erase block number of the user MAT in the flash erase block select parameter (FEBS: general register R4). If a value other than an erase block number of the user MAT is set, no block is erased even though the erasing program is executed, and an error is returned to the return value parameter FPFR.

(3.3) Erasure

Similar to as in programming, there is an entry point of the erasing program in the area from (download start address set by FTDAR) + 16 bytes of on-chip RAM. The subroutine is called and erasing is executed by using the following steps.

MOV.L	#DLTOP+16,R1	; Set entry address to R1
JSR	@R1	; Call erasing routine
NOP		

— The general registers other than R0 are saved in the erasing program.

— R0 is a return value of the FPFR parameter.

— Since the stack area is used in the erasing program, a stack area of maximum 128 bytes must be reserved in RAM.

(3.4) The return value in the erasing program, FPFR (general register R0) is checked.

(3.5) Determine whether erasure of the necessary blocks has finished.

If more than one block is to be erased, update the FEBS parameter and repeat steps (3.2) to (3.5). Blocks that have already been erased can be erased again.

(3.6) After erasure finishes, clear FKEY and specify software protection.

If this LSI is restarted by a power-on reset immediately after user MAT erasing has finished, secure a reset period (period of $\overline{\text{RES}} = 0$) that is at least as long as the normal 100 μs .

19.5.3 User Boot Mode

This LSI has user boot mode which is initiated with different mode pin settings than those in user program mode or boot mode. User boot mode is a user-arbitrary boot mode, unlike boot mode that uses the on-chip SCI.

Only the user MAT can be programmed/erased in user boot mode. Programming/erasing of the user boot MAT is only enabled in boot mode or programmer mode.

(1) User Boot Mode Initiation

For the mode pin settings to start up user boot mode, see table 19.1.

When the reset start is executed in user boot mode, the check routine for flash-memory related registers runs. The RAM area about 1.2 kbytes from H'FFFF9800 and 4 bytes from H'FFFFAFFC (a stack area) is used by the routine. While the check routine is running, NMI and all other interrupts cannot be accepted. Neither can the AUD be used in this period. This period is 100 μs while operating at an internal frequency of 40 MHz.

Next, processing starts from the execution start address of the reset vector in the user boot MAT. At this point, H'AA is set to the flash MAT select register (FMATS) because the execution MAT is the user boot MAT.

(2) User MAT Programming in User Boot Mode

For programming the user MAT in user boot mode, additional processings made by setting FMATS are required: switching from user-boot-MAT selection state to user-MAT selection state, and switching back to user-boot-MAT selection state after programming completes.

Figure 19.13 shows the procedure for programming the user MAT in user boot mode.

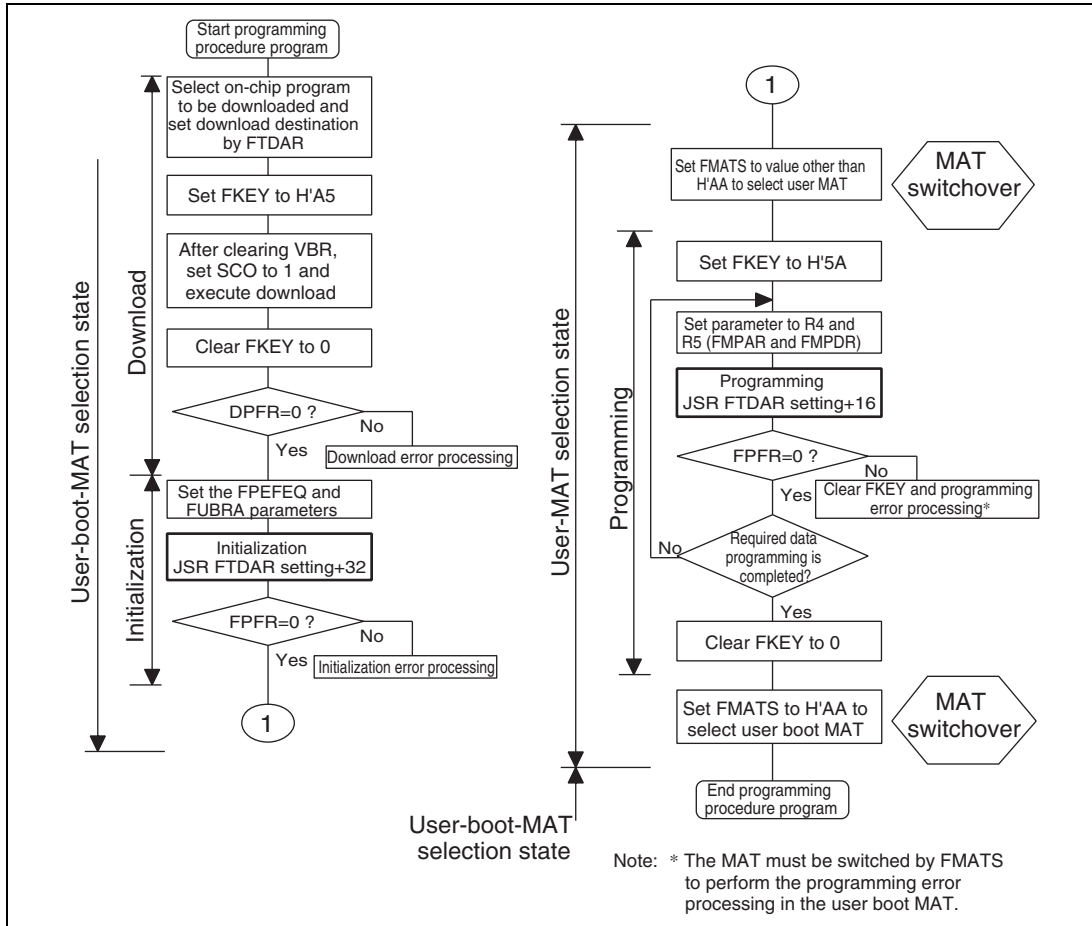

Figure 19.13 Procedure for Programming User MAT in User Boot Mode

The difference between the programming procedures in user program mode and user boot mode is whether the MAT is switched or not as shown in figure 19.13.

In user boot mode, the user boot MAT can be seen in the flash memory space with the user MAT hidden in the background. The user MAT and user boot MAT are switched only while the user MAT is being programmed. Because the user boot MAT is hidden while the user MAT is being programmed, the procedure program must be located in an area other than flash memory. After programming finishes, switch the MATs again to return to the first state.

MAT switchover is enabled by writing a specific value to FMATS. However note that while the MATs are being switched, the LSI is in an unstable state, e.g. access to a MAT is not allowed until MAT switching is completely finished, and if an interrupt occurs, from which MAT the interrupt vector is read from is undetermined. Perform MAT switching in accordance with the description in section 19.8.1, Switching between User MAT and User Boot MAT.

Except for MAT switching, the programming procedure is the same as that in user program mode.

The area that can be executed in the steps of the user procedure program (on-chip RAM, user MAT, and external space) is shown in section 19.9.2, Areas for Storage of the Procedural Program and Data for Programming.

(3) User MAT Erasing in User Boot Mode

For erasing the user MAT in user boot mode, additional processings made by setting FMATS are required: switching from user-boot-MAT selection state to user-MAT selection state, and switching back to user-boot-MAT selection state after erasing completes.

Figure 19.14 shows the procedure for erasing the user MAT in user boot mode.

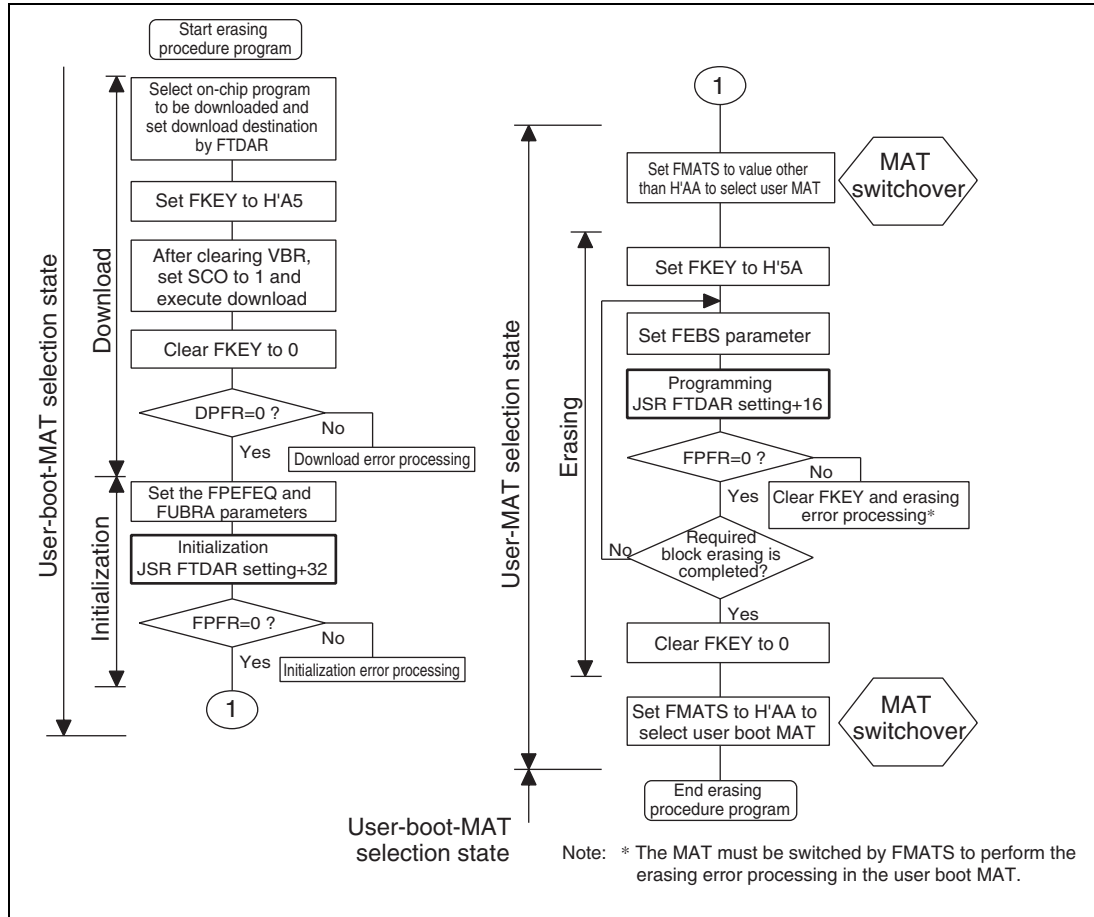

Figure 19.14 Procedure for Erasing User MAT in User Boot Mode

The difference between the erasing procedures in user program mode and user boot mode depends on whether the MAT is switched or not as shown in figure 19.14.

MAT switching is enabled by writing a specific value to FMATS. However note that while the MATs are being switched, the LSI is in an unstable state, e.g. access to a MAT is not allowed until MAT switching is completed finished, and if an interrupt occurs, from which MAT the interrupt vector is read from is undetermined. Perform MAT switching in accordance with the description in section 19.8.1, Switching between User MAT and User Boot MAT.

Except for MAT switching, the erasing procedure is the same as that in user program mode.

The area that can be executed in the steps of the user procedure program (on-chip RAM, user MAT, and external space) is shown in section 19.9.2, Areas for Storage of the Procedural Program and Data for Programming.

19.6 Protection

There are three kinds of flash memory program/erase protection: hardware, software, and error protection.

19.6.1 Hardware Protection

Programming and erasing of flash memory is forcibly disabled or suspended by hardware protection. In this state, the downloading of an on-chip program and initialization of the flash memory are possible. However, an activated program for programming or erasure cannot program or erase locations in a user MAT, and the error in programming/erasing is reported in the FPFPR parameter.

Table 19.9 Hardware Protection

Item	Description	Function to be Protected	
		Download	Programming/ Erasure
FWE-pin protection	The input of a low-level signal on the FWE pin clears the FWE bit of FCCS and the LSI enters a programming/erasing-protected state.	—	√
Reset/standby protection	<ul style="list-style-type: none"> A power-on reset (including a power-on reset by the WDT) and entry to standby mode initializes the programming/erasing interface registers and the LSI enters a programming/erasing-protected state. Resetting by means of the $\overline{\text{RES}}$ pin after power is initially supplied will not make the LSI enter the reset state unless the $\overline{\text{RES}}$ pin is held low until oscillation has stabilized. In the case of a reset during operation, hold the $\overline{\text{RES}}$ pin low for the $\overline{\text{RES}}$ pulse width that is specified in the section on AC characteristics. If the LSI is reset during programming or erasure, data in the flash memory is not guaranteed. In this case, execute erasure and then execute programming again. 	√	√

19.6.2 Software Protection

Software protection is set up in any of three ways: by disabling the downloading of on-chip programs for programming and erasing, by means of a key code, and by the RAM emulation register (RAMER).

Table 19.10 Software Protection

Item	Description	Function to be Protected	
		Download	Programming/ Erasure
Protection by the SCO bit	Clearing the SCO bit in FCCS disables downloading of the programming/erasing program, thus making the LSI enter a programming/erasing-protected state.	√	√
Protection by FKEY	Downloading and programming/erasing are disabled unless the required key code is written in FKEY. Different key codes are used for downloading and for programming/erasing.	√	√
Emulation protection	Setting the RAMS bit in RAMER to 1 makes the LSI enter a programming/erasing-protected state.	√	√

19.6.3 Error Protection

Error protection is a mechanism for aborting programming or erasure when an error occurs, in the form of the microcomputer getting out of control during programming/erasing of the flash memory or operations that are not in accordance with the established procedures for programming/erasing. Aborting programming or erasure in such cases prevents damage to the flash memory due to excessive programming or erasing.

If the microcomputer malfunctions during programming/erasing of the flash memory, the FLER bit in FCCS is set to 1 and the LSI enters the error protection state, thus aborting programming or erasure.

The FLER bit is set to 1 in the following conditions:

- When the relevant bank area of flash memory is read during programming/erasing (including a vector read or an instruction fetch)
- When a SLEEP instruction (including software standby mode) is executed during programming/erasing

Error protection is cancelled (FLER bit is cleared) only by a power-on reset.

Note that the reset signal should only be released after providing a reset input over a period longer than the normal 100 μ s. Since high voltages are applied during programming/erasing of the flash memory, some voltage may still remain even after the error protection state has been entered. For this reason, it is necessary to reduce the risk of damage to the flash memory by extending the reset period so that the charge is released.

The state-transition diagram in figure 19.15 shows transitions to and from the error protection state.

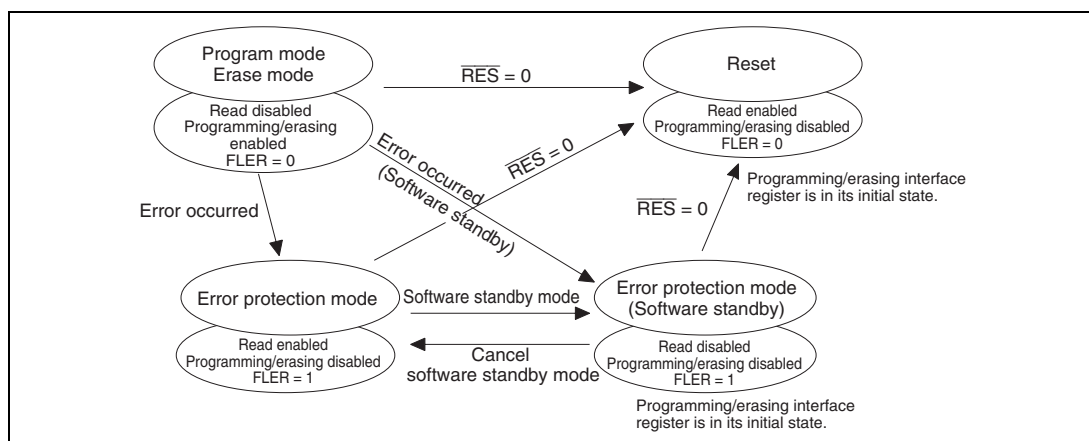

Figure 19.15 Transitions to and from Error Protection State

19.7 Flash Memory Emulation in RAM

To provide real-time emulation in RAM of data that is to be written to the flash memory, a part of the RAM can be overlaid on an area of flash memory (user MAT) that has been specified by the RAM emulation register (RAMER). After the RAMER setting is made, the RAM is accessible in both the user MAT area and as the RAM area that has been overlaid on the user MAT area. Such emulation is possible in user mode and user program mode.

Figure 19.16 shows an example of the emulation of realtime programming of the user MAT area.

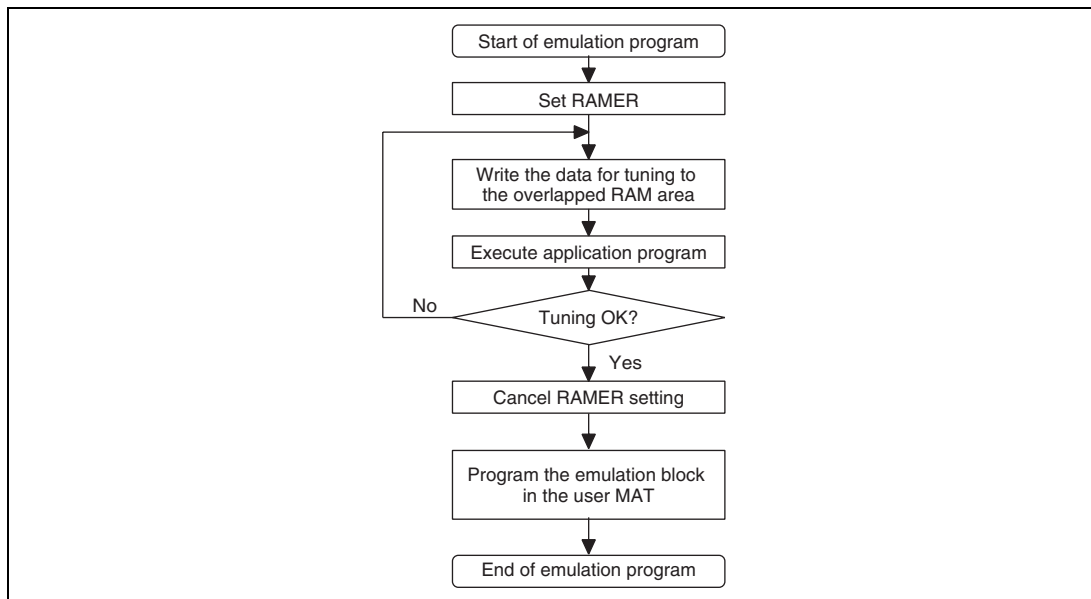

Figure 19.16 Emulation of Flash Memory in RAM

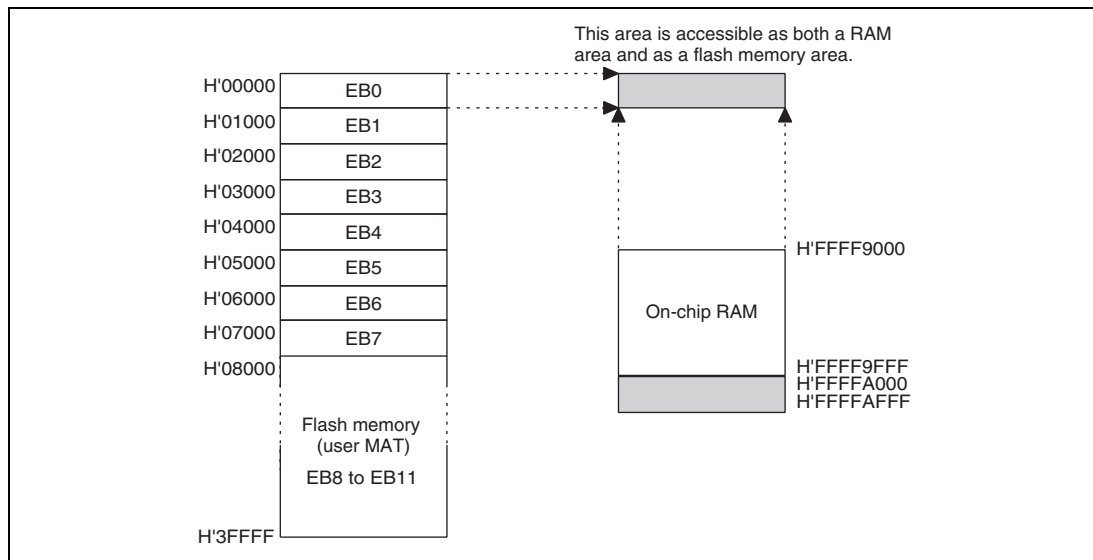

Figure 19.17 Example of Overlapped RAM Operation

Figure 19.17 shows an example of an overlap on block area EB0 of the flash memory.

Emulation is possible for a single area selected from among the eight areas, from EB0 to EB7, of the user MAT. The area is selected by the setting of the RAM2 to RAM0 bits in RAMER.

1. To overlap a part of the RAM on area EB0, to allow realtime programming of the data for this area, set the RAMS bit in RAMER to 1, and each of the RAM2 to RAM0 bits to 0.
2. Realtime programming is carried out using the overlaid area of RAM.

In programming or erasing the user MAT, it is necessary to run a program that implements a series of procedural steps, including the downloading of an on-chip program. In this process, set the download area with FTDAR so that the overlaid RAM area and the area where the on-chip program is to be downloaded do not overlap.

Figure 19.18 shows an example of programming data that has been emulated to the EB0 area in the user MAT.

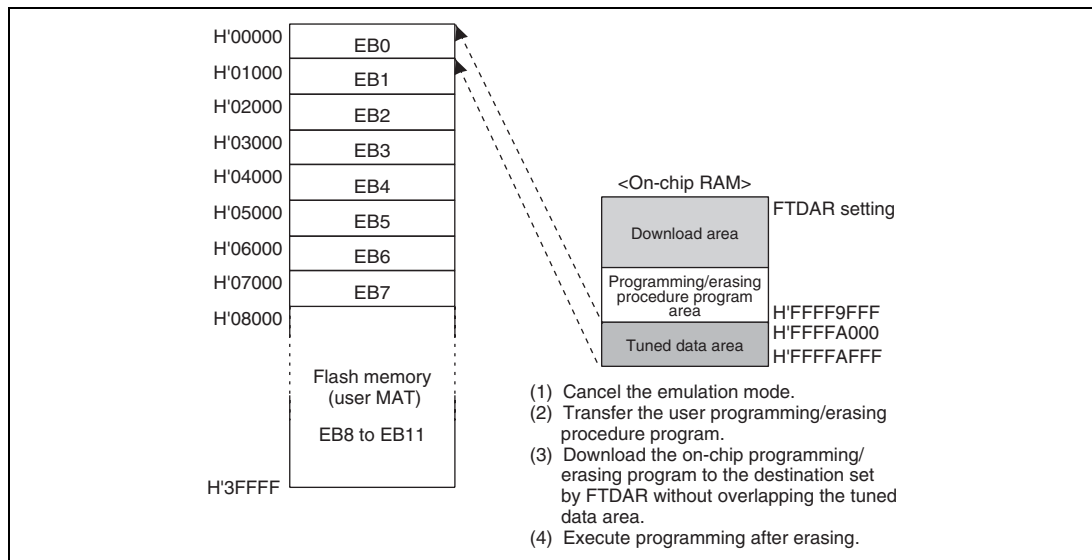

Figure 19.18 Programming of Tuned Data

1. After the data to be programmed has fixed values, clear the RAMS bit to 0 to cancel the overlap of RAM. Emulation mode is canceled and emulation protection is also cleared.
2. Transfer the user programming/erasing procedure program to RAM.
3. Run the programming/erasing procedure program in RAM and download the on-chip programming/erasing program.
Specify the download start address with FTDAR so that the tuned data area does not overlap with the download area.
4. When the EB0 area of the user MAT has not been erased, erasing must be performed before programming. Set the parameters FMPAR and FMPDR so that the tuned data is designated, and execute programming.

Note: Setting the RAMS bit to 1 puts all the blocks in flash memory in the programming/erasing-protected state regardless of the values of the RAM2 to RAM0 bits (emulation protection). Clear the RAMS bit to 0 before actual programming or erasure. Though RAM emulation can also be carried out with the user boot MAT selected, the user boot MAT can be erased or programmed only in boot mode or programmer mode.

19.8 Usage Notes

19.8.1 Switching between User MAT and User Boot MAT

It is possible to switch between the user MAT and user boot MAT. However, the following procedure is required because these MATs are allocated to address 0.

(Switching to the user boot MAT disables programming and erasing. Programming of the user boot MAT must take place in boot mode or programmer mode.)

1. MAT switching by FMATS should always be executed from the on-chip RAM. The SH microcomputer prefetches execution instructions. Therefore, a switchover during program execution in the user MAT causes an instruction code in the user MAT to be prefetched or an instruction in the newly selected user boot MAT to be prefetched, thus resulting in unstable operation.
2. To ensure that the MAT that has been switched to is accessible, execute four NOP instructions in on-chip RAM immediately after writing to FMATS of on-chip RAM (this prevents access to the flash memory during MAT switching).
3. If an interrupt occurs during switching, there is no guarantee of which memory MAT is being accessed.
Always mask the maskable interrupts before switching MATs. In addition, configuring the system so that NMI interrupts do not occur during MAT switching is recommended.
4. After the MATs have been switched, take care because the interrupt vector table will also have been switched.
If the same interrupt processings are to be executed before and after MAT switching or interrupt requests cannot be disabled, transfer the interrupt processing routine to on-chip RAM, and use the VBR setting to place the interrupt vector table in on chip RAM. In this case, make sure the VBR setting change does not conflict with the interrupt occurrence.
5. Memory sizes of the user MAT and user boot MAT are different. When accessing the user boot MAT, do not access addresses exceeding the 12-kbyte memory space. If access goes beyond the 12-kbyte space, the values read are undefined.

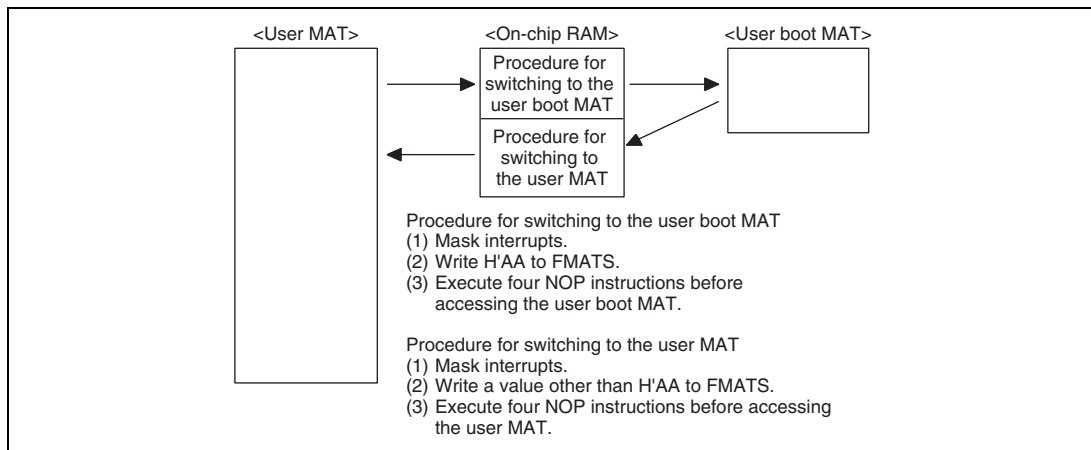

Figure 19.19 Switching between User MAT and User Boot MAT

19.8.2 Interrupts during Programming/Erasing

(1) Download of On-Chip Program

(1.1) VBR setting change

Before downloading the on-chip program, VBR must be set to H'84000000. If VBR is set to a value other than H'84000000, the interrupt vector table is placed in the user MAT (FMATS is not H'AA) or the user boot MAT (FMATS is H'AA) on setting H'84000000 to VBR.

When VBR setting change conflicts with interrupt occurrence, whether the vector table before or after VBR is changed is referenced may cause an error.

Therefore, for cases where VBR setting change may conflict with interrupt occurrence, prepare a vector table to be referenced when VBR is H'00000000 (initial value) at the start of the user MAT or user boot MAT.

(1.2) SCO download request and interrupt request

Download of the on-chip programming/erasing program that is initiated by setting the SCO bit in FCCS to 1 generates a particular interrupt processing accompanied by MAT switchover.

Operation when the SCO download request and interrupt request conflicts is described below.

1. Contention between SCO download request and interrupt request

Figure 19.20 shows the timing of contention between execution of the instruction that sets the SCO bit in FCCS to 1 and interrupt acceptance.

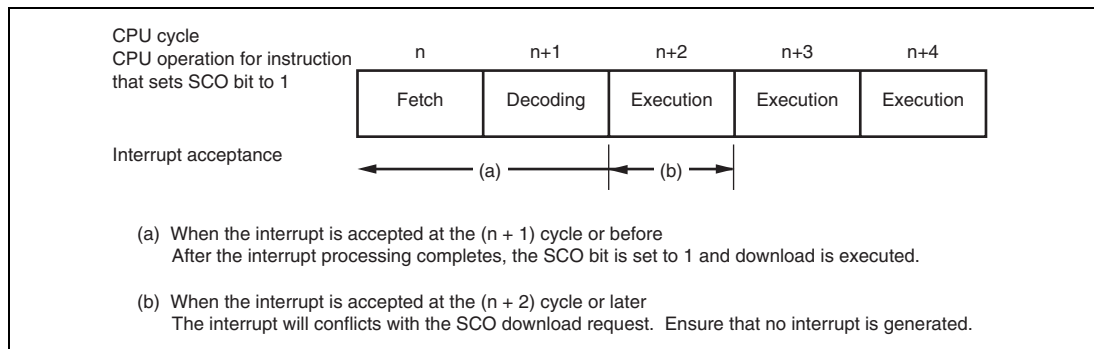

Figure 19.20 Timing of Contention between SCO Download Request and Interrupt Request

2. Generation of interrupt requests during downloading

Ensure that interrupts are not generated during downloading that is initiated by the SCO bit.

(2) Interrupts during programming/erasing

Though an interrupt processing can be executed at realtime during programming/erasing of the downloaded on-chip program, the following limitations and notes are applied.

1. When flash memory is being programmed or erased, both the user MAT and user boot MAT cannot be accessed. Prepare the interrupt vector table and interrupt processing routine in on-chip RAM or external memory. Make sure the flash memory being programmed or erased is not accessed by the interrupt processing routine. If flash memory is read, the read values are not guaranteed. If the relevant bank in flash memory that is being programmed or erased is accessed, the error protection state is entered, and programming or erasing is aborted. If a bank other than the relevant bank is accessed, the error protection state is not entered but the read values are not guaranteed.
2. Do not rewrite the program data specified by the FMPDR parameter. If new program data is to be provided by the interrupt processing, temporarily save the new program data in another area. After confirming the completion of programming, save the new program data in the area specified by FMPDR or change the setting in FMPDR to indicate the other area in which the new program data was temporarily saved.
3. Make sure the interrupt processing routine does not rewrite the contents of the flash-memory related registers or data in the downloaded on-chip program area. During the interrupt processing, do not simultaneously perform RAM emulation, download of the on-chip program by an SCO request, or programming/erasing.
4. At the beginning of the interrupt processing routine, save the CPU register contents. Before returning from the interrupt processing, write the saved contents in the CPU registers again.
5. When a transition is made to sleep mode or software standby mode in the interrupt processing routine, the error protection state is entered and programming/erasing is aborted.

If a transition is made to the reset state, the reset signal should only be released after providing a reset input over a period longer than the normal 100 μ s to reduce the damage to flash memory.

19.8.3 Other Notes

1. Download time of on-chip program

The programming program that includes the initialization routine and the erasing program that includes the initialization routine are each 3 kbytes or less. Accordingly, when the CPU clock frequency is 20 MHz, the download for each program takes approximately 10 ms at maximum.

2. User branch processing intervals

The intervals for executing the user branch processing differs in programming and erasing. The processing phase also differs. Table 19.11 lists the maximum intervals for initiating the user branch processing when the CPU clock frequency is 80 MHz.

Table 19.11 Initiation Intervals of User Branch Processing

Processing Name	Maximum Interval
Programming	Approximately 2 ms
Erasing	Approximately 15 ms

However, when operation is done with CPU clock of 80 MHz, maximum values of the time until first user branch processing are as shown in table 19.12.

Table 19.12 Initial User Branch Processing Time

Processing Name	Max.
Programming	Approximately 2 ms
Erasing	Approximately 15 ms

3. Write to flash-memory related registers by DTC

While an instruction in on-chip RAM is being executed, the DTC can write to the SCO bit in FCCS that is used for a download request or FMATS that is used for MAT switching. Make sure that these registers are not accidentally written to, otherwise an on-chip program may be downloaded and destroy RAM or a MAT switchover may occur and the CPU get out of control.

4. State in which interrupts are ignored

In the following modes or period, interrupt requests are ignored; they are not executed and the interrupt sources are not retained.

- Boot mode
- Programmer mode

5. Note on programming the product having a 256-Kbyte user MAT

If an attempt is made to program the product having a 256-Kbyte user MAT with more than 256 Kbytes, data programmed after the first 256 Kbytes are not guaranteed.

6. Compatibility with programming/erasing program of conventional F-ZTAT SH microcomputer

A programming/erasing program for flash memory used in the conventional F-ZTAT SH microcomputer which does not support download of the on-chip program by a SCO transfer request cannot run in this LSI.

Be sure to download the on-chip program to execute programming/erasing of flash memory in this LSI.

7. Monitoring runaway by WDT

Unlike the conventional F-ZTAT SH microcomputer, no countermeasures are available for a runaway by WDT during programming/erasing by the downloaded on-chip program.

Prepare countermeasures (e.g. use of the user branch routine and periodic timer interrupts) for WDT while taking the programming/erasing time into consideration as required.

19.9 Supplementary Information

19.9.1 Specifications of the Standard Serial Communications Interface in Boot Mode

The boot program activated in boot mode communicates with the host via the on-chip SCI of the LSI. The specifications of the serial communications interface between the host and the boot program are described below.

- States of the boot program

The boot program has three states.

1. Bit-rate matching state

In this state, the boot program adjusts the bit rate to match that of the host. When the chip starts up in boot mode, the boot program is activated and enters the bit-rate matching state, in which it receives commands from the host and adjusts the bit rate accordingly. After bit-rate matching is complete, the boot program proceeds to the inquiry-and-selection state.

2. Inquiry-and-selection state

In this state, the boot program responds to inquiry commands from the host. The device, clock mode, and bit rate are selected in this state. After making these selections, the boot program enters the programming/erasure state in response to the transition-to-programming/erasure state command. The boot program transfers the erasure program to RAM and executes erasure of the user MAT and user boot MAT before it enters the programming/erasure state.

3. Programming/erasure state

In this state, programming/erasure are executed. The boot program transfers the program for programming/erasure to RAM in line with the command received from the host and executes programming/erasure. It also performs sum checking and blank checking as directed by the respective commands.

Figure 19.21 shows the flow of processing by the boot program.

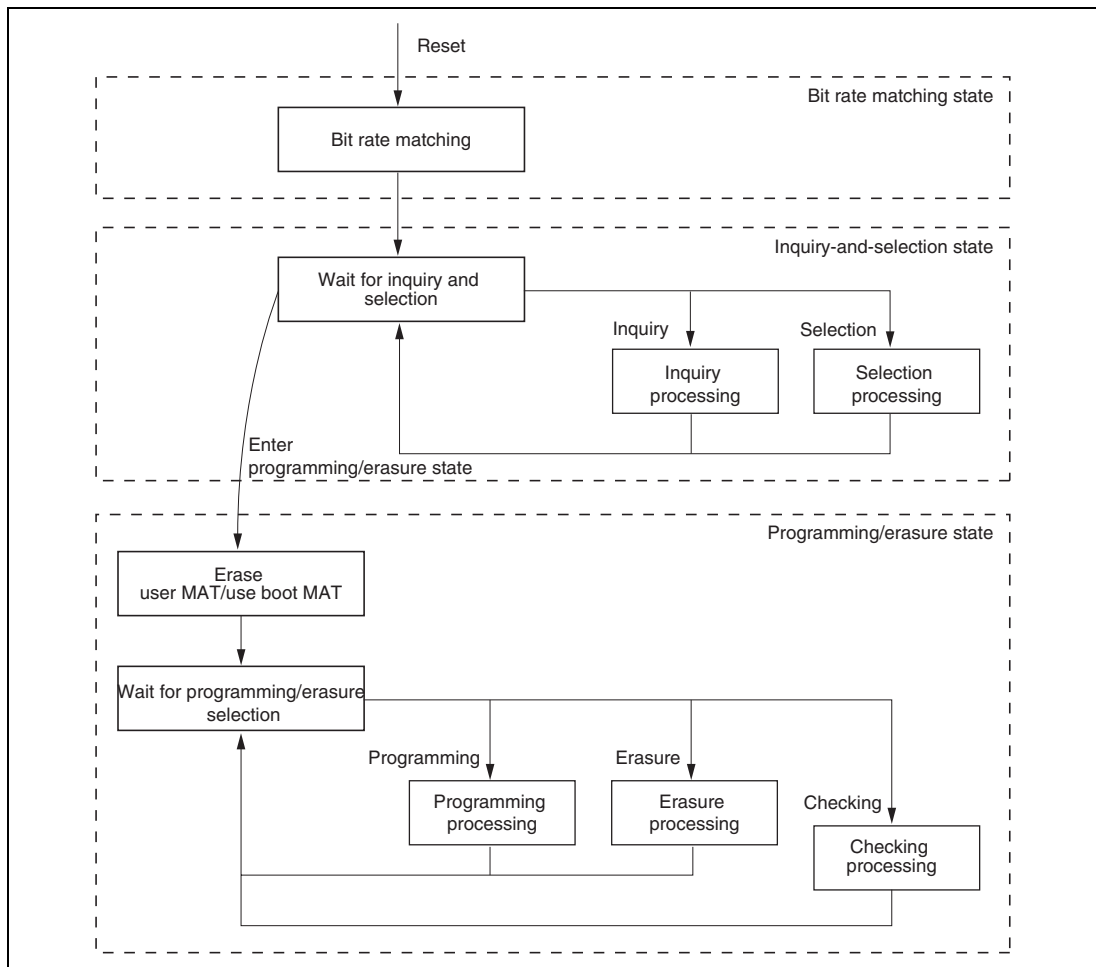

Figure 19.21 Flow of Processing by the Boot Program

- **Bit-rate matching state**

In bit-rate matching, the boot program measures the low-level intervals in a signal carrying H'00 data that is transmitted by the host, and calculates the bit rate from this. The bit rate can be changed by the new-bit-rate selection command. On completion of bit-rate matching, the boot program goes to the inquiry and selection state. The sequence of processing in bit-rate matching is shown in figure 19.22.

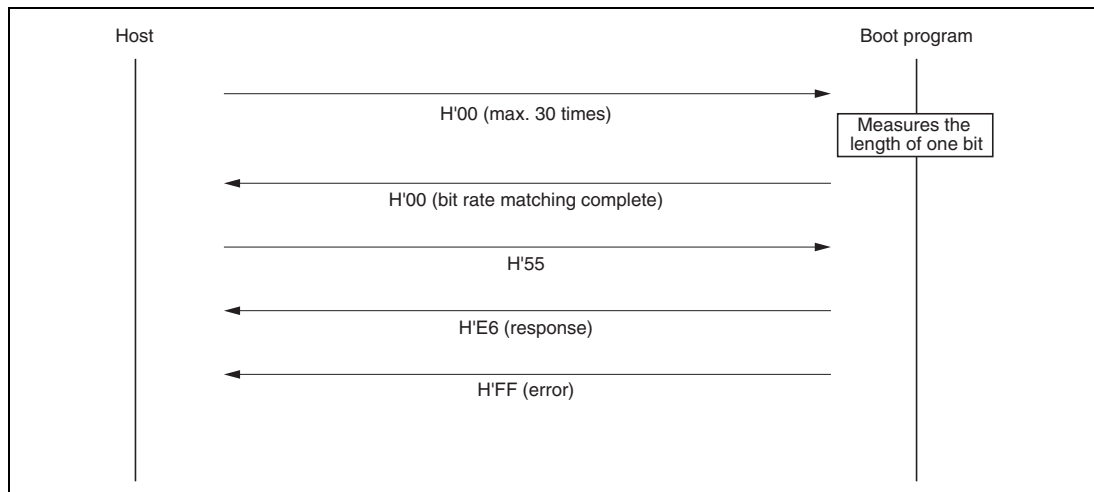

Figure 19.22 Sequence of Bit-Rate Matching

- Communications protocol

Formats in the communications protocol between the host and boot program after completion of the bit-rate matching are as follows.

1. One-character command or one-character response
A command or response consisting of a single character used for an inquiry or the ACK code indicating normal completion.
2. n-character command or n-character response
A command or response that requires n bytes of data, which is used as a selection command or response to an inquiry. The length of programming data is treated separately below.
3. Error response
Response to a command in case of an error: two bytes, consisting of the error response and error code.
4. 128-byte programming command
The command itself does not include data-size information. The data length is known from the response to the command for inquiring about the programming size.
5. Response to a memory reading command
This response includes four bytes of size information.

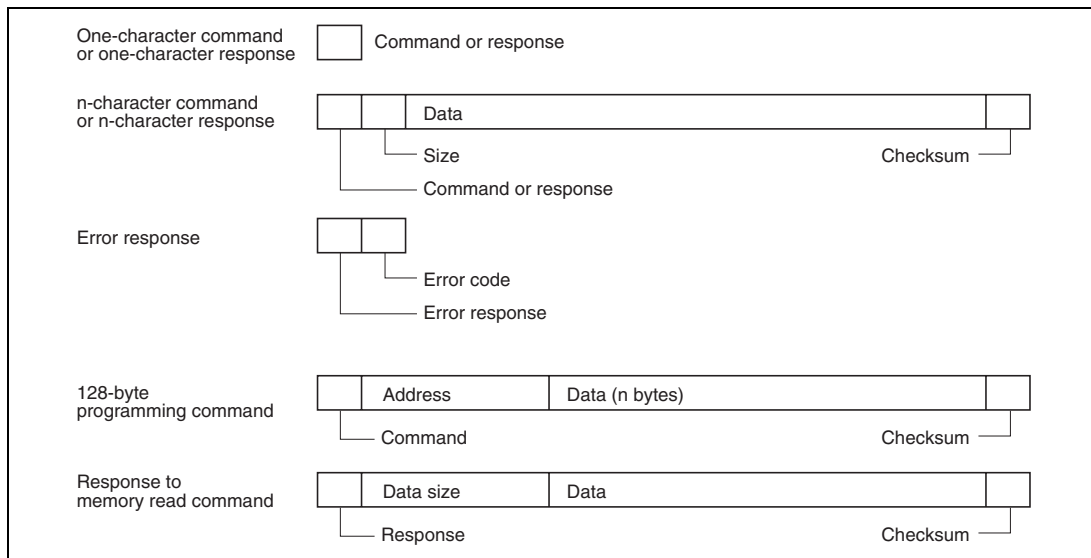

Figure 19.23 Formats in the Communications Protocol

- Command (1 byte): Inquiry, selection, programming, erasure, checking, etc.
- Response (1 byte): Response to an inquiry
- Size (one or two bytes): The length of data for transfer, excluding the command/response code, size, and checksum.
- Data (n bytes): Particular data for the command or response
- Checksum (1 byte): Set so that the total sum of byte values from the command code to the checksum is H'00 in the lower-order 1 byte.
- Error response (1 byte): Error response to a command
- Error code (1 byte): Indicates the type of error.
- Address (4 bytes): Address for programming
- Data (n bytes): Data to be programmed. "n" is known from the response to the command used to inquire about the programming size.
- Data size (4 bytes): Four-byte field included in the response to a memory reading command.

- **Inquiry-and-Selection State**

In this state, the boot program returns information on the flash ROM in response to inquiry commands sent from the host, and selects the device, clock mode, and bit rate in response to the respective selection commands.

The inquiry and selection commands are listed in table 19.13.

Table 19.13 Inquiry and Selection Commands

Command	Command Name	Function
H'20	Inquiry on supported devices	Requests the device codes and their respective boot program names.
H'10	Device selection	Selects a device code.
H'21	Inquiry on clock modes	Requests the number of available clock modes and their respective values.
H'11	Clock-mode selection	Selects a clock mode.
H'22	Inquiry on frequency multipliers	Requests the number of clock signals for which frequency multipliers and divisors are selectable, the number of multiplier and divisor settings for the respective clocks, and the values of the multipliers and divisors.
H'23	Inquiry on operating frequency	Requests the minimum and maximum values for operating frequency of the main clock and peripheral clock.
H'24	Inquiry on user boot MATs	Requests the number of user boot MAT areas along with their start and end addresses.
H'25	Inquiry on user MATs	Requests the number of user MAT areas along with their start and end addresses.
H'26	Inquiry on erasure blocks	Requests the number of erasure blocks along with their start and end addresses.
H'27	Inquiry on programming size	Requests the unit of data for programming.
H'3F	New bit rate selection	Selects a new bit rate.
H'40	Transition to programming/erasure state	On receiving this command, the boot program erases the user MAT and user boot MAT and enters the programming/erasure state.
H'4F	Inquiry on boot program state	Requests information on the current state of boot processing.

The selection commands should be sent by the host in this order: device selection (H'10), clock-mode selection (H'11), new bit rate selection (H'3F). These commands are mandatory. If the same selection command is sent two or more times, the command that is sent last is effective.

All commands in the above table, except for the boot program state inquiry command (H'4F), are valid until the boot program accepts the transition-to-programming/erasure state command (H'40). That is, until the transition command is accepted, the host can continue to send commands listed in the above table until it has made the necessary inquiries and selections. The host can send the boot program state inquiry command (H'4F) even after acceptance of the transition-to-programming/erasure state command (H'40) by the boot program.

(1) Inquiry on supported devices

In response to the inquiry on supported devices, the boot program returns the device codes of the devices it supports and the product names of their respective boot programs.

Command

H'20

— Command H'20 (1 byte): Inquiry on supported devices

Response	H'30	Size	No. of devices	
	Number of characters	Device code		Product name
	...			
	SUM			

— Response H'30 (1 byte): Response to the inquiry on supported devices

— Size (1 byte): The length of data for transfer excluding the command code, this field (size), and the checksum. Here, it is the total number of bytes taken up by the number of devices, number of characters, device code, and product name fields.

— Number of devices (1 byte): The number of device models supported by the boot program embedded in the microcomputer.

— Number of characters (1 byte): The number of characters in the device code and product name fields.

— Device code (4 bytes): Device code of a supported device (ASCII encoded)

— Product name (n bytes): Product code of the boot program (ASCII encoded)

— SUM (1 byte): Checksum

This is set so that the total sum of all bytes from the command code to the checksum is H'00.

(2) Device selection

In response to the device selection command, the boot program sets the specified device as the selected device. The boot program will return the information on the selected device in response to subsequent inquiries.

Command	H'10	Size	Device code	SUM
---------	------	------	-------------	-----

- Command H'10 (1 byte): Device selection
- Size (1 byte): Number of characters in the device code (fixed at 4)
- Device code (4 bytes): A device code that was returned in response to an inquiry on supported devices (ASCII encoded)
- SUM (1 byte): Checksum

Response	H'06
----------	------

- Response H'06 (1 byte): Response to device selection
The ACK code is returned when the specified device code matches one of the supported devices.

Error response	H'90	ERROR
----------------	------	-------

- Error response H'90 (1 byte): Error response to device selection
- ERROR (1 byte): Error code
H'11: Sum-check error
H'21: Non-matching device code

(3) Inquiry on clock modes

In response to the inquiry on clock modes, the boot program returns the number of available clock modes.

Command	H'21
---------	------

- Command H'21 (1 byte): Inquiry on clock modes

Response	H'31	Size	Mode	...	SUM
----------	------	------	------	-----	-----

- Response H'31 (1 byte): Response to the inquiry on clock modes
- Size (1 byte): The total length of the number of modes and mode data fields.
- Mode (1 byte): Selectable clock mode (example: H'01 denotes clock mode 1)
- SUM (1 byte): Checksum

(4) Clock-mode selection

In response to the clock-mode selection command, the boot program sets the specified clock mode. The boot program will return the information on the selected clock mode in response to subsequent inquiries.

Command	H'11	Size	Mode	SUM
---------	------	------	------	-----

- Command H'11 (1 byte): Clock mode selection
- Size (1 byte): Number of characters in the clock-mode field (fixed at 1)
- Mode (1 byte): A clock mode returned in response to the inquiry on clock modes
- SUM (1 byte): Checksum

Response	H'06
----------	------

- Response H'06 (1 byte): Response to clock mode selection
The ACK code is returned when the specified clock-mode matches one of the available clock modes.

Error response	H'91	ERROR
----------------	------	-------

- Error response H'91 (1 byte): Error response to clock mode selection
- ERROR (1 byte): Error code
 - H'11: Sum-check error
 - H'21: Non-matching clock mode

(5) Inquiry on frequency multipliers

In response to the inquiry on frequency multipliers, the boot program returns information on the settable frequency multipliers or divisors.

Command

H'22

— Command H'22 (1 byte): Inquiry on frequency multipliers

Response	H'32	Size	No. of operating clocks					
	No. of multipliers	Multiplier	...					
	...							
	SUM							

— Response H'32 (1 byte): Response to the inquiry on frequency multipliers

— Size (1 byte): The total length of the number of operating clocks, number of multipliers, and multiplier fields.

— Number of operating clocks (1 byte): The number of operating clocks for which multipliers can be selected
(for example, if frequency multiplier settings can be made for the frequencies of the main and peripheral operating clocks, the value should be H'02).

— Number of multipliers (1 byte): The number of multipliers selectable for the operating frequency of the main or peripheral modules

— Multiplier (1 byte):

Multiplier: Numerical value in the case of frequency multiplication (e.g. H'04 for ×4)

Divisor: Two's complement negative numerical value in the case of frequency division (e.g. H'FE [-2] for ×1/2)

As many multiplier fields are included as there are multipliers or divisors, and combinations of the number of multipliers and multiplier fields are repeated as many times as there are operating clocks.

— SUM (1 byte): Checksum

(6) Inquiry on operating frequency

In response to the inquiry on operating frequency, the boot program returns the number of operating frequencies and the maximum and minimum values.

Command

H'23

— Command H'23 (1 byte): Inquiry on operating frequency

Response	H'33	Size	No. of operating clocks
	Operating freq. (min)		Operating freq. (max)
	...		
	SUM		

— Response H'33 (1 byte): Response to the inquiry on operating frequency

— Size (1 byte): The total length of the number of operating clocks, and maximum and minimum values of operating frequency fields.

— Number of operating clocks (1 byte): The number of operating clock frequencies required within the device.

For example, the value two indicates main and peripheral operating clock frequencies.

— Minimum value of operating frequency (2 bytes): The minimum frequency of a frequency-multiplied or -divided clock signal.

The value in this field and in the maximum value field is the frequency in MHz to two decimal places, multiplied by 100 (for example, if the frequency is 20.00 MHz, the value multiplied by 100 is 2000, so H'07D0 is returned here).

— Maximum value of operating frequency (2 bytes): The maximum frequency of a frequency-multiplied or -divided clock signal.

As many pairs of minimum/maximum values are included as there are operating clocks.

— SUM (1 byte): Checksum

(7) Inquiry on user boot MATs

In response to the inquiry on user boot MATs, the boot program returns the number of user boot MAT areas and their addresses.

Command

H'24

— Command H'24 (1 byte): Inquiry on user boot MAT information

Response	H'34	Size	No. of areas		
	First address of the area			Last address of the area	
	...				
	SUM				

— Response H'34 (1 byte): Response to the inquiry on user boot MATs

— Size (1 byte): The total length of the number of areas and first and last address fields.

— Number of areas (1 byte): The number of user boot MAT areas.

H'01 is returned if the entire user boot MAT area is continuous.

— First address of the area (4 bytes)

— Last address of the area (4 bytes)

As many pairs of first and last address field are included as there are areas.

— SUM (1 byte): Checksum

(8) Inquiry on user MATs

In response to the inquiry on user MATs, the boot program returns the number of user MAT areas and their addresses.

Command

H'25

— Command H'25 (1 byte): Inquiry on user MAT information

Response	H'35	Size	No. of areas		
	First address of the area			Last address of the area	
	...				
	SUM				

- Response H'35 (1 byte): Response to the inquiry on user MATs
- Size (1 byte): The total length of the number of areas and first and last address fields.
- Number of areas (1 byte): The number of user MAT areas.
H'01 is returned if the entire user MAT area is continuous.
- First address of the area (4 bytes)
- Last address of the area (4 bytes)
As many pairs of first and last address field are included as there are areas.
- SUM (1 byte): Checksum

(9) Inquiry on erasure blocks

In response to the inquiry on erasure blocks, the boot program returns the number of erasure blocks in the user MAT and the addresses where each block starts and ends.

Command

H'26

- Command H'26 (1 byte): Inquiry on erasure blocks

Response	H'36	Size	No. of blocks	
	First address of the block			Last address of the block
	...			
	SUM			

- Response H'36 (1 byte): Response to the inquiry on erasure blocks
- Size (2 bytes): The total length of the number of blocks and first and last address fields.
- Number of blocks (1 byte): The number of erasure blocks in flash memory
- First address of the block (4 bytes)
- Last address of the block (4 bytes)
As many pairs of first and last address data are included as there are blocks.
- SUM (1 byte): Checksum

(10) Inquiry on programming size

In response to the inquiry on programming size, the boot program returns the size, in bytes, of the unit for programming.

Command

H'27

— Command H'27 (1 byte): Inquiry on programming size

Response

H'37	Size	Programming size	SUM
------	------	------------------	-----

— Response H'37 (1 byte): Response to the inquiry on programming size

— Size (1 byte): The number of characters in the programming size field (fixed at 2)

— Programming size (2 bytes): The size of the unit for programming
This is the unit for the reception of data to be programmed.

— SUM (1 byte): Checksum

(11) New bit rate selection

In response to the new-bit-rate selection command, the boot program changes the bit rate setting to the new bit rate and, if the setting was successful, responds to the ACK sent by the host by returning another ACK at the new bit rate.

The new-bit-rate selection command should be sent after clock-mode selection.

Command

Command	H'3F	Size	Bit rate	Input frequency
	No. of multipliers	Multiplier 1	Multiplier 2	
	SUM			

— Command H'3F (1 byte): New bit rate selection

— Size (1 byte): The total length of the bit rate, input frequency, number of multipliers, and multiplier fields

— Bit rate (2 bytes): New bit rate

The bit rate value divided by 100 should be set here (for example, to select 19200 bps, the set H'00C0, which is 192 in decimal notation).

— Input frequency (2 bytes): The frequency of the clock signal fed to the boot program

This should be the frequency in MHz to the second decimal place, multiplied by 100 (for example, if the frequency is 28.882 MHz, the values is truncated to the second decimal place and multiplied by 100, making 2888; so H'0B48 should be set in this field).

- Number of multipliers (1 byte): The number of selectable frequency multipliers and divisors for the device.
This is normally 2, which indicates the main operating frequency and the operating frequency of the peripheral modules.
- Multiplier 1 (1 byte): Multiplier or divisor for the main operating frequency
Multiplier: Numerical value of the frequency multiplier (e.g. H'04 for ×4)
Divisor: Two's complement negative numerical value in the case of frequency division (e.g. H'FE [-2] for ×1/2)
- Multiplier 2 (1 byte): Multiplier or divisor for the peripheral operating frequency
Multiplier: Numerical value of the frequency multiplier (e.g. H'04 for ×4)
Divisor: Two's complement negative numerical value in the case of frequency division (e.g. H'FE [-2] for ×1/2)
- SUM (1 byte): Checksum

Response

H'06

- Response H'06 (1 byte): Response to the new-bit-rate selection command
The ACK code is returned if the specified bit rate was selectable.

Error response

H'BF	ERROR
------	-------

- Error response H'BF (1 byte): Error response to new bit rate selection
- ERROR (1 byte): Error code
 - H'11: Sum-check error
 - H'24: Bit rate selection error (the specified bit rate is not selectable).
 - H'25: Input frequency error (the specified input frequency is not within the range from the minimum to the maximum value).
 - H'26: Frequency multiplier error (the specified multiplier does not match an available one).
 - H'27: Operating frequency error (the specified operating frequency is not within the range from the minimum to the maximum value).

The received data are checked in the following ways.

1. Input frequency

The value of the received input frequency is checked to see if it is within the range of the minimum and maximum values of input frequency for the selected clock mode of the selected device. A value outside the range generates an input frequency error.

2. Multiplier

The value of the received multiplier is checked to see if it matches a multiplier or divisor that is available for the selected clock mode of the selected device. A value that does not match an available ratio generates a frequency multiplier error.

3. Operating frequency

The operating frequency is calculated from the received input frequency and the frequency multiplier or divisor. The input frequency is the frequency of the clock signal supplied to the LSI, while the operating frequency is the frequency at which the LSI is actually driven. The following formulae are used for this calculation.

Operating frequency = input frequency × multiplier, or

Operating frequency = input frequency / divisor

The calculated operating frequency is checked to see if it is within the range of the minimum and maximum values of the operating frequency for the selected clock mode of the selected device. A value outside the range generates an operating frequency error.

4. Bit rate

From the peripheral operating frequency ($P\phi$) and the bit rate (B), the value ($= n$) of the clock select bits (CKS) in the serial mode register (SCSMR) and the value ($= N$) of the bit rate register (SCBRR) are calculated, after which the error in the bit rate is calculated. This error is checked to see if it is smaller than 4%. A result greater than or equal to 4% generates a bit rate selection error. The following formula is used to calculate the error.

$$\text{Error (\%)} = \left\{ \left[\frac{P\phi \times 10^6}{(N + 1) \times B \times 64 \times 2^{2n-1}} \right] - 1 \right\} \times 100$$

When the new bit rate is selectable, the boot program returns an ACK code to the host and then makes the register setting to select the new bit rate. The host then sends an ACK code at the new bit rate, and the boot program responds to this with another ACK code, this time at the new bit rate.

Acknowledge H'06

— Acknowledge H'06 (1 byte): The ACK code sent by the host to acknowledge the new bit rate.

Response H'06

— Response H'06 (1 byte): The ACK code transferred in response to acknowledgement of the new bit rate

The sequence of new bit rate selection is shown in figure 19.24.

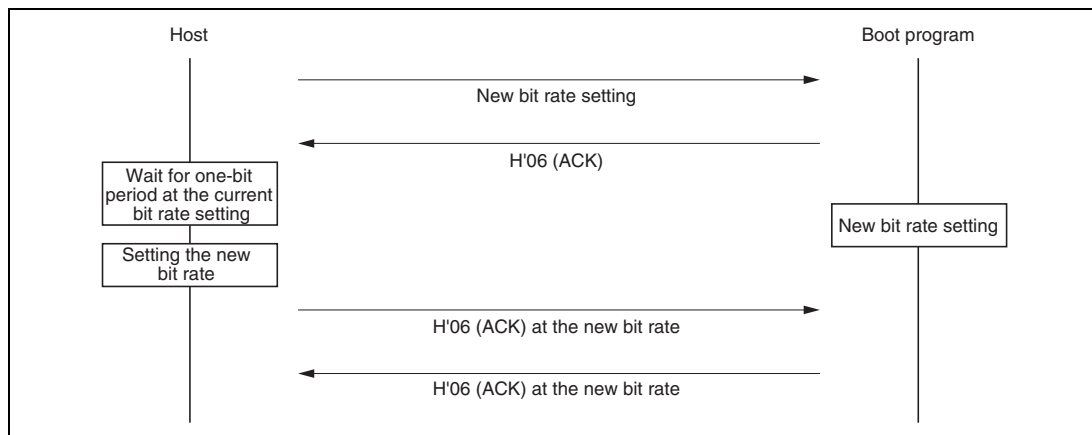

Figure 19.24 Sequence of New Bit Rate Selection

(12) Transition to the programming/erasure state

In response to the transition to the programming/erasure state command, the boot program transfers the erasing program and runs it to erase any data in the user MAT and then the user boot MAT. On completion of this erasure, the boot program returns the ACK code and enters the programming/erasure state.

Before sending the programming selection command and data for programming, the host must select the device, clock mode, and new bit rate for the LSI by issuing the device selection command, clock-mode selection command, new-bit-rate selection command, and then initiate the transition to the programming/erasure state by sending the corresponding command to the boot program.

Command

H'40

— Command H'40 (1 byte): Transition to programming/erasure state

Response

H'06

— Response H'06 (1 byte): Response to the transition-to-programming/erasure state command
This is returned as ACK when erasure of the user boot MAT and user MAT has succeeded after transfer of the erasure program.

Error response

H'C0	H'51
------	------

— Error response H'C0 (1 byte): Error response to the transition-to-programming/erasure state command

— ERROR (1 byte): Error code
H'51: Erasure error (Erasure did not succeed because of an error.)

- Command Error

Command errors are generated by undefined commands, commands sent in an incorrect order, and the inability to accept a command. For example, sending the clock-mode selection command before device selection or an inquiry command after the transition-to-programming/erasure state command generates a command error.

Error response	H'80	H'xx
----------------	------	------

- Error response H'80 (1 byte): Command error
- Command H'xx (1 byte): Received command

- Order of Commands

In the inquiry-and-selection state, commands should be sent in the following order.

1. Send the inquiry on supported devices command (H'20) to get the list of supported devices.
2. Select a device from the returned device information, and send the device selection command (H'10) to select that device.
3. Send the inquiry on clock mode command (H'21) to get the available clock modes.
4. Select a clock mode from among the returned clock modes, and send the clock-mode selection command (H'11).
5. After selection of the device and clock mode, send the commands to inquire about frequency multipliers (H'22) and operating frequencies (H'23) to get the information required to select a new bit rate.
6. Taking into account the returned information on the frequency multipliers and operating frequencies, send a new-bit-rate selection command (H'3F).
7. After the device and clock mode have been selected, get the information required for programming and erasure of the user boot MAT and user MAT by sending the commands to inquire about the user boot MAT (H'24), user MAT (H'25), erasure block (H'26), and programming size (H'27).
8. After making all necessary inquiries and the new bit rate selection, send the transition-to-programming/erasure state command (H'40) to place the boot program in the programming/erasure state.

- **Programming/Erase State**

In this state, the boot program must select the form of programming corresponding to the programming-selection command and then write data in response to 128-byte programming commands, or perform erasure in block units in response to the erasure-selection and block-erasure commands.

The programming and erasure commands are listed in table 19.14.

Table 19.14 Programming and Erasure Commands

Command	Command Name	Function
H'42	Selection of user boot MAT programming	Selects transfer of the program for user boot MAT programming.
H'43	Selection of user MAT programming	Selects transfer of the program for user MAT programming.
H'50	128-byte programming	Executes 128-byte programming.
H'48	Erasure selection	Selects transfer of the erasure program.
H'58	Block erasure	Executes erasure of the specified block.
H'52	Memory read	Reads from memory.
H'4A	Sum checking of user boot MAT	Executes sum checking of the user boot MAT.
H'4B	Sum checking of user MAT	Executes sum checking of the user MAT.
H'4C	Blank checking of user boot MAT	Executes blank checking of the user boot MAT.
H'4D	Blank checking of user MAT	Executes blank checking of the user MAT.
H'4F	Inquiry on boot program state	Requests information on the state of boot processing.

- Programming

Programming is performed by issuing a programming-selection command and the 128-byte programming command.

Firstly, the host issues the programming-selection command to select the MAT to be programmed. Two programming-selection commands are provided for the selection of either of the two target areas.

1. Selection of user boot MAT programming
2. Selection of user MAT programming

Next, the host issues a 128-byte programming command. 128 bytes of data for programming by the method selected by the preceding programming selection command are expected to follow the command. To program more than 128 bytes, repeatedly issue 128-byte programming commands. To terminate programming, the host should send another 128-byte programming command with the address H'FFFFFFFF. On completion of programming, the boot program waits for the next programming/erasure selection command.

To then program the other MAT, start by sending the programming select command.

The sequence of programming by programming-selection and 128-byte programming commands is shown in figure 19.25.

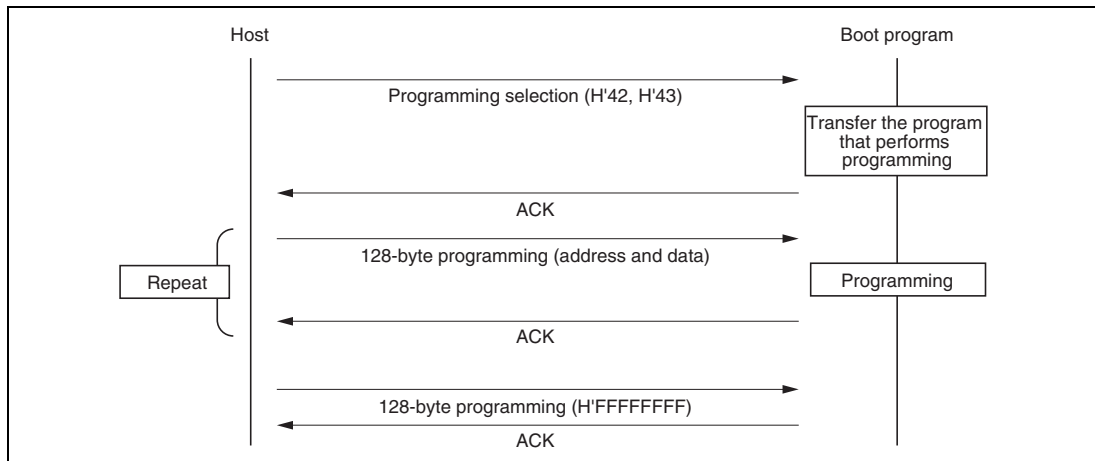

Figure 19.25 Sequence of Programming

(1) Selection of user boot MAT programming

In response to the command for selecting programming of the user boot MAT, the boot program transfers the corresponding flash-writing program, i.e. the program for writing to the user boot MAT.

Command

H'42

— Command H'42 (1 byte): Selects programming of the user boot MAT.

Response

H'06

— Response H'06 (1 byte): Response to selection of user boot MAT programming
This ACK code is returned after transfer of the program that performs writing to the user boot MAT.

Error response

H'C2	ERROR
------	-------

— Error response H'C2 (1 byte): Error response to selection of user boot MAT programming
— ERROR (1 byte): Error code
H'54: Error in selection processing (processing was not completed because of a transfer error)

(2) Selection of user MAT programming

In response to the command for selecting programming of the user MAT, the boot program transfers the corresponding flash-writing program, i.e. the program for writing to the user MAT.

Command

H'43

— Command H'43 (1 byte): Selects programming of the user MAT.

Response

H'06

— Response H'06 (1 byte): Response to selection of user MAT programming
This ACK code is returned after transfer of the program that performs writing to the user MAT.

Error response	H'C3	ERROR
----------------	------	-------

- Error response H'C3 (1 byte): Error response to selection of user MAT programming
- ERROR (1 byte): Error code
 - H'54: Error in selection processing (processing was not completed because of a transfer error)

(3) 128-byte programming

In response to the 128-byte programming command, the boot program executes the flash-writing program transferred in response to the command to select programming of the user boot MAT or user MAT.

Command	H'50	Address for programming						
	Data	...						
	...							
	SUM							

- Command H'50 (1 byte): 128-byte programming
- Address for programming (4 bytes): Address where programming starts
This should be the address of a 128-byte boundary.
[Example] H'00, H01, H'00, H'00: H'00010000
- Programming data (n bytes): Data for programming
The length of the programming data is the size returned in response to the programming size inquiry command.
- SUM (1 byte): Checksum

Response	H'06
----------	------

- Response H'06 (1 byte): Response to 128-byte programming
The ACK code is returned on completion of the requested programming.

Error response	H'D0	ERROR
----------------	------	-------

- Error response H'D0 (1 byte): Error response to 128-byte programming
- ERROR (1 byte): Error code
 - H'11: Sum-check error
 - H'2A: Address error (the address is not within the range for the selected MAT)
 - H'53: Programming error (programming failed because of an error in programming)

The specified address should be on a boundary corresponding to the unit of programming (programming size). For example, when programming 128 bytes of data, the lowest byte of the address should be either H'00 or H'80. When less than 128 bytes of data are to be programmed, the host should transmit the data after padding the vacant bytes with H'FF.

To terminate programming of a given MAT, send a 128-byte programming command with the address field H'FFFFFFF. This informs the boot program that all data for the selected MAT have been sent; the boot program then waits for the next programming/erasure selection command.

Command	H'50	Address for programming	SUM
---------	------	-------------------------	-----

- Command H'50 (1 byte): 128-byte programming
- Address for programming (4 bytes): Terminating code (H'FF, H'FF, H'FF, H'FF)
- SUM (1 byte): Checksum

Response	H'06
----------	------

- Response H'06 (1 byte): Response to 128-byte programming
This ACK code is returned on completion of the requested programming.

Error response	H'D0	ERROR
----------------	------	-------

- Error response H'D0 (1 byte): Error response to 128-byte programming
- ERROR (1 byte): Error code
 - H'11: Sum-check error
 - H'53: Programming error

- Erasure

Erasure is performed by issuing the erasure selection command and then one or more block erasure commands.

Firstly, the host sends the erasure selection command to select erasure; after that, it sends a block erasure command to actually erase a specific block. To erase multiple blocks, send further block erasure commands. To terminate erasure, the host should send a block erasure command with the block number H'FF. After this, the boot program waits for the next programming/erasure selection command.

The sequence of erasure by the erasure selection command and block erasure command is shown in figure 19.26.

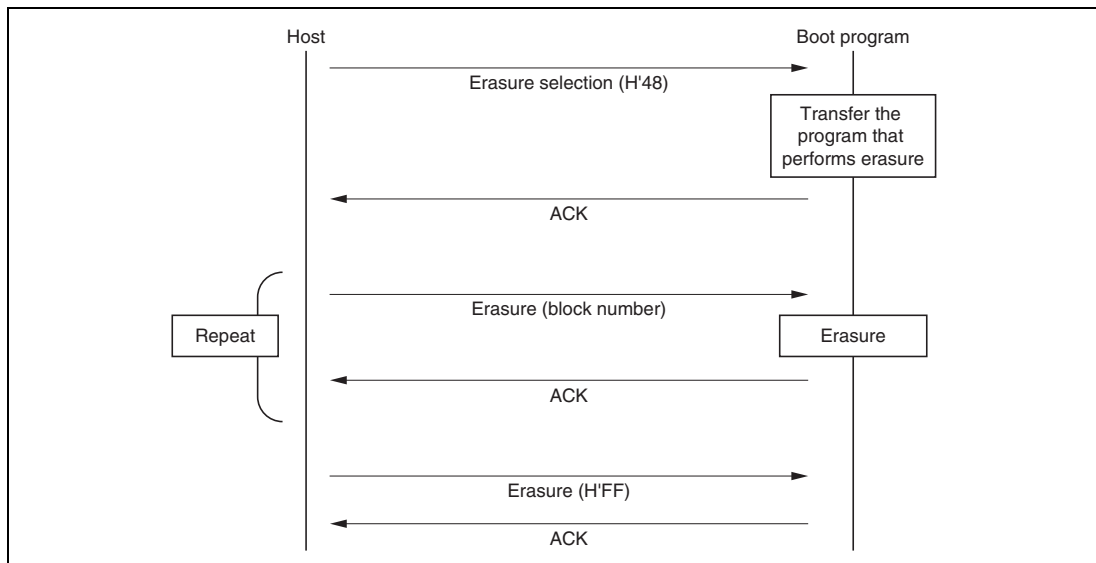

Figure 19.26 Sequence of Erasure

(1) Select erasure

In response to the erasure selection command, the boot program transfers the program that performs erasure, i.e. erases data in the user MAT.

Command

H'48

— Command H'48 (1 byte): Selects erasure.

Response

H'06

— Response H'06 (1 byte): Response to selection of erasure
This ACK code is returned after transfer of the program that performs erasure.

Error response

H'C8	ERROR
------	-------

— Error response H'C8 (1 byte): Error response to selection of erasure
— ERROR (1 byte): Error code
H'54: Error in selection processing (processing was not completed because of a transfer error.)

(2) Block erasure

In response to the block erasure command, the boot program erases the data in a specified block of the user MAT.

Command

H'58	Size	Block number	SUM
------	------	--------------	-----

— Command H'58 (1 byte): Erasure of a block
— Size (1 byte): The number of characters in the block number field (fixed at 1)
— Block number (1 byte): Block number of the block to be erased
— SUM (1 byte): Checksum

Response

H'06

— Response H'06 (1 byte): Response to the block erasure command
This ACK code is returned when the block has been erased.

Error
response

H'D8	ERROR
------	-------

- Error response H'D8 (1 byte): Error response to the block erasure command
- ERROR (1 byte): Error code
 - H'11: Sum-check error
 - H'29: Block number error (the specified block number is incorrect.)
 - H'51: Erasure error (an error occurred during erasure.)

On receiving the command with H'FF as the block number, the boot program stops erasure processing and waits for the next programming/erasure selection command.

Command

H'58	Size	Block number	SUM
------	------	--------------	-----

- Command H'58 (1 byte): Erasure of a block
- Size (1 byte): The number of characters in the block number field (fixed at 1)
- Block number (1 byte): H'FF (erasure terminating code)
- SUM (1 byte): Checksum

Response

H'06

- Response H'06 (1 byte): ACK code to indicate response to the request for termination of erasure

To perform erasure again after having issued the command with the block number specified as H'FF, execute the process from the selection of erasure.

- Memory read

In response to the memory read command, the boot program returns the data from the specified address.

Command

H'52	Size	Area	First address for reading
Amount to read			SUM

- Command H'52 (1 byte): Memory read
- Size (1 byte): The total length of the area, address for reading, and amount to read fields (fixed value of 9)

- Area (1 byte):
H'00: User boot MAT
H'01: User MAT
An incorrect area specification will produce an address error.
- Address where reading starts (4 bytes)
- Amount to read (4 bytes): The amount of data to be read
- SUM (1 byte): Checksum

Response	H'52	Amount to read						
	Data	...						
	SUM							

- Response H'52 (1 byte): Response to the memory read command
- Amount to read (4 bytes): The amount to read as specified in the memory read command
- Data (n bytes): The specified amount of data read out from the specified address
- SUM (1 byte): Checksum

Error response	H'D2	ERROR
----------------	------	-------

- Error response H'D2 (1 byte): Error response to memory read command
- ERROR (1 byte): Error code
H'11: Sum-check error
H'2A: Address error (the address specified for reading is beyond the range of the MAT)
H'2B: Size error (the specified amount is greater than the size of the MAT, the last address for reading as calculated from the specified address for the start of reading and the amount to read is beyond the MAT area, or "0" was specified as the amount to read)

- Sum checking of the user boot MAT

In response to the command for sum checking of the user boot MAT, the boot program adds all bytes of data in the user boot MAT and returns the result.

Command

H'4A

— Command H'4A (1 byte): Sum checking of the user boot MAT

Response

H'5A	Size	Checksum for the MAT	SUM
------	------	----------------------	-----

— Response H'5A (1 byte): Response to sum checking of the user boot MAT

— Size (1 byte): The number of characters in the checksum for the MAT (fixed at 4)

— Checksum for the MAT (4 bytes): Result of checksum calculation for the user boot MAT: the total of all data in the MAT, in byte units.

— SUM (1 byte): Checksum (for the transmitted data)

- Sum checking of the user MAT

In response to the command for sum checking of the user MAT, the boot program adds all bytes of data in the user MAT and returns the result.

Command

H'4B

— Command H'4B (1 byte): Sum checking of the user MAT

Response

H'5B	Size	Checksum for the MAT	SUM
------	------	----------------------	-----

— Response H'5B (1 byte): Response to sum checking of the user MAT

— Size (1 byte): The number of characters in the checksum for the MAT (fixed at 4)

— Checksum for the MAT (4 bytes): Result of checksum calculation for the user MAT: the total of all data in the MAT, in byte units.

— SUM (1 byte): Checksum (for the transmitted data)

- Blank checking of the user boot MAT

In response to the command for blank checking of the user boot MAT, the boot program checks to see if the whole of the user boot MAT is blank; the value returned indicates the result.

Command

H'4C

— Command H'4C (1 byte): Blank checking of the user boot MAT

Response

H'06

— Response H'06 (1 byte): Response to blank checking of the user boot MAT
This ACK code is returned when the whole area is blank (all bytes are H'FF).

Error response

H'CC	H'52
------	------

— Error response H'CC (1 byte): Error response to blank checking of the user boot MAT

— Error code H'52 (1 byte): Non-erased error

- Blank checking of the user MAT

In response to the command for blank checking of the user MAT, the boot program checks to see if the whole of the user MAT is blank; the value returned indicates the result.

Command

H'4D

— Command H'4D (1 byte): Blank checking of the user boot MAT

Response

H'06

— Response H'06 (1 byte): Response to blank checking of the user MAT
The ACK code is returned when the whole area is blank (all bytes are H'FF).

Error response

H'CD	H'52
------	------

— Error response H'CD (1 byte): Error response to blank checking of the user MAT

— Error code H'52 (1 byte): Non-erased error

- Inquiry on boot program state

In response to the command for inquiry on the state of the boot program, the boot program returns an indicator of its current state and error information. This inquiry can be made in the inquiry-and-selection state or the programming/erasure state.

Command

H'4F

— Command H'4F (1 byte): Inquiry on boot program state

Response

H'5F	Size	STATUS	ERROR	SUM
------	------	--------	-------	-----

— Response H'5F (1 byte): Response to the inquiry regarding boot-program state

— Size (1 byte): The number of characters in STATUS and ERROR (fixed at 2)

— STATUS (1 byte): State of the standard boot program
See table 19.15, Status Codes.

— ERROR (1 byte): Error state (indicates whether the program is in normal operation or an error has occurred)
ERROR = 0: Normal
ERROR ≠ 0: Error
See table 19.16, Error Codes.

— SUM (1 byte): Checksum

Table 19.15 Status Codes

Code	Description
H'11	Waiting for device selection
H'12	Waiting for clock-mode selection
H'13	Waiting for bit-rate selection
H'1F	Waiting for transition to programming/erasure status (bit-rate selection complete)
H'31	Erasing the user MAT or user boot MAT
H'3F	Waiting for programming/erasure selection (erasure complete)
H'4F	Waiting to receive data for programming (programming complete)
H'5F	Waiting for erasure block specification (erasure complete)

Table 19.16 Error Codes

Code	Description
H'00	No error
H'11	Sum check error
H'21	Non-matching device code error
H'22	Non-matching clock mode error
H'24	Bit-rate selection failure
H'25	Input frequency error
H'26	Frequency multiplier error
H'27	Operating frequency error
H'29	Block number error
H'2A	Address error
H'2B	Data length error (size error)
H'51	Erase error
H'52	Non-erased error
H'53	Programming error
H'54	Selection processing error
H'80	Command error
H'FF	Bit-rate matching acknowledge error

19.9.2 Areas for Storage of the Procedural Program and Data for Programming

In the descriptions in the previous section, storable areas for the programming/erasing procedure programs and program data are assumed to be in on-chip RAM. However, the procedure programs and data can be stored in and executed from other areas (e.g. external address space) as long as the following conditions are satisfied.

1. The on-chip programming/erasing program is downloaded from the address set by FTDAR in on-chip RAM, therefore, this area is not available for use.
2. The on-chip programming/erasing program will use 128 bytes or more as a stack. Make sure this area is reserved.
3. Since download by setting the SCO bit to 1 will cause the MATs to be switched, it should be executed in on-chip RAM.
4. The flash memory is accessible until the start of programming or erasing, that is, until the result of downloading has been decided. When in a mode in which the external address space

- is not accessible, such as single-chip mode, the required procedure programs, interrupt vector table, interrupt processing routine, and user branch program should be transferred to on-chip RAM before programming/erasing of the flash memory starts.
5. The flash memory is not accessible during programming/erasing operations. Therefore, the programming/erasing program must be downloaded to on-chip RAM in advance. Areas for executing each procedure program for initiating programming/erasing, the user program at the user branch destination for programming/erasing, the interrupt vector table, and the interrupt processing routine must be located in on-chip memory other than flash memory or the external address space.
 6. After programming/erasing, access to flash memory is inhibited until FKEY is cleared.
A reset state ($\overline{\text{RES}} = 0$) for more than at least 100 μs must be taken when the LSI mode is changed to reset on completion of a programming/erasing operation.
Transitions to the reset state during programming/erasing are inhibited. When the reset signal is accidentally input to the LSI, a longer period in the reset state than usual (100 μs) is needed before the reset signal is released.
 7. Switching of the MATs by FMATS is needed for programming/erasing of the user MAT in user boot mode. The program which switches the MATs should be executed from the on-chip RAM. For details, see section 19.8.1, Switching between User MAT and User Boot MAT. Please make sure you know which MAT is selected when switching the MATs.
 8. When the program data storage area indicated by the FMPDR parameter in the programming processing is within the flash memory area, an error will occur. Therefore, temporarily transfer the program data to on-chip RAM to change the address set in FMPDR to an address other than flash memory.

Based on these conditions, tables 19.17 and 19.18 show the areas in which the program data can be stored and executed according to the operation type and mode.

Table 19.17 Executable MAT

Operation	Initiated Mode	
	User Program Mode	User Boot Mode*
Programming	Table 19.18 (1)	Table 19.18 (3)
Erasing	Table 19.18 (2)	Table 19.18 (4)

Note: * Programming/Erasing is possible to user MATs.

Table 19.18 (1) Usable Area for Programming in User Program Mode

Item	Storable/Executable Area			Selected MAT	
	On-Chip RAM	User MAT	External Space	User MAT	Embedded Program Storage MAT
Program data storage area	√	X*	√	—	—
Selecting on-chip program to be downloaded	√	√	√	√	
Writing H'A5 to key register	√	√	√	√	
Writing 1 to SCO in FCCS (download)	√	X	X		√
Key register clearing	√	√	√	√	
Judging download result	√	√	√	√	
Download error processing	√	√	√	√	
Setting initialization parameters	√	√	√	√	
Initialization	√	X	X	√	
Judging initialization result	√	√	√	√	
Initialization error processing	√	√	√	√	
Interrupt processing routine	√	X	√	√	
Writing H'5A to key register	√	√	√	√	
Setting programming parameters	√	X	√	√	
Programming	√	X	X	√	
Judging programming result	√	X	√	√	
Programming error processing	√	X	√	√	
Key register clearing	√	X	√	√	

Note: * If the data has been transferred to on-chip RAM in advance, this area can be used.

Table 19.18 (2) Usable Area for Erasure in User Program Mode

Item	Storable/Executable Area			Selected MAT	
	On-Chip RAM	User MAT	External Space	User MAT	Embedded Program Storage MAT
Selecting on-chip program to be downloaded	√	√	√	√	
Writing H'A5 to key register	√	√	√	√	
Writing 1 to SCO in FCCS (download)	√	X	X		√
Key register clearing	√	√	√	√	
Judging download result	√	√	√	√	
Download error processing	√	√	√	√	
Setting initialization parameters	√	√	√	√	
Initialization	√	X	X	√	
Judging initialization result	√	√	√	√	
Initialization error processing	√	√	√	√	
Interrupt processing routine	√	X	√	√	
Writing H'5A to key register	√	√	√	√	
Setting erasure parameters	√	X	√	√	
Erasure	√	X	X	√	
Judging erasure result	√	X	√	√	
Erasing error processing	√	X	√	√	
Key register clearing	√	X	√	√	

Erasing procedure

Table 19.18 (3) Usable Area for Programming in User Boot Mode

Item	Storable/Executable Area			Selected MAT		
	On-Chip RAM	User Boot MAT	External Space	User MAT	User Boot MAT	Embedded Program Storage Area
Program data storage area	√	X* ¹	√	—	—	—
Selecting on-chip program to be downloaded	√	√	√		√	
Writing H'A5 to key register	√	√	√		√	
Writing 1 to SCO in FCCS (download)	√	X	X			√
Key register clearing	√	√	√		√	
Judging download result	√	√	√		√	
Download error processing	√	√	√		√	
Setting initialization parameters	√	√	√		√	
Initialization	√	X	X		√	
Judging initialization result	√	√	√		√	
Initialization error processing	√	√	√		√	
Interrupt processing routine	√	X	√		√	
Switching MATs by FMATS	√	X	X	√		
Writing H'5A to Key Register	√	X	√	√		

Programming procedure

Table 19.18 (3) Usable Area for Programming in User Boot Mode (cont)

	Item	Storable/Executable Area			Selected MAT		
		On-Chip RAM	User Boot MAT	External Space	User MAT	User Boot MAT	Embedded Program Storage Area
Pro-gram-ming proce-dure	Setting programming parameters	√	X	√	√		
	Programming	√	X	X	√		
	Judging programming result	√	X	√	√		
	Programming error processing	√	X* ²	√	√		
	Key register clearing	√	X	√	√		
	Switching MATs by FMATS	√	X	X		√	

- Notes: 1. If the data has been transferred to on-chip RAM in advance, this area can be used.
 2. If the MATs have been switched by FMATS in on-chip RAM, this MAT can be used.

Table 19.18 (4) Usable Area for Erasure in User Boot Mode

Item	Storable/Executable Area			Selected MAT		
	On-Chip RAM	User Boot MAT	External Space	User MAT	User Boot MAT	Embedded Program Storage Area
Erasing procedure	Selecting on-chip program to be downloaded	√	√	√	√	
	Writing H'A5 to key register	√	√	√	√	
	Writing 1 to SCO in FCCS (download)	√	X	X		√
	Key register clearing	√	√	√	√	
	Judging download result	√	√	√	√	
	Download error processing	√	√	√	√	
	Setting initialization parameters	√	√	√	√	
	Initialization	√	X	X	√	
	Judging initialization result	√	√	√	√	
	Initialization error processing	√	√	√	√	
Interrupt processing routine	√	X	√	√		
Switching MATs by FMATS	√	X	X	√		
Writing H'5A to key register	√	X	√	√		
Setting erasure parameters	√	X	√	√		

Table 19.18 (4) Usable Area for Erasure in User Boot Mode (cont)

	Item	Storable/Executable Area			Selected MAT		
		On-Chip RAM	User Boot MAT	External Space	User MAT	User Boot MAT	Embedded Program Storage Area
Erasing procedure	Erasure	√	X	X	√		
	Judging erasure result	√	X	√	√		
	Erasing error processing	√	X*	√	√		
	Key register clearing	√	X	√	√		
	Switching MATs by FMATS	√	X	X		√	

Note: * If the MATs have been switched by FMATS in on-chip RAM, this MAT can be used.

19.10 Programmer Mode

In programmer mode, a PROM programmer can be used to perform programming/erasing via a socket adapter, just as for a discrete flash memory. Use a PROM programmer that supports the Renesas 256-kbyte flash memory on-chip MCU device type (F-ZTATxxxx).

Section 20 Masked ROM

This LSI is available with 256 kbytes of on-chip masked ROM. The on-chip ROM is connected to the CPU and data transfer controller (DTC) through a 32-bit data bus (figure 20.1). The CPU and DTC can access the on-chip ROM in 8, 16, and 32-bit widths. Data in the on-chip ROM can always be accessed from the CPU in one cycle.

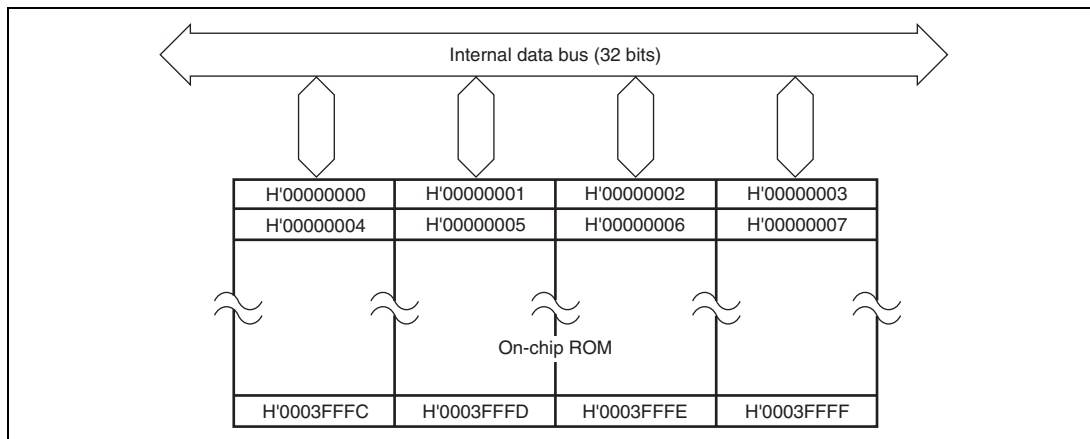

Figure 20.1 Masked ROM Block Diagram

The operating mode determines whether the on-chip ROM is valid or not. The operating mode is selected using mode-setting pins FWE, MD1, and MD0. If you are using the on-chip ROM, select mode 2 or mode 3; if you are not, select mode 0 or 1. The on-chip ROM is allocated to addresses H'00000000 to H'0003FFFF of memory area 0.

20.1 Usage Note

20.1.1 Module Standby Mode Setting

Access to the on-chip ROM can be enabled/disabled by the standby control register. The initial value enables the on-chip ROM operation. On-chip ROM access is disabled by setting the module standby mode. For details, see section 22, Power-Down Modes.

Section 21 RAM

This LSI has an on-chip high-speed static RAM. The on-chip RAM is connected to the CPU by a 32-bit data bus (L bus), and to the data transfer controller (DTC) by a 32-bit data bus (I bus), enabling 8, 16, or 32-bit width access to data in the on-chip RAM.

The on-chip RAM is allocated to different addresses according to each product as shown in figure 21.1, and the on-chip RAM is divided into page 0 and page 1 based on the addresses. The on-chip RAM can be accessed from the CPU (via the L bus) and DTC (via the I bus). When different buses request to access the same page simultaneously, the priority becomes I bus (DTC) > L bus (CPU). Since such kind of conflict degrades the RAM access performance, software should be created so as to avoid conflicts. For example, conflict does not occur when the buses access different pages. An access from the L bus (CPU) is a 1-cycle access as long as page conflict does not occur. The number of bus cycles in accesses from the I bus (DTC) differ depending on the ratio between the internal clock ($I\phi$) and bus clock ($B\phi$), and the operating state of the DTC. The contents of the on-chip RAM are retained in sleep mode or software standby mode, and at a power-on reset or manual reset. However, the contents of the on-chip RAM are not retained in deep software standby mode.

The on-chip RAM can be enabled or disabled by means of the RAME bit in the RAM control register (RAMCR). For details on the RAM control register (RAMCR), refer to section 22.3.7, RAM Control Register (RAMCR).

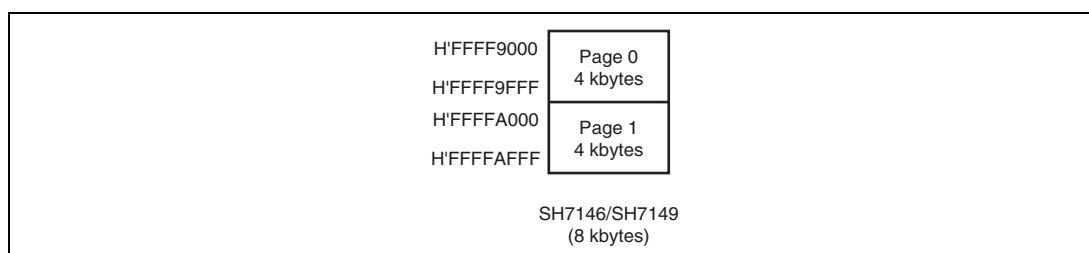

Figure 21.1 On-chip RAM Addresses

21.1 Usage Notes

21.1.1 Module Standby Mode Setting

RAM can be enabled/disabled by the standby control register. The initial value enables RAM operation. RAM access is disabled by setting the module standby mode. For details, see section 22, Power-Down Modes.

21.1.2 Address Error

When an address error in write access to the on-chip RAM occurs, the contents of the on-chip RAM may be corrupted.

21.1.3 Initial Values in RAM

After power has been supplied, initial values in RAM remain undefined until RAM is written.

Section 22 Power-Down Modes

This LSI supports the following power-down modes: sleep mode, software standby mode, deep software standby mode, and module standby mode.

22.1 Features

- Supports sleep mode, software standby mode, module standby mode, and deep software standby mode.

22.1.1 Types of Power-Down Modes

This LSI has the following power-down modes.

- Sleep mode
- Software standby mode
- Deep software standby mode
- Module standby mode

Table 22.1 shows the methods to make a transition from the program execution state, as well as the CPU and peripheral module states in each mode and the procedures for canceling each mode.

Table 22.1 States of Power-Down Modes

Mode	Transition Method	State					On-Chip Peripheral Modules	Canceling Procedure
		CPG	CPU	CPU Register	On-Chip Memory			
Sleep	Execute SLEEP instruction with STBY bit in STBCR1 cleared to 0.	Runs	Halts	Held		Runs	Run	<ul style="list-style-type: none"> Reset
Software standby	Execute SLEEP instruction with STBY bit in STBCR1 and STBYMD bit in STBCR6 set to 1.	Halts	Halts	Held		Halts (contents retained)	Halt	<ul style="list-style-type: none"> Interrupt by NMI or IRQ Power-on reset by the $\overline{\text{RES}}$ pin
Deep software standby	Execute SLEEP instruction with STBY bit in STBCR1 set to 1 and STBYMD bit in STBCR6 cleared to 0.	Halts	Halts	Undefined		Halts (contents undefined)	Halt	<ul style="list-style-type: none"> Power-on reset by the $\overline{\text{RES}}$ pin
Module standby	Set MSTP bits in STBCR2 to STBCR5 to 1.	Runs	Runs	Held		Specified module halts (contents retained)	Specified module halts	<ul style="list-style-type: none"> Clear MSTP bit to 0 Power-on reset (for modules whose MSTP bit has an initial value of 0)

Note: For details on the states of on-chip peripheral module registers in each mode, refer to section 23.3, Register States in Each Operating Mode. For details on the pin states in each mode, refer to appendix A, Pin States.

22.2 Input/Output Pins

Table 22.2 lists the pins used for the power-down modes.

Table 22.2 Pin Configuration

Pin Name	Symbol	I/O	Description
Power-on reset	$\overline{\text{RES}}$	Input	Power-on reset input signal. Power-on reset by low level.
Manual reset	$\overline{\text{MRES}}$	Input	Manual reset input signal. Manual reset by low level.

22.3 Register Descriptions

There are following registers used for the power-down modes. For details on the addresses of these registers and the states of these registers in each processing state, see section 23, List of Registers.

Table 22.3 Register Configuration

Register Name	Abbreviation	R/W	Initial Value	Address	Access Size
Standby control register 1	STBCR1	R/W	H'00	H'FFFFFFE802	8
Standby control register 2	STBCR2	R/W	H'38	H'FFFFFFE804	8
Standby control register 3	STBCR3	R/W	H'FF	H'FFFFFFE806	8
Standby control register 4	STBCR4	R/W	H'FF	H'FFFFFFE808	8
Standby control register 5	STBCR5	R/W	H'03	H'FFFFFFE80A	8
Standby control register 6	STBCR6	R/W	H'00	H'FFFFFFE80C	8
RAM control register	RAMCR	R/W	H'10	H'FFFFFFE880	8

22.3.1 Standby Control Register 1 (STBCR1)

STBCR1 is an 8-bit readable/writable register that specifies the state of the power-down mode.

Bit:	7	6	5	4	3	2	1	0
	STBY	-	-	-	-	-	-	-
Initial value:	0	0	0	0	0	0	0	0
R/W:	R/W	R	R	R	R	R	R	R

Bit	Bit Name	Initial Value	R/W	Description
7	STBY	0	R/W	Standby Specifies transition to software standby mode. 0: Executing SLEEP instruction makes this LSI sleep mode 1: Executing SLEEP instruction makes this LSI software standby mode or deep software standby mode

Bit	Bit Name	Initial Value	R/W	Description
6 to 0	—	All 0	R	Reserved These bits are always read as 0. The write value should always be 0.

22.3.2 Standby Control Register 2 (STBCR2)

STBCR2 is an 8-bit readable/writable register that controls the operation of modules in power-down mode.

Bit:	7	6	5	4	3	2	1	0
	MSTP ₇	MSTP ₆	-	MSTP ₄ *	-	-	-	-
Initial value:	0	0	1	1	1	0	0	0
R/W:	R/W	R/W	R	R/W	R	R	R	R

Note: * The function is available only in the F-ZTAT version. In the masked ROM version, this bit is used as a reserved bit.

Bit	Bit Name	Initial Value	R/W	Description
7	MSTP7	0	R/W	Module Stop Bit 7 When this bit is set to 1, the supply of the clock to the RAM is halted. 0: RAM operates 1: Clock supply to RAM halted
6	MSTP6	0	R/W	Module Stop Bit 6 When this bit is set to 1, the supply of the clock to the ROM is halted. 0: ROM operates 1: Clock supply to ROM halted
5	—	1	R	Reserved This bit is always read as 1. The write value should always be 1.

Bit	Bit Name	Initial Value	R/W	Description
4	MSTP4*	1	R/W	Module Stop Bit 4 When this bit is set to 1, the supply of the clock to the DTC is halted. 0: DTC operates 1: Clock supply to the DTC halted
3	—	1	R	Reserved This bit is always read as 1. The write value should always be 1.
2 to 0	—	All 0	R	Reserved These bits are always read as 0. The write value should always be 0.

Note: * The function is available only in the F-ZTAT version. In the masked ROM version, this bit is used as a reserved bit.

22.3.3 Standby Control Register 3 (STBCR3)

STBCR3 is an 8-bit readable/writable register that controls the operation of modules in power-down mode.

Bit:	7	6	5	4	3	2	1	0
	-	-	MSTP 13	MSTP 12	MSTP 11	-	-	-
Initial value:	1	1	1	1	1	1	1	1
R/W:	R	R	R/W	R/W	R/W	R	R	R

Bit	Bit Name	Initial Value	R/W	Description
7, 6	—	All 1	R	Reserved These bits are always read as 1. The write value should always be 1.
5	MSTP13	1	R/W	Module Stop Bit 13 When this bit is set to 1, the supply of the clock to the SCI_2 is halted. 0: SCI_2 operates 1: Clock supply to SCI_2 halted

Bit	Bit Name	Initial Value	R/W	Description
4	MSTP12	1	R/W	Module Stop Bit 12 When this bit is set to 1, the supply of the clock to the SCI_1 is halted. 0: SCI_1 operates 1: Clock supply to SCI_1 halted
3	MSTP11	1	R/W	Module Stop Bit 11 When this bit is set to 1, the supply of the clock to the SCI_0 is halted. 0: SCI_0 operates 1: Clock supply to SCI_0 halted
2 to 0	—	All 1	R	Reserved These bits are always read as 1. The write value should always be 1.

22.3.4 Standby Control Register 4 (STBCR4)

STBCR4 is an 8-bit readable/writable register that controls the operation of modules in power-down mode.

Bit:	7	6	5	4	3	2	1	0
	MSTP 23	MSTP 22	MSTP 21	-	-	MSTP 18	MSTP 17	MSTP 16
Initial value:	1	1	1	1	1	1	1	1
R/W:	R/W	R/W	R/W	R	R	R/W	R/W	R/W

Bit	Bit Name	Initial Value	R/W	Description
7	MSTP23	1	R/W	Module Stop Bit 23 When this bit is set to 1, the supply of the clock to the MTU2S is halted. 0: MTU2S operates 1: Clock supply to MTU2S halted

Bit	Bit Name	Initial Value	R/W	Description
6	MSTP22	1	R/W	Module Stop Bit 22 When this bit is set to 1, the supply of the clock to the MTU2 is halted. 0: MTU2 operates 1: Clock supply to MTU2 halted
5	MSTP21	1	R/W	Module Stop Bit 21 When this bit is set to 1, the supply of the clock to the CMT is halted. 0: CMT operates 1: Clock supply to CMT halted
4, 3	—	All 1	R	Reserved These bits are always read as 1. The write value should always be 1.
2	MSTP18	1	R/W	Module Stop Bit 18 When this bit is set to 1, the supply of the clock to the A/D_2 is halted. 0: A/D_2 operates 1: Clock supply to A/D_2 halted
1	MSTP17	1	R/W	Module Stop Bit 17 When this bit is set to 1, the supply of the clock to the A/D_1 is halted. 0: A/D_1 operates 1: Clock supply to A/D_1 halted
0	MSTP16	1	R/W	Module Stop Bit 16 When this bit is set to 1, the supply of the clock to the A/D_0 is halted. 0: A/D_0 operates 1: Clock supply to A/D_0 halted

22.3.5 Standby Control Register 5 (STBCR5)

STBCR5 is an 8-bit readable/writable register that controls the operation of modules in power-down mode.

Bit:	7	6	5	4	3	2	1	0
	-	-	-	-	-	-	MSTP 25	MSTP 24
Initial value:	0	0	0	0	0	0	1	1
R/W:	R	R	R	R	R	R	R/W	R/W

Bit	Bit Name	Initial Value	R/W	Description
7 to 2	—	All 0	R	Reserved These bits are always read as 0. The write value should always be 0.
1	MSTP25	1	R/W	Module Stop Bit 25 When this bit is set to 1, the supply of the clock to the AUD is halted. 0: AUD operates 1: Clock supply to AUD halted
0	MSTP24	1	R/W	Module Stop Bit 24 When this bit is set to 1, the supply of the clock to the UBC is halted. 0: UBC operates 1: Clock supply to UBC halted

22.3.6 Standby Control Register 6 (STBCR6)

STBCR6 is an 8-bit readable/writable register that specifies the state of the power-down modes.

Bit:	7	6	5	4	3	2	1	0
	AUD SRST	HIZ	-	-	-	-	STBY MD	-
Initial value:	0	0	0	0	0	0	0	0
R/W:	R/W	R/W	R	R	R	R	R/W	R

Bit	Bit Name	Initial Value	R/W	Description
7	AUDSRST	0	R/W	AUD Software Reset This bit controls the AUD reset by software. When 0 is written to AUDSRST, the AUD module shifts to the power-on reset state. 0: Shifts to the AUD reset state 1: Clears the AUD reset When setting this bit to 1, MSTP25 in STBCR5 should be 0.
6	HIZ	0	R/W	Port High-Impedance In software standby mode, this bit selects whether the pin state is retained or changed to high-impedance. 0: In software standby mode, the pin state is retained 1: In software standby mode, the pin state is changed to high-impedance
5 to 2	—	All 0	R	Reserved These bits are always read as 0. The write value should always be 0.
1	STBYMD	0	R/W	Software Standby Mode Select This bit selects a transition to software standby mode or deep software standby mode by executing the SLEEP instruction when the STBY bit is 1 in STBCR1. 0: Transition to deep software standby mode 1: Transition to software standby mode
0	—	0	R	Reserved This bit is always read as 0. The write value should always be 0.

22.3.7 RAM Control Register (RAMCR)

RAMCR is an 8-bit readable/writable register that enables/disables the access to the on-chip RAM.

Bit:	7	6	5	4	3	2	1	0
	-	-	-	RAME	-	-	-	-
Initial value:	0	0	0	1	0	0	0	0
R/W:	R	R	R	R/W	R	R	R	R

Bit	Bit Name	Initial Value	R/W	Description
7 to 5	—	All 0	R	Reserved These bits are always read as 0. The write value should always be 0.
4	RAME	1	R/W	RAM Enable This bit enables/disables the on-chip RAM. 0: On-chip RAM disabled 1: On-chip RAM enabled When this bit is cleared to 0, the access to the on-chip RAM is disabled. In this case, an undefined value is returned when reading or fetching the data or instruction from the on-chip RAM, and writing to the on-chip RAM is ignored. When RAME is cleared to 0 to disable the on-chip RAM, an instruction to access the on-chip RAM should not be set next to the instruction to write RAMCR. If such an instruction is set, normal access is not guaranteed. When RAME is set to 1 to enable the on-chip RAM, an instruction to read RAMCR should be set next to the instruction to write to RAMCR. If an instruction to access the on-chip RAM is set next to the instruction to write to RAMCR, normal access is not guaranteed.
3 to 0	—	All 0	R	Reserved These bits are always read as 0. The write value should always be 0.

22.4 Sleep Mode

22.4.1 Transition to Sleep Mode

Executing the SLEEP instruction when the STBY bit in STBCR1 is 0 causes a transition from the program execution state to sleep mode. However, sleep mode cannot be entered when the bus is released (low-level input to $\overline{\text{BREQ}}$ pin). Although the CPU halts immediately after executing the SLEEP instruction, the contents of its internal registers remain unchanged. The on-chip peripheral modules continue to operate.

22.4.2 Canceling Sleep Mode

Sleep mode is canceled by a reset.

Do not cancel sleep mode with an interrupt.

Canceling with Reset: Sleep mode is canceled by a power-on reset with the $\overline{\text{RES}}$ pin, a manual reset with the $\overline{\text{MRES}}$ pin, or an internal power-on/manual reset by WDT.

22.5 Software Standby Mode

22.5.1 Transition to Software Standby Mode

This LSI switches from a program execution state to software standby mode by executing the SLEEP instruction when the STBY bit in STBCR1 and the STBYMD bit in STBCR6 are set to 1. However, software standby mode cannot be entered when the bus is released (low-level input to $\overline{\text{BREQ}}$ pin). Execute the SLEEP instruction after halting the DTC. In software standby mode, not only the CPU but also the clock and on-chip peripheral modules halt.

The contents of the CPU registers and the data of the on-chip RAM remain unchanged. Some registers of on-chip peripheral modules are, however, initialized. For details on the states of on-chip peripheral module registers in software standby mode, refer to section 23.3, Register States in Each Operating Mode. For details on the pin states in software standby mode, refer to appendix A, Pin States.

The procedure for switching to software standby mode is as follows:

1. Clear the TME bit in the timer control register (WTCSR) of the WDT to 0 to stop the WDT.
2. Set the timer counter (WTCNT) of the WDT to 0 and bits CKS2 to CKS0 in WTCSR to appropriate values to secure the specified oscillation settling time.
3. If the DTC is operating, stop its operation.
4. If the bus is released (low-level input to $\overline{\text{BREQ}}$ pin), acquire the bus mastership (high-level input to $\overline{\text{BREQ}}$ pin).
5. After setting the STBY bit in STBCR1 and the STBYMD bit in STBCR6 to 1, execute the SLEEP instruction.
6. Software standby mode is entered and the clocks within this LSI are halted.

22.5.2 Canceling Software Standby Mode

Software standby mode is canceled by interrupts (NMI, IRQ) or a reset.

Canceling with Interrupt: The WDT can be used for hot starts. When an NMI or IRQ interrupt (edge detection) is detected, the clock will be supplied to the entire LSI and software standby mode will be canceled after the time set in the timer control/status register of the WDT has elapsed. Interrupt exception handling is then executed.

When the priority level of an IRQ interrupt is lower than the interrupt mask level set in the status register (SR) of the CPU, an interrupt request is not accepted preventing software standby mode from being canceled.

When falling-edge detection is selected for the NMI pin, drive the NMI pin high before making a transition to software standby mode. When rising-edge detection is selected for the NMI pin, drive the NMI pin low before making a transition to software standby mode.

Similarly, when falling-edge detection is selected for the IRQ pin, drive the IRQ pin high before making a transition to software standby mode. When rising-edge detection is selected for the IRQ pin, drive the IRQ pin low before making a transition to software standby mode.

Canceling with Power-on Reset: Software standby mode is canceled by a power-on reset with the $\overline{\text{RES}}$ pin. Keep the $\overline{\text{RES}}$ pin low until the clock oscillation settles.

22.6 Deep Software Standby Mode

22.6.1 Transition to Deep Software Standby Mode

This LSI shifts from a program execution state to deep software standby mode by executing the SLEEP instruction when the STBY bit in STBCR1 is 1 and the STBYMD bit in STBCR6 is 0. However, deep software standby mode cannot be entered when the bus is released (low-level input to $\overline{\text{BREQ}}$ pin). Execute the SLEEP instruction after halting the DTC. In deep software standby mode, not only the CPU but also the clock and on-chip peripheral modules halt. Furthermore, the internal power supply of this LSI is turned off.

The contents of the CPU registers and the data of the on-chip RAM become undefined. The registers of on-chip peripheral modules are initialized. For details on the pin states in deep software standby mode, refer to appendix A, Pin States.

The procedure for a transition to deep software standby mode is as follows:

1. Clear the TME bit in the timer control register (WTCSR) of the WDT to 0 to stop the WDT.
2. If the DTC is operating, stop its operation.
3. If the bus is released (low-level input to $\overline{\text{BREQ}}$ pin), acquire the bus mastership (high-level input to $\overline{\text{BREQ}}$ pin).
4. After setting the STBY bit in STBCR1 to 1 and clearing the STBYMD bit in STBCR6 to 0, execute the SLEEP instruction.
5. Deep software standby mode is entered, the clocks within this LSI are halted, and the internal power supply of this LSI is turned off.

22.6.2 Canceling Deep Software Standby Mode

Deep software standby mode is canceled by a power-on reset with the $\overline{\text{RES}}$ pin. Keep the $\overline{\text{RES}}$ pin low until the clock oscillation settles.

22.7 Module Standby Mode

22.7.1 Transition to Module Standby Mode

Setting the MSTP bits in the standby control registers (STBCR2 to STBCR5) to 1 halts the supply of clocks to the corresponding on-chip peripheral modules. This function can be used to reduce the power consumption in normal mode.

Do not access registers of an on-chip peripheral module which has been set to enter module standby mode. For details on the states of on-chip peripheral module registers in module standby mode, refer to section 23.3, Register States in Each Operating Mode.

22.7.2 Canceling Module Standby Function

The module standby function can be canceled by clearing the MSTP bits in STBCR2 to STBCR5 to 0. The module standby function can be canceled by a power-on reset for modules whose MSTP bit has an initial value of 0.

22.8 Usage Note

22.8.1 Current Consumption while Waiting for Oscillation to be Stabilized

The current consumption while waiting for oscillation to be stabilized is higher than that while oscillation is stabilized.

22.8.2 Executing the SLEEP Instruction

Apply either of the following measures before executing the SLEEP instruction to initiate the transition to sleep mode or software standby mode.

Measure A: Stop the operation of the DTC and the generation of interrupts from on-chip peripheral modules, IRQ interrupts, and the NMI interrupt before executing the SLEEP instruction.

Measure B: Change the value in FRQCR to the initial value, H'36DB, and then dummy-read FRQCR twice before executing the SLEEP instruction.

Section 23 List of Registers

This section gives information on internal I/O registers. The contents of this section are as follows:

1. Register Address Table (in the order from a lower address)
 - Registers are listed in the order from lower allocated addresses.
 - As for reserved addresses, the register name column is indicated with —. Do not access reserved addresses.
 - As for 16- or 32-bit address, the MSB addresses are shown.
 - The list is classified according to module names.
 - The numbers of access cycles are given.
2. Register Bit Table
 - Bit configurations are shown in the order of the register address table.
 - As for reserved bits, the bit name column is indicated with —.
 - As for the blank column of the bit names, the whole register is allocated to the counter or data.
 - As for 16- or 32-bit registers, bits are indicated from the MSB.
3. Register State in Each Operating Mode
 - Register states are listed in the order of the register address table.
 - Register states in the basic operating mode are shown. As for modules including their specific states such as reset, see the sections of those modules.

23.1 Register Address Table (In the Order from Lower Addresses)

Access sizes are indicated with the number of bits. Access states are indicated with the number of specified reference clock states. These values are those at 8-bit access (B), 16-bit access (W), or 32-bit access (L).

Note: Access to undefined or reserved addresses is prohibited. Correct operation cannot be guaranteed if these addresses are accessed.

Register Name	Abbreviation	No. of		Module	Access Size	No. of Access States	Connected Bus Width
		Bits	Address				
Serial mode register_0	SCSMR_0	8	H'FFFFC000	SCI	8	P ϕ reference	16 bits
Bit rate register_0	SCBRR_0	8	H'FFFFC002	(Channel 0)	8	B:2	
Serial control register_0	SCSCR_0	8	H'FFFFC004		8		
Transmit data register_0	SCTDR_0	8	H'FFFFC006		8		
Serial status register_0	SCSSR_0	8	H'FFFFC008		8		
Receive data register_0	SCRDR_0	8	H'FFFFC00A		8		
Serial direction control register_0	SCSDCR_0	8	H'FFFFC00C		8		
Serial port register_0	SCSPTR_0	8	H'FFFFC00E		8		
Serial mode register_1	SCSMR_1	8	H'FFFFC080	SCI	8	P ϕ reference	16 bits
Bit rate register_1	SCBRR_1	8	H'FFFFC082	(Channel 1)	8	B:2	
Serial control register_1	SCSCR_1	8	H'FFFFC084		8		
Transmit data register_1	SCTDR_1	8	H'FFFFC086		8		
Serial status register_1	SCSSR_1	8	H'FFFFC088		8		
Receive data register_1	SCRDR_1	8	H'FFFFC08A		8		
Serial direction control register_1	SCSDCR_1	8	H'FFFFC08C		8		
Serial port register_1	SCSPTR_1	8	H'FFFFC08E		8		
Serial mode register_2	SCSMR_2	8	H'FFFFC100	SCI	8	P ϕ reference	16 bits
Bit rate register_2	SCBRR_2	8	H'FFFFC102	(Channel 2)	8	B:2	
Serial control register_2	SCSCR_2	8	H'FFFFC104		8		
Transmit data register_2	SCTDR_2	8	H'FFFFC106		8		
Serial status register_2	SCSSR_2	8	H'FFFFC108		8		
Receive data register_2	SCRDR_2	8	H'FFFFC10A		8		
Serial direction control register_2	SCSDCR_2	8	H'FFFFC10C		8		
Serial port register_2	SCSPTR_2	8	H'FFFFC10E		8		

Register Name	Abbreviation	No. of		Module	Access Size	No. of Access States	Connected Bus Width
		Bits	Address				
Timer control register_3	TCR_3	8	H'FFFFFFC200	MTU2	8, 16, 32	MP ϕ reference	16 bits
Timer control register_4	TCR_4	8	H'FFFFFFC201		8	B:2	
Timer mode register_3	TMDR_3	8	H'FFFFFFC202		8, 16	W:2	
Timer mode register_4	TMDR_4	8	H'FFFFFFC203		8	L:4	
Timer I/O control register H_3	TIORH_3	8	H'FFFFFFC204		8, 16, 32		
Timer I/O control register L_3	TIORL_3	8	H'FFFFFFC205		8		
Timer I/O control register H_4	TIORH_4	8	H'FFFFFFC206		8, 16		
Timer I/O control register L_4	TIORL_4	8	H'FFFFFFC207		8		
Timer interrupt enable register_3	TIER_3	8	H'FFFFFFC208		8, 16		
Timer interrupt enable register_4	TIER_4	8	H'FFFFFFC209		8		
Timer output master enable register	TOER	8	H'FFFFFFC20A		8		
Timer gate control register	TGCR	8	H'FFFFFFC20D		8		
Timer output control register 1	TOCR1	8	H'FFFFFFC20E		8, 16		
Timer output control register 2	TOCR2	8	H'FFFFFFC20F		8		
Timer counter_3	TCNT_3	16	H'FFFFFFC210		16, 32		
Timer counter_4	TCNT_4	16	H'FFFFFFC212		16		
Timer cycle data register	TCDR	16	H'FFFFFFC214		16, 32		
Timer dead time data register	TDDR	16	H'FFFFFFC216		16		
Timer general register A_3	TGRA_3	16	H'FFFFFFC218		16, 32		
Timer general register B_3	TGRB_3	16	H'FFFFFFC21A		16		
Timer general register A_4	TGRA_4	16	H'FFFFFFC21C		16, 32		
Timer general register B_4	TGRB_4	16	H'FFFFFFC21E		16		
Timer sub-counter	TCNTS	16	H'FFFFFFC220		16, 32		
Timer cycle buffer register	TCBR	16	H'FFFFFFC222		16		
Timer general register C_3	TGRC_3	16	H'FFFFFFC224		16, 32		
Timer general register D_3	TGRD_3	16	H'FFFFFFC226		16		
Timer general register C_4	TGRC_4	16	H'FFFFFFC228		16, 32		
Timer general register D_4	TGRD_4	16	H'FFFFFFC22A		16		
Timer status register_3	TSR_3	8	H'FFFFFFC22C		8, 16		
Timer status register_4	TSR_4	8	H'FFFFFFC22D		8		
Timer interrupt skipping set register	TITCR	8	H'FFFFFFC230		8, 16		

Register Name	Abbreviation	No. of		Module	Access Size	No. of Access States	Connected Bus Width
		Bits	Address				
Timer interrupt skipping counter	TITCNT	8	H'FFFFFFC231	MTU2	8	MP ϕ reference	16 bits
Timer buffer transfer set register	TBTER	8	H'FFFFFFC232		8	B:2	
Timer dead time enable register	TDER	8	H'FFFFFFC234		8	W:2	
Timer output level buffer register	TOLBR	8	H'FFFFFFC236		8	L:4	
Timer buffer operation transfer mode register_3	TBTM_3	8	H'FFFFFFC238		8, 16		
Timer buffer operation transfer mode register_4	TBTM_4	8	H'FFFFFFC239		8		
Timer A/D converter start request control register	TADCR	16	H'FFFFFFC240		16		
Timer A/D converter start request cycle set register A_4	TADCORA_4	16	H'FFFFFFC244		16, 32		
Timer A/D converter start request cycle set register B_4	TADCORB_4	16	H'FFFFFFC246		16		
Timer A/D converter start request cycle set buffer register A_4	TADCOBRA_4	16	H'FFFFFFC248		16, 32		
Timer A/D converter start request cycle set buffer register B_4	TADCOBRB_4	16	H'FFFFFFC24A		16		
Timer waveform control register	TWCR	8	H'FFFFFFC260		8		
Timer start register	TSTR	8	H'FFFFFFC280		8, 16		
Timer synchronous register	TSYR	8	H'FFFFFFC281		8		
Timer counter synchronous start register	TCSYSTR	8	H'FFFFFFC282		8		
Timer read/write enable register	TRWER	8	H'FFFFFFC284		8		
Timer control register_0	TCR_0	8	H'FFFFFFC300		8, 16, 32		
Timer mode register_0	TMDR_0	8	H'FFFFFFC301		8		
Timer I/O control register H_0	TIORH_0	8	H'FFFFFFC302		8, 16		
Timer I/O control register L_0	TIORL_0	8	H'FFFFFFC303		8		
Timer interrupt enable register_0	TIER_0	8	H'FFFFFFC304		8, 16, 32		
Timer status register_0	TSR_0	8	H'FFFFFFC305		8		
Timer counter_0	TCNT_0	16	H'FFFFFFC306		16		
Timer general register A_0	TGRA_0	16	H'FFFFFFC308		16, 32		
Timer general register B_0	TGRB_0	16	H'FFFFFFC30A		16		

Register Name	Abbreviation	No. of		Module	Access Size	No. of Access States	Connected Bus Width
		Bits	Address				
Timer general register C_0	TGRC_0	16	H'FFFFFF30C	MTU2	16, 32	MP ϕ reference	16 bits
Timer general register D_0	TGRD_0	16	H'FFFFFF30E		16	B:2	
Timer general register E_0	TGRE_0	16	H'FFFFFF320		16, 32	W:2	
Timer general register F_0	TGRF_0	16	H'FFFFFF322		16	L:4	
Timer interrupt enable register 2_0	TIER2_0	8	H'FFFFFF324		8, 16		
Timer status register 2_0	TSR2_0	8	H'FFFFFF325		8		
Timer buffer operation transfer mode register_0	TBTM_0	8	H'FFFFFF326		8		
Timer control register_1	TCR_1	8	H'FFFFFF380		8, 16		
Timer mode register_1	TMDR_1	8	H'FFFFFF381		8		
Timer I/O control register_1	TIOR_1	8	H'FFFFFF382		8		
Timer interrupt enable register_1	TIER_1	8	H'FFFFFF384		8, 16, 32		
Timer status register_1	TSR_1	8	H'FFFFFF385		8		
Timer counter_1	TCNT_1	16	H'FFFFFF386		16		
Timer general register A_1	TGRA_1	16	H'FFFFFF388		16, 32		
Timer general register B_1	TGRB_1	16	H'FFFFFF38A		16		
Timer input capture control register	TICCR	8	H'FFFFFF390		8		
Timer control register_2	TCR_2	8	H'FFFFFF400		8, 16		
Timer mode register_2	TMDR_2	8	H'FFFFFF401		8		
Timer I/O control register_2	TIOR_2	8	H'FFFFFF402		8		
Timer interrupt enable register_2	TIER_2	8	H'FFFFFF404		8, 16, 32		
Timer status register_2	TSR_2	8	H'FFFFFF405		8		
Timer counter_2	TCNT_2	16	H'FFFFFF406		16		
Timer general register A_2	TGRA_2	16	H'FFFFFF408		16, 32		
Timer general register B_2	TGRB_2	16	H'FFFFFF40A		16		
Timer counter U_5	TCNTU_5	16	H'FFFFFF480		16, 32		
Timer general register U_5	TGRU_5	16	H'FFFFFF482		16		
Timer control register U_5	TCRU_5	8	H'FFFFFF484		8		
Timer I/O control register U_5	TIORU_5	8	H'FFFFFF486		8		
Timer counter V_5	TCNTV_5	16	H'FFFFFF490		16, 32		
Timer general register V_5	TGRV_5	16	H'FFFFFF492		16		

Register Name	Abbreviation	No. of		Module	Access Size	No. of Access States	Connected Bus Width
		Bits	Address				
Timer control register V_5	TCRV_5	8	H'FFFFFFC494	MTU2	8	MP ϕ reference	16 bits
Timer I/O control register V_5	TIORV_5	8	H'FFFFFFC496		8	B:2	
Timer counter W_5	TCNTW_5	16	H'FFFFFFC4A0		16, 32	W:2	
Timer general register W_5	TGRW_5	16	H'FFFFFFC4A2		16	L:4	
Timer control register W_5	TCRW_5	8	H'FFFFFFC4A4		8		
Timer I/O control register W_5	TIORW_5	8	H'FFFFFFC4A6		8		
Timer status register_5	TSR_5	8	H'FFFFFFC4B0		8		
Timer interrupt enable register_5	TIER_5	8	H'FFFFFFC4B2		8		
Timer start register_5	TSTR_5	8	H'FFFFFFC4B4		8		
Timer compare match clear register	TCNTCMPCLR	8	H'FFFFFFC4B6		8		
Timer control register_3S	TCR_3S	8	H'FFFFFFC600	MTU2S	8, 16, 32	MP ϕ reference	16 bits
Timer control register_4S	TCR_4S	8	H'FFFFFFC601		8	B:2	
Timer mode register_3S	TMDR_3S	8	H'FFFFFFC602		8, 16	W:2	
Timer mode register_4S	TMDR_4S	8	H'FFFFFFC603		8	L:4	
Timer I/O control register H_3S	TIORH_3S	8	H'FFFFFFC604		8, 16, 32		
Timer I/O control register L_3S	TIORL_3S	8	H'FFFFFFC605		8		
Timer I/O control register H_4S	TIORH_4S	8	H'FFFFFFC606		8, 16		
Timer I/O control register L_4S	TIORL_4S	8	H'FFFFFFC607		8		
Timer interrupt enable register_3S	TIER_3S	8	H'FFFFFFC608		8, 16		
Timer interrupt enable register_4S	TIER_4S	8	H'FFFFFFC609		8		
Timer output master enable register S	TOERS	8	H'FFFFFFC60A		8		
Timer gate control register S	TGCRS	8	H'FFFFFFC60D		8		
Timer output control register 1S	TOCR1S	8	H'FFFFFFC60E		8, 16		
Timer output control register 2S	TOCR2S	8	H'FFFFFFC60F		8		
Timer counter_3S	TCNT_3S	16	H'FFFFFFC610		16, 32		
Timer counter_4S	TCNT_4S	16	H'FFFFFFC612		16		
Timer cycle data register S	TCDRS	16	H'FFFFFFC614		16, 32		
Timer dead time data register S	TDDRS	16	H'FFFFFFC616		16		
Timer general register A_3S	TGRA_3S	16	H'FFFFFFC618		16, 32		
Timer general register B_3S	TGRB_3S	16	H'FFFFFFC61A		16		
Timer general register A_4S	TGRA_4S	16	H'FFFFFFC61C		16, 32		

Register Name	Abbreviation	No. of		Module	Access Size	No. of Access States	Connected Bus Width
		Bits	Address				
Timer general register B_4S	TGRB_4S	16	H'FFFFFF61E	MTU2S	16	M ϕ reference	16 bits
Timer sub-counter S	TCNTSS	16	H'FFFFFF620		16, 32	B:2	
Timer cycle buffer register S	TCBRS	16	H'FFFFFF622		16	W:2	
Timer general register C_3S	TGRC_3S	16	H'FFFFFF624		16, 32	L:4	
Timer general register D_3S	TGRD_3S	16	H'FFFFFF626		16		
Timer general register C_4S	TGRC_4S	16	H'FFFFFF628		16, 32		
Timer general register D_4S	TGRD_4S	16	H'FFFFFF62A		16		
Timer status register_3S	TSR_3S	8	H'FFFFFF62C		8, 16		
Timer status register_4S	TSR_4S	8	H'FFFFFF62D		8		
Timer interrupt skipping set register S	TITCRS	8	H'FFFFFF630		8, 16		
Timer interrupt skipping counter S	TITCNTS	8	H'FFFFFF631		8		
Timer buffer transfer set register S	TBTERS	8	H'FFFFFF632		8		
Timer dead time enable register S	TDERS	8	H'FFFFFF634		8		
Timer output level buffer register S	TOLBRS	8	H'FFFFFF636		8		
Timer buffer operation transfer mode register_3S	TBTM_3S	8	H'FFFFFF638		8, 16		
Timer buffer operation transfer mode register_4S	TBTM_4S	8	H'FFFFFF639		8		
Timer A/D converter start request control register S	TADCRS	16	H'FFFFFF640		16		
Timer A/D converter start request cycle set register A_4S	TADCORA_4S	16	H'FFFFFF644		16, 32		
Timer A/D converter start request cycle set register B_4S	TADCORB_4S	16	H'FFFFFF646		16		
Timer A/D converter start request cycle set buffer register A_4S	TADCOBRA_4S	16	H'FFFFFF648		16, 32		
Timer A/D converter start request cycle set buffer register B_4S	TADCOBRB_4S	16	H'FFFFFF64A		16		
Timer synchronous clear register S	TSYCRS	8	H'FFFFFF650		8		
Timer waveform control register S	TWCERS	8	H'FFFFFF660		8		
Timer start register S	TSTRS	8	H'FFFFFF680		8, 16		
Timer synchronous register S	TSYRS	8	H'FFFFFF681		8		
Timer read/write enable register S	TRWERS	8	H'FFFFFF684		8		

Register Name	Abbreviation	No. of		Module	Access Size	No. of Access States	Connected Bus Width
		Bits	Address				
Timer counter U_5S	TCNTU_5S	16	H'FFFFFFC880	MTU2S	16, 32	M ϕ reference	16 bits
Timer general register U_5S	TGRU_5S	16	H'FFFFFFC882		16	B:2	
Timer control register U_5S	TCRU_5S	8	H'FFFFFFC884		8	W:2	
Timer I/O control register U_5S	TIORU_5S	8	H'FFFFFFC886		8	L:4	
Timer counter V_5S	TCNTV_5S	16	H'FFFFFFC890		16, 32		
Timer general register V_5S	TGRV_5S	16	H'FFFFFFC892		16		
Timer control register V_5S	TCRV_5S	8	H'FFFFFFC894		8		
Timer I/O control register V_5S	TIORV_5S	8	H'FFFFFFC896		8		
Timer counter W_5S	TCNTW_5S	16	H'FFFFFFC8A0		16, 32		
Timer general register W_5S	TGRW_5S	16	H'FFFFFFC8A2		16		
Timer control register W_5S	TCRW_5S	8	H'FFFFFFC8A4		8		
Timer I/O control register W_5S	TIORW_5S	8	H'FFFFFFC8A6		8		
Timer status register_5S	TSR_5S	8	H'FFFFFFC8B0		8		
Timer interrupt enable register_5S	TIER_5S	8	H'FFFFFFC8B2		8		
Timer start register_5S	TSTR_5S	8	H'FFFFFFC8B4		8		
Timer compare match clear register S	TCNTCMPCLRS	8	H'FFFFFFC8B6		8		
A/D data register 0	ADDR0	16	H'FFFFFFC900	A/D	16	P ϕ reference	16 bits
A/D data register 2	ADDR2	16	H'FFFFFFC904	(Channel 0)	16	B:2	
A/D control/status register_0	ADCSR_0	16	H'FFFFFFC910		16	W:2	
A/D control register_0	ADCR_0	16	H'FFFFFFC912		16		
A/D data register 4	ADDR4	16	H'FFFFFFC980	A/D	16	P ϕ reference	16 bits
A/D data register 6	ADDR6	16	H'FFFFFFC984	(Channel 1)	16	B:2	
A/D control/status register_1	ADCSR_1	16	H'FFFFFFC990		16	W:2	
A/D control register_1	ADCR_1	16	H'FFFFFFC992		16		
A/D data register 8	ADDR8	16	H'FFFFFFCA00	A/D	16	P ϕ reference	16 bits
A/D data register 9	ADDR9	16	H'FFFFFFCA02	(Channel 2)	16	B:2	
A/D data register 10	ADDR10	16	H'FFFFFFCA04		16	W:2	
A/D data register 11	ADDR11	16	H'FFFFFFCA06		16		
A/D data register 12	ADDR12	16	H'FFFFFFCA08		16		
A/D data register 13	ADDR13	16	H'FFFFFFCA0A		16		
A/D data register 14	ADDR14	16	H'FFFFFFCA0C		16		

Register Name	Abbreviation	No. of		Module	Access Size	No. of Access States	Connected Bus Width
		Bits	Address				
A/D data register 15	ADDR15	16	H'FFFCA0E	A/D	16	Pφ reference	16 bits
A/D control/status register_2	ADCSR_2	16	H'FFFCA10	(Channel 2)	16	B:2	
A/D control register_2	ADCR_2	16	H'FFFCA12		16	W:2	
Flash code control/status register	FCCS	8	H'FFFCC00	FLASH	8	Pφ reference	16 bits
Flash program code select register	FPCS	8	H'FFFCC01	(Only in	8	B:5	
Flash erase code select register	FECS	8	H'FFFCC02	F-ZTAT	8		
Flash key code register	FKEY	8	H'FFFCC04	version)	8		
Flash MAT select register	FMATS	8	H'FFFCC05		8		
Flash transfer destination address register	FTDAR	8	H'FFFCC06		8		
DTC enable register A	DTCERA	16	H'FFFCC80	DTC	8, 16	Pφ reference	16 bits
DTC enable register B	DTCERB	16	H'FFFCC82	(Only in	8, 16	B:2	
DTC enable register C	DTCERC	16	H'FFFCC84	F-ZTAT	8, 16	W:2	
DTC enable register D	DTCERD	16	H'FFFCC86	version)	8, 16	L:4	
DTC enable register E	DTCERE	16	H'FFFCC88		8, 16		
DTC control register	DTCCR	8	H'FFFCC90		8		
DTC vector base register	DTCVBR	32	H'FFFCC94		8, 16, 32		
Compare match timer start register	CMSTR	16	H'FFFCE00	CMT	8, 16, 32	Pφ reference	16 bits
Compare match timer control/status register_0	CMCSR_0	16	H'FFFCE02		8, 16	B:2	
Compare match counter_0	CMCNT_0	16	H'FFFCE04		8, 16, 32	L:4	
Compare match constant register_0	CMCOR_0	16	H'FFFCE06		8, 16		
Compare match timer control/status register_1	CMCSR_1	16	H'FFFCE08		8, 16, 32		
Compare match counter_1	CMCNT_1	16	H'FFFCE0A		8, 16		
Compare match constant register_1	CMCOR_1	16	H'FFFCE0C		8, 16, 32		
Input level control/status register 1	ICSR1	16	H'FFFDD000	POE	8, 16, 32	Pφ reference	16 bits
Output level control/status register 1	OCSR1	16	H'FFFDD002		8, 16	B:2	
Input level control/status register 2	ICSR2	16	H'FFFDD004		8, 16, 32	W:2	
Output level control/status register 2	OCSR2	16	H'FFFDD006		8, 16	L:4	

Register Name	Abbreviation	No. of		Module	Access Size	No. of Access States	Connected Bus Width
		Bits	Address				
Input level control/status register 3	ICSR3	16	H'FFFFD008	POE	8, 16	P ϕ reference	16 bits
Software port output enable register	SPOER	8	H'FFFFD00A		8	B:2	
Port output enable control register 1	POECR1	8	H'FFFFD00B		8	W:2	
Port output enable control register 2	POECR2	16	H'FFFFD00C		8, 16	L:4	
Port A data register L	PADRL	16	H'FFFFD102	I/O	8, 16	P ϕ reference	16 bits
Port A I/O register L	PAIORL	16	H'FFFFD106	PFC	8, 16	B:2	
Port A control register L4	PACRL4	16	H'FFFFD110		8, 16, 32	W:2	
Port A control register L3	PACRL3	16	H'FFFFD112		8, 16	L:4	
Port A control register L2	PACRL2	16	H'FFFFD114		8, 16, 32		
Port A control register L1	PACRL1	16	H'FFFFD116		8, 16		
Port A port register L	PAPRL	16	H'FFFFD11E	I/O	8, 16		
Port B data register H	PBDRH	16	H'FFFFD180		8, 16, 32		
Port B data register L	PBDRL	16	H'FFFFD182		8, 16		
Port B I/O register H	PBIORH	16	H'FFFFD184	PFC	8, 16, 32		
Port B I/O register L	PBIORL	16	H'FFFFD186		8, 16		
Port B control register H1	PBCRH1	16	H'FFFFD18E		8, 16		
Port B control register L2	PBCRL2	16	H'FFFFD194		8, 16, 32		
Port B control register L1	PBCRL1	16	H'FFFFD196		8, 16		
Port B port register H	PBPRH	16	H'FFFFD19C	I/O	8, 16, 32		
Port B port register L	PBPRL	16	H'FFFFD19E		8, 16		
Port D data register L* ¹	PDDRLL	16	H'FFFFD282		8, 16		
Port D I/O register L* ¹	PDIORL	16	H'FFFFD286	PFC	8, 16		
Port D control register L4* ¹	PDCRL4	16	H'FFFFD290		8, 16, 32		
Port D control register L3* ¹	PDCRL3	16	H'FFFFD292		8, 16		
Port D control register L2* ¹	PDCRL2	16	H'FFFFD294		8, 16, 32		
Port D control register L1* ¹	PDCRL1	16	H'FFFFD296		8, 16		
Port D port register L* ¹	PDPRL	16	H'FFFFD29E	I/O	8, 16		
Port E data register H	PEDRH	16	H'FFFFD300		8, 16, 32		
Port E data register L	PEDRL	16	H'FFFFD302		8, 16		
Port E I/O register H	PEIORH	16	H'FFFFD304	PFC	8, 16, 32		
Port E I/O register L	PEIORL	16	H'FFFFD306		8, 16		

Register Name	Abbreviation	No. of		Module	Access Size	No. of Access States	Connected Bus Width
		Bits	Address				
Port E control register H2	PECRH2	16	H'FFFFFFD30C	PFC	8, 16, 32	Pφ reference	16 bits
Port E control register H1	PECRH1	16	H'FFFFFFD30E		8, 16	B:2	
Port E control register L4	PECRL4	16	H'FFFFFFD310		8, 16, 32	W:2	
Port E control register L3	PECRL3	16	H'FFFFFFD312		8, 16	L:4	
Port E control register L2	PECRL2	16	H'FFFFFFD314		8, 16, 32		
Port E control register L1	PECRL1	16	H'FFFFFFD316		8, 16		
Port E port register H	PEPRH	16	H'FFFFFFD31C	I/O	8, 16, 32		
Port E port register L	PEPRL	16	H'FFFFFFD31E		8, 16		
IRQOUT function control register	IFCR	16	H'FFFFFFD322	PFC	8, 16		
Port F data register L	PFDRL	16	H'FFFFFFD382	I/O	8, 16		
Frequency control register	FRQCR	16	H'FFFFFFE800	CPG	16	Pφ reference W:2	16 bits
Standby control register 1	STBCR1	8	H'FFFFFFE802	Power-down modes	8	Pφ reference	16 bits
Standby control register 2	STBCR2	8	H'FFFFFFE804		8	B:2	
Standby control register 3	STBCR3	8	H'FFFFFFE806		8		
Standby control register 4	STBCR4	8	H'FFFFFFE808		8		
Standby control register 5	STBCR5	8	H'FFFFFFE80A		8		
Standby control register 6	STBCR6	8	H'FFFFFFE80C		8		
Watchdog timer counter	WTCNT	8	H'FFFFFFE810	WDT	8* ¹ , 16* ²	Pφ reference	16 bits
Watchdog timer control/status register	WTCSR	8	H'FFFFFFE812	*1: Read *2: Write	8* ¹ , 16* ²	B:2* ¹ W:2* ²	
Oscillation stop detection control register	OSCCR	8	H'FFFFFFE814	CPG	8	Pφ reference B:2	16 bits
RAM control register	RAMCR	8	H'FFFFFFE880	Power-down modes	8	Pφ reference B:2	16 bits
A/D trigger select register 0	ADTSR_0	16	H'FFFFFFE890	A/D	8, 16	Pφ reference	16 bits
A/D trigger select register 1	ADTSR_1	16	H'FFFFFFE892		8, 16	B:2 W:2	
Bus function extending register	BSCEHR	16	H'FFFFFFE89A	BSC	8, 16	Pφ reference B:2 W:2	16 bits

Register Name	Abbreviation	No. of		Module	Access Size	No. of Access States	Connected Bus Width
		Bits	Address				
Interrupt control register 0	ICR0	16	H'FFFFFF900	INTC	8, 16	P ϕ reference	16 bits
IRQ control register	IRQCR	16	H'FFFFFF902		8, 16	B:2	
IRQ status register	IRQSR	16	H'FFFFFF904		8, 16	W:2	
Interrupt priority register A	IPRA	16	H'FFFFFF906		8, 16		
Interrupt priority register D	IPRD	16	H'FFFFFF982		16		
Interrupt priority register E	IPRE	16	H'FFFFFF984		16		
Interrupt priority register F	IPRF	16	H'FFFFFF986		16		
Interrupt priority register H	IPRH	16	H'FFFFFF98A		16		
Interrupt priority register I	IPRI	16	H'FFFFFF98C		16		
Interrupt priority register J	IPRJ	16	H'FFFFFF98E		16		
Interrupt priority register K	IPRK	16	H'FFFFFF990		16		
Interrupt priority register L	IPRL	16	H'FFFFFF992		16		
Common control register	CMNCR	32	H'FFFFFF000	BSC	32	B ϕ reference	16 bits
CS0 space bus control register	CS0BCR	32	H'FFFFFF004		32	L:2	
CS1 space bus control register	CS1BCR	32	H'FFFFFF008		32		
CS0 space wait control register	CS0WCR	32	H'FFFFFF028		32		
CS1 space wait control register	CS1WCR	32	H'FFFFFF02C		32		
RAM emulation register	RAMER	16	H'FFFFFF108	FLASH (Only in F-ZTAT version)	16	B ϕ reference W:2	16 bits
Break address register A	BARA	32	H'FFFFFF300	UBC	32	B ϕ reference	16 bits
Break address mask register A	BAMRA	32	H'FFFFFF304		32	B:2	
Break bus cycle register A	BBRA	16	H'FFFFFF308		16	W:2	
Break data register A ^{*2}	BDRA	32	H'FFFFFF310		32	L:2	
Break data mask register A ^{*2}	BDMRA	32	H'FFFFFF314		32		
Break address register B	BARB	32	H'FFFFFF320		32		
Break address mask register B	BAMRB	32	H'FFFFFF324		32		
Break bus cycle register B	BBRB	16	H'FFFFFF328		16		
Break data register B ^{*2}	BDRB	32	H'FFFFFF330		32		
Break data mask register B ^{*2}	BDMRB	32	H'FFFFFF334		32		

Register Name	Abbreviation	No. of		Module	Access Size	No. of Access States	Connected Bus Width
		Bits	Address				
Break control register	BRCR	32	H'FFFFFF3C0	UBC	32	B ϕ reference	16 bits
Branch source register* ²	BRSR	32	H'FFFFFF3D0		32	B:2	
Branch destination register* ²	BRDR	32	H'FFFFFF3D4		32	W:2	
Execution times break register* ²	BETR	16	H'FFFFFF3DC		16	L:2	

Notes: 1. Only SH7149.
2. Only in F-ZTAT version.

23.2 Register Bit List

Addresses and bit names of each on-chip peripheral module are shown below.

As for 16-bit or 32-bit registers, they are shown in two or four rows.

Register Abbreviation	Bit 31/23/15/7	Bit 30/22/14/6	Bit 29/21/13/5	Bit 28/20/12/4	Bit 27/19/11/3	Bit 26/18/10/2	Bit 25/17/9/1	Bit 24/16/8/0	Module
SCSMR_0	C/ \bar{A}	CHR	PE	O/ \bar{E}	STOP	MP	CKS[1:0]		SCI (Channel 0)
SCBRR_0									
SCSCR_0	TIE	RIE	TE	RE	MPIE	TEIE	CKE[1:0]		
SCTDR_0									
SCSSR_0	TDRE	RDRF	ORER	FER	PER	TEND	MPB	MPBT	
SCRDR_0									
SCSDCR_0	—	—	—	—	DIR	—	—	—	
SCSPTR_0	EIO	—	—	—	SPB1IO	SPB1DT	SPB0IO	SPB0DT	
SCSMR_1	C/ \bar{A}	CHR	PE	O/ \bar{E}	STOP	MP	CKS[1:0]		SCI (Channel 1)
SCBRR_1									
SCSCR_1	TIE	RIE	TE	RE	MPIE	TEIE	CKE[1:0]		
SCTDR_1									
SCSSR_1	TDRE	RDRF	ORER	FER	PER	TEND	MPB	MPBT	
SCRDR_1									
SCSDCR_1	—	—	—	—	DIR	—	—	—	
SCSPTR_1	EIO	—	—	—	SPB1IO	SPB1DT	SPB0IO	SPB0DT	
SCSMR_2	C/ \bar{A}	CHR	PE	O/ \bar{E}	STOP	MP	CKS[1:0]		SCI (Channel 2)
SCBRR_2									
SCSCR_2	TIE	RIE	TE	RE	MPIE	TEIE	CKE[1:0]		
SCTDR_2									
SCSSR_2	TDRE	RDRF	ORER	FER	PER	TEND	MPB	MPBT	
SCRDR_2									
SCSDCR_2	—	—	—	—	DIR	—	—	—	
SCSPTR_2	EIO	—	—	—	SPB1IO	SPB1DT	SPB0IO	SPB0DT	

Register Abbreviation	Bit 31/23/15/7	Bit 30/22/14/6	Bit 29/21/13/5	Bit 28/20/12/4	Bit 27/19/11/3	Bit 26/18/10/2	Bit 25/17/9/1	Bit 24/16/8/0	Module
TCR_3	CCLR[2:0]			CKEG[1:0]		TPSC[2:0]			MTU2
TCR_4	CCLR[2:0]			CKEG[1:0]		TPSC[2:0]			
TMDR_3	—	—	BFB	BFA	MD[3:0]				
TMDR_4	—	—	BFB	BFA	MD[3:0]				
TIORH_3	IOB[3:0]				IOA[3:0]				
TIORL_3	IOD[3:0]				IOC[3:0]				
TIORH_4	IOB[3:0]				IOA[3:0]				
TIORL_4	IOD[3:0]				IOC[3:0]				
TIER_3	TTGE	—	—	TCIEV	TGIED	TGIEC	TGIEB	TGIEA	
TIER_4	TTGE	TTGE2	—	TCIEV	TGIED	TGIEC	TGIEB	TGIEA	
TOER	—	—	OE4D	OE4C	OE3D	OE4B	OE4A	OE3B	
TGCR	—	BDC	N	P	FB	WF	VF	UF	
TOCR1	—	PSYE	—	—	TOCL	TOCS	OLSN	OLSP	
TOCR2	BF[1:0]		OLS3N	OLS3P	OLS2N	OLS2P	OLS1N	OLS1P	
TCNT_3									
TCNT_4									
TCDR									
TDDR									
TGRA_3									
TGRB_3									
TGRA_4									
TGRB_4									

Register Abbreviation	Bit 31/23/15/7	Bit 30/22/14/6	Bit 29/21/13/5	Bit 28/20/12/4	Bit 27/19/11/3	Bit 26/18/10/2	Bit 25/17/9/1	Bit 24/16/8/0	Module
TCNTS									MTU2
TCBR									
TGRC_3									
TGRD_3									
TGRC_4									
TGRD_4									
TSR_3	TCFD	—	—	TCFV	TGFD	TGFC	TGFB	TGFA	
TSR_4	TCFD	—	—	TCFV	TGFD	TGFC	TGFB	TGFA	
TITCR	T3AEN	3ACOR[2:0]			T4VEN	4VCOR[2:0]			
TITCNT	—	3ACNT[2:0]			—	4VCNT[2:0]			
TBTER	—	—	—	—	—	—	BTE[1:0]		
TDER	—	—	—	—	—	—	—	TDER	
TOLBR	—	—	OLS3N	OLS3P	OLS2N	OLS2P	OLS1N	OLS1P	
TBTM_3	—	—	—	—	—	—	TTSB	TTSA	
TBTM_4	—	—	—	—	—	—	TTSB	TTSA	
TADCR	BF[1:0]		—	—	—	—	—	—	
	UT4AE	DT4AE	UT4BE	DT4BE	ITA3AE	ITA4VE	ITB3AE	ITB4VE	
TADCORA_4									
TADCORB_4									
TADCOBRA_4									
TADCOBRB_4									

Register Abbreviation	Bit 31/23/15/7	Bit 30/22/14/6	Bit 29/21/13/5	Bit 28/20/12/4	Bit 27/19/11/3	Bit 26/18/10/2	Bit 25/17/9/1	Bit 24/16/8/0	Module
TWCR	CCE	—	—	—	—	—	—	WRE	MTU2
TSTR	CST4	CST3	—	—	—	CST2	CST1	CST0	
TSYR	SYNC4	SYNC3	—	—	—	SYNC2	SYNC1	SYNC0	
TCSYSTR	SCH0	SCH1	SCH2	SCH3	SCH4	—	SCH3S	SCH4S	
TRWER	—	—	—	—	—	—	—	RWE	
TCR_0	CCLR[2:0]			CKEG[1:0]		TPSC[2:0]			
TMDR_0	—	BFE	BFB	BFA	MD[3:0]				
TIORH_0	IOB[3:0]				IOA[3:0]				
TIORL_0	IOD[3:0]				IOC[3:0]				
TIER_0	TTGE	—	—	TCIEV	TGIED	TGIEC	TGIEB	TGIEA	
TSR_0	—	—	—	TCFV	TGFD	TGFC	TGFB	TGFA	
TCNT_0									
TGRA_0									
TGRB_0									
TGRC_0									
TGRD_0									
TGRE_0									
TGRF_0									
TIER2_0	TTGE2	—	—	—	—	—	TGIEF	TGIEE	
TSR2_0	—	—	—	—	—	—	TGFF	TGFE	
TBTM_0	—	—	—	—	—	TTSE	TTSB	TTSA	
TCR_1	—	CCLR[1:0]		CKEG[1:0]		TPSC[2:0]			
TMDR_1	—	—	—	—	MD[3:0]				
TIOR_1	IOB[3:0]				IOA[3:0]				

Register Abbreviation	Bit 31/23/15/7	Bit 30/22/14/6	Bit 29/21/13/5	Bit 28/20/12/4	Bit 27/19/11/3	Bit 26/18/10/2	Bit 25/17/9/1	Bit 24/16/8/0	Module	
TIER_1	TTGE	—	TCIEU	TCIEV	—	—	TGIEB	TGIEA	MTU2	
TSR_1	TCFD	—	TCFU	TCFV	—	—	TGFB	TGFA		
TCNT_1										
TGRA_1										
TGRB_1										
TICCR	—	—	—	—	I2BE	I2AE	I1BE	I1AE		
TCR_2	—	CCLR[1:0]		CKEG[1:0]		TPSC[2:0]				
TMDR_2	—	—	—	—	MD[3:0]					
TIOR_2	IOB[3:0]				IOA[3:0]					
TIER_2	TTGE	—	TCIEU	TCIEV	—	—	TGIEB	TGIEA		
TSR_2	TCFD	—	TCFU	TCFV	—	—	TGFB	TGFA		
TCNT_2										
TGRA_2										
TGRB_2										
TCNTU_5										
TGRU_5										
TCRU_5	—	—	—	—	—	—	TPSC[1:0]			
TIORU_5	—	—	—	IOC[4:0]						
TCNTV_5										
TGRV_5										

Register Abbreviation	Bit 31/23/15/7	Bit 30/22/14/6	Bit 29/21/13/5	Bit 28/20/12/4	Bit 27/19/11/3	Bit 26/18/10/2	Bit 25/17/9/1	Bit 24/16/8/0	Module	
TCRV_5	—	—	—	—	—	—	TPSC[1:0]		MTU2	
TIORV_5	—	—	—	IOC[4:0]						
TCNTW_5										
TGRW_5										
TCRW_5	—	—	—	—	—	—	TPSC[1:0]			
TIORW_5	—	—	—	IOC[4:0]						
TSR_5	—	—	—	—	—	CMFU5	CMFV5	CMFW5		
TIER_5	—	—	—	—	—	TGIE5U	TGIE5V	TGIE5W		
TSTR_5	—	—	—	—	—	CSTU5	CSTV5	CSTW5		
TCNTCMPCLR	—	—	—	—	—	CMPCLR5U	CMPCLR5V	CMPCLR5W		
TCR_3S	CCLR[2:0]			CKEG[1:0]		TPSC[2:0]				MTU2S
TCR_4S	CCLR[2:0]			CKEG[1:0]		TPSC[2:0]				
TMDR_3S	—	—	BFB	BFA	MD[3:0]					
TMDR_4S	—	—	BFB	BFA	MD[3:0]					
TIORH_3S	IOB[3:0]				IOA[3:0]					
TIORL_3S	IOD[3:0]				IOC[3:0]					
TIORH_4S	IOB[3:0]				IOA[3:0]					
TIORL_4S	IOD[3:0]				IOC[3:0]					
TIER_3S	TTGE	—	—	TCIEV	TGIED	TGIEC	TGIEB	TGIEA		
TIER_4S	TTGE	TTGE2	—	TCIEV	TGIED	TGIEC	TGIEB	TGIEA		
TOERS	—	—	OE4D	OE4C	OE3D	OE4B	OE4A	OE3B		
TGCRS	—	BDC	N	P	FB	WF	VF	UF		
TOCR1S	—	PSYE	—	—	TOCL	TOCS	OLSN	OLSP		
TOCR2S	BF[1:0]		OLS3N	OLS3P	OLS2N	OLS2P	OLS1N	OLS1P		
TCNT_3S										
TCNT_4S										

Register Abbreviation	Bit 31/23/15/7	Bit 30/22/14/6	Bit 29/21/13/5	Bit 28/20/12/4	Bit 27/19/11/3	Bit 26/18/10/2	Bit 25/17/9/1	Bit 24/16/8/0	Module
TCDRS									MTU2S
TDDRS									
TGRA_3S									
TGRB_3S									
TGRA_4S									
TGRB_4S									
TCNTSS									
TCBRS									
TGRC_3S									
TGRD_3S									
TGRC_4S									
TGRD_4S									
TSR_3S	TCFD	—	—	TCFV	TGFD	TGFC	TGFB	TGFA	
TSR_4S	TCFD	—	—	TCFV	TGFD	TGFC	TGFB	TGFA	
TITCRS	T3AEN	3ACOR[2:0]			T4VEN	4VCOR[2:0]			
TITCNTS	—	3ACNT[2:0]			—	4VCNT[2:0]			
TBTERS	—	—	—	—	—	—	BTE[1:0]		
TDERS	—	—	—	—	—	—	—	TDER	
TOLBRS	—	—	OLS3N	OLS3P	OLS2N	OLS2P	OLS1N	OLS1P	

Register Abbreviation	Bit 31/23/15/7	Bit 30/22/14/6	Bit 29/21/13/5	Bit 28/20/12/4	Bit 27/19/11/3	Bit 26/18/10/2	Bit 25/17/9/1	Bit 24/16/8/0	Module	
TBTM_3S	—	—	—	—	—	—	TTSB	T TSA	MTU2S	
TBTM_4S	—	—	—	—	—	—	TTSB	T TSA		
TADCRS	BF[1:0]		—	—	—	—	—	—		
	UT4AE	DT4AE	UT4BE	DT4BE	ITA3AE	ITA4VE	ITB3AE	ITB4VE		
TADCORA_4S										
TADCORB_4S										
TADCOBRA_4S										
TADCOBRB_4S										
TSYCRS	CE0A	CE0B	CE0C	CE0D	CE1A	CE1B	CE2A	CE2B		
TWCRS	CCE	—	—	—	—	—	SCC	WRE		
TSTRS	CST4	CST3	—	—	—	CST2	CST1	CST0		
TSYRS	SYNC4	SYNC3	—	—	—	SYNC2	SYNC1	SYNC0		
TRWERS	—	—	—	—	—	—	—	RWE		
TCNTU_5S										
TGRU_5S										
TCRU_5S	—	—	—	—	—	—	TPSC[1:0]			
TIORU_5S	—	—	—	IOC[4:0]						
TCNTV_5S										
TGRV_5S										
TCRV_5S	—	—	—	—	—	—	TPSC[1:0]			
TIORV_5S	—	—	—	IOC[4:0]						

Register Abbreviation	Bit 31/23/15/7	Bit 30/22/14/6	Bit 29/21/13/5	Bit 28/20/12/4	Bit 27/19/11/3	Bit 26/18/10/2	Bit 25/17/9/1	Bit 24/16/8/0	Module	
TCNTW_5S									MTU2S	
TGRW_5S										
TCRW_5S	—	—	—	—	—	—	TPSC[1:0]			
TIORW_5S	—	—	—	IOC[4:0]						
TSR_5S	—	—	—	—	—	CMFU5	CMFV5	CMFW5		
TIER_5S	—	—	—	—	—	TGIE5U	TGIE5V	TGIE5W		
TSTR_5S	—	—	—	—	—	CSTU5	CSTV5	CSTW5		
TCNTCMPCLRS	—	—	—	—	—	CMPCLR5U	CMPCLR5V	CMPCLR5W		
ADDR0	AD9	AD8	AD7	AD6	AD5	AD4	AD3	AD2		A/D (Channel 0)
	AD1	AD0	—	—	—	—	—	—		
ADDR2	AD9	AD8	AD7	AD6	AD5	AD4	AD3	AD2		
	AD1	AD0	—	—	—	—	—	—		
ADCSR_0	ADF	ADIE	—	—	TRGE	—	CONADF	STC		
	CKSL[1:0]		ADM[1:0]		ADCS	CH[2:0]				
ADCR_0	—	—	ADST	—	—	—	—	—		
	—	—	—	—	—	—	—	—		
ADDR4	AD9	AD8	AD7	AD6	AD5	AD4	AD3	AD2	A/D (Channel 1)	
	AD1	AD0	—	—	—	—	—	—		
ADDR6	AD9	AD8	AD7	AD6	AD5	AD4	AD3	AD2		
	AD1	AD0	—	—	—	—	—	—		
ADCSR_1	ADF	ADIE	—	—	TRGE	—	CONADF	STC		
	CKSL[1:0]		ADM[1:0]		ADCS	CH[2:0]				
ADCR_1	—	—	ADST	—	—	—	—	—		
	—	—	—	—	—	—	—	—		
ADDR8	AD9	AD8	AD7	AD6	AD5	AD4	AD3	AD2		A/D (Channel 2)
	AD1	AD0	—	—	—	—	—	—		
ADDR9	AD9	AD8	AD7	AD6	AD5	AD4	AD3	AD2		
	AD1	AD0	—	—	—	—	—	—		

Register Abbreviation	Bit 31/23/15/7	Bit 30/22/14/6	Bit 29/21/13/5	Bit 28/20/12/4	Bit 27/19/11/3	Bit 26/18/10/2	Bit 25/17/9/1	Bit 24/16/8/0	Module
ADDR10	AD9	AD8	AD7	AD6	AD5	AD4	AD3	AD2	A/D (Channel 2)
	AD1	AD0	—	—	—	—	—	—	
ADDR11	AD9	AD8	AD7	AD6	AD5	AD4	AD3	AD2	
	AD1	AD0	—	—	—	—	—	—	
ADDR12	AD9	AD8	AD7	AD6	AD5	AD4	AD3	AD2	
	AD1	AD0	—	—	—	—	—	—	
ADDR13	AD9	AD8	AD7	AD6	AD5	AD4	AD3	AD2	
	AD1	AD0	—	—	—	—	—	—	
ADDR14	AD9	AD8	AD7	AD6	AD5	AD4	AD3	AD2	
	AD1	AD0	—	—	—	—	—	—	
ADDR15	AD9	AD8	AD7	AD6	AD5	AD4	AD3	AD2	
	AD1	AD0	—	—	—	—	—	—	
ADCSR_2	ADF	ADIE	—	—	TRGE	—	CONADF	STC	
	CKSL[1:0]		ADM[1:0]		ADCS	CH[2:0]			
ADCR_2	—	—	ADST	—	—	—	—	—	
	—	—	—	—	—	—	—	—	
FCCS	FWE	MAT	—	FLER	—	—	—	SCO	FLASH (Only in F-ZTAT version)
FPCS	—	—	—	—	—	—	—	PPVS	
FECS	—	—	—	—	—	—	—	EPVB	
FKEY	K[7:0]								
FMATS	MS7	MS6	MS5	MS4	MS3	MS2	MS1	MS0	
FTDAR	TDER	TDA[6:0]							
DTCERA	DTCERA15	DTCERA14	DTCERA13	DTCERA12	—	—	—	—	DTC (Only in F-ZTAT version)
	—	—	—	—	—	—	—	—	
DTCERB	DTCERB15	DTCERB14	DTCERB13	DTCERB12	DTCERB11	DTCERB10	DTCERB9	DTCERB8	
	DTCERB7	DTCERB6	DTCERB5	DTCERB4	DTCERB3	DTCERB2	DTCERB1	DTCERB0	
DTCERC	DTCERC15	DTCERC14	DTCERC13	DTCERC12	—	—	—	—	
	—	—	—	—	DTCERC3	DTCERC2	DTCERC1	DTCERC0	
DTCERD	DTCERD15	DTCERD14	DTCERD13	DTCERD12	DTCERD11	DTCERD10	DTCERD9	DTCERD8	
	DTCERD7	DTCERD6	DTCERD5	DTCERD4	DTCERD3	—	—	—	

Register Abbreviation	Bit 31/23/15/7	Bit 30/22/14/6	Bit 29/21/13/5	Bit 28/20/12/4	Bit 27/19/11/3	Bit 26/18/10/2	Bit 25/17/9/1	Bit 24/16/8/0	Module	
DTCERE	DTCERE15	DTCERE14	DTCERE13	DTCERE12	DTCERE11	DTCERE10	—	—	DTC (Only in F-ZTAT version)	
	—	—	—	—	—	—	—	—		
DTCCR	—	—	—	RRS	RCHNE	—	—	ERR		
DTCVBR										
					—	—	—	—		
	—	—	—	—	—	—	—	—		
CMSTR	—	—	—	—	—	—	—	—		CMT
	—	—	—	—	—	—	STR1	STR0		
CMCSR_0	—	—	—	—	—	—	—	—		
	CMF	CMIE	—	—	—	—	CKS[1:0]			
CMCNT_0										
CMCOR_0										
CMCSR_1	—	—	—	—	—	—	—	—		
	CMF	CMIE	—	—	—	—	CKS[1:0]			
CMCNT_1										
CMCOR_1										
ICSR1	POE3F	POE2F	POE1F	POE0F	—	—	—	PIE1	POE	
	POE3M[1:0]		POE2M[1:0]		POE1M[1:0]		POE0M[1:0]			
OCSR1	OSF1	—	—	—	—	—	OCE1	OIE1		
	—	—	—	—	—	—	—	—		
ICSR2	POE7F	POE6F	POE5F	POE4F	—	—	—	PIE2		
	POE7M[1:0]		POE6M[1:0]		POE5M[1:0]		POE4M[1:0]			
OCSR2	OSF2	—	—	—	—	—	OCE2	OIE2		
	—	—	—	—	—	—	—	—		
ICSR3	—	—	—	POE8F	—	—	POE8E	PIE3		
	—	—	—	—	—	—	POE8M[1:0]			

Register Abbreviation	Bit 31/23/15/7	Bit 30/22/14/6	Bit 29/21/13/5	Bit 28/20/12/4	Bit 27/19/11/3	Bit 26/18/10/2	Bit 25/17/9/1	Bit 24/16/8/0	Module
SPOER	—	—	—	—	—	MTU2SHIZ	MTU2CH0HIZ	MTU2CH34HIZ	POE
POECR1	—	—	—	—	MTU2PE3ZE	MTU2PE2ZE	MTU2PE1ZE	MTU2PE0ZE	
POECR2	—	MTU2P1CZE	MTU2P2CZE	MTU2P3CZE	—	MTU2SP1CZE	MTU2SP2CZE	MTU2SP3CZE	
PADRL	PA15DR	PA14DR	PA13DR	PA12DR	PA11DR	PA10DR	PA9DR	PA8DR	I/O
	PA7DR	PA6DR	PA5DR	PA4DR	PA3DR	PA2DR	PA1DR	PA0DR	
PAIORL	PA15IOR	PA14IOR	PA13IOR	PA12IOR	PA11IOR	PA10IOR	PA9IOR	PA8IOR	PFC
	PA7IOR	PA6IOR	PA5IOR	PA4IOR	PA3IOR	PA2IOR	PA1IOR	PA0IOR	
PACRL4	—	PA15MD2	PA15MD1	PA15MD0	—	PA14MD2	PA14MD1	PA14MD0	
	—	PA13MD2	PA13MD1	PA13MD0	—	PA12MD2	PA12MD1	PA12MD0	
PACRL3	—	PA11MD2	PA11MD1	PA11MD0	—	PA10MD2	PA10MD1	PA10MD0	
	—	PA9MD2	PA9MD1	PA9MD0	—	PA8MD2	PA8MD1	PA8MD0	
PACRL2	—	PA7MD2	PA7MD1	PA7MD0	—	PA6MD2	PA6MD1	PA6MD0	
	—	PA5MD2	PA5MD1	PA5MD0	—	PA4MD2	PA4MD1	PA4MD0	
PACRL1	—	PA3MD2	PA3MD1	PA3MD0	—	PA2MD2	PA2MD1	PA2MD0	
	—	PA1MD2	PA1MD1	PA1MD0	—	PA0MD2	PA0MD1	PA0MD0	
PAPRL	PA15PR	PA14PR	PA13PR	PA12PR	PA11PR	PA10PR	PA9PR	PA8PR	I/O
	PA7PR	PA6PR	PA5PR	PA4PR	PA3PR	PA2PR	PA1PR	PA0PR	
PBDRH	—	—	—	—	—	—	—	—	
	—	—	—	—	—	PB18DR	PB17DR	PB16DR	
PBDRL	—	—	—	—	—	—	—	—	
	—	—	PB5DR	PB4DR	PB3DR	PB2DR	PB1DR* ¹	PB0DR* ¹	
PBIORH	—	—	—	—	—	—	—	—	PFC
	—	—	—	—	—	PB18IOR	PB17IOR	PB16IOR	
PBIORL	—	—	—	—	—	—	—	—	
	—	—	PB5IOR	PB4IOR	PB3IOR	PB2IOR	PB1IOR	PB0IOR	
PBCRH1	—	—	—	—	—	—	—	PB18MD	
	—	—	—	PB17MD	—	—	—	PB16MD	
PBCRL2	—	—	—	—	—	—	—	—	
	—	PB5MD2	PB5MD1	PB5MD0	—	PB4MD2	PB4MD1	PB4MD0	

Register Abbreviation	Bit 31/23/15/7	Bit 30/22/14/6	Bit 29/21/13/5	Bit 28/20/12/4	Bit 27/19/11/3	Bit 26/18/10/2	Bit 25/17/9/1	Bit 24/16/8/0	Module
PBCRL1	—	PB3MD2	PB3MD1	PB3MD0	—	PB2MD2	PB2MD1	PB2MD0	PFC
	—	PB1MD2* ¹	PB1MD1* ¹	PB1MD0* ¹	—	PB0MD2* ¹	PB0MD1* ¹	PB0MD0* ¹	
PBPRH	—	—	—	—	—	—	—	—	I/O
	—	—	—	—	—	PB18PR	PB17PR	PB16PR	
PBPRL	—	—	—	—	—	—	—	—	I/O
	—	—	PB5PR	PB4PR	PB3PR	PB2PR	PB1PR* ¹	PB0PR* ¹	
PDDR1* ²	PD15DR	PD14DR	PD13DR	PD12DR	PD11DR	PD10DR	PD9DR	PD8DR	I/O
	PD7DR	PD6DR	PD5DR	PD4DR	PD3DR	PD2DR	PD1DR	PD0DR	
PDIOR1* ²	PD15IOR	PD14IOR	PD13IOR	PD12IOR	PD11IOR	PD10IOR	PD9IOR	PD8IOR	PFC
	PD7IOR	PD6IOR	PD5IOR	PD4IOR	PD3IOR	PD2IOR	PD1IOR	PD0IOR	
PDCRL4* ²	—	—	PD15MD1	PD15MD0	—	—	PD14MD1	PD14MD0	I/O
	—	—	PD13MD1	PD13MD0	—	—	PD12MD1	PD12MD0	
PDCRL3* ²	—	—	PD11MD1	PD11MD0	—	PD10MD2	PD10MD1	PD10MD0	I/O
	—	PD9MD2	PD9MD1	PD9MD0	—	PD8MD2	PD8MD1	PD8MD0	
PDCRL2* ²	—	PD7MD2	PD7MD1	PD7MD0	—	PD6MD2	PD6MD1	PD6MD0	I/O
	—	PD5MD2	PD5MD1	PD5MD0	—	PD4MD2	PD4MD1	PD4MD0	
PDCRL1* ²	—	PD3MD2	PD3MD1	PD3MD0	—	PD2MD2	PD2MD1	PD2MD0	I/O
	—	PD1MD2	PD1MD1	PD1MD0	—	PD0MD2	PD0MD1	PD0MD0	
PDPRL* ²	PD15PR	PD14PR	PD13PR	PD12PR	PD11PR	PD10PR	PD9PR	PD8PR	I/O
	PD7PR	PD6PR	PD5PR	PD4PR	PD3PR	PD2PR	PD1PR	PD0PR	
PEDRH	—	—	—	—	—	—	—	—	I/O
	—	—	PE21DR	PE20DR	PE19DR	PE18DR	PE17DR	PE16DR	
PEDRL	PE15DR	PE14DR	PE13DR	PE12DR	PE11DR	PE10DR	PE9DR	PE8DR	I/O
	PE7DR	PE6DR	PE5DR	PE4DR	PE3DR	PE2DR	PE1DR	PE0DR	
PEIORH	—	—	—	—	—	—	—	—	PFC
	—	—	PE21IOR	PE20IOR	PE19IOR	PE18IOR	PE17IOR	PE16IOR	
PEIORL	PE15IOR	PE14IOR	PE13IOR	PE12IOR	PE11IOR	PE10IOR	PE9IOR	PE8IOR	PFC
	PE7IOR	PE6IOR	PE5IOR	PE4IOR	PE3IOR	PE2IOR	PE1IOR	PE0IOR	

Register Abbreviation	Bit 31/23/15/7	Bit 30/22/14/6	Bit 29/21/13/5	Bit 28/20/12/4	Bit 27/19/11/3	Bit 26/18/10/2	Bit 25/17/9/1	Bit 24/16/8/0	Module
PECRH2	—	—	—	—	—	—	—	—	PFC
	—	—	PE21MD1	PE21MD0	—	—	PE20MD1	PE20MD0	
PECRH1	—	—	PE19MD1	PE19MD0	—	—	PE18MD1	PE18MD0	
	—	—	PE17MD1	PE17MD0	—	PE16MD2	PE16MD1	PE16MD0	
PECRL4	—	PE15MD2	PE15MD1	PE15MD0	—	PE14MD2	PE14MD1	PE14MD0	
	—	—	PE13MD1	PE13MD0	—	PE12MD2	PE12MD1	PE12MD0	
PECRL3	—	PE11MD2	PE11MD1	PE11MD0	—	PE10MD2	PE10MD1	PE10MD0	
	—	PE9MD2	PE9MD1	PE9MD0	—	PE8MD2	PE8MD1	PE8MD0	
PECRL2	—	PE7MD2	PE7MD1	PE7MD0	—	PE6MD2	PE6MD1	PE6MD0	
	—	PE5MD2	PE5MD1	PE5MD0	—	PE4MD2	PE4MD1	PE4MD0	
PECRL1	—	PE3MD2	PE3MD1	PE3MD0	—	PE2MD2	PE2MD1	PE2MD0	
	—	PE1MD2	PE1MD1	PE1MD0	—	—	PE0MD1	PE0MD0	
PEPRH	—	—	—	—	—	—	—	—	I/O
	—	—	PE21PR	PE20PR	PE19PR	PE18PR	PE17PR	PE16PR	
PEPRL	PE15PR	PE14PR	PE13PR	PE12PR	PE11PR	PE10PR	PE9PR	PE8PR	
	PE7PR	PE6PR	PE5PR	PE4PR	PE3PR	PE2PR	PE1PR	PE0PR	
IFCR	—	—	—	—	—	—	—	—	PFC
	—	—	—	—	—	—	IRQMD1	IRQMD0	
PFDR	PF15DR	PF14DR	PF13DR	PF12DR	PF11DR	PF10DR	PF9DR	PF8DR	I/O
	—	PF6DR	—	PF4DR	—	PF2DR	—	PF0DR	
FRQCR	—	IFC[2:0]			BFC[2:0]			PFC[2]	CPG
	PFC[1:0]		MFC[2:0]			MPFC[2:0]			
STBCR1	STBY	—	—	—	—	—	—	—	Power-down modes
STBCR2	MSTP7	MSTP6	—	MSTP4*3	—	—	—	—	
STBCR3	—	—	MSTP13	MSTP12	MSTP11	—	—	—	
STBCR4	MSTP23	MSTP22	MSTP21	—	—	MSTP18	MSTP17	MSTP16	
STBCR5	—	—	—	—	—	—	MSTP25	MSTP24	
STBCR6	AUDSRST	HIZ	—	—	—	—	STBYMD	—	
WTCNT	—	—	—	—	—	—	—	—	WDT
WTCSR	TME	WT/IT	RSTS	WOVF	IOVF	CKS[2:0]			
OSCCR	—	—	—	—	—	OSCSTOP	—	OSCERS	CPG

Register Abbreviation	Bit 31/23/15/7	Bit 30/22/14/6	Bit 29/21/13/5	Bit 28/20/12/4	Bit 27/19/11/3	Bit 26/18/10/2	Bit 25/17/9/1	Bit 24/16/8/0	Module
RAMCR	—	—	—	RAME	—	—	—	—	Power-down modes
ADTSR_0	TRG11S[3:0]			TRG01S[3:0]					A/D
	TRG1S[3:0]			TRG0S[3:0]					
ADTSR_1	TRG2S[3:0]			—	—	—	—	—	
	—	—	—	—	—	—	—	—	
BSCEHR	DTLOCK	CSSTP1	—	CSSTP2	DTBST	DTSA	CSSTP3	DTPR	BSC
	—	—	—	—	—	—	—	—	
ICR0	NMIL	—	—	—	—	—	—	NMIE	INTC
	—	—	—	—	—	—	—	—	
IRQCR	—	—	—	—	—	—	—	—	
	IRQ31S	IRQ30S	IRQ21S	IRQ20S	IRQ11S	IRQ10S	IRQ01S	IRQ00S	
IRQSR	—	—	—	—	IRQ3L	IRQ2L	IRQ1L	IRQ0L	
	—	—	—	—	IRQ3F	IRQ2F	IRQ1F	IRQ0F	
IPRA	IRQ0	IRQ0	IRQ0	IRQ0	IRQ1	IRQ1	IRQ1	IRQ1	
	IRQ2	IRQ2	IRQ2	IRQ2	IRQ3	IRQ3	IRQ3	IRQ3	
IPRD	MTU2_0	MTU2_0	MTU2_0	MTU2_0	MTU2_0	MTU2_0	MTU2_0	MTU2_0	
	MTU2_1	MTU2_1	MTU2_1	MTU2_1	MTU2_1	MTU2_1	MTU2_1	MTU2_1	
IPRE	MTU2_2	MTU2_2	MTU2_2	MTU2_2	MTU2_2	MTU2_2	MTU2_2	MTU2_2	
	MTU2_3	MTU2_3	MTU2_3	MTU2_3	MTU2_3	MTU2_3	MTU2_3	MTU2_3	
IPRF	MTU2_4	MTU2_4	MTU2_4	MTU2_4	MTU2_4	MTU2_4	MTU2_4	MTU2_4	
	MTU2_5	MTU2_5	MTU2_5	MTU2_5	POE(MTU2)	POE(MTU2)	POE(MTU2)	POE(MTU2)	
IPRH	—	—	—	—	—	—	—	—	
	MTU2S_3	MTU2S_3	MTU2S_3	MTU2S_3	MTU2S_3	MTU2S_3	MTU2S_3	MTU2S_3	
IPRI	MTU2S_4	MTU2S_4	MTU2S_4	MTU2S_4	MTU2S_4	MTU2S_4	MTU2S_4	MTU2S_4	
	MTU2S_5	MTU2S_5	MTU2S_5	MTU2S_5	POE(MTU2S)	POE(MTU2S)	POE(MTU2S)	POE(MTU2S)	
IPRJ	CMT_0	CMT_0	CMT_0	CMT_0	CMT_1	CMT_1	CMT_1	CMT_1	
	—	—	—	—	WDT	WDT	WDT	WDT	
IPRK	A/D_0,1	A/D_0,1	A/D_0,1	A/D_0,1	A/D_2	A/D_2	A/D_2	A/D_2	
	—	—	—	—	—	—	—	—	
IPRL	SCI_0	SCI_0	SCI_0	SCI_0	SCI_1	SCI_1	SCI_1	SCI_1	
	SCI_2	SCI_2	SCI_2	SCI_2	—	—	—	—	

Register Abbreviation	Bit 31/23/15/7	Bit 30/22/14/6	Bit 29/21/13/5	Bit 28/20/12/4	Bit 27/19/11/3	Bit 26/18/10/2	Bit 25/17/9/1	Bit 24/16/8/0	Module
CMNCR	—	—	—	—	—	—	—	—	BSC
	—	—	—	—	—	—	—	—	
	—	—	—	—	—	—	—	—	
	—	—	—	—	—	—	HIZMEM	—	
CS0BCR	—	—	IWW[1:0]		—	IWRWD[1:0]		—	BSC
	IWRWS[1:0]		—	IWRRD[1:0]		—	IWRRS[1:0]		
	—	—	—	—	—	BSZ[1:0]		—	
	—	—	—	—	—	—	—	—	
CS1BCR	—	—	IWW[1:0]		—	IWRWD[1:0]		—	BSC
	IWRWS[1:0]		—	IWRRD[1:0]		—	IWRRS[1:0]		
	—	—	—	—	—	BSZ[1:0]		—	
	—	—	—	—	—	—	—	—	
CS0WCR	—	—	—	—	—	—	—	—	BSC
	—	—	—	—	—	WW[2:0]		—	
	—	—	—	SW[1:0]		WR[3:1]		—	
	WR[0]	WM	—	—	—	—	HW[1:0]		
CS1WCR	—	—	—	—	—	—	—	—	BSC
	—	—	—	—	—	WW[2:0]		—	
	—	—	—	SW[1:0]		WR[3:1]		—	
	WR[0]	WM	—	—	—	—	HW[1:0]		
RAMER	—	—	—	—	—	—	—	—	FLASH (Only in F-ZTAT version)
	—	—	—	—	RAMS	RAM[2:0]			
BARA	BAA31	BAA30	BAA29	BAA28	BAA27	BAA26	BAA25	BAA24	UBC
	BAA23	BAA22	BAA21	BAA20	BAA19	BAA18	BAA17	BAA16	
	BAA15	BAA14	BAA13	BAA12	BAA11	BAA10	BAA9	BAA8	
	BAA7	BAA6	BAA5	BAA4	BAA3	BAA2	BAA1	BAA0	
BAMRA	BAMA31	BAMA30	BAMA29	BAMA28	BAMA27	BAMA26	BAMA25	BAMA24	UBC
	BAMA23	BAMA22	BAMA21	BAMA20	BAMA19	BAMA18	BAMA17	BAMA16	
	BAMA15	BAMA14	BAMA13	BAMA12	BAMA11	BAMA10	BAMA9	BAMA8	
	BAMA7	BAMA6	BAMA5	BAMA4	BAMA3	BAMA2	BAMA1	BAMA0	

Register Abbreviation	Bit 31/23/15/7	Bit 30/22/14/6	Bit 29/21/13/5	Bit 28/20/12/4	Bit 27/19/11/3	Bit 26/18/10/2	Bit 25/17/9/1	Bit 24/16/8/0	Module
BBRA	—	—	—	—	—	CPA2* ³	CPA1* ³	CPA0* ³	UBC
	CDA1* ³	CDA0	IDA1* ³	IDA0	RWA1* ³	RWA0	SZA1* ³	SZA0* ³	
BDRA* ⁴	BDA31	BDA30	BDA29	BDA28	BDA27	BDA26	BDA25	BDA24	
	BDA23	BDA22	BDA21	BDA20	BDA19	BDA18	BDA17	BDA16	
	BDA15	BDA14	BDA13	BDA12	BDA11	BDA10	BDA9	BDA8	
	BDA7	BDA6	BDA5	BDA4	BDA3	BDA2	BDA1	BDA0	
BDMRA* ⁴	BDMA31	BDMA30	BDMA29	BDMA28	BDMA27	BDMA26	BDMA25	BDMA24	
	BDMA23	BDMA22	BDMA21	BDMA20	BDMA19	BDMA18	BDMA17	BDMA16	
	BDMA15	BDMA14	BDMA13	BDMA12	BDMA11	BDMA10	BDMA9	BDMA8	
	BDMA7	BDMA6	BDMA5	BDMA4	BDMA3	BDMA2	BDMA1	BDMA0	
BARB	BAB31	BAB30	BAB29	BAB28	BAB27	BAB26	BAB25	BAB24	
	BAB23	BAB22	BAB21	BAB20	BAB19	BAB18	BAB17	BAB16	
	BAB15	BAB14	BAB13	BAB12	BAB11	BAB10	BAB9	BAB8	
	BAB7	BAB6	BAB5	BAB4	BAB3	BAB2	BAB1	BAB0	
BAMRB	BAMB31	BAMB30	BAMB29	BAMB28	BAMB27	BAMB26	BAMB25	BAMB24	
	BAMB23	BAMB22	BAMB21	BAMB20	BAMB19	BAMB18	BAMB17	BAMB16	
	BAMB15	BAMB14	BAMB13	BAMB12	BAMB11	BAMB10	BAMB9	BAMB8	
	BAMB7	BAMB6	BAMB5	BAMB4	BAMB3	BAMB2	BAMB1	BAMB0	
BBRB	—	—	—	—	—	CPB2* ³	CPB1* ³	CPB0* ³	
	CDB1* ³	CDB0	IDB1* ³	IDB0	RWB1* ³	RWB0	SZB1* ³	SZB0* ³	
BDRB* ⁴	BDB31	BDB30	BDB29	BDB28	BDB27	BDB26	BDB25	BDB24	
	BDB23	BDB22	BDB21	BDB20	BDB19	BDB18	BDB17	BDB16	
	BDB15	BDB14	BDB13	BDB12	BDB11	BDB10	BDB9	BDB8	
	BDB7	BDB6	BDB5	BDB4	BDB3	BDB2	BDB1	BDB0	
BDMRB* ⁴	BDMB31	BDMB30	BDMB29	BDMB28	BDMB27	BDMB26	BDMB25	BDMB24	
	BDMB23	BDMB22	BDMB21	BDMB20	BDMB19	BDMB18	BDMB17	BDMB16	
	BDMB15	BDMB14	BDMB13	BDMB12	BDMB11	BDMB10	BDMB9	BDMB8	
	BDMB7	BDMB6	BDMB5	BDMB4	BDMB3	BDMB2	BDMB1	BDMB0	

Register Abbreviation	Bit 31/23/15/7	Bit 30/22/14/6	Bit 29/21/13/5	Bit 28/20/12/4	Bit 27/19/11/3	Bit 26/18/10/2	Bit 25/17/9/1	Bit 24/16/8/0	Module
BRCR	—	—	—	—	—	—	—	—	UBC
	—	—	UTRGW[1:0]		UBIDB	—	UBIDA	—	
	SCMFCA	SCMFCA	SCMFDA* ³	SCMFDB* ³	PCTE* ³	PCBA	—	—	
	DBEA* ³	PCBB	DBEB* ³	—	SEQ* ³	—	—	ETBE* ³	
BRSR* ⁴	SVF	—	—	—	BSA27	BSA26	BSA25	BSA24	
	BSA23	BSA22	BSA21	BSA20	BSA19	BSA18	BSA17	BSA16	
	BSA15	BSA14	BSA13	BSA12	BSA11	BSA10	BSA9	BSA8	
	BSA7	BSA6	BSA5	BSA4	BSA3	BSA2	BSA1	BSA0	
BRDR* ⁴	DVF	—	—	—	BDA27	BDA26	BDA25	BDA24	
	BDA23	BDA22	BDA21	BDA20	BDA19	BDA18	BDA17	BDA16	
	BDA15	BDA14	BDA13	BDA12	BDA11	BDA10	BDA9	BDA8	
	BDA7	BDA6	BDA5	BDA4	BDA3	BDA2	BDA1	BDA0	
BETR* ⁴	—	—	—	—	BET[11:8]				
	BET[7:0]								

- Notes: 1. Reserved in SH7146.
2. Only SH7149.
3. Reserved in masked ROM version.
4. Only in F-ZTAT version.

23.3 Register States in Each Operating Mode

Register Abbreviation	Power-on reset	Manual reset	Software Standby	Deep Software Standby	Module Standby	Sleep	Module
SCSMR_0	Initialized	Retained	Initialized	Initialized	Initialized	Retained	SCI (Channel 0)
SCBRR_0	Initialized	Retained	Initialized	Initialized	Initialized	Retained	
SCSCR_0	Initialized	Retained	Initialized	Initialized	Initialized	Retained	
SCTDR_0	Initialized	Retained	Initialized	Initialized	Initialized	Retained	
SCSSR_0	Initialized	Retained	Initialized	Initialized	Initialized	Retained	
SCRDR_0	Initialized	Retained	Initialized	Initialized	Initialized	Retained	
SCSDCR_0	Initialized	Retained	Initialized	Initialized	Initialized	Retained	
SCSPTR_0	Initialized	Retained	Initialized	Initialized	Initialized	Retained	SCI (Channel 1)
SCSMR_1	Initialized	Retained	Initialized	Initialized	Initialized	Retained	
SCBRR_1	Initialized	Retained	Initialized	Initialized	Initialized	Retained	
SCSCR_1	Initialized	Retained	Initialized	Initialized	Initialized	Retained	
SCTDR_1	Initialized	Retained	Initialized	Initialized	Initialized	Retained	
SCSSR_1	Initialized	Retained	Initialized	Initialized	Initialized	Retained	
SCRDR_1	Initialized	Retained	Initialized	Initialized	Initialized	Retained	
SCSDCR_1	Initialized	Retained	Initialized	Initialized	Initialized	Retained	SCI (Channel 2)
SCSPTR_1	Initialized	Retained	Initialized	Initialized	Initialized	Retained	
SCSMR_2	Initialized	Retained	Initialized	Initialized	Initialized	Retained	
SCBRR_2	Initialized	Retained	Initialized	Initialized	Initialized	Retained	
SCSCR_2	Initialized	Retained	Initialized	Initialized	Initialized	Retained	
SCTDR_2	Initialized	Retained	Initialized	Initialized	Initialized	Retained	
SCSSR_2	Initialized	Retained	Initialized	Initialized	Initialized	Retained	
SCRDR_2	Initialized	Retained	Initialized	Initialized	Initialized	Retained	MTU2
SCSDCR_2	Initialized	Retained	Initialized	Initialized	Initialized	Retained	
SCSPTR_2	Initialized	Retained	Initialized	Initialized	Initialized	Retained	
TCR_3	Initialized	Retained	Initialized	Initialized	Initialized	Retained	
TCR_4	Initialized	Retained	Initialized	Initialized	Initialized	Retained	
TMDR_3	Initialized	Retained	Initialized	Initialized	Initialized	Retained	
TMDR_4	Initialized	Retained	Initialized	Initialized	Initialized	Retained	
TIORH_3	Initialized	Retained	Initialized	Initialized	Initialized	Retained	

Register Abbreviation	Power-on reset	Manual reset	Software Standby	Deep Software Standby	Module Standby	Sleep	Module
TIORL_3	Initialized	Retained	Initialized	Initialized	Initialized	Retained	MTU2
TIORH_4	Initialized	Retained	Initialized	Initialized	Initialized	Retained	
TIORL_4	Initialized	Retained	Initialized	Initialized	Initialized	Retained	
TIER_3	Initialized	Retained	Initialized	Initialized	Initialized	Retained	
TIER_4	Initialized	Retained	Initialized	Initialized	Initialized	Retained	
TOER	Initialized	Retained	Initialized	Initialized	Initialized	Retained	
TGCR	Initialized	Retained	Initialized	Initialized	Initialized	Retained	
TOCR1	Initialized	Retained	Initialized	Initialized	Initialized	Retained	
TOCR2	Initialized	Retained	Initialized	Initialized	Initialized	Retained	
TCNT_3	Initialized	Retained	Initialized	Initialized	Initialized	Retained	
TCNT_4	Initialized	Retained	Initialized	Initialized	Initialized	Retained	
TCDR	Initialized	Retained	Initialized	Initialized	Initialized	Retained	
TDDR	Initialized	Retained	Initialized	Initialized	Initialized	Retained	
TGRA_3	Initialized	Retained	Initialized	Initialized	Initialized	Retained	
TGRB_3	Initialized	Retained	Initialized	Initialized	Initialized	Retained	
TGRA_4	Initialized	Retained	Initialized	Initialized	Initialized	Retained	
TGRB_4	Initialized	Retained	Initialized	Initialized	Initialized	Retained	
TCNTS	Initialized	Retained	Initialized	Initialized	Initialized	Retained	
TCBR	Initialized	Retained	Initialized	Initialized	Initialized	Retained	
TGRC_3	Initialized	Retained	Initialized	Initialized	Initialized	Retained	
TGRD_3	Initialized	Retained	Initialized	Initialized	Initialized	Retained	
TGRC_4	Initialized	Retained	Initialized	Initialized	Initialized	Retained	
TGRD_4	Initialized	Retained	Initialized	Initialized	Initialized	Retained	
TSR_3	Initialized	Retained	Initialized	Initialized	Initialized	Retained	
TSR_4	Initialized	Retained	Initialized	Initialized	Initialized	Retained	
TITCR	Initialized	Retained	Initialized	Initialized	Initialized	Retained	
TITCNT	Initialized	Retained	Initialized	Initialized	Initialized	Retained	
TBTER	Initialized	Retained	Initialized	Initialized	Initialized	Retained	
TDER	Initialized	Retained	Initialized	Initialized	Initialized	Retained	
TOLBR	Initialized	Retained	Initialized	Initialized	Initialized	Retained	
TBTM_3	Initialized	Retained	Initialized	Initialized	Initialized	Retained	

Register Abbreviation	Power-on reset	Manual reset	Software Standby	Deep Software Standby	Module Standby	Sleep	Module
TBTM_4	Initialized	Retained	Initialized	Initialized	Initialized	Retained	MTU2
TADCR	Initialized	Retained	Initialized	Initialized	Initialized	Retained	
TADCORA_4	Initialized	Retained	Initialized	Initialized	Initialized	Retained	
TADCORB_4	Initialized	Retained	Initialized	Initialized	Initialized	Retained	
TADCOBRA_4	Initialized	Retained	Initialized	Initialized	Initialized	Retained	
TADCOBRB_4	Initialized	Retained	Initialized	Initialized	Initialized	Retained	
TWCR	Initialized	Retained	Initialized	Initialized	Initialized	Retained	
TSTR	Initialized	Retained	Initialized	Initialized	Initialized	Retained	
TSYR	Initialized	Retained	Initialized	Initialized	Initialized	Retained	
TCSYSTR	Initialized	Retained	Initialized	Initialized	Initialized	Retained	
TRWER	Initialized	Retained	Initialized	Initialized	Initialized	Retained	
TCR_0	Initialized	Retained	Initialized	Initialized	Initialized	Retained	
TMDR_0	Initialized	Retained	Initialized	Initialized	Initialized	Retained	
TIORH_0	Initialized	Retained	Initialized	Initialized	Initialized	Retained	
TIORL_0	Initialized	Retained	Initialized	Initialized	Initialized	Retained	
TIER_0	Initialized	Retained	Initialized	Initialized	Initialized	Retained	
TSR_0	Initialized	Retained	Initialized	Initialized	Initialized	Retained	
TCNT_0	Initialized	Retained	Initialized	Initialized	Initialized	Retained	
TGRA_0	Initialized	Retained	Initialized	Initialized	Initialized	Retained	
TGRB_0	Initialized	Retained	Initialized	Initialized	Initialized	Retained	
TGRC_0	Initialized	Retained	Initialized	Initialized	Initialized	Retained	
TGRD_0	Initialized	Retained	Initialized	Initialized	Initialized	Retained	
TGRE_0	Initialized	Retained	Initialized	Initialized	Initialized	Retained	
TGRF_0	Initialized	Retained	Initialized	Initialized	Initialized	Retained	
TIER2_0	Initialized	Retained	Initialized	Initialized	Initialized	Retained	
TSR2_0	Initialized	Retained	Initialized	Initialized	Initialized	Retained	
TBTM_0	Initialized	Retained	Initialized	Initialized	Initialized	Retained	
TCR_1	Initialized	Retained	Initialized	Initialized	Initialized	Retained	
TMDR_1	Initialized	Retained	Initialized	Initialized	Initialized	Retained	
TIOR_1	Initialized	Retained	Initialized	Initialized	Initialized	Retained	
TIER_1	Initialized	Retained	Initialized	Initialized	Initialized	Retained	

Register Abbreviation	Power-on reset	Manual reset	Software Standby	Deep Software Standby	Module Standby	Sleep	Module
TSR_1	Initialized	Retained	Initialized	Initialized	Initialized	Retained	MTU2
TCNT_1	Initialized	Retained	Initialized	Initialized	Initialized	Retained	
TGRA_1	Initialized	Retained	Initialized	Initialized	Initialized	Retained	
TGRB_1	Initialized	Retained	Initialized	Initialized	Initialized	Retained	
TICCR	Initialized	Retained	Initialized	Initialized	Initialized	Retained	
TCR_2	Initialized	Retained	Initialized	Initialized	Initialized	Retained	
TMDR_2	Initialized	Retained	Initialized	Initialized	Initialized	Retained	
TIOR_2	Initialized	Retained	Initialized	Initialized	Initialized	Retained	
TIER_2	Initialized	Retained	Initialized	Initialized	Initialized	Retained	
TSR_2	Initialized	Retained	Initialized	Initialized	Initialized	Retained	
TCNT_2	Initialized	Retained	Initialized	Initialized	Initialized	Retained	
TGRA_2	Initialized	Retained	Initialized	Initialized	Initialized	Retained	
TGRB_2	Initialized	Retained	Initialized	Initialized	Initialized	Retained	
TCNTU_5	Initialized	Retained	Initialized	Initialized	Initialized	Retained	
TGRU_5	Initialized	Retained	Initialized	Initialized	Initialized	Retained	
TCRU_5	Initialized	Retained	Initialized	Initialized	Initialized	Retained	
TIORU_5	Initialized	Retained	Initialized	Initialized	Initialized	Retained	
TCNTV_5	Initialized	Retained	Initialized	Initialized	Initialized	Retained	
TGRV_5	Initialized	Retained	Initialized	Initialized	Initialized	Retained	
TCRV_5	Initialized	Retained	Initialized	Initialized	Initialized	Retained	
TIORV_5	Initialized	Retained	Initialized	Initialized	Initialized	Retained	
TCNTW_5	Initialized	Retained	Initialized	Initialized	Initialized	Retained	
TGRW_5	Initialized	Retained	Initialized	Initialized	Initialized	Retained	
TCRW_5	Initialized	Retained	Initialized	Initialized	Initialized	Retained	
TIORW_5	Initialized	Retained	Initialized	Initialized	Initialized	Retained	
TSR_5	Initialized	Retained	Initialized	Initialized	Initialized	Retained	
TIER_5	Initialized	Retained	Initialized	Initialized	Initialized	Retained	
TSTR5	Initialized	Retained	Initialized	Initialized	Initialized	Retained	
TCNTCMPCLR	Initialized	Retained	Initialized	Initialized	Initialized	Retained	

Register Abbreviation	Power-on reset	Manual reset	Software Standby	Deep Software Standby	Module Standby	Sleep	Module
TCR_3S	Initialized	Retained	Initialized	Initialized	Initialized	Retained	MTU2S
TCR_4S	Initialized	Retained	Initialized	Initialized	Initialized	Retained	
TMDR_3S	Initialized	Retained	Initialized	Initialized	Initialized	Retained	
TMDR_4S	Initialized	Retained	Initialized	Initialized	Initialized	Retained	
TIORH_3S	Initialized	Retained	Initialized	Initialized	Initialized	Retained	
TIORL_3S	Initialized	Retained	Initialized	Initialized	Initialized	Retained	
TIORH_4S	Initialized	Retained	Initialized	Initialized	Initialized	Retained	
TIORL_4S	Initialized	Retained	Initialized	Initialized	Initialized	Retained	
TIER_3S	Initialized	Retained	Initialized	Initialized	Initialized	Retained	
TIER_4S	Initialized	Retained	Initialized	Initialized	Initialized	Retained	
TOERS	Initialized	Retained	Initialized	Initialized	Initialized	Retained	
TGCRS	Initialized	Retained	Initialized	Initialized	Initialized	Retained	
TOCR1S	Initialized	Retained	Initialized	Initialized	Initialized	Retained	
TOCR2S	Initialized	Retained	Initialized	Initialized	Initialized	Retained	
TCNT_3S	Initialized	Retained	Initialized	Initialized	Initialized	Retained	
TCNT_4S	Initialized	Retained	Initialized	Initialized	Initialized	Retained	
TCDRS	Initialized	Retained	Initialized	Initialized	Initialized	Retained	
TDDRS	Initialized	Retained	Initialized	Initialized	Initialized	Retained	
TGRA_3S	Initialized	Retained	Initialized	Initialized	Initialized	Retained	
TGRB_3S	Initialized	Retained	Initialized	Initialized	Initialized	Retained	
TGRA_4S	Initialized	Retained	Initialized	Initialized	Initialized	Retained	
TGRB_4S	Initialized	Retained	Initialized	Initialized	Initialized	Retained	
TCNTSS	Initialized	Retained	Initialized	Initialized	Initialized	Retained	
TCBRS	Initialized	Retained	Initialized	Initialized	Initialized	Retained	
TGRC_3S	Initialized	Retained	Initialized	Initialized	Initialized	Retained	
TGRD_3S	Initialized	Retained	Initialized	Initialized	Initialized	Retained	
TGRC_4S	Initialized	Retained	Initialized	Initialized	Initialized	Retained	
TGRD_4S	Initialized	Retained	Initialized	Initialized	Initialized	Retained	
TSR_3S	Initialized	Retained	Initialized	Initialized	Initialized	Retained	
TSR_4S	Initialized	Retained	Initialized	Initialized	Initialized	Retained	

Register Abbreviation	Power-on reset	Manual reset	Software Standby	Deep Software Standby	Module Standby	Sleep	Module
TITCRS	Initialized	Retained	Initialized	Initialized	Initialized	Retained	MTU2S
TITCNTS	Initialized	Retained	Initialized	Initialized	Initialized	Retained	
TBTERS	Initialized	Retained	Initialized	Initialized	Initialized	Retained	
TDERS	Initialized	Retained	Initialized	Initialized	Initialized	Retained	
TOLBRS	Initialized	Retained	Initialized	Initialized	Initialized	Retained	
TBTM_3S	Initialized	Retained	Initialized	Initialized	Initialized	Retained	
TBTM_4S	Initialized	Retained	Initialized	Initialized	Initialized	Retained	
TADCRS	Initialized	Retained	Initialized	Initialized	Initialized	Retained	
TADCORA_4S	Initialized	Retained	Initialized	Initialized	Initialized	Retained	
TADCORB_4S	Initialized	Retained	Initialized	Initialized	Initialized	Retained	
TADCOBRA_4S	Initialized	Retained	Initialized	Initialized	Initialized	Retained	
TADCOBRB_4S	Initialized	Retained	Initialized	Initialized	Initialized	Retained	
TSYCRS	Initialized	Retained	Initialized	Initialized	Initialized	Retained	
TWCRS	Initialized	Retained	Initialized	Initialized	Initialized	Retained	
TSTRS	Initialized	Retained	Initialized	Initialized	Initialized	Retained	
TSYRS	Initialized	Retained	Initialized	Initialized	Initialized	Retained	
TRWERS	Initialized	Retained	Initialized	Initialized	Initialized	Retained	
TCNTU_5S	Initialized	Retained	Initialized	Initialized	Initialized	Retained	
TGRU_5S	Initialized	Retained	Initialized	Initialized	Initialized	Retained	
TCRU_5S	Initialized	Retained	Initialized	Initialized	Initialized	Retained	
TIORU_5S	Initialized	Retained	Initialized	Initialized	Initialized	Retained	
TCNTV_5S	Initialized	Retained	Initialized	Initialized	Initialized	Retained	
TGRV_5S	Initialized	Retained	Initialized	Initialized	Initialized	Retained	
TCRV_5S	Initialized	Retained	Initialized	Initialized	Initialized	Retained	
TIORV_5S	Initialized	Retained	Initialized	Initialized	Initialized	Retained	
TCNTW_5S	Initialized	Retained	Initialized	Initialized	Initialized	Retained	
TGRW_5S	Initialized	Retained	Initialized	Initialized	Initialized	Retained	
TCRW_5S	Initialized	Retained	Initialized	Initialized	Initialized	Retained	
TIORW_5S	Initialized	Retained	Initialized	Initialized	Initialized	Retained	
TSR_5S	Initialized	Retained	Initialized	Initialized	Initialized	Retained	
TIER_5S	Initialized	Retained	Initialized	Initialized	Initialized	Retained	

Register Abbreviation	Power-on reset	Manual reset	Software Standby	Deep Software Standby	Module Standby	Sleep	Module
TSTR_5S	Initialized	Retained	Initialized	Initialized	Initialized	Retained	MTU2S
TCNTCMPCLRS	Initialized	Retained	Initialized	Initialized	Initialized	Retained	
ADDR0	Initialized	Retained	Initialized	Initialized	Initialized	Retained	A/D (Channel 0)
ADDR2	Initialized	Retained	Initialized	Initialized	Initialized	Retained	
ADCSR_0	Initialized	Retained	Initialized	Initialized	Initialized	Retained	
ADCR_0	Initialized	Retained	Initialized	Initialized	Initialized	Retained	
ADDR4	Initialized	Retained	Initialized	Initialized	Initialized	Retained	A/D (Channel 1)
ADDR6	Initialized	Retained	Initialized	Initialized	Initialized	Retained	
ADCSR_1	Initialized	Retained	Initialized	Initialized	Initialized	Retained	
ADCR_1	Initialized	Retained	Initialized	Initialized	Initialized	Retained	
ADDR8	Initialized	Retained	Initialized	Initialized	Initialized	Retained	A/D (Channel 2)
ADDR9	Initialized	Retained	Initialized	Initialized	Initialized	Retained	
ADDR10	Initialized	Retained	Initialized	Initialized	Initialized	Retained	
ADDR11	Initialized	Retained	Initialized	Initialized	Initialized	Retained	
ADDR12	Initialized	Retained	Initialized	Initialized	Initialized	Retained	
ADDR13	Initialized	Retained	Initialized	Initialized	Initialized	Retained	
ADDR14	Initialized	Retained	Initialized	Initialized	Initialized	Retained	
ADDR15	Initialized	Retained	Initialized	Initialized	Initialized	Retained	
ADCSR_2	Initialized	Retained	Initialized	Initialized	Initialized	Retained	
ADCR_2	Initialized	Retained	Initialized	Initialized	Initialized	Retained	
FCCS	Initialized	Retained	Initialized	Initialized	Initialized	Retained	FLASH
FPCS	Initialized	Retained	Initialized	Initialized	Initialized	Retained	(Only in F-ZTAT version)
FECS	Initialized	Retained	Initialized	Initialized	Initialized	Retained	
FKEY	Initialized	Retained	Initialized	Initialized	Initialized	Retained	
FMATS	Initialized	Retained	Initialized	Initialized	Initialized	Retained	
FTDAR	Initialized	Retained	Initialized	Initialized	Initialized	Retained	
DTCERA	Initialized	Retained	Retained	Initialized	Retained	Retained	DTC
DTCERB	Initialized	Retained	Retained	Initialized	Retained	Retained	(Only in F-ZTAT version)
DTCERC	Initialized	Retained	Retained	Initialized	Retained	Retained	
DTCERD	Initialized	Retained	Retained	Initialized	Retained	Retained	

Register Abbreviation	Power-on reset	Manual reset	Software Standby	Deep Software Standby	Module Standby	Sleep	Module
DTCERE	Initialized	Retained	Retained	Initialized	Retained	Retained	DTC
DTCCR	Initialized	Retained	Retained	Initialized	Retained	Retained	(Only in F-ZTAT version)
DTCVBR	Initialized	Retained	Retained	Initialized	Retained	Retained	
CMSTR	Initialized	Retained	Initialized	Initialized	Initialized	Retained	CMT
CMCSR_0	Initialized	Retained	Initialized	Initialized	Initialized	Retained	
CMCNT_0	Initialized	Retained	Initialized	Initialized	Initialized	Retained	
CMCOR_0	Initialized	Retained	Initialized	Initialized	Initialized	Retained	
CMCSR_1	Initialized	Retained	Initialized	Initialized	Initialized	Retained	
CMCNT_1	Initialized	Retained	Initialized	Initialized	Initialized	Retained	
CMCOR_1	Initialized	Retained	Initialized	Initialized	Initialized	Retained	
ICSR1	Initialized	Retained	Retained	Initialized	—	Retained	POE
OCSR1	Initialized	Retained	Retained	Initialized	—	Retained	
ICSR2	Initialized	Retained	Retained	Initialized	—	Retained	
OCSR2	Initialized	Retained	Retained	Initialized	—	Retained	
ICSR3	Initialized	Retained	Retained	Initialized	—	Retained	
SPOER	Initialized	Retained	Retained	Initialized	—	Retained	
POECR1	Initialized	Retained	Retained	Initialized	—	Retained	
POECR2	Initialized	Retained	Retained	Initialized	—	Retained	
PADRL	Initialized	Retained	Retained	Initialized	—	Retained	I/O
PAIORL	Initialized	Retained	Retained	Initialized	—	Retained	PFC
PACRL4	Initialized	Retained	Retained	Initialized	—	Retained	
PACRL3	Initialized	Retained	Retained	Initialized	—	Retained	
PACRL2	Initialized	Retained	Retained	Initialized	—	Retained	
PACRL1	Initialized	Retained	Retained	Initialized	—	Retained	
PAPRL	Initialized	Retained	Retained	Initialized	—	Retained	I/O
PBDRH	Initialized	Retained	Retained	Initialized	—	Retained	
PBDRL	Initialized	Retained	Retained	Initialized	—	Retained	
PBIORH	Initialized	Retained	Retained	Initialized	—	Retained	PFC
PBIORL	Initialized	Retained	Retained	Initialized	—	Retained	
PBCRH1	Initialized	Retained	Retained	Initialized	—	Retained	
PBCRL2	Initialized	Retained	Retained	Initialized	—	Retained	

Register Abbreviation	Power-on reset	Manual reset	Software Standby	Deep Software Standby	Module Standby	Sleep	Module
PBCRL1	Initialized	Retained	Retained	Initialized	—	Retained	PFC
PBPRH	Initialized	Retained	Retained	Initialized	—	Retained	I/O
PBPRL	Initialized	Retained	Retained	Initialized	—	Retained	
PDDR1* ¹	Initialized	Retained	Retained	Initialized	—	Retained	
PDIORL* ¹	Initialized	Retained	Retained	Initialized	—	Retained	PFC
PDCRL4* ¹	Initialized	Retained	Retained	Initialized	—	Retained	
PDCRL3* ¹	Initialized	Retained	Retained	Initialized	—	Retained	
PDCRL2* ¹	Initialized	Retained	Retained	Initialized	—	Retained	
PDCRL1* ¹	Initialized	Retained	Retained	Initialized	—	Retained	
PDPRL* ¹	Initialized	Retained	Retained	Initialized	—	Retained	I/O
PEDRH	Initialized	Retained	Retained	Initialized	—	Retained	
PEDRL	Initialized	Retained	Retained	Initialized	—	Retained	
PEIORH	Initialized	Retained	Retained	Initialized	—	Retained	PFC
PEIORL	Initialized	Retained	Retained	Initialized	—	Retained	
PECRH2	Initialized	Retained	Retained	Initialized	—	Retained	
PECRH1	Initialized	Retained	Retained	Initialized	—	Retained	
PECRL4	Initialized	Retained	Retained	Initialized	—	Retained	
PECRL3	Initialized	Retained	Retained	Initialized	—	Retained	
PECRL2	Initialized	Retained	Retained	Initialized	—	Retained	
PECRL1	Initialized	Retained	Retained	Initialized	—	Retained	
PEPRH	Initialized	Retained	Retained	Initialized	—	Retained	I/O
PEPRL	Initialized	Retained	Retained	Initialized	—	Retained	
IFCR	Initialized	Retained	Retained	Initialized	—	Retained	PFC
PFDR1	Initialized	Retained	Retained	Initialized	—	Retained	I/O
FRQCR	Initialized* ²	Retained	Retained	Initialized	—	Retained	CPG
STBCR1	Initialized	Retained	Retained	Initialized	—	Retained	Power-down modes
STBCR2	Initialized	Retained	Retained	Initialized	—	Retained	
STBCR3	Initialized	Retained	Retained	Initialized	—	Retained	
STBCR4	Initialized	Retained	Retained	Initialized	—	Retained	
STBCR5	Initialized	Retained	Retained	Initialized	—	Retained	
STBCR6	Initialized	Retained	Retained	Initialized	—	Retained	

Register Abbreviation	Power-on reset	Manual reset	Software Standby	Deep Software Standby	Module Standby	Sleep	Module
WTCNT	Initialized* ²	Retained	Retained	Initialized	—	Retained	WDT
WTCSR	Initialized* ²	Retained	Retained	Initialized	—	Retained	
OSCCR	Initialized* ³	Retained	Retained* ⁴	Initialized	—	Retained	CPG
RAMCR	Initialized	Retained	Retained	Initialized	—	Retained	Power-down modes
ADTSR_0	Initialized	Retained	Retained	Initialized	Retained	Retained	A/D
ADTSR_1	Initialized	Retained	Retained	Initialized	Retained	Retained	
BSCEHR	Initialized	Retained	Retained	Initialized	—	Retained	BSC
ICR0	Initialized	Initialized	Retained	Initialized	—	Retained	INTC
IRQCR	Initialized	Initialized	Retained	Initialized	—	Retained	
IRQSR	Initialized	Initialized	Retained	Initialized	—	Retained	
IPRA	Initialized	Initialized	Retained	Initialized	—	Retained	
IPRD	Initialized	Initialized	Retained	Initialized	—	Retained	
IPRE	Initialized	Initialized	Retained	Initialized	—	Retained	
IPRF	Initialized	Initialized	Retained	Initialized	—	Retained	
IPRH	Initialized	Initialized	Retained	Initialized	—	Retained	
IPRI	Initialized	Initialized	Retained	Initialized	—	Retained	
IPRJ	Initialized	Initialized	Retained	Initialized	—	Retained	
IPRK	Initialized	Initialized	Retained	Initialized	—	Retained	
IPRL	Initialized	Initialized	Retained	Initialized	—	Retained	
CMNCR	Initialized	Retained	Retained	Initialized	—	Retained	BSC
CS0BCR	Initialized	Retained	Retained	Initialized	—	Retained	
CS1BCR	Initialized	Retained	Retained	Initialized	—	Retained	
CS0WCR	Initialized	Retained	Retained	Initialized	—	Retained	
CS1WCR	Initialized	Retained	Retained	Initialized	—	Retained	
RAMER	Initialized	Initialized	Retained	Initialized	Retained	Retained	FLASH (Only in F-ZTAT version)
BARA	Initialized	Retained	Retained	Initialized	Initialized	Retained	UBC
BAMRA	Initialized	Retained	Retained	Initialized	Initialized	Retained	
BBRA	Initialized	Retained	Retained	Initialized	Initialized	Retained	
BDRA* ⁵	Initialized	Retained	Retained	Initialized	Initialized	Retained	

Register Abbreviation	Power-on reset	Manual reset	Software Standby	Deep Software Standby	Module Standby	Sleep	Module
BDMRA* ⁵	Initialized	Retained	Retained	Initialized	Initialized	Retained	UBC
BARB	Initialized	Retained	Retained	Initialized	Initialized	Retained	
BAMRB	Initialized	Retained	Retained	Initialized	Initialized	Retained	
BBRB	Initialized	Retained	Retained	Initialized	Initialized	Retained	
BDRB* ⁵	Initialized	Retained	Retained	Initialized	Initialized	Retained	
BDMRB* ⁵	Initialized	Retained	Retained	Initialized	Initialized	Retained	
BRCR	Initialized	Retained	Retained	Initialized	Initialized	Retained	
BRSR* ⁵	Initialized	Initialized	Retained	Initialized	Initialized	Retained	
BRDR* ⁵	Initialized	Initialized	Retained	Initialized	Initialized	Retained	
BETR* ⁵	Initialized	Retained	Retained	Initialized	Initialized	Retained	

Notes: 1. Only SH7149.

2. Not initialized by a WDT power-on reset.

3. The OSCSTOP bit is not initialized by a WDT power-on reset.

4. The OSCSTOP bit is initialized.

5. Only in F-ZTAT version.

Section 24 Electrical Characteristics

24.1 Absolute Maximum Ratings

Table 24.1 lists the absolute maximum ratings.

Table 24.1 Absolute Maximum Ratings

Item	Symbol	Value	Unit	
Power supply voltage	V_{CC}	-0.3 to +7.0	V	
Input voltage (except analog input pins)	V_{in}	-0.3 to $V_{CC} + 0.3$	V	
Analog power supply voltage	AV_{CC}	-0.3 to +7.0	V	
Analog input voltage	V_{an}	-0.3 to $AV_{CC} + 0.3$	V	
Operating temperature	Consumer applications	T_{opr}	-20 to +85	°C
		Industrial applications	-40 to +85	°C
Storage temperature	T_{stg}	-55 to +125	°C	

[Operating Precautions]

Operating the LSI in excess of the absolute maximum ratings may result in permanent damage.

24.2 DC Characteristics

Table 24.2 lists DC characteristics.

Table 24.2 DC Characteristics

Conditions: $V_{CC} = 4.0\text{ V to }5.5\text{ V}$, $AV_{CC} = 4.0\text{ V to }5.5\text{ V}$, $V_{SS} = PLLV_{SS} = AV_{SS} = 0\text{ V}$
 $T_a = -20^\circ\text{C to }+85^\circ\text{C}$ (consumer applications),
 $T_a = -40^\circ\text{C to }+85^\circ\text{C}$ (industrial applications)

Item	Symbol	Min.	Typ.	Max.	Unit	Test Conditions
Input high-level voltage (except Schmitt trigger input voltage)	\overline{RES} , \overline{MRES} , NMI, FWE, MD1, MD0, $\overline{ASEMD0}$, EXTAL	$V_{CC}-0.7$	—	$V_{CC}+0.3$	V	
	Analog ports	2.2	—	$AV_{CC}+0.3$	V	
	Other input pins	2.2	—	$V_{CC}+0.3$	V	
Input low-level voltage (except Schmitt trigger input voltage)	\overline{RES} , \overline{MRES} , NMI, FWE, MD1, MD0, $\overline{ASEMD0}$, EXTAL	-0.3	—	0.5	V	
	Other input pins	-0.3	—	0.8	V	
Schmitt trigger input voltage	IRQ3 to IRQ0, POE8 to POE0,	$V_{CC}-0.5$	—	—	V	
	TCLKA to TCLKD,	V_{T-}	—	1.0	V	
	TIOC0A to TIOC0D, TIOC1A, TIOC1B, TIOC2A, TIOC2B, TIOC3A to TIOC3D, TIOC4A to TIOC4D, TIC5U, TIC5V, TIC5W, TIOC3BS, TIOC3DS, TIOC4AS to TIOC4DS, TIC5US, TIC5VS, TIC5WS, SCK0 to SCK2, RXD0 to RXD2, \overline{TRST}	$V_{T+}-V_{T-}$	0.4	—	—	V
Input leak current	All input pins (except $\overline{ASEMD0}$, POE3, POE7, and POE8*)	$ I_{in} $	—	1.0	μA	
Input pull-up MOS current	$\overline{ASEMD0}$, $\overline{POE3}$, POE7, and POE8*	$-I_{pu}$	—	800	μA	$V_{in} = 0\text{ V}$

Item		Symbol	Min.	Typ.	Max.	Unit	Test Conditions	
Three-state leak current (OFF state)	Ports A, B, D, E	$ I_{ts} $	—	—	1.0	μA		
Output high-level voltage	All output pins	V_{OH}	$V_{CC} - 0.5$	—	—	V	$I_{OH} = -200 \mu\text{A}$	
			$V_{CC} - 1.0$	—	—	V	$I_{OH} = -1 \text{ mA}$	
	TIOC3B, TIOC3D, TIOC4A to TIOC4D, TIOC3BS, TIOC3DS, TIOC4AS to TIOC4DS		$V_{CC} - 1.0$	—	—	V	$I_{OH} = -5 \text{ mA}$	
	PE9, PE11 to PE21		$V_{CC} - 2.0$	—	—	V	$I_{OH} = -5 \text{ mA}$	
Output low-level voltage	All output pins	V_{OL}	—	—	0.4	V	$I_{OL} = 1.6 \text{ mA}$	
	TIOC3B, TIOC3D, TIOC4A to TIOC4D, TIOC3BS, TIOC3DS, TIOC4AS to TIOC4DS		—	—	1.4	V	$I_{OL} = 15 \text{ mA}$	
	PE9, PE11 to PE21		—	—	2.5	V	$I_{OL} = 15 \text{ mA}$	
Input capacitance	All input pins	C_{in}	—	—	20	pF	$V_{in} = 0 \text{ V}$ $f = 1 \text{ MHz}$ $T_a = 25^\circ\text{C}$	
Supply current	Normal operation	I_{CC}	—	80	125	mA	$I\phi = 80 \text{ MHz}$ $B\phi = 40 \text{ MHz}$ $P\phi = 40 \text{ MHz}$ $MP\phi = 40 \text{ MHz}$ $MI\phi = 80 \text{ MHz}$	
	Sleep		—	65	110	mA	$B\phi = 40 \text{ MHz}$ $P\phi = 40 \text{ MHz}$ $MP\phi = 40 \text{ MHz}$ $MI\phi = 80 \text{ MHz}$	
	Software standby			—	10	40	mA	$T_a \leq 50^\circ\text{C}$
				—	—	80	mA	$50^\circ\text{C} < T_a$
	Deep software standby			—	5	30	μA	$T_a \leq 50^\circ\text{C}$
				—	—	80	μA	$50^\circ\text{C} < T_a$

Item		Symbol	Min.	Typ.	Max.	Unit	Test Conditions
Supply current Only in F-ZTAT version supporting full functions of E10A.	Normal operation	I_{cc}	—	150	165	mA	$I\phi = 80$ MHz $B\phi = 40$ MHz $P\phi = 40$ MHz $MP\phi = 40$ MHz $MI\phi = 80$ MHz
	Sleep		—	140	150	mA	$B\phi = 40$ MHz $P\phi = 40$ MHz $MP\phi = 40$ MHz $MI\phi = 80$ MHz
	Software standby		—	20	60	mA	$T_a \leq 50^\circ\text{C}$
			—	—	120	mA	$50^\circ\text{C} < T_a$
	Deep software standby		—	20	50	μA	$T_a \leq 50^\circ\text{C}$
		—	—	120	μA	$50^\circ\text{C} < T_a$	
Analog power supply current	During A/D conversion	AI_{cc}	—	3	6	mA	The value per A/D converter module.
	Waiting for A/D conversion		—	—	3.5	mA	
	Standby		—	—	10	μA	
RAM standby voltage		V_{RAM}	2.0	—	—	V	V_{cc}

[Operating Precautions]

1. When the A/D converter is not used, do not leave the AV_{cc} and AV_{ss} pins open.
2. The current consumption is measured when V_{IH} (Min.) = $V_{cc} - 0.5$ V, V_{IL} (Max.) = 0.5 V, with all output pins unloaded.

Note: * When the POE8 function is selected for the PB18/ $\overline{\text{POE8}}$ pin by the PFC.

Table 24.3 Permitted Output Current Values

Conditions: $V_{CC} = 4.0\text{ V to }5.5\text{ V}$, $AV_{CC} = 4.0\text{ V to }5.5\text{ V}$, $V_{SS} = PLLV_{SS} = AV_{SS} = 0\text{ V}$,
 $T_a = -20^\circ\text{C to }+85^\circ\text{C}$ (consumer applications),
 $T_a = -40^\circ\text{C to }+85^\circ\text{C}$ (industrial applications)

Item	Symbol	Min.	Typ.	Max.	Unit
Output low-level permissible current (per pin)	I_{OL}	—	—	2.0*	mA
Output low-level permissible current (total)	ΣI_{OL}	—	—	110	mA
Output high-level permissible current (per pin)	$-I_{OH}$	—	—	2.0*	mA
Output high-level permissible current (total)	$\Sigma -I_{OH}$	—	—	35	mA

[Operating Precautions]

To assure LSI reliability, do not exceed the output values listed in table 24.3.

Note: * $I_{OL} = 15\text{ mA (Max.)}$ / $-I_{OH} = 5\text{ mA (Max.)}$ about pins PE9 and PE11 to PE21. However, at most six pins are permitted to have simultaneously $I_{OL}/-I_{OH} > 2.0\text{ mA}$ among these pins.

24.3 AC Characteristics

Signals input to this LSI are basically handled as signals in synchronization with a clock. The setup and hold times for input pins must be followed.

Table 24.4 Maximum Operating Frequency

Conditions: $V_{CC} = 4.0\text{ V to }5.5\text{ V}$, $AV_{CC} = 4.0\text{ V to }5.5\text{ V}$, $V_{SS} = PLLV_{SS} = AV_{SS} = 0\text{ V}$,
 $T_a = -20^\circ\text{C to }+85^\circ\text{C}$ (consumer applications),
 $T_a = -40^\circ\text{C to }+85^\circ\text{C}$ (industrial applications)

Item		Symbol	Min.	Typ.	Max.	Unit	Remarks
Operating frequency	CPU ($I\phi$)	f	10	—	80	MHz	
	External bus ($B\phi$)		10	—	40		
	Peripheral module ($P\phi$)		10	—	40		
	MTU2 ($MP\phi$)		10	—	40		
	MTU2S ($MI\phi$)		10	—	80		

24.3.1 Clock Timing

Table 24.5 Clock Timing

Conditions: $V_{CC} = 4.0\text{ V to }5.5\text{ V}$, $AV_{CC} = 4.0\text{ V to }5.5\text{ V}$, $V_{SS} = PLLV_{SS} = AV_{SS} = 0\text{ V}$,
 $T_a = -20^\circ\text{C to }+85^\circ\text{C}$ (consumer applications),
 $T_a = -40^\circ\text{C to }+85^\circ\text{C}$ (industrial applications)

Item	Symbol	Min.	Max.	Unit	Reference Figure
EXTAL clock input frequency	f_{EX}	5	12.5	MHz	Figure 24.1
EXTAL clock input cycle time	t_{EXcyc}	80	200	ns	
EXTAL clock input low pulse width	t_{EXL}	20	—	ns	
EXTAL clock input high pulse width	t_{EXH}	20	—	ns	
EXTAL clock input rise time	t_{EXr}	—	5	ns	
EXTAL clock input fall time	t_{EXf}	—	5	ns	
CK clock output frequency	f_{OP}	10	40	MHz	Figure 24.2
CK clock output cycle time	t_{cyc}	25	100	ns	
CK clock output low pulse width	t_{CKL}	$1/2t_{cyc} - 7.5$	—	ns	
CK clock output high pulse width	t_{CKH}	$1/2t_{cyc} - 7.5$	—	ns	
CK clock output rise time	t_{CKr}	—	5	ns	
CK clock output fall time	t_{CKf}	—	5	ns	
Power-on oscillation settling time	t_{OSC1}	10	—	ms	Figure 24.3
Standby return oscillation settling time 1	t_{OSC2}	10	—	ms	Figure 24.4
Standby return oscillation settling time 2	t_{OSC3}	10	—	ms	Figure 24.5

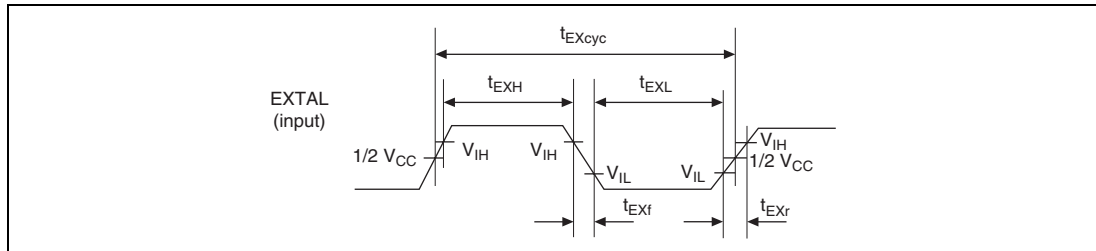

Figure 24.1 EXTAL Clock Input Timing

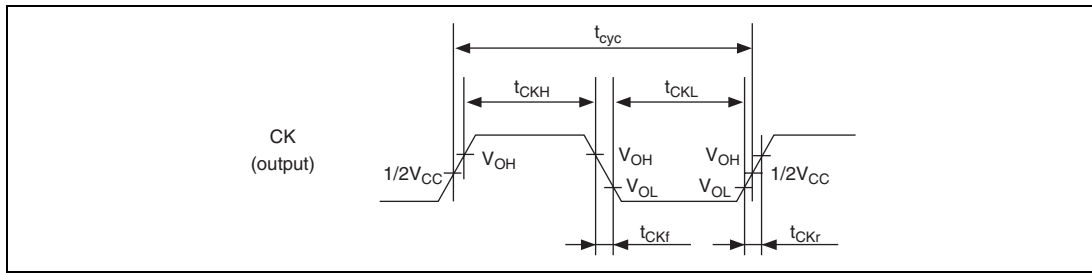

Figure 24.2 CK Clock Output Timing

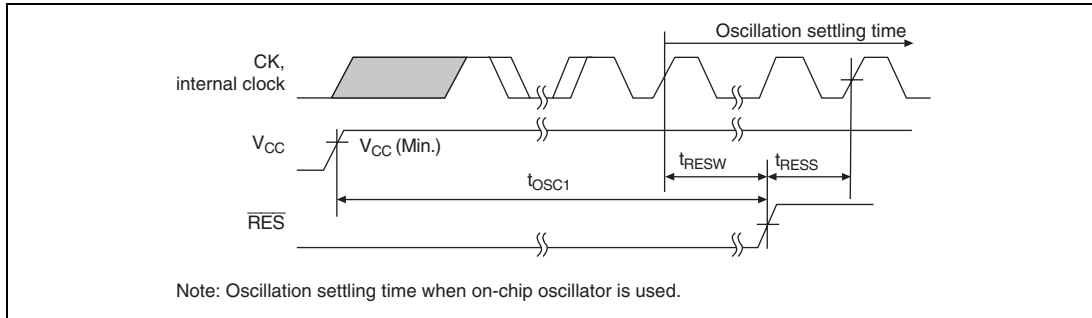

Figure 24.3 Power-On Oscillation Settling Timing

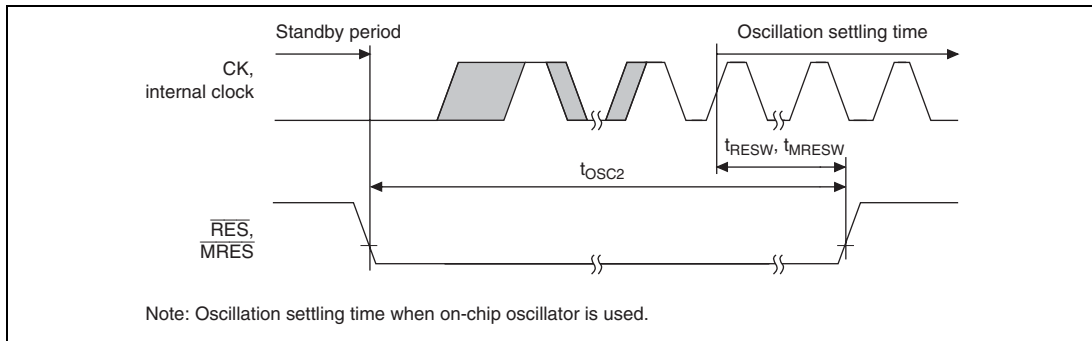

Figure 24.4 Oscillation Settling Timing on Return from Standby (Return by Reset)

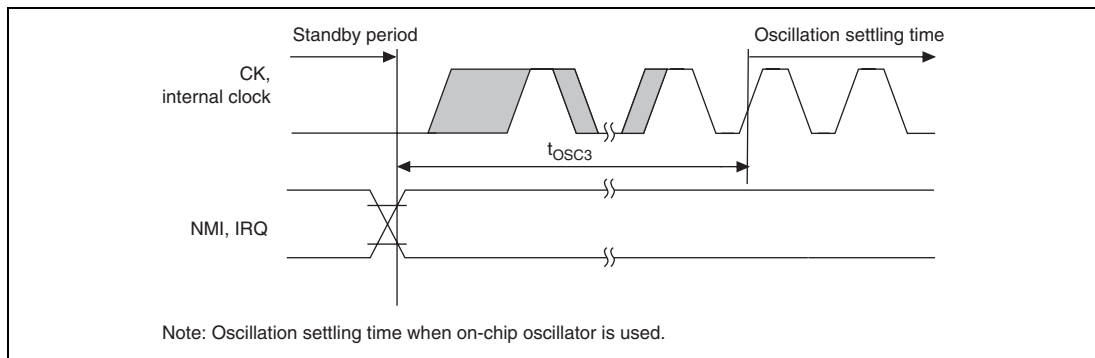

Figure 24.5 Oscillation Settling Timing on Return from Standby (Return by NMI or IRQ)

24.3.2 Control Signal Timing

Table 24.6 Control Signal Timing

Conditions: $V_{CC} = 4.0\text{ V to }5.5\text{ V}$, $AV_{CC} = 4.0\text{ V to }5.5\text{ V}$, $V_{SS} = PLLV_{SS} = AV_{SS} = 0\text{ V}$,
 $T_a = -20^\circ\text{C to }+85^\circ\text{C}$ (consumer applications),
 $T_a = -40^\circ\text{C to }+85^\circ\text{C}$ (industrial applications)

Item	Symbol	Min.	Max.	Unit	Reference Figure
$\overline{\text{RES}}$ pulse width	t_{RESW}	20* ²	—	t_{Bcyc} * ⁴	Figures 24.3, 24.4,
$\overline{\text{RES}}$ setup time* ¹	t_{RESS}	65	—	ns	24.6, 24.7
$\overline{\text{RES}}$ hold time	t_{RESH}	15	—	ns	
$\overline{\text{MRES}}$ pulse width	t_{MRESW}	20* ³	—	t_{Bcyc} * ⁴	
$\overline{\text{MRES}}$ setup time* ¹	t_{MRESS}	25	—	ns	
$\overline{\text{MRES}}$ hold time	t_{MRESH}	15	—	ns	
MD1, MD0, FWE setup time	t_{MDS}	20	—	t_{Bcyc} * ⁴	Figure 24.6
$\overline{\text{BREQ}}$ setup time	t_{BREQS}	$1/2t_{\text{Bcyc}} + 15$	—	ns	Figure 24.9
$\overline{\text{BREQ}}$ hold time	t_{BREQH}	$1/2t_{\text{Bcyc}} + 10$	—	ns	
NMI setup time* ¹	t_{NMIS}	60	—	ns	Figure 24.7
NMI hold time	t_{NMIH}	10	—	ns	
IRQ3 to IRQ0 setup time* ¹	t_{IRQS}	35	—	ns	
IRQ3 to IRQ0 hold time	t_{IROH}	35	—	ns	
$\overline{\text{IRQOUT}}$ output delay time	t_{IRQOD}	—	100	ns	Figure 24.8
BACK delay time	t_{BACKD}	—	$1/2t_{\text{Bcyc}} + 20$	ns	Figures 24.9, 24.10
Bus tri-state delay time	t_{BOFF}	0	100	ns	
Bus buffer on time	t_{BON}	0	100	ns	

- Notes: 1. The $\overline{\text{RES}}$, $\overline{\text{MRES}}$, NMI, $\overline{\text{BREQ}}$, and IRQ3 to IRQ0 signals are asynchronous signals. When the setup time is satisfied, change of signal level is detected at the rising edge of the clock. If not, the detection is delayed until the next rising edge of the clock.
2. In standby mode, $t_{\text{RESW}} = t_{\text{OSC2}}$ (10 ms).
3. In standby mode, $t_{\text{MRESW}} = t_{\text{OSC2}}$ (10 ms).
4. t_{Bcyc} indicates external bus clock cycle time ($B\phi = CK$).

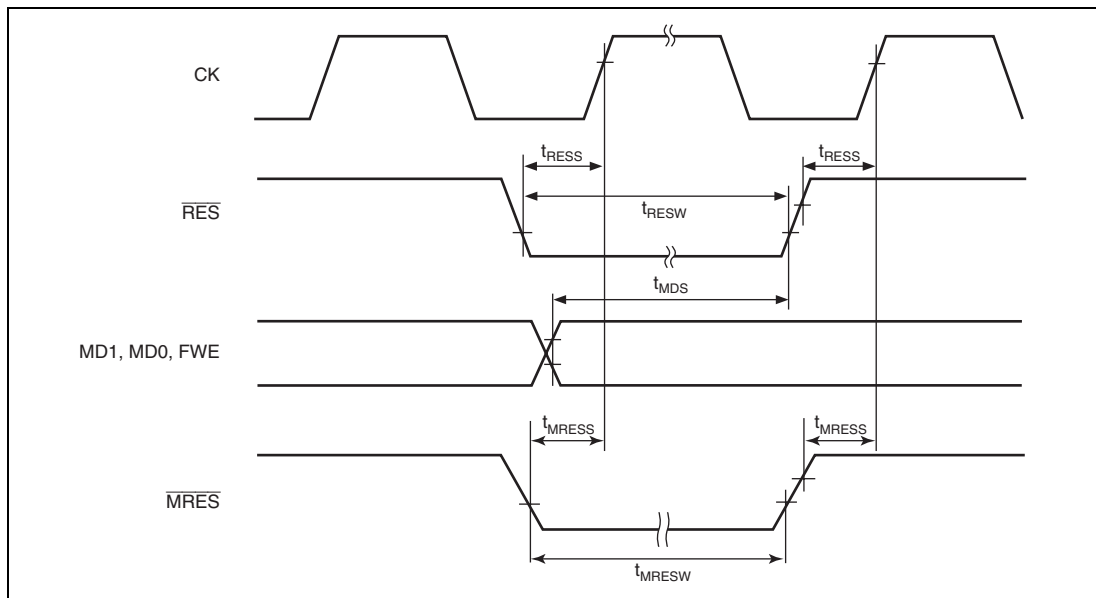

Figure 24.6 Reset Input Timing

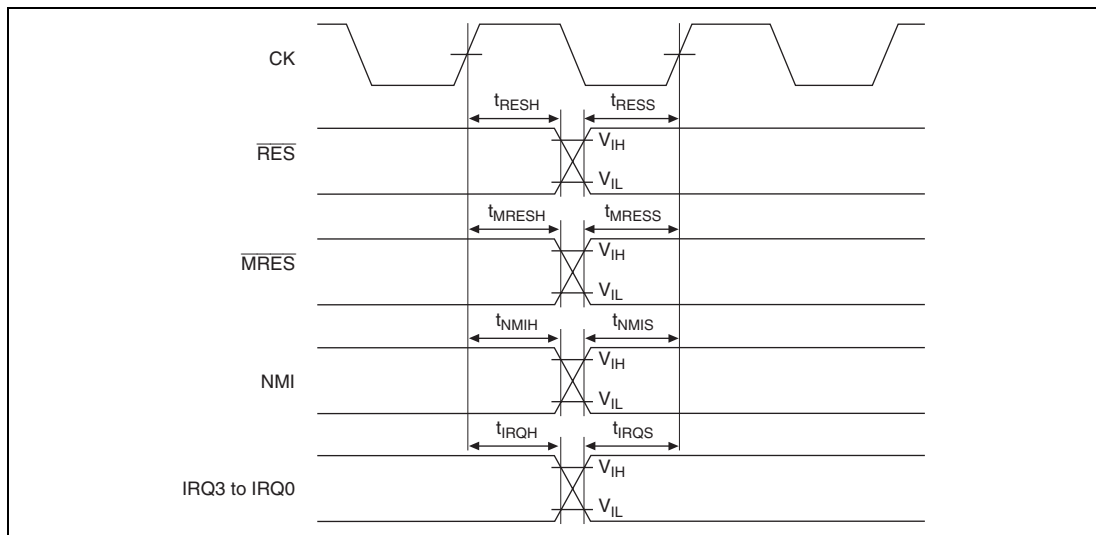

Figure 24.7 Interrupt Signal Input Timing

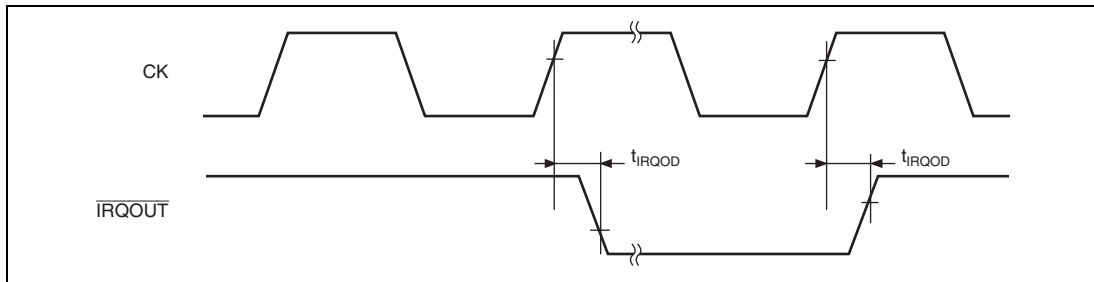

Figure 24.8 Interrupt Signal Output Timing

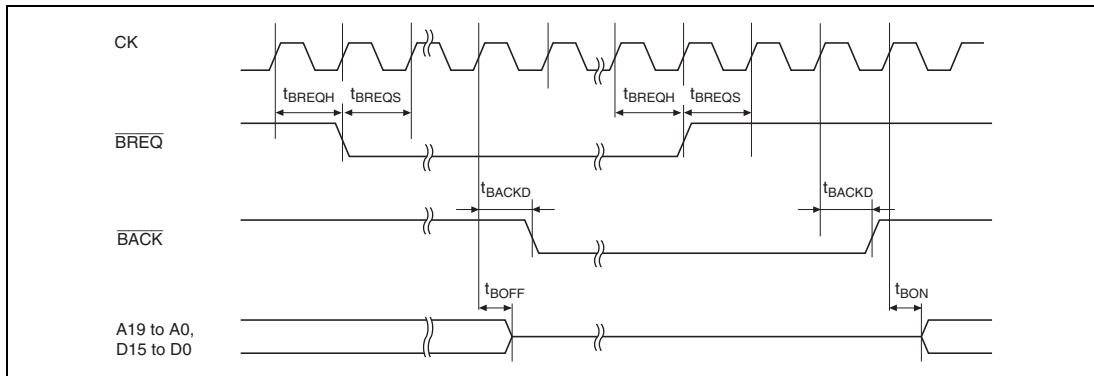

Figure 24.9 Bus Release Timing

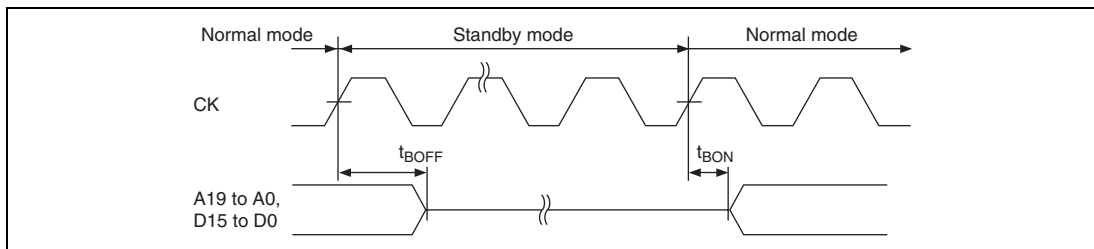

Figure 24.10 Pin Driving Timing in Standby Mode

24.3.3 AC Bus Timing

Table 24.7 Bus Timing

Conditions: $V_{CC} = 4.0\text{ V to }5.5\text{ V}$, $AV_{CC} = 4.0\text{ V to }5.5\text{ V}$, $V_{SS} = PLLV_{SS} = AV_{SS} = 0\text{ V}$,
 $T_a = -20^\circ\text{C to }+85^\circ\text{C}$ (consumer applications),
 $T_a = -40^\circ\text{C to }+85^\circ\text{C}$ (industrial applications)

Item	Symbol	Min.	Max.	Unit	Reference Figure
Address delay time 1	t_{AD1}	1	18 (20)* ³	ns	Figures 24.11 to 24.15
Address setup time	t_{AS}	0	—	ns	Figures 24.11 to 24.14
Address hold time	t_{AH}	0	—	ns	Figures 24.11 to 24.14
\overline{CS} delay time	t_{CSD}	1	18 (20)* ³	ns	Figures 24.11 to 24.15
\overline{CS} setup time	t_{CSS}	0	—	ns	Figures 24.11 to 24.14
\overline{CS} hold time	t_{CSH}	0	—	ns	Figures 24.11 to 24.14
Read strobe delay time	t_{RSD}	$1/2t_{Bcyc} + 1$	$1/2t_{Bcyc} + 18$ (20)* ³	ns	Figures 24.11 to 24.15
Read data setup time 1	t_{RDS1}	$1/2t_{Bcyc} + 18$ (20)* ³	—	ns	Figures 24.11 to 24.15
Read data hold time 1	t_{RDH1}	0	—	ns	Figures 24.11 to 24.15
Read data access time	t_{ACC} * ²	$t_{Bcyc} \times (n + 1.5)$ — 33* ¹ (35)* ³	—	ns	Figures 24.11 to 24.15
Access time from read strobe	t_{OE} * ²	$t_{Bcyc} \times (n + 1)$ — 33* ¹ (35)* ³	—	ns	Figures 24.11 to 24.15
Write strobe delay time 1	t_{WSD1}	$1/2t_{Bcyc} + 1$	$1/2t_{Bcyc} + 18$ (20)* ³	ns	Figures 24.11 to 24.15
Write data delay time 1	t_{WDD1}	—	18 (20)* ³	ns	Figures 24.11 to 24.15
Write data hold time 1	t_{WDH1}	1	11	ns	Figures 24.11 to 24.15
Write data hold time	t_{WRH}	0	—	ns	Figures 24.11 to 24.14

Item	Symbol	Min.	Max.	Unit	Reference Figure
WAIT setup time	t_{WTS}	$1/2t_{Bcyc} + 17$ (18) ^{*3}	—	ns	Figures 24.12 to 24.15
WAIT hold time	t_{WTH}	$1/2t_{Bcyc} + 7$ (18) ^{*3}	—	ns	Figures 24.12 to 24.15

Notes: t_{Bcyc} indicates external bus clock time ($B\phi = CK$).

1. n denotes the number of wait cycles.
2. If the access time conditions are satisfied, the t_{RDS1} condition does not need to be satisfied.
3. Values in parentheses apply to E10A full-function F-ZTAT versions.

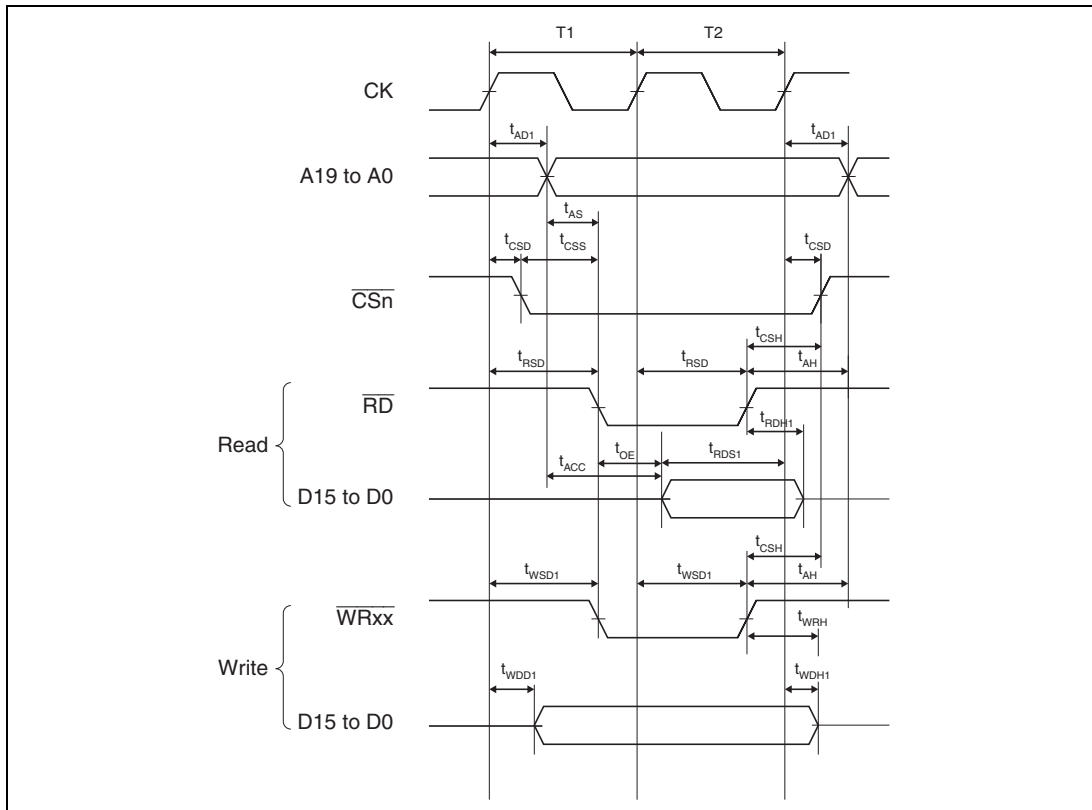

Figure 24.11 Basic Bus Timing for Normal Space (No Wait)

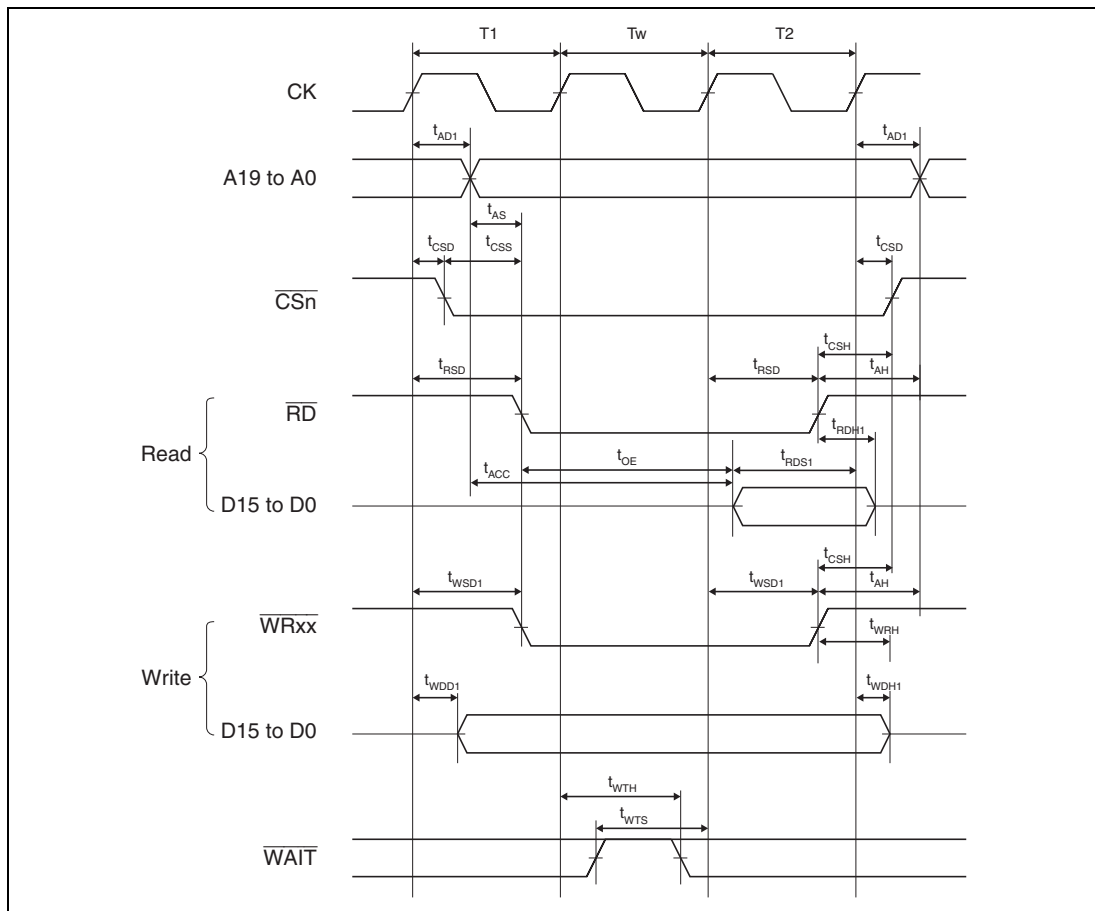

Figure 24.12 Basic Bus Timing for Normal Space (One Software Wait Cycle)

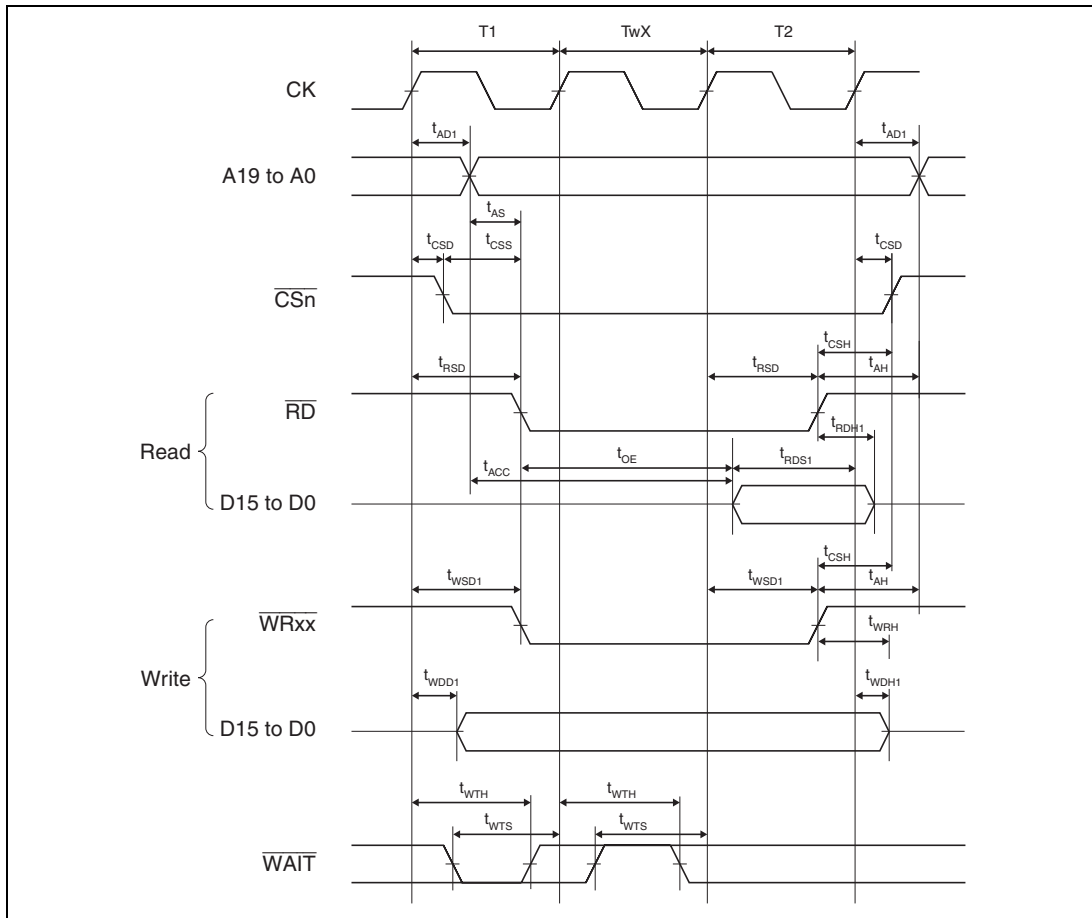
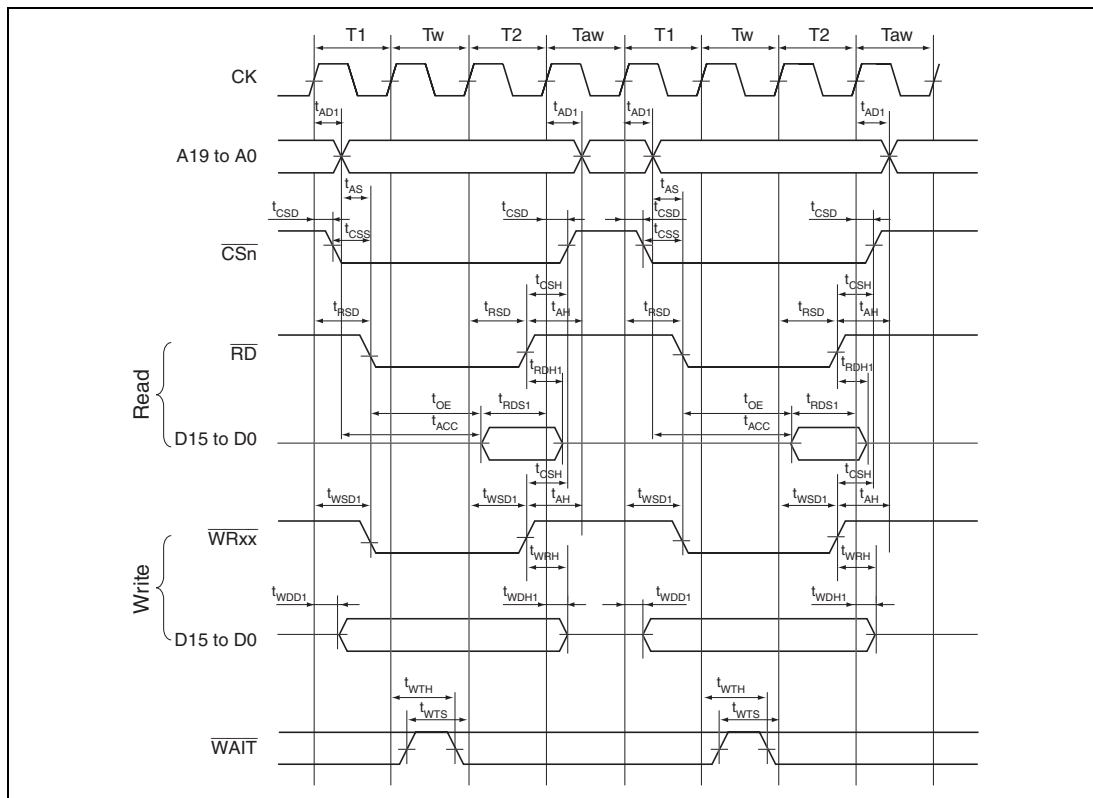
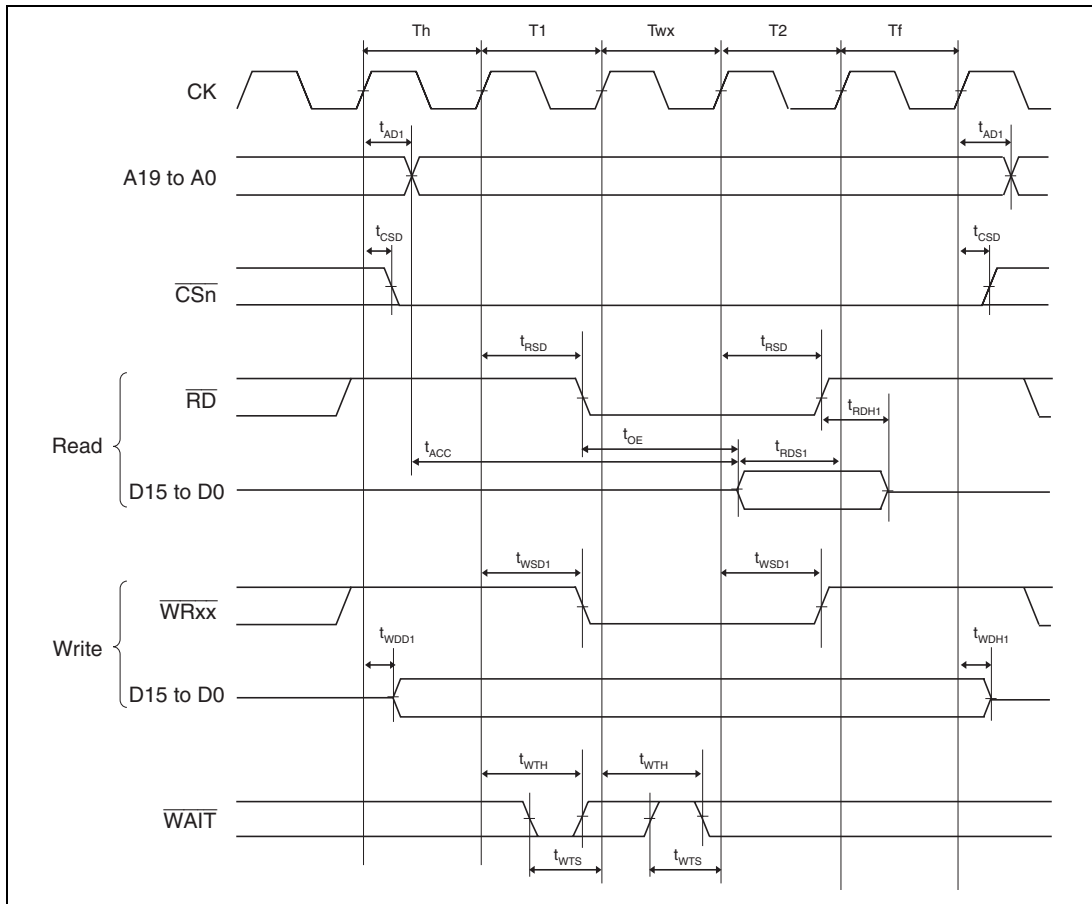

Figure 24.13 Basic Bus Timing for Normal Space (One External Wait Cycle)



**Figure 24.14 Basic Bus Timing for Normal Space
(One Software Wait Cycle, External Wait Cycle Valid (WM Bit = 0), No Idle Cycle)**



**Figure 24.15 CS Extended Bus Cycle for Normal Space
(SW = 1 Cycle, HW = 1 Cycle, One External Wait Cycle)**

24.3.4 Multi Function Timer Pulse Unit 2 (MTU2) Timing

Table 24.8 Multi Function Timer Pulse Unit 2 (MTU2) Timing

Conditions: $V_{CC} = 4.0\text{ V to }5.5\text{ V}$, $AV_{CC} = 4.0\text{ V to }5.5\text{ V}$, $V_{SS} = PLLV_{SS} = AV_{SS} = 0\text{ V}$,
 $T_a = -20^\circ\text{C to }+85^\circ\text{C}$ (consumer applications),
 $T_a = -40^\circ\text{C to }+85^\circ\text{C}$ (industrial applications)

Item	Symbol	Min.	Max.	Unit	Reference Figure
Output compare output delay time	t_{TOCD}	—	50	ns	Figure 24.16
Input capture input setup time	t_{TICS}	20	—	ns	
Input capture input pulse width (single edge)	t_{TICW}	1.5	—	$t_{MP\text{cyc}}$	
Input capture input pulse width (both edges)	t_{TICW}	2.5	—	$t_{MP\text{cyc}}$	
Timer input setup time	t_{TCKS}	20	—	ns	Figure 24.17
Timer clock pulse width (single edge)	$t_{TCKWH/L}$	1.5	—	$t_{MP\text{cyc}}$	
Timer clock pulse width (both edges)	$t_{TCKWH/L}$	2.5	—	$t_{MP\text{cyc}}$	
Timer clock pulse width (phase counting mode)	$t_{TCKWH/L}$	2.5	—	$t_{MP\text{cyc}}$	

Note: $t_{MP\text{cyc}}$ indicates the MTU2 clock ($MP\phi$) cycle.

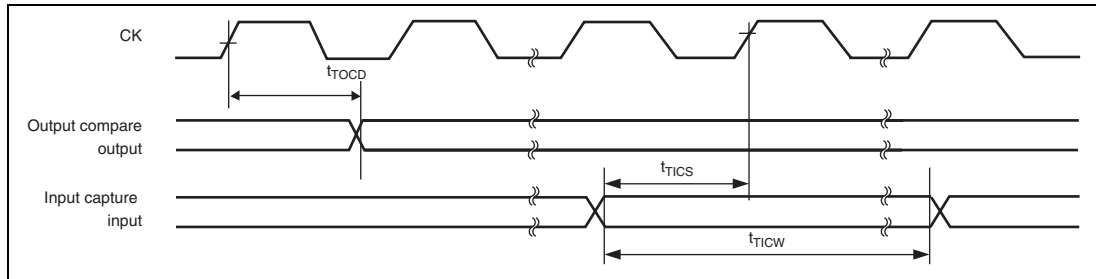

Figure 24.16 MTU2 Input/Output Timing

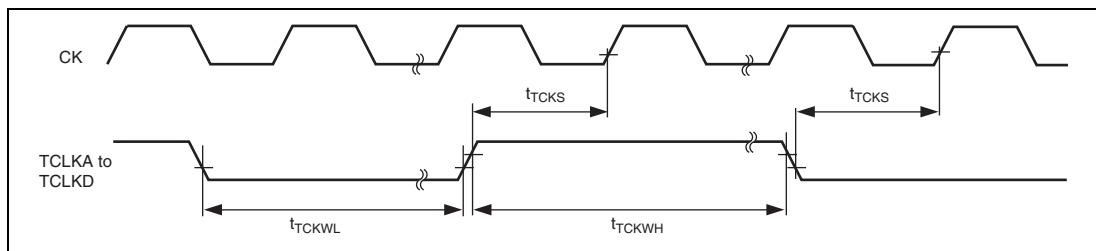

Figure 24.17 MTU2 Clock Input Timing

24.3.5 Multi Function Timer Pulse Unit 2S (MTU2S) Timing

Table 24.9 Multi Function Timer Pulse Unit 2S (MTU2S) Timing

Conditions: $V_{CC} = 4.0\text{ V to }5.5\text{ V}$, $AV_{CC} = 4.0\text{ V to }5.5\text{ V}$, $V_{SS} = PLLV_{SS} = AV_{SS} = 0\text{ V}$,
 $T_a = -20^\circ\text{C to }+85^\circ\text{C}$ (consumer applications),
 $T_a = -40^\circ\text{C to }+85^\circ\text{C}$ (industrial applications)

Item	Symbol	Min.	Max.	Unit	Reference Figure
Output compare output delay time	t_{TOCD}	—	50	ns	Figure 24.18
Input capture input setup time	t_{TICS}	20	—	ns	
Input capture input pulse width (single edge)	t_{TICW}	1.5	—	$t_{M\phi cyc}$	
Input capture input pulse width (both edges)	t_{TICW}	2.5	—	$t_{M\phi cyc}$	

Note: $t_{M\phi cyc}$ indicates the MTU2S clock ($M\phi$) cycle.

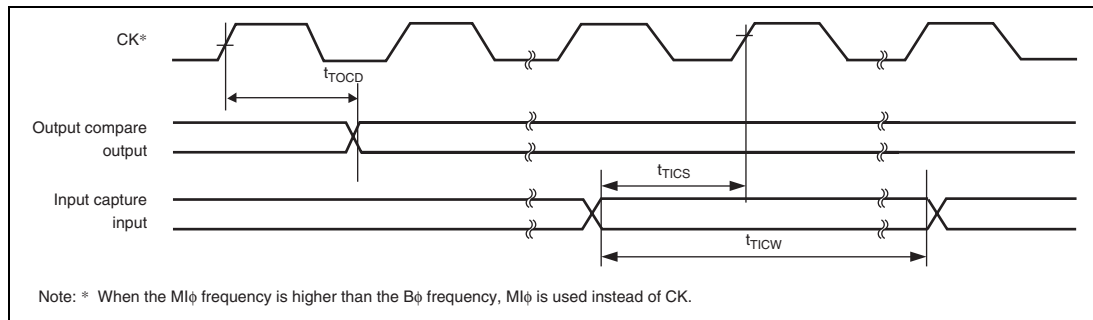

Figure 24.18 MTU2S Input/Output Timing

24.3.6 I/O Port Timing

Table 24.10 I/O Port Timing

Conditions: $V_{CC} = 4.0\text{ V to }5.5\text{ V}$, $AV_{CC} = 4.0\text{ V to }5.5\text{ V}$, $V_{SS} = PLLV_{SS} = AV_{SS} = 0\text{ V}$,
 $T_a = -20^\circ\text{C to }+85^\circ\text{C}$ (consumer applications),
 $T_a = -40^\circ\text{C to }+85^\circ\text{C}$ (industrial applications)

Item	Symbol	Min.	Max.	Unit	Reference Figure
Port output data delay time	t_{PVD}	—	50	ns	Figure 24.19
Port input hold time	t_{PRH}	20	—	ns	
Port input setup time	t_{PRS}	20	—	ns	

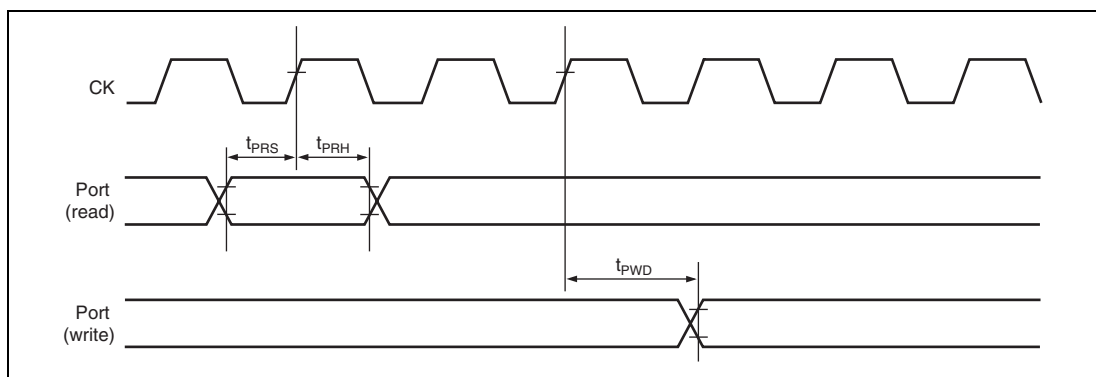

Figure 24.19 I/O Port Input/Output Timing

24.3.7 Watchdog Timer (WDT) Timing

Table 24.11 Watchdog Timer (WDT) Timing

Conditions: $V_{CC} = 4.0\text{ V to }5.5\text{ V}$, $AV_{CC} = 4.0\text{ V to }5.5\text{ V}$, $V_{SS} = PLLV_{SS} = AV_{SS} = 0\text{ V}$,
 $T_a = -20^\circ\text{C to }+85^\circ\text{C}$ (consumer applications),
 $T_a = -40^\circ\text{C to }+85^\circ\text{C}$ (industrial applications)

Item	Symbol	Min.	Max.	Unit	Reference Figure
$\overline{\text{WDTOVF}}$ delay time	t_{WOVD}	—	50	ns	Figure 24.20

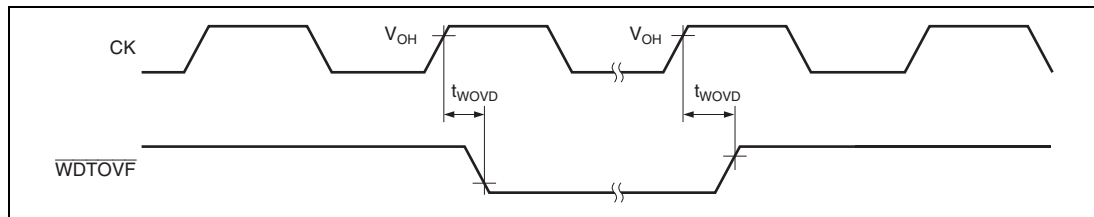

Figure 24.20 WDT Timing

24.3.8 Serial Communication Interface (SCI) Timing

Table 24.12 Serial Communication Interface (SCI) Timing

Conditions: $V_{CC} = 4.0\text{ V to }5.5\text{ V}$, $AV_{CC} = 4.0\text{ V to }5.5\text{ V}$, $V_{SS} = PLLV_{SS} = AV_{SS} = 0\text{ V}$,
 $T_a = -20^\circ\text{C to }+85^\circ\text{C}$ (consumer applications),
 $T_a = -40^\circ\text{C to }+85^\circ\text{C}$ (industrial applications)

Item		Symbol	Min.	Max.	Unit	Reference Figure
Input clock cycle (asynchronous)		t_{scyc}	4	—	$t_{p\text{cyc}}$	Figure 24.21
Input clock cycle (clock synchronous)		t_{scyc}	6	—	$t_{p\text{cyc}}$	
Input clock pulse width		t_{sckw}	0.4	0.6	$t_{s\text{cyc}}$	
Input clock rise time		t_{sckr}	—	1.5	$t_{p\text{cyc}}$	
Input clock fall time		t_{sckf}	—	1.5	$t_{p\text{cyc}}$	
Transmit data delay time	Asynchronous	t_{TXD}	—	$4 t_{p\text{cyc}} + 10$	ns	Figure 24.22
Receive data setup time		t_{RXS}	$4 t_{p\text{cyc}}$	—	ns	
Receive data hold time		t_{RXH}	$4 t_{p\text{cyc}}$	—	ns	
Transmit data delay time	Clock synchronous	t_{TXD}	—	$3 t_{p\text{cyc}} + 10$	ns	
Receive data setup time		t_{RXS}	$2 t_{p\text{cyc}} + 50$	—	ns	
Receive data hold time		t_{RXH}	$2 t_{p\text{cyc}}$	—	ns	

Note: $t_{p\text{cyc}}$ indicates the peripheral clock (P ϕ) cycle.

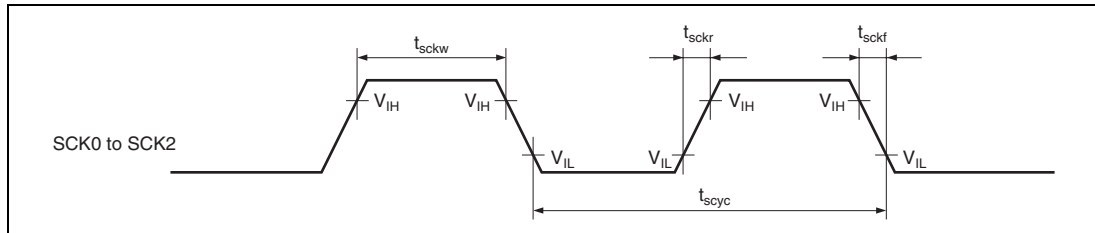

Figure 24.21 Input Clock Timing

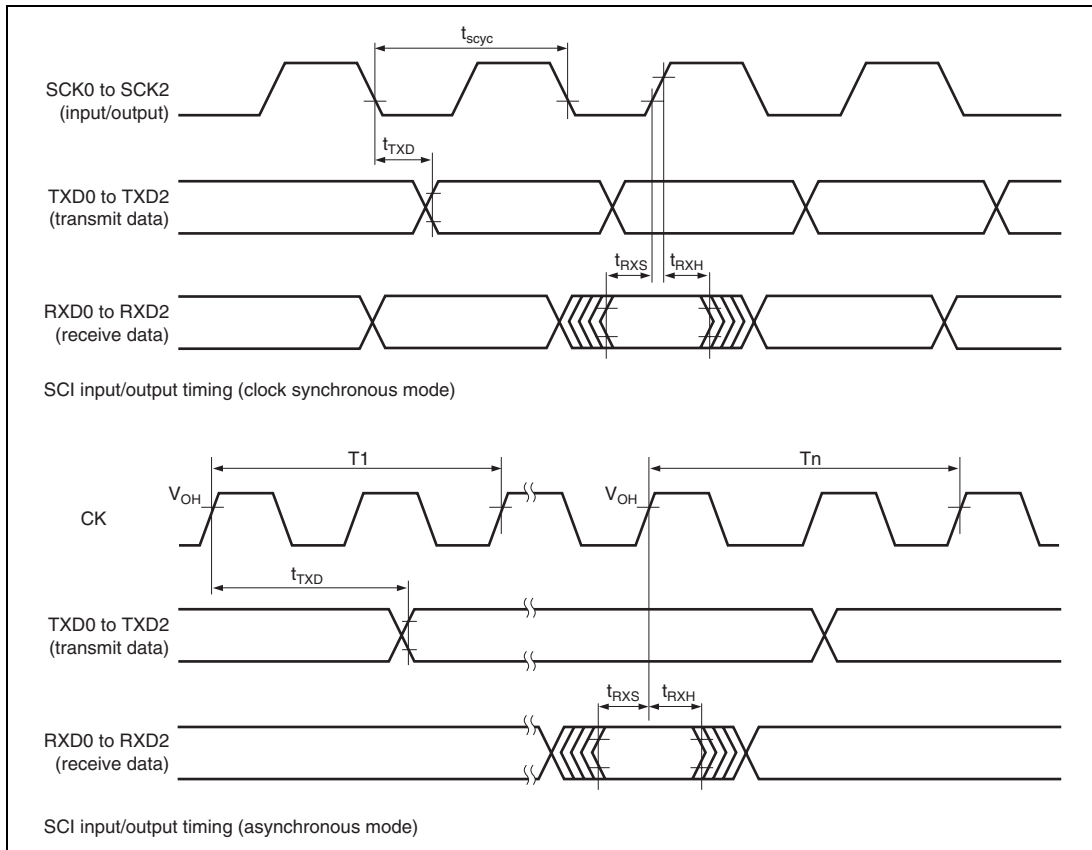

Figure 24.22 SCI Input/Output Timing

24.3.9 Port Output Enable (POE) Timing

Table 24.13 Port Output Enable (POE) Timing

Conditions: $V_{CC} = 4.0\text{ V to }5.5\text{ V}$, $AV_{CC} = 4.0\text{ V to }5.5\text{ V}$, $V_{SS} = PLLV_{SS} = AV_{SS} = 0\text{ V}$,
 $T_a = -20^\circ\text{C to }+85^\circ\text{C}$ (consumer applications),
 $T_a = -40^\circ\text{C to }+85^\circ\text{C}$ (industrial applications)

Item	Symbol	Min.	Max.	Unit	Reference Figure
$\overline{\text{POE}}$ input setup time	t_{POES}	50	—	ns	Figure 24.23
$\overline{\text{POE}}$ input pulse width	t_{POEW}	1.5	—	$t_{\text{p cyc}}$	

Note: $t_{\text{p cyc}}$ indicates the peripheral clock ($P\phi$) cycle.

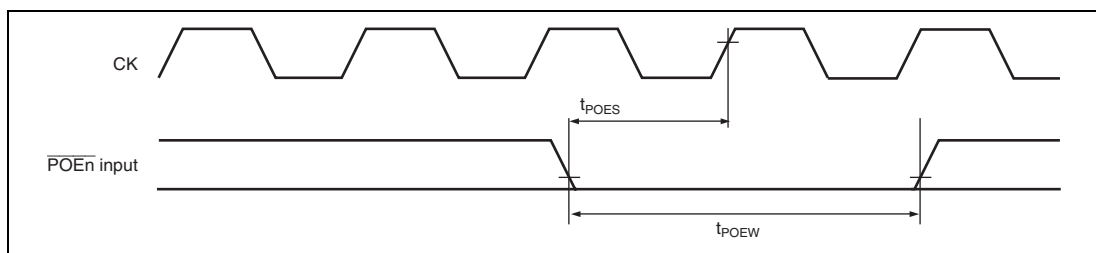

Figure 24.23 $\overline{\text{POE}}$ Input Timing

24.3.10 UBC Trigger Timing

Table 24.14 UBC Trigger Timing

Conditions: $V_{CC} = 4.0\text{ V to }5.5\text{ V}$, $AV_{CC} = 4.0\text{ V to }5.5\text{ V}$, $V_{SS} = PLLV_{SS} = AV_{SS} = 0\text{ V}$,
 $T_a = -20^\circ\text{C to }+85^\circ\text{C}$ (consumer applications),
 $T_a = -40^\circ\text{C to }+85^\circ\text{C}$ (industrial applications)

Item	Symbol	Min.	Max.	Unit	Reference Figure
$\overline{\text{UBCTR}}\overline{\text{G}}$ delay time	t_{UBCTGD}	—	150	ns	Figure 24.24

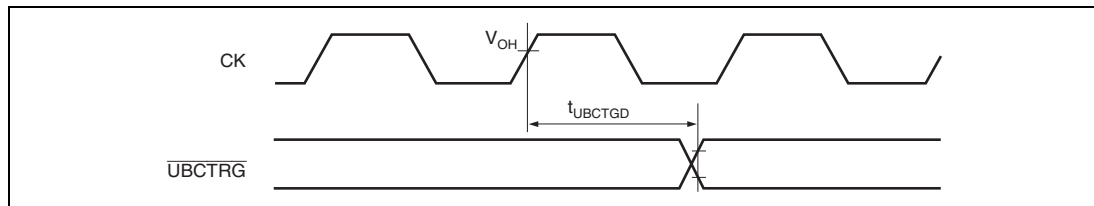

Figure 24.24 UBC Trigger Timing

24.3.11 A/D Converter Timing

Table 24.15 A/D Converter Timing

Conditions: $V_{CC} = 4.0\text{ V to }5.5\text{ V}$, $AV_{CC} = 4.0\text{ V to }5.5\text{ V}$, $V_{SS} = PLLV_{SS} = AV_{SS} = 0\text{ V}$,
 $T_a = -20^\circ\text{C to }+85^\circ\text{C}$ (consumer applications),
 $T_a = -40^\circ\text{C to }+85^\circ\text{C}$ (industrial applications)

Item	Symbol	Min.	Typ.	Max.	Unit	Figure
External trigger input start delay time	t_{TRGS}	25	—	—	ns	Figure 24.25

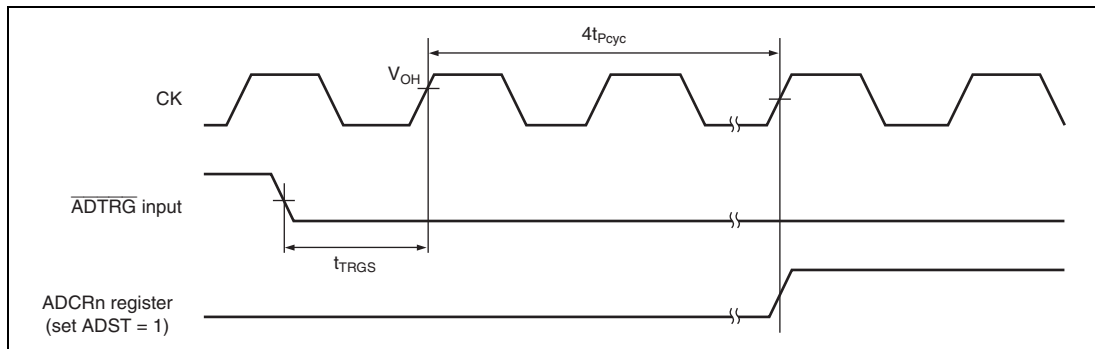

Figure 24.25 External Trigger Input Timing

24.3.12 AC Characteristics Measurement Conditions

- Input signal level: V_{IL} (Max.)/ V_{IH} (Min.)
- Output signal reference level: High level: 2.0 V, Low level: 0.8 V

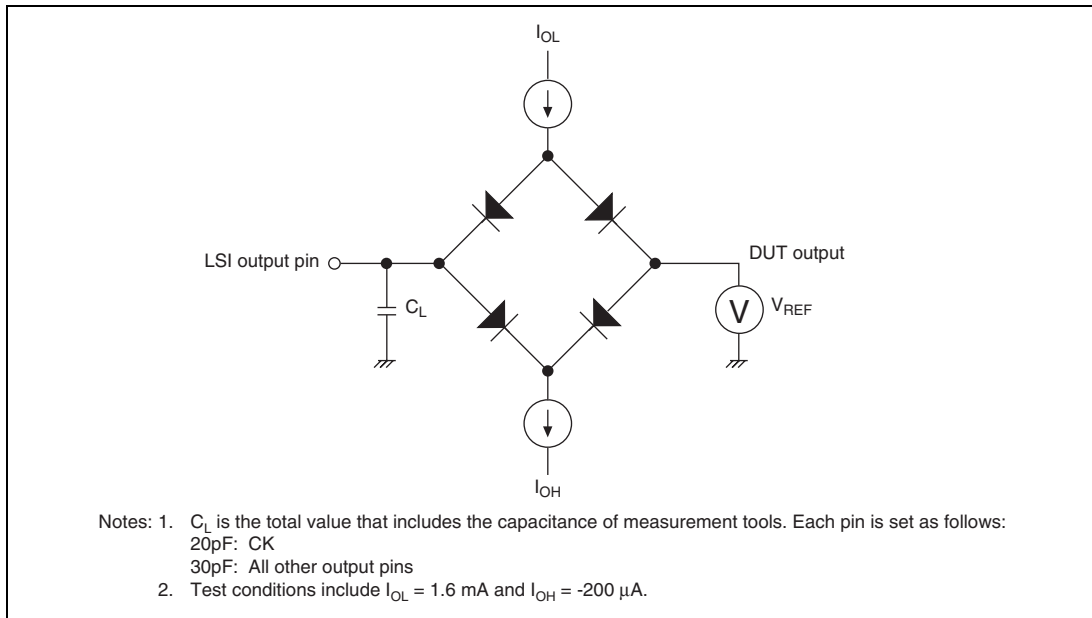

Figure 24.26 Output Load Circuit

24.4 A/D Converter Characteristics

Table 24.16 A/D Converter Characteristics

Conditions: $V_{CC} = 4.0\text{ V to }5.5\text{ V}$, $AV_{CC} = 4.0\text{ V to }5.5\text{ V}$, $V_{SS} = PLLV_{SS} = AV_{SS} = 0\text{ V}$,
 $T_a = -20^\circ\text{C to }+85^\circ\text{C}$ (consumer applications),
 $T_a = -40^\circ\text{C to }+85^\circ\text{C}$ (industrial applications)

Item	Min.	Typ.	Max.	Unit
Resolution	10	10	10	bit
A/D conversion time	2.0	—	—	μs
Analog input capacitance	—	—	20	pF
Permitted analog signal source impedance	—	—	$1^{*1}/3^{*2}$	k Ω
Non-linear error	—	—	$\pm 3.0^{*1}/\pm 5.0^{*2}$	LSB
Offset error	—	—	$\pm 3.0^{*1}/\pm 5.0^{*2}$	LSB
Full-scale error	—	—	$\pm 3.0^{*1}/\pm 5.0^{*2}$	LSB
Quantization error	—	—	± 0.5	LSB
Absolute error	—	—	$\pm 4.0^{*1}/\pm 6.0^{*2}$	LSB

Notes: 1. It is assumed that A/D conversion time $\geq 4.0\ \mu\text{s}$.
 2. It is assumed that A/D conversion time $< 4.0\ \mu\text{s}$.

24.5 Flash Memory Characteristics

Table 24.17 Flash Memory Characteristics

Conditions: $V_{CC} = 4.0\text{ V to }5.5\text{ V}$, $AV_{CC} = 4.0\text{ V to }5.5\text{ V}$, $V_{SS} = PLLV_{SS} = AV_{SS} = 0\text{ V}$,
 $T_a = -20^\circ\text{C to }+85^\circ\text{C}$ (consumer applications),
 $T_a = -40^\circ\text{C to }+85^\circ\text{C}$ (industrial applications)

Item	Symbol	Min.	Typ.	Max.	Unit
Programming time* ¹ * ² * ⁴	t_p	—	1	20	ms/128 bytes
Erase time* ¹ * ² * ⁴	t_E	—	40	260	ms/4-Kbyte block
		—	300	1500	ms/32-Kbyte block
		—	600	3000	ms/64-Kbyte block
Programming time (total)* ¹ * ² * ⁴	Σt_p	—	2.3	12	s/256 Kbytes
Erase time (total)* ¹ * ² * ⁴	Σt_E	—	2.3	12	s/256 Kbytes
Programming and erase time (total)* ¹ * ² * ⁴	Σt_{PE}	—	4.6	24	s/256 Kbytes
Reprogramming count	N_{WEC}	500* ³	—	—	Times

- Notes: 1. Programming and erase time vary depending on the data.
2. Programming and erase time do not include data transfer time.
3. The minimum number of times for which all characteristics are guaranteed after reprogramming (guaranteed for once to the minimum number of reprogramming times).
4. These characteristics only apply when reprogramming is performed within the range of minimum number of times.

24.6 Usage Note

24.6.1 Notes on Connecting V_{CL} Capacitor

This LSI includes an internal step-down circuit to automatically reduce the internal power supply voltage to an appropriate level. Between this internal stepped-down power supply (V_{CL} pin) and the V_{SS} pin, a capacitor (0.47 μF) for stabilizing the internal voltage needs to be connected. Connection of the external capacitor is shown in figure 24.27. The external capacitor should be located near the pin. Do not apply any power supply voltage to the V_{CL} pin.

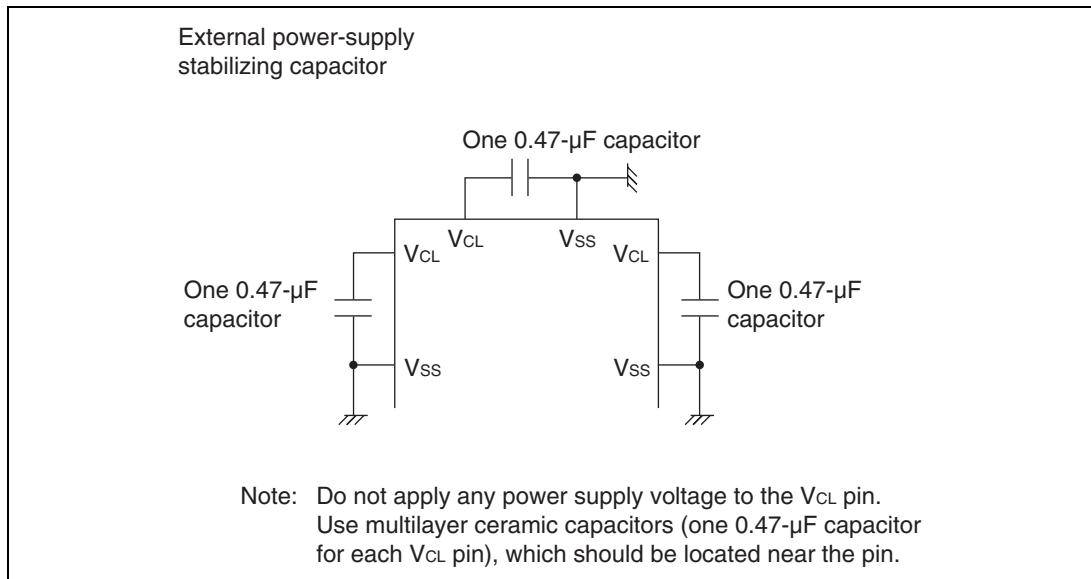

Figure 24.27 Connection of V_{CL} Capacitor

Appendix

A. Pin States

Pin initial states differ according to MCU operating modes. Refer to section 17, Pin Function Controller (PFC), for details.

Table A.1 Pin States (SH7146)

Pin Function		Pin State						
Type	Pin Name	Reset State		Power-Down State			Oscillation Stop Detected	POE Function Used
		Power-On	Manual	Deep Software Standby	Software Standby	Sleep		
Clock	XTAL	O	O	L	L	O	O	O
	EXTAL	I	I	Z	I	I	I	I
System control	$\overline{\text{RES}}$	I	I	I	I	I	I	I
	$\overline{\text{MRES}}$	Z	I	Z	Z	I	Z	I
	WDTOVF	O ^{*2}	O	O	O	O	O	O
Operating mode control	MD1	I	I	I	I	I	I	I
	$\overline{\text{ASEMD0}}$	I ^{*3}	I ^{*3}	I ^{*3}	I ^{*3}	I ^{*3}	I ^{*3}	I ^{*3}
	FWE	I	I	I	I	I	I	I
Interrupt	NMI	I	I	I	I	I	I	I
	IRQ0 to IRQ3	Z	I	Z	I	I	I	I
	IRQOUT	Z	O	Z	Z	O	Z	O
MTU2	TCLKA to TCLKD	Z	I	Z	Z	I	I	I
	TIOC0A to TIOC0D	Z	I/O	Z	K ^{*1}	I/O	I/O	Z
	TIOC1A, TIOC1B	Z	I/O	Z	K ^{*1}	I/O	I/O	I/O
	TIOC2A, TIOC2B	Z	I/O	Z	K ^{*1}	I/O	I/O	I/O
	TIOC3A, TIOC3C	Z	I/O	Z	K ^{*1}	I/O	I/O	I/O
	TIOC3B, TIOC3D	Z	I/O	Z	Z	I/O	Z	Z

Pin Function		Pin State						
Type	Pin Name	Reset State		Power-Down State			Oscillation Stop Detected	POE Function Used
		Power-On	Manual	Deep Software Standby	Software Standby	Sleep		
MTU2	TIOC4A to TIOC4D	Z	I/O	Z	Z	I/O	Z	Z
	TIC5U, TIC5V	Z	I	Z	Z	I	I	I
MTU2S	TIOC3BS, TIOC3DS	Z	I/O	Z	Z	I/O	Z	Z
	TIOC4AS to TIOC4DS	Z	I/O	Z	Z	I/O	Z	Z
	TIC5US, TIC5VS	Z	I	Z	Z	I	I	I
POE	POE0 to POE2, POE4 to POE6, POE8 (PA9)	Z	I	Z	Z	I	I	I
	POE3, POE7, POE8 (PB18)	I ^{*3}	I ^{*3}	Z	Z	I ^{*3}	I ^{*3}	I ^{*3}
SCI	SCK0 to SCK2	Z	I/O	Z	Z	I/O	I/O	I/O
	RXD0 to RXD2	Z	I	Z	Z	I	I	I
	TXD0 to TXD2	Z	O	Z	O ^{*1}	O	O	O
UBC	UBCTRG	Z	O	Z	O ^{*1}	O	O	O
A/D Converter	AN0, AN2, AN4, AN6, AN8 to AN15	Z	I	Z	Z	I	I	I
	ADTRG	Z	I	Z	Z	I	I	I
I/O Port	PA0 to PA15	Z	I/O	Z	K ^{*1}	I/O	I/O	I/O
	PB2 to PB5, PB16 to PB18	Z	I/O	Z	K ^{*1}	I/O	I/O	I/O
	PE0 to PE3	Z	I/O	Z	K ^{*1}	I/O	I/O	Z
	PE4 to PE8, PE10	Z	I/O	Z	K ^{*1}	I/O	I/O	I/O
	PE9, PE11 to PE15	Z	I/O	Z	Z	I/O	Z	Z
	PE16 to PE21	Z	I/O	Z	Z	I/O	Z	Z
	PF0, PF2, PF4, PF6, PF8 to PF15	Z	I	Z	Z	I	I	I

[Legend]

I: Input

O: Output

H: High-level output

L: Low-level output

Z: High-impedance

K: Input pins become high-impedance, and output pins retain their state.

- Notes:
1. Output pins become high-impedance when the HIZ bit in standby control register 6 (STBCR6) is set to 1.
 2. Becomes input during a power-on reset. Pull-up to prevent erroneous operation. Pull-down with a resistance of at least 1 M Ω as required.
 3. Pulled-up inside the LSI when there is no input.

Table A.2 Pin States (SH7149)

Pin Function		Pin State										
		Reset State					Power-Down State					
		Power-On					Power-Down State					
		Expansion without ROM			Single-chip	Manual	Deep Software Standby	Software Standby	Sleep	Bus Master-ship Release	Oscillation Stop Detected	POE Function Used
Type	Pin Name	8 bits	16 bits	with ROM	chip	Manual	Standby	Standby	Sleep	Release	Detected	Used
Clock	CK	O			Z	O	Z	H* ¹	O	O	O	O
	XTAL	O				O	L	L	O	O	O	O
	EXTAL	I				I	Z	I	I	I	I	I
System control	RES	I				I	I	I	I	I	I	I
	MRES	Z				I	Z	Z	I	I	Z	I
	WDTOVF	O* ³				O	O	O	O	O	O	O
	BREQ	Z				I	Z	Z	I	I	I	I
	BACK	Z				O	Z	Z	O	L	O	O
Operating mode control	MD0, MD1	I				I	I	I	I	I	I	I
	ASEMD0	I* ⁴				I* ⁴	I* ⁴	I* ⁴	I* ⁴	I* ⁴	I* ⁴	I* ⁴
	FWE	I				I	I	I	I	I	I	I
Interrupt	NMI	I				I	I	I	I	I	I	I
	IRQ0 to IRQ3	Z				I	Z	I	I	I	I	I
	IRQOUT	Z				O	Z	Z	O	O	Z	O
Address bus	A0 to A17	O	Z			O	Z	Z* ²	O	Z	O	O
	A18, A19	Z				O	Z	Z* ²	O	Z	O	O
Data bus	D0 to D15	Z				I/O	Z	Z	I/O	Z	I/O	I/O
Bus control	WAIT	Z				I	Z	Z	I	Z	I	I
	CS0 (PE10)	H	Z			O	Z	Z* ²	O	Z	O	O
	CS0 (PE17), CS1 (PE18)	Z				O	Z	Z* ²	O	Z	O	O
	RD (PA6)	H	Z			O	Z	Z* ²	O	Z	O	O
	RD (PE19)	Z				O	Z	Z* ²	O	Z	O	O
	WRH (PA7)	Z	H	Z		O	Z	Z* ²	O	Z	O	O

Pin Function		Pin State										
		Reset State					Power-Down State					
		Power-On					Power-Down					
		Expansion without ROM		Expansion	Single-chip	Manual	Deep Software Standby	Software Standby	Sleep	Bus Master-ship Release	Oscillation Stop Detected	POE Function Used
Type	Pin Name	8 bits	16 bits	with ROM	chip							
Bus control	WRL (PA8)	H	Z			O	Z	Z ^{*2}	O	Z	O	O
	WRH (PE20), WRL (PE21)	Z				O	Z	Z ^{*2}	O	Z	O	O
MTU2	TCLKA to TCLKD	Z				I	Z	Z	I	I	I	I
	TIOC0A to TIOC0D	Z				I/O	Z	K ^{*1}	I/O	I/O	I/O	Z
	TIOC1A, TIOC1B	Z				I/O	Z	K ^{*1}	I/O	I/O	I/O	I/O
	TIOC2A, TIOC2B	Z				I/O	Z	K ^{*1}	I/O	I/O	I/O	I/O
	TIOC3A, TIOC3C	Z				I/O	Z	K ^{*1}	I/O	I/O	I/O	I/O
	TIOC3B, TIOC3D	Z				I/O	Z	Z	I/O	I/O	Z	Z
	TIOC4A to TIOC4D	Z				I/O	Z	Z	I/O	I/O	Z	Z
	TIC5U, TIC5V, TIC5W	Z				I	Z	Z	I	I	I	I
MTU2S	TIOC3BS, TIOC3DS	Z				I/O	Z	Z	I/O	I/O	Z	Z
	TIOC4AS to TIOC4DS	Z				I/O	Z	Z	I/O	I/O	Z	Z
	TIC5US, TIC5VS, TIC5WS	Z				I	Z	Z	I	I	I	I
POE	POE0 to POE2, POE4 to POE6, POE8 (PA9)	Z				I	Z	Z	I	I	I	I
	POE3, POE7, POE8 (PB18)	I ^{*4}				I ^{*4}	Z	Z	I ^{*4}	I ^{*4}	I ^{*4}	I ^{*4}

Pin Function		Pin State										
		Reset State					Power-Down State					
Type	Pin Name	Power-On			Single-chip	Deep Software Standby			Bus Master-ship		Oscillation Stop Detected	POE Function Used
		Expansion without ROM	Expansion with ROM	8 bits		16 bits	Manual Standby	Software Standby	Sleep	Release		
SCI	SCK0 to SCK2	Z				I/O	Z	Z	I/O	I/O	I/O	I/O
	RXD0 to RXD2	Z				I	Z	Z	I	I	I	I
	TXD0 to TXD2	Z				O	Z	O ^{*1}	O	O	O	O
UBC	UBCTR \bar{G}	Z				O	Z	O ^{*1}	O	O	O	O
A/D Converter	AN0, AN2, AN4, AN6	Z				I	Z	Z	I	I	I	I
	ADTR \bar{G}	Z				I	Z	Z	I	I	I	I
I/O Port	PA0 to PA15	Z				I/O	Z	K ^{*1}	I/O	I/O	I/O	I/O
	PB0 to PB5, PB16 to PB18	Z				I/O	Z	K ^{*1}	I/O	I/O	I/O	I/O
	PD0 to PD15	Z				I/O	Z	K ^{*1}	I/O	I/O	I/O	I/O
	PE0 to PE3	Z				I/O	Z	K ^{*1}	I/O	I/O	I/O	Z
	PE4 to PE8, PE10	Z				I/O	Z	K ^{*1}	I/O	I/O	I/O	I/O
	PE9, PE11 to PE15	Z				I/O	Z	Z	I/O	I/O	Z	Z
	PE16 to PE21	Z				I/O	Z	Z	I/O	I/O	Z	Z
	PF0, PF2, PF4, PF6, PF8 to PF15	Z				I	Z	Z	I	I	I	I

[Legend]

I: Input

O: Output

H: High-level output

L: Low-level output

Z: High-impedance

K: Input pins become high-impedance, and output pins retain their state.

- Notes:
1. Output pins become high-impedance when the HIZ bit in standby control register 6 (STBCR6) is set to 1.
 2. Becomes output when the HIZMEM bit in the common control register (CMNCR) is set to 1.
 3. Becomes input during a power-on reset. Pull-up to prevent erroneous operation. Pull-down with a resistance of at least 1 M Ω as required.
 4. Pulled-up inside the LSI when there is no input.

B. Processing of Unused Pins

Table B.1 Processing of Unused Pins

Pin	Processing
NMI	Fixed high-level (pull-up)
WDTOVF	Open (If pull-down is necessary, use a resistor rated at 1 Ω or greater)
AVref	AVref = Avcc
AVcc, AVss	AVcc = Vcc, AVss = Vss
ASEMD0	Fixed high-level (pull-up)
PF0 to PF15	Connect to AVcc or AVss via a resistor
Input-only pins other than the above	Fixed (pull-up/pull-down)
I/O pins other than the above	Fixed at input pin setting (pull-up/pull-down) or set to output and left open
Output-only pins	Open

- Notes:
1. For pull-up or pull-down, connect to Vcc or GND via a resistor.
 2. When using the H-UDI, pin processing is according to the specifications of the emulator.

C. Pin States of Bus Related Signals

TableC.1 Pin States of Bus Related Signals (1)

Pin Name	On-chip ROM Space	On-chip RAM Space	On-chip Peripheral Module Space
$\overline{CS0}, \overline{CS1}$	H	H	H
\overline{RD}	R H	H	H
	W —	H	H
\overline{WRH}	R H	H	H
	W —	H	H
\overline{WRL}	R H	H	H
	W —	H	H
A19 to A0	Address*	Address*	Address*
D15 to D8	Hi-Z	Hi-Z	Hi-Z
D7 to D0	Hi-Z	Hi-Z	Hi-Z

[Legend]

R: Read

W: Write

Note: * Value of external space address that was previously accessed

Table C.1 Pin States of Bus Related Signals (2)

Pin Name	External Space (Normal Space)				
	8-bit Space		16-bit Space		
			Upper Byte	Lower Byte	Word/Longword
$\overline{CS0}, \overline{CS1}$	Enabled		Enabled	Enabled	Enabled
\overline{RD}	R	L	L	L	L
	W	H	H	H	H
\overline{WRH}	R	H	H	H	H
	W	H	L	H	L
\overline{WRL}	R	H	H	H	H
	W	L	H	L	L
A19 to A0	Address		Address	Address	Address
D15 to D8	Hi-Z		Data	Hi-Z	Data
D7 to D0	Data		Hi-Z	Data	Data

[Legend]

R: Read

W: Write

Enabled: Chip select signals corresponding to accessed areas = Low.
The other chip select signals = High.

D. Product Code Lineup

Table D.1 Product Code Lineup

Product Name	Classification	Product Type		Application	Operating temperature	Product Code	Package (Package Code)
		ROM Capacity	RAM Capacity				
SH7146	F-ZTAT version	256 kbytes	8 kbytes	Consumer application	-20 to +85°C	R5F71464AN80FPV	LQFP1414-80 (FP-80WV)
				Industrial application	-40 to +85°C	R5F71464AD80FPV	
	Masked ROM version	256 kbytes	8 kbytes	Consumer application	-20 to +85°C	R5M71464BNXXXFPV ^{*2}	
				Industrial application	-40 to +85°C	R5M71464BDXXXFPV ^{*2}	
	F-ZTAT version supporting full functions of E10A ^{*1}	256 kbytes	8 kbytes	For system development only ^{*1}	0 to +50°C	R5E71464RN80FPV	
	SH7149	F-ZTAT version	256 kbytes	8 kbytes	Consumer application	-20 to +85°C	R5F71494AN80FPV
Industrial application					-40 to +85°C	R5F71494AD80FPV	
Masked ROM version		256 kbytes	8 kbytes	Consumer application	-20 to +85°C	R5M71494BNXXXFPV ^{*2}	LQFP1414-100 (FP-100UV)
				Industrial application	-40 to +85°C	R5M71494BDXXXFPV ^{*2}	
F-ZTAT version supporting full functions of E10A ^{*1}		256 kbytes	8 kbytes	For system development only ^{*1}	0 to +50°C	R5E71494RN80FPV	LQFP1414-100 (FP-100UV)

- Notes: 1. These products are only used for system development by the customer, and E10A internal bus trace function and AUD function are available. However, normal F-ZTAT version or masked ROM version must be used in mass production.
In normal F-ZTAT version, the E10A internal bus trace function and AUD function are not available.
Reliability is not guaranteed for F-ZTAT version supporting full functions of E10A.
2. XXX is the ROM code.

E. Package Dimensions

The package dimension that is shown in the Renesas Semiconductor Package Data Book has priority.

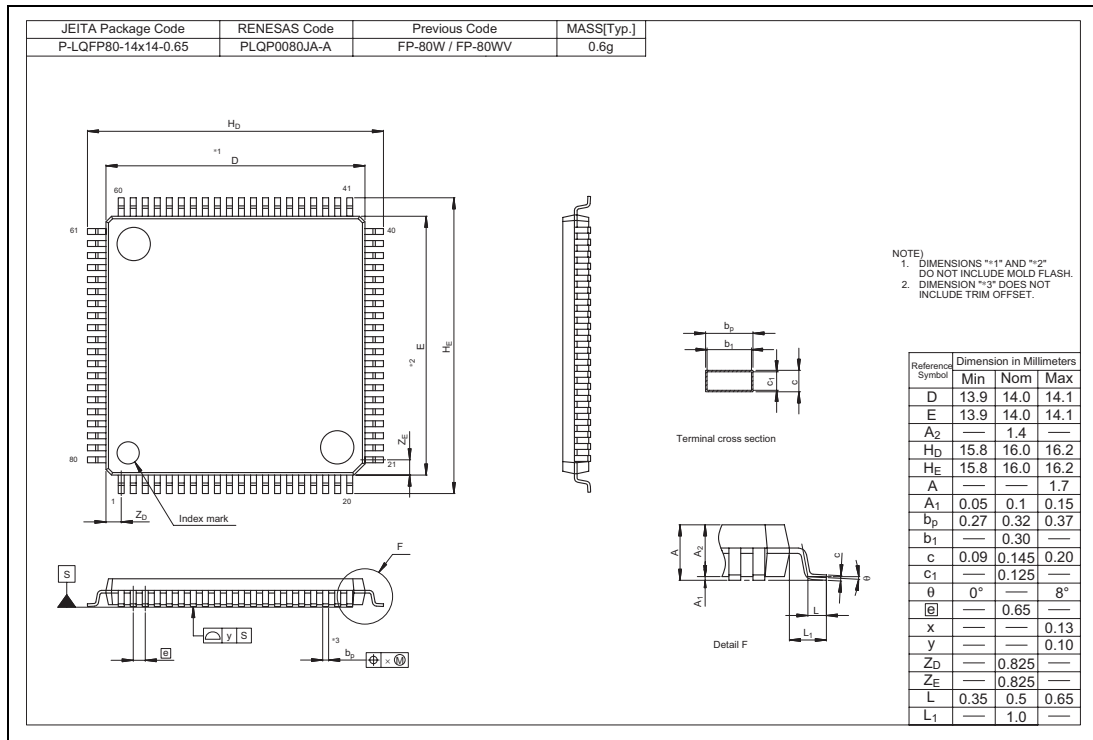

Figure E.1 FP-80WV

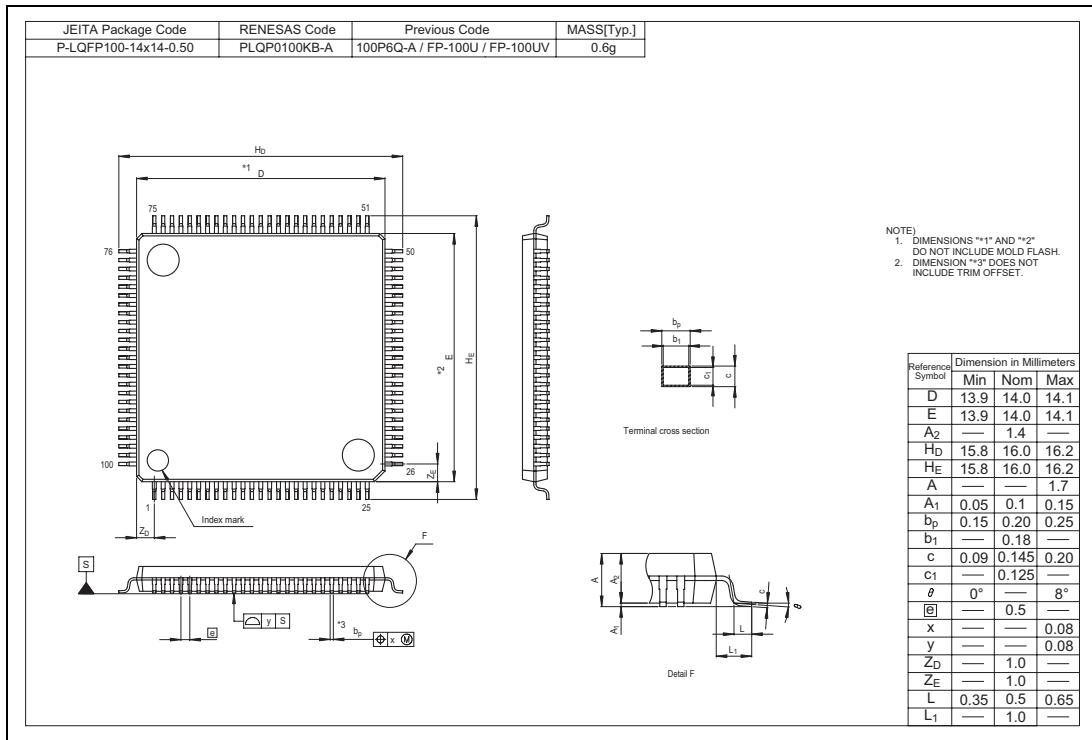

Figure E.2 FP-100UV

Main Revisions for This Edition

Item	Page	Revision (See Manual for Details)						
All	—	Company name and brand names amended (Before) Renesas Technology Corp. → (After) Renesas Electronics Corporation						
1.1 Features of SH7146 and SH7149 Table 1.1 Features	5	Table amended <table border="1"> <thead> <tr> <th>Items</th> <th>Specification</th> </tr> </thead> <tbody> <tr> <td>Packages</td> <td> <ul style="list-style-type: none"> • LQFP1414-80 (0.65 pitch) (SH7146) • LQFP1414-100 (0.5 pitch) (SH7149) </td> </tr> <tr> <td>Power supply voltage</td> <td> <ul style="list-style-type: none"> • Vcc: 4.0 to 5.5 V • AVcc: 4.0 to 5.5 V </td> </tr> </tbody> </table>	Items	Specification	Packages	<ul style="list-style-type: none"> • LQFP1414-80 (0.65 pitch) (SH7146) • LQFP1414-100 (0.5 pitch) (SH7149) 	Power supply voltage	<ul style="list-style-type: none"> • Vcc: 4.0 to 5.5 V • AVcc: 4.0 to 5.5 V
Items	Specification							
Packages	<ul style="list-style-type: none"> • LQFP1414-80 (0.65 pitch) (SH7146) • LQFP1414-100 (0.5 pitch) (SH7149) 							
Power supply voltage	<ul style="list-style-type: none"> • Vcc: 4.0 to 5.5 V • AVcc: 4.0 to 5.5 V 							
1.3 Pin Assignments Figure 1.4 Pin Assignments of SH7149 (QFP Version)	—	Figure deleted						
5.8.4 Notes on Slot Illegal Instruction Exception Handling	—	Description deleted Note that a check-up program (checker) to pick up this instruction is available on our website. Download and utilize this checker as needed.						
8.7.2 Chain Transfer when Counter = 0	193	Description amended <ol style="list-style-type: none"> Execute the first data transfer 65536 times by means of interrupts. When the transfer counter for the first data transfer reaches 0, the second data transfer is started. Set the upper eight bits of the transfer destination address for the first data transfer to H'21. The lower 16 bits of the transfer destination address of the first data transfer and the transfer counter are H'0000. Next, execute the first data transfer the 65536 times specified for the first data transfer by means of interrupts. When the transfer counter for the first data transfer reaches 0, the second data transfer is started. Set the upper eight bits of the transfer destination address for the first data transfer to H'20. The lower 16 bits of the transfer destination address of the first data transfer and the transfer counter are H'0000. 						

Item	Page	Revision (See Manual for Details)
------	------	-----------------------------------

9.5.10 Access to External Memory by CPU

233

Table amended

Table 9.11 Number of External Access Cycles

External Bus Width	Access Size	Write/Read	Number of Access Cycles
8 bits	Byte	Write	$(1 + n) \times l\phi + (3 + m) \times B\phi$
		Read	$(1 + n) \times l\phi + (3 + m) \times B\phi + 1 \times l\phi$
	Word	Write	$(1 + n) \times l\phi + (3 + m) \times B\phi + 1 \times (2 + o) \times B\phi$
		Read	$(1 + n) \times l\phi + (3 + m) \times B\phi + 1 \times (2 + o) \times B\phi + 1 \times l\phi$
	Longword	Write	$(1 + n) \times l\phi + (3 + m) \times B\phi + 3 \times (2 + o) \times B\phi$
		Read	$(1 + n) \times l\phi + (3 + m) \times B\phi + 3 \times (2 + o) \times B\phi + 1 \times l\phi$
16 bits	Byte/Word	Write	$(1 + n) \times l\phi + (3 + m) \times B\phi$
		Read	$(1 + n) \times l\phi + (3 + m) \times B\phi + 1 \times l\phi$
	Longword	Write	$(1 + n) \times l\phi + (3 + m) \times B\phi + 1 \times (2 + o) \times B\phi$
		Read	$(1 + n) \times l\phi + (3 + m) \times B\phi + 1 \times (2 + o) \times B\phi + 1 \times l\phi$

10.3.32 Timer Waveform Control Register (TWCR) 326

Bit table amended

Bit	Bit Name	Initial Value	R/W	Description
0	WRE	0	R/(W)	<p>Initial Output Suppression Enable</p> <p>Selects the waveform output when synchronous counter clearing occurs in complementary PWM mode. The initial output is suppressed only when synchronous clearing occurs within the Tb interval at the trough in complementary PWM mode. When synchronous clearing occurs outside this interval, the initial value specified in TOCR is output regardless of the WRE bit setting. The initial value is also output when synchronous clearing occurs in the Tb interval at the trough immediately after TCNT_3 and TCNT_4 start operation.</p> <p>For the Tb interval at the trough in complementary PWM mode, see figure 10.40.</p> <p>0: Outputs the initial value specified in TOCR 1: Suppresses initial output [Setting condition]</p> <ul style="list-style-type: none"> When 1 is written to WRE after reading WRE = 0

Item	Page	Revision (See Manual for Details)
10.4.8 Complementary PWM Mode Outline of Complementary PWM Mode Operation:	381	<p>Description added</p> <p>14. Output Waveform Control at Synchronous Counter Clearing in Complementary PWM Mode</p> <p>Setting the WRE bit in TWCR to 1 suppresses initial output when synchronous counter clearing occurs in the Tb interval at the trough in complementary PWM mode and controls abrupt change in duty cycle at synchronous counter clearing.</p> <p>Initial output suppression is applicable only when synchronous clearing occurs in the Tb interval at the trough as indicated by (10) or (11) in figure 10.56. When synchronous clearing occurs outside that interval, the initial value specified by the OLS bits in TOCR is output. Even in the Tb interval at the trough, if synchronous clearing occurs in the initial value output period (indicated by (1) in figure 10.56) immediately after the counters start operation, initial value output is not suppressed.</p> <p>When using the initial output suppression function, make sure to set compare registers TGRB_3, TGRA_4, and TGRB_4 to a value twice or more the setting of dead time data register TDDR. If synchronous clearing occurs with the compare registers set to a value less than twice the setting of TDDR, the PWM output dead time may be too short (or nonexistent) or illegal active-level PWM negative-phase output may occur during the initial output suppression interval. For details, see 10.7.23, Notes on Output Waveform Control During Synchronous Counter Clearing in Complementary PWM Mode.</p> <p>This function can be used in both the MTU2 and MTU2S...</p>
Figure 10.77 Example of Operation when Buffer Transfer is Linked with Interrupt Skipping (BTE1 = 1 and BTE0 = 0)	401	Figure replaced
Figure 10.78 Relationship between Bits T3AEN and T4VEN in TITCR and Buffer Transfer-Enabled Period	402	Figure replaced

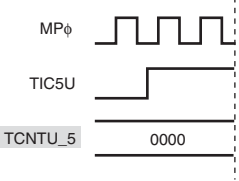
Item	Page	Revision (See Manual for Details)																																				
10.4.11 External Pulse Width Measurement Figure 10.88 Example of External Pulse Width Measurement (Measuring High Pulse Width)	414	Figure amended 																																				
10.7.23 Notes on Output Waveform Control During Synchronous Counter Clearing in Complementary PWM Mode	451, 452	Newly added																																				
Section 11 Multi-Function Timer Pulse Unit 2S (MTU2S) Table 11.1 MTU2S Functions	486	Table amended <table border="1" data-bbox="742 705 1316 772"> <thead> <tr> <th>Item</th> <th>Channel 3</th> <th>Channel 4</th> <th>Channel 5</th> </tr> </thead> <tbody> <tr> <td>PWM mode 1</td> <td>—</td> <td>—</td> <td>—</td> </tr> <tr> <td>PWM mode 2</td> <td>—</td> <td>—</td> <td>—</td> </tr> </tbody> </table>	Item	Channel 3	Channel 4	Channel 5	PWM mode 1	—	—	—	PWM mode 2	—	—	—																								
Item	Channel 3	Channel 4	Channel 5																																			
PWM mode 1	—	—	—																																			
PWM mode 2	—	—	—																																			
13.5 Interrupt Source	532	Newly added																																				
14.3.8 Serial Port Register (SCSPTR)	550	Bit table amended <table border="1" data-bbox="742 873 1316 985"> <thead> <tr> <th>Bit:</th> <th>7</th> <th>6</th> <th>5</th> <th>4</th> <th>3</th> <th>2</th> <th>1</th> <th>0</th> </tr> </thead> <tbody> <tr> <td></td> <td>EIO</td> <td>-</td> <td>-</td> <td>-</td> <td>SPB1IO</td> <td>SPB1DT</td> <td>SPB0IO</td> <td>SPB0DT</td> </tr> <tr> <td>Initial value:</td> <td>0</td> <td>0</td> <td>0</td> <td>0</td> <td>0</td> <td>-</td> <td>0</td> <td>1</td> </tr> <tr> <td>R/W:</td> <td>R/W</td> <td>-</td> <td>-</td> <td>-</td> <td>R/W</td> <td>R/W</td> <td>R/W</td> <td>R/W</td> </tr> </tbody> </table>	Bit:	7	6	5	4	3	2	1	0		EIO	-	-	-	SPB1IO	SPB1DT	SPB0IO	SPB0DT	Initial value:	0	0	0	0	0	-	0	1	R/W:	R/W	-	-	-	R/W	R/W	R/W	R/W
Bit:	7	6	5	4	3	2	1	0																														
	EIO	-	-	-	SPB1IO	SPB1DT	SPB0IO	SPB0DT																														
Initial value:	0	0	0	0	0	-	0	1																														
R/W:	R/W	-	-	-	R/W	R/W	R/W	R/W																														
	551	<table border="1" data-bbox="742 1008 1316 1366"> <thead> <tr> <th>Bit</th> <th>Bit Name</th> <th>Initial value</th> <th>R/W</th> <th>Description</th> </tr> </thead> <tbody> <tr> <td>0</td> <td>SPB0DT</td> <td>1</td> <td>R/W</td> <td>Serial Port Break Data Together with the SPB0IO bit and TE bit in SCSCR, controls the TXD pin. Note that the TXD pin function needs to have been selected with the pin function controller (PFC). <table border="1" data-bbox="981 1131 1300 1355"> <thead> <tr> <th>TE bit setting in SCSCR</th> <th>SPB0IO setting</th> <th>SPB0DT bit setting</th> <th>State of TXD pin</th> </tr> </thead> <tbody> <tr> <td>0</td> <td>0</td> <td>*</td> <td>SPB0DT output disabled (initial state)</td> </tr> <tr> <td>0</td> <td>1</td> <td>0</td> <td>Output, low level</td> </tr> <tr> <td>0</td> <td>1</td> <td>1</td> <td>Output, high level</td> </tr> <tr> <td>1</td> <td>*</td> <td>*</td> <td>Output for transmit data in accord with the serial core logic</td> </tr> </tbody> </table> </td> </tr> </tbody> </table> <p>Note: * Don't care</p>	Bit	Bit Name	Initial value	R/W	Description	0	SPB0DT	1	R/W	Serial Port Break Data Together with the SPB0IO bit and TE bit in SCSCR, controls the TXD pin. Note that the TXD pin function needs to have been selected with the pin function controller (PFC). <table border="1" data-bbox="981 1131 1300 1355"> <thead> <tr> <th>TE bit setting in SCSCR</th> <th>SPB0IO setting</th> <th>SPB0DT bit setting</th> <th>State of TXD pin</th> </tr> </thead> <tbody> <tr> <td>0</td> <td>0</td> <td>*</td> <td>SPB0DT output disabled (initial state)</td> </tr> <tr> <td>0</td> <td>1</td> <td>0</td> <td>Output, low level</td> </tr> <tr> <td>0</td> <td>1</td> <td>1</td> <td>Output, high level</td> </tr> <tr> <td>1</td> <td>*</td> <td>*</td> <td>Output for transmit data in accord with the serial core logic</td> </tr> </tbody> </table>	TE bit setting in SCSCR	SPB0IO setting	SPB0DT bit setting	State of TXD pin	0	0	*	SPB0DT output disabled (initial state)	0	1	0	Output, low level	0	1	1	Output, high level	1	*	*	Output for transmit data in accord with the serial core logic						
Bit	Bit Name	Initial value	R/W	Description																																		
0	SPB0DT	1	R/W	Serial Port Break Data Together with the SPB0IO bit and TE bit in SCSCR, controls the TXD pin. Note that the TXD pin function needs to have been selected with the pin function controller (PFC). <table border="1" data-bbox="981 1131 1300 1355"> <thead> <tr> <th>TE bit setting in SCSCR</th> <th>SPB0IO setting</th> <th>SPB0DT bit setting</th> <th>State of TXD pin</th> </tr> </thead> <tbody> <tr> <td>0</td> <td>0</td> <td>*</td> <td>SPB0DT output disabled (initial state)</td> </tr> <tr> <td>0</td> <td>1</td> <td>0</td> <td>Output, low level</td> </tr> <tr> <td>0</td> <td>1</td> <td>1</td> <td>Output, high level</td> </tr> <tr> <td>1</td> <td>*</td> <td>*</td> <td>Output for transmit data in accord with the serial core logic</td> </tr> </tbody> </table>	TE bit setting in SCSCR	SPB0IO setting	SPB0DT bit setting	State of TXD pin	0	0	*	SPB0DT output disabled (initial state)	0	1	0	Output, low level	0	1	1	Output, high level	1	*	*	Output for transmit data in accord with the serial core logic														
TE bit setting in SCSCR	SPB0IO setting	SPB0DT bit setting	State of TXD pin																																			
0	0	*	SPB0DT output disabled (initial state)																																			
0	1	0	Output, low level																																			
0	1	1	Output, high level																																			
1	*	*	Output for transmit data in accord with the serial core logic																																			

Item	Page	Revision (See Manual for Details)
------	------	-----------------------------------

14.4.3 Clock Synchronous Mode	584	Figure amended
-------------------------------	-----	----------------

Figure 14.14 Sample Flowchart for Transmitting/Receiving Serial Data

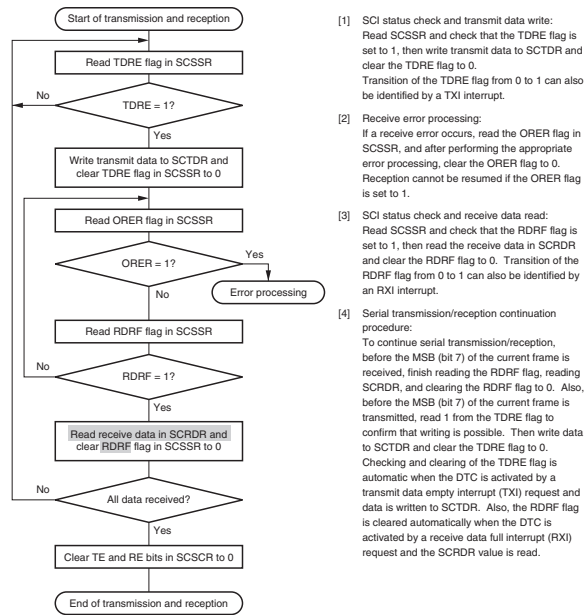

- [1] SCI status check and transmit data write:
Read SCSSR and check that the TDRE flag is set to 1, then write transmit data to SCTDR and clear the TDRE flag to 0.
Transition of the TDRE flag from 0 to 1 can also be identified by a TXI interrupt.
- [2] Receive error processing:
If a receive error occurs, read the ORE flag in SCSSR, and after performing the appropriate error processing, clear the ORE flag to 0. Reception cannot be resumed if the ORE flag is set to 1.
- [3] SCI status check and receive data read:
Read SCSSR and check that the RDRF flag is set to 1, then read the receive data in SCRDR and clear the RDRF flag to 0. Transition of the RDRF flag from 0 to 1 can also be identified by an RXI interrupt.
- [4] Serial transmission/reception continuation procedure:
To continue serial transmission/reception, before the MSB (bit 7) of the current frame is received, finish reading the RDRF flag, reading SCRDR, and clearing the RDRF flag to 0. Also, before the MSB (bit 7) of the current frame is transmitted, read 1 from the TDRE flag to confirm that writing is possible. Then write data to SCTDR and clear the TDRE flag to 0. Checking and clearing of the TDRE flag is automatic when the DTC is activated by a transmit data empty interrupt (TXI) request and data is written to SCTDR. Also, the RDRF flag is cleared automatically when the DTC is activated by a receive data full interrupt (RXI) request and the SCRDR value is read.

Note: When switching from transmit or receive operation to simultaneous transmit and receive operations, first clear the TE bit and RE bit to 0, then set both these bits to 1 simultaneously.

14.4.5 Multiprocessor Serial Data Transmission	586	Description amended
--	-----	---------------------

Description amended

Figure 14.16 shows a sample flowchart for multiprocessor serial data transmission. For an ID transmission cycle, set the MPBT bit in SCSSR to 1 before transmission. Maintain the MPBT value at 1 until the ID transmission actually completes. For a data transmission cycle, clear the MPBT bit in SCSSR to 0 before transmission. All other SCI operations are the same as those in asynchronous mode.

Item **Page** **Revision (See Manual for Details)**

14.4.5 Multiprocessor Serial Data Transmission
 Figure 14.16 Sample Multiprocessor Serial Transmission Flowchart

Figure amended

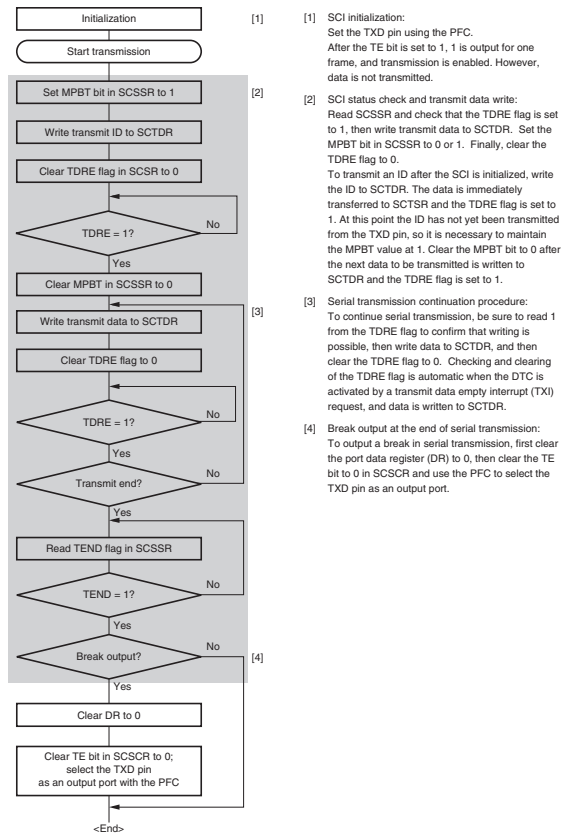

14.5 SCI Interrupt Sources and DTC 591

Description amended

When the ORER, FER, or PER flag in SCSSR is set to 1, an ERI interrupt request is generated. This request cannot be used to activate the DTC. It is possible to disable generation of RXI interrupt requests and allow only ERI interrupt requests to be generated during data reception processing. To accomplish this, set the RIE bit to 1 and the EIO bit in SCSPTR to 1. Note that setting the EIO bit to 1 will prevent the DTC from transferring received data because no ERI interrupt requests are generated.

Item Page Revision (See Manual for Details)

15.3.4 A/D Trigger Select Registers_0 and _1 (ADTSR_0 and ADTSR_1)

613 Bit table amended

- ADTSR_0

Bit	Bit Name	Initial Value	R/W	Description
7 to 4	TRG1S[3:0]	0000	R/W	A/D Trigger 1 Select 3 to 0 Select an external trigger, MTU2 trigger, or MTU2S trigger to start A/D conversion for A/D module 1. In 2-channel scan mode, these bits select an external trigger, MTU2 trigger, or MTU2S trigger to start A/D conversion for group 0. 0000: External trigger pin (ADTRG) input 0001: TGRA input capture/compare match for each MTU2 channel or TCNT_4 trough in complementary PWM mode (TRGAN) 0010: MTU2 CH0 compare match (TRGON) 0011: MTU2 A/D conversion start request delaying (TRG4AN) 0100: MTU2 A/D conversion start request delaying (TRG4BN) 0101: TGRA input capture/compare match on each MTU2S channel or TCNT_4 trough in complementary PWM mode (TRGAN) 0110: Setting prohibited 0111: MTU2S A/D conversion start request delaying (TRG4AN) 1000: MTU2S A/D conversion start request delaying (TRG4BN) 1001: Setting prohibited 101x: Setting prohibited 11xx: Setting prohibited When switching the selector, first clear the ADST bit in the A/D control register (ADCR) to 0. Specify different trigger sources for the group 0 and group 1 conversion requests so that a group 0 conversion request is not generated simultaneously with a group 1 conversion request in 2-channel scan mode.

15.4.7 2-Channel Scanning
Figure 15.4 Example of 2-Channel Scanning

621 Figure amended

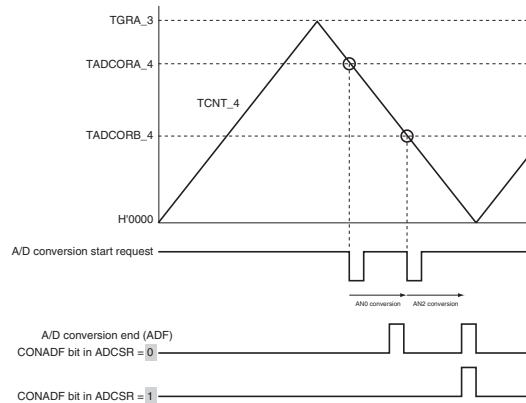

16.4 Interrupts

635 Description and Table added

16.4.1 CMT Interrupt Sources and DTC Activation

....

Table 16.2 Interrupt Source

The data transfer controller (DTC) can be activated by an interrupt request. In this case, the priority between channels is fixed. See section 8, Data Transfer Controller (DTC), for details.

Table 16.2 lists the CMT interrupt sources.

Item	Page	Revision (See Manual for Details)
19.4.3 Programming/Erasing Interface Parameters	758	Description amended (2.1) Flash programming/erasing frequency parameter (FPEFEQ: general register R4 of CPU) This parameter sets the operating frequency of the CPU. For the range of the operating frequency of this LSI, see table 24.4, Maximum Operating Frequency.
19.9.1 Specifications of the Standard Serial Communications Interface in Boot Mode (2) Device selection	808	Description amended — Size (1 byte): Number of characters in the device code (fixed at 4)
22.8.2 Deep Software Standby Mode	—	Description deleted
24.2 DC Characteristics Table 24.2 DC Characteristics	907, 908	Table amended

Item	Symbol	Min.	Typ.	Max.	Unit	Test Conditions		
Three-state leak current (OFF state)	Ports A, B, D, E $ I_{le} $	—	—	1.0	μA			
Output high-level voltage	All output pins	V_{OH}	$V_{CC} - 0.5$	—	—	V	$I_{OH} = -200 \mu\text{A}$	
			$V_{CC} - 1.0$	—	—	V	$I_{OH} = -1 \text{ mA}$	
		TIOC3B, TIOC3D, TIOC4A to TIOC4D, TIOC3BS, TIOC3DS, TIOC4AS to TIOC4DS	V_{OH}	$V_{CC} - 1.0$	—	—	V	$I_{OH} = -5 \text{ mA}$
				PE9, PE11 to PE21	$V_{CC} - 2.0$	—	—	V
Output low-level voltage	All output pins	V_{OL}	—	—	0.4	V	$I_{OL} = 1.6 \text{ mA}$	
			—	—	1.4	V	$I_{OL} = 15 \text{ mA}$	
		TIOC3B, TIOC3D, TIOC4A to TIOC4D, TIOC3BS, TIOC3DS, TIOC4AS to TIOC4DS	V_{OL}	—	—	1.4	V	$I_{OL} = 15 \text{ mA}$
				PE9, PE11 to PE21	—	—	2.5	V
Input capacitance	All input pins C_i	—	—	20	pF	$V_i = 0 \text{ V}$ $f = 1 \text{ MHz}$ $T_a = 25^\circ\text{C}$		
Supply current	Normal operation	I_{CC}	—	80	125	mA	$I_0 = 80 \text{ MHz}$ $B_0 = 40 \text{ MHz}$ $P_0 = 40 \text{ MHz}$ $MP_0 = 40 \text{ MHz}$ $MI_0 = 80 \text{ MHz}$	
			—	65	110	mA	$B_0 = 40 \text{ MHz}$ $P_0 = 40 \text{ MHz}$ $MP_0 = 40 \text{ MHz}$ $MI_0 = 80 \text{ MHz}$	
			—	10	40	mA	$T_i \leq 50^\circ\text{C}$	
			—	80	—	mA	$50^\circ\text{C} < T_i$	
			—	5	30	μA	$T_i \leq 50^\circ\text{C}$	
Supply current Only in F-ZTAT version supporting full functions of E10A.	Normal operation	I_{CC}	—	150	165	mA	$I_0 = 80 \text{ MHz}$ $B_0 = 40 \text{ MHz}$ $P_0 = 40 \text{ MHz}$ $MP_0 = 40 \text{ MHz}$ $MI_0 = 80 \text{ MHz}$	
			—	—	—	—	$MI_0 = 80 \text{ MHz}$	

Item	Page	Revision (See Manual for Details)
24.3.3 AC Bus Timing	917,	Table amended
Table 24.7 Bus Timing	918	

Item	Symbol	Min.	Max.	Unit	Reference Figure
Address delay time 1	t_{AD1}	1	18 (20) ^(*)	ns	Figures 24.11 to 24.15
Address setup time	t_{AS}	0	—	ns	Figures 24.11 to 24.14
Address hold time	t_{AH}	0	—	ns	Figures 24.11 to 24.14
CS delay time	t_{CD}	1	18 (20) ^(*)	ns	Figures 24.11 to 24.15
CS setup time	t_{CS}	0	—	ns	Figures 24.11 to 24.14
CS hold time	t_{CH}	0	—	ns	Figures 24.11 to 24.14
Read strobe delay time	t_{RD}	$1/2t_{BPC} + 1$	$1/2t_{BPC} + 18$ (20) ^(*)	ns	Figures 24.11 to 24.15
Read data setup time 1	t_{RDS1}	$1/2t_{BPC} + 18$ (20) ^(*)	—	ns	Figures 24.11 to 24.15
Read data hold time 1	t_{RDH1}	0	—	ns	Figures 24.11 to 24.15
Read data access time	$t_{RDC}^{n^2}$	$t_{BPC} \times (n + 1.5) - 33^{\text{ns}}$ (35) ^(*)	—	ns	Figures 24.11 to 24.15
Access time from read strobe	$t_{DCE}^{n^2}$	$t_{BPC} \times (n + 1) - 33^{\text{ns}}$ (35) ^(*)	—	ns	Figures 24.11 to 24.15
Write strobe delay time 1	t_{WSD1}	$1/2t_{BPC} + 1$	$1/2t_{BPC} + 18$ (20) ^(*)	ns	Figures 24.11 to 24.15
Write data delay time 1	t_{WDD1}	—	18 (20) ^(*)	ns	Figures 24.11 to 24.15
Write data hold time 1	t_{WDH1}	1	11	ns	Figures 24.11 to 24.15
Write data hold time	t_{WDH}	0	—	ns	Figures 24.11 to 24.14
WAIT setup time	t_{WTS}	$1/2t_{BPC} + 17$ (18) ^(*)	—	ns	Figures 24.12 to 24.15
WAIT hold time	t_{WTH}	$1/2t_{BPC} + 7$ (18) ^(*)	—	ns	Figures 24.12 to 24.15

Note added

Notes:

- Values in parentheses apply to E10A full-function F-ZTAT versions.

24.3.12 AC Characteristics	932	Figure amended
Measurement Conditions		
Figure 24.26 Output Load Circuit		

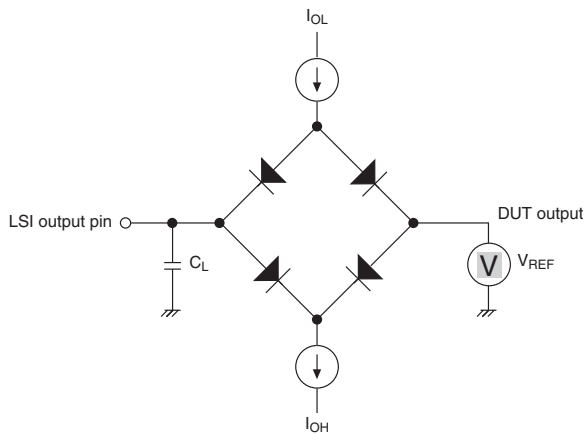

Item	Page	Revision (See Manual for Details)																																																																		
24.5 Flash Memory Characteristics	934	Table amended																																																																		
Table 24.17 Flash Memory Characteristics																																																																				
<table border="1"> <thead> <tr> <th>Item</th> <th>Symbol</th> <th>Min.</th> <th>Typ.</th> <th>Max.</th> <th>Unit</th> </tr> </thead> <tbody> <tr> <td>Programming time^{*)1*)2*)4)}</td> <td>t_p</td> <td>—</td> <td>1</td> <td>20</td> <td>ms/128 bytes</td> </tr> <tr> <td rowspan="3">Erase time^{*)1*)2*)4)}</td> <td rowspan="3">t_e</td> <td>—</td> <td>40</td> <td>260</td> <td>ms/4-Kbyte block</td> </tr> <tr> <td>—</td> <td>300</td> <td>1500</td> <td>ms/32-Kbyte block</td> </tr> <tr> <td>—</td> <td>600</td> <td>3000</td> <td>ms/64-Kbyte block</td> </tr> <tr> <td>Programming time (total)^{*)1*)2*)4)}</td> <td>Σt_p</td> <td>—</td> <td>2.3</td> <td>12</td> <td>s/256 Kbytes</td> </tr> <tr> <td>Erase time (total)^{*)1*)2*)4)}</td> <td>Σt_e</td> <td>—</td> <td>2.3</td> <td>12</td> <td>s/256 Kbytes</td> </tr> <tr> <td>Programming and erase time (total)^{*)1*)2*)4)}</td> <td>Σt_{pe}</td> <td>—</td> <td>4.6</td> <td>24</td> <td>s/256 Kbytes</td> </tr> <tr> <td>Reprogramming count</td> <td>N_{WEC}</td> <td>500^{*)3)}</td> <td>—</td> <td>—</td> <td>Times</td> </tr> </tbody> </table>			Item	Symbol	Min.	Typ.	Max.	Unit	Programming time ^{*)1*)2*)4)}	t_p	—	1	20	ms/128 bytes	Erase time ^{*)1*)2*)4)}	t_e	—	40	260	ms/4-Kbyte block	—	300	1500	ms/32-Kbyte block	—	600	3000	ms/64-Kbyte block	Programming time (total) ^{*)1*)2*)4)}	Σt_p	—	2.3	12	s/256 Kbytes	Erase time (total) ^{*)1*)2*)4)}	Σt_e	—	2.3	12	s/256 Kbytes	Programming and erase time (total) ^{*)1*)2*)4)}	Σt_{pe}	—	4.6	24	s/256 Kbytes	Reprogramming count	N_{WEC}	500 ^{*)3)}	—	—	Times																
Item	Symbol	Min.	Typ.	Max.	Unit																																																															
Programming time ^{*)1*)2*)4)}	t_p	—	1	20	ms/128 bytes																																																															
Erase time ^{*)1*)2*)4)}	t_e	—	40	260	ms/4-Kbyte block																																																															
		—	300	1500	ms/32-Kbyte block																																																															
		—	600	3000	ms/64-Kbyte block																																																															
Programming time (total) ^{*)1*)2*)4)}	Σt_p	—	2.3	12	s/256 Kbytes																																																															
Erase time (total) ^{*)1*)2*)4)}	Σt_e	—	2.3	12	s/256 Kbytes																																																															
Programming and erase time (total) ^{*)1*)2*)4)}	Σt_{pe}	—	4.6	24	s/256 Kbytes																																																															
Reprogramming count	N_{WEC}	500 ^{*)3)}	—	—	Times																																																															
Appendix	943	Newly added																																																																		
B. Processing of Unused Pins																																																																				
D. Product Code Lineup	946	Table amended																																																																		
Table D.1 Product Code Lineup																																																																				
<table border="1"> <thead> <tr> <th rowspan="2">Product Name</th> <th rowspan="2">Classification</th> <th colspan="2">Product Type</th> <th rowspan="2">Application</th> <th rowspan="2">Operating temperature</th> <th rowspan="2">Product Code</th> <th rowspan="2">Package (Package Code)</th> </tr> <tr> <th>ROM Capacity</th> <th>RAM Capacity</th> </tr> </thead> <tbody> <tr> <td rowspan="6">SH7146</td> <td rowspan="2">F-ZTAT version</td> <td rowspan="2">256 kbytes</td> <td rowspan="2">8 kbytes</td> <td>Consumer application</td> <td>-20 to +85 °C</td> <td>R5F71464AN80FPV</td> <td rowspan="2">LQFP1414-80 (FP-80WV)</td> </tr> <tr> <td>Industrial application</td> <td>-40 to +85 °C</td> <td>R5F71464AD80FPV</td> </tr> <tr> <td rowspan="2">Masked ROM version</td> <td rowspan="2">256 kbytes</td> <td rowspan="2">8 kbytes</td> <td>Consumer application</td> <td>-20 to +85 °C</td> <td>R5M71464BNXXXFPV^{*)2)}</td> <td rowspan="2">LQFP1414-100 (FP-100UV)</td> </tr> <tr> <td>Industrial application</td> <td>-40 to +85 °C</td> <td>R5M71464BDXXXFPV^{*)2)}</td> </tr> <tr> <td>F-ZTAT version supporting full functions of E10A^{*)1)}</td> <td>256 kbytes</td> <td>8 kbytes</td> <td>For system development only^{*)1)}</td> <td>0 to +50 °C</td> <td>R5E71464RN80FPV</td> <td></td> </tr> <tr> <td rowspan="6">SH7149</td> <td rowspan="2">F-ZTAT version</td> <td rowspan="2">256 kbytes</td> <td rowspan="2">8 kbytes</td> <td>Consumer application</td> <td>-20 to +85 °C</td> <td>R5F71494AN80FPV</td> <td rowspan="2">LQFP1414-100 (FP-100UV)</td> </tr> <tr> <td>Industrial application</td> <td>-40 to +85 °C</td> <td>R5F71494AD80FPV</td> </tr> <tr> <td rowspan="2">Masked ROM version</td> <td rowspan="2">256 kbytes</td> <td rowspan="2">8 kbytes</td> <td>Consumer application</td> <td>-20 to +85 °C</td> <td>R5M71494BNXXXFPV^{*)2)}</td> <td rowspan="2">LQFP1414-100 (FP-100UV)</td> </tr> <tr> <td>Industrial application</td> <td>-40 to +85 °C</td> <td>R5M71494BDXXXFPV^{*)2)}</td> </tr> <tr> <td>F-ZTAT version supporting full functions of E10A^{*)1)}</td> <td>256 kbytes</td> <td>8 kbytes</td> <td>For system development only^{*)1)}</td> <td>0 to +50 °C</td> <td>R5E71494RN80FPV</td> <td>LQFP1414-100 (FP-100UV)</td> </tr> </tbody> </table>			Product Name	Classification	Product Type		Application	Operating temperature	Product Code	Package (Package Code)	ROM Capacity	RAM Capacity	SH7146	F-ZTAT version	256 kbytes	8 kbytes	Consumer application	-20 to +85 °C	R5F71464AN80FPV	LQFP1414-80 (FP-80WV)	Industrial application	-40 to +85 °C	R5F71464AD80FPV	Masked ROM version	256 kbytes	8 kbytes	Consumer application	-20 to +85 °C	R5M71464BNXXXFPV ^{*)2)}	LQFP1414-100 (FP-100UV)	Industrial application	-40 to +85 °C	R5M71464BDXXXFPV ^{*)2)}	F-ZTAT version supporting full functions of E10A ^{*)1)}	256 kbytes	8 kbytes	For system development only ^{*)1)}	0 to +50 °C	R5E71464RN80FPV		SH7149	F-ZTAT version	256 kbytes	8 kbytes	Consumer application	-20 to +85 °C	R5F71494AN80FPV	LQFP1414-100 (FP-100UV)	Industrial application	-40 to +85 °C	R5F71494AD80FPV	Masked ROM version	256 kbytes	8 kbytes	Consumer application	-20 to +85 °C	R5M71494BNXXXFPV ^{*)2)}	LQFP1414-100 (FP-100UV)	Industrial application	-40 to +85 °C	R5M71494BDXXXFPV ^{*)2)}	F-ZTAT version supporting full functions of E10A ^{*)1)}	256 kbytes	8 kbytes	For system development only ^{*)1)}	0 to +50 °C	R5E71494RN80FPV	LQFP1414-100 (FP-100UV)
Product Name	Classification	Product Type			Application	Operating temperature					Product Code	Package (Package Code)																																																								
		ROM Capacity	RAM Capacity																																																																	
SH7146	F-ZTAT version	256 kbytes	8 kbytes	Consumer application	-20 to +85 °C	R5F71464AN80FPV	LQFP1414-80 (FP-80WV)																																																													
				Industrial application	-40 to +85 °C	R5F71464AD80FPV																																																														
	Masked ROM version	256 kbytes	8 kbytes	Consumer application	-20 to +85 °C	R5M71464BNXXXFPV ^{*)2)}	LQFP1414-100 (FP-100UV)																																																													
				Industrial application	-40 to +85 °C	R5M71464BDXXXFPV ^{*)2)}																																																														
	F-ZTAT version supporting full functions of E10A ^{*)1)}	256 kbytes	8 kbytes	For system development only ^{*)1)}	0 to +50 °C	R5E71464RN80FPV																																																														
	SH7149	F-ZTAT version	256 kbytes	8 kbytes	Consumer application	-20 to +85 °C	R5F71494AN80FPV	LQFP1414-100 (FP-100UV)																																																												
Industrial application					-40 to +85 °C	R5F71494AD80FPV																																																														
Masked ROM version		256 kbytes	8 kbytes	Consumer application	-20 to +85 °C	R5M71494BNXXXFPV ^{*)2)}	LQFP1414-100 (FP-100UV)																																																													
				Industrial application	-40 to +85 °C	R5M71494BDXXXFPV ^{*)2)}																																																														
F-ZTAT version supporting full functions of E10A ^{*)1)}		256 kbytes	8 kbytes	For system development only ^{*)1)}	0 to +50 °C	R5E71494RN80FPV	LQFP1414-100 (FP-100UV)																																																													
E. Package Dimensions		947,	Figures replaced																																																																	
Figure E.1 FP-80WV	948																																																																			
Figure E.2 FP-100UV																																																																				
Figure E.3 FP-100AV	—	Figure deleted																																																																		

Index

A

A/D conversion time.....	619
A/D converter (ADC).....	599
A/D converter activation.....	421
A/D converter characteristics.....	933
A/D converter interrupt source	622
A/D converter start request delaying function.....	404
Absolute accuracy.....	623
Absolute maximum ratings.....	905
AC bus timing.....	917
AC characteristics.....	910
AC characteristics measurement conditions	932
Access in view of LSI internal bus master	230
Access size and data alignment	214
Access wait control.....	220
Address error	79, 88, 844
Address map	199
Addressing modes.....	24
Arithmetic operation instructions	37
Asynchronous mode	533, 566

B

Block transfer mode.....	179
Boot mode.....	772
Branch instructions	41
Break comparison conditions.....	117
Break detection and processing	595
Break on data access cycle.....	142
Break on instruction fetch cycle	141
Bus arbitration	226
Bus clock (B ϕ).....	53
Bus release state.....	45
Bus state controller (BSC).....	197

C

Calculating exception handling vector table addresses	76
Chain transfer.....	180
Changing frequency	67
Clock (MI ϕ) for the MTU2S module	53
Clock (MP ϕ) for the MTU2 module	53
Clock frequency control circuit.....	55
Clock operating mode	58
Clock pulse generator (CPG)	53
Clock synchronous mode	533, 576
Clock timing	911
CMT interrupt sources	635
Compare match timer (CMT)	629
Complementary PWM mode	359
Conflict between NMI interrupt and DTC activation.....	195
Connecting crystal resonator.....	68
Continuous scan mode	616
Control signal timing	914
CPU.....	15
Crystal oscillator	55
CSn assert period extension	222

D

Data transfer controller (DTC).....	153
Data transfer instructions	35
DC characteristics	906
Dead time compensation.....	415
Deep software standby mode	859
Divider	55
DTC activation.....	420
DTC activation by interrupt	191
DTC activation sources.....	166
DTC bus release timing.....	187
DTC execution status	185

DTC vector address 168

E

Error protection 791
Exception handling 73
Exception handling state 45
External clock input method 69
External pulse width measurement 414
External trigger input timing 620

F

Features of instructions 21
Flash memory 735
Flash memory characteristics 934
Flash memory configuration 741
Flash memory emulation in RAM 793
Flow of the user break operation 140
Full-scale error 623
Function for detecting oscillator stop 70

G

General illegal instructions 84
General registers 17
Global-base register (GBR) 18

H

Hardware protection 790

I

I/O ports 709
Illegal slot instructions 84
Immediate data formats 21
Influences on absolute accuracy 626
Initial user branch processing time 800

Initial values of control register 19
Initial values of general register 19
Initial values of system register 19
Initiation intervals of user branch
processing 800
Instruction formats 27
Instruction set 31
Interrupt controller (INTC) 91
Interrupt exception handling
vector table 106
Interrupt priority 82
Interrupt response time 113
Interrupt sequence 109
Interrupts 81
IRQ interrupts 104

L

List of registers 863
Location of transfer information and
DTC vector table 166
Logic operation instructions 39

M

Manual reset 78
Masked ROM 841
MCU extension mode 49
MCU operating modes 47
Module standby mode 860
Module standby mode setting 194, 597, 626,
..... 637, 842, 844
MTU2 functions 238
MTU2 interrupts 419
MTU2 output pin initialization 453
MTU2–MTU2S synchronous operation . 408
MTU2S functions 486
Multi-function timer pulse unit 2
(MTU2) 237

Multi-function timer pulse unit 2S (MTU2S)	485
Multiply and accumulate registers (MACH and MACL)	19
Multiprocessor communication function.....	585

N

NMI interrupt.....	104
Nonlinearity error	623
Normal space interface	216
Normal transfer mode	176
Note on changing operating mode	52
Note on crystal resonator	71
Notes on board design	71, 627
Notes on connecting V_{CL} capacitor	935
Notes on noise countermeasures.....	628
Notes on register access (WDT)	529
Notes on slot illegal instruction exception handling.....	89

O

Offset error	623
On-board programming mode	772
On-chip peripheral module interrupts.....	105
Operating clock for each module.....	56

P

Package dimensions.....	947
PC trace	144
Peripheral clock ($P\phi$)	53
Permissible signal source impedance.....	626
Pin function controller (PFC)	641
Pin states of bus related signals	944
Pin states of this LSI in each processing state.....	937
Port output enable (POE).....	493

Power-down modes.....	845
Power-down state.....	45
Power-on reset	77
Procedure register (PR)	19
Product code lineup.....	946
Program counter (PC)	19
Program execution state	45
Programmer mode.....	840

Q

Quantization error	623
--------------------------	-----

R

RAM	843
Range of analog power supply and other pin settings	627
Register	
ADCR	607
ADCSR	604
ADDR0, ADDR2, ADDR4, ADDR6, and ADDR8 to ADDR15	603
ADTSR	610
BAMRA	121
BAMRB	127
BARA	121
BARB.....	126
BBRA.....	122
BBRB.....	130
BDMRA	125
BDMRB	129
BDRA	124
BDRB.....	128
BETR	137
BRCR.....	132
BRDR.....	139
BRSR	138
BSCEHR.....	165, 210
CMCNT	633

CMCOR.....	633	PACRL1.....	659
CMCSR.....	631	PACRL2.....	659
CMNCR.....	203	PACRL3.....	659
CMSTR.....	631	PACRL4.....	659
CRA.....	160	PADRL.....	712
CRB.....	161	PAIORL.....	659
CS0BCR and CS1BCR.....	205	PAPRL.....	714
CS0WCR and CS1WCR.....	208	PBCRH1.....	674
DAR (DTC).....	159	PBCRL1.....	674
DPFR.....	756	PBCRL2.....	674
DTCCR.....	163	PBDRH.....	716
DTCERA to DTCERE.....	162	PBDRL.....	716
DTCVBR.....	165	PBIORH.....	673
FCCS.....	748	PBIORL.....	673
FEBS.....	767	PBPRH.....	719
FECS.....	751	PBPRL.....	719
FKEY.....	752	PDCRL1.....	681
FMATS.....	753	PDCRL2.....	681
FMPAR.....	762	PDCRL3.....	681
FMPDR.....	763	PDCRL4.....	681
FPCS.....	751	PDDR.....	722
FPEFEQ.....	758	PDIORL.....	681
FPFR.....	761, 764, 768	PDPRL.....	724
FRQCR.....	63	PECRH1.....	689
FTDAR.....	754	PECRH2.....	689
FUBRA.....	759	PECRL1.....	689
ICR0.....	95	PECRL2.....	689
ICSR1.....	498	PECRL3.....	689
ICSR2.....	503	PECRL4.....	689
ICSR3.....	508	PEDRH.....	727
IFCR.....	706	PEDRL.....	727
IPRA, IPRD to IPRF and IPRH to IPRL.....	101	PEIORH.....	688
IRQCR.....	96	PEIORL.....	688
IRQSR.....	98	PEPRH.....	730
MRA.....	156	PEPRL.....	730
MRB.....	157	PFDR.....	733
OCSR1.....	502	POECR1.....	511
OCSR2.....	507	POECR2.....	513
OSCCR.....	66	RAMCR.....	855
		RAMER.....	770

SAR (DTC).....	159
SCBRR (SCI)	553
SCRDR	537
SCRSR (SCI).....	537
SCSCR (SCI).....	541
SCSDCR.....	552
SCSMR (SCI).....	538
SCSPTR (SCI).....	550
SCSSR	544
SCTDR	538
SCTSR (SCI)	537
SPOER.....	510
STBCR1.....	848
STBCR2.....	849
STBCR3.....	850
STBCR4.....	851
STBCR5.....	853
STBCR6.....	854
TADCOBRA_4	296
TADCOBRB_4.....	296
TADCORA_4	296
TADCORB_4	296
TADCR.....	293
TBTER.....	321
TBTM	288
TCBR.....	318
TCDR.....	317
TCNT.....	297
TCNTCMPCLR.....	274
TCNTS.....	316
TCR	248
TCSYSTR.....	302
TDDR	317
TDER.....	323
TGCR.....	314
TGR	297
TICCR	289
TIER	275
TIOR.....	255
TITCNT	320

TITCR.....	318
TMDR.....	252
TOCR1	307
TOCR2.....	310
TOER	306
TOLBR	313
TRWER	305
TSR	280
TSTR.....	298
TSYCR.....	291
TSYR	300
TWCR.....	324
WTCNT	526
WTCSR.....	527

Register address table

(in the order from lower addresses)	864
Register bit list	876
Register data format.....	20
Register states in each operating mode ...	894
Repeat transfer mode	177
Reset state	45
Reset-synchronized PWM mode.....	356
RISC-type	21

S

SCI interrupt sources.....	591
SCSPTR and SCI pins	592
Sending a break signal	595
Sequential break.....	143
Serial communication interface (SCI).....	533
Shift instructions	40
Single chip mode.....	49
Single mode	616
Single-cycle scan mode.....	617
Sleep mode.....	856
Software protection	791
Software standby mode.....	857
Stack after interrupt exception handling	112

Stack states after exception handling ends.....	86
Status register (SR).....	17
System control instructions.....	42

T

Target pins and conditions for high-impedance control.....	516
The address map for the operating modes.....	50
Transfer information read skip function.....	175
Transfer information writeback skip function.....	176
Trap instructions.....	83

U

User boot mode.....	785
---------------------	-----

User break controller (UBC).....	117
User break interrupt.....	105
User MAT.....	742
User program mode.....	776
Using interval timer mode.....	531
Using watchdog timer mode.....	530

V

Vector numbers and vector table address offsets.....	75
Vector-base register (VBR).....	18

W

Wait between access cycles.....	223
Watchdog timer (WDT).....	523

Renesas 32-Bit RISC Microcomputer
SH7146 Group
User's Manual: Hardware

Publication Date: Rev.1.00, April 1, 2005
Rev.4.00, September 24, 2010

Published by: Renesas Electronics Corporation

**SALES OFFICES**

Renesas Electronics Corporation

<http://www.renesas.com>

Refer to "http://www.renesas.com" for the latest and detailed information.

Renesas Electronics America Inc.
2880 Scott Boulevard Santa Clara, CA 95050-2554, U.S.A.
Tel: +1-408-588-6000, Fax: +1-408-588-6130

Renesas Electronics Canada Limited
1101 Nicholson Road, Newmarket, Ontario L3Y 9C3, Canada
Tel: +1-905-898-5441, Fax: +1-905-898-3220

Renesas Electronics Europe Limited
Dukes Meadow, Millboard Road, Bourne End, Buckinghamshire, SL8 5FH, U.K.
Tel: +44-1628-585-100, Fax: +44-1628-585-900

Renesas Electronics Europe GmbH
Arcadiastrasse 10, 40472 Düsseldorf, Germany
Tel: +49-211-65030, Fax: +49-211-6503-1327

Renesas Electronics (China) Co., Ltd.
7th Floor, Quantum Plaza, No.27 ZhiChunLu Haidian District, Beijing 100083, P.R.China
Tel: +86-10-8235-1155, Fax: +86-10-8235-7679

Renesas Electronics (Shanghai) Co., Ltd.
Unit 204, 205, AZIA Center, No.1233 Lujiazui Ring Rd., Pudong District, Shanghai 200120, China
Tel: +86-21-5877-1818, Fax: +86-21-6887-7858 / -7898

Renesas Electronics Hong Kong Limited
Unit 1601-1613, 16/F., Tower 2, Grand Century Place, 193 Prince Edward Road West, Mongkok, Kowloon, Hong Kong
Tel: +852-2886-9318, Fax: +852-2886-9022/9044

Renesas Electronics Taiwan Co., Ltd.
7F, No. 363 Fu Shing North Road Taipei, Taiwan
Tel: +886-2-8175-9600, Fax: +886-2-8175-9670

Renesas Electronics Singapore Pte. Ltd.
1 HarbourFront Avenue, #06-10, Keppel Bay Tower, Singapore 098632
Tel: +65-6213-0200, Fax: +65-6278-8001

Renesas Electronics Malaysia Sdn.Bhd.
Unit 906, Block B, Menara Amcorp, Amcorp Trade Centre, No. 18, Jln Persiaran Barat, 46050 Petaling Jaya, Selangor Darul Ehsan, Malaysia
Tel: +60-3-7955-9390, Fax: +60-3-7955-9510

Renesas Electronics Korea Co., Ltd.
11F., Samik Laviel' or Bldg., 720-2 Yeoksam-Dong, Kangnam-Ku, Seoul 135-080, Korea
Tel: +82-2-558-3737, Fax: +82-2-558-5141



SH7146 Group
User's Manual: Hardware

X-ON Electronics

Largest Supplier of Electrical and Electronic Components

Click to view similar products for [8-bit Microcontrollers - MCU category](#):

Click to view products by [Renesas manufacturer](#):

Other Similar products are found below :

[CY8C20524-12PVXIT](#) [CY8C28433-24PVXIT](#) [MB95F012KPFT-G-SNE2](#) [MB95F013KPMC-G-SNE2](#) [MB95F263KPF-G-SNE2](#)
[MB95F264KPFT-G-SNE2](#) [MB95F398KPMC-G-SNE2](#) [MB95F478KPMC2-G-SNE2](#) [MB95F562KPF-G-SNE2](#) [MB95F564KPF-G-SNE2](#)
[MB95F634KPMC-G-SNE2](#) [MB95F636KWQN-G-SNE1](#) [MB95F696KPMC-G-SNE2](#) [MB95F698KPMC1-G-SNE2](#) [MB95F698KPMC2-G-SNE2](#) [MB95F698KPMC-G-SNE2](#) [MB95F818KPMC1-G-SNE2](#) [MC908JK1ECDWER](#) [MC9S08PA32AVLD](#) [MC9S08PT60AVLD](#)
[R5F1076CMSPV0](#) [R5F5631ECDFBV0](#) [C8051F389-B-GQ](#) [C8051F392-A-GMR](#) [ISD-ES1600_USB_PROG](#) [901015X](#) [SC705C8AE0VFBE](#)
[STM8TL53G4U6](#) [PIC16F877-04/P-B](#) [R5F10Y17ASP#30](#) [CY8C3MFIDOCK-125](#) [403708R](#) [MB95F354EPF-G-SNE2](#) [MB95F564KPFT-G-SNE2](#) [MB95F564KWQN-G-SNE1](#) [MB95F636KP-G-SH-SNE2](#) [MB95F636KPMC-G-SNE2](#) [MB95F694KPMC-G-SNE2](#) [MB95F778JPMC1-G-SNE2](#) [MB95F818KPMC-G-SNE2](#) [MC908QY8CDWER](#) [MC9S08PT16AVLD](#) [MC9S08PT32AVLH](#) [MC9S08PT60AVLC](#)
[MC9S08PT60AVLH](#) [C8051F500-IQR](#) [LC87F0G08AUJA-AH](#) [CP8361BT](#) [STM8S207C6T3](#) [CG8421AF](#)