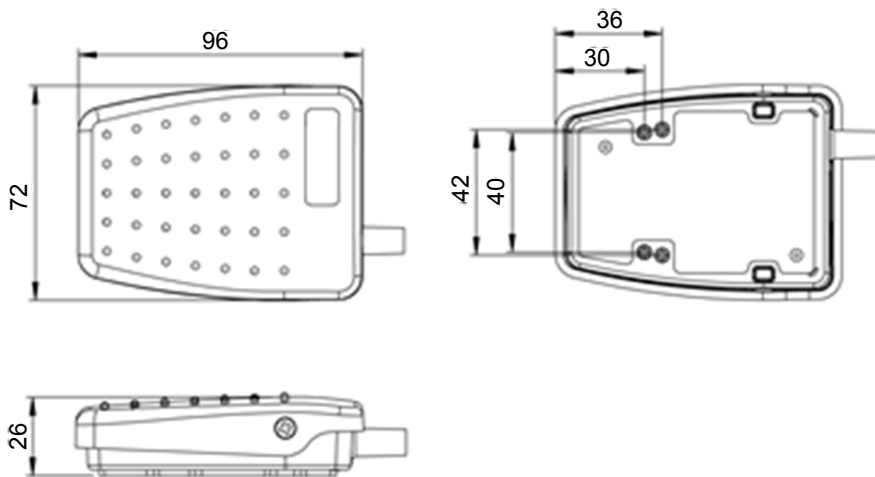

**Cost effective range - ex stock delivery**

- Low profile, rear hinged switch designed for improved user comfort
- All plastic construction with raised tread pattern and anti-slip pad
- Versatile and innovative design make it an ideal product for OEM use

**Reference dimensions****6227-SC General specifications**

<b>Standards/approvals</b>	Footswitch: low voltage directive 2014/35/EU, EN 60950
<b>Degree of protection</b>	EN 60529 IPX2
<b>Connection method</b>	2m of black cable with stripped ends
<b>Electrical rating</b>	6A 250V AC
<b>Contact configuration</b>	SPST N/O (Single pole normally open), Momentary action
<b>Operating temperature range</b>	-20°C to +60°C
<b>Body material</b>	Thermoplastic
<b>Weight</b>	0.12Kg
<b>Additional information</b>	Black cover, black base

Minimum delivered batch quantities - 100 pcs

## **X-ON Electronics**

Largest Supplier of Electrical and Electronic Components

*Click to view similar products for [herga manufacturer](#):*

Other Similar products are found below :

[6433-0019](#) [6289-PP](#) [6254-OB](#) [6442-OW](#) [6438-ACAC-AB00](#) [6227-0004](#) [6289-01](#) [6251-BAAA-CBZ0](#) [6226-0003](#) [6438-ABAB-AB00](#) [6289-CC](#) [6753-AEJA-A000](#) [6448-AAAB-0000](#) [6871-0C](#)