

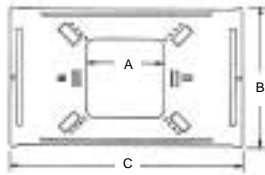

# TILE BRIDGES FOR 4" AND 8" LOUDSPEAKERS

81-8S  
81-4  
81-8R

THREE

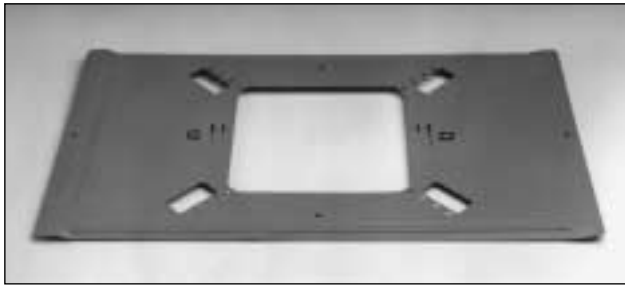

81-8S

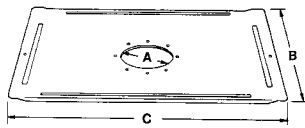
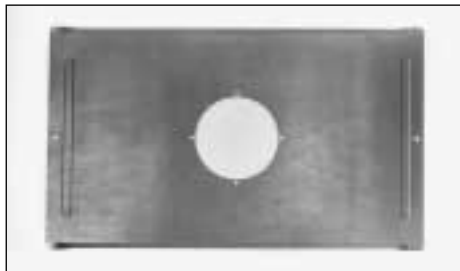

81-4

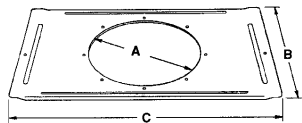
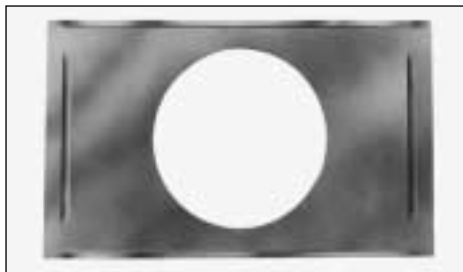

81-8R

## FEATURES

- Locating Tabs Secure the Enclosure to Tile Bridge 81-8S for Easy In-Ceiling Installation of Speakers and Grilles
- Load-Bearing Bridges Eliminate Ceiling Tile Sag by Distributing Assembly Weight to Ceiling's Support System
- Choice of Three Models that Accept a Wide Variety of Baffles and Baffle-Enclosure Combinations
- Rust-Resistant 24-Gauge Electrogalvanized Steel Construction Ensures Long Service Life

## APPLICATIONS

Utilize Atlas Sound 81 Series tile bridges to prevent ceiling tile sag in suspended ceiling installations of loudspeaker assemblies. The 81-8S and 81-8R (accepting 8" loudspeakers) and the 81-4 (designed for 4" loudspeakers) distribute the assembly weight to overhead T-Bar support members.

## GENERAL DESCRIPTION

The 81 Series includes three models and can accommodate over 30 Atlas Sound baffles. The 81-8S is designed to mount 8" loudspeakers and has a square cut-out with a multi-position hole pattern to accommodate an extensive variety of round and square baffles including torsion spring and screw mount models. (See chart below for specific baffle model numbers.) Adaptability of the 81-8S also makes it ideal as a stocking item. Model 81-4 features a round cut-out and accepts 4" loudspeaker baffle Models 51-4 and 60-4. Model 81-8R, like the 81-8S, handles 8" loudspeakers but features a round cut-out that suits baffles mounting the industry standard Atlas Sound 95 Series enclosures. All tile bridges are constructed of 24-gauge CRS with an electrogalvanized rust-resistant finish.

MODEL	DIMENSIONS			WEIGHT
	A	B	C	
81-8S	8" (203mm)	14 1/4" (359mm)	23 3/8" (600mm)	2.0 lbs. (.9 kg.)
81-4	5 5/16" (132mm)			2.6 lbs. (1.2 kg.)
81-8R	10 3/4" (273mm)			2.0 lbs. (.9 kg.)

MOUNTS BAFFLE MODELS	
81-8S	51-8, T51-8, 60-8(W), T60-8(W), 61-8W, T61-8W, (T)62-8, 63-8, 67-8(W), 68-8W, 161-8, T161-8, 164-8, T164-8, 169-8, 170-8, M222(W), TM222W, T620-8, T610-8W, T710-8, T720-8A, P900, P910, P912
81-4	51-4, 60-4 (Grilles Only)
81-8R	51-8, 60-8(W), 61-8W, 62-8, 63-8, 67-8(W), 68-8W, 170-8, M222(W), P900

## ARCHITECT AND ENGINEER SPECIFICATIONS

The items described are installation accessories, and their use is determined by the baffle, enclosure, or loudspeaker package series selected. Refer to the Architect and engineer Specifications outlined on each component specification sheet.

Specifications subject to change without notice



1601 JACK MCKAY BLVD. / ENNIS, TEXAS 75119 U.S.A. / TELEPHONE: (800) 876-3333 / FAX (800) 765-3435

## INSTALLATION

### Easy installation of the 81 Series is accomplished by:

1. Cutting a hole in the ceiling tile and placing a tile bridge over the hole from above. The top of the enclosure (not the rim) may be used as a pattern for proper hole dimension.
2. Mount the enclosure from above.
3. Mount the loudspeaker/baffle assembly through the ceiling tile and tile bridge to the enclosure. (See illustrations below.) For applications where enclosures are not required, installation is the same—except loudspeaker and baffle mount to tile bridge using J-Nuts.

### Additional information:

- Install mounting screws through grille mounting holes into tile bridge or enclosure
- J-Nuts can be relocated to accommodate specific backbox or grille models
- Adjustments may need to be made when installing a torsion spring grille, T-bar, and an enclosure. See Special Application below
- Floor-side backbox installation is possible with Model 81-8R only using J-Nuts.

### TYPICAL ASSEMBLY OF 81-8S TILE BRIDGE

Mounting the tile bridge with flanges facing up offers the the most strength.

To prevent metal-to-metal rattle, install four HX76 felt tabs (order separately)

Square Cut-Out (with multi-position hole pattern to accept various enclosures).

Ceiling Tile (5/8" min. thickness when using torsion slots)

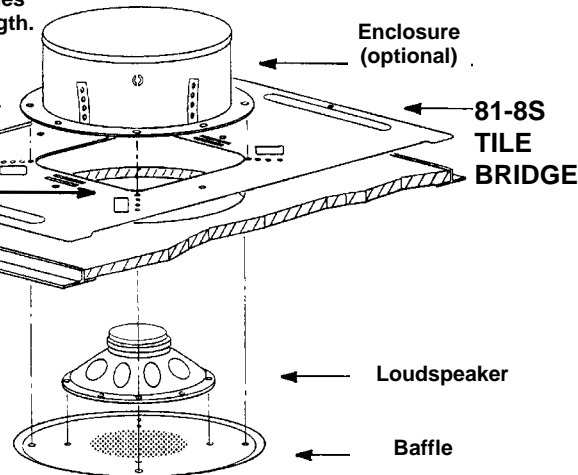

### NEW

Use enclosure tabs for temporary positioning of enclosures during pre-installation.

1. Locate and bend up the two positioning tabs.
2. Place the enclosure on top of the tabs
3. Bend tabs down to temporarily hold enclosure. Speaker mounting holes on enclosure and bridge should be in alignment and ready for future loudspeaker/baffle mounting.

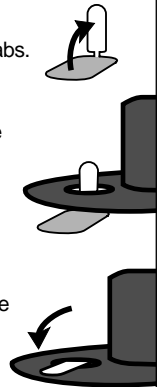

**Special Application for 81-8S:** When a torsion spring grille, tile bridge, and enclosure are specified, the grille will mount to the tile bridge only and not to the enclosure's torsion tabs. The enclosure

will need to be secured to the tile bridge via four 8-32 screws (not included). [In some cases, the enclosure may need to be rotated to avoid the torsion tabs and insure a proper fit.]

### TYPICAL ASSEMBLY OF 81-8R TILE BRIDGE

Mounting holes are 1 1/4" (286mm) center to center (4 are tapped holes, 4 are clearance holes).

Round Loudspeaker Clearance Hole (Cut 1 1/2" (292mm) hole in ceiling tile for 95 Series and other typical enclosures.)

**Note:** Floor-side installation is possible by pushing enclosure through clearance hole and securing lip of enclosure to ceiling tile and tile bridge.

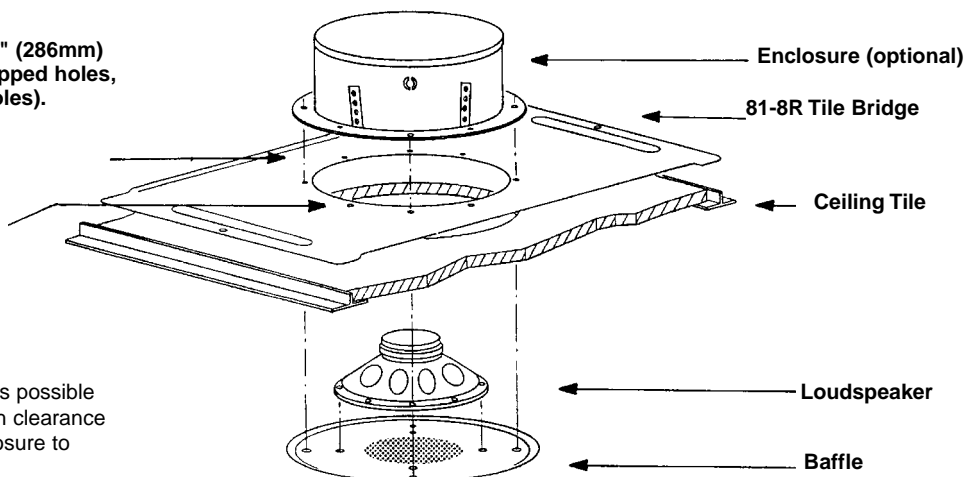

**Note:** The 81-8R does not include slots for mounting torsion spring grilles.

Specifications subject to change without notice



1601 JACK MCKAY BLVD. / ENNIS, TEXAS 75119 U.S.A. / TELEPHONE: (800) 876-3333 / FAX (800) 765-3435

## **X-ON Electronics**

Largest Supplier of Electrical and Electronic Components

*Click to view similar products for [atlas sound manufacturer](#):*

Other Similar products are found below :

[SD72](#) [AAGRMK2](#)