

Ball End Socket Bits

- ProGuard™ Finish -

- Bits fit any standard six point socket
- Ball End inserts into a screw at a 25° angle
- Ball End saves time by quickly funneling tool into screw
- Superior Ball End strength and working angle

ProGuard™ finish delivers superior corrosion protection

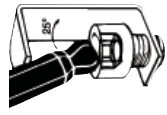

Ball End Tips



Molded Black Case

Clamshell Package

SETS	PART#	MODEL#	PCS	BIT LENGTH	DESCRIPTION	PACKED IN	CONTENTS	QTY	LIST
Inch	43445	PHB7/S-2	7	2"/50mm	Sockets & Bits	Transparent Clamshell	1/8, 5/32, 3/16, 7/32, 1/4, 5/16, 3/8"	1	
	43845	PHB7/S-6	7	6"/150mm	Sockets & Bits	Transparent Clamshell	1/8, 5/32, 3/16, 7/32, 1/4, 5/16, 3/8"	1	
	31445	PHB7-2	7	2"/50mm	Bits Only	Transparent Clamshell	1/8, 5/32, 3/16, 7/32, 1/4, 5/16, 3/8"	1	
	31645	PHB7-6	7	6"/150mm	Bits Only	Transparent Clamshell	1/8, 5/32, 3/16, 7/32, 1/4, 5/16, 3/8"	1	
	30445	PHB7/S-2C	7	2"/50mm	Sockets & Bits	Molded Black Case	1/8, 5/32, 3/16, 7/32, 1/4, 5/16, 3/8"	1	
	30845	PHB7/S-6C	7	6"/150mm	Sockets & Bits	Molded Black Case	1/8, 5/32, 3/16, 7/32, 1/4, 5/16, 3/8"	1	
23445	PHB7-2C	7	2"/50mm	Bits Only	Molded Black Case	1/8, 5/32, 3/16, 7/32, 1/4, 5/16, 3/8"	1		
Metric	43487	PHB8M/S-2	8	2"/50mm	Sockets & Bits	Transparent Clamshell	3, 4, 5, 6, 7, 8, 9, 10mm	1	
	43887	PHB8M/S-6	8	6"/150mm	Sockets & Bits	Transparent Clamshell	3, 4, 5, 6, 7, 8, 9, 10mm	1	
	31487	PHB8M-2	8	2"/50mm	Bits Only	Transparent Clamshell	3, 4, 5, 6, 7, 8, 9, 10mm	1	
	31687	PHB8M-6	8	6"/150mm	Bits Only	Transparent Clamshell	3, 4, 5, 6, 7, 8, 9, 10mm	1	
	30487	PHB8M/S-2C	8	2"/50mm	Sockets & Bits	Molded Black Case	3, 4, 5, 6, 7, 8, 9, 10mm	1	
	30887	PHB8M/S-6C	8	6"/150mm	Sockets & Bits	Molded Black Case	3, 4, 5, 6, 7, 8, 9, 10mm	1	
	23487	PHB8M-2C	8	2"/50mm	Bits Only	Molded Black Case	3, 4, 5, 6, 7, 8, 9, 10mm	1	



BIT ONLY



SOCKET AND BIT



BIT ONLY



SOCKET AND BIT

SINGLES		SIZE	PART#	QTY	LISTEA	DRIVE	QTY	LISTEA	
Inch	2" Long	50mm Long	1/8	31407	1	3/8"			
			5/32	31409	1	3/8"			
			3/16	31410	1	3/8"			
			7/32	31411	1	3/8"			
			1/4	31412	1	3/8"			
			5/16	31413	1	3/8"			
			3/8	31414	1	3/8"			
	5/16	-	-	43913	1	1/2"			
	3/8	-	-	43914	1	1/2"			
	1/2	31416	1	43916	1	1/2"			
	9/16	31417	1	43917	1	1/2"			
	5/8	31418	1	43918	1	1/2"			
	3/4	31419	1	43919	1	1/2"			
	Inch	6" Long	150mm Long	1/8	31607	1	3/8"		
5/32				31609	1	3/8"			
3/16				31610	1	3/8"			
7/32				31611	1	3/8"			
1/4				31612	1	3/8"			
5/16				31613	1	3/8"			
3/8				31614	1	3/8"			
1/2		31616	1	43716	1	1/2"			
9/16		31617	1	43717	1	1/2"			
5/8		31618	1	43718	1	1/2"			
3/4		31619	1	43719	1	1/2"			
Metric		2" Long	50mm Long	3.0	31456	1	3/8"		
				4.0	31460	1	3/8"		
				5.0	31464	1	3/8"		
	6			31468	1	3/8"			
	7			31470	1	3/8"			
	8			31472	1	3/8"			
	9			31474	1	3/8"			
	10	31476	1	3/8"					
	12	31480	1	3/8"					
	12	-	-	43980	1	1/2"			
	14	31484	1	43984	1	1/2"			
	17	31486	1	43986	1	1/2"			
	19	31488	1	43988	1	1/2"			
	Metric	6" Long	150mm Long	3.0	31656	1	3/8"		
4.0				31660	1	3/8"			
5.0				31664	1	3/8"			
6				31668	1	3/8"			
7				31670	1	3/8"			
8				31672	1	3/8"			
9				31674	1	3/8"			
10		31676	1	43876	1	3/8"			
12		31680	1	43780	1	1/2"			
14		31684	1	43784	1	1/2"			
17		31686	1	43786	1	1/2"			
19		31688	1	43788	1	1/2"			

Distributed by:

Bondhus Corporation
1400 E Broadway • PO Box 660 • Monticello, MN 55362
Tel: 763-295-2162 • Toll Free: 800-328-8310 • Fax: 763-295-4440

TORX® and TORX PLUS® are registered trademarks of Acument Intellectual Properties, LLC.

Bondhus, Protanium and ProGuard are trademarks of Bondhus Corporation.

EDP# 97393.99

©2014 Bondhus Corporation.

BONDHUS®

TOOLS THAT WORK

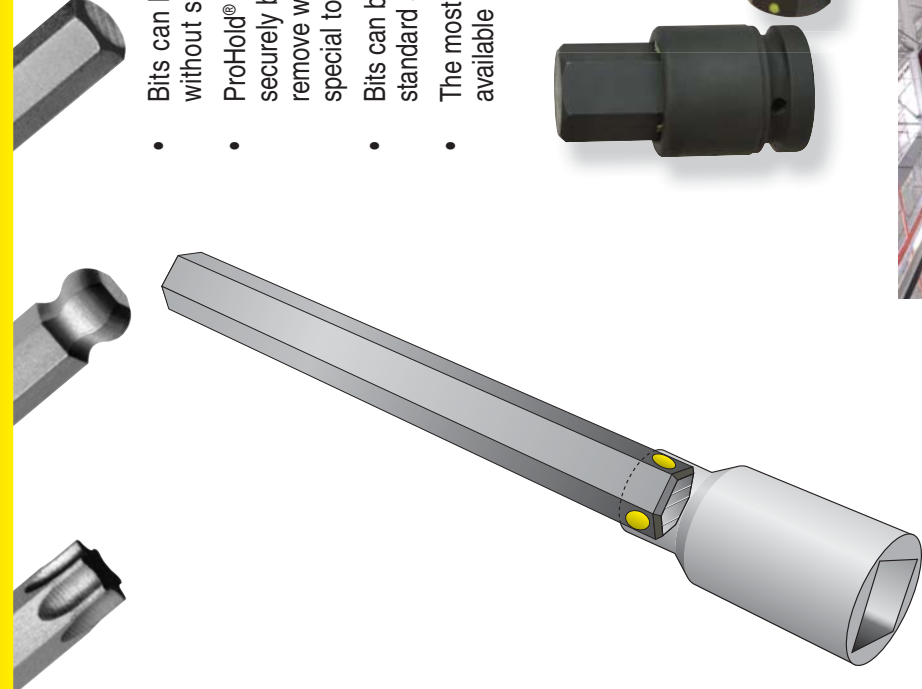

- Bits can be purchased with or without sockets
- ProHold® technology holds bits securely but remains easy to remove without the use of special tools
- Bits can be used with any standard six point socket
- The most economical solution available



BONDHUS
LIFETIME WARRANTY
If any Bondhus® tool breaks or fails to meet your expectations in any way, we will replace it free of charge.

ProJenium
HIGH TORQUE STEEL

High Torque Steel:

Up to 20% stronger, with more torque and twice the wear resistance of standard grades of steel.

FINISH OPTIONS:



Corrosion-resistant finish:

Environmentally safe, provides better tool grip, resists solvents and is 5 times more corrosion resistant than competitor finishes.

ProHold® Socket Bit Technology



Bondhus ProHold® technology is a revolution in holding systems that makes all other holding systems obsolete. Bits seat firmly into socket. No special tools are required to remove bits from sockets.



BONDHUS 1/4 USA

Bit sizes are clearly printed in white ink.



ProHold® buttons hold bit securely while allowing easy removal without the use of set screws or roll pins.



Bits are suitable for use with standard or impact sockets.

www.bondhus.com

Hex End Socket Bits

- Bits fit any standard six point socket
- Bits are suitable for use with impact sockets
- Chamfered tool tips eliminate burrs and help tools seat in screw head
- Sharp corners transfer more torque to the screw and reduce stripping
- Precision machined for ease of use and superior fit



Hex End Tips

Molded Black Case

Clamshell Package

Sets		PART#	MODEL#	PCS	BIT LENGTH	DESCRIPTION	PACKED IN	CONTENTS	QTY	LIST
Inch	43299	PHX9/S-2	9	2 1/2	50mm	Sockets & Bits	Transparent Clamshell	5/32, 3/16, 7/32, 1/4, 5/16, 3/8, 1/2, 9/16, 5/8"	1	
	43645	PHX5/S-6	5	6 1/2	150mm	Sockets & Bits	Transparent Clamshell	5/16, 3/8, 1/2, 9/16, 5/8"	1	
	33299	PHX9-2	9	2 1/2	50mm	Bits Only	Transparent Clamshell	5/32, 3/16, 7/32, 1/4, 5/16, 3/8, 1/2, 9/16, 5/8"	1	
	33645	PHX5-6	5	6 1/2	150mm	Bits Only	Transparent Clamshell	5/16, 3/8, 1/2, 9/16, 5/8"	1	
	30299	PHX9/S-2C	9	2 1/2	50mm	Sockets & Bits	Molded Black Case	5/32, 3/16, 7/32, 1/4, 5/16, 3/8, 1/2, 9/16, 5/8"	1	
	30645	PHX5/S-6C	5	6 1/2	150mm	Sockets & Bits	Molded Black Case	5/32, 3/16, 7/32, 1/4, 5/16, 3/8, 1/2, 9/16, 5/8"	1	
	23299	PHX9-2C	9	2 1/2	50mm	Bits Only	Molded Black Case	5/32, 3/16, 7/32, 1/4, 5/16, 3/8, 1/2, 9/16, 5/8"	1	
	43298	PHX9M/S-2	9	2 1/2	50mm	Sockets & Bits	Transparent Clamshell	4, 5, 6, 7, 8, 10, 12, 14, 17mm	1	
	43646	PHX6M/S-6	6	6 1/2	150mm	Sockets & Bits	Transparent Clamshell	4, 5, 6, 7, 8, 10mm	1	
	33298	PHX9M-2	9	2 1/2	50mm	Bits Only	Transparent Clamshell	4, 5, 6, 7, 8, 10, 12, 14, 17mm	1	
33646	PHX6M-6	6	6 1/2	150mm	Bits Only	Transparent Clamshell	4, 5, 6, 7, 8, 10mm	1		
30298	PHX9M/S-2C	9	2 1/2	50mm	Sockets & Bits	Molded Black Case	4, 5, 6, 7, 8, 10, 12, 14, 17mm	1		
30646	PHX6M/S-6C	6	6 1/2	150mm	Sockets & Bits	Molded Black Case	4, 5, 6, 7, 8, 10mm	1		
23246	PHX6M-2C	6	2 1/2	50mm	Bits Only	Molded Black Case	4, 5, 6, 7, 8, 10mm	1		
23298	PHX9M-2C	9	2 1/2	50mm	Bits Only	Molded Black Case	4, 5, 6, 7, 8, 10, 12, 14, 17mm	1		
23296	PHX9ML-2C	9	2 1/2	50mm	Bits Only	Molded Black Case	5, 6, 7, 8, 10, 12, 14, 17, 19mm	1		



BIT ONLY

SOCKET AND BIT



BIT ONLY

SOCKET AND BIT

Singles		SIZE	PART#	QTY	LIST EA	PART#	QTY	DRIVE	LIST EA
Inch	2" Long	1/8	33207	1	3/8"	43207	1	3/8"	
		5/32	33209	1	3/8"	43209	1	3/8"	
		3/16	33210	1	3/8"	43210	1	3/8"	
		7/32	33211	1	3/8"	43211	1	3/8"	
		1/4	33212	1	3/8"	43212	1	3/8"	
		5/16	33213	1	3/8"	43213	1	3/8"	
	2.5" Long	3/8	33214	1	3/8"	43214	1	3/8"	
		1/2	33216	1	1/2"	43216	1	1/2"	
		9/16	33217	1	1/2"	43217	1	1/2"	
		5/8	33218	1	1/2"	43218	1	1/2"	
		3/4	33219	1	1/2"	43219	1	1/2"	
		7/8	33220	1	1/2"	43220	1	1/2"	
Inch	2.5" Long	1	33221	1	1/2"	43221	1	1/2"	
		1 1/8	33223	1	1/2"	43223	1	1/2"	
		1 1/4	33225	1	1/2"	43225	1	1/2"	
		1 1/2	33229	1	1/2"	43229	1	1/2"	
		1 3/4	33231	1	1/2"	43231	1	1/2"	
		2	33233	1	1/2"	43233	1	1/2"	
	6" Long	1/8	33607	1	3/8"	43507	1	3/8"	
		5/32	33609	1	3/8"	43509	1	3/8"	
		3/16	33610	1	3/8"	43510	1	3/8"	
		7/32	33611	1	3/8"	43511	1	3/8"	
		1/4	33612	1	3/8"	43512	1	3/8"	
		5/16	33613	1	3/8"	43513	1	3/8"	
6" Long	3/8	33614	1	3/8"	43514	1	3/8"		
	5/16	-	-	1/2"	43613	1	1/2"		
	3/8	-	-	1/2"	43614	1	1/2"		
	1/2	33616	1	1/2"	43616	1	1/2"		
	9/16	33617	1	1/2"	43617	1	1/2"		
	5/8	33618	1	1/2"	43618	1	1/2"		
3/4	33619	1	1/2"	43619	1	1/2"			



BIT ONLY

SOCKET AND BIT

Singles		SIZE	PART#	QTY	LIST EA	PART#	QTY	DRIVE	LIST EA	
Metric	2" Long	3.0	33256	1	3/8"	43256	1	3/8"		
		4.0	33260	1	3/8"	43260	1	3/8"		
		5.0	33264	1	3/8"	43264	1	3/8"		
		6	33268	1	3/8"	43268	1	3/8"		
		7	33270	1	3/8"	43270	1	3/8"		
		8	33272	1	3/8"	43272	1	3/8"		
		9	33274	1	3/8"	43274	1	3/8"		
		10	33276	1	3/8"	43276	1	3/8"		
		12	33280	1	1/2"	43280	1	1/2"		
	2.5" Long	14	33284	1	1/2"	43284	1	1/2"		
		17	33286	1	1/2"	43286	1	1/2"		
		19	33288	1	1/2"	43288	1	1/2"		
		22	33291	1	-	-	-	-		
		24	33293	1	-	-	-	-		
		27	33295	1	-	-	-	-		
		32	33297	1	-	-	-	-		
		36	33200	1	-	-	-	-		
		Metric	6" Long	3.0	33656	1	3/8"	43656	1	3/8"
	4.0			33660	1	3/8"	43660	1	3/8"	
5.0	33664			1	3/8"	43664	1	3/8"		
6	33668			1	3/8"	43668	1	3/8"		
7	33670			1	3/8"	43670	1	3/8"		
8	33672			1	3/8"	43672	1	3/8"		
9	33674			1	3/8"	43674	1	3/8"		
10	33676			1	3/8"	43676	1	3/8"		
12	33680			1	1/2"	43680	1	1/2"		
Metric	6" Long	14	33684	1	1/2"	43684	1	1/2"		
		17	33686	1	1/2"	43686	1	1/2"		
		19	33688	1	1/2"	43688	1	1/2"		



BIT ONLY

SOCKET AND BIT

Singles		SIZE	PART#	QTY	LIST EA	PART#	QTY	DRIVE	LIST EA
Inch	2" Long	1/8	33207	1	3/8"	43207	1	3/8"	
		5/32	33209	1	3/8"	43209	1	3/8"	
		3/16	33210	1	3/8"	43210	1	3/8"	
		7/32	33211	1	3/8"	43211	1	3/8"	
		1/4	33212	1	3/8"	43212	1	3/8"	
		5/16	33213	1	3/8"	43213	1	3/8"	
	2.5" Long	3/8	33214	1	3/8"	43214	1	3/8"	
		1/2	33216	1	1/2"	43216	1	1/2"	
		9/16	33217	1	1/2"	43217	1	1/2"	
		5/8	33218	1	1/2"	43218	1	1/2"	
		3/4	33219	1	1/2"	43219	1	1/2"	
		7/8	33220	1	1/2"	43220	1	1/2"	
Inch	2.5" Long	1	33221	1	1/2"	43221	1	1/2"	
		1 1/8	33223	1	1/2"	43223	1	1/2"	
		1 1/4	33225	1	1/2"	43225	1	1/2"	
		1 1/2	33229	1	1/2"	43229	1	1/2"	
		1 3/4	33231	1	1/2"	43231	1	1/2"	
		2	33233	1	1/2"	43233	1	1/2"	
	6" Long	1/8	33607	1	3/8"	43507	1	3/8"	
		5/32	33609	1	3/8"	43509	1	3/8"	
		3/16	33610	1	3/8"	43510	1	3/8"	
		7/32	33611	1	3/8"	43511	1	3/8"	
		1/4	33612	1	3/8"	43512	1	3/8"	
		5/16	33613	1	3/8"	43513	1	3/8"	
6" Long	3/8	33614	1	3/8"	43514	1	3/8"		
	5/16	-	-	1/2"	43613	1	1/2"		
	3/8	-	-	1/2"	43614	1	1/2"		
	1/2	33616	1	1/2"	43616	1	1/2"		
	9/16	33617	1	1/2"	43617	1	1/2"		
	5/8	33618	1	1/2"	43618	1	1/2"		
3/4	33619	1	1/2"	43619	1	1/2"			

TORX® Socket Bits

- Fits all TORX® and Star screws
- Bits fit any standard six point socket
- Bits are suitable for use with impact sockets
- Chamfered tool tips eliminate burrs and help tools seat in screw head
- Sharp corners transfer more torque to the screw and reduce stripping
- Precision machined for ease of use and superior fit



TORX®

Molded Black Case

Clamshell Package

Sets		PART#	MODEL#	PCS	BIT LENGTH	DESCRIPTION	PACKED IN	CONTENTS	QTY	LIST
TORX®	44038	PHTX10/S-2	10	2 1/2	50mm	Sockets & Bits	Transparent Clamshell	T10, T15, T20, T25, T27, T30, T40, T45, T50, T55	1	
	44037	PHTX13/S-2	13	2 1/2	50mm	Sockets & Bits	Transparent Clamshell	T8, T10, T15, T20, T25, T27, T30, T40, T45, T47, T50, T55, T60	1	
	44699	PHTX9/S-6	9	6 1/2	150mm	Sockets & Bits	Transparent Clamshell	T8, T9, T10, T15, T20, T25, T27, T30, T40	1	
	44632	PHTX8/S-6	8	6 1/2	150mm	Sockets & Bits	Transparent Clamshell	T8, T10, T15, T20, T25, T27, T30, T40	1	
	32038	PHTX10-2	10	2 1/2	50mm	Bits Only	Transparent Clamshell	T10, T15, T20, T25, T27, T30, T40, T45, T50, T55	1	
	32037	PHTX13-2	13	2 1/2	50mm	Bits Only	Transparent Clamshell	T8, T10, T15, T20, T25, T27, T30, T40, T45, T47, T50, T55, T60	1	
	34099	PHTX9-6	9	6 1/2	150mm	Bits Only	Transparent Clamshell	T8, T9, T10, T15, T20, T25, T27, T30, T40	1	
	34032	PHTX8-6	8	6 1/2	150mm	Bits Only	Transparent Clamshell	T8, T10, T15, T20, T25, T27, T30, T40	1	
	31038	PHTX10/S-2C	10	2 1/2	50mm	Sockets & Bits	Molded Black Case	T10, T15, T20, T25, T27, T30, T40, T45, T50, T55	1	
	30799	PHTX9/S-6C	9	6 1/2	150mm	Sockets & Bits	Molded Black Case	T8, T9, T10, T15, T20, T25, T27, T30, T40	1	

X-ON Electronics

Largest Supplier of Electrical and Electronic Components

Click to view similar products for [bondhus](#) manufacturer:

Other Similar products are found below :

[0456](#) [16538](#) [16537](#) [15364](#) [10699 \(BSX9MM\)](#) [10938 \(BLX10\)](#) [12550](#) [10637 \(BSX13\)](#) [14132](#) [13190](#) [10932 \(BLX8\)](#) [20599](#) [12589](#) [16599](#)
[10937 \(BLX13\)](#) [13189](#) [12592](#) [12591](#) [20199](#) [10946 \(BLX6MM\)](#) [10936 \(BLX12\)](#) [10999 \(BLX9MM\)](#)