

Features

- Any frequency between 220.000001 MHz and 725 MHz accurate to 6 decimal places
- Widest pull range options: ± 25 , ± 50 , ± 80 , ± 100 , ± 150 , ± 200 , ± 400 , ± 800 , ± 1600 , ± 3200 ppm
- 0.23 ps RMS phase jitter (typ) over 12 kHz to 20 MHz bandwidth
- Wide temperature range support from -40°C to 85°C
Contact [SiTime](#) for other temperature range options
- Industry-standard packages: 3.2 x 2.5, 7.0 x 5.0 mm
Contact [SiTime](#) for 5.0 x 3.2 mm package
- For frequencies 1 MHz to 220 MHz, refer to [SiT3372](#)

Applications

- Cable Modem Termination System (CMTS), Video, Broadcasting System, Audio, Industrial Sensors, Remote Radio Head (RRH)
- SATA, SAS, 10GB Ethernet, Fibre Channel, PCI-Express
- Optical Transport Network (OTN)



Electrical Characteristics

All Min and Max limits in the Electrical Characteristics tables are specified over temperature and rated operating voltage with standard output termination show in the termination diagrams. Typical values are at 25°C and nominal supply voltage.

Table 1. Electrical Characteristics – Common to LVPECL, LVDS and HCSL

Parameter	Symbol	Min.	Typ.	Max.	Unit	Condition
Frequency Range						
Output Frequency Range	f	220.000001	–	725	MHz	Accurate to 6 decimal places
Frequency Stability						
Frequency Stability	F _{stab}	-15	–	+15	ppm	Inclusive of initial tolerance, operating temperature, rated power supply voltage, load variations, and first year aging at 25°C . Contact SiTime for ± 15 ppm.
		-20	–	+20	ppm	
		-30	–	+30	ppm	Inclusive of initial tolerance, operating temperature, rated power supply voltage, load variations, and first year aging at 25°C .
		-50	–	+50	ppm	
Temperature Range						
Operating Temperature Range	T _{use}	-20	–	+70	$^{\circ}\text{C}$	Extended Commercial
		-40	–	+85	$^{\circ}\text{C}$	Industrial. Contact SiTime for other temperature range options.
Supply Voltage						
Supply Voltage	V _{dd}	2.97	3.3	3.63	V	
		2.7	3.0	3.3	V	
		2.52	2.8	3.08	V	
		2.25	2.5	2.75	V	
Voltage Control Characteristics						
Pull Range	PR	± 25 , ± 50 , ± 80 , ± 100 , ± 150 , ± 200 , ± 400 , ± 800 , ± 1600 , ± 3200 ppm			ppm	See the APR (Absolute Pull Range) Table 11 Contact SiTime for custom pull range options.
Upper Control Voltage	VC _U	90%	–	–	V _{dd}	Voltage at which maximum frequency deviation is guaranteed
Lower Control Voltage	VC _L	–	–	10%	V _{dd}	Voltage at which minimum frequency deviation is guaranteed
Control Voltage Input Impedance	VC _z	–	10	–	M Ω	
Control Voltage Input Bandwidth	V _c	–	10	–	kHz	Contact SiTime for other input bandwidth options
Pull Range Linearity	Lin	–	–	1.0	%	
Frequency Change Polarity	–	Positive Slope			–	
Input Characteristics						
Input Voltage High	VIH	70%	–	–	V _{dd}	Pin 2, OE
Input Voltage Low	VIL	–	–	30%	V _{dd}	Pin 2, OE
Input Pull-up Impedance	Z _{in}	–	100	–	k Ω	Pin 2, OE logic high or logic low
Output Characteristics						
Duty Cycle	DC	45	–	55	%	
Startup and OE Timing						
Start-up Time	T _{start}	–	–	3.0	ms	Measured from the time V _{dd} reaches its rated minimum value.
OE Enable/Disable Time	T _{oe}	–	–	3.8	μs	

Table 2. Pin Description

Pin	Symbol	Functionality	
1	VIN	Input	Control Voltage
2	NC/OE	No Connect (NC)	No Connect: Leave floating or connect to GND for better heat dissipation. NC for all 3.2 x 2.5 mm package options.
		Output Enable (OE)	H ^[1,2] : specified frequency output L: output is high impedance. Only output driver is disabled. OE function only available on 7050 package. Pin 2 on 3225 package is NC.
3	GND	Power	Vdd Power Supply Ground
4	OUT+	Output	Oscillator output
5	OUT-	Output	Complementary oscillator output
6	Vdd	Power	Power supply voltage ^[3]

Top View

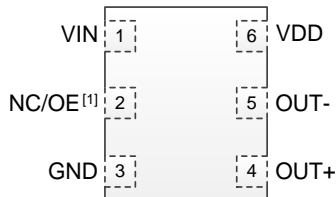

Figure 1. Pin Assignments (7.0 x 5.0 mm package)

Top View

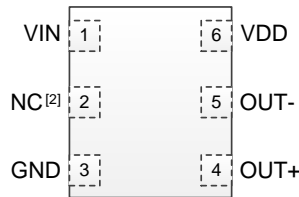

Figure 2. Pin Assignments (3.2 x 2.5 mm package)

Notes:

1. OE mode is only available in the 7050 package. 3225 package is NC.
2. A pull-up resistor of 10 kΩ or less is recommended if pin 1 is not externally driven.
3. A capacitor of value 0.1 μF or higher between Vdd and GND is required. An additional 10 μF capacitor between Vdd and GND is required for the best phase jitter performance.

Table 3. Electrical Characteristics – LVPECL Specific

Parameter	Symbol	Min.	Typ.	Max.	Unit	Condition
Current Consumption						
Current Consumption	I _{dd}	–	–	97	mA	Excluding Load Termination Current, Vdd = 3.3V or 2.5V
OE Disable Supply Current	I _{OE}	–	–	63	mA	OE = Low
Output Disable Leakage Current	I _{leak}	–	0.15	–	μA	OE = Low
Maximum Output Current	I _{driver}	–	–	32	mA	Maximum average current drawn from OUT+ or OUT-
Output Characteristics						
Output High Voltage	VOH	Vdd-1.1	–	Vdd-0.7	V	See Figure 3
Output Low Voltage	VOL	Vdd-1.9	–	Vdd-1.5	V	See Figure 3
Output Differential Voltage Swing	V _{Swing}	1.2	1.6	2.0	V	See Figure 4
Rise/Fall Time	Tr, Tf	–	225	290	ps	20% to 80%, see Figure 3
Jitter						
RMS Phase Jitter (random)	T _{phj}	–	0.225	0.270	ps	f = 322.265625 MHz, Integration bandwidth = 12 kHz to 20 MHz, all Vdd levels, includes spurs. 7.0 x 5.0 mm package.
		–	0.225	0.275	ps	f = 322.265625 MHz, Integration bandwidth = 12 kHz to 20 MHz, all Vdd levels, includes spurs. 3.2 x 2.5 mm package.
		–	0.1	–	ps	f = 322.265625 MHz, IEEE802.3-2005 10GbE jitter mask integration bandwidth = 1.875 MHz to 20 MHz, all Vdd levels, includes spurs.
RMS Period Jitter^[4]	T _{jitt}	–	1.0	1.6	ps	f = 322.265625 MHz, Vdd = 3.3V or 2.5V

Table 4. Electrical Characteristics – LVDS Specific

Parameter	Symbol	Min.	Typ.	Max.	Unit	Condition
Current Consumption						
Current Consumption	I _{dd}	–	–	89	mA	Excluding Load Termination Current, V _{dd} = 3.3V or 2.5V
OE Disable Supply Current	I _{OE}	–	–	67	mA	OE = Low
Output Disable Leakage Current	I _{leak}	–	0.15	–	μA	OE = Low
Output Characteristics						
Differential Output Voltage	V _{OD}	250	–	450	mV	See Figure 5
V _{OD} Magnitude Change	ΔV _{OD}	–	–	50	mV	See Figure 5
Offset Voltage	V _{OS}	1.125	–	1.375	V	See Figure 5
V _{OS} Magnitude Change	ΔV _{OS}	–	–	50	mV	See Figure 5
Rise/Fall Time	T _r , T _f	–	370	470	ps	Measured with 2 pF capacitive loading to GND, 20% to 80%, see Figure 5
Jitter						
RMS Phase Jitter (random)	T _{phj}	–	0.215	0.265	ps	f = 322.265625 MHz, Integration bandwidth = 12 kHz to 20 MHz, all V _{dd} levels, includes spurs. 7.0 x 5.0 mm package.
		–	0.235	0.282	ps	f = 322.265625 MHz, Integration bandwidth = 12 kHz to 20 MHz, all V _{dd} levels, includes spurs. 3.2 x 2.5 mm package.
		–	0.1	–	ps	f = 322.265625 MHz, IEEE802.3-2005 10GbE jitter mask integration bandwidth = 1.875 MHz to 20 MHz, all V _{dd} levels, includes spurs.
RMS Period Jitter ^[4]	T _{jitt}	–	0.92	1.6	ps	f = 322.265625 MHz, V _{dd} = 3.3V or 2.5V

Table 5. Electrical Characteristics – HCSL

Parameter	Symbol	Min.	Typ.	Max.	Unit	Condition
Current Consumption						
Current Consumption	I _{dd}	–	–	102	mA	Excluding Load Termination Current, V _{dd} = 3.3V or 2.5V
OE Disable Supply Current	I _{OE}	–	–	67	mA	OE = Low
Output Disable Leakage Current	I _{leak}	–	0.15	–	μA	OE = Low
Maximum Output Current	I _{driver}	–	–	36	mA	Maximum average current drawn from OUT+ or OUT-
Output Characteristics						
Output High Voltage	V _{OH}	0.6	–	0.90	V	See Figure 3
Output Low Voltage	V _{OL}	-0.05	–	0.08	V	See Figure 3
Output Differential Voltage Swing	V _{Swing}	1.2	1.4	1.8	V	See Figure 4
Rise/Fall Time	T _r , T _f	–	360	470	ps	Measured with 2 pF capacitive loading to GND, 20% to 80%, see Figure 3
Jitter						
RMS Phase Jitter (random)	T _{phj}	–	0.215	0.270	ps	f = 322.265625 MHz, Integration bandwidth = 12 kHz to 20 MHz, all V _{dd} levels, includes spurs. 7.0 x 5.0 mm package.
		–	0.225	0.275	ps	f = 322.265625 MHz, Integration bandwidth = 12 kHz to 20 MHz, all V _{dd} levels, includes spurs. 3.2 x 2.5 mm package.
		–	0.1	–	ps	f = 322.265625 MHz, IEEE802.3-2005 10GbE jitter mask integration bandwidth = 1.875 MHz to 20 MHz, all V _{dd} levels, includes spurs.
RMS Period Jitter ^[4]	T _{jitt}	–	1.0	1.6	ps	f = 322.265625 MHz, V _{dd} = 3.3V or 2.5V

Notes:

- Measure according to JESD65B.

Table 6. Absolute Maximum Ratings

Attempted operation outside the absolute maximum ratings may cause permanent damage to the part. Actual performance of the IC is only guaranteed within the operational specifications, not at absolute maximum ratings.

Parameter	Min.	Max.	Unit
Vdd	-0.5	4.0	V
VIH		Vdd + 0.3V	V
VIL	-0.3		V
Storage Temperature	-65	150	°C
Maximum Junction Temperature		130	°C
Soldering Temperature (follow standard Pb-free soldering guidelines)		260	°C

Table 7. Thermal Considerations^[5]

Package	θ_{JA} , 4 Layer Board (°C/W)	θ_{JC} , Bottom (°C/W)
3225, 6-pin	80	30
7050, 6-pin	52	19

Notes:

5. Refer to JESD51 for θ_{JA} and θ_{JC} definitions, and reference layout used to determine the θ_{JA} and θ_{JC} values in the above table.

Table 8. Maximum Operating Junction Temperature^[6]

Max Operating Temperature (ambient)	Maximum Operating Junction Temperature
70°C	95°C
85°C	110°C

Notes:

6. Datasheet specifications are not guaranteed if junction temperature exceeds the maximum operating junction temperature.

Table 9. Environmental Compliance

Parameter	Test Conditions	Value	Unit
Mechanical Shock Resistance	MIL-STD-883F, Method 2002	10,000	g
Mechanical Vibration Resistance	MIL-STD-883F, Method 2007	70	g
Soldering Temperature (follow standard Pb free soldering guidelines)	MIL-STD-883F, Method 2003	260	°C
Moisture Sensitivity Level	MSL1 @ 260°C		
Electrostatic Discharge (HBM)	HBM, JESD22-A114	2,000	V
Charge-Device Model ESD Protection	JESD220C101	750	V
Latch-up Tolerance	JESD78 Compliant		

Waveform Diagrams

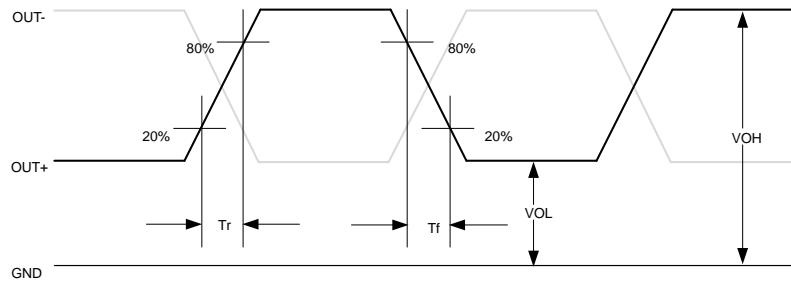

Figure 3. LVPECL/HCSL Voltage Levels per Differential Pin (OUT+/OUT-)

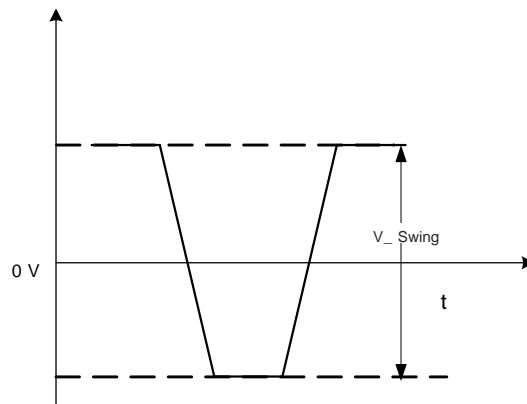

Figure 4. LVPECL/HCSL Voltage Levels across Differential Pair

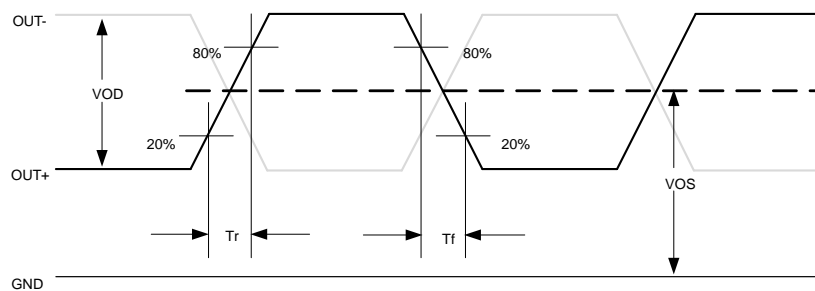

Figure 5. LVDS Voltage Levels per Differential Pin (OUT+/OUT-)

Termination Diagrams

LVPECL:

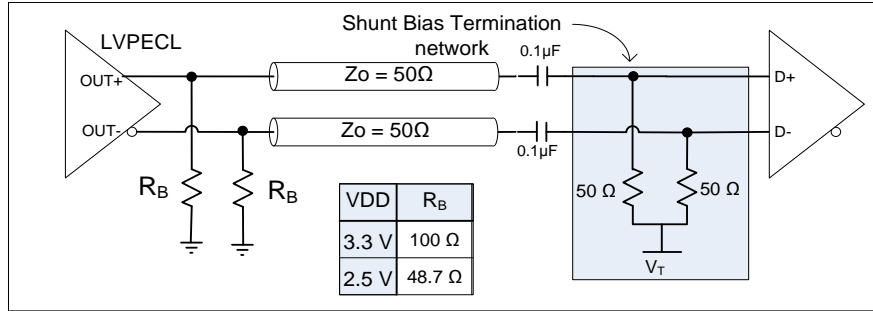

Figure 6. LVPECL with AC-coupled termination

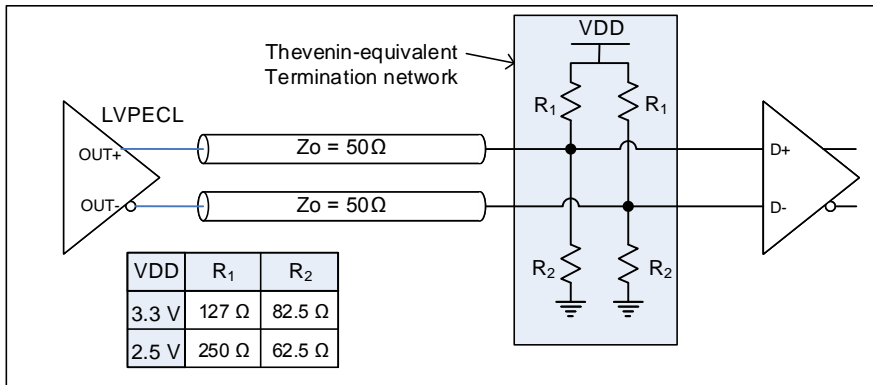

Figure 7. LVPECL DC-coupled load termination with Thevenin equivalent network

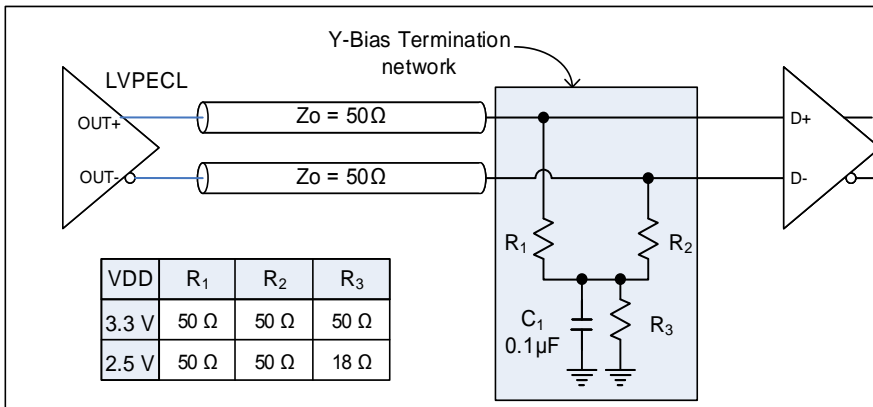

Figure 8. LVPECL with Y-Bias termination

Termination Diagrams (continued)

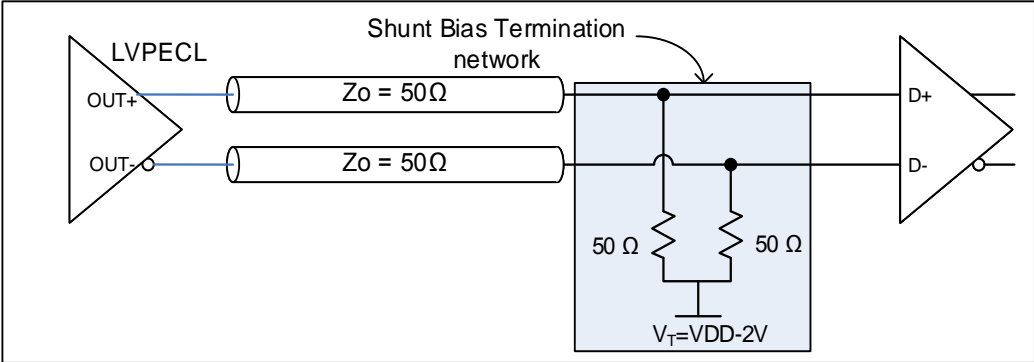

Figure 9. LVPECL with DC-coupled parallel shunt load termination

Termination Diagrams (continued)

LVDS:

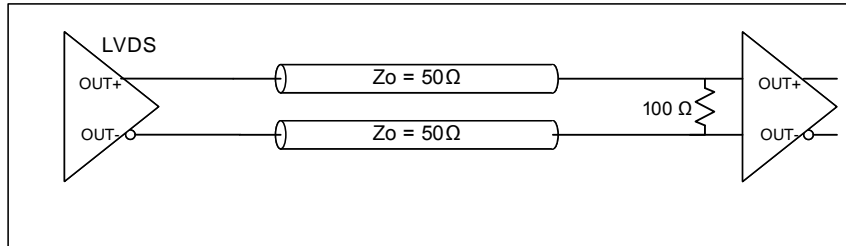

Figure 10. LVDS single DC termination at the load

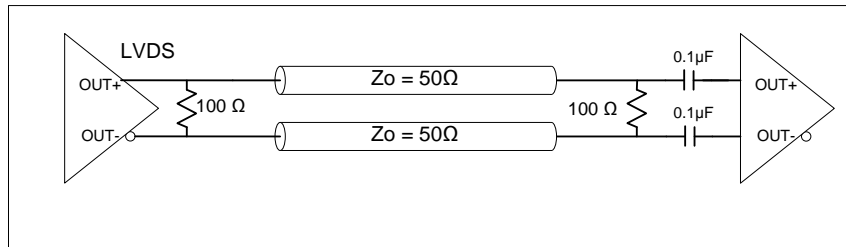

Figure 11. LVDS double AC termination with capacitor close to the load

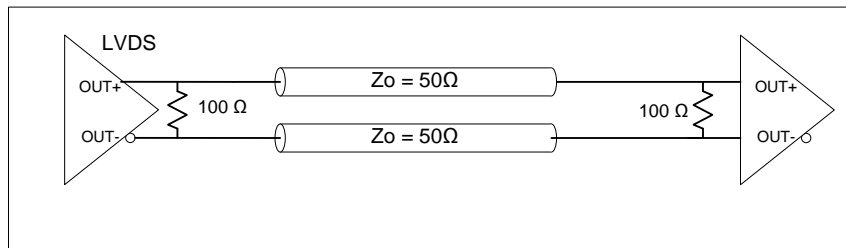

Figure 12. LVDS double DC termination

Termination Diagrams (continued)

HCSL:

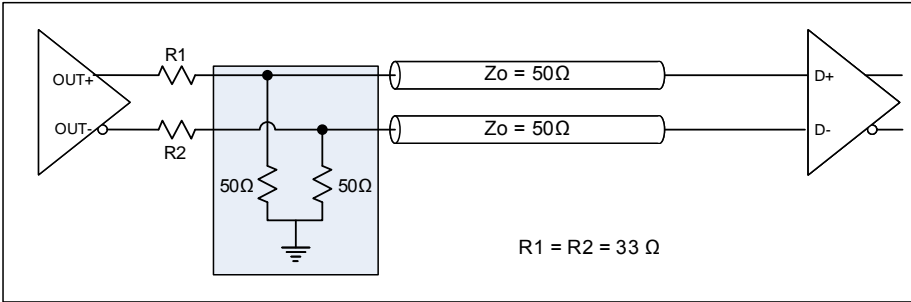

Figure 13. HCSL interface termination

Dimensions and Patterns

Package Size – Dimensions (Unit: mm) ^[7]	Recommended Land Pattern (Unit: mm) ^[8]																																																					
<p>3.2 x 2.5 x 0.75 mm</p> <table border="1" style="margin-left: auto; margin-right: auto;"> <caption>Dimension Table</caption> <thead> <tr> <th></th> <th>Symbol</th> <th>Min</th> <th>Nom</th> <th>Max</th> </tr> </thead> <tbody> <tr> <td>TOTAL THICKNESS</td> <td>A</td> <td>0.800</td> <td>0.850</td> <td>0.900</td> </tr> <tr> <td rowspan="2">BODY SIZE</td> <td>X</td> <td>D</td> <td>2.400</td> <td>2.500</td> <td>2.600</td> </tr> <tr> <td>Y</td> <td>E</td> <td>3.200</td> <td>3.200</td> <td>3.300</td> </tr> <tr> <td>LEAD PITCH</td> <td>e</td> <td colspan="3">1.100 BSC</td> </tr> <tr> <td>LEAD LENGTH</td> <td>L</td> <td>0.650</td> <td>0.700</td> <td>0.750</td> </tr> <tr> <td>LEAD WIDTH</td> <td>W</td> <td>0.550</td> <td>0.600</td> <td>0.650</td> </tr> </tbody> </table> <div style="text-align: right; margin-top: 10px;"> <table border="1"> <tr> <td>6L QFN</td> <td>Package Outline</td> </tr> <tr> <td>3.2 x 2.5 x 0.75 mm</td> <td></td> </tr> <tr> <td>POD-38 Rev A</td> <td></td> </tr> </table> </div>		Symbol	Min	Nom	Max	TOTAL THICKNESS	A	0.800	0.850	0.900	BODY SIZE	X	D	2.400	2.500	2.600	Y	E	3.200	3.200	3.300	LEAD PITCH	e	1.100 BSC			LEAD LENGTH	L	0.650	0.700	0.750	LEAD WIDTH	W	0.550	0.600	0.650	6L QFN	Package Outline	3.2 x 2.5 x 0.75 mm		POD-38 Rev A		<p>3.2 x 2.5 x 0.75 mm</p>											
	Symbol	Min	Nom	Max																																																		
TOTAL THICKNESS	A	0.800	0.850	0.900																																																		
BODY SIZE	X	D	2.400	2.500	2.600																																																	
	Y	E	3.200	3.200	3.300																																																	
LEAD PITCH	e	1.100 BSC																																																				
LEAD LENGTH	L	0.650	0.700	0.750																																																		
LEAD WIDTH	W	0.550	0.600	0.650																																																		
6L QFN	Package Outline																																																					
3.2 x 2.5 x 0.75 mm																																																						
POD-38 Rev A																																																						
<p>7.0 x 5.0 x 0.90 mm^[9]</p> <table border="1" style="margin-left: auto; margin-right: auto;"> <caption>Dimension Table</caption> <thead> <tr> <th></th> <th>Symbol</th> <th>Min</th> <th>Nom</th> <th>Max</th> </tr> </thead> <tbody> <tr> <td>TOTAL THICKNESS</td> <td>A</td> <td>0.800</td> <td>0.850</td> <td>0.900</td> </tr> <tr> <td rowspan="2">BODY SIZE</td> <td>X</td> <td>D</td> <td>4.900</td> <td>5.000</td> <td>5.100</td> </tr> <tr> <td>Y</td> <td>E</td> <td>6.900</td> <td>7.000</td> <td>7.100</td> </tr> <tr> <td rowspan="2">EP SIZE</td> <td>X</td> <td>J</td> <td>1.400</td> <td>1.500</td> <td>1.600</td> </tr> <tr> <td>Y</td> <td>K</td> <td>3.400</td> <td>3.500</td> <td>3.600</td> </tr> <tr> <td>LEAD PITCH</td> <td>e</td> <td colspan="3">2.540 BSC</td> </tr> <tr> <td>LEAD LENGTH</td> <td>L</td> <td>0.850</td> <td>0.900</td> <td>0.950</td> </tr> <tr> <td>LEAD WIDTH</td> <td>W</td> <td>1.350</td> <td>1.400</td> <td>1.450</td> </tr> </tbody> </table> <div style="text-align: right; margin-top: 10px;"> <table border="1"> <tr> <td>6L QFN</td> <td>Package Outline</td> </tr> <tr> <td>7.0 x 5.0 x 0.90 mm</td> <td></td> </tr> <tr> <td>POD-37 Rev A</td> <td></td> </tr> </table> </div>		Symbol	Min	Nom	Max	TOTAL THICKNESS	A	0.800	0.850	0.900	BODY SIZE	X	D	4.900	5.000	5.100	Y	E	6.900	7.000	7.100	EP SIZE	X	J	1.400	1.500	1.600	Y	K	3.400	3.500	3.600	LEAD PITCH	e	2.540 BSC			LEAD LENGTH	L	0.850	0.900	0.950	LEAD WIDTH	W	1.350	1.400	1.450	6L QFN	Package Outline	7.0 x 5.0 x 0.90 mm		POD-37 Rev A		<p>7.0 x 5.0 x 0.90 mm^[9]</p> <p>Note: Circles in center pad are thermal vias, recommended to improve thermal performance</p>
	Symbol	Min	Nom	Max																																																		
TOTAL THICKNESS	A	0.800	0.850	0.900																																																		
BODY SIZE	X	D	4.900	5.000	5.100																																																	
	Y	E	6.900	7.000	7.100																																																	
EP SIZE	X	J	1.400	1.500	1.600																																																	
	Y	K	3.400	3.500	3.600																																																	
LEAD PITCH	e	2.540 BSC																																																				
LEAD LENGTH	L	0.850	0.900	0.950																																																		
LEAD WIDTH	W	1.350	1.400	1.450																																																		
6L QFN	Package Outline																																																					
7.0 x 5.0 x 0.90 mm																																																						
POD-37 Rev A																																																						

Notes:

7. Top Marking: Y denotes manufacturing origin and XXXX denotes manufacturing lot number. The value of "Y" will depend on the assembly location of the device.
8. A capacitor of value 0.1 μ F or higher between Vdd and GND is required. An additional 10 μ F capacitor between Vdd and GND is required for the best phase jitter performance
9. The center pad has no electrical function. Soldering down the center pad to the GND is recommended for best thermal dissipation, but is optional.

Ordering Information

SiT3373AC-1B2-33NH220.123456T

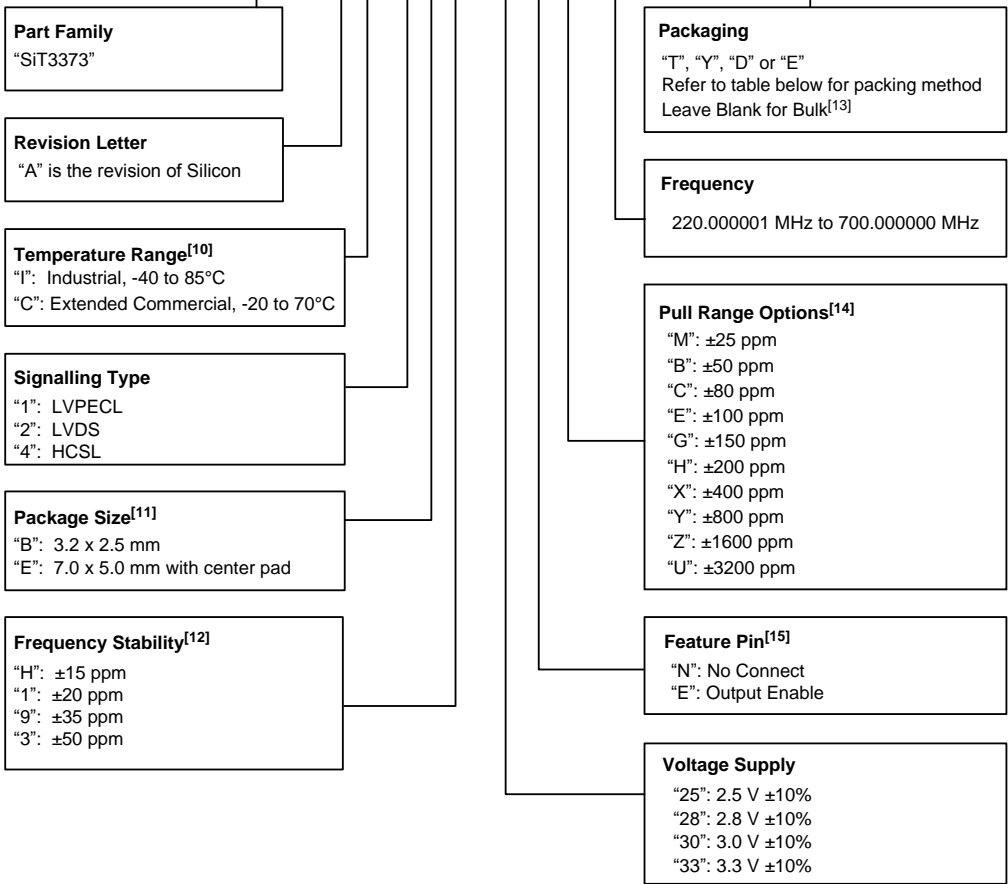

- Notes:**
- 10. Contact [SiTime](#) for higher temperature options
 - 11. Contact [SiTime](#) for 5.0 x 3.2 package
 - 12. Contact [SiTime](#) for ±15 ppm
 - 13. Bulk is available for sampling only
 - 14. Contact [SiTime](#) for custom pull range options
 - 15. "E": Output Enable function is only available in 7.0 x 5.0 mm package

Table 10. Ordering Codes for Supported Tape & Reel Packing Method

Device Size (mm x mm)	8 mm T&R (3ku)	8 mm T&R (1ku)	12 mm T&R (3ku)	12 mm T&R (1ku)	16 mm T&R (3ku)	16 mm T&R (1ku)
7.0 x 5.0	—	—	—	—	T	Y
3.2 x 2.5	D	E	T	Y	—	—

Table 11. APR Table

Absolute pull range (APR) = Nominal pull range (PR) - frequency stability (F_stab)

Nominal Pull Range	Frequency Stability			
	± 15	± 25	± 35	±50
	APR (ppm)			
± 25	± 5	—	—	—
± 50	± 30	± 20	± 10	—
± 80	± 60	± 50	± 40	± 25
± 100	± 80	± 70	± 60	± 45
± 150	± 130	± 120	± 110	± 95
± 200	± 180	± 170	± 160	± 145
± 400	± 380	± 370	± 360	± 345
± 800	± 780	± 770	± 760	± 745
± 1600	± 1580	± 1570	± 1560	± 1545
± 3200	± 3180	± 3170	± 3160	± 3145

Table 12. Additional Information

Document	Description	Download Link
ECCN #: EAR99	Five character designation used on the commerce Control List (CCL) to identify dual use items for export control purposes.	—
Part number Generator	Tool used to create the part number based on desired features.	—
Time Machine II	MEMS oscillator programmer	http://www.sitime.com/support/time-machine-oscillator-programmer
Field Programmable Oscillators	Devices that can be programmable in the field by Time Machine II	http://www.sitime.com/products/field-programmable-oscillators
Manufacturing Notes	Tape & Reel dimension, reflow profile and other manufacturing related info	http://www.sitime.com/component/docman/doc_download/243-manufacturing-notes-for-sitime-oscillators
Qualification Reports	RoHS report, reliability reports, composition reports	http://www.sitime.com/support/quality-and-reliability
Performance Reports	Additional performance data such as phase noise, current consumption and jitter for selected frequencies	http://www.sitime.com/support/performance-measurement-report
Termination Techniques	Termination design recommendations	http://www.sitime.com/support/application-notes
Layout Techniques	Layout recommendations	http://www.sitime.com/support/application-notes

Table 13. Revision History

Revision	Release Date	Change Summary
1.0	09/30/2017	Initial release

SiTime Corporation, 5451 Patrick Henry Drive, Santa Clara, CA 95054, USA | Phone: +1-408-328-4400 | Fax: +1-408-328-4439

© SiTime Corporation 2017. The information contained herein is subject to change at any time without notice. SiTime assumes no responsibility or liability for any loss, damage or defect of a Product which is caused in whole or in part by (i) use of any circuitry other than circuitry embodied in a SiTime product, (ii) misuse or abuse including static discharge, neglect or accident, (iii) unauthorized modification or repairs which have been soldered or altered during assembly and are not capable of being tested by SiTime under its normal test conditions, or (iv) improper installation, storage, handling, warehousing or transportation, or (v) being subjected to unusual physical, thermal, or electrical stress.

Disclaimer: SiTime makes no warranty of any kind, express or implied, with regard to this material, and specifically disclaims any and all express or implied warranties, either in fact or by operation of law, statutory or otherwise, including the implied warranties of merchantability and fitness for use or a particular purpose, and any implied warranty arising from course of dealing or usage of trade, as well as any common-law duties relating to accuracy or lack of negligence, with respect to this material, any SiTime product and any product documentation. Products sold by SiTime are not suitable or intended to be used in a life support application or component, to operate nuclear facilities, or in other mission critical applications where human life may be involved or at stake. All sales are made conditioned upon compliance with the critical uses policy set forth below.

CRITICAL USE EXCLUSION POLICY

BUYER AGREES NOT TO USE SITIME'S PRODUCTS FOR ANY APPLICATION OR IN ANY COMPONENTS USED IN LIFE SUPPORT DEVICES OR TO OPERATE NUCLEAR FACILITIES OR FOR USE IN OTHER MISSION-CRITICAL APPLICATIONS OR COMPONENTS WHERE HUMAN LIFE OR PROPERTY MAY BE AT STAKE.

SiTime owns all rights, title and interest to the intellectual property related to SiTime's products, including any software, firmware, copyright, patent, or trademark. The sale of SiTime products does not convey or imply any license under patent or other rights. SiTime retains the copyright and trademark rights in all documents, catalogs and plans supplied pursuant to or ancillary to the sale of products or services by SiTime. Unless otherwise agreed to in writing by SiTime, any reproduction, modification, translation, compilation, or representation of this material shall be strictly prohibited.

X-ON Electronics

Largest Supplier of Electrical and Electronic Components

Click to view similar products for [sitime manufacturer](#):

Other Similar products are found below :

[SiT6100DK](#) [SiT8920AM-31-33N-40.000000](#) [SiT8103AI-22-33E-33.33300X](#) [9121AI-2C2-25E200.000000](#) [9121AC-2C3-25E100.000000](#)
[9102AI-233N25E200.000000](#) [9102AC-283N25E200.000000](#) [SiT1602AI-32-33E-50.000000X](#) [SIT5000AICGE-33N0-25.000000X](#) [SiT3808AI-](#)
[C2-33E-27.000000D](#) [SiT8008BI-72-33E-30.000000](#) [SiT8008BI-72-33E-31.250000](#) [SiT8008BI-72-33E-33.000000](#) [SiT8008BI-72-33E-](#)
[48.000000](#) [SiT8008BI-72-33E-66.000000](#) [SiT8008BI-72-33E-66.600000](#) [SiT8008BI-72-33E-66.660000](#) [SiT8008BI-72-33E-66.666000](#)
[SiT8008BI-72-33E-74.176000](#) [SiT8008BI-72-33E-77.760000](#) [SiT1602BI-72-33E-7.372800](#) [SiT1602BI-72-33E-10.000000](#) [SiT1602BI-72-](#)
[33E-24.576000](#) [SiT1602BI-72-33E-33.300000](#) [SiT1602BI-72-33E-40.500000](#) [SiT1602BI-72-33E-54.000000](#) [SiT1602BI-72-33E-66.666000](#)
[SiT1602BI-72-33E-66.666600](#) [SiT1602BI-72-33E-66.666660](#) [SiT1602BI-72-33E-77.760000](#) [SiT8008BI-72-33E-20.000000](#) [SiT8008BI-72-](#)
[33E-32.768000](#) [SiT8008BI-72-33E-37.500000](#) [SiT8008BI-72-33E-40.500000](#) [SiT8008BI-72-33E-74.250000](#) [SiT1602BI-72-33E-33.330000](#)
[SiT1602BI-72-33E-60.000000](#) [SiT1602BI-72-33E-66.660000](#) [SIT8103AI-88-33E-25.000000Z](#) [SIT8103AC-82-18E-16.384000Z](#) [SiT8008AI-](#)
[11-18E-27.000000E](#) [SiT8008BI-82-33E-25.000625](#) [SiT8008BI-82-33E-28.636300](#) [SiT8008BI-82-33E-33.333300](#) [SiT8008BI-82-33E-](#)
[60.000000](#) [SiT8008BI-82-33E-65.000000](#) [SiT8008BI-82-33E-66.666600](#) [SiT8008BI-82-33E-66.666660](#) [SiT8008BI-82-33E-74.175824](#)
[SiT1602BI-82-33E-1.000000](#)