

# 'DIN RAIL' RADIO REMOTE CONTROL

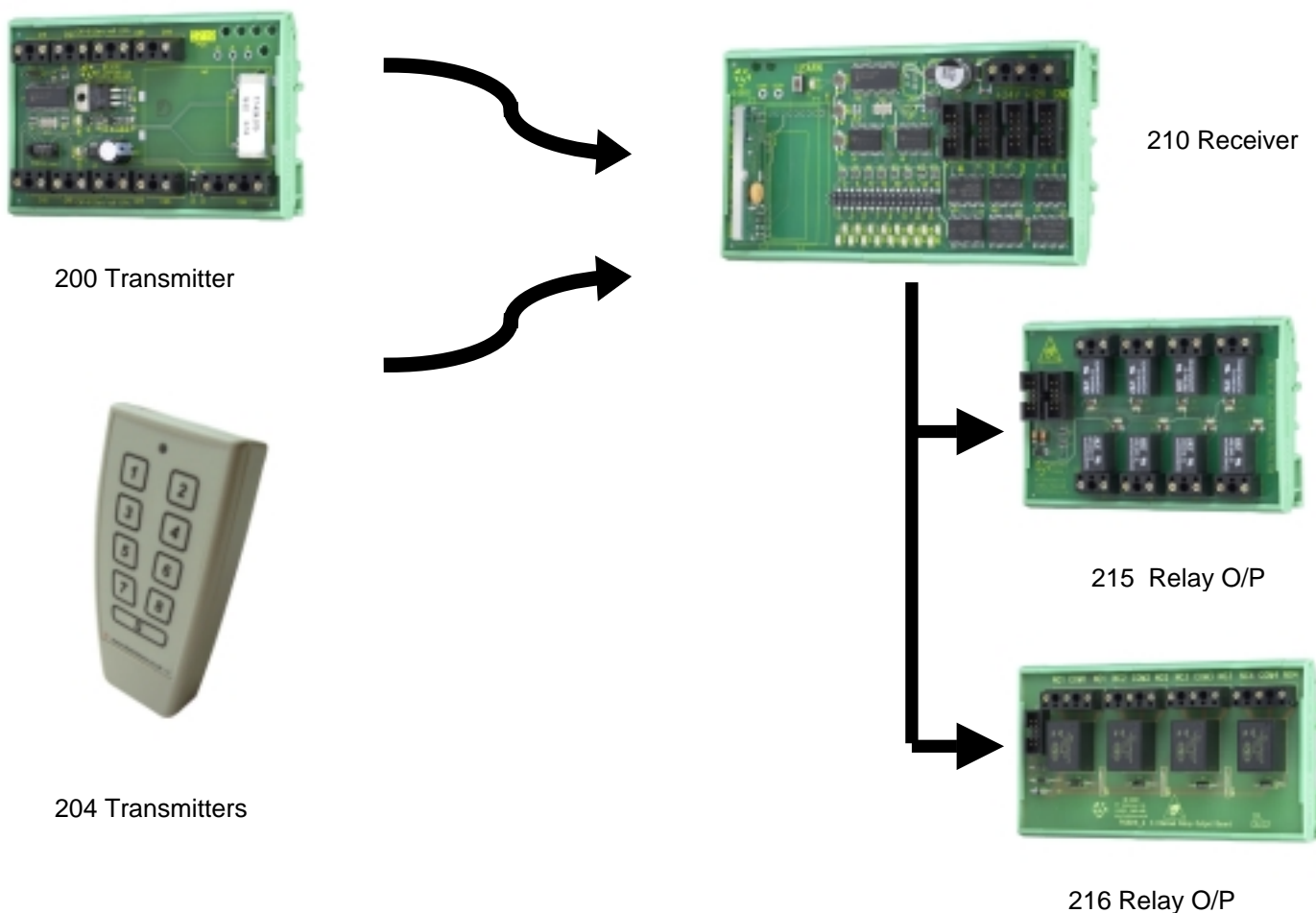

- Upto 16 Output Channels, Modular Design,
- Outputs can be
  - Momentary
  - Latching
  - Timed (up to 15 mins.)
  - Dimming
- 12 / 24Vdc Supply
- LED Indication of each channel.
- Easy Configuration of any transmitter switch to any output channel
- Range;
  - 433MHz Upto 200 Metres
  - 458MHz Upto 4,000 Metres
- Up to 48 Transmitters per system

- This flexible Radio Remote control system may be constructed by simply plugging together the desired modules.
- The transmitters are supplied as either a hand held fob or DIN Rail mounting Telemetry Module.
- The 210Rx Module performs the RF reception and decoding. It has 16 outputs.
- Any combination of the Output Modules below may be connected to the 210Rx module to utilise the full 16 outputs.
- Output module 215 provides 8 relay outputs rate 3A at 230Vac
- Output module 216 provides 4 relay outputs rate 5A (12Apk) at 230Vac
- Output Module 217 module provides 4 phase controlled outputs rated 230V at 250W each. (for dimming lighting circuits etc).



# 'DIN RAIL' RADIO REMOTE CONTROL

- Requires no Radio License

## Transmitter Encoders

### 200 DIN Rail Transmitter

- 8 Input Channels controlling up to 15 outputs
- Volt Free contact Inputs via Screw Terminals
- 12 / 24Vdc Supply
- Range;
  - 433MHz Upto 200 Metres
  - 458MHz Upto 4,000 Metres
- High Security RF Protocol
- Auto Transmit Mode
- Automatic Watchdog Transmission



### 204 Hand Held Transmitter

- Pocket Fob with Wall Mounting Holster
- 4, 8 And 16 Switch Versions
- Range : 433 MHz, up to 100 Metres
- Miniature enclosure 96 x 47 x 23
- Two 3V Lithium Cells (CR2016)
- LED Indication of Transmission
- Custom Overlays available



### 206 Series Encoders (Future Product)

- Pocket Fob with Wall Mounting Holster
- 4, 8 And 16 Switch Options Planned
- Range;
  - 433 MHz, up to 200 Metres
- Miniature enclosure 140 x 63 x 32
- LED Indication of Transmission
- Single PP3 Battery



| Part Number | Description                | Freq (MHz) | Range** (Metres) |
|-------------|----------------------------|------------|------------------|
| 204-433FR1  | FM Transmitter 16 Channels | 433.92     | 100              |

### 200 Series Transmitter Module



# 'DIN RAIL' RADIO REMOTE CONTROL

- 8 Zero Volt Inputs controlling up to 15 outputs
- LED Indication of transmission
- Auto Refresh Mode
- 'Watchdog' Mode
- Requires no Radio License

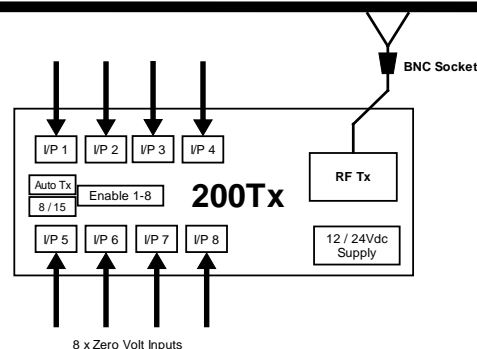

## Description

This is a simple to use radio transmitter module which can accept 8 pairs of 'Volt Free' contacts as inputs via screw terminals. When a contact closure occurs, the 200Tx transmitter will transmit the a data packet over the RF link to an associated 210Rx receiver (that has been learnt to the 200Tx). The 200Tx module continually monitors the status of its 'inputs'. Whenever a change of state is seen on any input the 200Tx module will transmit the status of all inputs.

### Enable Jumper Links (1-8)

The 200Tx has eight 'Enable' Jumper links which must be fitted in order for the corresponding input to be valid (otherwise the 200Tx will ignore it). This enables applications where many 200Tx transmitters are used with a single 210Rx (many to one relationship)

### Operating the 210Rx with a '200 series Transmitter

Each 200Tx has a unique identity (factory set) which must be learnt by the 210Rx.

The 200Tx has 8 inputs which are automatically mapped to the 210Rx as either outputs 1-8 or 9-15 according to the OPT3 jumper link on the 200Tx.as below

| 200Tx Jumper Link OPT3 | 210Rx output Channels |
|------------------------|-----------------------|
| Open                   | 1 – 8                 |
| Connected              | 9 – 15                |

### Auto Transmit with Watchdog Mode 'Auto Tx' (OPT1)

When this link is made, a system 'watchdog' is provided. Channel 16 is used as the watchdog channel which 'releases' if the 210Rx is unable to receive a 200Tx transmitter signal.

With the auto transmit mode jumper in place, the 200Tx module will automatically transmit the status of all enabled inputs (with a small random time delay). This transmission update is in addition to transmission caused by a change of state of any inputs.

The 210Rx watchdog channel 16 relay output is continually operated 'ON', as long as it receives a transmitted signal, if the signal is not received for a period of 10 seconds (e.g. when there is radio interference) then the relay output drops out. The relay automatically recovers on valid signal again. (Therefore channel 16 cannot be used as a standard telemetry channel in this mode)

### License Exemption

The transmitter encoders use EMC compliant radio transmitter modules and complies with ETSI330-220.



# 'DIN RAIL' RADIO REMOTE CONTROL

## Connecting an Antenna

The 210Rx has a 300mm flying lead cable (50ohm) with a panel mount BNC socket provided to mount on an enclosure. This cable may be extended however please note that typically there is a 50% range reduction with every 3metres of coax cable used!

For increasing range performance a +3dB gain antenna is available. This is supplied with wall mounting bracket and 2metres of coax cable, it plugs in directly to the 210Rx BNC connector.

## Technical Specifications

**Dimensions:** Within DIN Rail : 112 x 77 mm (PCB: 109 x 72mm)

Storage Temperature; -10 to +70° Celsius. Operating Temperature; 0 to +55° Celsius.

| <b>Electrical Characteristics</b> | <b>Min</b> | <b>Typical</b> | <b>Max</b> | <b>Units</b> |
|-----------------------------------|------------|----------------|------------|--------------|
| Supply Voltage: 12V Supply        | 10         | 12             | 16         | V            |
| Supply Voltage: 24V Supply        | 21         | 24             | 30         | V            |
| Supply Current :                  |            |                |            |              |
| 433MHz version                    |            | 10             |            | mA           |
| 458MHz version                    | 150        | 170            | 200        |              |
| Antenna Output Lead               |            | 50             |            | ohms         |

## Ordering Information

| <b>Part Number</b> | <b>Description</b>      | <b>Freq (MHz)</b> | <b>Range** (Metres)</b> | <b>Compatible Decoders</b> |
|--------------------|-------------------------|-------------------|-------------------------|----------------------------|
| 200-433FR1         | FM Transmitter 8 inputs | 433.92            | 200                     | 210-433F Series            |
| 200-458FR1         | FM Transmitter 8 inputs | 458.850           | 4,000                   | 210-458F Series            |

\*\* Range stated is optimum, direct line of sight. In worst conditions this can be reduced by upto 50%



# 'DIN RAIL' RADIO REMOTE CONTROL

## Receiver Decoders

### 210 Receiver Module

- RF Receiver & Decoder
- 16 Digital Outputs
- Timed Outputs
- Easy Learn Function

### 215 8 Relay Module

- 8 Relay Outputs rated 3A @230Vac
- Connects Directly to 210 Module
- No other Connections Required

### 216 4 Relay Module

- 4 Relay Outputs rated 5A @230Vac
- Connects Directly to 210 Module
- No other Connections Required

### 217 Dimming Module

- 4 Channel Phase Controlled Dimming Outputs
- Connects Directly to 210 Module

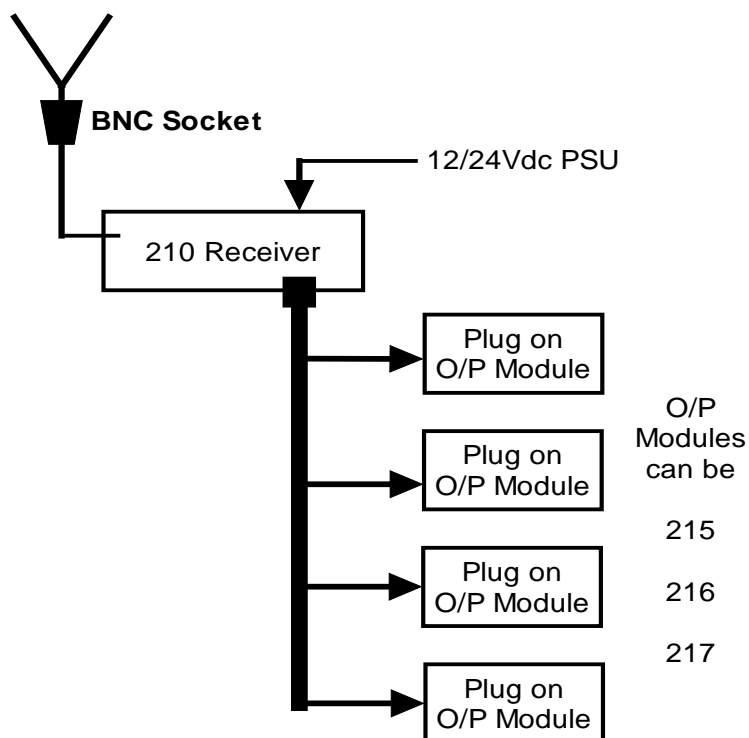

## Description

The 210Rx module performs the RF reception and decoding. It has 16 available outputs arranged as 4 x 4 easy plug in connectors.

From these connectors any one or combination of output modules may be connected (connecting leads supplied) to use some or all of the 16 available outputs.

The only power required by the system is applied to the 210Rx module. Each of the output modules obtains power from the 210 connection internally.

A 110-240 Vac Power supply is available as a separate item along with enclosures for the receiver decoder modules.

# 'DIN RAIL' RADIO REMOTE CONTROL

## '210' Series Receiver Decoder

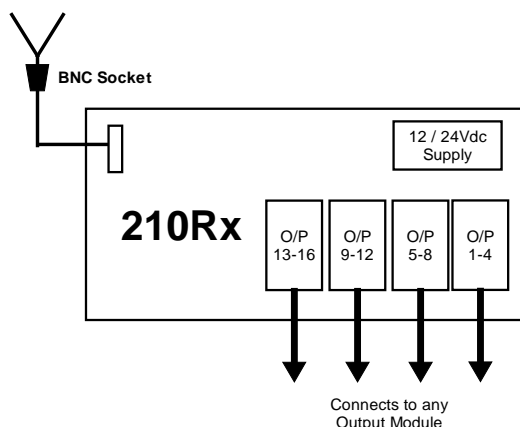

### Description

This DIN rail module performs the radio reception and decoding. It has four output connectors each with four digital outputs and displays the output status on LED's 1 – 16. DIN rail 'Output' modules plug in to connectors marked 1-4 (connecting cable supplied with output module).

| Connector | O/P Channels |
|-----------|--------------|
| 1         | 1 - 4        |
| 2         | 5 – 8        |
| 3         | 9 – 12       |
| 4         | 13 – 16      |

### Initial Configuration of the 210Rx

On initial use the 210Rx must be configured to operate with either the 204 handset transmitter (remote control applications) or the 200 DIN rail transmitter (remote telemetry applications).

1. Ensure option link J8 is open
2. On initially powering up the 210RX the output LEDS flash alternately. The 210Rx is now in configuration mode.
3. The user must operate the transmitter to be used by either;
  - 204 Transmitter: briefly press any switch
  - 200 Transmitter: input activated by shorting any input terminal.
4. The 210Rx receives the transmitter signal and automatically configures itself for use to operate with that type of transmitter and will ignore other types.
  - 204 Transmitter: LED1 flashes 5 times
  - 200 Transmitter: LED2 flashes 5 times
5. Configuration is now complete and now the transmitter unit can be learned to the receiver.

Each time power is applied the 210Rx will now show the mode it is configured to for the first 5 seconds.

| LED | Configured for                |
|-----|-------------------------------|
| 1   | 204 Handsets (remote Control) |
| 2   | 200Tx (remote Telemetry)      |

In the event that no configuration has taken place then on power up LED's 1-16 will flash alternately.



# 'DIN RAIL' RADIO REMOTE CONTROL

---

## Operating the 210 Rx with a '204 series' transmitter.

Each 210 Rx can 'learn' up to 48 transmitter encoders. During the learn process the receiver learns the encoder's unique identity code, and the individual switch number.

This enables a single transmitter switch to operate one or more receiver outputs. This allows many different transmitters to control one receiver output and also one transmitter button to control many 210 Rx outputs. (The only limitation being maximum 48 transmitters to a single receiver)

### To learn a Transmitter Switch to a Receiver Output;

1. Decide which switch on the Transmitter is to operate which output channel on the 210 Receiver decoder.
2. Select the 210Rx output channel by briefly pressing the 210 Rx learn switch (All LEDs flash briefly) until the desired channel is selected (1 thro 16). The 210 Rx LED indicates the currently selected output channel.
3. Operate the desired transmitter switch briefly and the channel LED on the 210Rx will extinguish.
4. Depress the transmitter switch again and the channel LED on the 210Rx will turn on briefly and then extinguish.
5. The learn process is now complete and the selected transmitter switch will now control the associated channel.

E.G. To learn buttons 1 & 2 of the 204 Tx to outputs 1 and 2 of the 210Rx.

- *Depress and release the learn button S1.*
- *All the 210Rx output LEDs flash once and LED1 will illuminate.*
- *Depress and release Button 1 of the of the 204Tx.*
- *Output Led1 of the 210Rx will extinguish.*
- *Depress and release Button 1 of the 204Tx again.*
- *Output Led1 of the 210Rx will illuminate for 1s and then extinguish.*

Button 1 of the 204Tx has now been successfully taught to output 1 of the 210Rx.

- *Depress and release the learn button S1 again.*
- *All the 210Rx output LEDs flash once and LED1 will illuminate.*
- *Depress and release the learn button S1 again.*
- *LED2 will now illuminate.*
- *Depress and release Button 2 of the of the 204Tx.*
- *Output Led2 of the 210Rx will extinguish.*
- *Depress and release Button 2 of the 204Tx again.*
- *Output Led2 of the 210Rx will illuminate for 1s and then extinguish.*

Button 2 of the 204Tx has now been successfully taught to output 1 of the 210Rx.

Follow this procedure to learn all buttons of the 204Tx to all outputs of the 210Rx



# 'DIN RAIL' RADIO REMOTE CONTROL

## Erasing the 210Rx Receiver Decoder's Memory

1. To completely erase the 210Rx decoder's memory, press and hold the 210Rx learn switch. The learn LED will illuminate when the switch is first pressed
2. After a period of 10 seconds the learn LED will turn off. Release the learn button and all the output LEDs will now flash alternately to indicate that all encoder data has been erased.

**Note:** It is not possible to erase individual transmitters.

## Configuration of the Outputs

Links J1-16 configure the operation of the outputs according to the table below. Note that the link status is read only on power up and thus after changing the links, power must be removed and re-applied for the new status to be identified.

| J1 – 16   | O/P 1 – 3      | O/P 4 -16   |
|-----------|----------------|---|
| Open      | Mom or Timed   | Mom (The relay operates for as long as the transmitter switch is held on) |
| Connected | Latch or Timed | Latch (The relay operates until the Transmitter is operated again)        |

## Timed Outputs (O/P1-3)

When the system is configured with 204 Transmitter encoders these outputs can provide variable timed outputs controlled by VR1-3 with an adjustable delay of from zero to 15 minutes.

### Setting the Timed outputs on O/P1-3 (for use with a 204Tx only).

1. Remove power.
2. Place a shorting link header on J8.
3. Apply power and the output LEDs will operate alternately 1 –16 and then repeat.
4. Depress and release the learn button twice.
5. The 210Rx will then enter the time set mode where the timing pots for channels 1, 2 and 3 can be set. Initially LED1 will illuminate. This is to indicate that output 1 timer is to be set. Pressing the learn switch will allow the user to cycle through the three timed outputs. The illuminated LED (1,2 or 3) indicates which channel is being set up.
6. Using a fine screwdriver, adjust potentiometer VR1 for OP1, VR2 for OP2 and VR3 for OP3 .
7. When setting VR1-3, LED's 9-15 give an indication of the % of time delay set (as a bargraph display). If no time delay is required then set all LED's off. For maximum delay set all 7 LED's (9-15) to on.

## Operating the 210Rx with a '200 series' Transmitter

Each 210Rx can learn up to 48, 200Tx encoders and during the learn process the receiver learns the encoder's unique identity code. **Each Transmitter/encoder input has an associated 'enable' option link which must be fitted for that input to operate.**

### To learn a new 200Tx encoder follow this procedure;

Before learning check the following on the 200Tx

1. On the 200Tx, configure the OPT3 '8/15' link. This link maps the 200Tx inputs to the 210Rx outputs. 1-8 with link removed, or 9-15 with link in place.
2. On the 200Tx unit, remove the Link header 'OPT1' (auto Tx). (This prevents automatic transmission during the learn process).
3. On the 200Tx unit, place an enable link on any one of the enable link positions.
4. Briefly press the 210Rx Learn Switch: Note that the 210Rx Learn LED will flash.
5. Wait for the 210Rx LED to stop flashing.





# 'DIN RAIL' RADIO REMOTE CONTROL

- Actuate the enabled 200Tx input (from step 3) by shorting the input terminals (a bent paper clip is ideal!). This causes transmission : Note that the 210Rx learn LED will turn off.
- The learn cycle is now complete and the transmitter/encoder will operate the systems.

### Erasing the 210Rx Receiver Decoder's Memory

- To completely erase the 210Rx decoder's memory, press and hold the 210Rx learn switch. The learn LED will illuminate when the switch is first pressed
- After a period of 10 seconds the learn LED will turn off. Release the learn button and all the output LEDs will now flash alternately to indicate that all encoder data has been erased.

**Note:** It is not possible to erase individual transmitters.

### Watchdog Mode (200Tx Auto Tx Jumper Link OPT3 connected)

When used in conjunction with one or more 200Tx encoders in watchdog mode, relay 16 on the 210Rx is automatically used as the watchdog channel. With the auto Tx link in place, the unit is in watchdog mode and the input status of enabled inputs is automatically transmitted every 3 - 6 seconds and system integrity is thus continuously verified. For further information see the 200 Series Transmitter Module description, above.

### Connecting an Antenna

The 210Rx has a 300mm flying lead cable (50ohm) with a panel mount BNC socket provided to mount on an enclosure. This cable may be extended however please note that typically there is a 50% range reduction with every 3metres of coax cable used!

For increasing range performance a +3dB gain antenna is available. This is supplied with wall mounting bracket and 2metres of coax cable, it plugs in directly to the 210Rx BNC connector.

### Range

The antenna choice and position directly controls the system range. Keep it clear of other metal in the system. The best position by far, is protruding from the top of the product. This is often not desirable for practical or ergonomic reasons and thus a compromise may be needed. If an internal antenna must be used then try to keep it away from other metal items, and in particular large ones like transformers, batteries and PCB tracks and earth planes.

Note that the space around the antenna is as important as the antenna itself. All radio systems are dependant on a radio signal being received through airspace.

The range quoted is the optimal in direct line of sight without obstacles and in good atmospheric conditions. Range is affected by many things, e.g. local environmental conditions, atmospheric conditions, interference from other radio transmitters. For evaluating the local environment please see our RF Meter (DS006) In very worse case applications the range quoted may be reduced to 30% of the optimal range stated.

### Signal integrity

In systems where many encoders are in close proximity there may be occasions when, due to signal overlay between encoders, it is difficult or impossible to guarantee system integrity. In such circumstances it is the responsibility of the installer to ensure that the system performance is adequate for the purposes of the installation.

## Technical Specifications

**Dimensions:** Within DIN Rail : 157 x 77 mm (PCB: 155 x 72mm)

Storage Temperature; -10 to +70° Celsius. Operating Temperature; 0 to +55° Celsius.

| Electrical Characteristics                    | Min | Typical | Max | Units |
|---|-----|---------|-----|-------|
| Supply Voltage: 12V Supply                    | 10  | 12      | 16  | V     |
| Supply Voltage: 24V Supply                    | 21  | 24      | 30  | V     |
| Supply Current : Quiescent                    |     | 25      |     | mA    |
| Time from Tx Switch depressed to 210Rx output |     |         | 100 | mSecs |
| Time from Tx Switch release to Decoder output |     |         | 200 | mSecs |
| Switched output Voltage (I out = 1mA)         |     |         |     |       |



## 'DIN RAIL' RADIO REMOTE CONTROL

|                         |     |     |     |    |
|-------------------------|-----|-----|-----|----|
| Logic Low               | 0   | 0.2 | 0.8 | V  |
| Logic High              | 3.5 | 3.8 | 5   |    |
| Switched output Current |     |     |     |    |
| Logic Low               |     |     |     | mA |
| Logic High              |     |     |     |    |

### Part Numbering

| Part No    | Description  |
|------------|--|
| 210-433R1  | Receiver Decoder 16 Channels DIN Rail Mounting Module 433MHz |
| 210-458R1  | Receiver Decoder 16 Channels DIN Rail Mounting Module 458MHz |
| PSU12V1AIN | Power Supply Unit 110-240Vac input, 12V 1A output            |
| ENC        | Enclosure UP67, with internal mounting plate and DIN Rail.   |



# 'DIN RAIL' RADIO REMOTE CONTROL

## Example of 7 Channel Telemetry system with failsafe

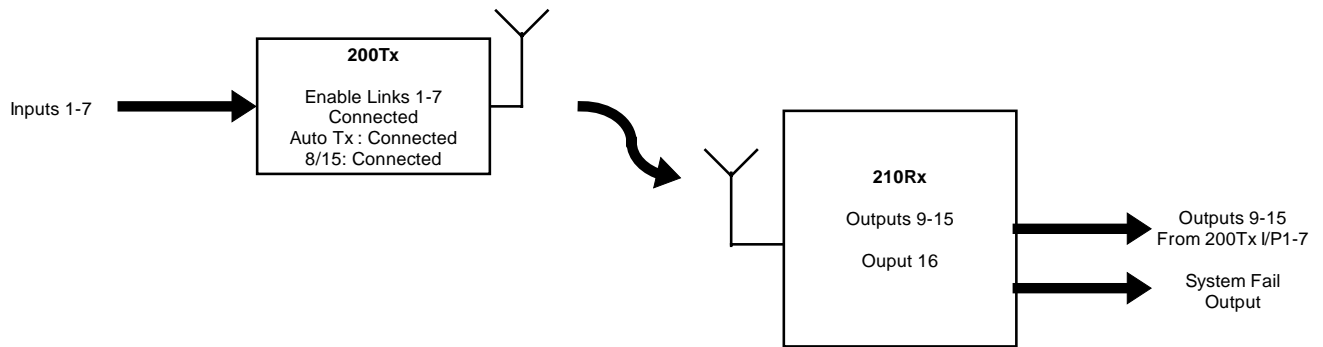

## Example of 15 Outstations to single Receiver System

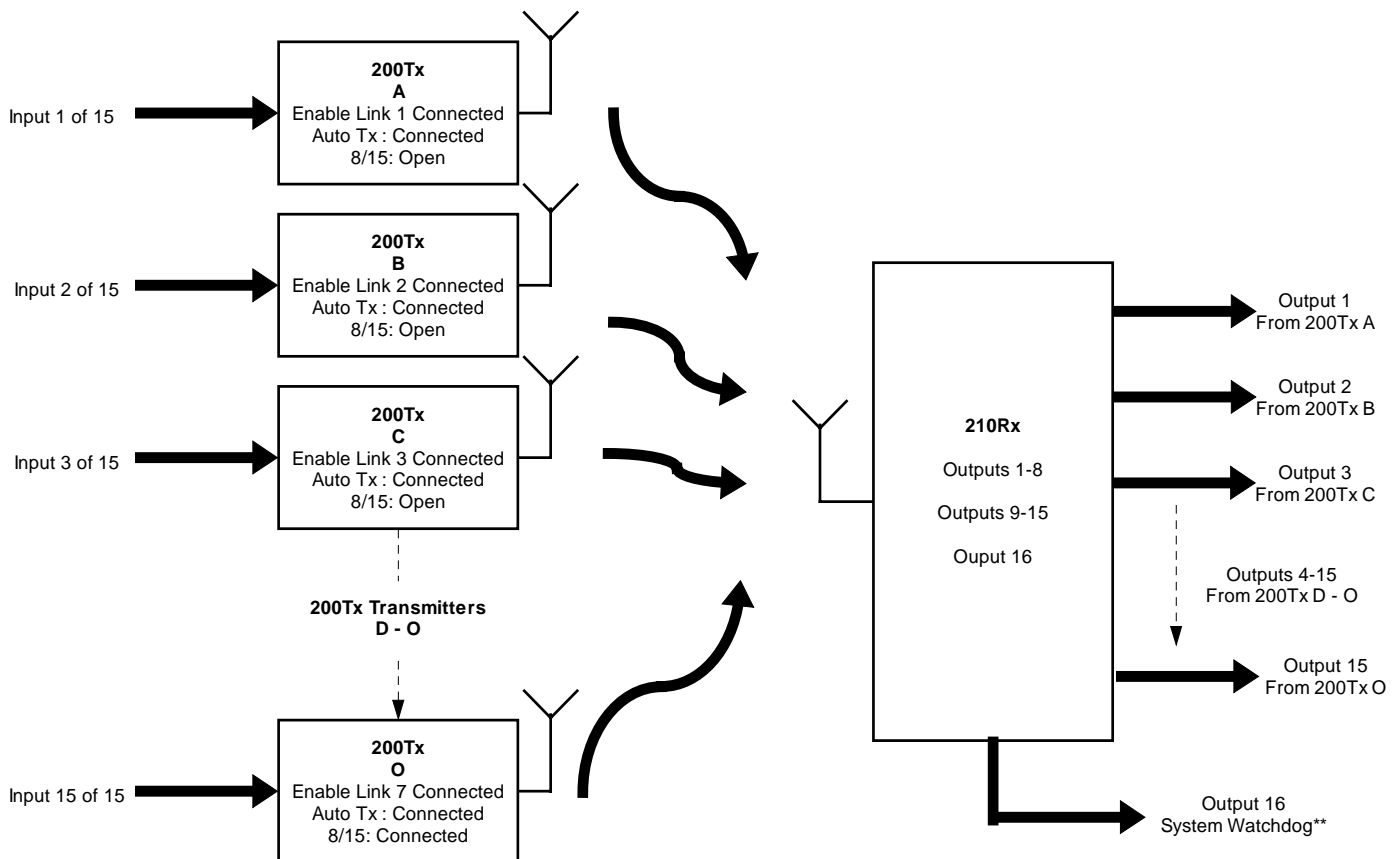

## '215' 8 Relay output Module

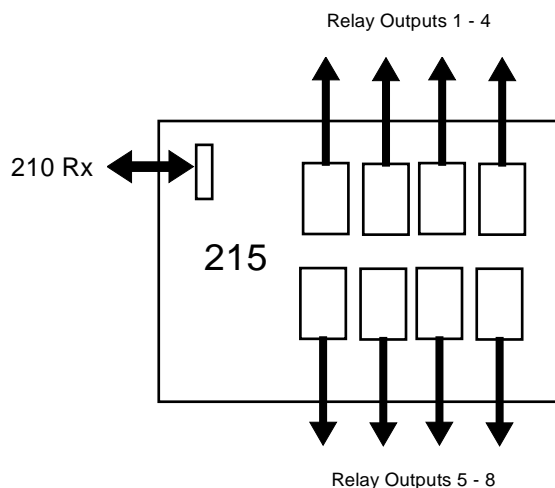

This DIN Rail module connects directly to any of the 210Rx output connectors and provides;

- 8 relay switches rated 230Vac at 3A

The only connections required are

- Connection to the 210 Receiver via the ribbon cable supplied.
- Connection to each relay via screw terminals provided.

The module requires no other connections as power is supplied from the 210Rx module.

### Technical Specifications

Dimensions: Within DIN Rail : 112 x 77 mm (PCB: 108 x 72mm)

Storage Temperature; -10 to +70° Celsius. Operating Temperature; 0 to +55° Celsius.

| Electrical Characteristics             | Min                           | Typical | Max | Units |
|--|-------------------------------|---------|-----|-------|
| Supply Voltage                         | From 210Rx module             |         |     |       |
| Relay output Rating<br>Type HRS1KH3-12 | Max rating is 3A/220VAC/30VDC |         |     |       |

### Part Numbering

| Part No | Description                                  |
|---------|--|
| 215R1   | Receiver Decoder Module with 8 relay outputs |

# 'DIN RAIL' RADIO REMOTE CONTROL

## '216' 4 Relay output Module

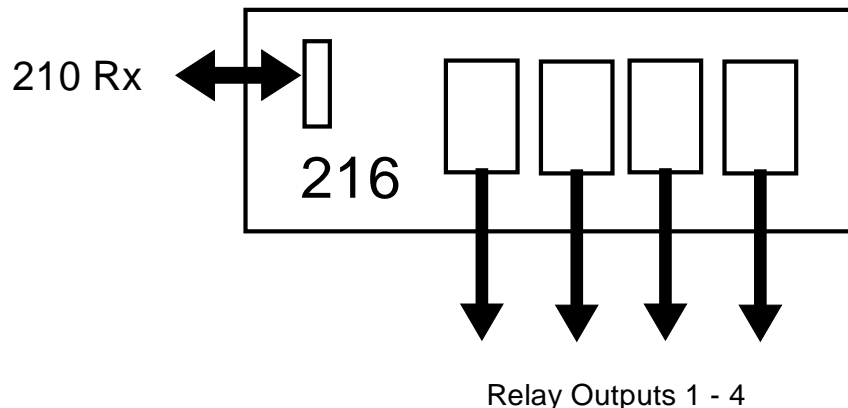

This DIN Rail module connects directly to the 210Rx and provides four relay outputs rated at 230Vac providing 12A peak and 5A continuous current rating. The only connections required are

- Connection to the 210 Receiver via the ribbon cable supplied.
- Connection to each relay output via screw terminals provided.

The module requires no other connections as power is supplied from the 210Rx module.

### Technical Specifications

Dimensions: Within DIN Rail : 135 x 77 mm (PCB: 132 x 72mm)

Storage Temperature; -10 to +70° Celsius. Operating Temperature; 0 to +55° Celsius.

| Electrical Characteristics                | Min               | Typical | Max | Units |
|---|-------------------|---------|-----|-------|
| Supply Voltage                            | From 210Rx module |         |     |       |
| Relay output Rating (type KB12) at 230Vac |                   | 5       | 12  | A     |

### Part Numbering

| Part No | Description                                  |
|---------|--|
| 216R1   | Receiver Decoder Module with 8 relay outputs |

# 'DIN RAIL' RADIO REMOTE CONTROL

## '217' Triac Dimming output Module

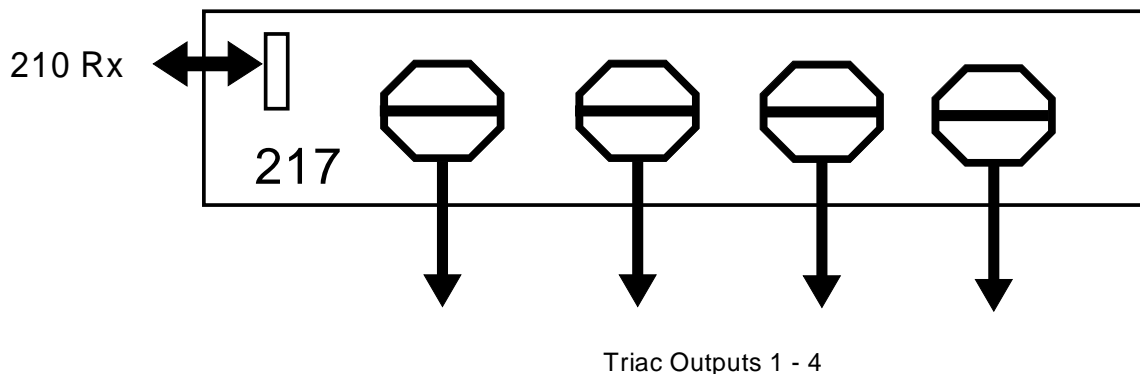

This DIN Rail module provides four dimming outputs rated 240 Vac at 2.5A continuous. Connection to the 210Rx module is by the lead supplied. This module may be connected to any of the 210 receiver's output plugs (marked as 1 – 4). However please note that the relevant 210 receiver outputs must be set to momentary operation without any time delay. Outputs may be controlled as latching, on / off or dimmed. The module requires no other connections as power is supplied from the 210Rx module

### Operation of the outputs.

To switch the output on or off, press the transmitter switch briefly. To dim the output, press and hold the transmitter switch. The output will dim up then down and continue this cycle until the user removes their finger from the switch.

### Warning!

The unit is designed to be a fixed installation, which may be connected to a mains supply. Before removing any cover ensure that the mains input supply is removed. Any installation and or operation of this product should only be carried out by a competent person or qualified electrician.

### Part Numbering

| Part No | Description   |
|---------|---|
| 217R1   | Phase Control Output Module; Dimming or Switched outputs 4 channels |

For more information or general enquiries, please contact

**R. F. Solutions Ltd.,**  
**Unit 21, Cliffe Industrial Estate,**  
**South Street,**  
**Lewes,**  
**E Sussex, BN8 6JL. England**

**Tel +44 (0)1273 898 000 Fax +44 (0)1273 480 661**

**Email sales@rfsolutions.co.uk http://www.rfsolutions.co.uk**

*RF Solutions is a member of the Low Power Radio Association*

All Trademarks acknowledged and remain the property of the respected owners

## X-ON Electronics

Largest Supplier of Electrical and Electronic Components

*Click to view similar products for [rf solutions manufacturer](#):*

Other Similar products are found below :

[FOBBER-8T2](#) [ZULU-868](#) [ANT-PCB4520-FL](#) [GAMMA-868-SO](#) [DB5XA](#) [ZULUEVAL-M](#) [DELTA-TRX8C1](#) [LAMBDA62C-9D](#)  
[LAMBDA80-24D](#) [ADP-SMAM-NF](#) [ADP-SMAFRP-SMAF](#) [GAMMA-868R-SO](#) [GAMMA-868R](#) [KAPPAM-ARD](#) [ICEPIC](#) [FLEXI-SMA-868](#)  
[FM-RTFQ2-433P](#) [DB756](#) [KAPPA-R868-SO](#) [ZETA-ARD-868](#) [ZULUEVAL-DONGLE](#) [ZETAPLUS-915-D](#) [TRAP-T1](#) [ANT-GROD8-NSMA](#)  
[ZPT-4RS](#) [HORNET200-TX1](#) [EZTEXT](#) [ICEPIC3-US](#) [I3-TRACER1](#) [ZULU-M-ARDUINO](#) [GAMMA-915R](#) [ANT-GSMSTUB4](#) [RFM68W-](#)  
[433-S2](#) [KAPPAT-ARD](#) [I3DBF77](#) [ALPHA-TRX433S](#) [ZETAPLUS-915-SO](#) [ANT-24G-DPL-SMA](#) [FOBLOQF-4S2](#) [ADP-SMAM-2SMAF](#)  
[CBA-SMAF-OP](#) [ANT-MCLING3-N](#) [RF600E](#) [HORNETPRO-8S3](#) [ZETA-868-SO](#) [CF-WU710NV2](#) [BRAVO-ARD](#) [LAMBDA62-8D](#) [110C2-](#)  
[433A](#) [ZULU2-M868-SO](#)