

Metallized polyester film capacitors

MKT 470

MKT RADIAL POTTED TYPE

PITCH 5 mm

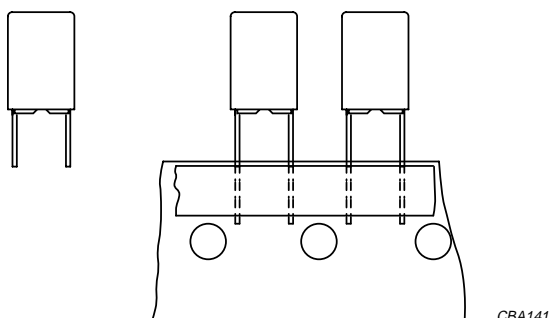

Fig.1 Simplified outlines.

FEATURES

- Low-inductive wound cell of metallized (PETP) film
- Potted with epoxy resin in a flame-retardant case
- Radial leads of solder-coated fecuma wire
- Withstands thermal shocks, oils, solvents and rinsing liquids
- Small stand-off pips to allow removal of solder flux
- Suitable for high density packaging.

QUICK REFERENCE DATA

DESCRIPTION	VALUE
Capacitance range (E12 series)	0.001 to 1.2 μ F
Capacitance tolerance	$\pm 10\%$; $\pm 5\%$
Rated (DC) voltage	63 V; 100 V; 250 V; 400 V
Climatic category	55/125/56
Maximum application temperature	125 °C
Rated temperature	85 °C
Tangent of loss angle at 100 kHz	150×10^{-4}
Reference specification	IEC 60384-2
Performance grade	grade 1 (long life)

APPLICATIONS

- Blocking and coupling of signals
- Bypass and energy reservoir
- Filter networks
- Pulse circuits
- Heavy duty and automotive
- Where high reliability is required.

DETAIL SPECIFICATION

For more detailed data and test requirements see "Type detail specification HQN-384-02/104".

Metallized polyester film capacitors

MKT 470

COMPOSITION OF CATALOGUE NUMBER

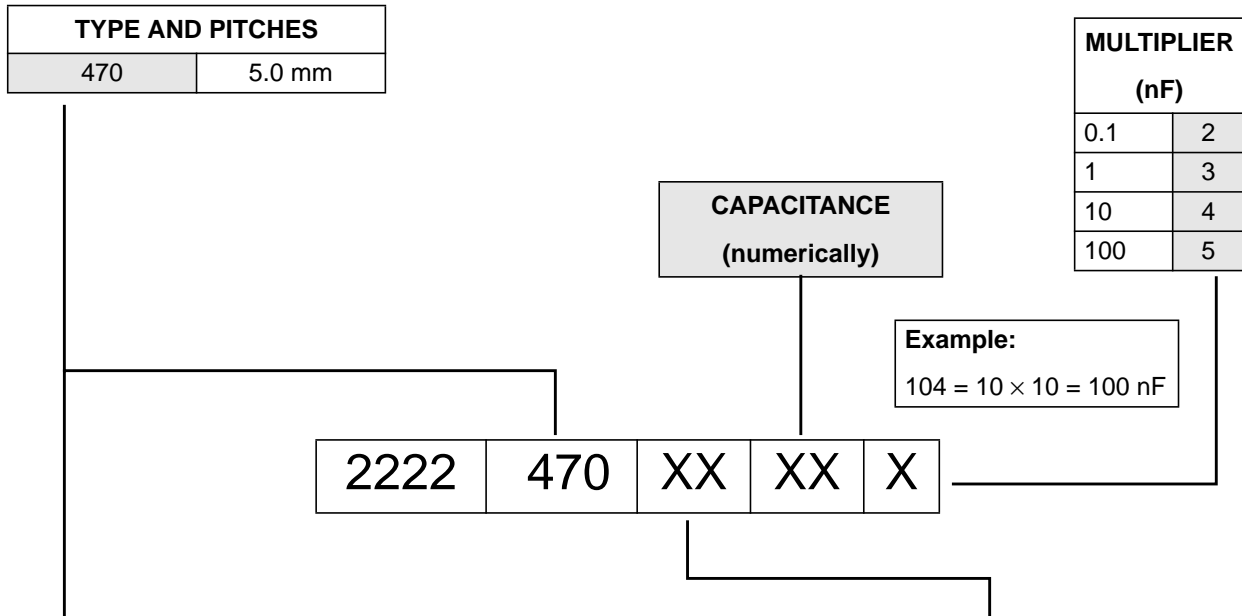

TYPE	PACKAGING	LEAD CONFIGURATION	C-TOL	63 V	100 V	250 V	400 V
470	ammopack	H = 18.5 mm; P ₀ = 12.7 mm	±10%	75	85	35	65
			±5%	76	86	36	66
	loose in box	lead length 4.0 mm	±10%	11	21	41	51
			±5%	12	22	42	52
		lead length 26.0 mm	±10%	15	25	45	55
			±5%	16	26	46	56
	taped on reel	H = 18.5 mm; P ₀ = 12.7 mm	±10%	18	28	48	58
			±5%	19	29	49	59

Metallized polyester film capacitors

MKT 470

MKT 470 GENERAL DATA

PITCH 5 mm

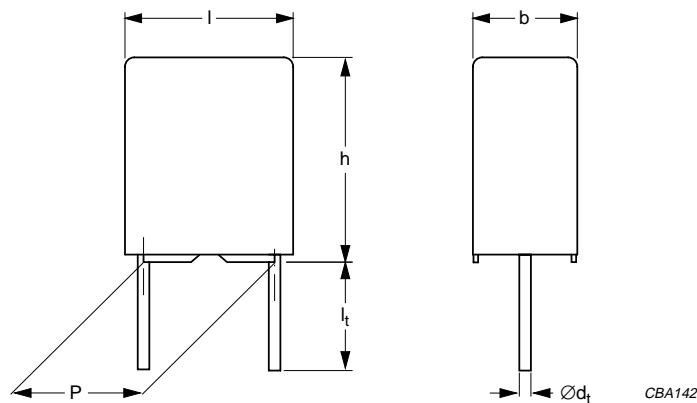

Fig.3 Outline.

Specific reference data for the 63 V DC capacitors

DESCRIPTION	VALUE		
	at 1 kHz	at 10 kHz	at 100 kHz
Tangent of loss angle: $C \leq 0.1 \mu\text{F}$ $0.1 \mu\text{F} < C \leq 0.47 \mu\text{F}$ $0.47 \mu\text{F} < C \leq 1.2 \mu\text{F}$	$\leq 60 \times 10^{-4}$	$\leq 120 \times 10^{-4}$	$\leq 200 \times 10^{-4}$
	$\leq 60 \times 10^{-4}$	$\leq 120 \times 10^{-4}$	$\leq 225 \times 10^{-4}$
	$\leq 60 \times 10^{-4}$	$\leq 120 \times 10^{-4}$	–
Rated voltage pulse slope $(dU/dt)_R$ at 63 V (DC)	100 V/ μs		
R between leads, for $C \leq 0.33 \mu\text{F}$ at 10 V; 1 minute	$>15000 \text{ M}\Omega$		
RC between leads, for $C > 0.33 \mu\text{F}$ at 10 V; 1 minute	$>5000 \text{ s}$		
R between interconnected leads and case (foil method)	$>30000 \text{ M}\Omega$		
Withstanding (DC) voltage (cut off current 10 mA); rise time 100 V/s	100 V; 1 minute		
Withstanding (DC) voltage between leads and case	200 V; 1 minute		

Available 63 V DC versions

PACKAGING ⁽¹⁾	DIMENSIONS	C-tol	FIRST 9 DIGITS OF CATALOGUE NUMBER	ORDERING
Ammopack	H = 18.5 mm; note 2	$\pm 10\%$	2222 470 75...	preferred
		$\pm 5\%$	2222 470 76...	preferred
Loose in box	$l_t = 4.0 +1.0/-0.5 \text{ mm}$	$\pm 10\%$	2222 470 11...	on request
		$\pm 5\%$	2222 470 12...	on request
	$l_t = 26.0 \pm 2.0 \text{ mm}$	$\pm 10\%$	2222 470 15...	on request
		$\pm 5\%$	2222 470 16...	on request
Taped on reel	H = 18.5 mm; note 2	$\pm 10\%$	2222 470 18...	on request
		$\pm 5\%$	2222 470 19...	on request

Notes

1. For SPQ refer to this handbook, chapter "Packaging information".
2. H = in-tape height; for detailed specifications refer to this handbook, chapter "Packaging information".

Metallized polyester film capacitors

MKT 470

 $U_{Rdc} = 63 \text{ V}$; $U_{Rac} = 40 \text{ V}$

C (μF)	DIMENSIONS $b \times h \times l$ (mm)	MASS (g)	CATALOGUE NUMBER	
			AMMOPACK	
			H = 18.5 mm	
			C-tol = $\pm 10\%$	C-tol = $\pm 5\%$
			catalogue number ⁽¹⁾	last 5 digits ⁽¹⁾
Pitch = $5.0 \pm 0.3 \text{ mm}$; $d_t = 0.50 \pm 0.05 \text{ mm}$				
0.068	2.5 × 6.5 × 7.2	0.25	2222 470 75683	.. 76683
0.082			2222 470 75823	.. 76823
0.1			2222 470 75104	.. 76104
0.12	3.5 × 8.0 × 7.2	0.35	2222 470 75124	.. 76124
0.15			2222 470 75154	.. 76154
0.18			2222 470 75184	.. 76184
0.22			2222 470 75224	.. 76224
0.27			2222 470 75274	.. 76274
0.33			2222 470 75334	.. 76334
0.39			2222 470 75394	.. 76394
0.47	4.5 × 9.0 × 7.2	0.45	2222 470 75474	.. 76474
0.56			2222 470 75564	.. 76564
0.68			2222 470 75684	.. 76684
0.82	6.0 × 11.0 × 7.2	0.60	2222 470 75824	.. 76824
1			2222 470 75105	.. 76105
1.2			2222 470 75125	.. 76125

Note

1. The shading indicates preferred types.

Metallized polyester film capacitors

MKT 470

MKT 470 GENERAL DATA

PITCH 5 mm

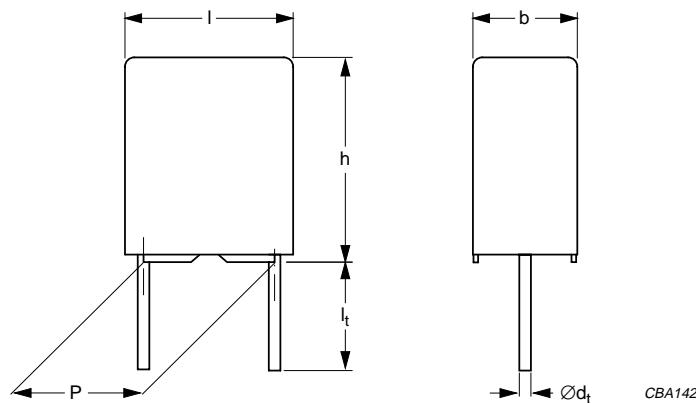

Fig.4 Outline.

Specific reference data for the 100 V DC capacitors

DESCRIPTION	VALUE		
	at 1 kHz	at 10 kHz	at 100 kHz
Tangent of loss angle: C ≤ 0.1 μF 0.1 μF < C ≤ 0.47 μF	≤60 × 10 ⁻⁴ ≤60 × 10 ⁻⁴	≤120 × 10 ⁻⁴ ≤120 × 10 ⁻⁴	≤200 × 10 ⁻⁴ ≤225 × 10 ⁻⁴
Rated voltage pulse slope (dU/dt) _R at 100 V (DC)	160 V/μs		
R between leads, for C ≤ 0.33 μF at 100 V; 1 minute	>15000 MΩ		
RC between leads, for C > 0.33 μF at 100 V; 1 minute	>5000 s		
R between interconnected leads and case (foil method)	>30000 MΩ		
Withstanding (DC) voltage (cut off current 10 mA); rise time 100 V/s	160 V; 1 minute		
Withstanding (DC) voltage between leads and case	200 V; 1 minute		

Available 100 V DC versions

PACKAGING ⁽¹⁾	DIMENSIONS	C-tol	FIRST 9 DIGITS OF CATALOGUE NUMBER	ORDERING
Ammopack	H = 18.5 mm; note 2	±10%	2222 470 85...	preferred
		±5%	2222 470 86...	preferred
Loose in box	l _t = 4.0 +1.0/-0.5 mm	±10%	2222 470 21...	on request
		±5%	2222 470 22...	on request
	l _t = 26.0 ±2.0 mm	±10%	2222 470 25...	on request
		±5%	2222 470 26...	on request
Taped on reel	H = 18.5 mm; note 2	±10%	2222 470 28...	on request
		±5%	2222 470 29...	on request

Notes

1. For SPQ refer to this handbook, chapter "Packaging information".
2. H = in-tape height; for detailed specifications refer to this handbook, chapter "Packaging information".

Metallized polyester film capacitors

MKT 470

 $U_{Rdc} = 100 \text{ V}$; $U_{Rac} = 63 \text{ V}$

C (μF)	DIMENSIONS $b \times h \times l$ (mm)	MASS (g)	CATALOGUE NUMBER	
			AMMOPACK	
			H = 18.5 mm	
			C-tol = $\pm 10\%$	C-tol = $\pm 5\%$
			catalogue number ⁽¹⁾	last 5 digits ⁽¹⁾
Pitch = $5.0 \pm 0.3 \text{ mm}$; $d_t = 0.50 \pm 0.05 \text{ mm}$				
0.022	2.5 × 6.5 × 7.2	0.25	2222 470 85 223	.. 86 223
0.027			2222 470 85 273	.. 86 273
0.033			2222 470 85 333	.. 86 333
0.039			2222 470 85 393	.. 86 393
0.047			2222 470 85 473	.. 86 473
0.056			2222 470 85 563	.. 86 563
0.068	3.5 × 8.0 × 7.2	0.35	2222 470 85 683	.. 86 683
0.082			2222 470 85 823	.. 86 823
0.1			2222 470 85 104	.. 86 104
0.12			2222 470 85 124	.. 86 124
0.15	4.5 × 9.0 × 7.2	0.45	2222 470 85 154	.. 86 154
0.18			2222 470 85 184	.. 86 184
0.22			2222 470 85 224	.. 86 224
0.27	6.0 × 11.0 × 7.2	0.65	2222 470 85 274	.. 86 274
0.33			2222 470 85 334	.. 86 334
0.39			2222 470 85 394	.. 86 394
0.47			2222 470 85 474	.. 86 474

Note

1. The shading indicates preferred types.

Metallized polyester film capacitors

MKT 470

MKT 470 GENERAL DATA

PITCH 5 mm

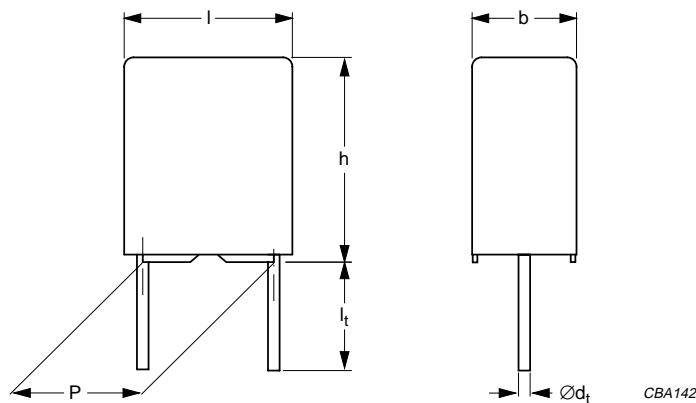

Fig.5 Outline.

Specific reference data for the 250 V DC capacitors

DESCRIPTION	VALUE			
	at 1 kHz	at 10 kHz	at 100 kHz	at 1 MHz
Tangent of loss angle: $C \leq 0.01 \mu\text{F}$ $0.01 \mu\text{F} < C \leq 0.1 \mu\text{F}$ $0.1 \mu\text{F} < C \leq 0.12 \mu\text{F}$	$\leq 60 \times 10^{-4}$	$\leq 120 \times 10^{-4}$	$\leq 200 \times 10^{-4}$	$\leq 250 \times 10^{-4}$
Rated voltage pulse slope $(dU/dt)_R$ at 250 V (DC)	400 V/ μs			
R between leads at 100 V; 1 minute	$>15000 \text{ M}\Omega$			
R between interconnected leads and case (foil method)	$>30000 \text{ M}\Omega$			
Withstanding (DC) voltage (cut off current 10 mA); rise time 100 V/s	400 V; 1 minute			
Withstanding (DC) voltage between leads and case	500 V; 1 minute			

Available 250 V DC versions

PACKAGING ⁽¹⁾	DIMENSIONS	C-tol	FIRST 9 DIGITS OF CATALOGUE NUMBER	ORDERING
Ammopack	H = 18.5 mm; note 2	$\pm 10\%$	2222 470 35...	preferred
		$\pm 5\%$	2222 470 36...	preferred
Loose in box	$l_t = 4.0 +1.0/-0.5 \text{ mm}$	$\pm 10\%$	2222 470 41...	on request
		$\pm 5\%$	2222 470 42...	on request
	$l_t = 26.0 \pm 2.0 \text{ mm}$	$\pm 10\%$	2222 470 45...	on request
		$\pm 5\%$	2222 470 46...	on request
Taped on reel	H = 18.5 mm; note 2	$\pm 10\%$	2222 470 48...	on request
		$\pm 5\%$	2222 470 49...	on request

Notes

- For SPQ refer to this handbook, chapter "Packaging information".
- H = in-tape height; for detailed specifications refer to this handbook, chapter "Packaging information".

Metallized polyester film capacitors

MKT 470

 $U_{Rdc} = 250 \text{ V}$; $U_{Rac} = 160 \text{ V}$

C (μF)	DIMENSIONS $b \times h \times l$ (mm)	MASS (g)	CATALOGUE NUMBER	
			AMMOPACK	
			H = 18.5 mm	
			C-tol = $\pm 10\%$	C-tol = $\pm 5\%$
			catalogue number ⁽¹⁾	last 5 digits ⁽¹⁾
Pitch = $5.0 \pm 0.3 \text{ mm}$; $d_t = 0.50 \pm 0.05 \text{ mm}$				
0.01	2.5 × 6.5 × 7.2	0.25	2222 470 351 03	.. 361 03
0.012			2222 470 351 23	.. 361 23
0.015			2222 470 351 53	.. 361 53
0.018			2222 470 351 83	.. 361 83
0.022	3.5 × 8.0 × 7.2	0.35	2222 470 352 23	.. 362 23
0.027			2222 470 352 73	.. 362 73
0.033			2222 470 353 33	.. 363 33
0.039			2222 470 353 93	.. 363 93
0.047	4.5 × 9.0 × 7.2	0.45	2222 470 354 73	.. 364 73
0.056			2222 470 355 63	.. 365 63
0.068			2222 470 356 83	.. 366 83
0.082	6.0 × 11.0 × 7.2	0.60	2222 470 358 23	.. 368 23
0.1			2222 470 351 04	.. 361 04
0.12			2222 470 351 24	.. 361 24

Note

1. The shading indicates preferred types.

Metallized polyester film capacitors

MKT 470

MKT 470 GENERAL DATA

PITCH 5 mm

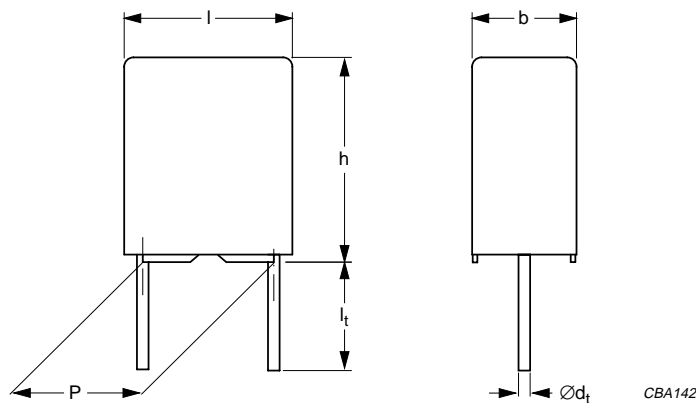

Fig.6 Outline.

Specific reference data for the 400 V DC capacitors

DESCRIPTION	VALUE			
	at 1 kHz	at 10 kHz	at 100 kHz	at 1 MHz
Tangent of loss angle: C ≤ 0.01 μF 0.01 μF < C ≤ 0.047 μF	≤ 60 × 10 ⁻⁴ ≤ 60 × 10 ⁻⁴	≤ 120 × 10 ⁻⁴ ≤ 120 × 10 ⁻⁴	≤ 200 × 10 ⁻⁴ ≤ 200 × 10 ⁻⁴	≤ 250 × 10 ⁻⁴ -
Rated voltage pulse slope (dU/dt) _R at 400 V (DC)	800 V/μs			
R between leads at 100 V; 1 minute	>15000 MΩ			
R between interconnected leads and case (foil method)	>30000 MΩ			
Withstanding (DC) voltage (cut off current 10 mA); rise time 100 V/s	640 V; 1 minute			
Withstanding (DC) voltage between leads and case	800 V; 1 minute			

Available 400 V DC versions

PACKAGING ⁽¹⁾	DIMENSIONS	C-tol	FIRST 9 DIGITS OF CATALOGUE NUMBER	ORDERING
Ammopack	H = 18.5 mm; note 2	±10%	2222 470 65...	preferred
		±5%	2222 470 66...	preferred
Loose in box	l _t = 4.0 +1.0/-0.5 mm	±10%	2222 470 51...	on request
		±5%	2222 470 52...	on request
	l _t = 26.0 ±2.0 mm	±10%	2222 470 55...	on request
		±5%	2222 470 56...	on request
Taped on reel	H = 18.5 mm; note 2	±10%	2222 470 58...	on request
		±5%	2222 470 59...	on request

Notes

1. For SPQ refer to this handbook, chapter "Packaging information".
2. H = in-tape height; for detailed specifications refer to this handbook, chapter "Packaging information".

Metallized polyester film capacitors

MKT 470

 $U_{Rdc} = 400 \text{ V}$; $U_{Rac} = 220 \text{ V}$

C (μF)	DIMENSIONS $b \times h \times l$ (mm)	MASS (g)	CATALOGUE NUMBER	
			AMMOPACK	
			H = 18.5 mm	
			C-tol = $\pm 10\%$	C-tol = $\pm 5\%$
			catalogue number ⁽¹⁾	last 5 digits ⁽¹⁾
Pitch = $5.0 \pm 0.3 \text{ mm}$; $d_t = 0.50 \pm 0.05 \text{ mm}$				
0.001	2.5 × 6.5 × 7.2	0.25	2222 470 65102	.. 66102
0.0012			2222 470 65122	.. 66122
0.0015			2222 470 65152	.. 66152
0.0018			2222 470 65182	.. 66182
0.0022			2222 470 65222	.. 66222
0.0027			2222 470 65272	.. 66272
0.0033			2222 470 65332	.. 66332
0.0039			2222 470 65392	.. 66392
0.0047			2222 470 65472	.. 66472
0.0056			2222 470 65562	.. 66562
0.0068			2222 470 65682	.. 66682
0.0082			2222 470 65822	.. 66822
0.01			3.5 × 8.0 × 7.2	0.35
0.012	2222 470 65123	.. 66123		
0.015	2222 470 65153	.. 66153		
0.018	4.5 × 9.0 × 7.2	0.45	2222 470 65183	.. 66183
0.022			2222 470 65223	.. 66223
0.027			2222 470 65273	.. 66273
0.033	6.0 × 11.0 × 7.2	0.60	2222 470 65333	.. 66333
0.039			2222 470 65393	.. 66393
0.047			2222 470 65473	.. 66473

Note

1. The shading indicates preferred types.

Metallized polyester film capacitors

MKT 470

CONSTRUCTION

Description

- Low-inductive wound cell of metallized polyethylene terephthalate (PETP) film, potted with epoxy resin in a flame-retardant case
- Radial leads, copper clad iron wire
- Small stand-off pips allow removal of solder flux etc. during cleaning of the printed-circuit board.

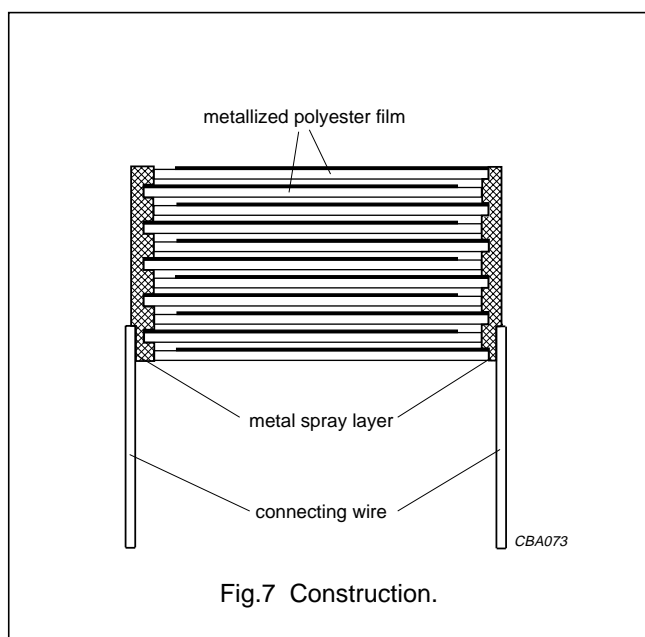

Fig.7 Construction.

Mounting

NORMAL USE

The capacitors are designed for mounting on printed-circuit boards. The capacitors packed in bandoliers are designed for mounting on printed-circuit boards by automatic insertion machines. For detailed tape specifications refer to this handbook, chapter "Packaging information".

SPECIFIC METHOD OF MOUNTING TO WITHSTAND VIBRATION AND SHOCK TEST

In order to withstand vibration and shock tests, it must be ensured that the stand-off pips are in good contact with the printed-circuit board.

SPACE REQUIREMENTS ON PRINTED-CIRCUIT BOARD

The maximum length and width of film capacitors is shown in Fig.8:

- Eccentricity see Fig.8. The maximum eccentricity is smaller than or equal to the wire diameter of the product concerned.
- Product height with seating plane as given by "IEC 60717" as reference: $h_{max} \leq h + 0.3 \text{ mm}$.

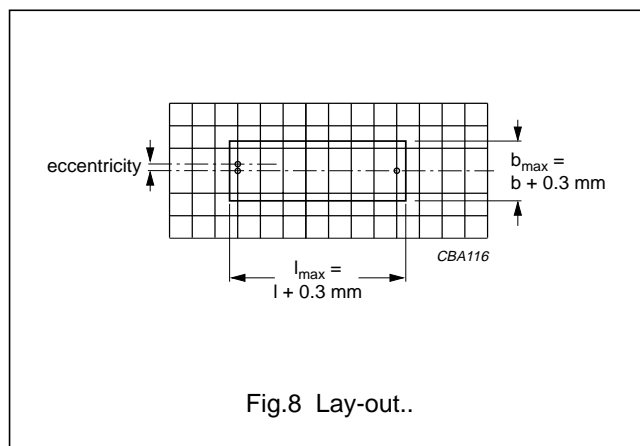

Fig.8 Lay-out..

Storage temperature

- Storage temperature: $T_{stg} = -25 \text{ to } +40 \text{ }^\circ\text{C}$ with RH maximum 80% without condensation.

RATINGS AND CHARACTERISTICS REFERENCE CONDITIONS

Unless otherwise specified, all electrical values apply to an ambient free air temperature of $23 \pm 1 \text{ }^\circ\text{C}$, an atmospheric pressure of 86 to 106 kPa and a relative humidity of $50 \pm 2\%$.

For reference testing, a conditioning period shall be applied over 96 ± 4 hours by heating the products in a circulating air oven at the rated temperature and a relative humidity not exceeding 20%.

Metallized polyester film capacitors

MKT 470

CHARACTERISTICS

Capacitance

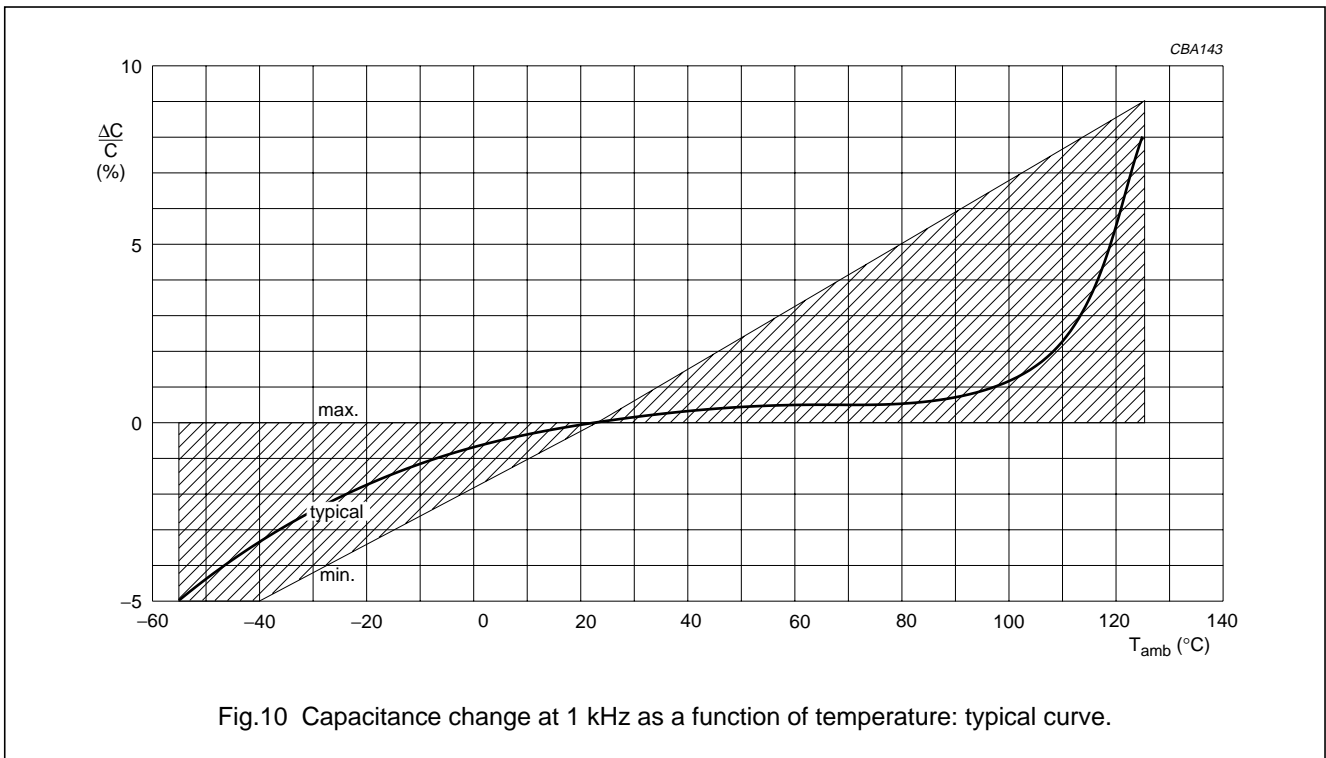
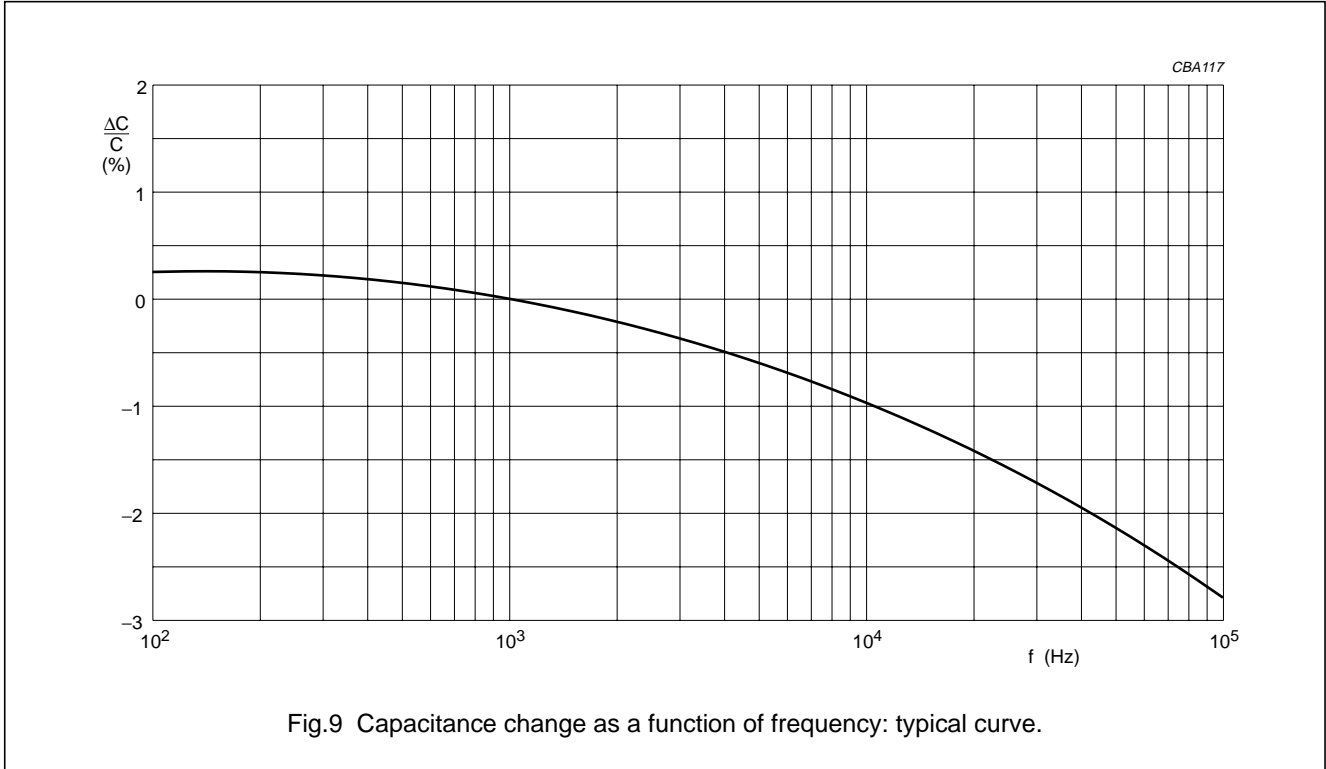

Metallized polyester film capacitors

MKT 470

Impedance

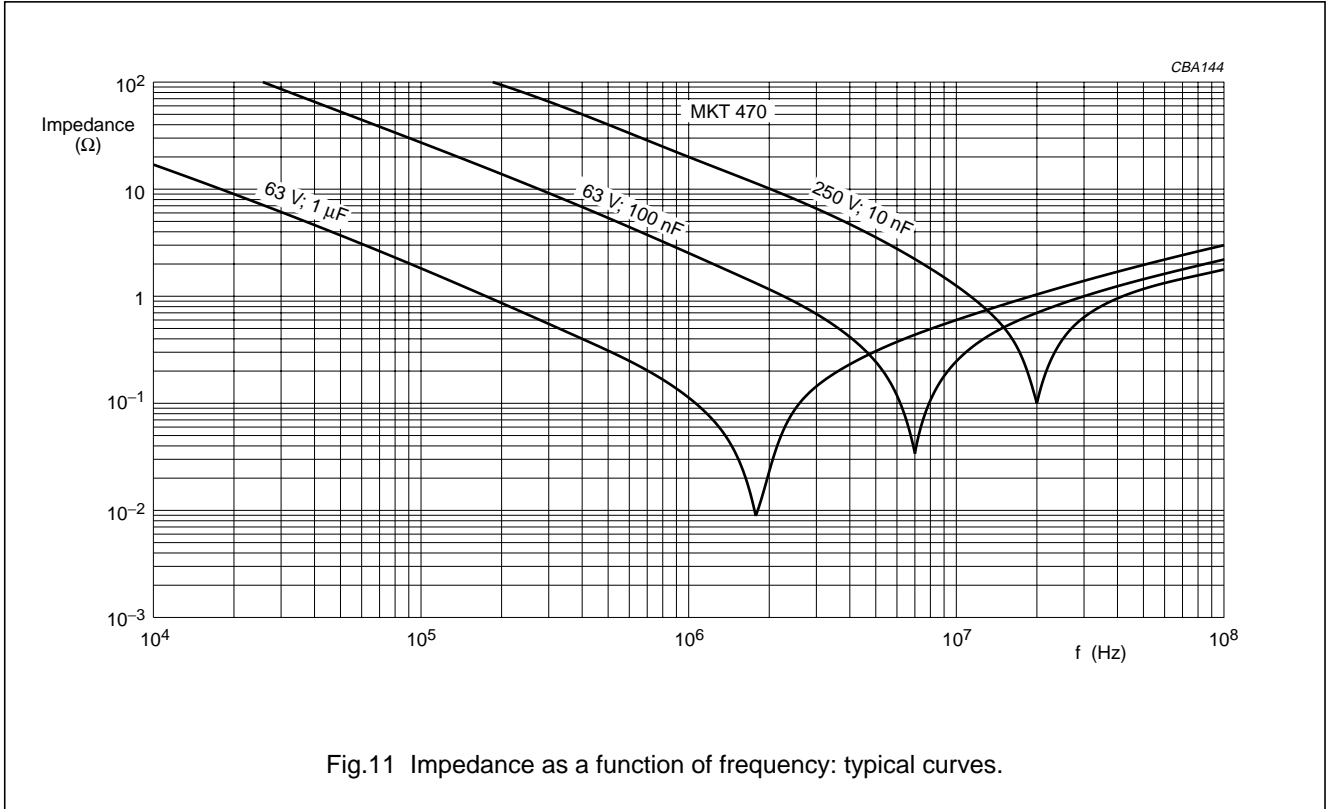

Maximum DC and AC voltage as a function of temperature

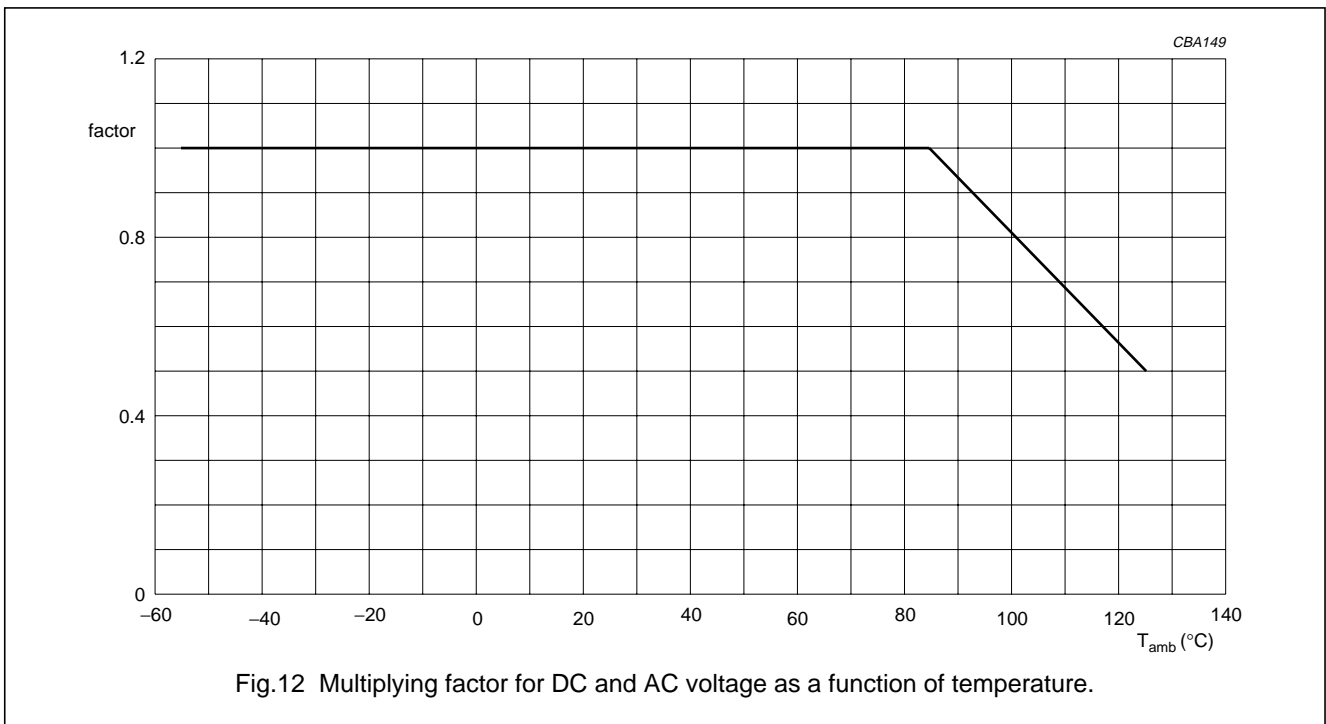

Metallized polyester film capacitors

MKT 470

Maximum RMS voltage (sinewave) as a function of frequency

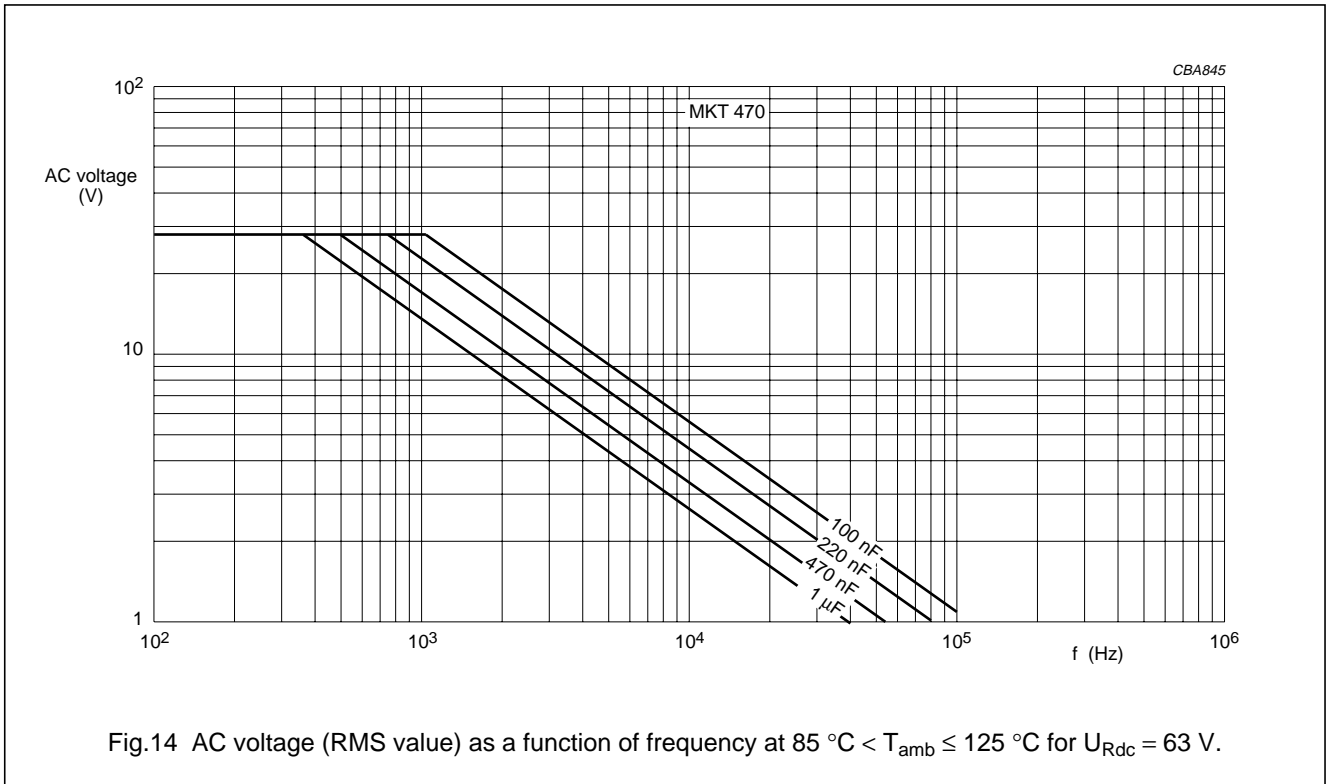
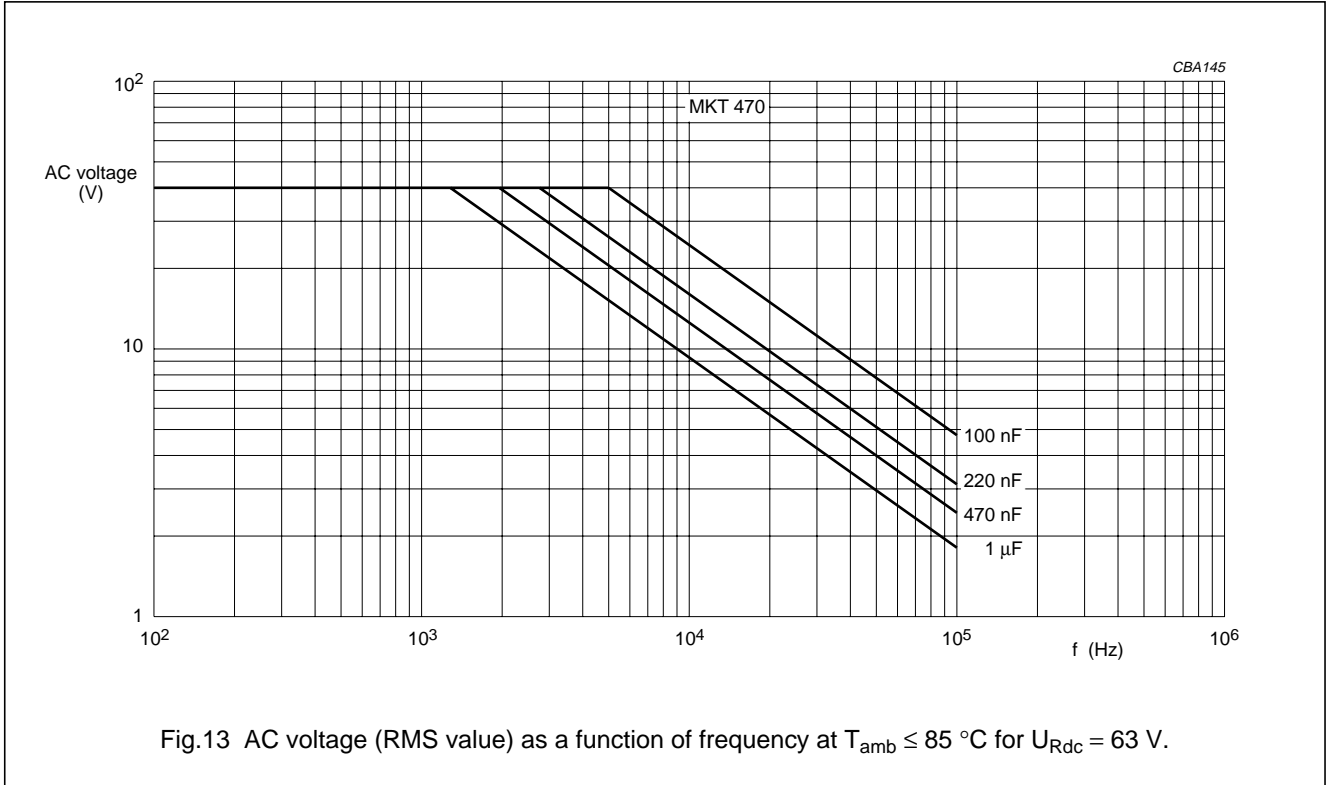

Metallized polyester film capacitors

MKT 470

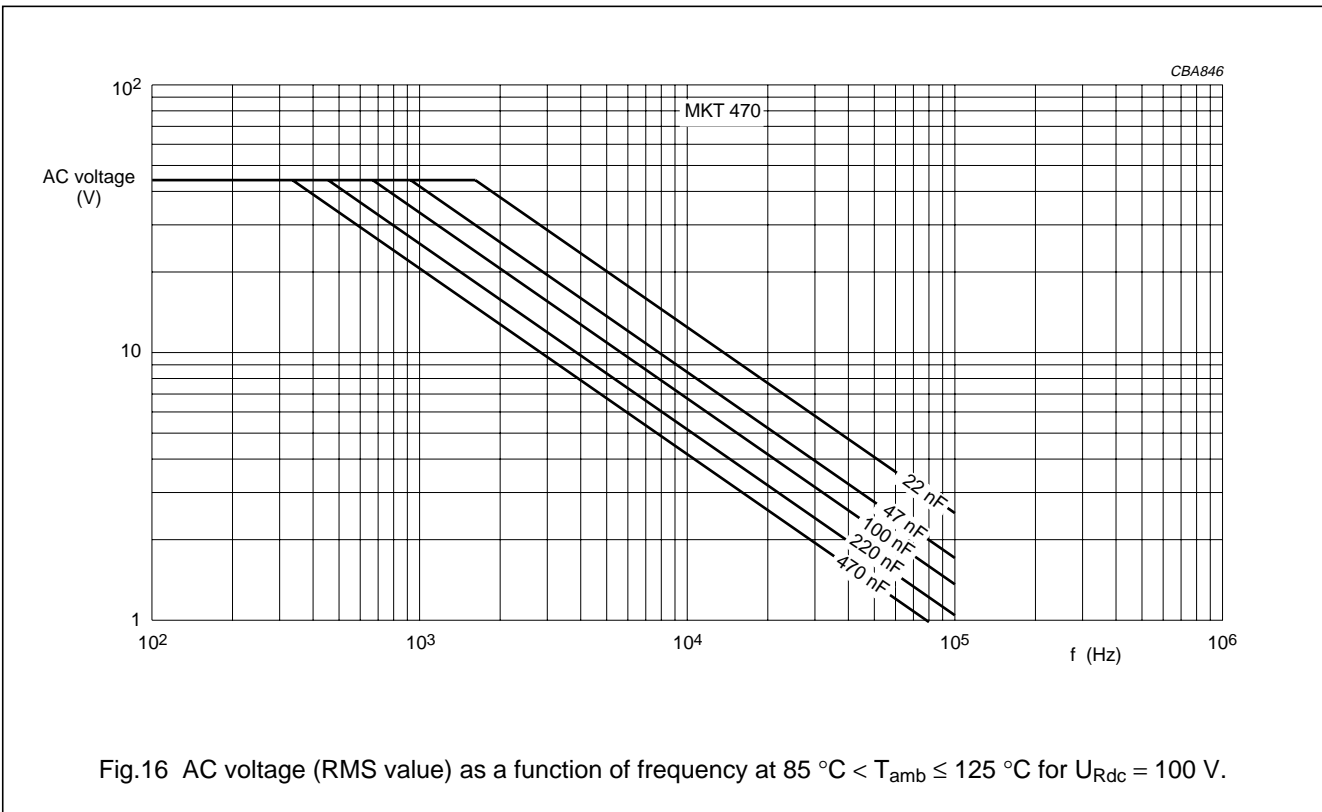
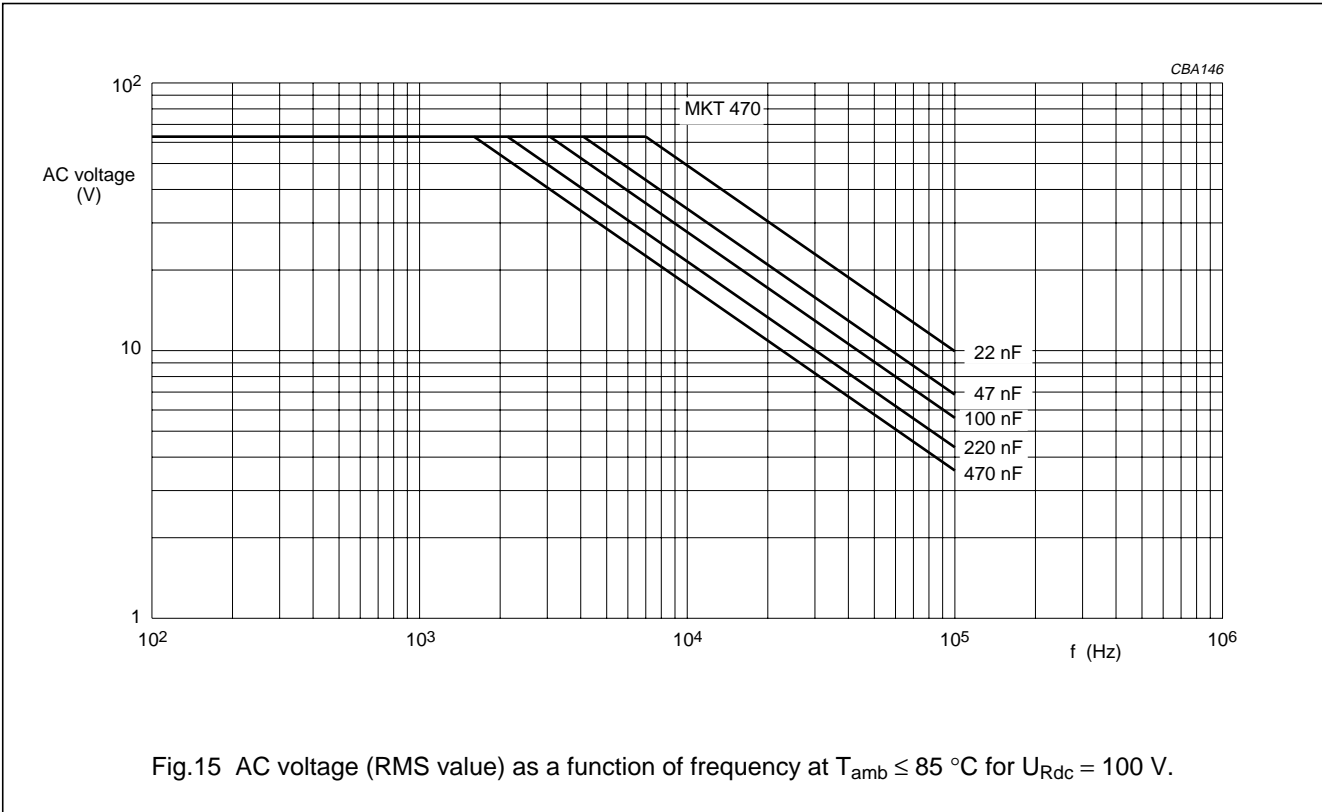

Metallized polyester film capacitors

MKT 470

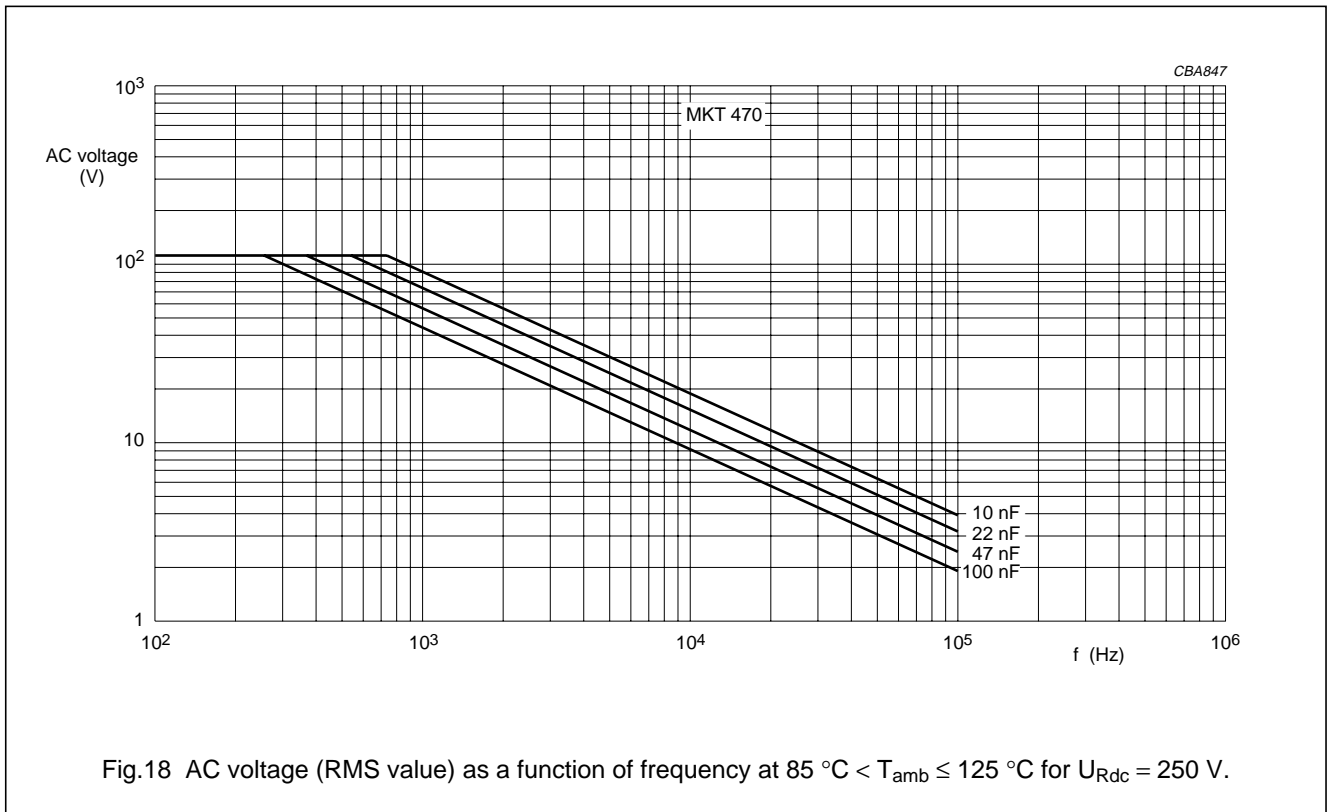
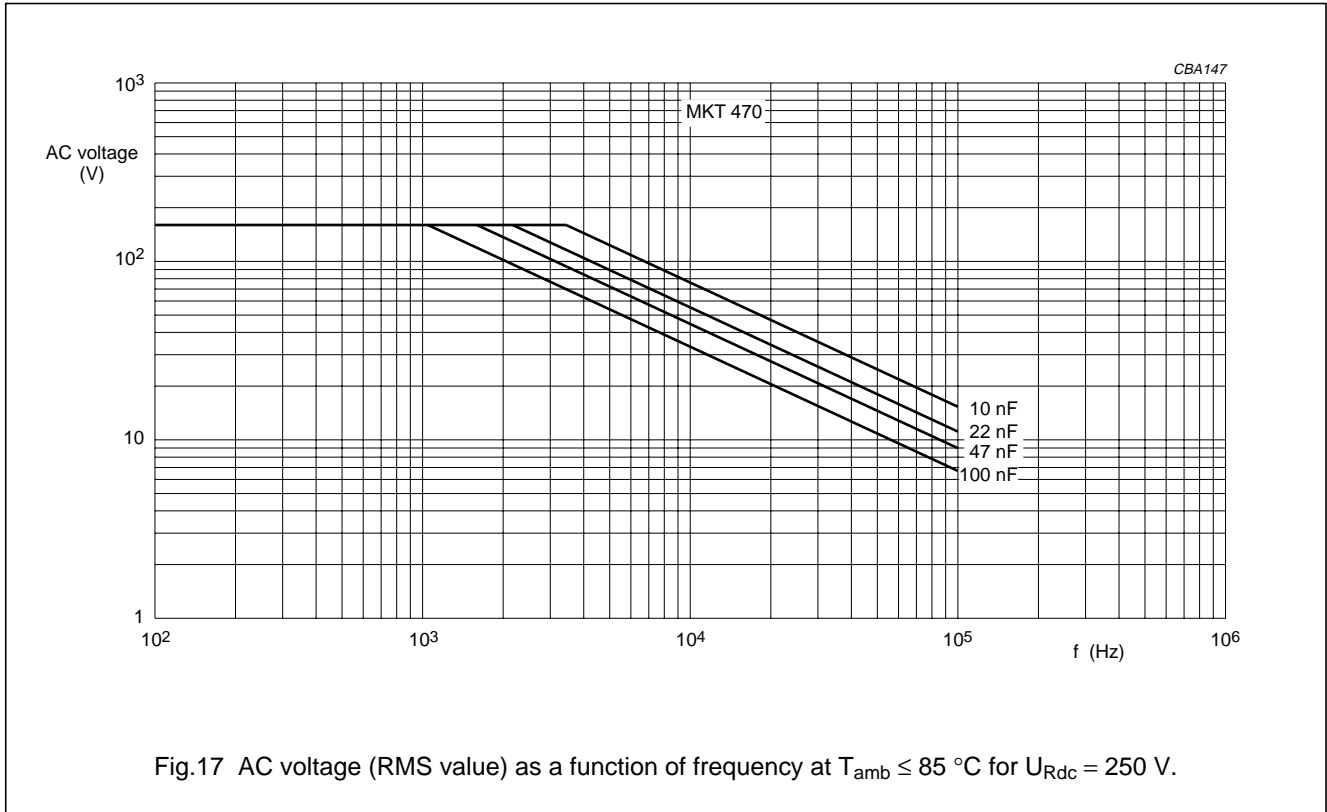

Metallized polyester film capacitors

MKT 470

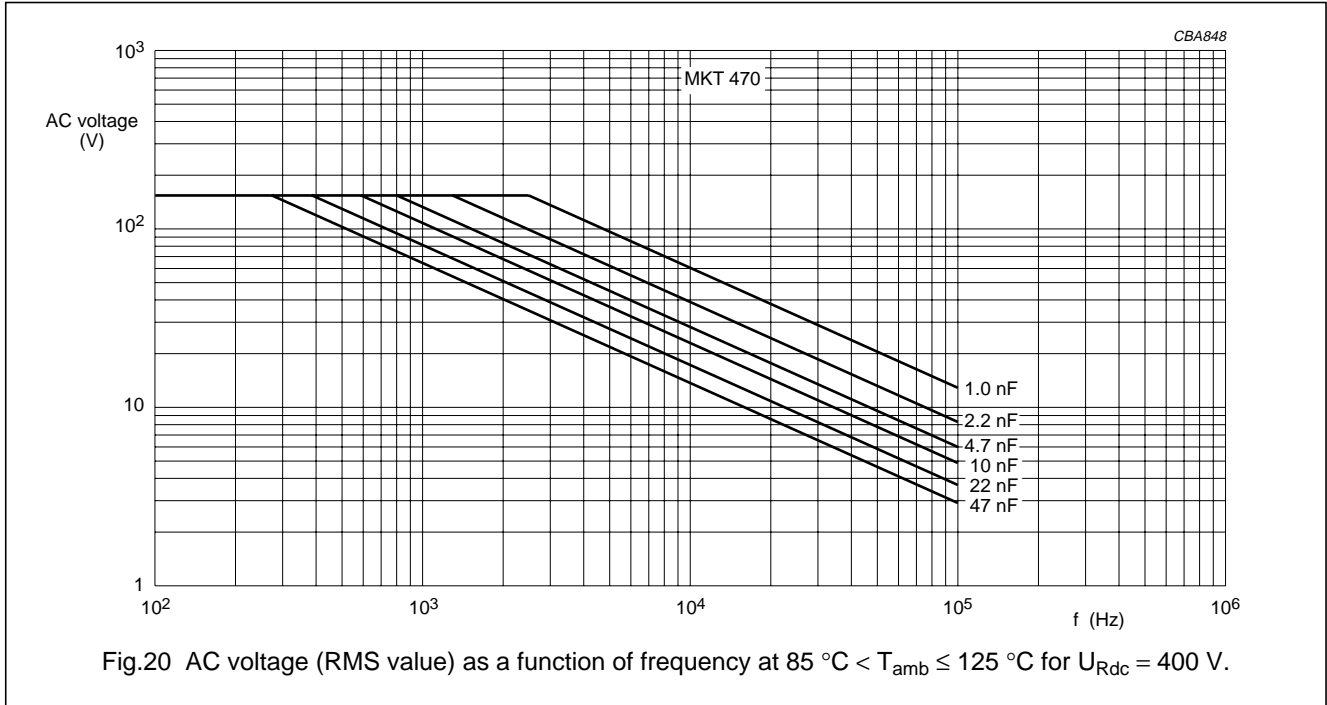
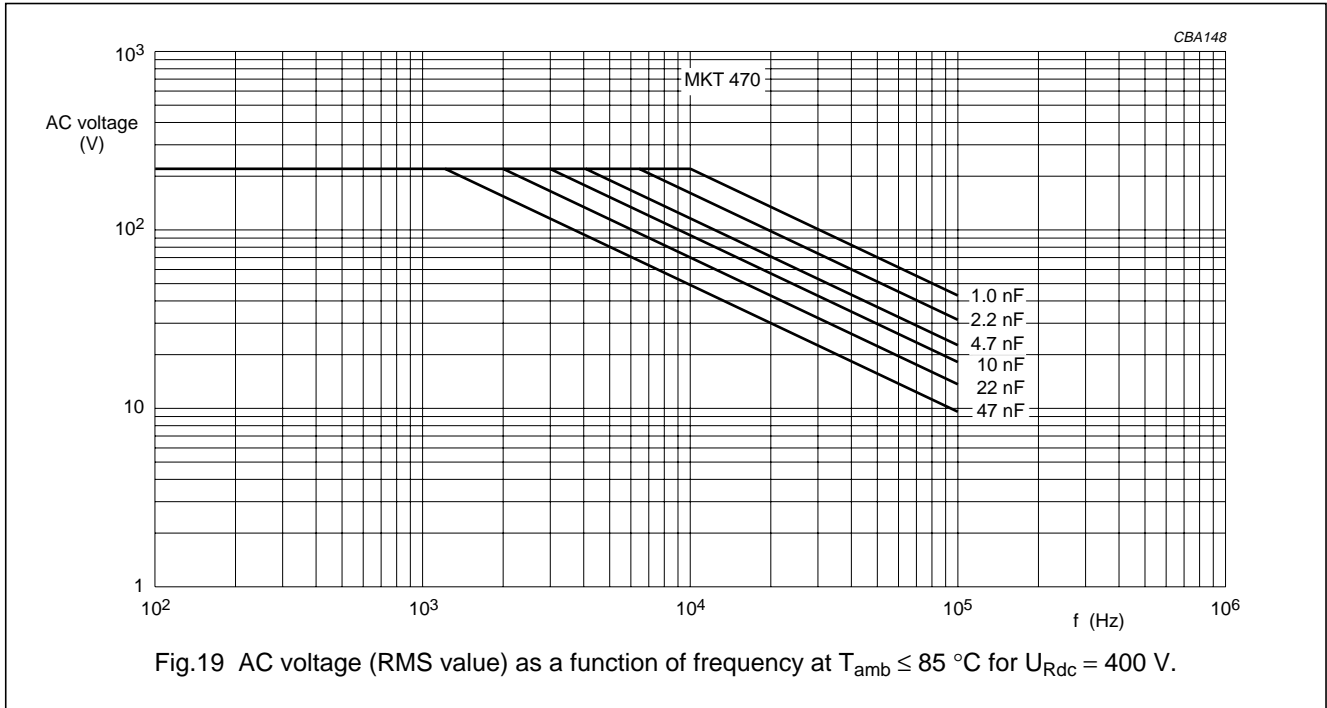

Maximum RMS current (sinewave) as a function of frequency

The maximum RMS current is defined by $I_{ac} = \omega \times C \times U_{ac}$.

U_{ac} is the maximum AC voltage depending on the ambient temperature in Figs 13 to 20.

Metallized polyester film capacitors

MKT 470

Tangent of loss angle

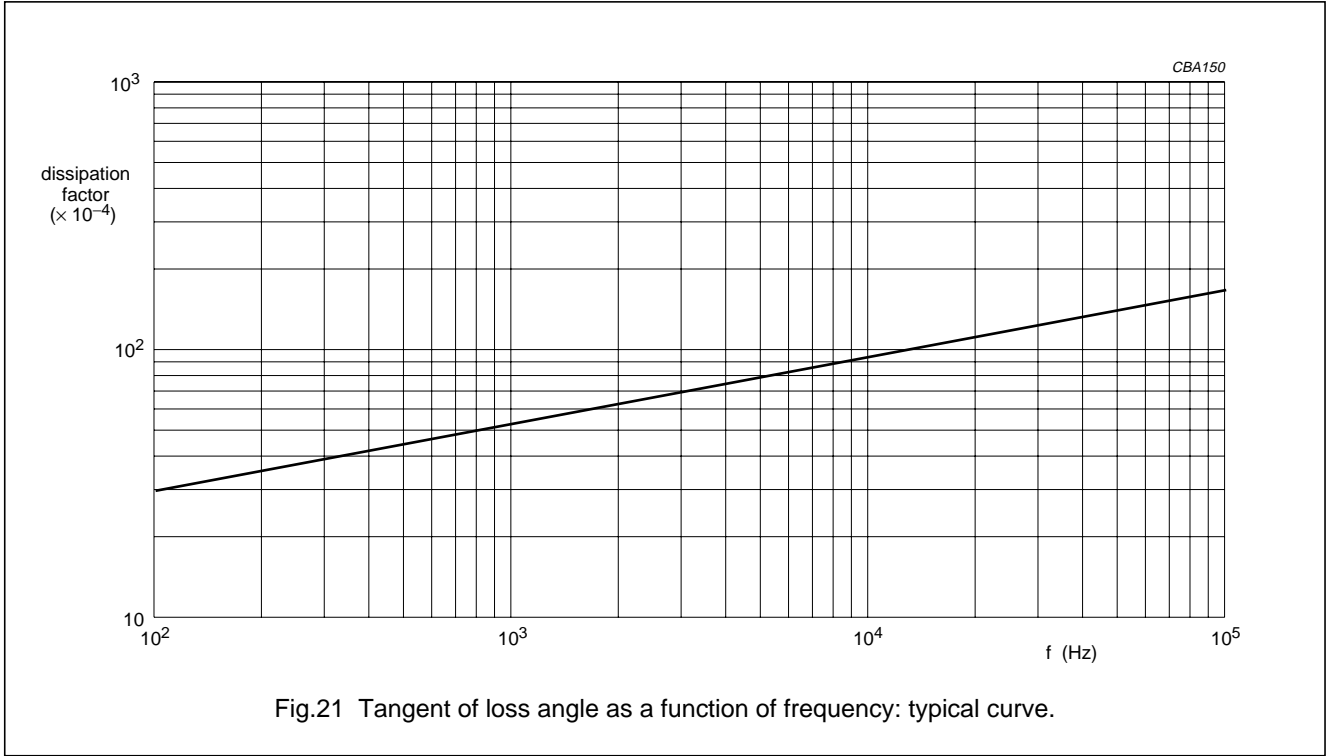

Insulation resistance

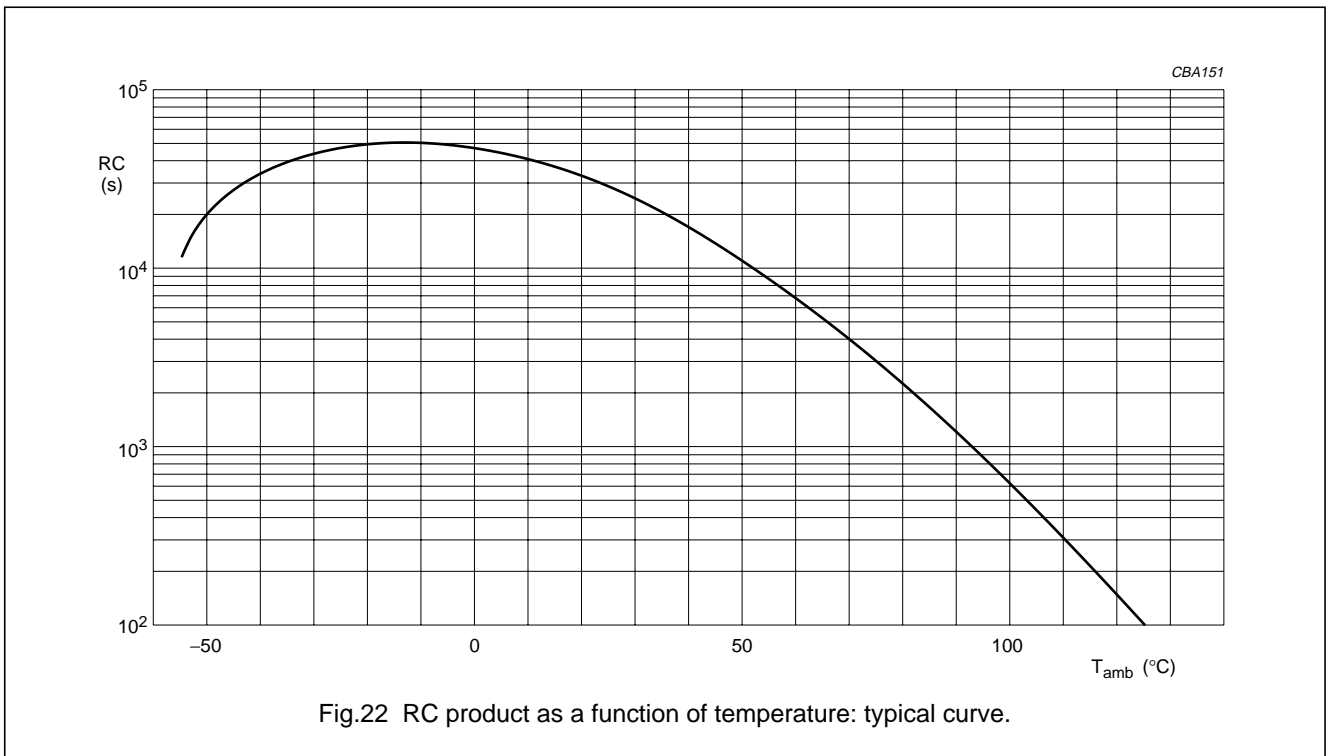

Metallized polyester film capacitors

MKT 470

Maximum allowed component temperature rise (ΔT) as a function of the ambient temperature (T_{amb})

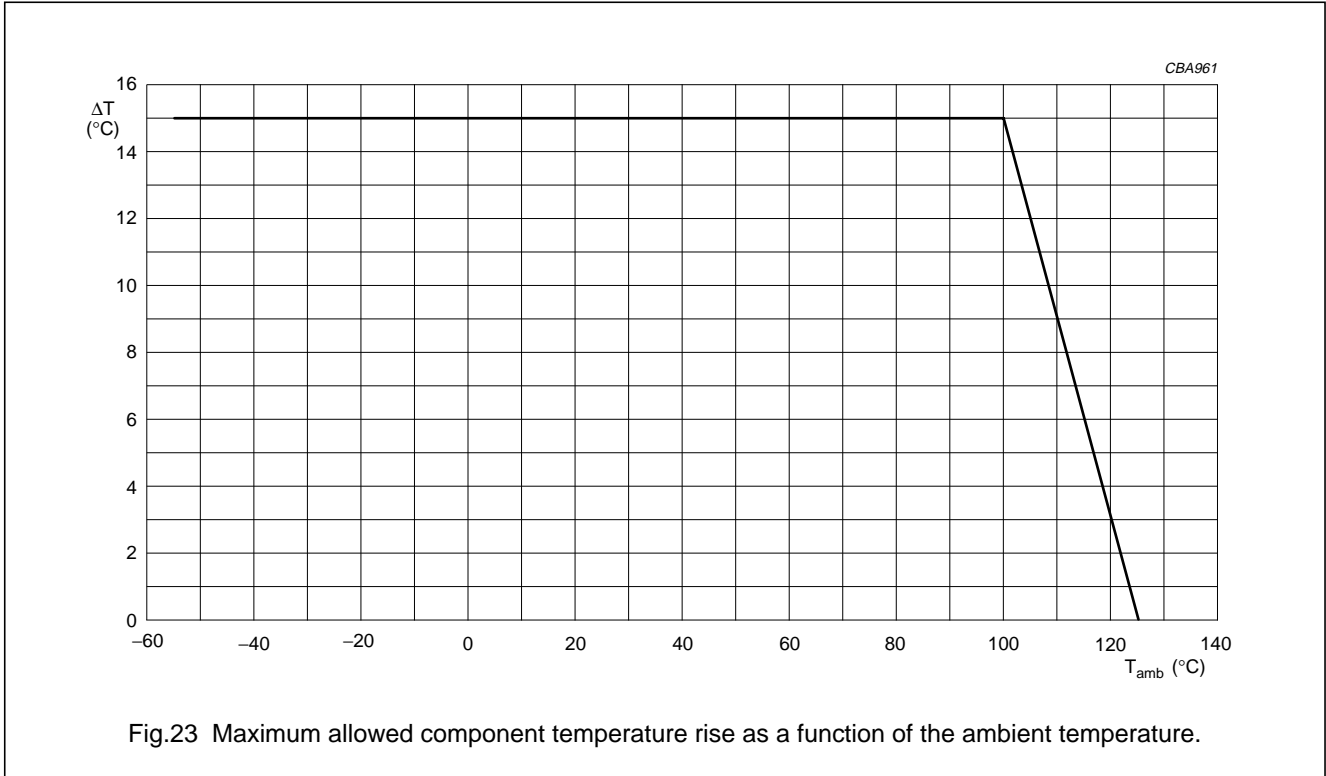

Fig.23 Maximum allowed component temperature rise as a function of the ambient temperature.

Heat conductivity (G) as a function of pitch and capacitor body thickness in mW/°C

Table 1 Heat conductivity

b_{max} (mm)	PITCH (mm)
2.5	2.5
3.5	3.0
4.5	4.0
6.0	5.5

Power dissipation and maximum component temperature rise

The power dissipation must be limited in order not to exceed the maximum allowed component temperature rise as a function of the free air ambient temperature.

Power dissipation can be calculated in accordance with chapter "Introduction", section "Maximum power dissipation".

The component temperature rise (ΔT) can be measured (see section "Measuring the component temperature" for more details) or calculated by $\Delta T = P/G$:

- ΔT = component temperature rise (°C).
- P = power dissipation of the component (mW).
- G = heat conductivity of the component (mW/°C).

Metallized polyester film capacitors

MKT 470

Measuring the component temperature

A thermocouple must be attached to the capacitor body; see Fig.24.

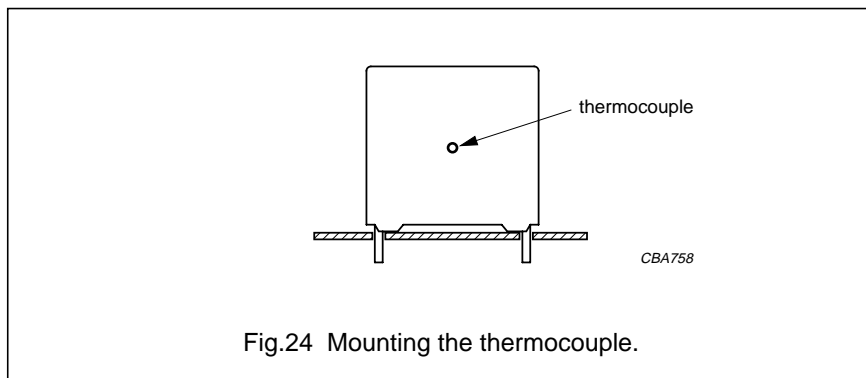

Fig.24 Mounting the thermocouple.

The temperature is measured in unloaded (T_{amb}) and maximum loaded condition (T_c).

The temperature rise is given by: $\Delta T = T_c - T_{amb}$.

To avoid radiation or convection, the capacitor should be tested in a wind-free box.

Metallized polyester film capacitors

MKT 470

Application note and limiting conditions

These capacitors are not suitable for mains applications as across-the-line capacitors without additional protection; see below. These mains applications are strictly regulated by safety standards and therefore electromagnetic interference suppression capacitors conforming to the standards must be used.

To select the capacitor for a certain application, the following conditions must be checked:

1. The peak voltage (U_p) shall not be greater than the rated DC voltage (U_{Rdc}).
2. The peak-to-peak voltage (U_{p-p}) shall not be greater than the maximum U_{p-p} to avoid the ionisation inception level.
3. The voltage pulse slope (dU/dt) shall not exceed the rated voltage pulse slope in an RC-circuit at rated voltage and without ringing. If the pulse voltage is lower than the rated DC voltage, the rated voltage pulse slope may be multiplied by U_{Rdc} and divided by the applied voltage.

For all other pulses following equation must be fulfilled:

$$2 \times \int_0^T \left(\frac{dU}{dt} \right)^2 \times dt < U_{Rdc} \times \left(\frac{dU}{dt} \right)_{rated}$$

T is the pulse duration.

The rated voltage pulse slope is valid for ambient temperatures up to 85 °C. For higher temperatures a derating factor of 3% per K shall be applied.

4. The maximum component surface temperature rise must be lower than the limits in Fig.23.
5. Since in circuits used at voltages over 280 V peak-to-peak the risk for an intrinsically active flammability after a capacitor breakdown (short circuit) increases, it is recommended that the power to the component is limited to 100 times the values mentioned in Table 1 "Heat conductivity".
6. When using these capacitors as across-the-line capacitor in the input filter for mains applications or as series connected with an impedance to the mains the applicant must guarantee that following conditions are fulfilled in any case (spikes and surge voltages from the mains included).

VOLTAGE CONDITIONS FOR 6 ABOVE

ALLOWED VOLTAGES	$T_{amb} < 85 \text{ °C}$	$85 < T_{amb} \leq 100 \text{ °C}$	$100 < T_{amb} \leq 125 \text{ °C}$
Maximum continuous RMS voltage	$1 \times U_{Rac}$	$0.8 \times U_{Rac}$	$0.5 \times U_{Rac}$
Maximum temporary RMS -overvoltage (<24 hours)	$1.25 \times U_{Rac}$	$1.0 \times U_{Rac}$	$0.625 \times U_{Rac}$
Maximum peak voltage (V_{o-p}) (<2 s)	$1.6 \times U_{Rdc}$	$1.3 \times U_{Rdc}$	$0.8 \times U_{Rdc}$

Metallized polyester film capacitors

MKT 470

MARKING

Product marking

The capacitors are marked by YAG laser on the side (see Fig.25) with the following information:

1. Capacitance code in accordance with "IEC 60062"
2. Tolerance on rated capacitance: K = ±10%; J = ±5%
3. Rated (DC) voltage (e.g. 63 V)
4. Manufacturer
5. Year and week of manufacture (e.g. 9710)
6. Manufacturers type designation (e.g. 470).

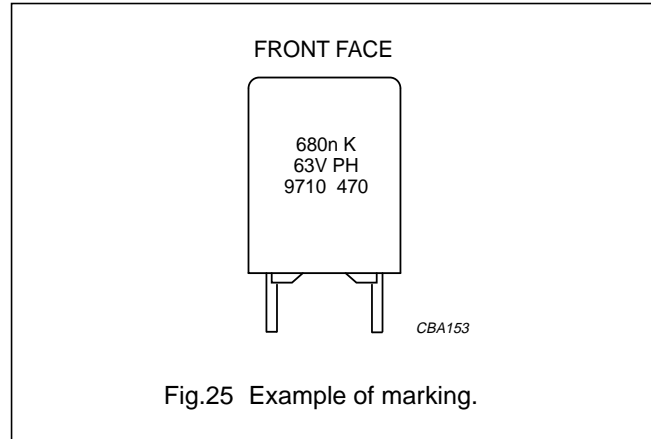

Fig.25 Example of marking.

Package marking

The package containing the capacitors is marked as shown in Fig.26.

Please note:
In due time BC COMPONENTS
will replace PHILIPS COMPONENTS

<ol style="list-style-type: none"> 1. PHILIPS COMPONENTS 2. MADE IN BELGIUM 3. METAL. PETP FILM CAPACITOR 4. MKT RADIAL POTTED TYPE 5. 0.68μF ±10% 63V= 55/125/56 6. 7. ORIG A170 RPC HQ 8. TYPE MKT 470 9. QTY 2000 DATE 9626 10. COEENO 2222 470 11684 	<p>Barcode label marking</p> <table style="width: 100%; border-collapse: collapse;"> <thead> <tr> <th style="text-align: left;">LINE</th> <th style="text-align: left;">MARKING EXPLANATION</th> </tr> </thead> <tbody> <tr><td>1</td><td>Manufacturer's name</td></tr> <tr><td>2</td><td>Country of origin</td></tr> <tr><td>3</td><td>Sub-family</td></tr> <tr><td>4</td><td>Type description</td></tr> <tr><td>5</td><td>Capacitance value, tolerance and climatic category ("IEC 60068-1")</td></tr> <tr><td>6</td><td>–</td></tr> <tr><td>7</td><td>Preference origin code: A Country of origin in code: 170 (Belgium) Responsible production centre: HQ Work order: WO Wage number of final inspection</td></tr> <tr><td>8</td><td>Product type description</td></tr> <tr><td>9</td><td>Quantity and production period, year and week code</td></tr> <tr><td>10</td><td>Product code (12NC)</td></tr> </tbody> </table>	LINE	MARKING EXPLANATION	1	Manufacturer's name	2	Country of origin	3	Sub-family	4	Type description	5	Capacitance value, tolerance and climatic category ("IEC 60068-1")	6	–	7	Preference origin code: A Country of origin in code: 170 (Belgium) Responsible production centre: HQ Work order: WO Wage number of final inspection	8	Product type description	9	Quantity and production period, year and week code	10	Product code (12NC)
LINE	MARKING EXPLANATION																						
1	Manufacturer's name																						
2	Country of origin																						
3	Sub-family																						
4	Type description																						
5	Capacitance value, tolerance and climatic category ("IEC 60068-1")																						
6	–																						
7	Preference origin code: A Country of origin in code: 170 (Belgium) Responsible production centre: HQ Work order: WO Wage number of final inspection																						
8	Product type description																						
9	Quantity and production period, year and week code																						
10	Product code (12NC)																						

CCA332

Fig.26 Barcode label.

Metallized polyester film capacitors

MKT 470

QUICK REFERENCE TEST REQUIREMENTS (see note 1)

TEST	PROCEDURE (quick reference)	REQUIREMENTS
Robustness of leads		
Tensile strength: "IEC 60068-2-21"	load 10 N; 10 s	no visible damage legible marking $ \Delta C/C \leq 2\%$ $\Delta \tan \delta \leq 50 \times 10^{-4}$ ($C \leq 10$ nF) $\Delta \tan \delta \leq 30 \times 10^{-4}$ (10 nF $< C \leq 470$ nF) $\Delta \tan \delta \leq 20 \times 10^{-4}$ ($C > 470$ nF)
Bending: "IEC 60068-2-21"	load 5 N; $4 \times 90^\circ$	
Resistance to soldering heat: "IEC 60068-2-20"	solder bath: 260 °C; 10 s	
Component solvent resistance	isopropyl alcohol; 23 °C; 5 minutes	
Robustness of component		
Vibration: "IEC 60068-2-6"	10 to 55 Hz; amplitude 0.75 mm or acceleration 98 m/s ² ; 6 hours	$ \Delta C/C \leq 5\%$ for $b = 2.5$ mm or $ \Delta C/C \leq 3\%$ for $b > 2.5$ mm $\Delta \tan \delta \leq 50 \times 10^{-4}$ ($C \leq 10$ nF) $\Delta \tan \delta \leq 30 \times 10^{-4}$ (10 nF $< C \leq 470$ nF) $\Delta \tan \delta \leq 20 \times 10^{-4}$ ($C > 470$ nF)
Shock: "IEC 60068-2-27"	half sinewave; 490 m/s ² ; 11 ms	
Climatic sequence		
Dry heat: "IEC 60068-2-2"	16 hours; 125 °C	$ \Delta C/C \leq 5\%$ $\Delta \tan \delta \leq 80 \times 10^{-4}$ ($C \leq 10$ nF) $\Delta \tan \delta \leq 50 \times 10^{-4}$ (10 nF $< C \leq 470$ nF) $\Delta \tan \delta \leq 30 \times 10^{-4}$ ($C > 470$ nF) $R_{ins} \geq 50\%$ of specified value
Damp heat, cyclic, test Db, first cycle: "IEC 60068-2-30"		
Cold: "IEC 60068-2-1"	2 hours; -55 °C	
Damp heat, cyclic, test Db, remaining cycles: "IEC 60068-2-30"		
Other applicable tests		
Damp heat steady state: "IEC 60068-2-3"	56 days; 40 °C; 90 to 95% RH	$ \Delta C/C \leq 5\%$ $\Delta \tan \delta \leq 50 \times 10^{-4}$ ($C \leq 470$ nF) $\Delta \tan \delta \leq 30 \times 10^{-4}$ ($C > 470$ nF) $R_{ins} \geq 50\%$ of specified value
Endurance (DC): "IEC 60384-2"	2000 hours; $1.25 \times U_{Rdc}$; 85 °C $0.625 \times U_{Rdc}$; 125 °C	
Heat storage: "IEC 60384-2"	2000 hours; 125 °C	$ \Delta C/C \leq 5\%$ $\Delta \tan \delta \leq 50 \times 10^{-4}$ ($C \leq 10$ nF) $\Delta \tan \delta \leq 30 \times 10^{-4}$ (10 nF $< C \leq 470$ nF) $\Delta \tan \delta \leq 20 \times 10^{-4}$ ($C > 470$ nF)

Metallized polyester film capacitors

MKT 470

TEST	PROCEDURE (quick reference)	REQUIREMENTS
Resistance to detergents	3 minutes in dishwater at 70 °C	$ \Delta C/C \leq 1\%$ $\Delta \tan \delta \leq 50 \times 10^{-4}$ ($C \leq 10$ nF) $\Delta \tan \delta \leq 30 \times 10^{-4}$ (10 nF < $C \leq 470$ nF) $\Delta \tan \delta \leq 20 \times 10^{-4}$ ($C > 470$ nF) $R_{\text{ins}} \geq 50\%$ of specified value
Resistance to soldering heat with preheating: "IEC 60384-2"	body temperature: 125 °C; bath temperature: 260 °C; dwell time: 5 s	$ \Delta C/C \leq 3\%$ for $b = 2.5$ mm or $ \Delta C/C \leq 5\%$ for $b > 2.5$ mm $\Delta \tan \delta \leq 50 \times 10^{-4}$ ($C \leq 10$ nF) $\Delta \tan \delta \leq 30 \times 10^{-4}$ (10 nF < $C \leq 470$ nF) $\Delta \tan \delta \leq 20 \times 10^{-4}$ ($C > 470$ nF)
Passive flammability: "IEC 60384-1"	class C	no burning

Note

1. For detailed information: see "Type detail specification HQN-384-02/104".

X-ON Electronics

Largest Supplier of Electrical and Electronic Components

Click to view similar products for [vishay](#) manufacturer:

Other Similar products are found below :

[M39006/22-0577H](#) [Y00892K49000BR13L](#) [VS-12CWQ10FNPBF](#) [M8340109M6801GGD03](#) [VS-MBRB1545CTPBF](#) [1KAB100E](#)
[CRCW1210360RFKEA](#) [VSMF4720-GS08](#) [CRCW04024021FRT7](#) [001789X](#) [LTO050FR0500JTE3](#) [CRCW0805348RFKEA](#)
[LVR10R0200FE03](#) [CRCW12063K30FKEAHP](#) [009923A](#) [CRCW2010331JR02](#) [CRCW25128K06FKEG](#) [CS6600552K000B8768](#) [M39003/01-2289](#) [M39003/01-2784](#) [M39006/25-0133](#) [M39006/25-0228](#) [M64W101KB40](#) [M64Z501KB40](#) [CW001R5000JS73](#) [CW0055R000JE12](#)
[CW0056K800JB12](#) [CW0106K000JE73](#) [672D826H075EK5C](#) [CWR06JC105KC](#) [CWR06NC475JC](#) [MAL219699001E3](#)
[MCRL007035R00JHB00](#) [PTF56100K00QYEK](#) [PTN0805H1502BBTR1K](#) [RCL12252K20JNEG](#) [RCWL1210R130JNEA](#) [RH005220R0FE02](#)
[RH005330R0FC02](#) [RH010R0500FC02](#) [132B20103](#) [RH1007R000FJ01](#) [RH2503R500FE01](#) [RH254R220FS03](#) [RH-50-40R2-1%-C02](#)
[134D336X9075C6](#) [132B00301](#) [135D277X0025F6](#) [DG202BDY-T1-E3](#) [DG9426EDQ-T1-GE3](#)