

Technical data



Stabex mini



Stabex HF



Charger LG 493

Stabex mini

Marking accd. 94/9/EC	⊕ II 2 G / ⊕ II 2 D
Type of protection	EEx ib e IIC T5
EC-Type Examination Certificate	PTB 98 ATEX 2061
Enclosure material	Polycarbonate / black
Light aperture	Mineral glass, Ø 23 mm
Tungsten lamp	2.2 V / 0.4 A
Protection category	IP 65 acc. to EN 60529
Permissible ambient temperature	-20°C to +40°C
Battery	Specified data: 0°C to +30°C (battery)
Duration	2 dry cells AA-size, IEC 86 R 6 / LR 6
Weight	approx. 8 h
	approx. 0.07 kg without batteries

Stabex HF

Marking accd. 94/9/EC	⊕ II 2 G / ⊕ II 2 D
Type of protection	EEx ib e IIC T4
EC-Type Examination Certificate	PTB 98 ATEX 2062
Enclosure material	Polyamide / black
Light aperture	Mineral glass, Ø 48 mm
Halogen lamp	2.8 V / 0.5 A
Protection category	IP 65 acc. to EN 60529
Permissible ambient temperature	-20°C to +40°C
Battery	Specified data: 0°C to +30°C (battery)
	2 dry cells D-size, IEC 86 R 20 / LR 20
	2 rechargeable NiCd accumulators
Duration	Dry cells apx. 12 h, NiCd apx. 7 h
Weight	approx. 0.25 kg without batteries

Charger LG 493

Protection category	IP 31
Input voltage	220 - 250 V AC, ±10 % 50/60 Hz
Power consumption	12 VA
Recharge period	max. 14 h (depending on the state of charge)
Weight	approx. 1.3 kg

* II 2 D applied for

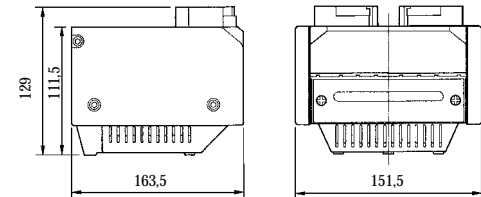
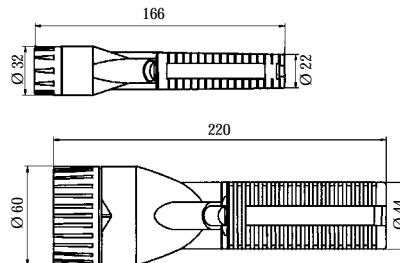



Stabex M0 (zone 0)

Technical data

Stabex M0

Marking accd. 94/9/EC	⊕ III G / ⊕ II 2 D
Type of protection	EEx ib ed IIC T6
EC-Type Examination Certificate	PTB 99 ATEX 2197
Housing	Stainless steel
Light aperture	Ø 44 mm, mineral glass
Tungsten lamp	2.5 V / 0.3 A
Protection category	IP 65 acc. to EN 60529
Max. permitted height of fall	5 m
Permissible ambient temperature	-20°C to +40°C Specified data: 0°C to +30°C (battery)
Battery	2 dry cells D-size IEC 86 R 20 / LR 20
Duration	approx. 12 h (Alkali manganese battery)
Luminous flux	approx. 12 lm
Weight	approx. 2.2 kg (without batteries)

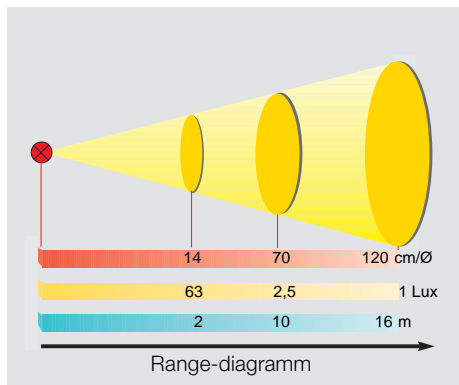

Dimensions in mm

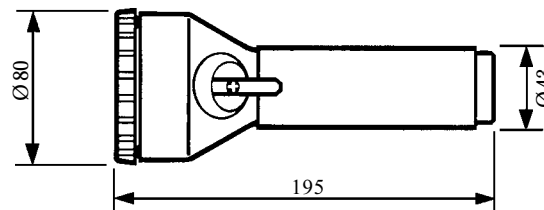

Technical data



HE 5 EN

HE 5 EN	
Marking accd. 94/9/EC	II 2 G
Type of protection	EEx ib e IIC T6
EC-Type Examination Certificate	PTB 99 ATEX 2196
Enclosure material	Polyamide / black
Light aperture	Ø 40 mm, mineral glass
Tungsten lamp	3.75 V / 0.3 A
Switch	"ON - OFF" slide-switch
Protection category	IP 54 acc. to EN 60529
Permissible ambient temperature	-20°C to +40°C
Battery	Specified data: 0°C to +30°C (battery)
Duration	Standard flat battery 4.5 V (IEC 86 3 R 12) approx. 6 h
Weight	approx. 0.14 kg (without battery)

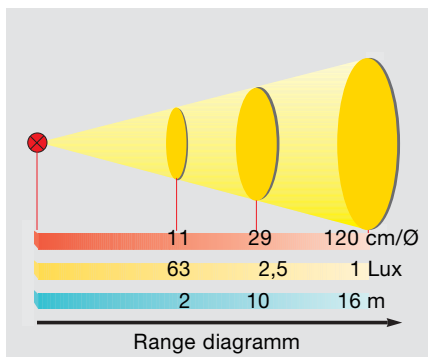

Dimensions in mm

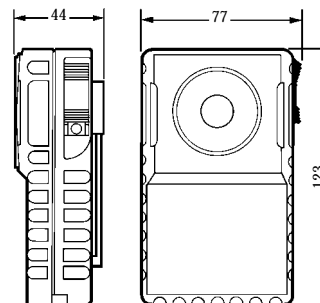



HE 8 N EN



LG 483 charger

Technical data

HE 8 N EN

Marking accd. 94/9/EC	⊕ II 2 G/ ⊕ II 2 D
Type of protection	EEx e ib IIC T4
EC-Type Examination Certificate	PTB 98 ATEX 2063
Enclosure material	Polyamide / black
Light aperture	Ø 71 mm, mineral glass
Tungsten lamp	3.75 V / 0.8 / 0.4 A
Rotary switch	3 positions Main beam - OFF - signal light (red)
Protection category	IP 65 acc. to EN 60529
Permissible ambient temperature	-20°C to +40°C Specified data: 0°C to +30°C (battery)
Battery	Chargeable NiCd battery (3.6 V/4 Ah)
Duration	approx. 5 h - Indication of available duration
Functions	- Emergency light in case of a mains failure - Charge depending on the drawn capacity - Red signal light, switchable - Switching for stand-by light or in case of a broken filament
Weight	approx. 1.7 kg (with battery)

LG 483 charger

Protection category	IP 31
Input voltage	220-250 V AC, ±10 %, 50/60 Hz
Input power	12 VA
Recharge period	max. 8 h (depending on charging state)
Weight	approx. 1.3 kg

* II 2 D applied for

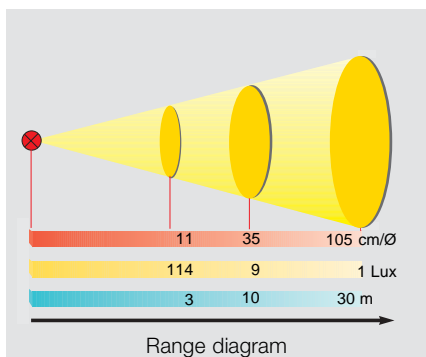

Dimensions in mm

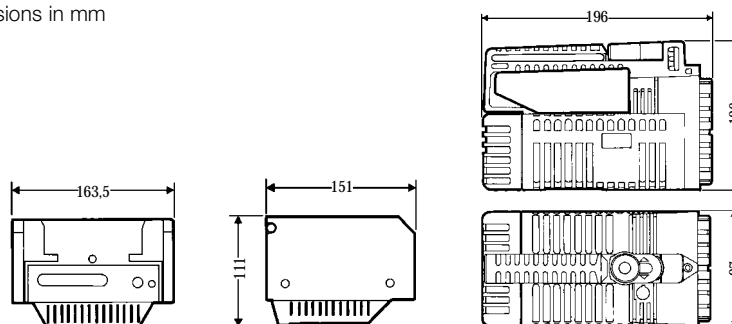



HE 8 EURO



HE 8 EURO PLUS



Plug-in charger

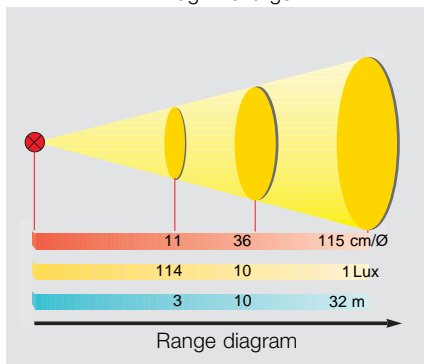

Technical data

HE 8 EURO/HE 8 EURO PLUS

Marking accd. 94/9/EC	⊕ II 2 G/ ⊕ II 2 D
Type of protection	EEx e ib IIC T4
EC-Type Examination Certificate	PTB 98 ATEX 2063
Enclosure material	Polyamide / black
Light aperture	Ø 71 mm, mineral glass
Halogen lamp	4 V / 0.82 A
Protection category	IP 65 acc. to EN 60529
Permissible ambient temperature	-20°C to +40°C Specified data: 0°C to +30°C (battery)
Battery	HE 8 EURO battery insert to be equipped with of 3 x 1.5 V dry batteries/IEC 86, R 20/LR 20 HE 8 EURO PLUS battery insert with 3.6 V/5 Ah rechargeable battery
Duration	approx. 10 h (HE 8 EURO) approx. 5 h (HE 8 EURO PLUS) - easily replaceable battery insert
Functions	- halogen lamp with double bulb - indication of available duration (EURO PLUS) - protection against overcharge (EURO PLUS)
Weight	approx. 0.64 kg (HE 8 EURO, without battery) approx. 1.0 kg (HE 8 EURO PLUS)

Plug-in charger for HE 8 EURO PLUS

Protection category	IP 20
Input voltage	230 V ± 10 %, 50/60 Hz
Input power	6.5 VA
Recharge period	max. 14 h (EURO PLUS)
Insulation class	II
Weight	approx. 0.42 kg

Dimensions in mm

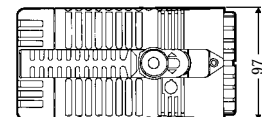
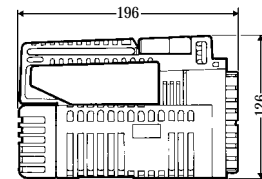



SEB 8
with motor vehicle charger 90



Charger LG 443

Technical data

SEB 8 L / SEB 8

Marking accd. 94/9/EC	⊕ II 2 G / ⊕ II 2 D
Type of protection	EEx e ib IIC T4
EC-Type Examination Certificate	PTB 99 ATEX 2195
Enclosure material	Polyamide / black
Light aperture	Ø 98 mm mineral glass
Halogen lamp with double bulb	5.5 V / 5.5 W
Tungsten lamp	4.8 V / 0.3 A
Protection category	IP 65 acc. to 60529
Permissible ambient temperature	-20°C to +40°C (Specified data: 0-30°C)
Battery	Rechargeable NiCd battery (4.8 V/7 Ah)
Duration	approx. 6.5 h
Functions	<ul style="list-style-type: none"> - Indication of available duration processor controlled - Charge depending on the drawn capacity - Flashlight - Emergency light in case of a mains failure - Safety circuit for broken filament or stand-by light - Integrated charger (SEB 8 L)
Weight	SEB 8L: 2.5 kg/ SEB 8: 2.2 kg
LG 443 charger, input voltage	
SEB 8 / SEB 8 L	220-250 V ± 10 %, 50/60 Hz ¹⁾
Motor vehicle charger 90, input voltage	
SEB 8 / SEB 8 L	10-33 V DC
Integrated charger SEB 8 L, input voltage	230 V ± 10 %; 50/60 Hz

* II 2 D applied for
¹⁾ 110 V on request

Dimensions in mm

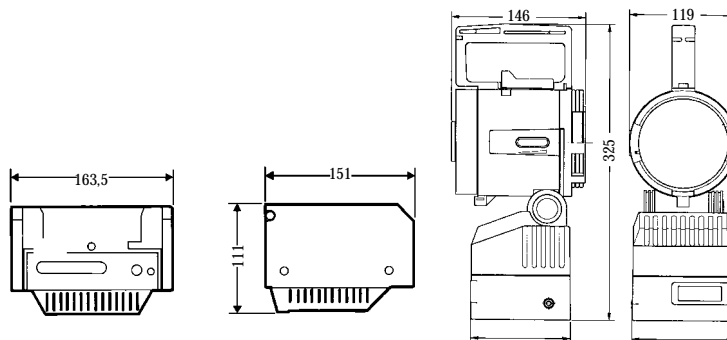
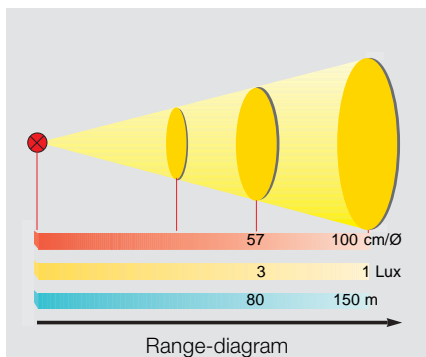



HLE 7 L EN

Technical data

HLE 7 L EN

Marking accd. 94/9/EC	Ex II 2 G
Type of protection	EEx e ib IIC T4
EC-Type Examination Certificate	PTB 99 ATEX 2194
Housing	Polyamide / black
Light aperture	Ø 65 mm, mineral glass
Rotary switch	4 positions
Tungsten lamp	OFF - pilot light - OFF - main beam
Protection category	3.75 V / 0.8 / 0.3 A
Permissible ambient temperature	IP 54
Battery	-20°C to +40°C
Duration	Specified data: 0°C to +30°C (battery)
Input voltage	chargeable NiCd battery (3.6 V / 7 Ah)
Insulation class	approx. 8 h
Input power	230 V ± 10 %, 50/60 Hz
Permissible mean ambient temperature during charge	II
Recharge period	4 VA
Functions	- Indication of the charging state
	- Two-filament lamp
	- Integrated charger
Weight	approx. 2.0 kg (with battery)

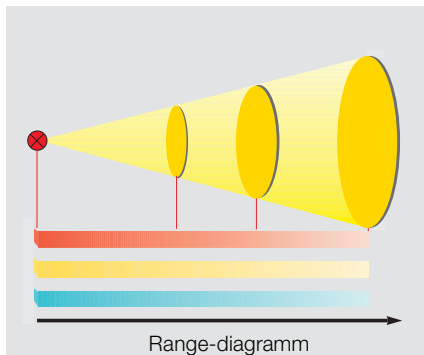

Dimensions in mm

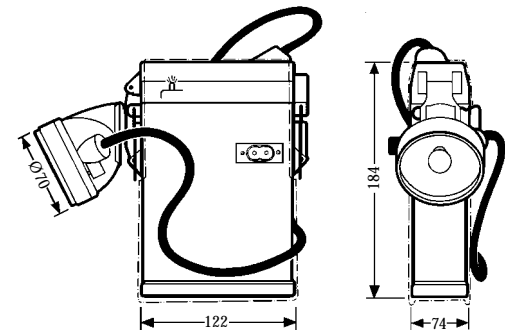

X-ON Electronics

Largest Supplier of Electrical and Electronic Components

Click to view similar products for [eaton](#) manufacturer:

Other Similar products are found below :

[BK1-S506-500-R](#) [BK-MDL-3-R](#) [BK1-S506-6-3-R](#) [BK1-S506-2-R](#) [MPI4040R4-1R5-R](#) [TDC600-10A](#) [89096-015](#) [8946K153](#) [8961K155](#)
[M22-D-R-GB0/K11](#) [M22-L-R/R](#) [M22S-ST-GB12](#) [630NHG3B](#) [63ET](#) [6422](#) [6580](#) [CTX20-16-52LP-R](#) [CWL530FI](#) [CXM/CO/GP/R/BB](#)
[6HD36](#) [714125](#) [MBO-2](#) [ESR5-NO-41-24VAC-DC](#) [7314K36](#) [7321K2](#) [F02A-1-1/2A](#) [F02A-1-1/2AS](#) [F02A-1AS](#) [F02A-2AS](#) [F02A-3/4A](#)
[F03A250V12A](#) [F03B125V4A](#) [MCR-4](#) [MDA-2-8/10-R](#) [MDA-30A](#) [MDA-V-1/16](#) [F60C500V10AS](#) [F60C500V15AS](#) [7563K84](#) [7634K36](#)
[MDQ-3/16](#) [MDQ-7/10](#) [MDQ-V-1/10](#) [MDQ-V-1-1/4](#) [MDQ-V-1/16](#) [MDQ-V-1/2](#) [MDQ-V-1/4](#) [MDQ-V-3/16](#) [MDQ-V-3/8](#) [MDQ-V-6/10](#)