

Function codes

Essential Function codes for Quick basic set up

Code	Description	Factory settings	Comments/change to:-
F01	Freq reference source	4=On-board potentiometer	1=External 0-10v (max) to terminal 12 2=External 4-20mA (max) to terminal C1
F02	RUN/STOP command source	2=RUN & STOP commands via keypad only	1=Terminals only, FWD and REV inputs active
F04	Motor base Frequency	50.0Hz	Frequency shown on motor rating plate (Hz)
F05	Motor rated Volts at base frequency	0=Motor V=Inverter Input V at base frequency	Voltage shown on motor rating plate (V)
F11	Motor overload	Nominal rated current of like-sized 4P motor (A)	Required motor overload level (A)- Reduce for smaller motor
P02	Motor capacity	Nominal motor power (kW)	Power shown on motor rating plate (kW)
P03	Motor rated current	Rated current of P02 (A)	Current shown on motor rating plate (A)

Additional function codes that may be changed for general NT application

Code	Description	Factory setting	Comments/change to:-
F03	Max. Frequency	50 Hz	Maximum desired motor operating frequency (relating to maximum operating speed)
F07	Accelerating time	6.00 seconds	Required time for motor to accelerate 0Hz to maximum frequency
F08	Decelerating time	6.00 seconds	Required time for motor to decelerate from maximum frequency to 0Hz
F09	Torque boost	*	F09=0.0 TO 20.0%(Works in conjunction with F37)
F15	Frequency High limit	70.0Hz	These values define the output frequency range for a given input range, ie 0 to 10V input reference gives 20Hz-45Hz output when F15=45 and F16=20
F16	Frequency Low limit	0.0Hz	
F26	PWM carrier frequency	15kHz	Reducing level gives noisier motor but less RF interference and lower earth leakage from motor cable (and vice-versa)
F37	Load selector	1 (HT load)	F37=0 or 3 (Works in conjunction with F09)

Additional function codes that may be changed for HT application

Code	Description	Factory setting	Comments/change to:-
F09	Torque boost	*	F09=0.0 (Auto boost) (Works in conjunction with F37)
F37	Load selector	1 (HT load)	Best could be F37=2 (Auto boost) But could be F37=1 or 4 (manual Boost) (Works in conjunction with F09)
P09	Motor slip compensation	0.0%	Most commonly acts to compensate for decreasing shaft speed as load increases

Note 1: NT denotes normal or variable torque load such as a fan or centrifugal pump etc.
HT denotes high/heavy or constant torque application, ie - mixer, hoist, screw feeder, p.d. pump, etc.
Note 2: All other settings including: thermistor input, PID control, I/O configuration etc and for further full set information, please refer to Cub instruction manual.

Note 3: *Factory set value depends upon rated power of Jaguar Cub/ model number.

If in doubt - consult IMO or CUB instruction manual

Technical data

	Single phase input				Three phase input					
	3A-1	5A-1	8A-1	11A-1	1A5-4	2A5-4	3A7-4	5A5-4	9A-4	
Inverter Type (CUB)										
Output Ratings										
Nominal Applied Motor	kW	0.4	0.75	1.5	2.2	0.4	0.75	1.5	2.2	4
Rated voltage	V	Three Phase 200-230v 50/60Hz				Three Phase 380-415v/50Hz 380-460/60Hz				
Rated Current	A	3	5	8	11	1.5	2.5	3.7	5.5	9
Overload capacity	A	150% of rated output current for 1 min 200% of rated output current for 0.5s				150% of rated output current for 1 min 200% of rated output current for 0.5s				
Input Ratings										
Rated voltage	kW	Single Phase 200-240v 50/60Hz				Three Phase 380-480v, 50/60Hz				
Fuse Rating	A	10	16	20	32	6	10	10	16	20
Rated Current	A	5.4	9.7	16.4	24.8	1.7	3.1	5.9	8.2	13.0
Cable Sizes										
Mains Supply without DCR	mm ²				4					
Motor Cable	mm ²	2.5	2.5	2.5	2.5	2.5	2.5	2.5	2.5	2.5
Earth Cable	mm ²				4					
Braking resistor cable	mm ²				2.5					
Max Length (m) Screened Cable		50	50	50	50	50	50	50	50	50
Braking resistor	Ω	100			40	200		160		130
	W	200			400	200		400		
Cooling Method		Natural Cooling			Fan Cooling	Natural Cooling		Fan Cooling		
Enclosure	IP	IP20				IP20				
Weight	Kg	0.6	0.8	1.7	2.3	1.1	1.2	1.7	1.7	2.3

Note 4: Fuse ratings and rated input currents are typical with no DCR.

Note 5: Fuse and cable ratings are for guidance only. Local practise and regulations must take priority.

Alarm codes

Code	Name	Code	Name	Code	Name
OC1	Overcurrent trip during acceleration	Lin	Input phase loss protection	OLU	Overload protection
OC2	Overcurrent trip during deceleration	OPL	Output phase loss protection	Er1	Memory error
OC3	Overcurrent trip during steady speed	OH1	Overheat protection for heat sink	Er2	Remote keypad communications error
OU1	Overvoltage trip during acceleration	OH2	External alarm input trip	Er3	CPU error
OU2	Overvoltage trip during deceleration	OH4	PTC thermistor for motor protection	Er6	Operation protection
OU3	Overvoltage trip during steady speed	dbH	Overheat protection for braking resistor	Er8	RS485 communication error
LU	Undervoltage protection	OL1	Electronic thermal overload relay	ErF	Data save error during undervoltage



IMO Precision Controls Ltd.
1000 North Circular Road, Staples Corner, London NW2 7JP, United Kingdom
Tel: +44(0)20 8452 6444 Fax: +44(0)20 8450 2274 Email: imo@imopc.com Web: www.imopc.com



Quick reference guide

Connections

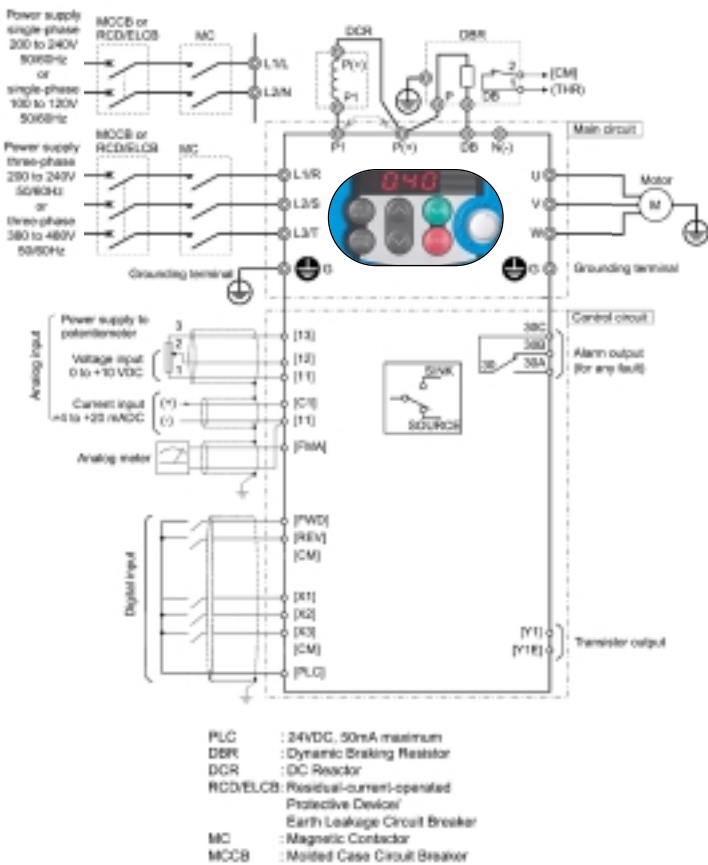

The above data is for basic reference only.
 It is strongly recommended to use the correct EMC filter and screened/armoured motor cable (not shown).
WARNING: THIS EQUIPMENT MUST BE EARTHED

If in doubt - consult IMO or CUB instruction manual

Basic key operations



04 7-segment LED display shows In Run mode: Hertz, Amps, Volts, kW, I/O signal status, run time, rpm, PID values. In Program mode:

Menus, Function codes and their data. In Alarm mode: Trip codes and alarm information.

STOP Motor RUN and STOP keys active only when inverter is operating in keypad mode.

0.0 On-board frequency setting potentiometer.

PRG/RESET key. Use to change operating modes. In Run mode: press to enter program mode. In Program mode: press to enter run mode. In Alarm mode: Resets a trip condition (after fault has been removed).

FUNC/DATA key. In Run mode: press to change display from Output frequency _ Motor current (A)_ Power (P) _ Output voltage (V) _ Out. In Program mode: press to display function code value or to store / write data to memory. In Alarm mode: Displays information about alarm state shown on LED panel.

UP/DOWN keys used to scroll through menus and function codes, also used to increase/ decrease actual set value of function codes (value must be stored in memory by pressing FUNC/DATA key). When operating in keypad mode they are used to increase/decrease motor speed.

Simultaneous Keying In Run mode: STOP + UP keys together – gives entry to or exit from jogging operation. In Program mode: STOP + DOWN keys together – allows changes to special function codes

F00 (Data protection) and H03 (Reset all function codes to factory set default values). In Alarm mode: STOP + PRG/RESET keys together – switches to program mode without resetting trip condition.

If in doubt - consult IMO or CUB instruction manual

Programming Mode

Getting started

Example of changing a typical parameter; Function P02 (motor capacity) from say 0.75kW to 0.55kW. This would be necessary if a Cub 5A-1 (0.75kW / 230V – 1ph inverter) or Cub 2A5-4 (0.75kW / 415V – 3ph inverter) was to be used to drive a 0.55kW motor. In this case it would be necessary to check / change P03 (rated current) and other function codes.

START



Connect mains, motor and earth cables as shown in the diagram. Connect all necessary control circuits. Check all wiring for faults / errors. Switch power ON.



Display flashes a frequency value from on-board pot, say 0.00 (Hz) or other value.



Press PRG/RESET key. Display shows 1.F_ (1 is flashing).



Press UP key three times. Display shows 1.P_ (1 is flashing).



Press FUNC/DATA key. Display shows P.02 (2 is flashing).



Press FUNC/DATA key. Display shows 0.75 (5 is flashing).



Press DOWN key until display shows 00.55 (last 5 is flashing).



Press FUNC/DATA key until display shows SAVE (last 5 is flashing).

DONE!

Display automatically moves to next function number (P03 in this case) Press PRG/RESET key to escape.

Menu #	Menu	Displays	Main functions	
#1	Data setting	1.F##	F codes (Fundamental functions)	Selecting these codes enables data to be displayed or changed
		1.E##	E codes (Extension terminal functions)	
		1.C##	C codes (Frequency control functions)	
		1.P##	P codes (Motor parameters)	
		1.H##	H codes (High performance functions)	
		1.J##	J codes (Application functions)	
		1.y##	Y codes (Application functions)	
#2	Data check	2.rEP	Display only those function codes that have been changed from factory set defaults.	
#3	Drive monitor	3.oPE	Display Hz, rmp, A, kW, V(O/P), PID values etc.	
#4	I/O check	4.i_0	Display drive control input and output status.	
#5	Maintenance check	5.CHE	Display maintenance information including accumulated hours run time.	
#6	Alarm information	6.AL	Display the last four alarm codes and running data at the time of last trip condition.	
#7	Data copy	7.CPy	Feature for reading, writing and verifying data for transferring to other drives of same type (remote keypad only).	

If in doubt - consult IMO or CUB instruction manual



X-ON Electronics

Largest Supplier of Electrical and Electronic Components

Click to view similar products for imo manufacturer:

Other Similar products are found below :

[20.155MV/12-E](#) [MC14N-S-10110AC](#) [MB09-S-10=24](#) [DPS-1-030-24](#) [SRF-1C-SL-12VDC](#) [MB09-S-1024](#) [LDC18RRS](#) [SFSYE0111](#)
[21.1500M/6-E](#) [20.3304M/2-E](#) [21.910M/5-E](#) [20.95MA/2-E](#) [21.95MHF/2-E](#) [PE69-4032](#) [DPS-1-060-24](#) [CS20A-A2](#) [CS20A-U1](#) [VFC02](#)
[MSSTC11DA06](#) [20.95MHF/3-E](#) [B3T10](#) [XKL-040-21](#) [20.3304M/4-E](#) [SRDH-1A-SL-24VDC](#) [20.2500M/5-E](#) [21.155MH/12](#) [SRRHN-2CN-](#)
[SL-12VDC](#) [20.920M/5-E](#) [MC10N-S-10110AC](#) [21.1550MF/8-E](#) [20.910M/6-E](#) [20.95MH/3-E](#) [21.95MV/3](#) [MA05-S-01230AC](#) [SRRHN-2CN-](#)
[SL-5VDC](#) [LB69-4040](#) [20.3001M/6](#) [21.1500M/3-E](#) [SFSYE0311](#) [21.95MHF/6-E](#) [20.95MV/2-E](#) [20.155MV/4-E](#) [20.155MH/4-E](#) [20.950M/2-E](#)
[MT5 1-50-FAR](#) [BS3P3REDO](#) [MB12-S-10=24](#) [MA05-S-1024DC](#) [20.155MVF/8-E](#) [20.2500MV/8-E](#)