

DETAIL A  
TUBE PACKAGING  
SCALE 2:1

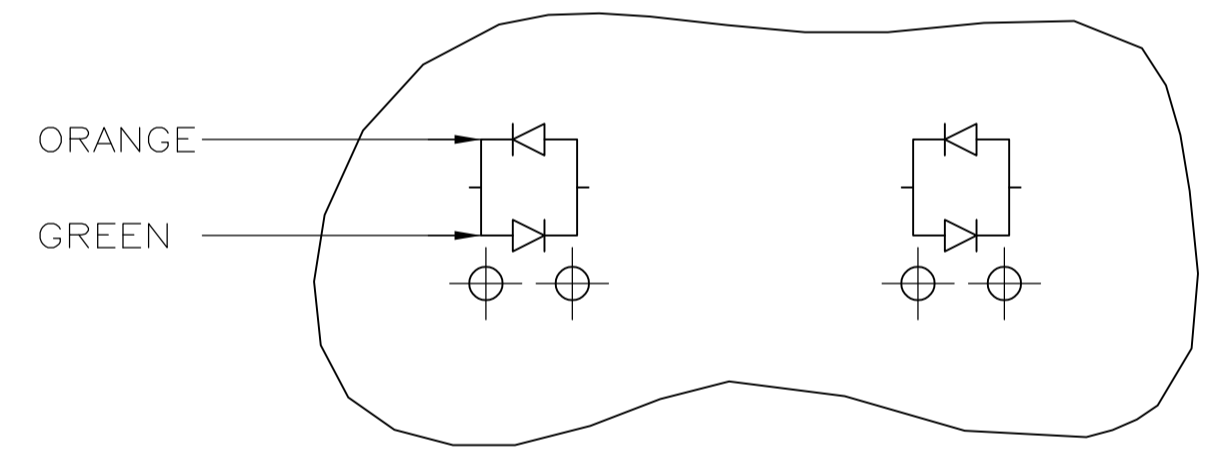

LED CURRENT DIAGRAM  
406507-7, 1-406507-7,  
AND 3-406507-7

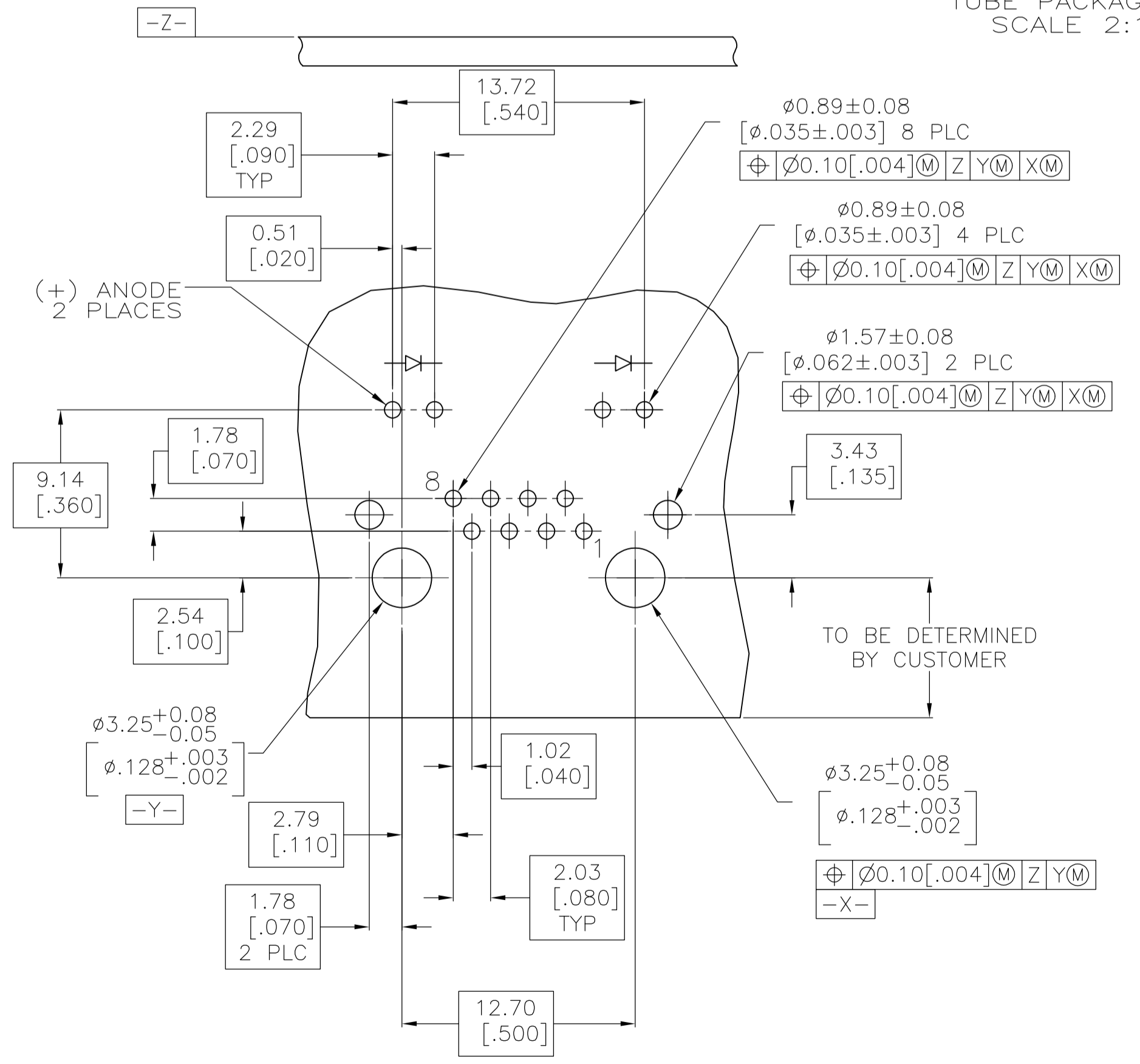

RECOMMENDED PRINTED CIRCUIT BOARD  
(COMPONENT SIDE)

- △ MATERIAL:  
HOUSING - HIGH TEMPERATURE THERMOPLASTIC, BLACK, UL94V-0.  
TERMINALS - 0.36[.014] THICK PHOS BRONZE PLATED WITH 3.81µm[.000150] MINIMUM THICK (SEE P/N TABLE) IN SOLDER AREA. 1.27µm[.000050] MINIMUM GOLD IN LOCALIZED PLATE AREA. ENTIRE TERMINAL PLATED WITH 1.27µm[.000050] MINIMUM THICK NICKEL.  
SHIELD - 0.196[.0077] THICK COPPER ZINC ALLOY PREPLATED WITH 1.27µm[.000050] MINIMUM SATIN NICKEL WITH 2.03µm[.000080] MINIMUM TIN POST DIPPED ON PCB GROUND TABS.  
LIGHT EMITTING DIODE (LED) - DIFFUSED EPOXY LENS, 0.51 x 0.51[.020 x .020] CARBON STEEL WIREFRAME LEADS PLATED WITH 8.89µm[.000350] TIN/COPPER OVER 2.03µm[.000080] SILVER OVER 1.02µm[.000040] NICKEL UNDERPLATE OVER 2.03µm[.000080] COPPER UNDERPLATE.
- 2. JACK CAVITY CONFORMS TO FCC RULES AND REGULATIONS PART 68, SUBPART F.
- △ SUGGESTED PANEL OPENING DIMENSIONS.
- △ SUGGESTED CLEARANCE BETWEEN TOP OF CONNECTOR AND TOP PANEL OPENING.
- 5. 0.051[.002] WHITE POLYESTER INSULATOR APPLIED TO BACK OF HOUSING.
- △ SEE TABLE FOR COLOR OF LEDS AND NUMBER REQUIRED.
- 7. THIS MODULAR JACK WITH INTEGRATED LED IS NOT IR REFLOW SOLDERING PROCESS COMPATIBLE.
- △ PACKAGED 30 PIECES PER TUBE. SEE DETAIL "A".
- △ MANUFACTURING DATE CODE:  
LOCATED APPROX. AS SHOWN.  
FIRST 2 DIGITS = LAST 2 DIGITS OF YEAR.  
NEXT 2 DIGITS = MANUFACTURING WORK WEEK.  
LAST DIGIT = DAY OF WEEK WITH SUNDAY = 1.
- △ OBSOLETE PARTS: OBSOLETE CIS STREAMLINING PER D.RENAUD/D.SINISI

TERMINAL LEAD PLATING	DIM B SOLDER TAIL LENGTH	PACKAGING	INDICATOR COLOR		PART NUMBER
TIN-LEAD	2.54 [.100]	△ TUBE	GREEN	YELLOW	7-406507-4
MATTE TIN	3.05 [.120]	TRAY	ORANGE/GREEN	ORANGE/GREEN	3-406507-7
△ OBSOLETE	MATTE TIN 3.05 [.120]	TRAY	GREEN	GREEN	3-406507-5
△ OBSOLETE	MATTE TIN 3.05 [.120]	TRAY	GREEN	YELLOW	3-406507-4
△ OBSOLETE	MATTE TIN 3.05 [.120]	TRAY	YELLOW	GREEN	3-406507-1
MATTE TIN	2.54 [.100]	△ TUBE	GREEN	YELLOW	2-406507-4
△ OBSOLETE	MATTE TIN 2.54 [.100]	TRAY	ORANGE/GREEN	ORANGE/GREEN	1-406507-7
△ OBSOLETE	MATTE TIN 2.54 [.100]	TRAY	YELLOW	YELLOW	1-406507-6
MATTE TIN	2.54 [.100]	TRAY	GREEN	GREEN	1-406507-5
△ OBSOLETE	MATTE TIN 2.54 [.100]	TRAY	GREEN	YELLOW	1-406507-4
△ OBSOLETE	MATTE TIN 2.54 [.100]	TRAY	YELLOW	-	1-406507-3
MATTE TIN	2.54 [.100]	TRAY	-	GREEN	1-406507-2
△ OBSOLETE	MATTE TIN 2.54 [.100]	TRAY	YELLOW	GREEN	1-406507-1
TIN-LEAD	2.54 [.100]	TRAY	ORANGE/GREEN	ORANGE/GREEN	406507-7
△ OBSOLETE	TIN-LEAD 2.54 [.100]	TRAY	YELLOW	YELLOW	406507-6
△ OBSOLETE	TIN-LEAD 2.54 [.100]	TRAY	GREEN	GREEN	406507-5
△ OBSOLETE	TIN-LEAD 2.54 [.100]	TRAY	GREEN	YELLOW	406507-4
△ OBSOLETE	TIN-LEAD 2.54 [.100]	TRAY	YELLOW	-	406507-3
△ OBSOLETE	TIN-LEAD 2.54 [.100]	TRAY	-	GREEN	406507-2
△ OBSOLETE	TIN-LEAD 2.54 [.100]	TRAY	YELLOW	GREEN	406507-1

THIS DRAWING IS A CONTROLLED DOCUMENT. DIN T SPRINKLE 15SEP97  
CIRK T SPRINKLE 15SEP97

DIMENSIONS: mm [INCHES] TOLERANCES UNLESS OTHERWISE SPECIFIED:  
0 PLC ± -  
1 PLC ± -  
2 PLC ± 0.25[.01]  
3 PLC ± 0.13[.005]  
4 PLC ± -  
ANGLES ± -

MATERIAL △ FINISH △

THIS DRAWING IS A CONTROLLED DOCUMENT. DIN T SPRINKLE 15SEP97  
CIRK T SPRINKLE 15SEP97  
APVD M DERSTINE 090C197 NAME  
PRODUCT SPEC 108-1163-4  
APPLICATION SPEC 114-2154  
WEIGHT -  
CUSTOMER DRAWING

TE Connectivity  
INVERTED MODULAR JACK ASSEMBLY,  
1X1, SHIELDED, PANEL GROUND,  
LED, INSULATOR

SIZE CASE CODE DRAWING NO RESTRICTED TO  
A1 00779C=406507 -

SCALE 4:1 SHEET 1 OF 1 REV K4

## X-ON Electronics

Largest Supplier of Electrical and Electronic Components

*Click to view similar products for [Modular Connectors / Ethernet Connectors](#) category:*

*Click to view products by [TE Connectivity](#) manufacturer:*

Other Similar products are found below :

[RJE231881317T](#) [MP1010RX-1000](#) [MP44RX-1000](#) [GAX-3-66](#) [GAX-8-62](#) [93606-0253](#) [GD-A-44](#) [GDCX-PA-66-50](#) [GDCX-PN-64](#) [GDCX-PN-66](#) [GDCX-PN-66-50](#) [GDLX-A-66](#) [GDLX-A-88](#) [GDLX-N-66](#) [GDLX-S-88K](#) [GDTX-S-88-50](#) [GDX-PA-1010](#) [GLX-N-1010M-BLK](#) [GLX-N-44M](#) [GLX-S-88M-BLK](#) [GMX-N-1010](#) [GMX-S-1010](#) [GMX-S-66](#) [GMX-SMT2-N-1010](#) [GMX-SMT2-N-64-50](#) [GMX-SMT2-S6-88](#) [GMX-SMT4-N-88](#) [GPX-2-64](#) [GRT1-BT1-5](#) [GSGX-N-2-88](#) [GSX-NS2-88-3.05](#) [GSX-NS2-88-3.05-50](#) [GSX-NS-88-3.05-30](#) [GSX-NS-88-3.05-50](#) [GSX-NS-88-3.68](#) [1-1775629-2](#) [GWLX-S-88-GR](#) [GWLX-S9-88-YG](#) [1300500326](#) [1300500227](#) [1300530003](#) [1300570002](#) [1324640-4](#) [RJ11FTVC2G](#) [RJ11FTVC2N](#) [RJFTVX2SA1G](#) [132764-001](#) [1400000](#) [1413176](#) [1413235](#)