

This drawing involves proprietary design rights of Tyco Electronics Corporation, and all design, manufacture, reproduction, use and sale rights regarding the same are expressly reserved. It is submitted for a specific purpose and the recipient by accepting this drawing, assumes custody and control and agrees to take reasonable precautions; (a) that this drawing will not be copied and reproduced in whole or in part, or its contents revealed in any manner, or to any person except to meet the purpose for which it was delivered and (b) that any special features peculiar to this design will not be incorporated in other projects without the expressed written permission of Tyco Electronics Corporation.

REVISIONS			
EC	REV	DESCRIPTION	DATE
0S1Q-0400-04	A	NEW RELEASE	11/04/04



8. PART NUMBER INFORMATION

CONNECTOR	TYCO PART NUMBER	ELCON PART NUMBER	TERMINATION TYPE	PC TAIL LENGTH	RECOMMENDED MOUNTING BOARD	MATING BOARD
SOCKET	6650380-1	287-0032-12101	SOLDER TAIL (SHORT)	3.56 [.140] 2.54 [.100]	1.6 [.062] THICK	1.6 [.062] THICK
SOCKET	6650380-2	287-0032-12301	SOLDER TAIL (STANDARD)	5.08 [.200] 4.06 [.160]	3.2 [.125] OR THINNER	1.6 [.062] THICK

NOTES: UNLESS OTHERWISE SPECIFIED;

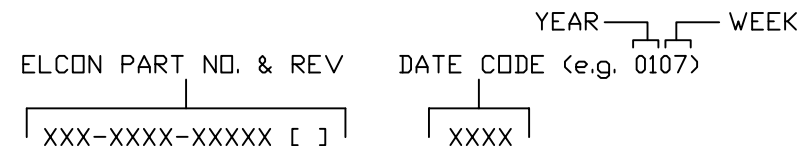
- PART NUMBER CHANGES AND OR DESIGN CHANGES AFFECTING ITEM INTERCHANGEABILITY REQUIRE PRIOR ELCON APPROVAL AND AUTHORIZATION BY REVISION TO THIS DRAWING.
 - MATERIALS:
INSULATORS: THERMOPLASTIC, GLASS REINFORCED, COLOR-BLACK, UL94V-0 FLAMMABILITY RATED.
CONTACTS: PHOSPHOR-BRONZE ALLOY.
 - FINISHES:
CONTACTS: SELECTIVE GOLD PLATED PER MIL-G-45204 TYPE II, GRADE C, CLASS 0. 000030" MIN. THK, OVER NICKEL PER QQ-N-290, CLASS 2, .000040" MIN. THICKNESS.
TERMINALS: TIN PLATED, MATTE FINISH, .000120" TO .000170" THICK.
- 4 SOCKETS ACCEPT 1.6 [.062] ± 10% THK PC BOARD.
- 5 EXAMPLE PCB CONFIGURATION SHOWING SEQUENCING.
- 6 THIS 2 X 2 SEGMENT CONFIGURATION SHOWN IS FOR REFERENCE ONLY. COMBINATION OF MULTIPLE NUMBERS OF 2 AND 3 SEGMENT MODULES COULD BE USED PER USER PREFERENCE. OVERALL COMBINATION SHOULD NOT EXCEED 8" IN LENGTH.
- 7 ITEMS PROVIDED TO THIS SPECIFICATION TO BE PERMANENTLY IDENTIFIED PER THE FOLLOWING IDENTIFIER:

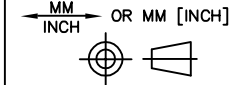

 THIRD ANGLE PROJECTION UNLESS OTHERWISE SPECIFIED DIMENSIONS ARE IN METRIC [INCHES] TOLERANCES ANGLES ± .5° DECIMALS .XX ± .25 [.010] .X ± .5 [.020]	DRAWN R. F. A.	DATE 11/04/04	 Tyco Electronics Corporation Menlo Park, Ca 94025		
	CHECKED		TITLE		
	APPROVED		SOCKET CONNECTOR, CROWN EDGE 4 POSN POWER, STRAIGHT, SOLDER PN: 287-0032-12101/287-0032-12301		
	APPROVED D. CHAU	11/04/04	SIZE B	DWG NUMBER C = 6650380	REV. A
DCA APPROVED M. ALIM		11/08/04	ACAD FILE NUMBER C6650380A.DWG		
			DWG SCALE 2=1	SH 1 OF 5	

This drawing involves proprietary design rights of Tyco Electronics Corporation, and all design, manufacture, reproduction, use and sale rights regarding the same are expressly reserved. It is submitted for a specific purpose and the recipient by accepting this drawing, assumes custody and control and agrees to take reasonable precautions; (a) that this drawing will not be copied and reproduced in whole or in part, or its contents revealed in any manner, or to any person except to meet the purpose for which it was delivered and (b) that any special features peculiar to this design will not be incorporated in other projects without the expressed written permission of Tyco Electronics Corporation.

REVISIONS			
EC	REV	DESCRIPTION	DATE
		SEE SHEET 1	

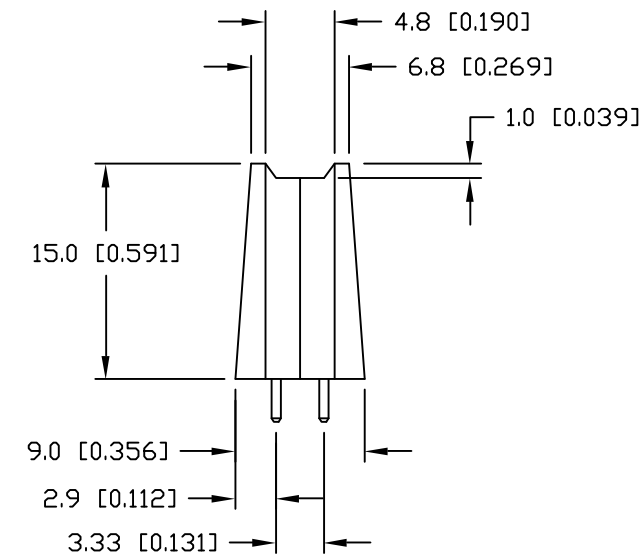
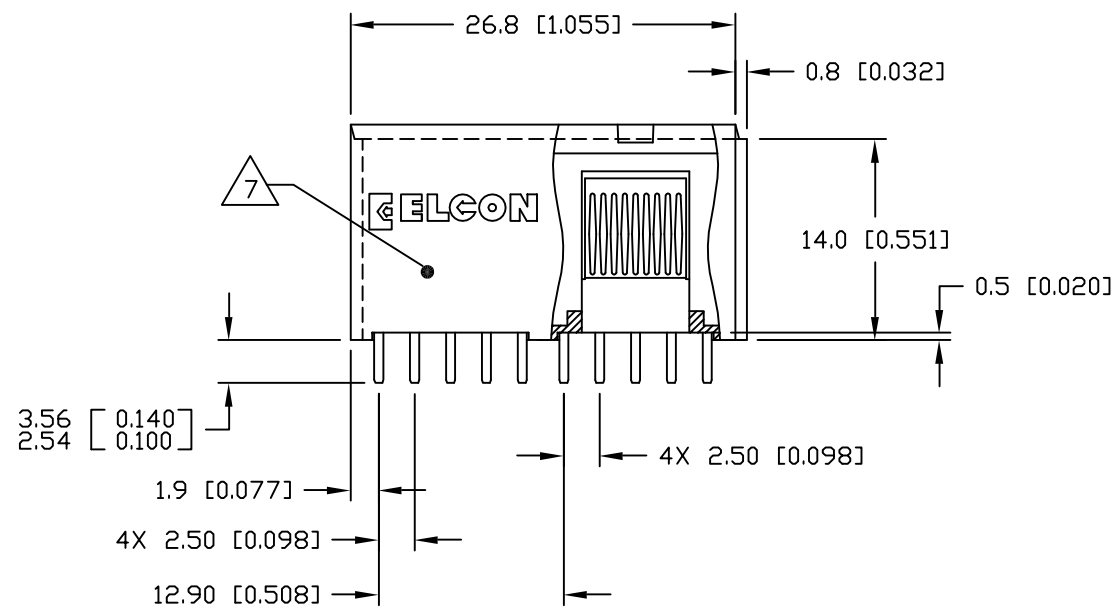
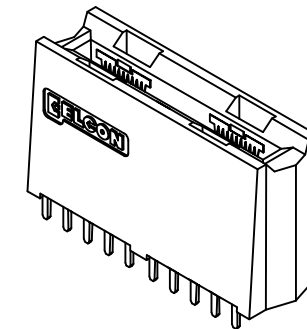
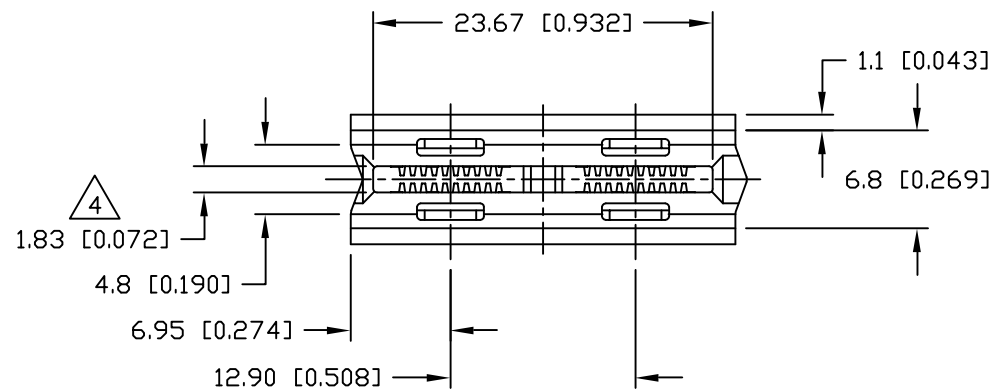

<p>THIRD ANGLE PROJECTION</p> <p>UNLESS OTHERWISE SPECIFIED DIMENSIONS ARE IN METRIC [INCHES]</p> <p>TOLERANCES</p> <p>ANGLES ± .5°</p> <p>DECIMALS</p> <p>.XX ± .25 [.010]</p> <p>.X ± .5 [.020]</p>	<p>MM OR MM [INCH]</p> <p>INCH</p>	<p>DRAWN</p> <p>R. F. A.</p>	<p>DATE</p> <p>11/04/04</p>	<p>tyco Tyco Electronics Corporation</p> <p>Electronics Menlo Park, Ca 94025</p> <p>ELCON</p>	
	<p>CHECKED</p>	<p>APPROVED</p>	<p>TITLE</p> <p>SOCKET CONNECTOR, CROWN EDGE 4 POSN POWER, STRAIGHT, SOLDER PN: 287-0032-12101</p>	<p>SIZE</p> <p>B</p>	
	<p>APPROVED</p> <p>D. CHAU</p>	<p>APPROVED</p> <p>M. ALIM</p>	<p>DATE</p> <p>11/04/04</p>	<p>DATE</p> <p>11/08/04</p>	<p>DWG NUMBER</p> <p>C = 6650380</p>
	<p>ACAD FILE NUMBER</p> <p>C6650380A.DWG</p>	<p>DWG SCALE</p> <p>2=1</p>	<p>SH 2 OF 5</p>	<p>REV.</p> <p>A</p>	

This drawing involves proprietary design rights of Tyco Electronics Corporation, and all design, manufacture, reproduction, use and sale rights regarding the same are expressly reserved. It is submitted for a specific purpose and the recipient by accepting this drawing, assumes custody and control and agrees to take reasonable precautions; (a) that this drawing will not be copied and reproduced in whole or in part, or its contents revealed in any manner, or to any person except to meet the purpose for which it was delivered and (b) that any special features peculiar to this design will not be incorporated in other projects without the expressed written permission of Tyco Electronics Corporation.

REVISIONS			
EC	REV	DESCRIPTION	DATE
		SEE SHEET 1	

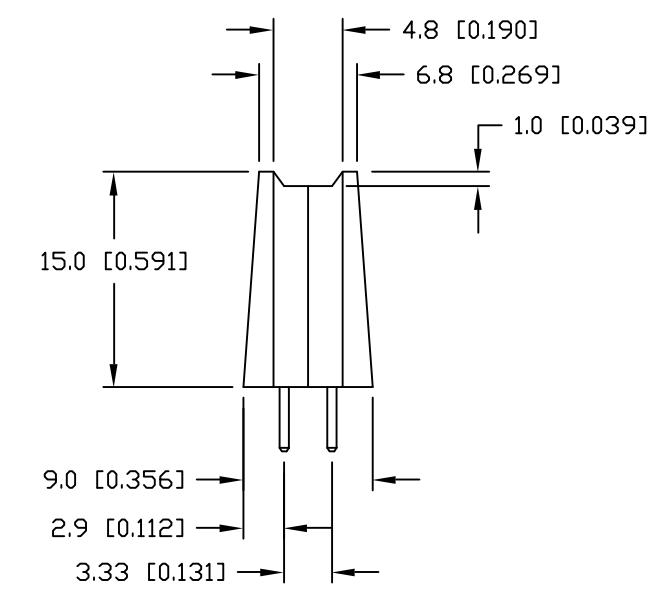
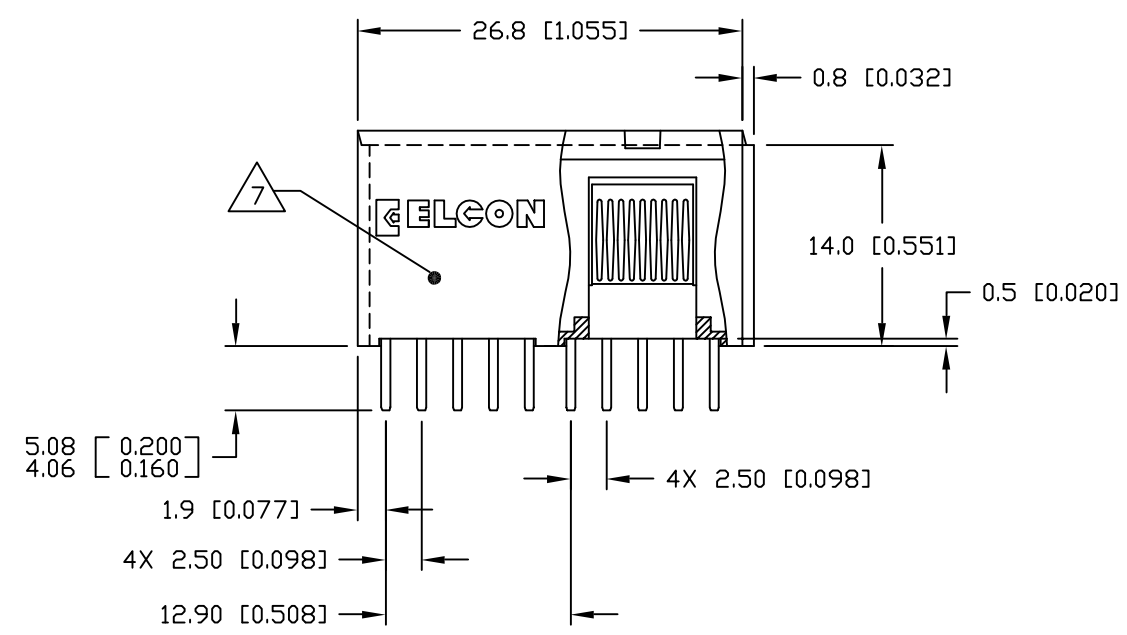
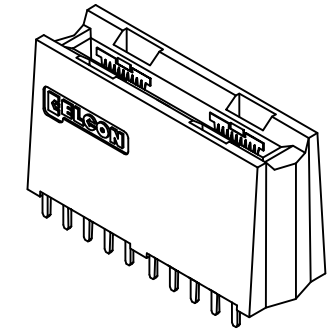
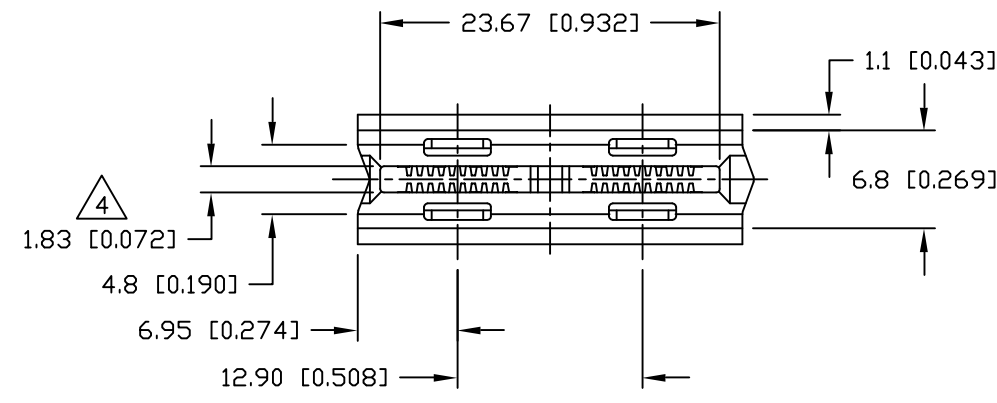

<p>THIRD ANGLE PROJECTION</p> <p>UNLESS OTHERWISE SPECIFIED DIMENSIONS ARE IN METRIC [INCHES]</p> <p>TOLERANCES</p> <p>ANGLES ± .5°</p> <p>DECIMALS</p> <p>.XX ± .25 [.010]</p> <p>.X ± .5 [.020]</p>	<p>DRAWN</p> <p>R. F. A.</p>	<p>DATE</p> <p>11/04/04</p>	<p>tyco Tyco Electronics Corporation Menlo Park, Ca 94025</p> <p>ELCON</p>	
	<p>CHECKED</p>			<p>TITLE</p> <p>SOCKET CONNECTOR, CROWN EDGE 4 POSN POWER, STRAIGHT, SOLDER PN: 287-0032-12301</p>
	<p>APPROVED</p>	<p>D. CHAU</p>	<p>11/04/04</p>	<p>SIZE DWG NUMBER</p> <p>B C = 6650380</p>
	<p>APPROVED</p>	<p>M. ALIM</p>	<p>11/08/04</p>	<p>REV.</p> <p>A</p>
<p>ACAD FILE NUMBER C6650380A.DWG</p>			<p>DWG SCALE 2=1 SH 3 OF 5</p>	

This drawing involves proprietary design rights of Tyco Electronics Corporation, and all design, manufacture, reproduction, use and sale rights regarding the same are expressly reserved. It is submitted for a specific purpose and the recipient by accepting this drawing, assumes custody and control and agrees to take reasonable precautions; (a) that this drawing will not be copied and reproduced in whole or in part, or its contents revealed in any manner, or to any person except to meet the purpose for which it was delivered and (b) that any special features peculiar to this design will not be incorporated in other projects without the expressed written permission of Tyco Electronics Corporation.

REVISIONS			
EC	REV	DESCRIPTION	DATE
		SEE SHEET 1	

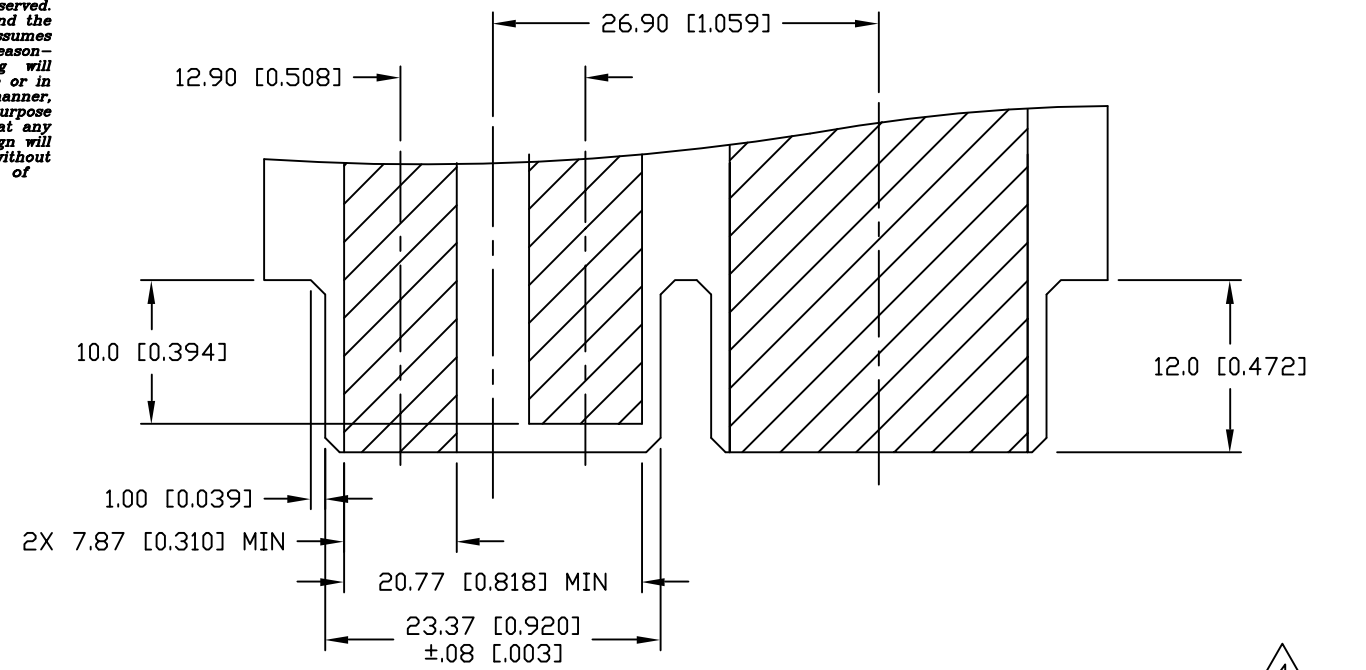

△ 6 DOUBLE SIDED P.C.B. CARD

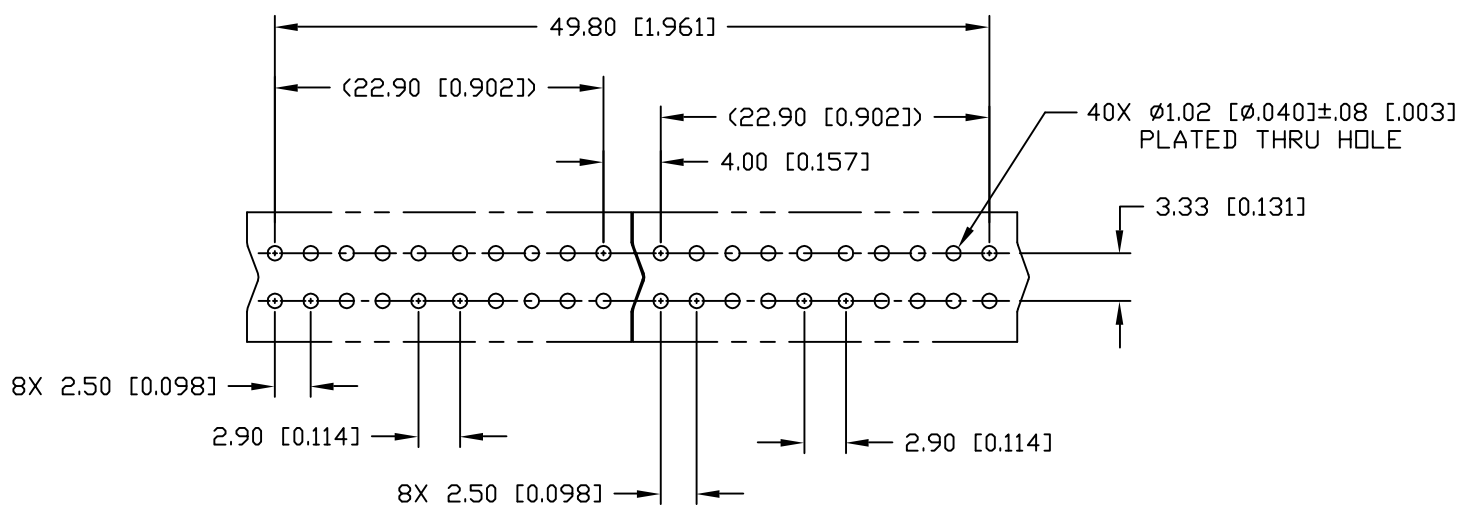
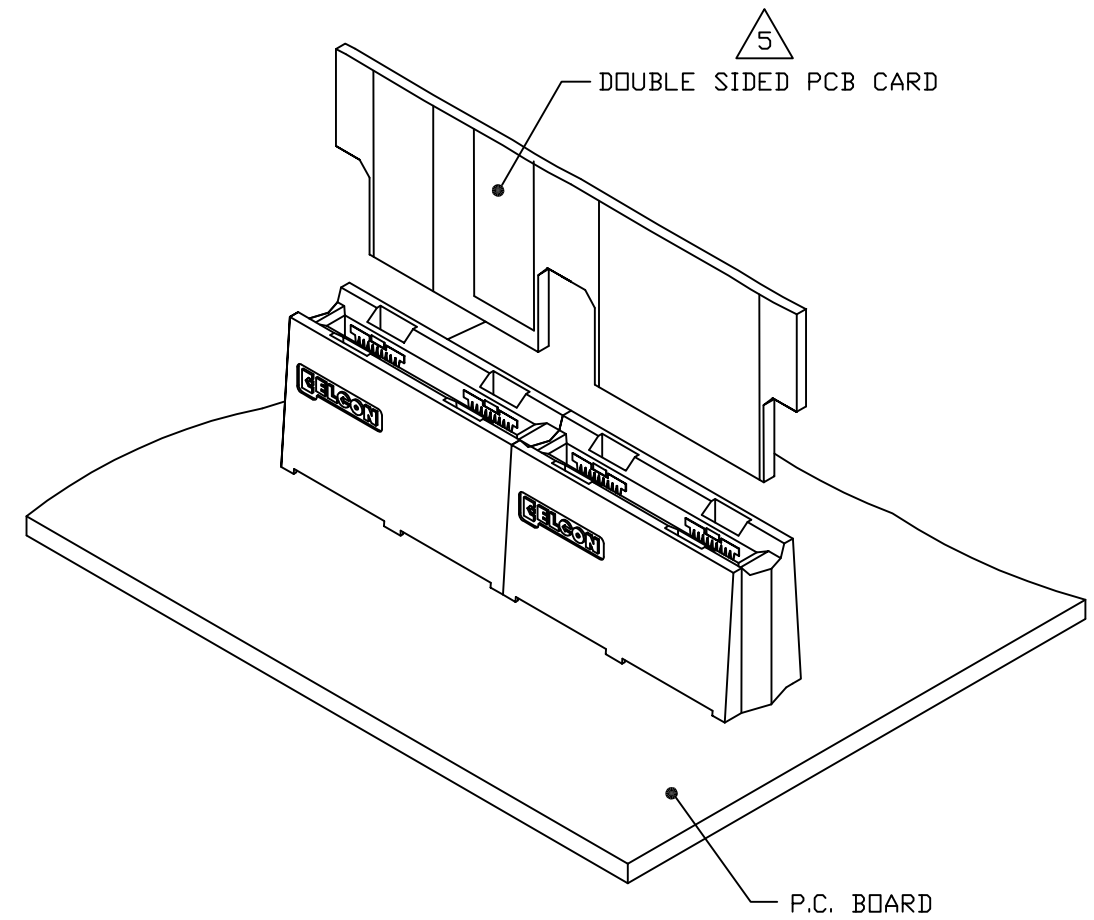

△ 6 RECOMMENDED P.C. BOARD LAYOUT

THIRD ANGLE PROJECTION UNLESS OTHERWISE SPECIFIED DIMENSIONS ARE IN METRIC [INCHES] TOLERANCES ANGLES ± .5° DECIMALS .XX ± .25 [.010] .X ± .5 [.020]	DRAWN	DATE	tyco Tyco Electronics Corporation Electronics Menlo Park, Ca 94025	ELCON	
	R. F. A.	11/04/04			
	CHECKED		TITLE		
	APPROVED		RECOMMENDED PCB LAYOUT PN: 287-0032-12101 PN: 287-0032-12301		
	D. CHAU	11/04/04	SIZE	DWG NUMBER	
	DCA APPROVED		B	C = 6650380	
	M. ALIM	11/08/04		REV. A	
	ACAD FILE NUMBER	C6650380A.DWG		DWG SCALE 2=1 SH 4 OF 5	

This drawing involves proprietary design rights of Tyco Electronics Corporation, and all design, manufacture, reproduction, use and sale rights regarding the same are expressly reserved. It is submitted for a specific purpose and the recipient by accepting this drawing, assumes custody and control and agrees to take reasonable precautions; (a) that this drawing will not be copied and reproduced in whole or in part, or its contents revealed in any manner, or to any person except to meet the purpose for which it was delivered and (b) that any special features peculiar to this design will not be incorporated in other projects without the expressed written permission of Tyco Electronics Corporation.

REVISIONS			
EC	REV	DESCRIPTION	DATE
		SEE SHEET 1	

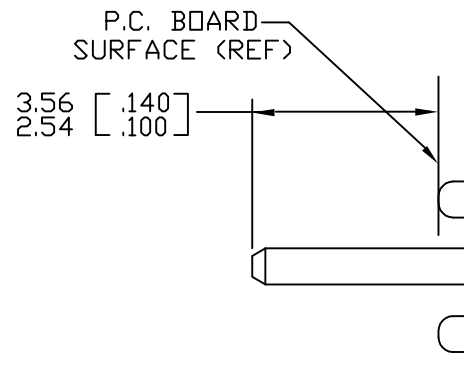

SOLDER PIN DETAIL

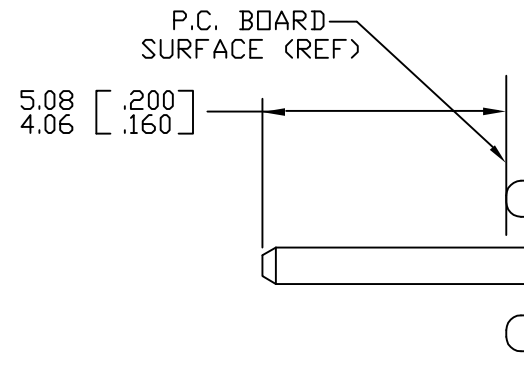

SOLDER PIN DETAIL

RECOMMENDED PRINTED CIRCUIT HOLE

FINISHED HOLE: $\phi 1.02$ [.040] $\pm .08$ [.003]
 DRILLED HOLE: $\phi 1.15$ [.0453] $\pm .013$ [.0005]
 COPPER PLATE: .025 [.0010] MINIMUM (PER SURFACE)
 TIN PLATE: .008 [.0003] MINIMUM (PER SURFACE)

<p>THIRD ANGLE PROJECTION</p> <p>UNLESS OTHERWISE SPECIFIED DIMENSIONS ARE IN METRIC [INCHES]</p> <p>TOLERANCES</p> <p>ANGLES $\pm .5^\circ$</p> <p>DECIMALS</p> <p>.XX $\pm .25$ [.010] .X $\pm .5$ [.020]</p>	<p>MM OR MM [INCH]</p> <p>INCH</p>	<p>DRAWN</p> <p>R. F. A.</p>	<p>DATE</p> <p>11/04/04</p>	<p>tyco Tyco Electronics Corporation Electronics Menlo Park, Ca 94025</p> <p>ELCON</p>	
	<p>CHECKED</p>		<p>TITLE</p> <p>SOCKET CONNECTOR, CROWN EDGE USER INFORMATION SOLDER TAIL TERMINATION</p>		
	<p>APPROVED</p>		<p>APPROVED</p> <p>D. CHAU</p> <p>11/04/04</p>	<p>SIZE</p> <p>B</p>	<p>DWG NUMBER</p> <p>C = 6650380</p>
	<p>APPROVED</p> <p>M. ALIM</p> <p>11/08/04</p>	<p>REV.</p> <p>A</p>	<p>ACAD FILE NUMBER</p> <p>C6650380A.DWG</p>	<p>DWG SCALE</p> <p>2=1</p>	<p>SH 5 OF 5</p>

X-ON Electronics

Largest Supplier of Electrical and Electronic Components

Click to view similar products for [Standard Card Edge Connectors](#) category:

Click to view products by [TE Connectivity](#) manufacturer:

Other Similar products are found below :

[6565204-6](#) [PKC-156](#) [1437274-4](#) [147889-1](#) [1489165-4](#) [EBT156-12B1X](#) [EBT15622B2X](#) [EBT156-22R2W](#) [1-582587-1](#) [1-582589-1](#) [2-6437275-9](#) [284-0102-12100](#) [306022901000000](#) [307-012-502-202](#) [307-024-526-201](#) [307-056-520-300](#) [307-080-526-208](#) [245-062-520-350](#) [287-0032-12101](#) [306-010-500-112](#) [306-028-525-102](#) [306-240-318](#) [307-036-502-202](#) [307-036-521-301](#) [307-072-526-202](#) [345-060-559-303](#) [368-004-520-201](#) [392-008-559-201](#) [534671-1](#) [5-530501-5](#) [341-240-317](#) [345-029-520-300](#) [345-030-500-301](#) [345-044-500-300](#) [345-220-058](#) [346-240-318](#) [357-030-526-201](#) [387-012-523-300](#) [395-044-520-300](#) [395-100-524-300](#) [50-12B-10](#) [50-6SN-5](#) [09-07-2032](#) [10035388-106LF](#) [10035388-802LF](#) [10122859-009LF](#) [10127905-B04B24BLF](#) [530555-1](#) [EBT156-15A2X](#) [2007209-1](#)