

Features

- Universal operating input voltage range 85 to 255 VAC
- RoHS lead-solder exemption compliant
- Class I equipment
- 1, 2, or 3 isolated outputs up to 64 V
- Input over- and undervoltage lockout
- Outputs: SELV, no load, overload, short-circuit proof, rectangular current limiting characteristic
- Adjustable output voltages with remote on/off
- Immunity according to IEC/EN 61000-4-2, -3, -4, -5, -6
- Emissions according to EN 55011/55022
- PCBs protected by lacquer
- Battery charger models available

Safety according to IEC/EN 60950-1, UL/CSA 60950-1



Description

The H Series of AC-DC converters represents a flexible range of power supplies for use in advanced industrial electronic systems. Features include high efficiency, reliability, and low output voltage noise.

The converter inputs are protected against surges and transients occurring at the source lines. An input over- and undervoltage lockout circuit disables the outputs, if the input voltage is outside the specified range. An inrush current limitation prevents circuit breakers and fuses from tripping at switch-on.

All outputs are open- and short-circuit proof, and are protected against overvoltages by means of built-in suppressor diodes. The outputs can be inhibited by a logic signal applied to the connector (pin 2). If the inhibit function is not used, pin 2 should be connected to pin 23 to enable the outputs.

LED indicators display the status of the converter and allow visual monitoring of the system at any time.

Full input to output, input to case, output to case, and output to

output isolation is provided. The converters are designed and built according to the international safety standards IEC/EN 60950-1 and UL/CSA 60950-1, and they are approved by the safety agencies TÜV and UL.

The case design allows operation at nominal load up to 50 °C in a free-air ambient temperature. If forced cooling is provided, the ambient temperature may exceed 50 °C but the case temperature should remain below 80 °C under all conditions.

A temperature sensor generates an inhibit signal, which disables the outputs, when the case temperature T_C exceeds the limit. The outputs automatically recover, when the temperature drops below the limit.

Two options are available to adapt the converters to individual applications (D, V).

The converters may either be plugged into 19" rack system according to IEC 60927-3 or be mounted onto a chassis or a plate.

Table of Contents

	Page		Page
Description	1	Immunity to Environmental Conditions	12
Model Selection	2	Mechanical Data	13
Functional Description	3	Safety and Installation Instructions	14
Electrical Input Data	4	Description of Options	15
Electrical Output Data	5	Accessories	20
Auxiliary Functions	9	EC Declaration of Conformity	21
Electromagnetic Compatibility (EMC)	11		

Model Selection

Non-standard input/output configurations or special custom adaptations are available on request. Table 1 provides an overview of the basic input and output configurations. More

than 1000 different types have been manufactured with different input/output configurations and customized specialities. Please consult Power-One for additional information.

Table 1a: Standard models

Output 1		Output 2		Output 3		Operating input voltage range and efficiency ¹		Options ²
$V_{O\ nom}$ [VDC]	$I_{O\ nom}$ [A]	$V_{O\ nom}$ [VDC]	$I_{O\ nom}$ [A]	V_{nom} [VDC]	$I_{O\ nom}$ [A]	$V_{i\ min} - V_{i\ max}$ 85 – 255 VAC, 47 – 63 Hz	η_{min} [%]	
5.1	11	-	-	-	-	LH1001-2R	74	D1 – D8, V2, V3
12	6	-	-	-	-	LH1301-2R	81	D1 – D8
15	4.5	-	-	-	-	LH1501-2R	83	D1 – D8
24	3	-	-	-	-	LH1601-2R	83	D1 – D8
48	1.5	-	-	-	-	LH1901-2R	83	D1 – D8
12	2	12	2	-	-	LH2320-2	81	D1 – D8
15	1.7	15	1.7	-	-	LH2540-2	81	D1 – D8
5.1	5	12	0.7	12	0.7	LH3020-2	78	D1 – D8, V2, V3
5.1	5	15	0.6	15	0.6	LH3040-2	78	D1 – D8, V2, V3

Table 1b: Battery charger models

Output				Operating input voltage range and efficiency ¹		Options ²
V_{Bat} [VDC]	$V_{O\ safe}$ ³ [VDC]	$V_{O\ max}$ [VDC]	$I_{O\ nom}$ [A]	$V_{i\ min} - V_{i\ max}$ 85 – 255 VAC, 47 – 63 Hz	η_{min} [%]	
12	12.84	14.15 – 14.6	5.0	LH1781-2R	81.5	D1 – D8
24	25.68	28.3 – 29.15	2.5	LH1782-2R	81.5	
36	38.52	42.45 – 43.72	1.67	LH1783-2R	83.5	
48	51.36	56.6 – 58.3	1.25	LH1784-2R	83.5	
60	64.2	70.75 – 72.87	1.0	LH1785-2R	83.5	

¹ Min. efficiency at $V_{i\ nom}$ and $I_{O\ nom}$. Typical values are approx. 2% better.

² Ask Power-One for availability!

³ Setting voltage with open R-input (battery chargers)

Part Number Description

L H 1 5 01 -2 R D3

Operating input range V_i :
 85 – 255 VAC, 47 – 63 Hz L

Series H

Number of outputs 1, 2, 3

Output 1, $V_{o1 \text{ nom}}$:
 5.1 V 0, 1, 2
 12 V 3
 15 V 4, 5
 24 V 6
 other voltages 7, 8
 48 V 9

 Single-output models (different specs.) 01 – 99

Outputs 2, 3: $V_{o2 \text{ nom}}$, $V_{o3 \text{ nom}}$:
 5.1 V 01 – 19
 12 V 20 – 39
 15 V 40 – 59
 24 V 60 – 69
 other voltages for multiple-output models 70 – 99

Ambient temperature range T_A :
 –10 to 50 °C -2
 customer-specific -0

Auxiliary functions and options:
 Output voltage control input (single-output models) R
 Save data signal (D1 – D8, to be specified) D¹
 ACFAIL signal (V2, V3, to be specified) V¹

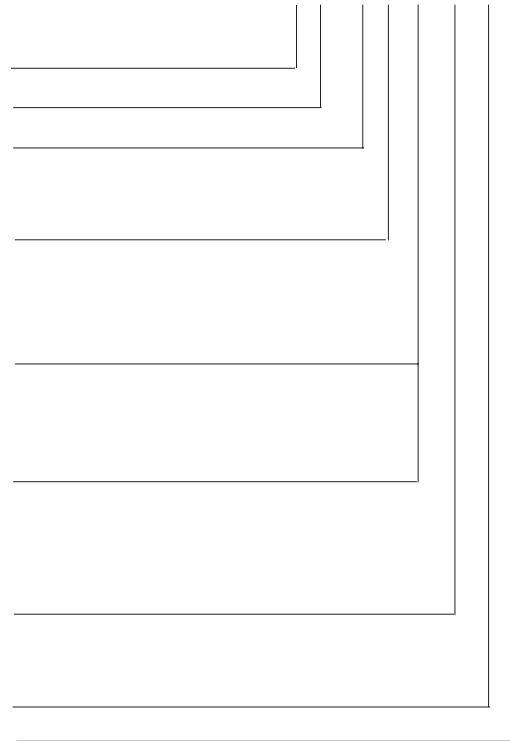

¹ Option D excludes option V and vice versa

Example: LH1501-2D3: AC-DC converter, operating input voltage range 85 – 255 VAC, providing one output with 15 V / 4.5 A, equipped with an output voltage adjust input (R), and undervoltage monitor D3.

Functional Description

The input voltage is fed via an input fuse, an input filter, and an inrush current limiter to the input capacitor. This capacitor sources a single-transistor forward converter. Each output is powered by a separate secondary winding of the main transformer. The resultant voltages are rectified and their ripples smoothed by a power choke and an output capacitor. The main control circuit senses the main output voltage V_{o1} and generates, with respect to the maximum admissible output currents, the control signal for the primary switching transistor. This signal is transferred to the primary side by a coupling transformer.

The auxiliary output voltages V_{o2} and V_{o3} are tracking. Each auxiliary output's current is sensed using a current transformer. If one of the outputs is driven into current limit, the other outputs will reduce their output voltages as well, because all output currents are controlled by the same main control circuit.

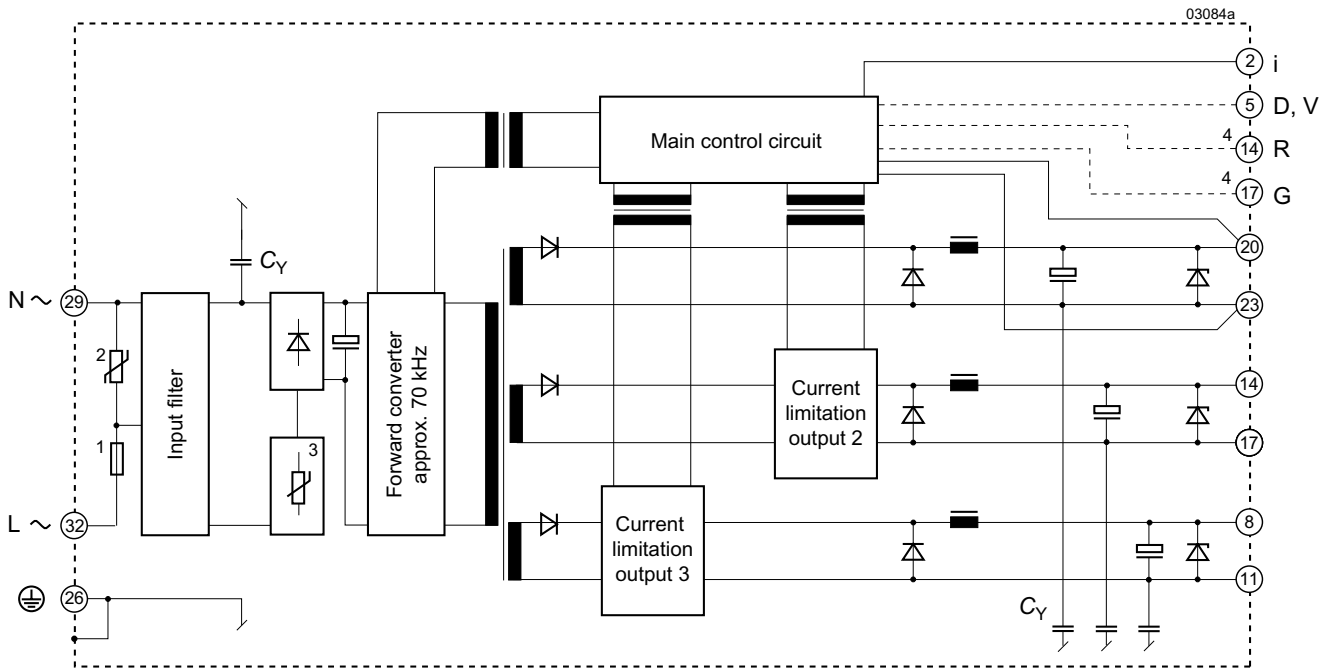

Fig. 1
Block diagram of a triple-output model.

- 1 Input fuse
- 2 Transient suppressor
- 3 Inrush current limiter (NTC)
- 4 Adjust input for single-output models with feature R.

Electrical Input Data

General conditions:

- $T_A = 25\text{ °C}$, unless T_C is specified.
- Connector pins 2 and 23 interconnected, R input not connected; with option P: $V_o = V_{o\text{ nom}}$

Table 2: Input data

Input			LM			Unit
Characteristics		Conditions	min	typ	max	
V_i	Operating input voltage	$I_o = 0 - I_{o\text{ nom}}$	85		255	VAC ¹
$V_{i\text{ nom}}$	Nominal input voltage	$T_C\text{ min} - T_C\text{ max}$		230		
I_i	Input current	$V_{i\text{ nom}}, I_o = I_{o\text{ nom}}^2$		0.44		A
P_{i0}	No-load input power: Single-output model Double-output model Triple-output model	$V_{i\text{ nom}}$ $I_{o1,2,3} = 0$		1 7 7	2.5 9 9	W
$P_{i\text{ inh}}$	Idle input power	inhibit mode			2.5	
$I_{i\text{ nr p}}^5$	Peak inrush current	$V_i = V_{i\text{ max}}$ $R_S = 0\ \Omega^3$ $T_C = 25\text{ °C}$			42 ⁴	A
$t_{i\text{ nr r}}$	Rise time			300		μs
$t_{i\text{ nr h}}$	Time to half-value			1600		
R_i	Input resistance	$T_C = 25\text{ °C}$	800			m Ω
R_{NTC}	NTC resistance		8000 ⁴			
C_i	Input capacitance		140	270		μF
$V_{i\text{ abs}}$	Input voltage limits without any damage		0		284	VAC

- ¹ Frequency 47 – 63 Hz
- ² With multiple-output models, the same condition for each output applies.
- ³ R_S = source resistance.
- ⁴ Value for initial switch-on cycle.
- ⁵ $I_{i\text{ nr p}} = V_i / (R_S + R_i + R_{\text{NTC}})$; see *Inrush Current*.

Input Fuse

A slow-blow fuse (Schurter SPT 2.5 A, 250 V, size 5 × 20 mm) mounted inside of the converter protects against severe defects. The fuse is not accessible by the user.

The fuse and a VDR form together with the input filter an effective protection against high input transients.

Input Under-/Overvoltage Lockout

If the input voltage is below approx. 60 VAC or exceeds approx. 280 VAC, an internally generated inhibit signal disables the output(s). When checking this function the absolute maximum input voltage rating $V_{i abs}$ must be carefully considered (see table *Input data*).

Note: When V_i is between $V_{i min}$ and the undervoltage lockout level, the output voltage may be below the value defined in table *Output data*.

Inrush Current

The converters incorporate an NTC resistor in the input line, which at initial switch-on cycle limits the peak inrush current, in

order to prevent the connectors and switching devices from damage. Subsequent switch-on cycles within a short interval will cause an increase of the peak inrush current due to the warming-up of the NTC resistor.

The inrush current at switch-on can be calculated as follows:

$$I_{inr p} = \sqrt{2} \cdot V_{i rms} / (R_s + R_i + R_{NTC})$$

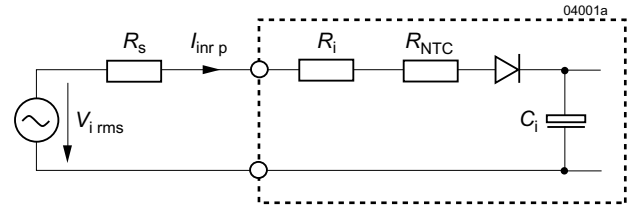

Fig. 2
Equivalent circuit diagram for input impedance

Electrical Output Data

General conditions

- $T_A = 25 \text{ }^\circ\text{C}$, unless T_C is specified.
- Connector pins 2 and 23 interconnected, R input not connected.

Table 3a: Output data of single-output models

Output		$V_{o nom}$	5.1 V		12 V		15 V		24 V		48 V		Unit	
Characteristics		Conditions	min	typ	max	min	typ	max	min	typ	max	min	typ	max
V_o	Output voltage	$V_{i nom}, I_{o nom}$	5.0	5.20	11.76	12.24	14.70	15.30	23.52	24.48	47.04	48.96	V	
$V_{o p}$	Output overvoltage protection ¹		7.5		21		25		41		85			
$I_{o nom}$	Output current	$V_{i min} - V_{i max}$	0	11	0	6	0	4.5	0	3	0	1.5	A	
$I_{o L}$	Output current limit	$T_C min - T_C max$	11.44		6.24		4.68		3.12		1.56			
v_o	Output voltage noise	Switch. freq.	$V_{i nom}, I_{o nom}$		30 50		60 100		50 80		50 80		mV _{pp}	
		Total	IEC/EN 61204 BW = 20 MHz		60 120		40 80		40 80		-			
$\Delta V_{o V}$	Static line regulation	$V_{i min} - V_{i nom}$ $V_{i nom} - V_{i max}$ $I_{o nom}$	±50		±100		±100		±150		±150		mV	
$\Delta V_{o I}$	Static load regulation	$V_{i nom}, I_{o nom} - 0$	50		150		150		150		150			
$v_{o d}$	Dynamic load regulation ²	Voltage deviation	$V_{i nom}$		±220		±400		±200		±200		±150	
t_d		Recovery time	IEC/EN 61204		100		80		80		80		120	µs
α_{v_o}	Temperature coefficient	$V_{i min} - V_{i max}$ $0 - I_{o nom}$	±0.02		±0.02		±0.02		±0.02		±0.02		%/K	
			±1.0		±2.4		±3.0		±4.8		±9.6		mV/K	

¹ By suppressor diode

² See fig. 4 *Dynamic load regulation*.

Table 3b: Output data of double-output models. Same general conditions as per table 3a

Output		$V_{o\ nom}$	2 × 12 V			2 × 15 V			Unit		
Characteristics Conditions			Output 1		Output 2		Output 1		Output 2		
			min	typ	max	min	typ	max	min	typ	max
V_o	Output voltage	$V_{i\ nom}, I_{o\ nom}$	11.76	12.24	11.4	12.6	14.7	15.3	14.25	15.75	V
		$V_{i\ nom}, I_{o2} = 0$				13.8				17.25	
V_{op}	Output overvoltage protection		21		25		25		31		
$I_{o\ nom}$	Output current	$V_{i\ min} - V_{i\ max}$ $T_{C\ min} - T_{C\ max}$	0	2	0	2	0	1.7	0	1.7	A
I_{oL}	Output current limit		2.08		2.08		1.77		1.77		
v_o	Output voltage noise ¹	Switch. freq.	15 30		20 40		15 30		20 40		mV _{pp}
		Total	50 150		50 150		40 150		40 150		
ΔV_{oV}	Static line regulation	$V_{i\ min} - V_{i\ nom}$ $V_{i\ nom} - V_{i\ max}$ $I_{o\ nom}$	±50		±80		±60		±180		mV
ΔV_{oI}	Static load regulation	$V_{i\ nom}, I_{o\ nom} - 0^3$	50		2		60		2		
α_{Vo}	Temperature coefficient $\Delta V_o/\Delta T_C$	$V_{i\ min} - V_{i\ max}$ $0 - I_{o\ nom}$	±2.4				±3.0				mV/K

Table 3c: Output data of triple-output models. Same general conditions as per table 3a

Output		$V_{o\ nom}$	5.1 V, 2 × 12 V			5.1 V, 2 × 15 V			Unit		
Characteristics Conditions			Output 1		Output 2		Output 1		Output 2		
			min	typ	max	min	typ	max	min	typ	max
V_o	Output voltage	$V_{i\ nom}, I_{o\ nom}$	5.0	5.2	11.4	12.6	5.0	5.2	14.25	15.75	V
		$V_{i\ nom}, I_{o2} = I_{o3} = 0$				13.8				17.25	
V_{op}	Output overvoltage protection		7.5		25		7.5		31		
$I_{o\ nom}$	Output current	$V_{i\ min} - V_{i\ max}$ $T_{C\ min} - T_{C\ max}$	0	5	0	0.7	0	5	0	0.6	A
I_{oL}	Output current limit		5.2		0.73		5.2		0.62		
v_o	Output voltage noise ¹	Switch. freq.	15 30		10 20		15 30		10 20		mV _{pp}
		Total	30 150		50 150		40 150		40 150		
ΔV_{oV}	Static line regulation	$V_{i\ min} - V_{i\ nom}$ $V_{i\ nom} - V_{i\ max}$ $I_{o\ nom}$	±30		±150		±30		±150		mV
ΔV_{oI}	Static load regulation	$V_{i\ nom}, I_{o\ nom} - 0^3$	25		2		250		2		
α_{Vo}	Temperature coefficient $\Delta V_o/\Delta T_C$	$V_{i\ min} - V_{i\ max}$ $0 - I_{o\ nom}$	±1.0				±1.0				mV/K

¹ Measured with a clamp according to IEC 61204

² See Voltage regulation of tracking outputs

³ Condition for the specified output; other outputs loaded with $I_{o\ nom}$

Output Characteristic and Protection

Each output is protected by a suppressor diode, which under a worst case condition may become a short circuit. The suppressor diodes are not designed to withstand externally applied overvoltages. Overload at any of the outputs will cause a shutdown of all outputs. A red LED indicates the overload condition of the respective output.

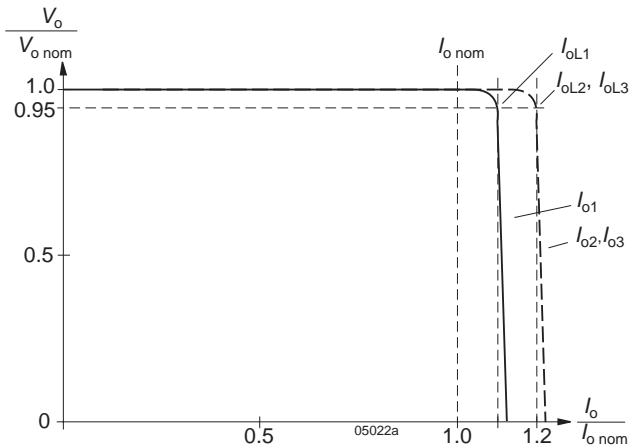

Fig. 3
Typical main output voltage V_{o1} versus current I_{o1}

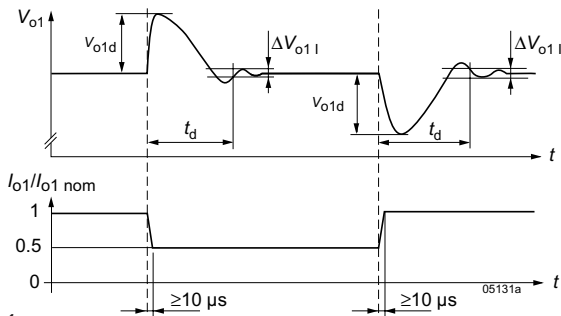

Fig. 4
Dynamic load regulation of V_{o1} versus load change.

Regulation of Multiple-Output Models

Output 1 is under normal conditions regulated to $V_{o1,nom}$,

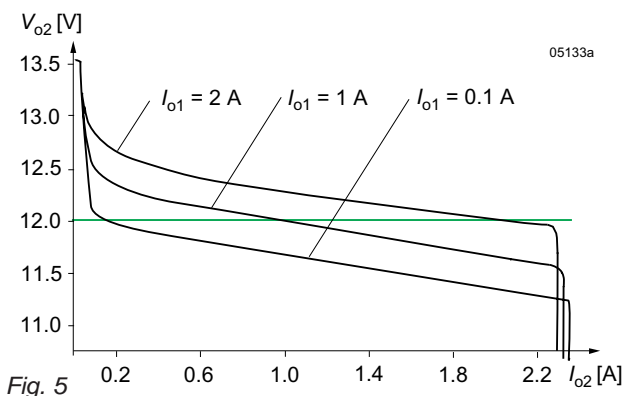

Fig. 5
Static load regulation V_{o2} versus I_{o1} (LH2320-2)

regardless of the output current. The voltage of the tracking outputs 2 and 3 depends upon their load and the load on output 1; see fig. 5 to 8.

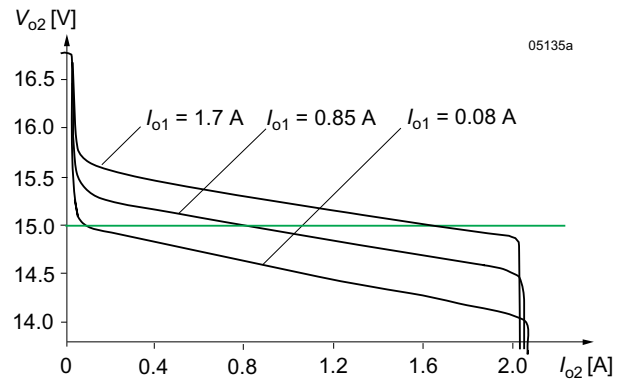

Fig. 6
Static load regulation V_{o2} versus I_{o1} (LH2540-2)

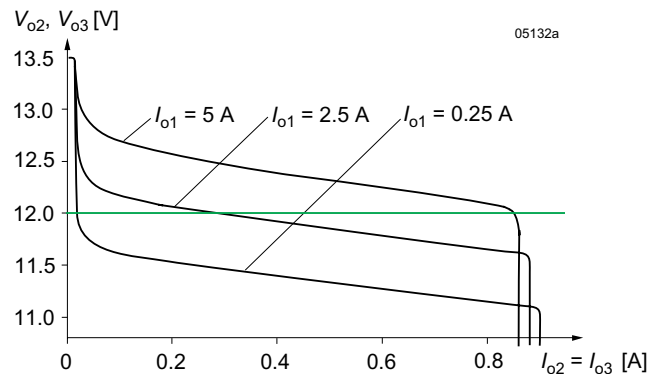

Fig. 7
Static load regulation V_{o2} and V_{o3} versus I_{o1} (LH3020-2, $I_{o2} = I_{o3}$)

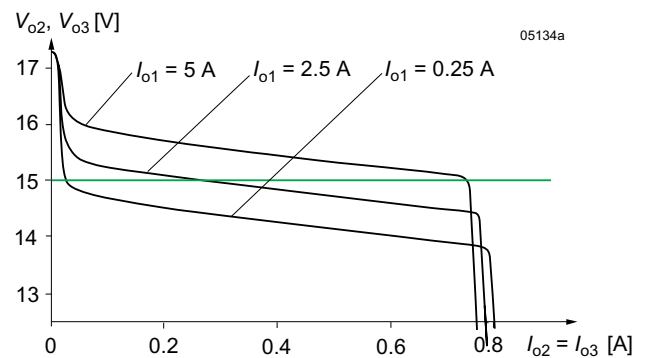

Fig. 8
Static load regulation V_{o2} and V_{o3} versus I_{o1} (LH3040-2, $I_{o2} = I_{o3}$)

Thermal Considerations and Protection

If a converter is located in free, quasi-stationary air (convection cooling) at the indicated maximum ambient temperature $T_{A \max}$ (see table *Temperature specifications*) and is operated at its nominal input voltage and output power, the temperature measured at the measuring point of case temperature T_C (see *Mechanical Data*) will approach the indicated value $T_{C \max}$ after the warm-up phase. However, the relationship between T_A and T_C depends heavily on the conditions of operation and integration into a system. The thermal conditions are influenced by input voltage, output current, airflow, and temperature of surrounding components and surfaces. $T_{A \max}$ is therefore, contrary to $T_{C \max}$, an indicative value only.

Caution: The installer must ensure that under all operating conditions T_C remains within the limits stated in the table *Temperature specifications*.

Notes: Sufficient forced cooling or an additional heat sink allow T_A to pass over 50 °C, if $T_{C \max}$ is not exceeded.

At an ambient temperature T_A of 65 °C with only convection cooling, the maximum permissible current for each output is approx. 50% of its nominal value; see fig. 9 .

A temperature sensor generates an internal inhibit signal disabling the outputs, when the case temperature exceeds $T_{C \max}$. The outputs automatically recover, when the temperature drops below this limit.

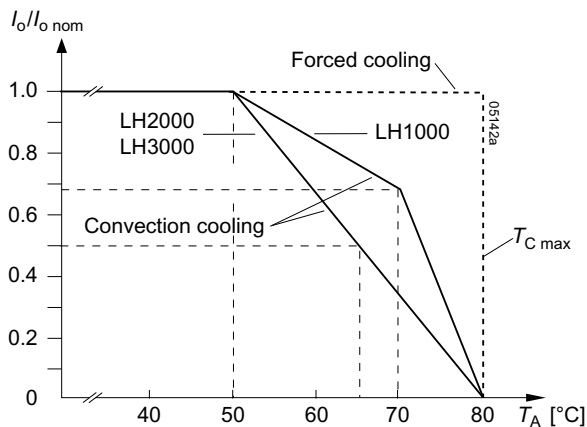

Fig. 9
Output current derating versus temperature

Parallel and Series Connection

Main outputs of equal nominal voltage can be connected in parallel. It is important to assure that the main output of a multiple-output converter is forced to supply a minimum current of 10% of $I_{o,nom}$ to enable correct operation of its own auxiliary outputs.

In parallel operation, one or more of the main outputs may operate continuously in current limitation, causing an increase

of the case temperature T_C . Consequently, a reduction of the max. ambient temperature by 10 K is recommended.

Both outputs of a **double-output converter** may be connected in parallel without any restriction.

Note: If output 2 of a double-output converter is not used, we recommend to connect it in parallel with the main output.

Output 2 and output 3 of a **triple-output converter** may be connected in parallel without any restriction.

Note: If the output 2 or 3 of a triple-output converter is not used, we recommend to connect it in parallel with the other auxiliary output.

Main or auxiliary outputs can be connected in series with any other output of the same or another converter. In series connection, the maximum output current is limited by the lowest current limit. Output ripple and regulation values are added. Connection wiring should be kept as short as possible.

If output terminals are connected together in order to establish multi-voltage configurations, e.g., +5.1 V, ±12 V etc., the common-ground connecting point should be as close as possible to the connector of the converter in order to avoid excessive output ripple voltages.

Auxiliary outputs of different converters should not be connected in parallel!

Auxiliary Functions

i Inhibit

The outputs of the converters may be enabled or disabled by means of a logic signal (TTL, CMOS, etc.) applied between the inhibit input *i* and the negative pin of output 1 (*Vo1-*). In systems with several converters, this feature can be used, for example, to control the activation sequence of the converters. If the inhibit function is not required, connect the inhibit pin 2 to pin 23 to enable the outputs (active low logic, fail safe). The response times are specified in fig. 12.

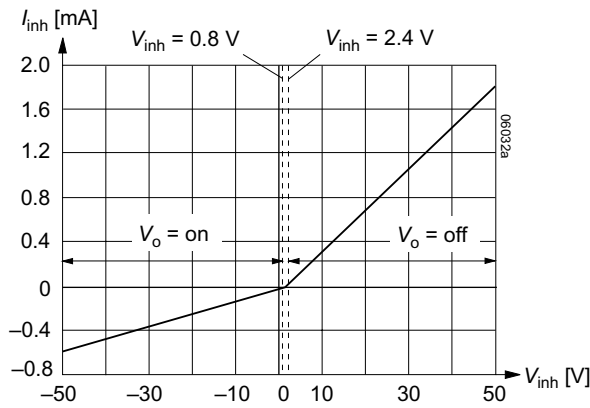

Fig. 10
Typical inhibit current I_{inh} versus inhibit voltage V_{inh}

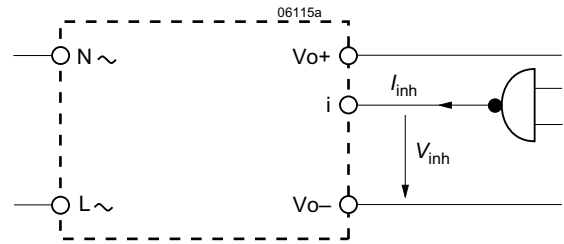

Fig. 11
Definition of V_{inh} and I_{inh} .

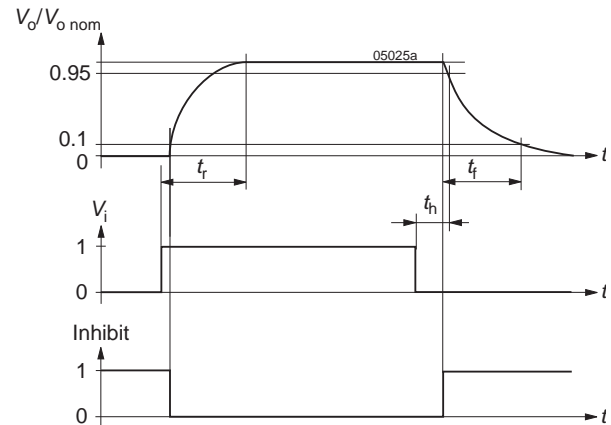

Fig. 12
Output response as a function of V_i or inhibit control

Table 4: Inhibit data

Characteristics		Conditions	min	typ	max	Unit
V_{inh}	Inhibit input voltage to keep output voltage	$V_o = on$	-50		0.8	V
		$V_o = off$	2.4		50	
I_{inh}	Inhibit current	$V_{inh} = 0$	-60	-100	-220	μA

Table 5: Output response time t_r and t_f (see fig. 4). Values not applicable for models equipped with option E.

Type of converter	t_r at $P_o = 0$ and t_f at $P_o = P_{o,nom}$		t_r and t_f at $P_o = \frac{3}{4} P_{o,nom}$		t_r at $P_o = P_{o,nom}$		Unit
	typ	max	typ	max	typ	max	
LH1001-2R	3	17	3	17	5	25	ms
LH1301-2R	5	25	8	30	10	40	
LH1501-2R	3	17	5	25	15	50	
LH1601-2R	8	30	15	45	20	70	
LH1901-2R	35	100	50	150	85	230	
LH2320-9	10	40	15	50	25	80	
LH2540-9	8	30	20	40	20	60	
LH3020-9	30	85	45	130	75	210	
LH3040-9	20	70	30	90	50	150	

Conditions:

R input not connected. For multiple-output models the figures indicated in the table relate to the output, which reacts slowest. All outputs are resistively loaded. Variation of the input voltage within $V_{i,min} - V_{i,max}$ does not influence the values considerably.

R Output Voltage Adjustment

As a standard feature, single-output models offer an adjustable output voltage identified by letter R in the type designation.

Note: With open R input, $V_o = V_{o\ nom}$.

The output voltage V_o can either be adjusted by an external voltage (V_{ext}) or by an external resistor (R_{ext1} or R_{ext2}). The adjustment range is approximative 0 – 110% of $V_{o\ nom}$. For output voltages $V_o > V_{o\ nom}$, the minimum input voltage $V_{i\ min}$ specified in *Electrical Input Data* increases proportionally to $V_o/V_{o\ nom}$.

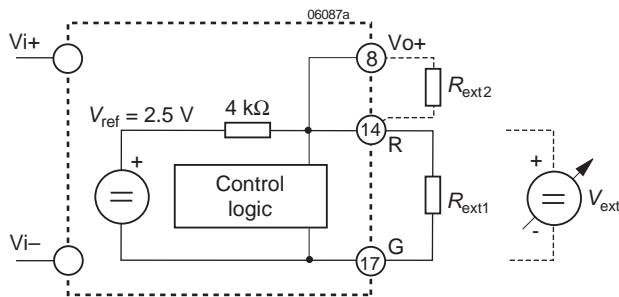

Fig. 13
Output voltage adjustment

- a) Adjustment by means of an external resistor R_{ext} :
Depending upon the value of the required output voltage, the resistor shall be connected:
either: Between the R and G pin to achieve an output voltage adjustment range of $V_o \approx 0$ to 100% of $V_{o\ nom}$.

$$R_{ext1} \approx 4\text{ k}\Omega \cdot \frac{V_o}{V_{o\ nom} - V_o}$$

- or:** Between the R pin and Vo+ to achieve an output voltage range of $V_o \approx 100$ to 110% of $V_{o\ nom}$.

$$R_{ext2} \approx 4\text{ k}\Omega \cdot \frac{(V_o - 2.5\text{ V})}{2.5\text{ V} \cdot (V_o/V_{o\ nom} - 1)}$$

Caution: To prevent damage, R_{ext2} should never be less than 47 k Ω .

Note: R inputs of n converters with paralleled outputs may be paralleled too, but if only one external resistor is used, its value should be R_{ext1}/n or R_{ext2}/n respectively.

- b) Adjustment by means of an external control voltage V_{ext} between G and R pin:
The control voltage range is 0 to 2.75 V and allows for adjustment in the range of $V_o \approx 0$ to 110% of $V_{o\ nom}$.

$$V_{ext} \approx \frac{V_o \cdot 2.5\text{ V}}{V_{o\ nom}}$$

Caution: The external control voltage should be in the range 0 to +3 V to prevent the converter from damage.

Table 6a: R_{ext1} for $V_o < V_{o\ nom}$ (conditions: $V_{i\ nom}$, $I_{o\ nom}$, rounded up to resistor values E 96, R_{ext2} is not fitted)

$V_{o\ nom} = 5.1\text{ V}$		$V_{o\ nom} = 12\text{ V}$		$V_{o\ nom} = 15\text{ V}$		$V_{o\ nom} = 24\text{ V}$		$V_{o\ nom} = 48\text{ V}$	
V_o [V]	R_{ext1} [k Ω]	V_o [V]	R_{ext1} [k Ω]	V_o [V]	R_{ext1} [k Ω]	V_o [V]	R_{ext1} [k Ω]	V_o [V]	R_{ext1} [k Ω]
0.5	0.432	2.0	0.806	2.0	0.619	4.0	0.806	8.0	0.806
1.0	0.976	3.0	1.33	4.0	1.47	6.0	1.33	12.0	1.33
1.5	1.65	4.0	2.0	6.0	2.67	8.0	2.0	16.0	2.0
2.0	2.61	5.0	2.87	8.0	4.53	10.0	2.87	20.0	2.87
2.5	3.83	6.0	4.02	9.0	6.04	12.0	4.02	24.0	4.02
3.0	5.76	7.0	5.62	10.0	8.06	14.0	5.62	28.0	5.62
3.5	8.66	8.0	8.06	11.0	11.0	16.0	8.06	32.0	8.06
4.0	14.7	9.0	12.1	12.0	16.2	18.0	12.1	36.0	12.1
4.5	30.1	10.0	20.0	13.0	26.1	20.0	20.0	40.0	20.0
5.0	200.0	11.0	44.2	14.0	56.2	22.0	44.2	44.0	44.2

Table 6b: R_{ext2} for $V_o > V_{o\ nom}$ (conditions: $V_{i\ nom}$, $I_{o\ nom}$, rounded up to resistor values E 96, R_{ext1} is not fitted)

$V_{o\ nom} = 5.1\text{ V}$		$V_{o\ nom} = 12\text{ V}$		$V_{o\ nom} = 15\text{ V}$		$V_{o\ nom} = 24\text{ V}$		$V_{o\ nom} = 48\text{ V}$	
V_o [V]	R_{ext2} [k Ω]	V_o [V]	R_{ext2} [k Ω]	V_o [V]	R_{ext2} [k Ω]	V_o [V]	R_{ext2} [k Ω]	V_o [V]	R_{ext2} [k Ω]
5.15	464	12.1	1780	15.2	1470	24.25	3160	48.5	6810
5.20	215	12.2	909	15.4	750	24.50	1620	49.0	3480
5.25	147	12.3	619	15.6	511	24.75	1100	49.5	2370
5.30	110	12.4	464	15.8	383	25.00	825	50.0	1780
5.35	90.9	12.5	383	16.0	332	25.25	715	50.5	1470
5.40	78.7	12.6	316	16.2	274	25.50	590	51.0	1270
5.45	68.1	12.7	274	16.4	237	25.75	511	51.5	1100
5.50	61.9	12.8	249	16.5	226	26.00	453	52.0	953
		13.0	200			26.25	402	52.5	845
		13.2	169			26.40	383	52.8	806

Display Status of LEDs

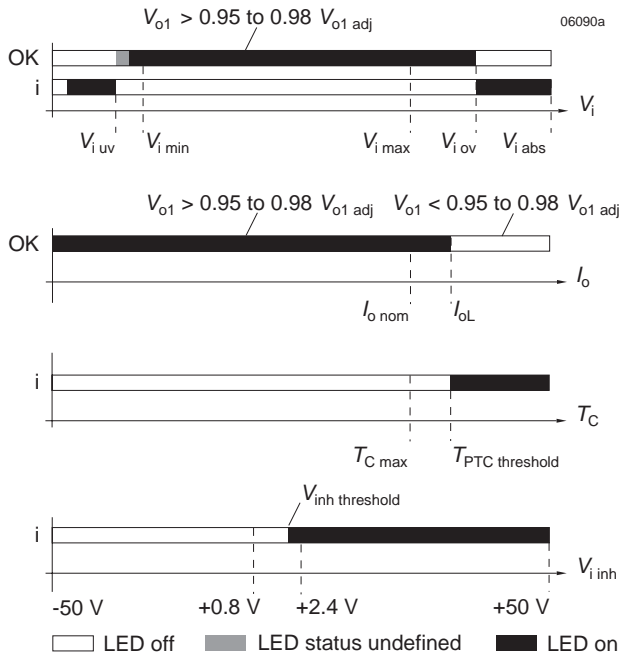

LEDs "OK" and "i" status versus input voltage V_i

Conditions: $I_o \leq I_{o\ nom}$, $T_C \leq T_{C\ max}$, $V_{inh} \leq 0.8\ V$

LED "OK" and "i_L" status versus output current I_o

Conditions: $V_i\ min - V_i\ max$, $T_C \leq T_{C\ max}$, $V_{inh} \leq 0.8\ V$

LED "i" versus case temperature

Conditions: $V_i\ min - V_i\ max$, $I_o \leq I_{o\ nom}$, $V_{inh} \leq 0.8\ V$

LED "i" versus V_{inh}

Conditions: $V_i\ min - V_i\ max$, $I_o \leq I_{o\ nom}$, $T_C \leq T_{C\ max}$

Fig. 14

Status of LEDs.

$V_{i\ uv}$ = undervoltage lockout, $V_{i\ ov}$ = overvoltage lockout

Electromagnetic Compatibility (EMC)

A metal oxide VDR (depending upon converter model) together with an input fuse and an input filter form an effective

protection against high input transient voltages, which typically occur in most installations, but especially in battery-driven mobile applications. The H series has been successfully tested to the following specifications:

Electromagnetic Immunity

Table 7: Immunity type tests

Phenomenon	Standard	Level	Coupling mode ²	Value applied	Waveform	Source imped.	Test procedure	In oper.	Per-form. ³
Electrostatic discharge (to case)	IEC/EN 61000-4-2	2	contact discharge	4000 V _p	1/50 ns	330 Ω	10 positive and 10 negative discharges	yes	A
Electromagnetic field	IEC/EN 61000-4-3	x	antenna	20 V/m	AM 80% 1 kHz	n.a.	26 to 1000 MHz	yes	A ¹
Electrical fast transient/burst	IEC/EN 61000-4-4	1	direct, i/c, +i/-i	500 V _p	bursts of 5/50 ns 2.5/5 kHz over 15 ms; burst period: 300 ms	50 Ω	60 s positive 60 s negative transients per coupling mode	yes	
Surge	IEC/EN 61000-4-5	1	i/c	500 V _p	1.2/50 μs	12 Ω	5 pos. and 5 neg. surges per	yes	A
		1	+i/-i	500 V _p		2 Ω			

¹ For converters with 3 output voltages, temporary deviation from specs possible

² i = input, o = output, c = case

³ A = Normal operation, no deviation from specifications, B = Normal operation, temporary deviation from specs possible

Electromagnetic Emissions

Table 8: Emissions at $V_{i\text{ nom}}$ and $I_{o\text{ nom}}$

Series	IEC/EN 55022	
	≤ 30 MHz	≥ 30 MHz
LH	<A	<B

Immunity to Environmental Conditions

Table 9: Mechanical and climatic stress

Test method	Standard	Test conditions	Status
Cab	Damp heat steady state IEC/EN 60068-2-78 MIL-STD-810D section 507.2	Temperature: 40 ±2 °C Relative humidity: 93 +2/-3 % Duration: 21 days	Converter not operating
Ea	Shock (half-sinusoidal) IEC/EN 60068-2-27 MIL-STD-810D section 516.3	Acceleration amplitude: 15 g _n = 147 m/s ² Bump duration: 6 ms Number of bumps: 18 (3 each direction)	Converter operating
Eb	Bump (half-sinusoidal) IEC/EN 60068-2-29 MIL-STD-810D section 516.3	Acceleration amplitude: 10 g _n = 98 m/s ² Bump duration: 16 ms Number of bumps: 6000 (1000 each direction)	Converter operating
Fc	Vibration (sinusoidal) IEC/EN/DIN EN 60068-2-6 MIL-STD-810D section 514.3	Acceleration amplitude: 0.15 mm (10 – 60 Hz) 2 g _n = 20 m/s ² (60 – 150 Hz) Frequency (1 Oct/min): 10 – 150 Hz Test duration: 3.75 h (1.25 h each axis)	Converter operating

Temperatures

Table 10: Temperature specifications, values given are for an air pressure of 800 – 1200 hPa (800 – 1200 mbar)

Temperature		Standard -2		
Characteristics	Conditions	min	max	Unit
T_A Ambient temperature	Operational	-10	50 ¹	°C
T_C Case temperature		-10	80	
T_S Storage temperature	Not operational	-25	100	

¹ Single output models up to 71 °C with derating.

Reliability

Table 11: MTBF

Values at specified Case Temperature	Model	Ground benign 40 °C	Unit
MTBF ¹	LH1000	384 000	h
	LH2000	306 000	
	LH3000	270 000	

¹ Calculated in accordance with MIL-HDBK-217E



Mechanical Data

Dimensions in mm.

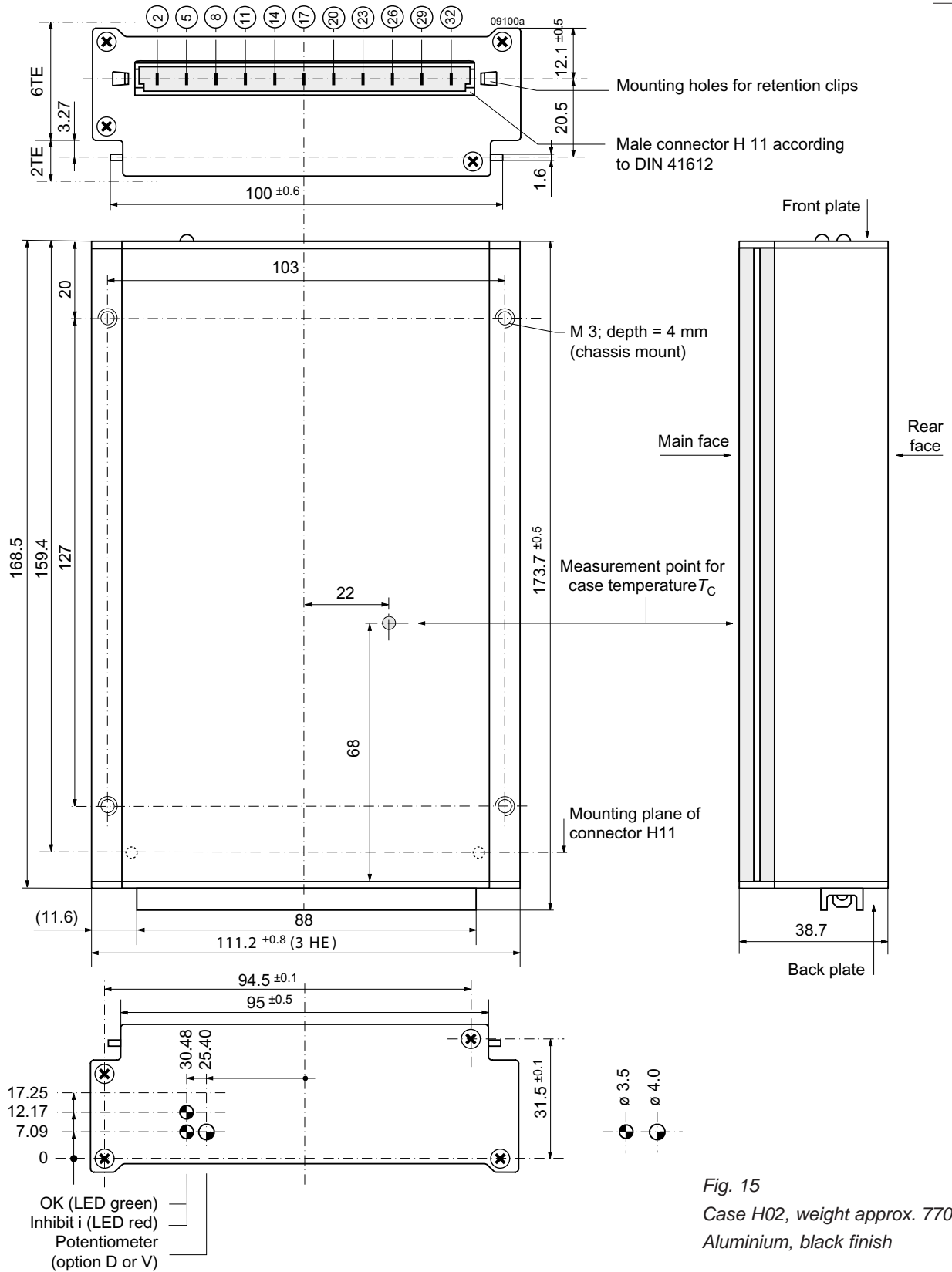

Fig. 15
Case H02, weight approx. 770 g,
Aluminium, black finish

Safety and Installation Instructions

Connector Pin Allocation

Pin no. 26 (protective earth) is leading, ensuring that it makes contact with the female connector first.

Table 12: Pin allocation

Electrical determination	LH1000		LH2000		LH3000	
	Pin	Ident	Pin	Ident	Pin	Ident
Inhibit Safe Data or ACFAIL	2	i	2	i	2	i
	5	D or V ¹	5	D or V ¹	5	D or V ¹
Output voltage (positive)	8	Vo+	8	n.c.	8	Vo3+
Output voltage (negative)	11	Vo-	11	n.c.	11	Vo3-
Voltage adjust	14	R				
Adjust return	17	G				
Output voltage (positive)			14	Vo2+	14	Vo2+
Output voltage (negative)			17	Vo2-	17	Vo2-
Output voltage (positive)	20	Vo+	20	Vo1+	20	Vo1+
Output voltage (negative)	23	Vo-	23	Vo1-	23	Vo1-
Protective earthing PE ²	26	⊕	26	⊕	26	⊕
AC neutral input	29	N _~	29	N _~	29	N _~
AC line input	32	L _~	32	L _~	32	L _~

¹ Not connected, if option neither option D or V is fitted.

² Leading pin

Installation Instructions

The H Series converters are components, intended exclusively for inclusion within other equipment by professional installers. Installation must strictly follow the national safety regulations in compliance with the enclosure, mounting, creepage, clearance, casualty, markings and segregation requirements of the end-use application.

Connection to the system shall be made via the female connector H11. Other installation methods may not meet the safety requirements.

The converters are provided with pin no. 26 (⊕), which is reliably connected with the case. For safety reasons, it is essential to connect this pin with the protective earth of the supply system.

A non-accessible input fuse is connected in the line to pin 32 (L_~). Since this fuse is designed to protect the converter in case of an overcurrent and does not necessarily cover all customer needs, an external fuse suitable for the application and in compliance with the local requirements may be necessary in the wiring to one or both input pins (no. 29 and/or no. 32), particularly if the phase or neutral line cannot be assigned to the corresponding terminals.

Important: If the inhibit function is not in use, pin 2 (i) should be connected with pin 23 (Vo-) to enable the output(s).

Caution: Do not open the converters, or warranty will be invalidated.

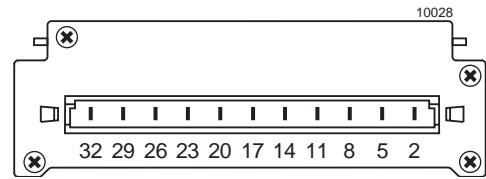

Fig. 16

View of male H11 connector.

Make sure that there is sufficient air flow possible for convection cooling. This should be verified by measuring the case temperature T_C , when the converter is installed and operated in the end-use application. The maximum specified case temperature $T_{C,max}$ shall not be exceeded. See also *Thermal Considerations*.

Cleaning Agents

In order to avoid possible damage, any penetration of liquids (e.g., cleaning fluids) has to be prevented, since the power supplies are not hermetically sealed.

Note: All boards are coated with a protection lacquer.

Protection Degree

Condition: Female connector fitted to the converter.

- IP 40: All models, except those with options D or V with a potentiometer.
- IP 20: All models other models.

Standards and Approvals

The converters correspond to class I equipment and have been approved according to the standards IEC/EN 60950-1 and UL/CSA 60950-1.

The converters have been evaluated for:

- Class I equipment
- Building in
- Basic insulation between input and case and double or reinforced insulation between input and output, based on the input voltage of 250 VAC or 400 VDC
- Functional insulation between output(s) and case
- Functional insulation between the outputs
- Pollution degree 2 environment
- Overvoltage category II
- Altitude up to 2000 m

The converters are subject to manufacturing surveillance in accordance with the above mentioned standards and with ISO 9001:2000.

Isolation

The electric strength test is performed in the factory as routine test in accordance with EN 50116 and IEC/EN 60950, and should not be repeated in the field. Power-One will not honor any warranty claims resulting from electric strength field tests.

Table 12: Isolation

Characteristic		Input to case and output(s)	Output(s) to case	Output to output	Unit
Electric strength test	Factory test >1 s	2.8 ¹	1.4	0.3	kVDC
	AC test voltage equivalent to factory test	2.0	1.0	0.2	kVAC
Insulation resistance at 500 VDC		>300	>300	>100 ²	MΩ

¹ According to EN 50116 and IEC/EN 60950, subassemblies connecting input to output are pre-tested with 5.6 kVDC or 4 kVAC.

² Tested at 300 VDC

Safety of Operator-Accessible Output Circuits

If the output circuit of a DC-DC converter is operator-accessible, it shall be an SELV circuit according to the safety standard IEC/EN 60950.

The table below shows a possible configuration, compliance with which causes the output to be an SELV circuit up to a configured output voltage of 36 V (sum of the nominal voltages connected in series).

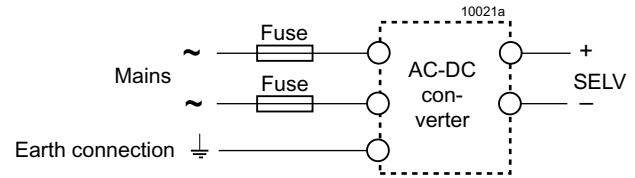

Fig. 17

Schematic safety concept.

Table 13: Safety concept leading to an SELV output circuit

Conditions	AC-DC converter	Installation	Result
Nominal Supply voltage	Grade of insulation between input and output, provided by the AC-DC converter	Measures to achieve the resulting safety status of the output circuit	Safety status of the AC-DC converter output circuit
Mains ≤250 V AC	Double or reinforced	Earthed case ¹ and installation according to the applicable standards	SELV circuit

¹ The earth connection has to be provided by the installer according to the relevant safety standards, e.g. IEC/EN 60950

Description of Options

Table 14: Survey of options

Option	Function of Option	Characteristic
D	Input and/or output undervoltage monitoring circuitry	Safe data signal output (D1 – D8)
V ¹	Input and output undervoltage monitoring circuitry	ACFAIL signal according to VME specifications (V2, V3)

¹ Option V is only available for models with 5.1 V main output; it excludes option D.

D Undervoltage Monitor

The input and/or output undervoltage monitoring circuit operates independently of the built-in input undervoltage lockout circuit. A logic "low" (JFET output) or "high" signal (NPN output) is generated at pin 5, as soon as one of the monitored voltages drops below the preselected threshold

level V_t . The return for this signal is Vo1– (pin 23). The D output recovers, when the monitored voltages exceeds $V_t + V_h$. The threshold level V_t is adjustable by a potentiometer, accessible through a hole in the front cover.

Option D exists in various versions D1 – D8 as shown in table 15.

Table 15: Undervoltage monitor functions

Output type		Monitoring		Minimum adjustment range of threshold level V_t		Typical hysteresis V_h [% of V_t] for $V_{t\ min} - V_{t\ max}$	
JFET	NPN	V_i	V_{o1}	V_{ti}	V_{to}	V_{hi}	V_{ho}
D1	D5	no	yes	–	3.5 V – 48 V ¹	–	2.3 – 1
D2	D6	yes	no	$V_{i\ min} - V_{i\ max}$ ¹	–	3.0 – 0.5	–
D3	D7	yes	yes	$V_{i\ min} - V_{i\ max}$ ¹	0.95 – 0.98 V_{o1} ²	3.0 – 0.5	"0"
D4	D8	no	yes	–	0.95 – 0.98 V_{o1} ²	–	"0"

¹ Threshold level adjustable by potentiometer (not recommended for mobile applications)

² Fixed value between 95% and 98% of V_{o1} (tracking)

JFET output (D1 – D4):

Connector pin D is internally connected via the drain-source path of a JFET (self-conducting type) to the negative potential of output 1. $V_D - 0.4$ V (logic low) corresponds to a monitored voltage level (V_i and/or V_{o1}) $< V_{ti}$. The current I_D through the JFET should not exceed 2.5 mA. The JFET is protected by a 0.5 W Zener diode of 8.2 V against external overvoltages.

V_i, V_{o1} status	D output, V_D
V_i or $V_{o1} < V_{ti}$	low, L, $V_D - 0.4$ V at $I_D = 2.5$ mA
V_i and $V_{o1} > V_{ti} + V_{th}$	high, H, $I_D - 25$ μ A at $V_D = 5.25$ V

NPN output (D5 – D8):

Connector pin D is internally connected via the collector-emitter path of a NPN transistor to the negative potential of output 1. $V_D - 0.4$ V (logic low) corresponds to a monitored voltage level (V_i and/or V_{o1}) $> V_{ti} + V_{th}$. The current I_D through

V_i, V_{o1} status	D output, V_D
V_i or $V_{o1} < V_{ti}$	high, H, $I_D - 25$ μ A at $V_D = 40$ V
V_i and $V_{o1} > V_{ti} + V_{th}$	low, L, $V_D - 0.4$ V at $I_D = 20$ mA

Threshold tolerances and hysteresis:

If V_i is monitored, the internal input voltage after the input filter and rectifier is measured. Consequently, this voltage differs from the voltage at the connector pins by the voltage drop ΔV_{ti} across input filter and rectifier. The threshold level of the D1 and D8 options is adjusted in the factory at nominal output current $I_{o\ nom}$ and $T_A = 25$ °C.

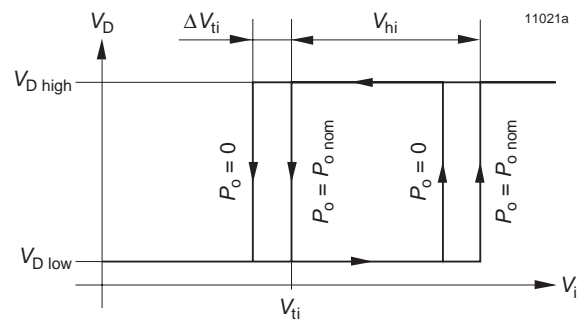

Fig. 20
Definition of V_{ti} , ΔV_{ti} , and V_{hi} (JFET output)

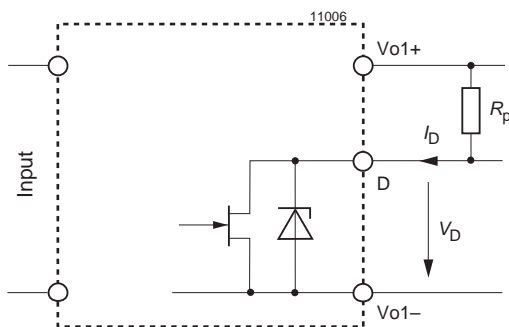

Fig. 18
Options D1 – D4, JFET output

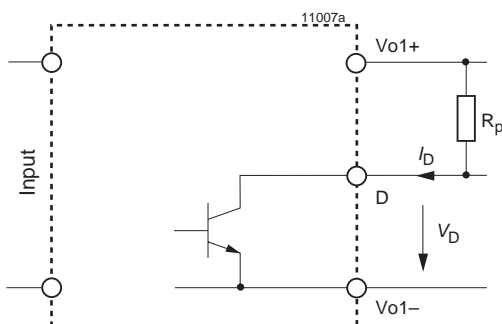
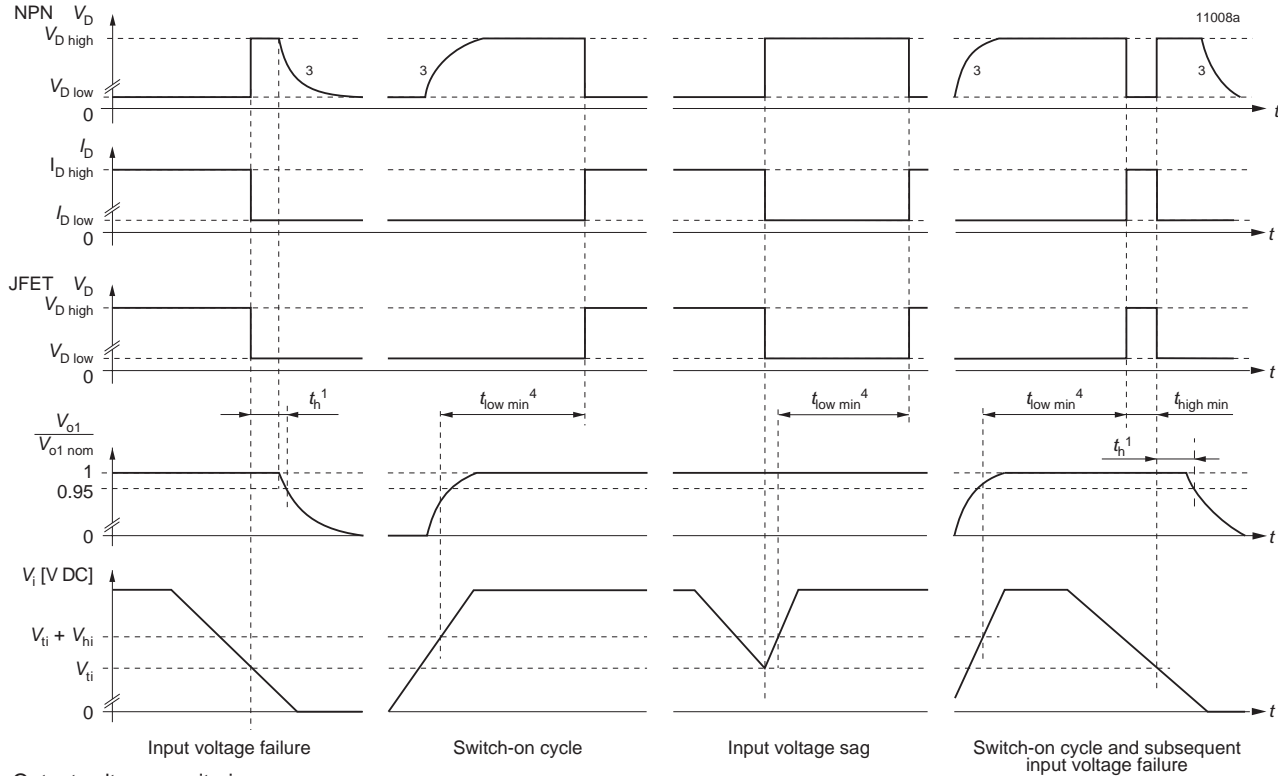
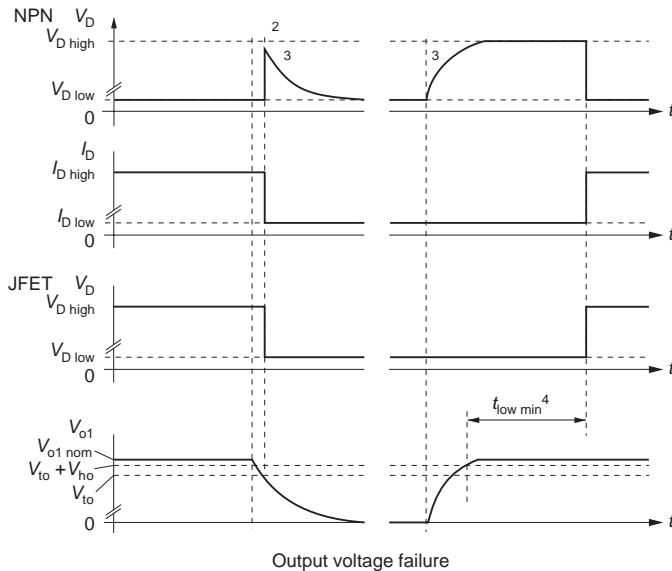

Fig. 19
Options D5 – D8, NPN output

Input voltage monitoring



Output voltage monitoring



- 1 t_h = hold-up time.
- 2 With output voltage monitoring the hold-up time $t_h = 0$
- 3 The D signal remains high, if the D output is connected to an external source.
- 4 $t_{\text{low min}} = 40 - 200$ ms, typically 80 ms

Fig. 21

Relationship between V_i , V_{O1} , V_D , I_D , and $V_{O1}/V_{O1\text{ nom}}$ versus time.

V ACFAIL Signal (VME)

Available for converters with $V_{O1} = 5.1$ V. This option defines an undervoltage monitoring circuit for the input or the input and main output voltage equivalent to option D and generates the ACFAIL signal (V signal), which conforms to the VME standard. The low state level of the ACFAIL signal is specified at a sink current of $I_V = 48$ mA to $V_V - 0.6$ V (open-collector

output). The pull-up resistor feeding the open-collector output should be placed on the VME backplane.

After the ACFAIL signal has gone low, the VME standard requires a hold-up time t_h of at least 4 ms before the 5.1 V output drops to 4.875 V, when the 5.1 V output is fully loaded. This hold-up time t_h is provided by the internal input

capacitance. Consequently, the working input voltage and the threshold level V_{ti} should be adequately above the minimum input voltage $V_{i\min}$ of the converter, so that enough energy is remaining in the input capacitance.

Formula for threshold level for desired value of t_h :

$$V_{ti} = \sqrt{\frac{2 \cdot P_o \cdot (t_h + 0.3 \text{ ms}) \cdot 100}{C_{i\min} \cdot \eta}} + V_{i\min}^2$$

where as:

- $C_{i\min}$ = minimum internal input capacitance [mF], according to the table below
- $C_{i\text{ext}}$ = external input capacitance [mF]
- P_o = output power [W]
- η = efficiency [%]
- t_h = hold-up time [ms]
- $V_{i\min}$ = minimum input voltage [V]
- V_{ti} = threshold level [V]

Note: The threshold level V_{ti} of option V2 and V3 is adjusted in the factory to a value according to table 17.

Table 16: Available internal input capacitance and factory potentiometer setting of V_{ti} with resulting hold-up time

Type	LH	Unit
$C_{i\min}$	0.14	mF
V_{ti}	85	VDC
t_h	5	ms

Option V operates independently of the built-in input under-voltage lockout circuit. A logic "low" signal is generated at pin 5 as soon as one of the monitored voltages drops below the pre-selected threshold level V_t . The return for this signal is Vo1– (pin 23). The V output recovers, when the monitored voltage exceeds $V_t + V_h$. The threshold level V_t is either adjustable by a potentiometer, accessible through a hole in the front cover, or adjusted in the factory to a determined customer-specific value.

Versions V2 and V3 are available as shown below.

Table 17: Undervoltage monitor functions

V output (VME compatible)	Monitoring		Minimum adjustment range of threshold level V_t		Typical hysteresis V_h [% of V_t] for $V_{t\min} - V_{t\max}$	
	V_i	V_{o1}	V_{ti}	V_{to}	V_{hi}	V_{ho}
V2	yes	no	$V_{i\min} - V_{i\max}^1$	-	3.0 – 0.5	-
V3	yes	yes	$V_{i\min} - V_{i\max}^1$	$0.95 - 0.98 V_{o1}^2$	3.0 – 0.5	"0"

¹ Threshold level adjustable by potentiometer (not recommended for mobile applications).

² Fixed value between 95% and 98% of V_{o1} (tracking), output undervoltage monitoring is not a requirement of VME standard.

V output (V2, V3):

Connector pin V is internally connected to the open collector of a NPN transistor. The emitter is connected to the negative potential of output 1. $V_V - 0.6$ V (logic low) corresponds to a monitored voltage level (V_i and/or V_{o1}) $< U_t$. The current I_V through the open collector should not exceed 50 mA. The NPN output is not protected against external overvoltages. V_V should not exceed 60 V.

V_i, V_{o1} status	V output, V_V
V_i or $V_{o1} < V_t$	low, L, $V_V - 0.6$ V at $I_V = 50$ mA
V_i and $V_{o1} > V_t + V_h$	high, H, $I_V - 25$ μ A at $V_V = 5.1$ V

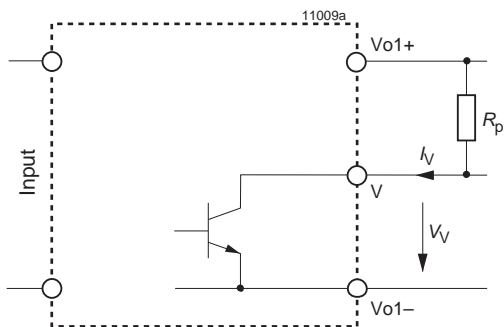

Fig. 22

Output configuration of options V2 and V3

Threshold tolerances and hysteresis:

V_i is monitored after the input filter and rectifier. Consequently, this voltage differs from the voltage at the connector pins by the voltage drop ΔV_{ti} across input filter and rectifier. The threshold level of option V0 is factory-adjusted at $I_{o\text{nom}}$ and $T_A = 25$ °C.

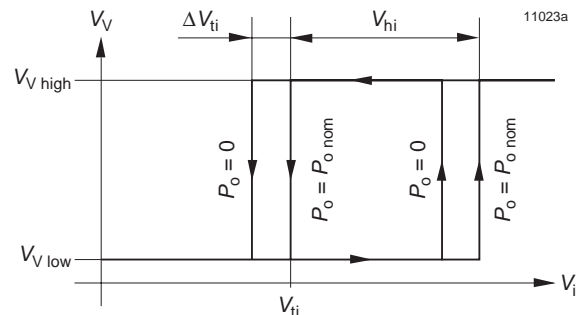

Fig. 23

Definition of V_{ti} , ΔV_{ti} and V_{hi}

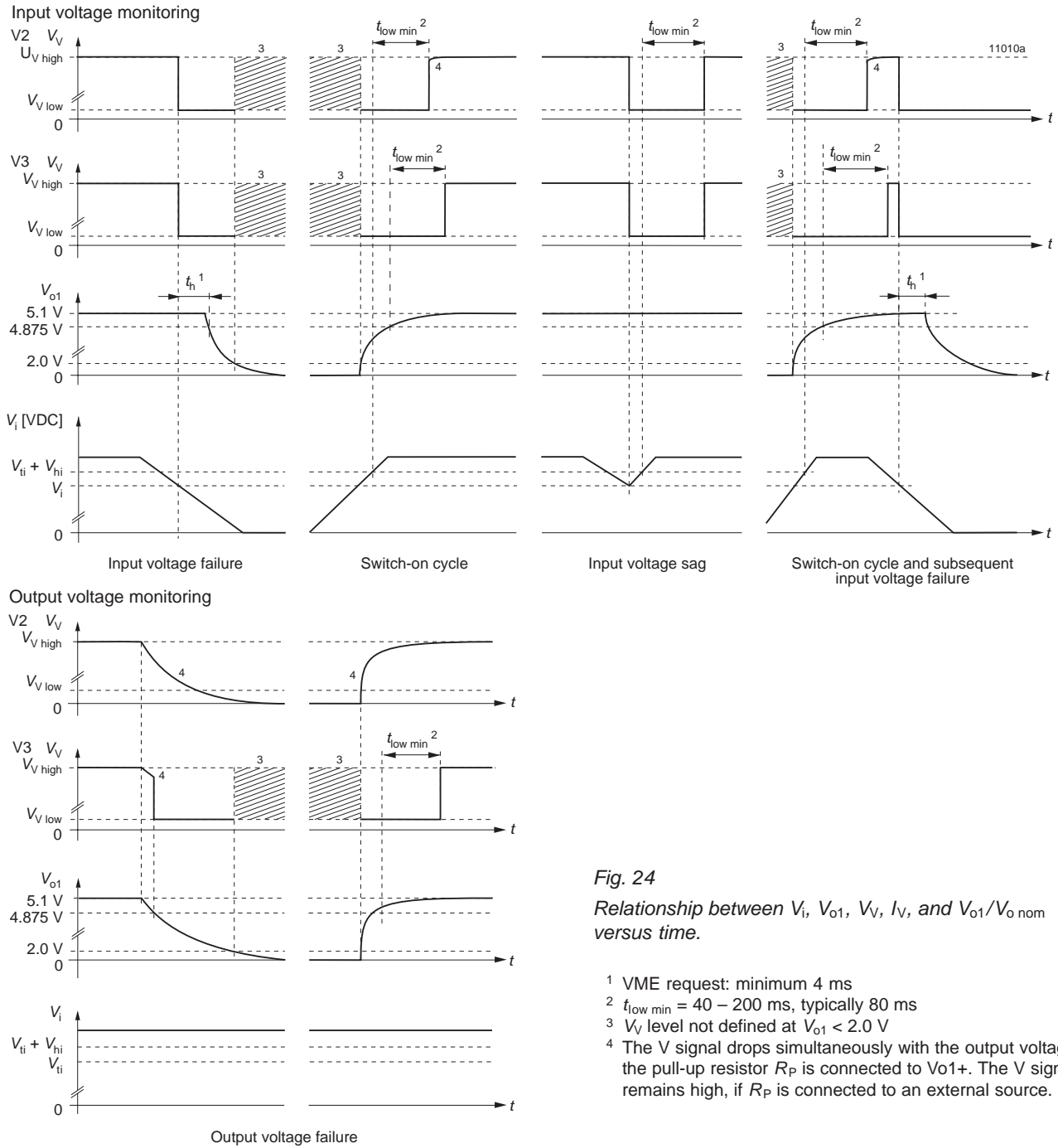

Fig. 24

Relationship between V_i , V_{O1} , V_V , I_V , and $V_{O1}/V_{O\ nom}$ versus time.

- ¹ VME request: minimum 4 ms
- ² $t_{low\ min} = 40 - 200$ ms, typically 80 ms
- ³ V_V level not defined at $V_{O1} < 2.0$ V
- ⁴ The V signal drops simultaneously with the output voltage, if the pull-up resistor R_P is connected to V_{O1+} . The V signal remains high, if R_P is connected to an external source.

Accessories

A great variety of electrical and mechanical accessories are available including:

- Various mating H11 connectors STV-H11-xxx including screw, solder, fast-on, or press-fit terminals
- Connector retention clips RETENTIONCLIP(2X) [HZZ01209]
- Code key system for connector coding CODIERKEIL(5X)
- Various front panels for 19" rack mounting, width 8 TE, height 3U and 6U, Schroff or Intermas system.
- Flexible H11 PCB for mounting the converter onto a PCB
- Universal mounting bracket UMB-LHMQ [HZZ00610] for chassis mounting or DIN-rail mounting in upright position.
- DIN-rail mounting brackets DMB-MHQ (horizontal position)
- Mounting plate M (black finish) MOUNTINGPLATEM for mounting the converter to a chassis or a wall, where only frontal access is given
- Battery sensor [S-KSMH...] for using the converter as battery charger. Different cell characteristics can be selected.

For additional accessory product information, see the accessory data sheets listed with each product series or individual model listing at www.power-one.com.

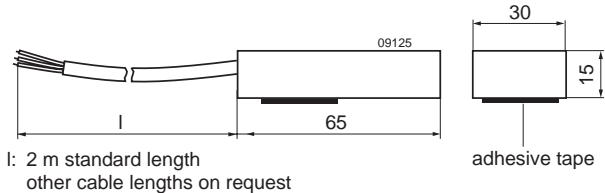
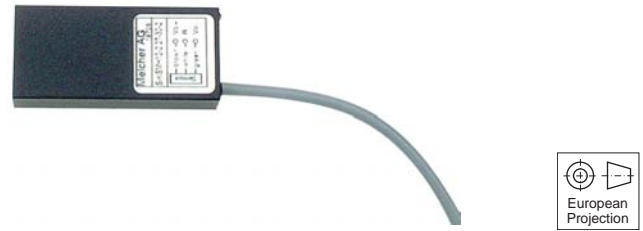

Battery temperature sensor

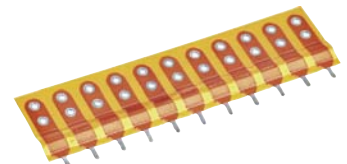

Flexible H11 PCB

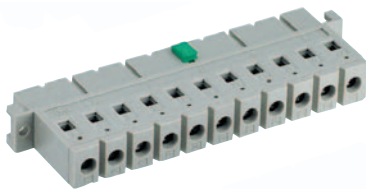

H11 female connector with screw terminals and code key system



Connector retention clip



DIN-rail mounting brackets DMB-MHQ



Mounting plate M (for wall-mounting), connector with fast-on terminals (STV-H11-F/CO), secured with connector retention clips



Universal mounting bracket UMB-LHMQ for DIN-rail mounting.



Different front panels

X-ON Electronics

Largest Supplier of Electrical and Electronic Components

Click to view similar products for [Switching Power Supplies](#) category:

Click to view products by [Bel Fuse](#) manufacturer:

Other Similar products are found below :

[70841011](#) [73-551-0005](#) [AAD600S-4-OP](#) [R22095](#) [HWS50A-5/RA](#) [KD0204](#) [9021](#) [S-15F-12](#) [LDIN100150](#) [LPM000-BBAR-01](#) [LPX17S-C](#)
[EVS57-10R6/R](#) [FDC40-24S12](#) [FRV7000G](#) [22929](#) [CQM1IA121](#) [40370121900](#) [VI-PU22-EXX](#) [40370121910](#) [LDIN5075](#) [432703037161](#)
[WRB01X-U](#) [LPX140-C](#) [08-30466-1040G](#) [09-160CFG](#) [70841004](#) [70841025](#) [VPX3000-CBL-DC](#) [LPM000-BBAR-05](#) [LPM000-BBAR-08](#)
[LPM124-OUTA1-48](#) [LPM000-BBAR-07](#) [LPM109-OUTA1-10](#) [LPM616-CHAS](#) [08-30466-1055G](#) [08-30466-2175G](#) [DMB-EWG](#) [TVQF-](#)
[1219-18S](#) [6504-226-2101](#) [CQM1IPS01](#) [XPFM201A+](#) [MAP80-4000G](#) [LFP300F-24-TY](#) [SMP21-L20-DC24V-5A](#) [VI-MUL-ES](#) [08-30466-](#)
[0065G](#) [CME240P-24](#) [VI-RU031-EWWX](#) [08-30466-0028G](#) [S82Y-TS01](#)