

MULTILAYER CERAMIC CHIP INDUCTORS

AIMC-0402

RoHS
Compliant



1.0 x 0.5 x 0.5mm

FEATURES:

- High self-resonant frequency
- Multilayer monolithic construction yields high reliability
- Excellent solderability & heat resistance for reflow soldering

APPLICATIONS:

- Bluetooth
- Mobile phones such as GSM, CDMA, PDC
- High frequency telecommunication circuits
- Other high frequency circuit general use

STANDARD SPECIFICATIONS:

PARAMETERS

ABRACON P/N:	AIMC-0402-xxx Series
Operating temperature:	-55°C to + 125°C

Part No.	L(nH)	Tolerance	L,Q Test Freq. (MHz)	Q (MIN)	SRF(MHz) (min)	DCR(Ω) (max)	Ir(mA) (max)
AIMC-0402-1N0	1.0	C, S	100	9	10000	0.08	400
AIMC-0402-1N2	1.2	C, S	100	9	10000	0.08	400
AIMC-0402-1N5	1.5	C, S	100	9	6000	0.10	400
AIMC-0402-1N8	1.8	C, S	100	9	6000	0.12	400
AIMC-0402-2N2	2.2	C, S	100	9	6000	0.12	400
AIMC-0402-2N7	2.7	C, S	100	9	6000	0.13	400
AIMC-0402-3N3	3.3	C, S	100	9	6000	0.15	400
AIMC-0402-3N9	3.9	C, S	100	9	4500	0.21	400
AIMC-0402-4N7	4.7	C, S	100	9	4500	0.21	300
AIMC-0402-5N6	5.6	C, S	100	9	4000	0.23	300
AIMC-0402-6N8	6.8	C, S	100	9	4000	0.25	300
AIMC-0402-8N2	8.2	C, S	100	9	3600	0.35	300
AIMC-0402-10N	10	J	100	9	3200	0.42	300
AIMC-0402-12N	12	J	100	9	2800	0.50	300
AIMC-0402-15N	15	J	100	9	2500	0.60	300
AIMC-0402-18N	18	J	100	9	2200	0.80	300
AIMC-0402-22N	22	J	100	9	1900	0.85	300
AIMC-0402-27N	27	J	100	9	1600	1.00	300
AIMC-0402-33N	33	J	100	9	1300	1.00	200
AIMC-0402-39N	39	J	100	9	1200	1.30	200
AIMC-0402-47N	47	J	100	9	1000	1.50	200
AIMC-0402-56N	56	J	100	9	800	1.80	200
AIMC-0402-68N	68	J	100	9	800	1.95	180
AIMC-0402-82N	82	J	100	9	600	2.10	150
AIMC-0402-R10	100	J	100	9	600	2.50	150
AIMC-0402-R12	120	J	100	9	600	2.80	150

Test Conditions and equipments

L, Q: HP4291 Impedance Analyzer, 100MHz, 50mV

DCR: HP4263A LCR meter

SRF: HP4291 Impedance analyzer, HP8753 Network analyzer

Ir: DC Power Supplier, Current Meter,

Thermometer. $\Delta L/L$ (initial) $\geq -5\%$ or $\Delta T \leq 20^\circ\text{C}$

Unless otherwise specified

Temperature : Ordinary Temperature (5 to 35°C)

Humidity : Ordinary Humidity (25 to 85% RH)

Atmospheric Pressure : 86 to 106 kPa

OPTIONS AND PART IDENTIFICATION:

(Left blank if standard)

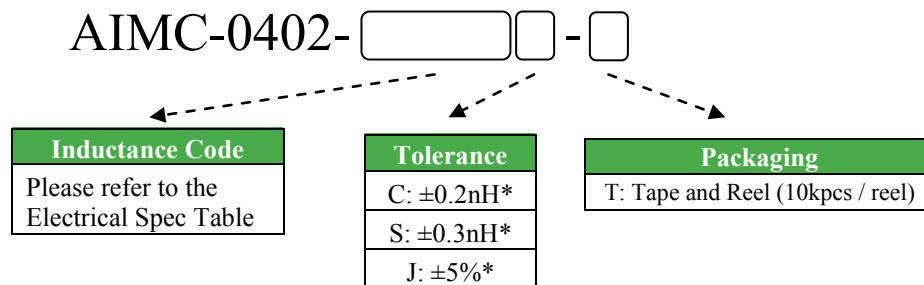

* C, S for L = 1.0~8.2nH

J for L = 10~120nH

ABRACON IS
ISO 9001:2008
CERTIFIED

ABRACON[®]
The Power of Linking Together

2 Faraday, Suite# B | Irvine | CA 92618 Revised: 02.26.16

Ph. 949.546.8000 | Fax. 949.546.8001

Visit www.abracon.com for Terms and Conditions of Sale

MULTILAYER CERAMIC CHIP INDUCTORS

AIMC-0402

RoHS
Compliant



1.0 x 0.5 x 0.5mm

OUTLINE DRAWING:

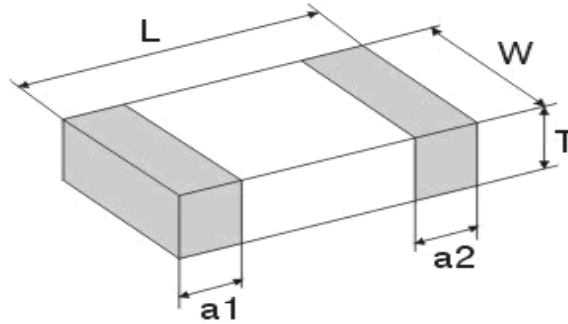

Dimensions: mm [inch]

Series	L	W	T	a1,a2
AIMC-0402	1.00±0.15	0.50±0.15	0.50±0.15	0.25±0.10
	[0.04±0.006]	[0.02±0.006]	[0.02±0.006]	[0.01±0.004]

REFLOW PROFILE:

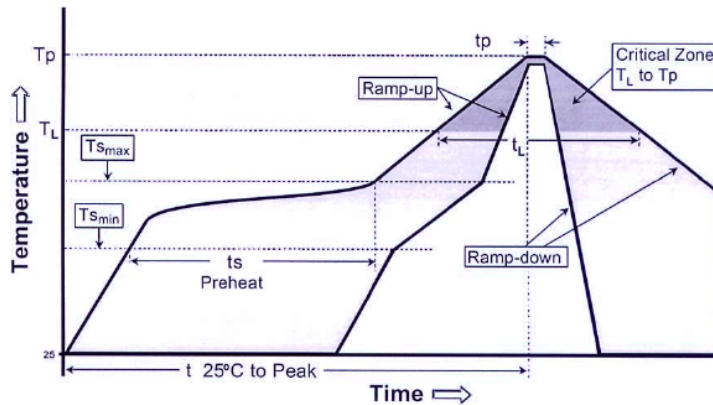

Profile Feature	Lead-Free Assembly
Average Ramp-Up Rate (T _{smax} to T _p)	3°C /second max.
Preheat - Temperature Min (T _{sm}) - Temperature Max (T _{smx}) - Time (t _{sm} to t _{smx}) min to t _{smx})	150 °C 200 °C 60-180 seconds
Time maintained above: - Temperature (T _l) - Time (t _l)	217 °C 60-150 seconds
Peak/Classification Temperature (T _p) Peak/Classification Time (T _p)	260 °C 3-4 seconds
Time within 5 °C of actual Peak Temperature (t _p)	20-40 seconds
Ramp-Down Rate	6°C/second max.
Time 25 °C to Peak Temperature	8 minutes max.

ABRACON IS
ISO 9001:2008
CERTIFIED



2 Faraday, Suite# B | Irvine | CA 92618 Revised: 02.26.16
Ph. 949.546.8000 | Fax. 949.546.8001
Visit www.abracon.com for Terms and Conditions of Sale

MULTILAYER CERAMIC CHIP INDUCTORS

AIMC-0402

RoHS
Compliant



1.0 x 0.5 x 0.5mm

TAPE & REEL:

T = Tape and reel 10,000pcs/reel

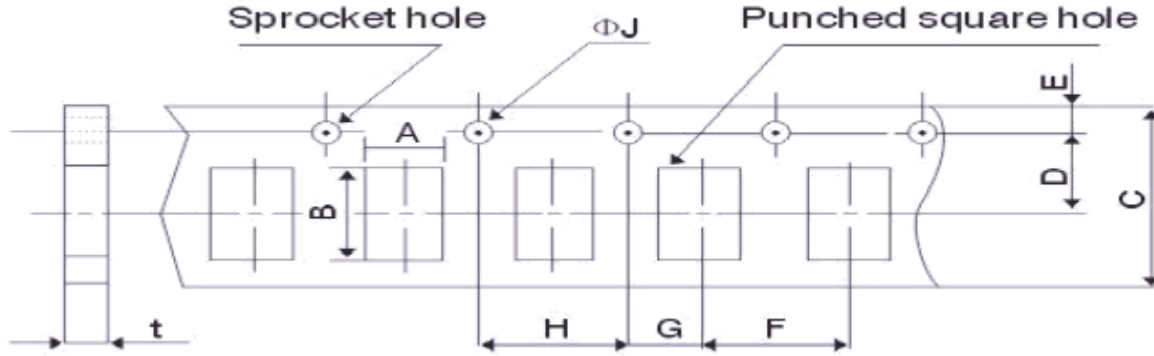

Codes	A	B	C	D	E	F	G	H	ΦJ	t(max)
AIMC-0402	0.65±0.10	1.15±0.10	8.0±0.3	3.5±0.05	1.75±0.1	2.0±0.05	2.0±0.05	4.0±0.1	1.5+0.1/-0	0.8±0.05

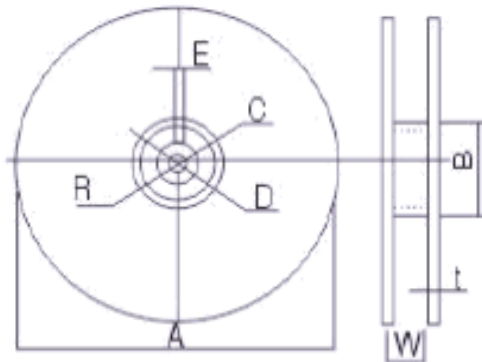

A	178±2
B	60±2
C	13.0±0.5
D	21.0±0.8
E	2.0±0.5
W	10.0±1.15
t	1.2±0.2
R	1.0±0.25

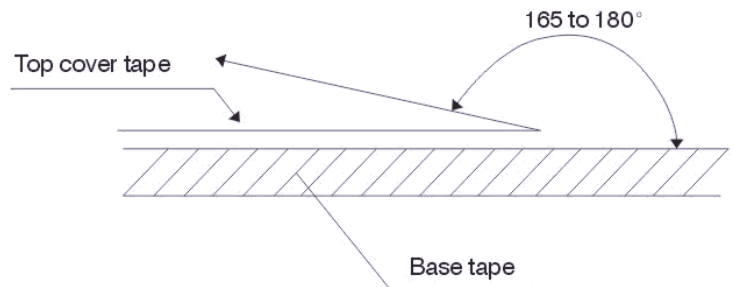

- Test condition:
- 1) peel angle: 165°~180° vs. carrier tape.
 - 2) peel speed: 300 mm/min±10%.

Dimension: mm

ATTENTION: Abracon Corporation's products are COTS – Commercial-Off-The-Shelf products; suitable for Commercial, Industrial and, where designated, Automotive Applications. Abracon's products are not specifically designed for Military, Aviation, Aerospace, Life-dependant Medical applications or any application requiring high reliability where component failure could result in loss of life and/or property. For applications requiring high reliability and/or presenting an extreme operating environment, written consent and authorization from Abracon Corporation is required. Please contact Abracon Corporation for more information.

ABRACON IS
ISO 9001:2008
CERTIFIED

ABRACON[®]
LLC
The Power of Linking Together

2 Faraday, Suite# B | Irvine | CA 92618 Revised: 02.26.16
Ph. 949.546.8000 | Fax. 949.546.8001
Visit www.abracon.com for Terms and Conditions of Sale

X-ON Electronics

Largest Supplier of Electrical and Electronic Components

Click to view similar products for [Multilayer Ceramic Capacitors MLCC - SMD/SMT](#) category:

Click to view products by [ABRACON](#) manufacturer:

Other Similar products are found below :

[M39014/01-1467](#) [M39014/02-1218V](#) [M39014/02-1225V](#) [M39014/02-1262V](#) [M39014/02-1301](#) [M39014/22-0631](#) [1210J5000102JCT](#)
[1210J2K00102KXT](#) [1210J5000103KXT](#) [1210J5000223KXT](#) [D55342E07B379BR-TR](#) [D55342E07B523DR-T/R](#) [1812J1K00103KXT](#)
[1812J1K00473KXT](#) [1812J2K00680JCT](#) [1812J4K00102MXT](#) [1812J5000102JCT](#) [1812J5000103JCT](#) [1812J5000682JCT](#) [NIN-FB391JTRF](#)
[NIN-FC2R7JTRF](#) [NPIS27H102MTRF](#) [C1206C101J1GAC](#) [C1608C0G1E472JT000N](#) [C2012C0G2A472J](#) [2220J2K00101JCT](#)
[KHC201E225M76N0T00](#) [LRC-LRF1206LF-01R025FTR1K](#) [1812J1K00222JCT](#) [1812J2K00102KXT](#) [1812J2K00222KXT](#)
[1812J2K00472KXT](#) [2-1622820-7-CUT-TAPE](#) [2220J3K00102KXT](#) [2225J2500824KXT](#) [CCR07CG103KM](#) [CGA2B2C0G1H010C](#)
[CGA2B2C0G1H040C](#) [CGA2B2C0G1H050C](#) [CGA2B2C0G1H060D](#) [CGA2B2C0G1H070D](#) [CGA2B2C0G1H151J](#) [CGA2B2C0G1H1R5C](#)
[CGA2B2C0G1H2R2C](#) [CGA2B2C0G1H3R3C](#) [CGA2B2C0G1H680J](#) [CGA2B2C0G1H6R8D](#) [CGA2B2X8R1H221K](#) [CGA2B2X8R1H472K](#)
[CGA3E1X7R1C474K](#)