

max. 540 m³/h

DC diagonal fans

Series DV 6200 172 Ø x 51 mm

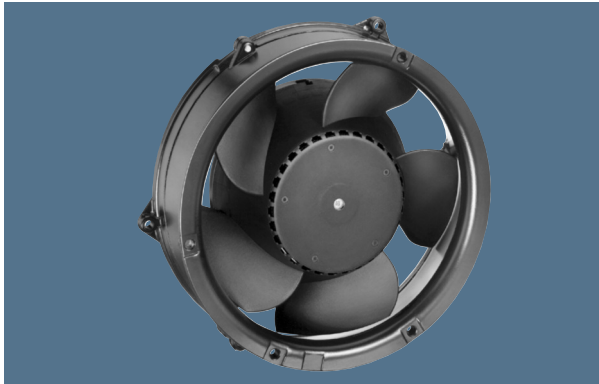

Highlights:

- Diagonal compact fan with low noise and high pressure saddle.
- Very rigid compression curve for high air flow at high back pressure.

General characteristics:

- Material: aluminium housing, fibreglass-reinforced PA impeller; housing with grounding lug for screw M4 x 8 (Torx). 48 V version incl. screws.
- Fully integrated electronic commutation.
- Protected against reverse polarity and locking.
- Connection via single strands AWG 22, TR 64. Bared and tin-plated.
- Air exhaust over struts. Direction of rotation counter-clockwise, seen on rotor.
- Mass: 820 g.

| Nominal data | Air flow | | Nominal voltage | Voltage range | Sound pressure level | Sound power level | Sinter sleeve bearings Ball bearings | Power input | Nominal speed | Temperature range | Service life L ₁₀ (40 °C) ebm-papst Standard | Service life L ₁₀ (T _{max}) ebm-papst Standard | Life expectancy L ₁₀ ^Δ (40 °C) see P. 15 | Curve | Specials |
|--------------|-------------------|-------|-----------------|---------------|----------------------|-------------------|---|-------------|---------------|-------------------|--|--|---|-------|----------|
| | m ³ /h | CFM | | | | | | | | | | | | | |
| DV 6224 | 540 | 317,8 | 24 | 16...28 | 63 | 7,1 | ■ | 40,0 | 4 300 | -20...+75 | 90 000 / 40 000 | 180 000 | 1 | /2/12 | |
| DV 6248 | 540 | 317,8 | 48 | 28...60 | 63 | 7,1 | ■ | 40,0 | 4 300 | -20...+75 | 90 000 / 40 000 | 180 000 | 1 | | |

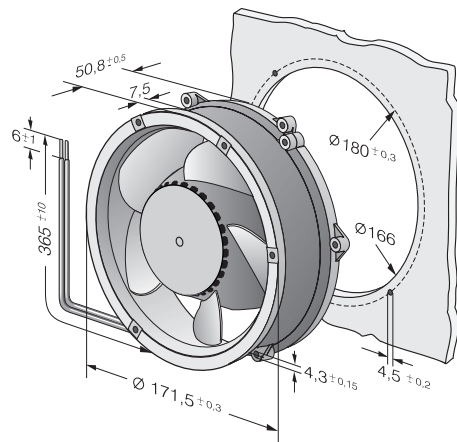
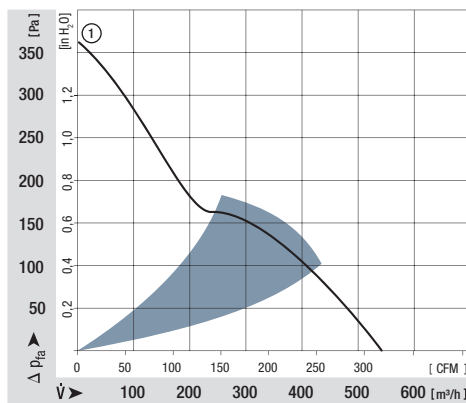

Speed signal /2

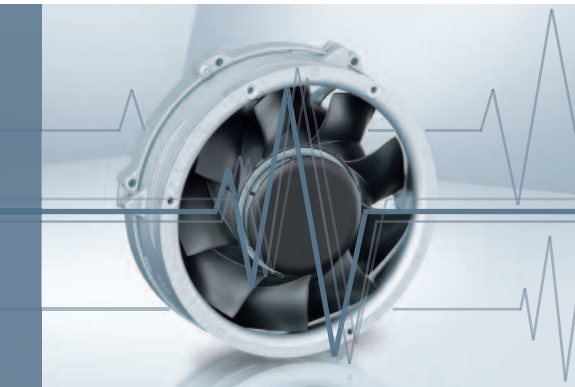

- Speed-proportional, square-wave signal for external monitoring of the fan motor speed
- 2, 3, or 6 pulses per revolution
- Open-collector signal output
- Extremely wide operating voltage range
- Easy adaptation to user interface
- Connection via separate cable
- The sensor signal also serves as a major comparison variable for setting and maintaining the setpoint speed for interactive or controlled cooling with one or more interconnected fans.

Electrical hookup

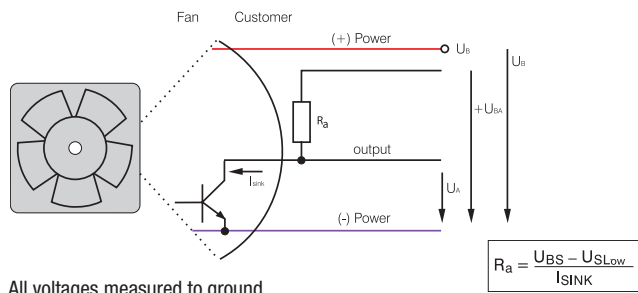

All voltages measured to ground.
External load resistor $R_a / U_S / U_{BS}$ required.

$$R_a = \frac{U_{BS} - U_{S\text{Low}}}{I_{\text{SINK}}}$$

Signal output voltage

Standard signal for all models (exceptions see below)

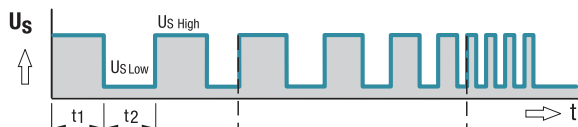

Signal frequency $[F] = 3 \times n / 60\text{Hz}$

For multi options control input and 4100 NH7 and NH8

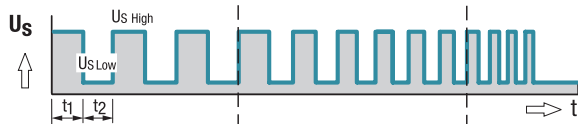

Signal frequency $[F] = 3 \times n / 60\text{Hz}$

All TD Fans e.g. 6300 TD

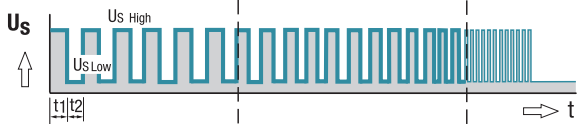

Signal frequency $[F] = 6 \times n / 60\text{Hz}$

Fan speed

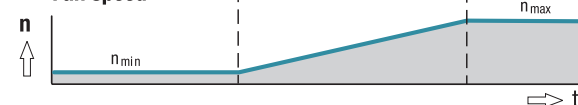

| Signal data | Speed signal $U_{S\text{Low}}$ | Condition: I_{sink} | Speed signal $U_{S\text{High}}$ | Condition: I_{source} | Tach operating voltage $U_{BS\text{max}}$ | Admissible sink current $I_{\text{sink max}}$ | Pulses per revolution | Fan description Basic type |
|----------------------|--------------------------------|------------------------------|---------------------------------|--------------------------------|---|---|-----------------------|----------------------------|
| Type | VDC | mA | VDC | mA | VDC | mA | Page | |
| 250 | ≤ 0.4 | 2 | ≤ 30 | 0 | 30 | 2 | 2 | 31 |
| 400 F | ≤ 0.4 | 1 | ≤ 30 | 0 | 30 | 2 | 2 | 32 |
| 400 | ≤ 0.4 | 1 | ≤ 30 | 0 | 30 | 2 | 2 | 33 |
| 420 J | ≤ 0.4 | 2 | ≤ 15 | 0 | 15 | 4 | 2 | 34 |
| 500 F | ≤ 0.4 | 1 | ≤ 30 | 0 | 30 | 2 | 2 | 35 |
| 600 F | ≤ 0.4 | 1 | ≤ 30 | 0 | 30 | 2 | 2 | 36 |
| 620 | ≤ 0.4 | 2 | ≤ 30 | 0 | 30 | 4 | 2 | 37 |
| 630 U | ≤ 0.4 | 2 | ≤ 30 | 0 | 30 | 4 | 2 | 38 |
| 600 N | ≤ 0.4 | 2 | ≤ 28 | 0 | 28 | 4 | 2 | 39 |
| 600 J | ≤ 0.4 | 2 | ≤ 30 | 0 | 30 | 4 | 2 | 41 |
| 700 F | ≤ 0.4 | 2 | ≤ 30 | 0 | 30 | 4 | 2 | 42 |
| 8450 | ≤ 0.4 | 2 | ≤ 28 | 0 | 28 | 4 | 2 | 43 |
| 8400 N | ≤ 0.4 | 2 | ≤ 28 | 0 | 28 | 4 | 2 | 44 |
| 8400 N VARIOFAN | ≤ 0.4 | 2 | ≤ 30 | 0 | 30 | 4 | 2 | 45 |
| 8300 | ≤ 0.4 | 2 | ≤ 30 | 0 | 30 | 4 | 2 | 46 |
| 8200 J | ≤ 0.4 | 2 | ≤ 30 | 0 | 30 | 4 | 2 | 47 |
| 3400 N | ≤ 0.4 | 2 | ≤ 28 | 0 | 28 | 4 | 2 | 48 |
| 3400 N VARIOFAN | ≤ 0.4 | 2 | ≤ 30 | 0 | 30 | 4 | 2 | 49 |
| 3300 N | ≤ 0.4 | 2 | ≤ 30 | 0 | 30 | 4 | 2 | 50 |
| 3212 J / 3214 J | ≤ 0.4 | 2 | ≤ 30 | 0 | 30 | 4 | 2 | 51 |
| 3218 J | ≤ 0.4 | 2 | ≤ 60 | 0 | 60 | 4 | 2 | 51 |
| 3250 J | ≤ 0.4 | 2 | ≤ 60 | 0 | 60 | 4 | 3 | 52 |
| 4412 F / 4414 F | ≤ 0.4 | 2 | ≤ 30 | 0 | 30 | 4 | 2 | 53 |
| 4418 F | ≤ 0.4 | 2 | ≤ 60 | 0 | 60 | 4 | 2 | 53 |
| 4400 FN | ≤ 0.4 | 2 | ≤ 30 | 0 | 30 | 4 | 2 | 55 |
| 4312 / 4314 | ≤ 0.4 | 2 | ≤ 30 | 0 | 30 | 4 | 2 | 56 |
| 4318 | ≤ 0.4 | 2 | ≤ 60 | 0 | 60 | 4 | 2 | 56 |
| 4312 / 4314 VARIOFAN | ≤ 0.4 | 2 | ≤ 30 | 0 | 30 | 4 | 2 | 57 |
| 4318 VARIOFAN | ≤ 0.4 | 2 | ≤ 60 | 0 | 60 | 4 | 2 | 57 |
| 4400 | ≤ 0.4 | 2 | ≤ 30 | 0 | 30 | 4 | 2 | 58/59 |
| 4100 N | ≤ 0.4 | 2 | ≤ 30 | 0 | 30 | 4 | 2 | 60 |
| 4100 NHH...NH6 | ≤ 0.4 | 2 | ≤ 60 | 0 | 60 | 10 | 2 | 61 |
| 4100 NH7...NH8 | ≤ 0.4 | 2 | ≤ 60 | 0 | 60 | 20 | 3 | 62 |
| DV 4100 | ≤ 0.4 | 2 | ≤ 30 | 0 | 30 | 4 | 2 | 63 |
| 5200 N | ≤ 0.4 | 2 | ≤ 30 | 0 | 30 | 4 | 2 | 64 |
| DV 5200 | ≤ 0.4 | 2 | ≤ 30 | 0 | 30 | 4 | 2 | 65 |

Subject to change

Available on request:

- Electrically isolated speed signal circuit
- Varying voltage potentials for power and logic circuit

| Signal data | Speed signal $U_{S, Low}$ | Condition: I_{Sink} | Speed signal $U_{S, High}$ | Condition: I_{Source} | Tach operating voltage $U_{GS, max.}$ | Admissible sink current $I_{Sink, max.}$ | Pulses per revolution | Fan description Basic type |
|-----------------|------------------------------|-----------------------|-------------------------------|-------------------------|--|---|-----------------------|-------------------------------|
| Type | VDC | mA | VDC | mA | VDC | mA | | Page |
| 5112 N | ≤ 0.4 | 2 | ≤ 15 | 0 | 5 | 20 | 2 | 66 |
| 5114 N / 5118 N | ≤ 0.4 | 2 | ≤ 60 | 0 | 60 | 20 | 2 | 66 |
| 5300 | ≤ 0.4 | 2 | ≤ 60 | 0 | 60 | 4 | 2 | 67 |
| 5300 TD | ≤ 0.4 | 2 | ≤ 60 | 0 | 60 | 20 | 6 | 68 |
| 7112 N / 7118 N | ≤ 0.4 | 2 | ≤ 60 | 0 | 60 | 20 | 2 | 69 |
| 7114 N | ≤ 0.4 | 2 | ≤ 30 | 0 | 30 | 20 | 2 | 69 |
| 7200 N | ≤ 0.4 | 2 | ≤ 15 | 0 | 15 | 20 | 2 | 70 |
| 6400 | ≤ 0.4 | 2 | ≤ 60 | 0 | 60 | 20 | 2 | 71 |
| 6300 TD | ≤ 0.4 | 2 | ≤ 60 | 0 | 60 | 20 | 6 | 75 |
| 6300 N | ≤ 0.4 | 2 | ≤ 60 | 0 | 60 | 20 | 6 | 76 |
| 6300 NTD | ≤ 0.4 | 2 | ≤ 60 | 0 | 60 | 20 | 6 | 77 |
| 6300 | ≤ 0.4 | 2 | ≤ 60 | 0 | 60 | 20 | 2 | 78 |
| DV 6300 TD | ≤ 0.4 | 2 | ≤ 60 | 0 | 60 | 20 | 6 | 80 |
| 2200 FTD | ≤ 0.4 | 2 | ≤ 60 | 0 | 60 | 20 | 6 | 81 |
| RL 48 | ≤ 0.4 | 2 | ≤ 30 | 0 | 30 | 4 | 2 | 97 |
| RL 65 | ≤ 0.4 | 2 | ≤ 30 | 0 | 30 | 4 | 2 | 98 |
| RL 90 N | ≤ 0.4 | 2 | ≤ 30 | 0 | 30 | 4 | 2 | 99 |
| RLF 100 | ≤ 0.4 | 2 | ≤ 30 | 0 | 30 | 4 | 2 | 100 |
| RG 90 N | ≤ 0.4 | 2 | ≤ 30 | 0 | 30 | 4 | 2 | 101 |
| RG 125 N | ≤ 0.4 | 2 | ≤ 30 | 0 | 30 | 4 | 2 | 102 |
| RG 140 N | ≤ 0.4 | 3 | ≤ 60 | 0 | 60 | 4 | 2 | 103 |
| RG 160 N | ≤ 0.4 | 2 | ≤ 30 | 0 | 30 | 20 | 2 | 104 |
| RG 160 NTD | ≤ 0.4 | 2 | ≤ 60 | 0 | 60 | 20 | 6 | 105 |
| RG 190 TD | ≤ 0.4 | 2 | ≤ 60 | 0 | 60 | 20 | 6 | 106 |
| RG 220 TD | ≤ 0.4 | 2 | ≤ 60 | 0 | 60 | 20 | 6 | 107 |
| RG 225 TD | ≤ 0.4 | 2 | ≤ 60 | 0 | 60 | 20 | 6 | 108 |
| RET 97 TD | ≤ 0.4 | 2 | ≤ 60 | 0 | 60 | 20 | 6 | 109 |
| REF 100 | ≤ 0.4 | 2 | ≤ 30 | 0 | 30 | 4 | 2 | 110 |
| RER 120 TD | ≤ 0.4 | 2 | ≤ 60 | 0 | 60 | 20 | 6 | 112 |
| RER 133 TD | ≤ 0.4 | 2 | ≤ 60 | 0 | 60 | 20 | 6 | 117 |
| RER 160 NTD | ≤ 0.4 | 2 | ≤ 60 | 0 | 60 | 20 | 6 | 119 |
| REF 175 TD | ≤ 0.4 | 2 | ≤ 60 | 0 | 60 | 20 | 6 | 120 |
| RER 175 TD | ≤ 0.4 | 2 | ≤ 60 | 0 | 60 | 20 | 6 | 121 |
| RER 190 TD | ≤ 0.4 | 2 | ≤ 60 | 0 | 60 | 20 | 6 | 122 |
| RER 220 TD | ≤ 0.4 | 2 | ≤ 60 | 0 | 60 | 20 | 6 | 128 |
| RER 225 TD | ≤ 0.4 | 2 | ≤ 60 | 0 | 60 | 20 | 6 | 129 |

Subject to change

Note:

Fans that come with these fan specials could have variations with respect to the temperature range, voltage range, and power consumption compared to standard fans without specials.

X-ON Electronics

Largest Supplier of Electrical and Electronic Components

Click to view similar products for [AC Fans](#) category:

Click to view products by [ebm papst](#) manufacturer:

Other Similar products are found below :

[M2E068-DF13-79](#) [F1238H24B-FHR](#) [8850A](#) [G9225S05B2-FSR](#) [A2D200-AA04-41](#) [A2E165-AA17-01](#) [R2D140-AB02-14](#) [R4D310-AS18-01](#)
[R4D400-AD22-06](#) [R4E180-AS11-09](#) [AD0912HB-A7BGL](#) [1500-FAN-01](#) [25.001.1856.0](#) [25.320.1153.1](#) [25.320.1353.1](#) [25.320.4753.1](#)
[25.320.5453.1](#) [25.330.1353.1](#) [25.330.4853.1](#) [25.330.5153.1](#) [25.330.5353.1](#) [25.340.1053.1](#) [25.350.5253.0](#) [25.600.4053.0](#) [272DL-2LP11-000](#)
[S2E250-AL06-70](#) [A2D210-AB10-05](#) [A2D240-AA02-02](#) [A2D250-AE22-06](#) [A2E170-AF23-01](#) [F1238S24BT-FSR](#) [25.000.1856.0](#)
[25.000.2056.0](#) [25.010.1856.0](#) [25.220.3953.1](#) [25.332.2453.1](#) [25.340.0453.1](#) [25.345.5353.0](#) [25.352.1853.0](#) [281DS-2LP11-000B](#) [281DY-](#)
[1LP14-000B](#) [298DM-2LP11-000](#) [298DS-2LP11-000A](#) [R2S150-AD08-09](#) [344DY-1LP11-000](#) [39.703.0253.0](#) [USTF1203224VHW](#)
[3915100996-SA3](#) [3G2C7MC224](#) [W2D200-HH04-07](#)