

PART NO.	ENGINEERING NO.	FINISHED LENGTH
1300100107	115031K13M010	1.0M+55.6mm-0 [3'3"+2.19-0]
1300100108	115031K13M020	2.0M+88.9mm-0 [6'7"+3.50-0]

CHART
C

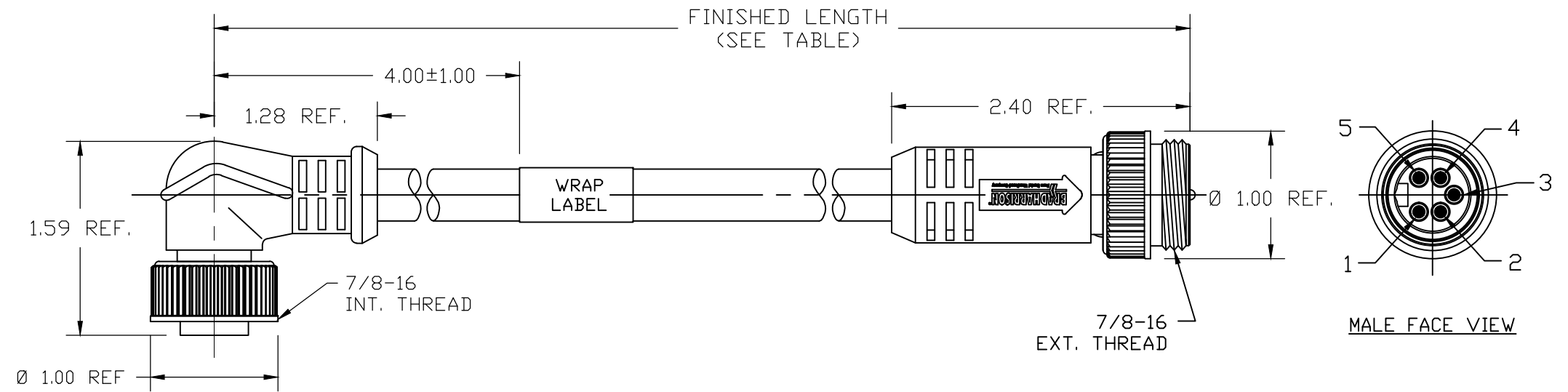

115031K13M010

cable type
16/5C AWG
TPE YELLOW

cable length
M005= 0.5 METER
M010= 1 METER
M100= 10 METER

SPECIFICATIONS:

COUPLING NUT MATERIAL: ZINC DIECAST WITH BLACK ELECTROPHORETIC COATING
 CONTACT MATERIAL: GOLD/NICKEL OVER COPPER ALLOY
 INSERT MATERIAL: YELLOW TPE
 OVERMOLD MATERIAL: YELLOW TPE

CABLE: #16/5 YELLOW TPE
 TC-ER & FT4 RATED

ASSEMBLY RATING: 600V, 10A PER UL 2238
 400V, 10A PER IEC 60664

ENVIRONMENTAL: -40°C TO 90°C ©
 IP67 WHEN MATED

AGENCY APPROVALS: UL LISTED PER FILE: E152210

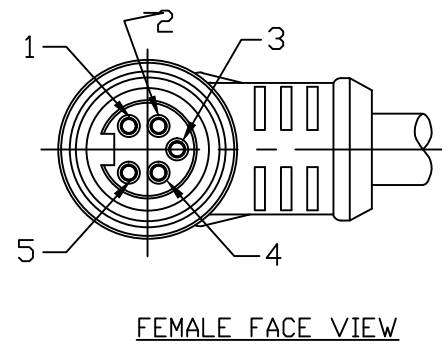

1	WHITE	1
2	RED	2
3	GREEN/YELLOW	3
4	ORANGE	4
5	BLACK	5

CABLE LENGTH TOLERANCES	
>.3M [1FT]:	+19mm-0 [+.75in-0]
.3 - .9M [1 - 3FT]:	+44.5mm-0 [+1.75in-0]
.9 - 1.8M [3 - 6FT]:	+55.6mm-0 [+2.19in-0]
1.8 - 3.7M [6 - 12FT]:	+88.9mm-0 [+3.50in-0]
3.7 - 7.3M [12 - 24FT]:	+165.1mm-0 [+6.50in-0]
7.3-14.6M [24 - 48FT]:	+317.5mm-0 [+12.50in-0]
14.6 - 30.5M [48-100FT]:	+622.3mm-0 [+24.50in-0]
OVER 30M [100FT]	+2% OF FINISHED LENGTH

MECHANICAL CHARACTERISTICS:

TORSIONAL FLEX TEST	20 MILLION CYCLES PER MIL-C-13777G
BEND FLEX TEST	20 MILLION CYCLES PER MIL-C-13777G
WELD SLAG RESISTANCE	WOODHEAD STANDARD S-300

ADD TABLE FOR PARTS & REV TEMP EC NO: IPG2018-0001 DRWN: AAKHTAR 2017/07/06 CHKD: MZIELIN 2017/07/06 APPR: BWOODMAN 2013/04/05	DESCRIPTION REV	QUALITY SYMBOLS $\nabla=0$ $\nabla C=0$	GENERAL TOLERANCES (UNLESS SPECIFIED)		DIMENSION STYLE INCH ONLY		SCALE ---	DESIGN UNITS INCH	THIRD ANGLE PROJECTION			
			mm	INCH	DRAWN BY VOU	DATE 2012/02/17	TITLE MINI-CHANGE CORDSET 5P MALE/FEMALE ST/90 #16/5 TPE CABLE					
			4 PLACES	±---	±---	CHECKED BY TWOLEDGE	DATE 2013/03/04	MOLEX INCORPORATED				
			3 PLACES	±---	±---	APPROVED BY JFMURPHY	DATE 2013/04/05	DOCUMENT NO. SD-130010-021				
	2 PLACES	±---	±.01	MATERIAL NO.		SEE CHART		SHEET NO. 1 OF 1				
	1 PLACE	±---	±---	DRAFT WHERE APPLICABLE MUST REMAIN WITHIN DIMENSIONS		SIZE B		THIS DRAWING CONTAINS INFORMATION THAT IS PROPRIETARY TO MOLEX INCORPORATED AND SHOULD NOT BE USED WITHOUT WRITTEN PERMISSION				

F

E

D

C

B

A

F

E

D

C

B

A

X-ON Electronics

Largest Supplier of Electrical and Electronic Components

Click to view similar products for [Sensor Cables / Actuator Cables](#) category:

Click to view products by [Molex](#) manufacturer:

Other Similar products are found below :

[1300070444](#) [43-10984](#) [M83513/19-F01CP](#) [704000D02F120](#) [MDM15SH001K](#) [MDM25PH003BF222](#) [802027107404-1](#) [885030A09M010](#)
[885030A09M020](#) [1200650174](#) [1200651332](#) [1200651713](#) [1200660171](#) [1200660208](#) [1200660343](#) [1200660804](#) [1200660845](#) [1200660926](#)
[1200660977](#) [1200661173](#) [1200661354](#) [120066-1712](#) [1200720053](#) [1200720099](#) [1200720153](#) [1200720172](#) [1200720217](#) [1200720226](#)
[1200720251](#) [1200720285](#) [1200720296](#) [1200720404](#) [1200730148](#) [1200730378](#) [1200800231](#) [1200860112](#) [1200860121](#) [1200860125](#)
[1200860337](#) [1200860365](#) [1200860420](#) [1200870046](#) [1200870123](#) [1200870248](#) [1200980102](#) [1200660181](#) [1200660183](#) [1200660827](#)
[1200660849](#) [1200661170](#)