

THIS DRAWING IS UNPUBLISHED. RELEASED FOR PUBLICATION APR , 2011.
 © COPYRIGHT 2011 By Tyco Electronics Japan G.K. ALL RIGHTS RESERVED.

LOC	DIST	REVISIONS		
J	-	P	LTR	DESCRIPTION
		F2	REVISED	DATE DWN APVD
				20MAR'15 J.W C.W

VACUUM PICK UP AREA

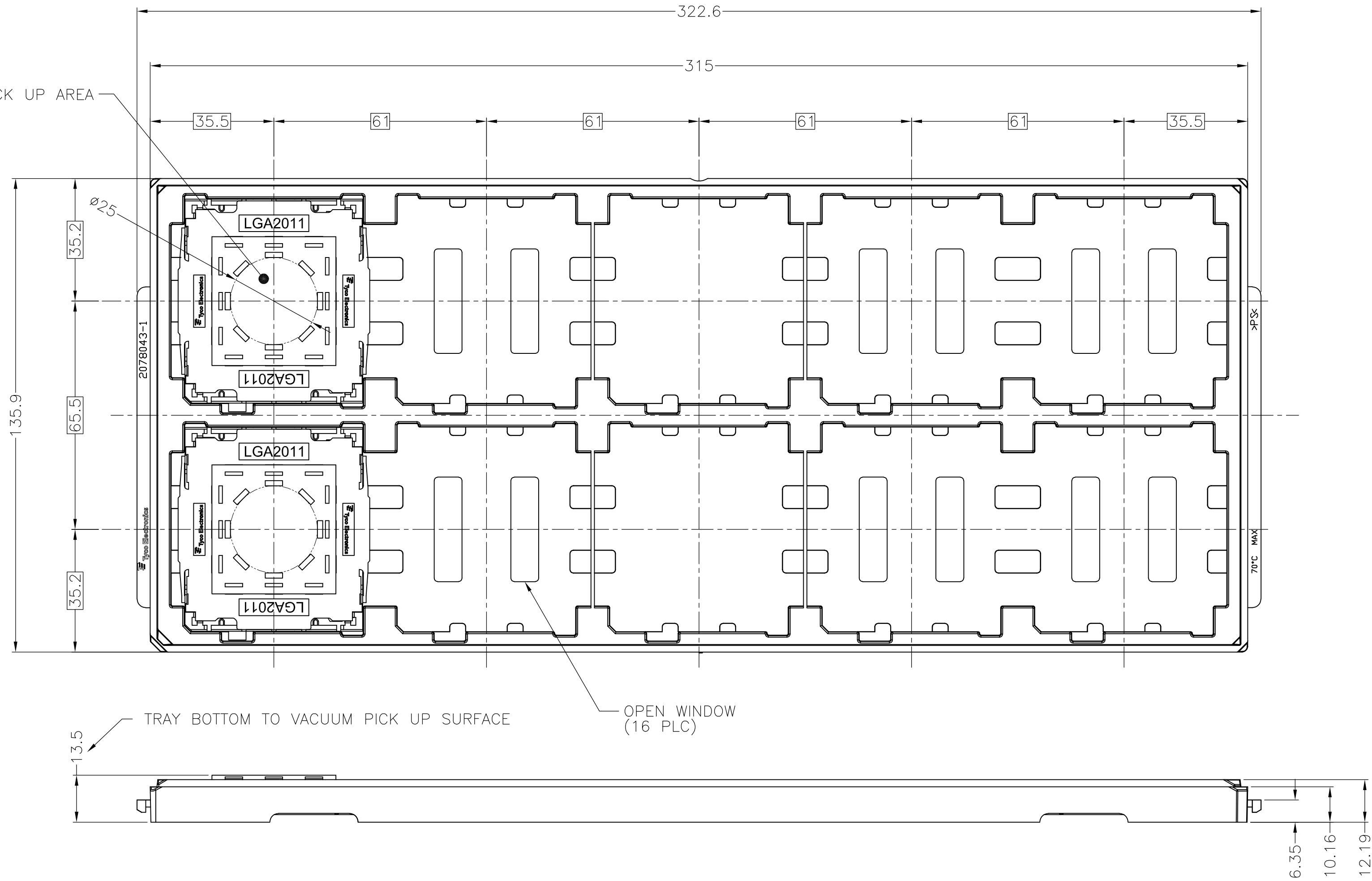

1. MATERIAL

- ① HOUSING : HIGH TEMP, THERMO-PLASTIC, UL94V-0, BLACK
- ② CONTACT : COPPER ALLOY
FINISH : Au PL. AT CONTACT AREA ON OVERALL OVER Ni UNDER PL. 0.00127 MIN.
- ③ SOLDER BALL : Sn/Ag/Cu
- ④ CAP : HIGH TEMP. THERMO-PLASTIC, UL94V-0, BLACK
- △ INDICATED DATE CODE ON THE HSG
- △ Au PL. ON Pd-Ni ALLOY PL. AT CONTACT AREA ON OVERALL OVER Ni UNDER PL. 0.00127 MIN.
- 4. PACKAGE TYPE: HARD TRAY, BLUE

2-1554653-1	LGA2011-0	Au PL ON Pd-Ni PL △
1-1554653-1	LGA2011-0	0.76 um MIN Au PL
1554653-1	LGA2011-0	0.38 um MIN Au PL
PART NUMBER	SOCKET NAME	DESCRIPTION

THIS DRAWING IS A CONTROLLED DOCUMENT.		DWN	J.MIZUSHIMA	05JUL2010		TE Connectivity		
DIMENSIONS: 単位: 寸 mm		CHK	H.TAGUCHI	05JUL2010		NAME 名称	SOCKET ASSY	
TOLERANCES UNLESS OTHERWISE SPECIFIED: 一般公差		APVD	T.NAKASHIMA	05JUL2010			LGA2011-0	
0-PLC ± ±0.5 1-PLC ± ±0.5 2-PLC ± ±0.5 3-PLC ± ±0.5 4-PLC ± ±0.5 ANGLES ± ±		PRODUCT SPEC	108-78750			SIZE	A2	CAGE CODE
MATERIAL 材料		APPLICATION SPEC	114-5474		DRAWING NO 番号	C=1554653		RESTRICTED TO
FINISH 仕上		WEIGHT	19.1g		SCALE 尺度	NTS		SHEET 1 of 6
		CUSTOMER DRAWING			REV	F2		

THIS DRAWING IS UNPUBLISHED. RELEASED FOR PUBLICATION APR , 2011.
 © COPYRIGHT 2011 By Tyco Electronics Japan G.K. ALL RIGHTS RESERVED.

LOC	DIST	REVISIONS					
J	-	P	LTR	DESCRIPTION	DATE	DWN	APVD
		-	-	SEE SHEET 1	-	-	-

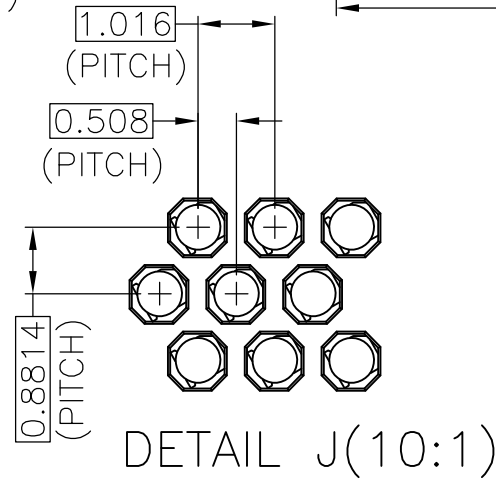
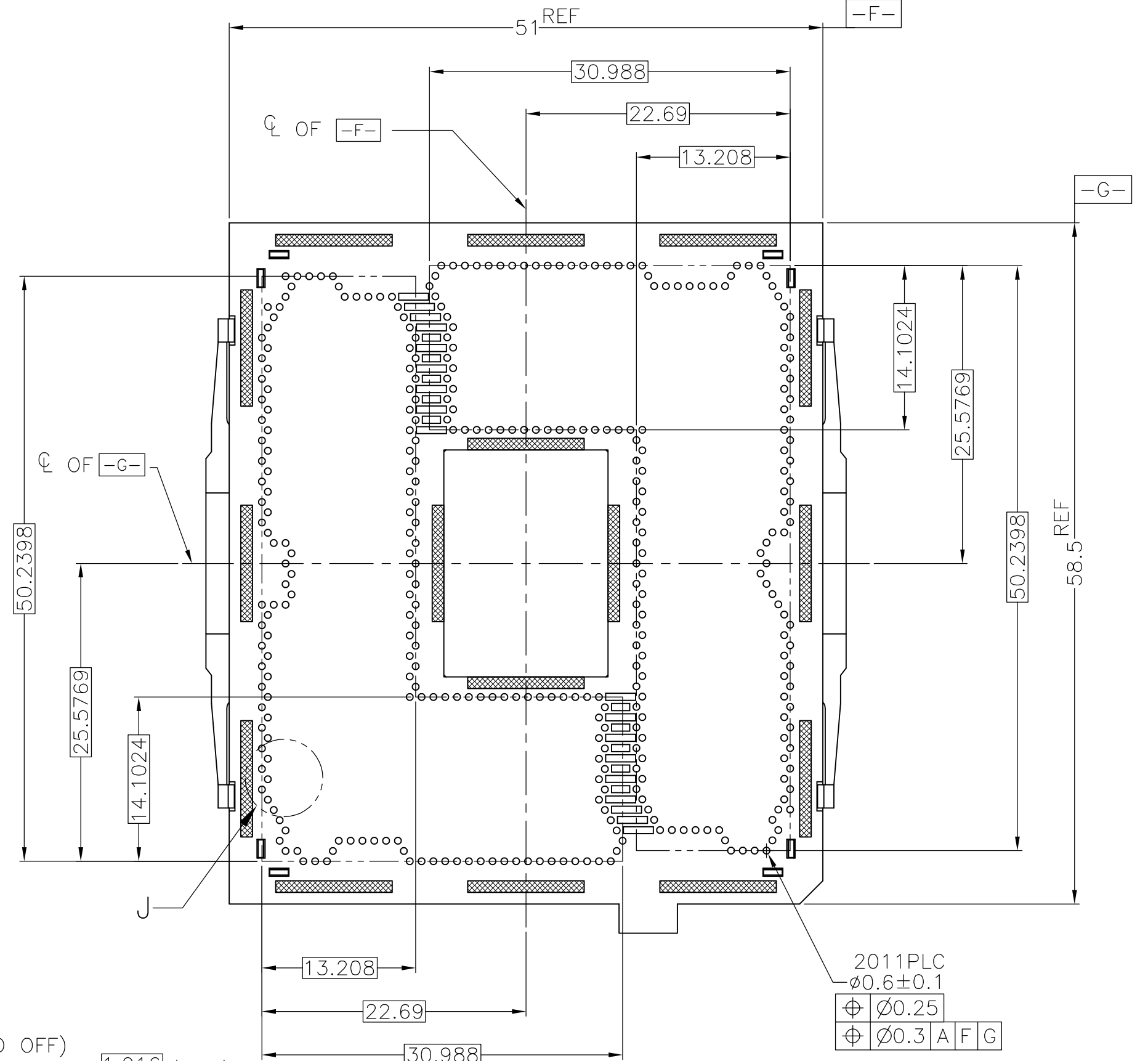
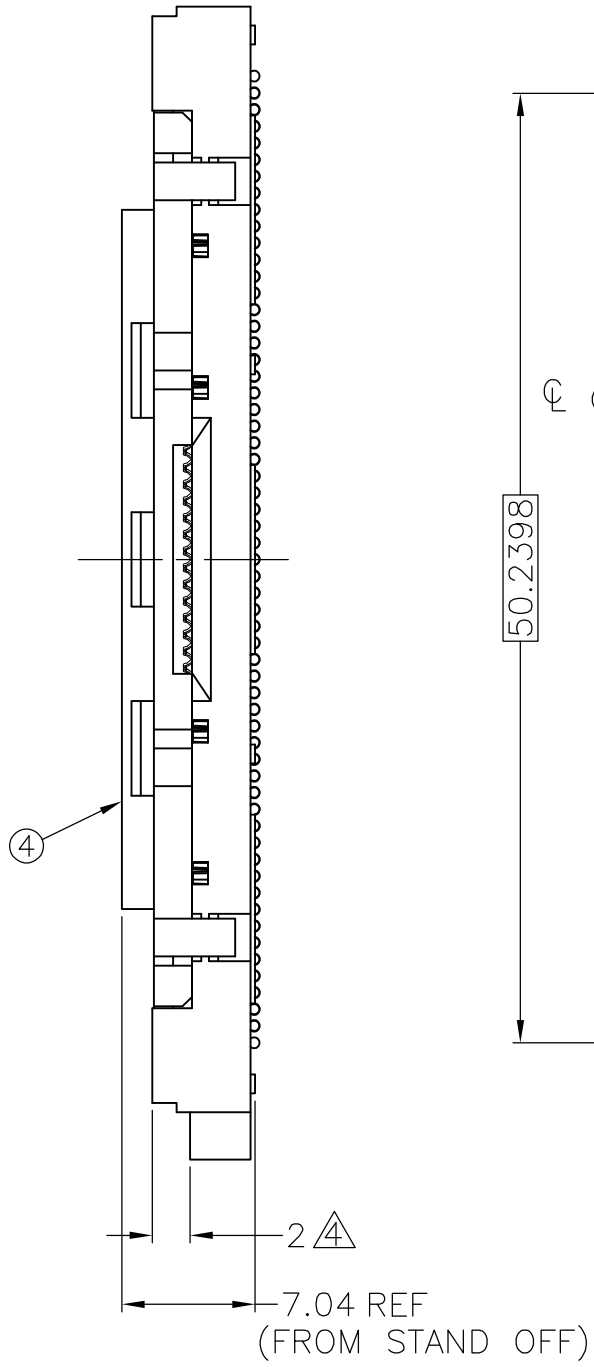
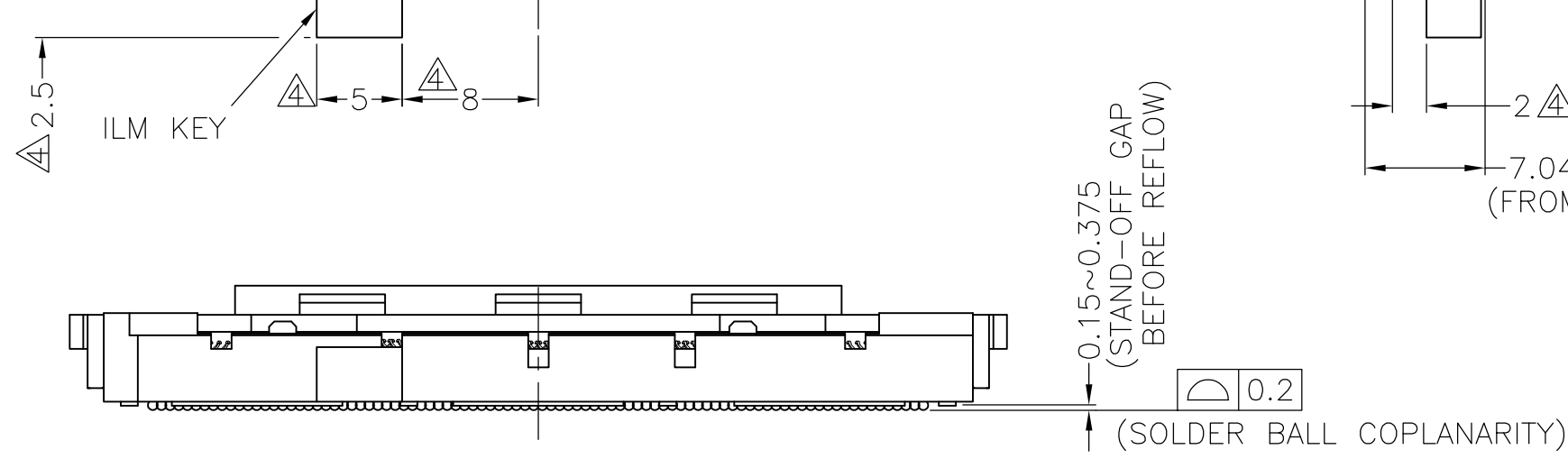
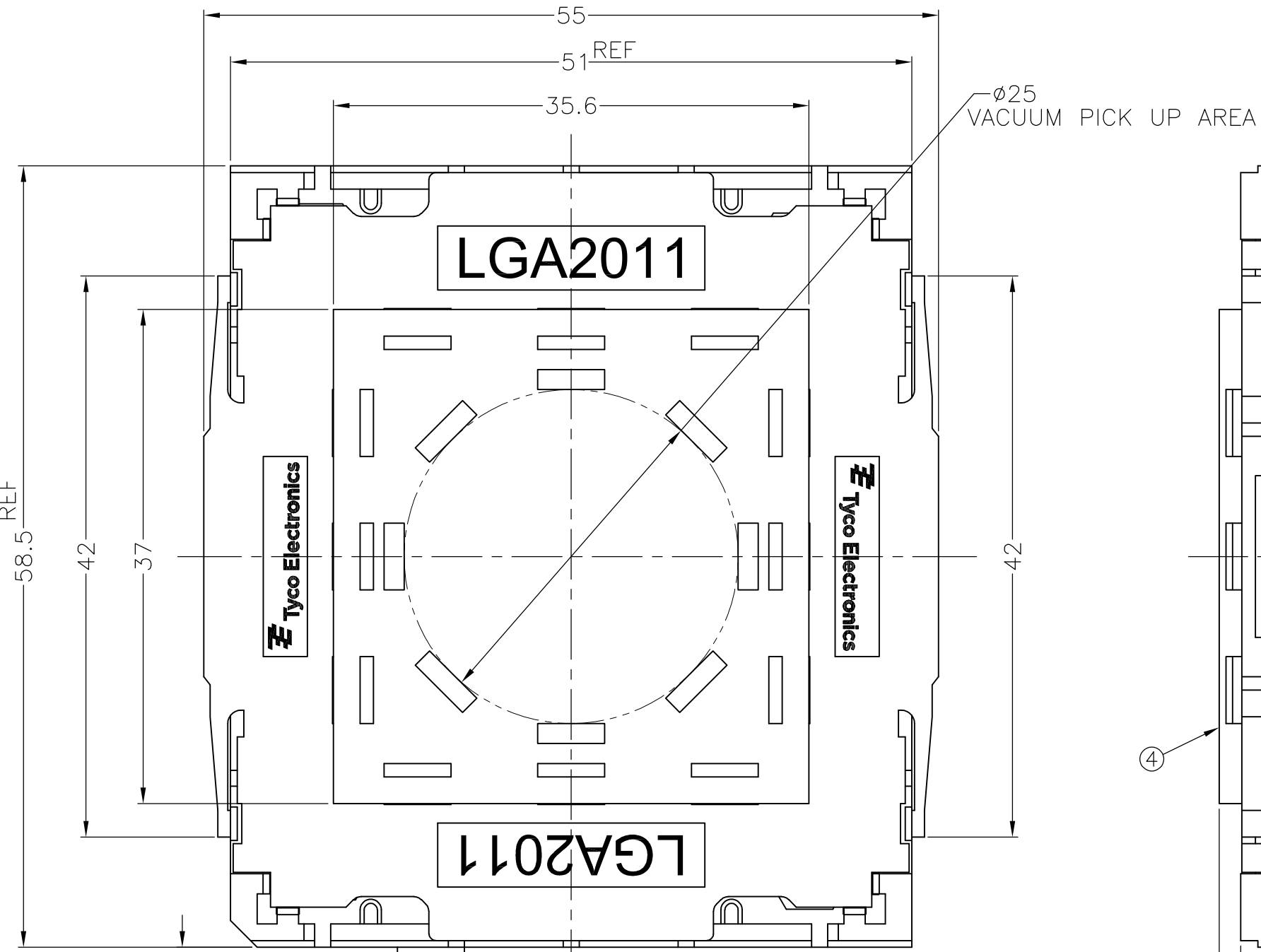
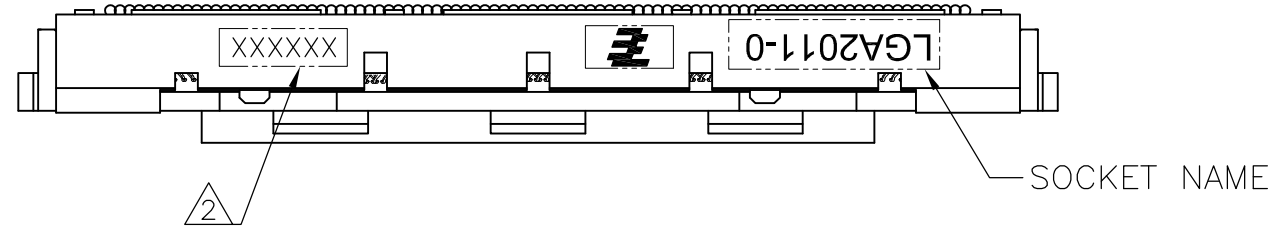

2011PLC
 $\varnothing 0.6 \pm 0.1$
 $\varnothing 0.25$
 $\varnothing 0.3$ A F G

THIS DRAWING IS A CONTROLLED DOCUMENT.		DWN	-	TE Connectivity SOCKET ASSY LGA2011-0	
DIMENSIONS: 单位: 毫米 mm		CHK	-		
TOLERANCES UNLESS OTHERWISE SPECIFIED: 一般公差		APVD	-	NAME	名称
\varnothing PLC ± 0.3 \pm PLC ± 0.3 \pm PLC ± 0.3 \pm PLC ± 0.3 ANGLES \pm		PRODUCT SPEC	-	SIZE	A2
MATERIAL 材料		APPLICATION SPEC	-	CAGE CODE	00779
FINISH 仕上		WEIGHT	-	DRAWING NO 番号	C=1554653
		CUSTOMER DRAWING	-	RESTRICTED TO	-
		SCALE	NTS	SHEET	2 of 6
		REV	F2		

THIS DRAWING IS UNPUBLISHED. RELEASED FOR PUBLICATION APR, 2011.
 © COPYRIGHT 2011 By Tyco Electronics Japan G.K. ALL RIGHTS RESERVED.

LOC		DIST		REVISIONS			DATE	DWN	APVD
P	LTR	DESCRIPTION							
-	-	SEE SHEET 1			-	-	-	-	

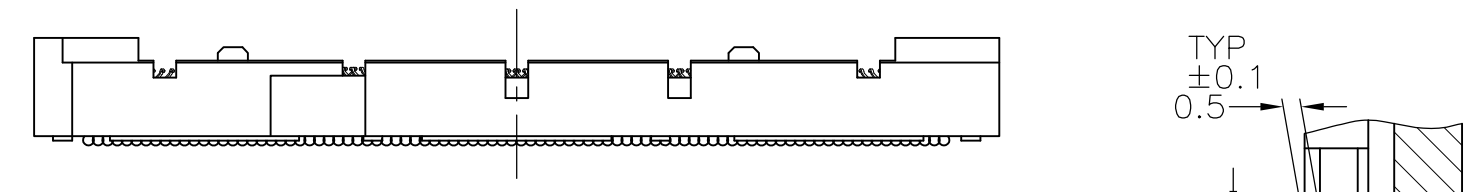
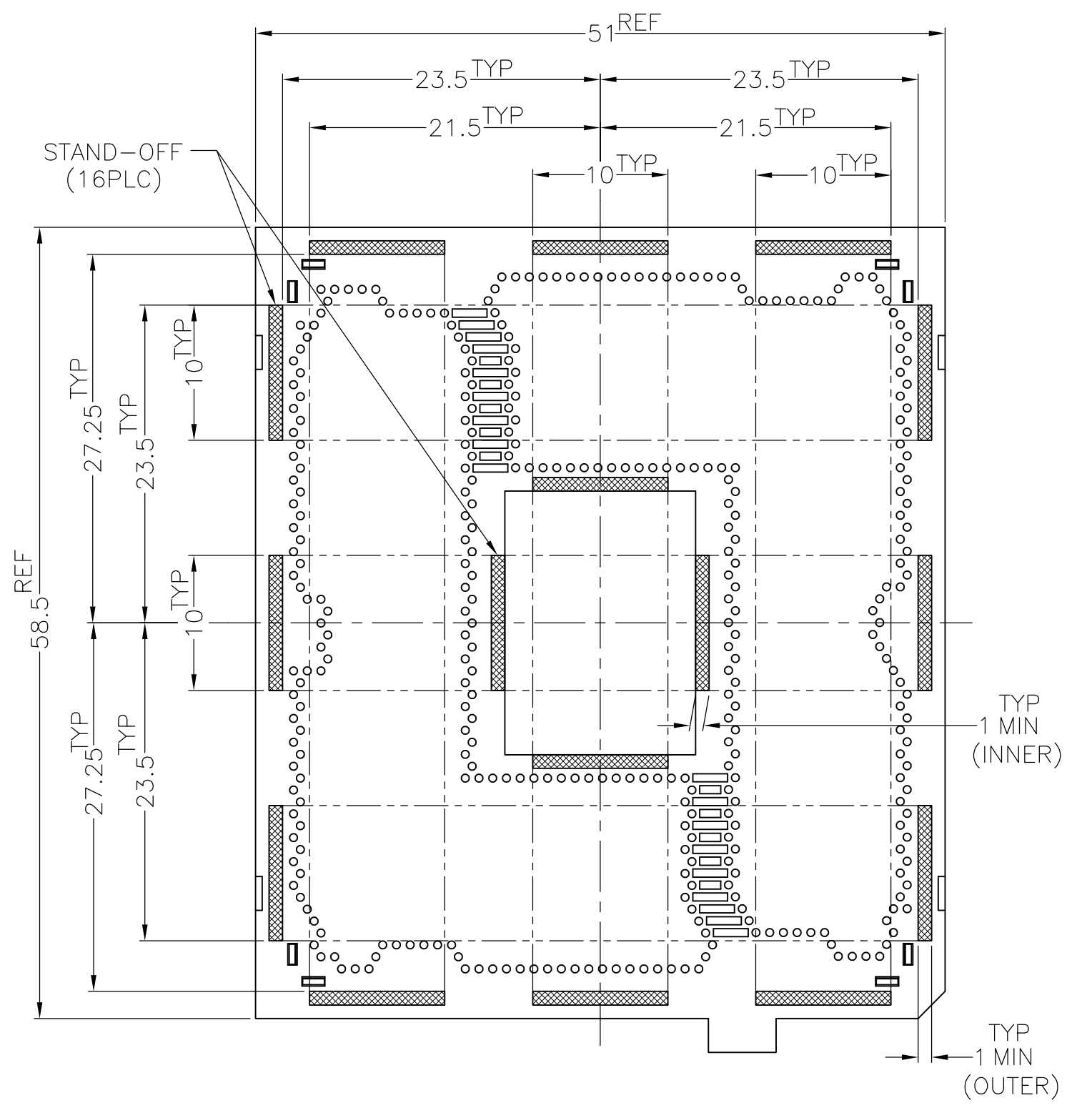
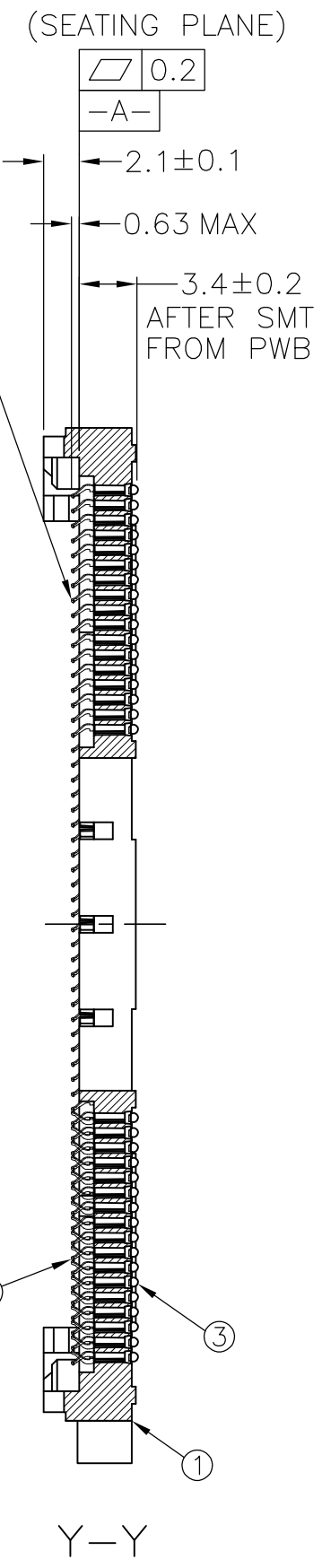
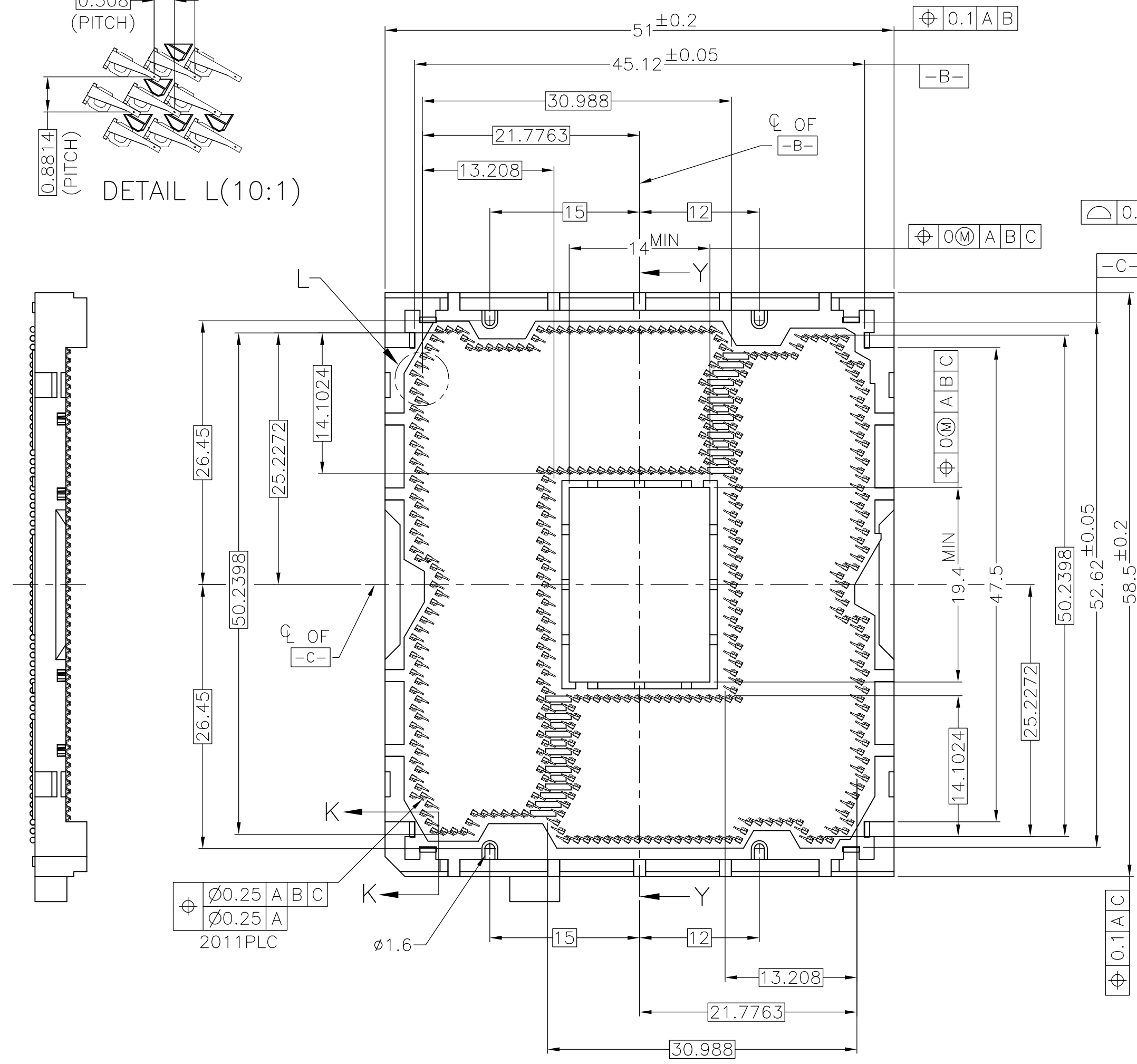
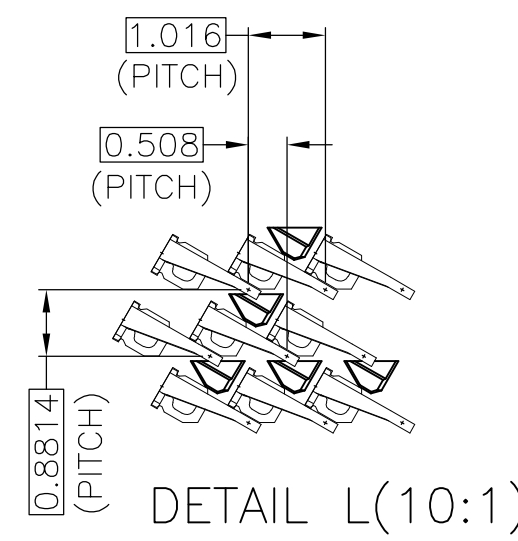

THESE VIEWS DON'T SHOW CAP

K-K (4:1)
 DATUM WALL CHAMFER
 8 LOCATIONS

THIS DRAWING IS A CONTROLLED DOCUMENT.		DWN	TE Connectivity	
DIMENSIONS: 單位: 毫米 mm		CHK	SOCKET ASSY LGA2011-0	
TOLERANCES UNLESS OTHERWISE SPECIFIED: 一般公差		APVD	SIZE	CAGE CODE
⊕ PLG	±0.3	PRODUCT SPEC	A2	00779
+ PLG	±3'	APPLICATION SPEC	DRAWING NO	1554653
⊕ PLG	±3'	取付適用規格	SCALE	NTS
⊕ PLG	±3'	FINISH 仕上	SHEET	3 OF 6
⊕ PLG	±3'	WEIGHT	REV	F2
MATERIAL 材料		CUSTOMER DRAWING		RESTRICTED TO

THIS DRAWING IS UNPUBLISHED. RELEASED FOR PUBLICATION APR , 2011.
 © COPYRIGHT 2011 By Tyco Electronics Japan G.K. ALL RIGHTS RESERVED.

LOC		DIST		REVISIONS			
J	-	P	LTR	DESCRIPTION	DATE	DWN	APVD
		-	-	SEE SHEET 1	-	-	-

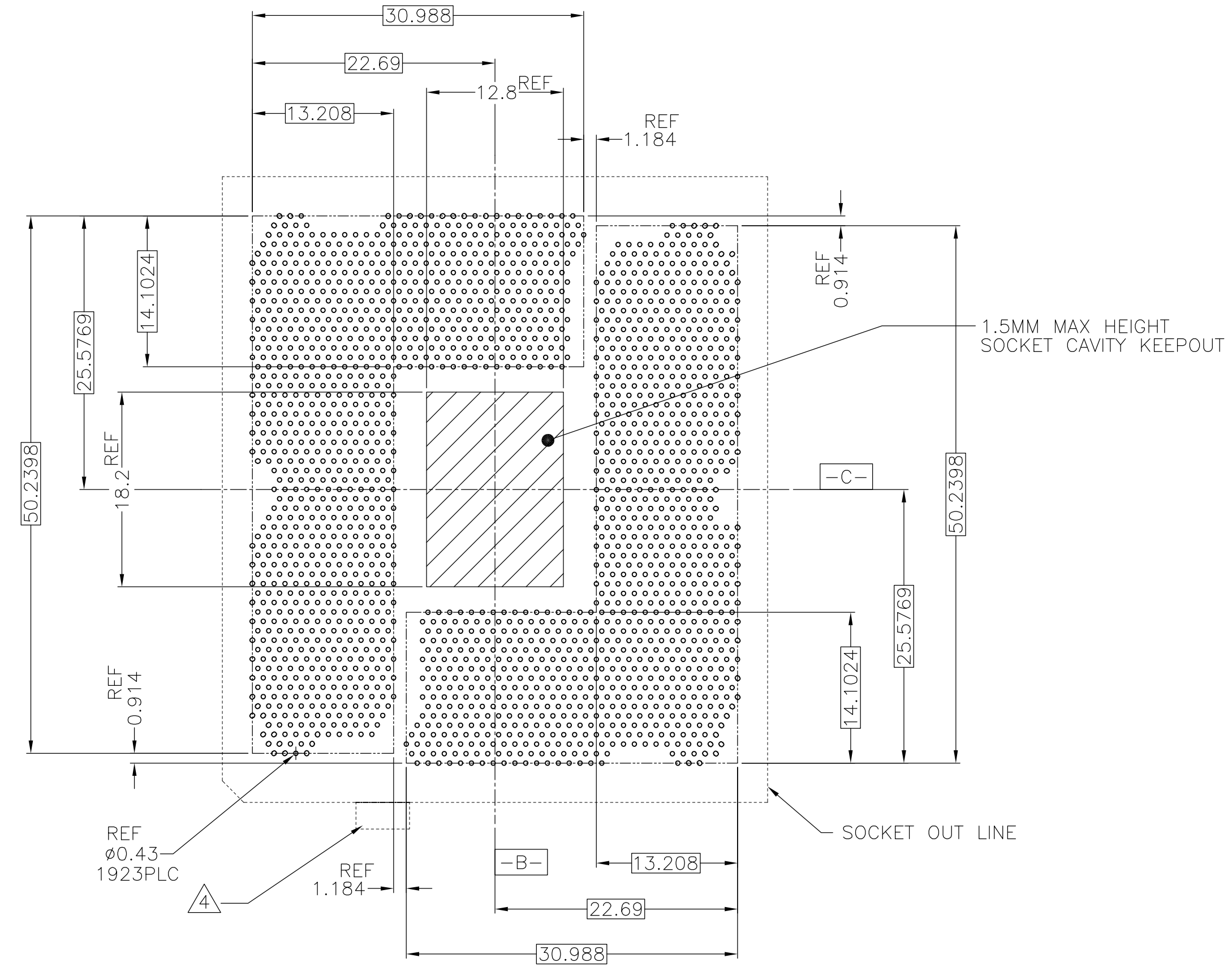

REFERENCE PATTERN LAYOUT

FOR GENERAL BOARD DESIGN, PLEASE REFER TO THE THERMAL AND MECHANICAL DESIGN GUIDELINES(TMDG) PROVIDED BY INTEL CORPORATION

THIS DRAWING IS A CONTROLLED DOCUMENT.		DWN	-	STE TE Connectivity	
DIMENSIONS: 单位: 毫米 mm		CHK	-		
TOLERANCES UNLESS OTHERWISE SPECIFIED: 一般公差		APVD	-	NAME 名称	
0-PLC ± 0.3		PRODUCT SPEC 製品規格		SOCKET ASSY	
1-PLC ± 3'		APPLICATION SPEC 取付適用規格		LGA2011-0	
2-PLC ± 3'		WEIGHT		SIZE	A2
3-PLC ± 3'		CUSTOMER DRAWING		CAGE CODE	00779
4-PLC ± 3'		SCALE 尺度		DRAWING NO 番号	C=1554653
FINISH 仕上		RESTRICTED TO		-	
MATERIAL 材料		SCALE 尺度		SHEET	4 of 6
		REV		F2	

LOC	DIST	REVISIONS				
J	-	P	LTR	DATE	DWN	APVD
		DESCRIPTION				
		SEE SHEET 1				

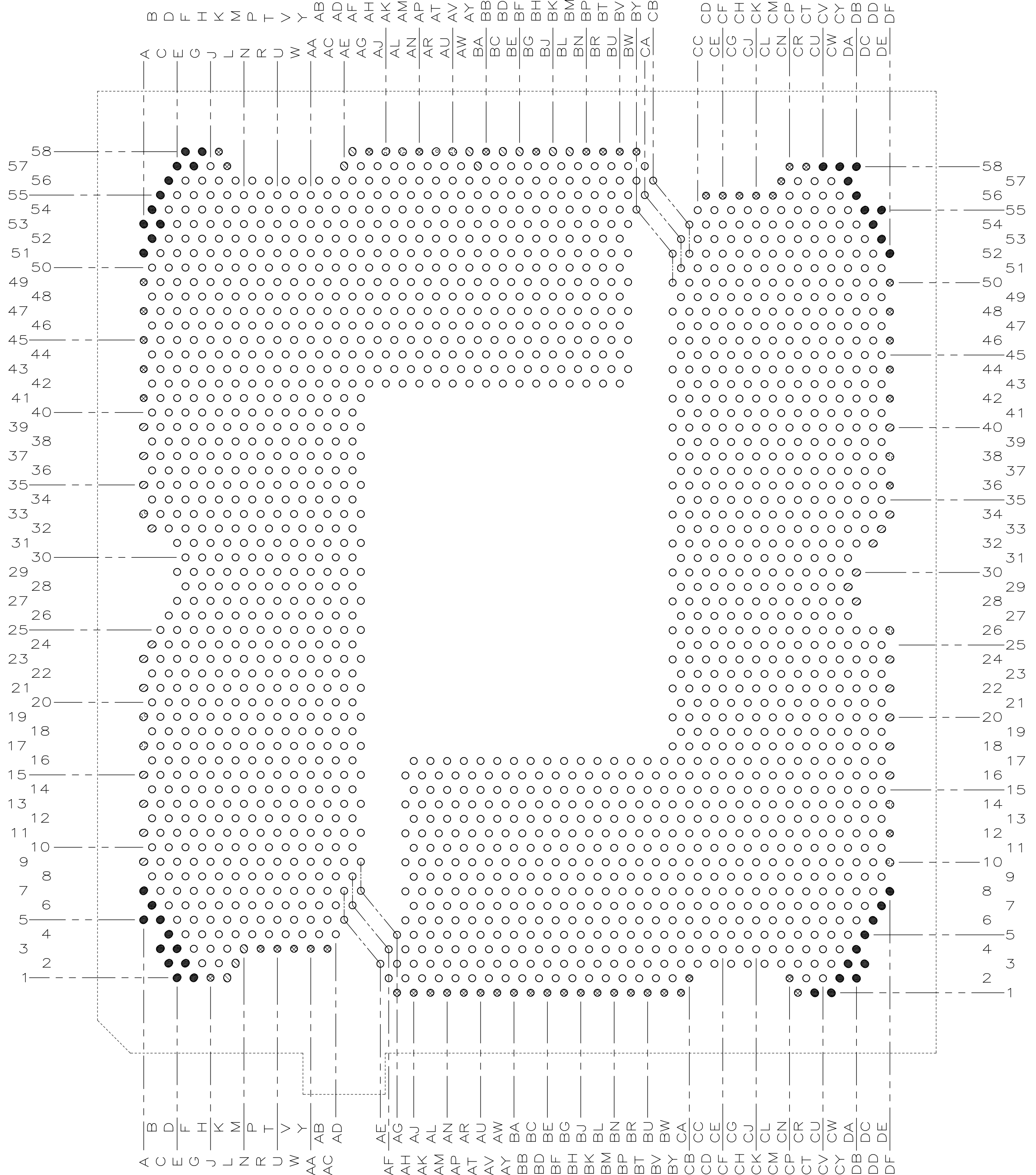

NOTE(APPLIED TO SHEET 5 OF 5):

- ⚠️ NON-CRITICAL TO FUNCTION PADS IN THE FOUR CORNER:
0.43X0.51 OBLONG SMD(SOLDER MASK DEFINED) PAD WHICH IS ORIENTED AT 45° TO THE SOCKET EDGE. THE PAD END CLOSEST TO THE CENTER OF THE SOCKET SHOULD HAVE $\phi 0.43 \pm 0.025$ SRO(SOLDER RESIST OPENING) WHICH IS A CRITICAL TO FUNCTION DIMENSION.
- ⚠️ CRITICAL TO FUNCTION PADS ORIENTED AT 90°:
0.43X0.51 OBLONG SMD PAD WHICH IS ORIENTED AT 90° TO THE SOCKET EDGE. THE PAD END CLOSEST TO THE CENTER OF THE SOCKET SHOULD HAVE $\phi 0.43 \pm 0.025$ SRO.
- ⚠️ CRITICAL TO FUNCTION PADS ORIENTED AT 45°:
0.43X0.51 OBLONG SMD PAD WHICH IS ORIENTED AT 45° TO THE SOCKET EDGE. THE PAD END CLOSEST TO THE CENTER OF THE SOCKET SHOULD HAVE $\phi 0.43 \pm 0.025$ SRO.
- ⚠️ CRITICAL TO FUNCTION PADS EXCEPT FOR DEFINED IN ⚠️ 3 :
CIRCULAR MD(METAL DEFINED) OR SMD IF POWER/GROUND PAD IN A FLOOD PLANE. $\phi 0.43 \pm 0.025$ SRO. FOR MD PADS ONLY A THICK TRACE 0.25 MIN WIDTH ⚠️ NO GREATER THAN 0.43.
- ⚠️ ALL PADS EXCEPT FOR DEFINED IN ⚠️ ⚠️ ⚠️ ⚠️ :
CIRCULAR MD PAD WITH $\phi 0.43 \pm 0.025$ SRO

MARK	DESCRIPTION	LOCATION ID	PAD
	⚠️ NON-CRITICAL TO FUNCTION PADS IN THE FOUR CORNER (43PCS)	A53,B54,C55,D56,E57,F58,A51,B52 C53,G57,H58,CU1,CW1,CY2DA3,DB4 DC5,DD6,DE7,DF8,DB2,DC3,E1,D2, C3,A5,G1,F2,E3,D4,C5,B6,A7,DF52, DE53,DD54,DC55,DB56,DA57,CY58, CV58,DE55,DB58	THICK TRACE SRO ± 0.025 $\phi 0.43$ 0.43 REF 0.51 REF 0.25 MIN
	⚠️ CRITICAL TO FUNCTION PADS ORIENTED AT 90° (34PCS)	L1,M2,N3,AE57,AF58,AY58,BA57 BD58,BF58,BK58,BM58,DF40,DF34 DE33,DD32,DB30,DA29,DB28,DF24 DF22,DF20,DF18,DF16,A9,A11,A13 A15,A21,A23,B24,B32,A35,A37,A39	SMD PAD
	⚠️ CRITICAL TO FUNCTION PADS ORIENTED AT 45° (11PCS)	AM58,AV58,DF38,DF26,DF14,DF10 A33,A19,A17,AK58,AT58	
	⚠️ CRITICAL TO FUNCTION PADS EXCEPT FOR DEFINED IN ⚠️ ⚠️ (57PCS)	CT58,CP58,CN57,CM56,CK56,CH56 CF56,CD56,BY58,BV58,BT58,BP58 BH58,BB58,AP58,AH58,K58,L57,J1 R3,U3,W3,AA3,AC3,AG1,AJ1,AL1,AN1 AR1,AU1,AW1,BA1,BC1,BE1,BG1,BJ1 BL1,BN1,BR1,BU1,BW1,CA1,CB2,CP2 CR1,A49,A47,A45,A43,A41,DF12 DF36,DF42,DF44,DF46,DF48,DF50	MD OR SMD PAD $\phi 0.43 \pm 0.025$
	⚠️ ALL PADS EXCEPT FOR DEFINED IN ⚠️ ⚠️ ⚠️ ⚠️	ALL PADS EXCEPT FOR DEFINED IN ⚠️ ⚠️ ⚠️ ⚠️	MD PAD $\phi 0.43 \pm 0.025$

FOR GENERAL BOARD DESIGN, PLEASE REFER TO THE THERMAL AND MECHANICAL DESIGN GUIDELINES(TMDG) PROVIDED BY INTEL CORPORATION

THIS DRAWING IS A CONTROLLED DOCUMENT.		DWN	TE Connectivity	
DIMENSIONS: 単位: 寸 mm		CHK	NAME 名称	
TOLERANCES UNLESS OTHERWISE SPECIFIED: 一般公差		APVD	SOCKET ASSY LGA2011-0	
0-PLG ±		PRODUCT SPEC	SIZE	CAGE CODE
1-PLG ±		製品規格	A2	00779
2-PLG ±		APPLICATION SPEC	DRAWING NO	RESTRICTED TO
3-PLG ±		取付適用規格	C=1554653	-
4-PLG ±		ANGLES	SCALE	SHEET
MATERIAL 材料		FINISH 仕上	NTS	5 of 6
WEIGHT		CUSTOMER DRAWING	REV	F2

LOC	DIST	REVISONS			DATE	DWN	APVD
		P	LTR	DESCRIPTION			
J	-	-	-	SEE SHEET 1	-	-	-

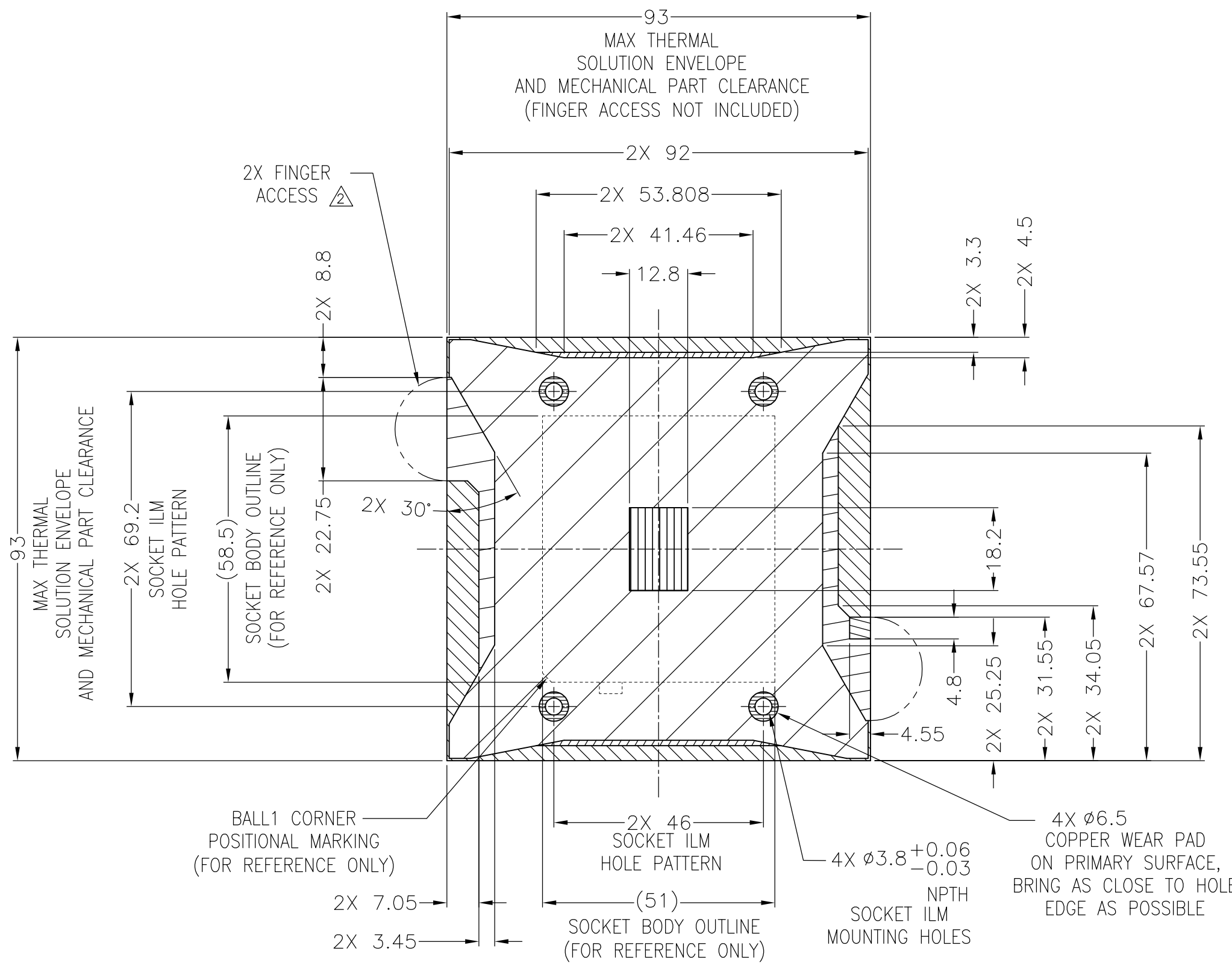

FOR ILM ASSY WIDE TYPE

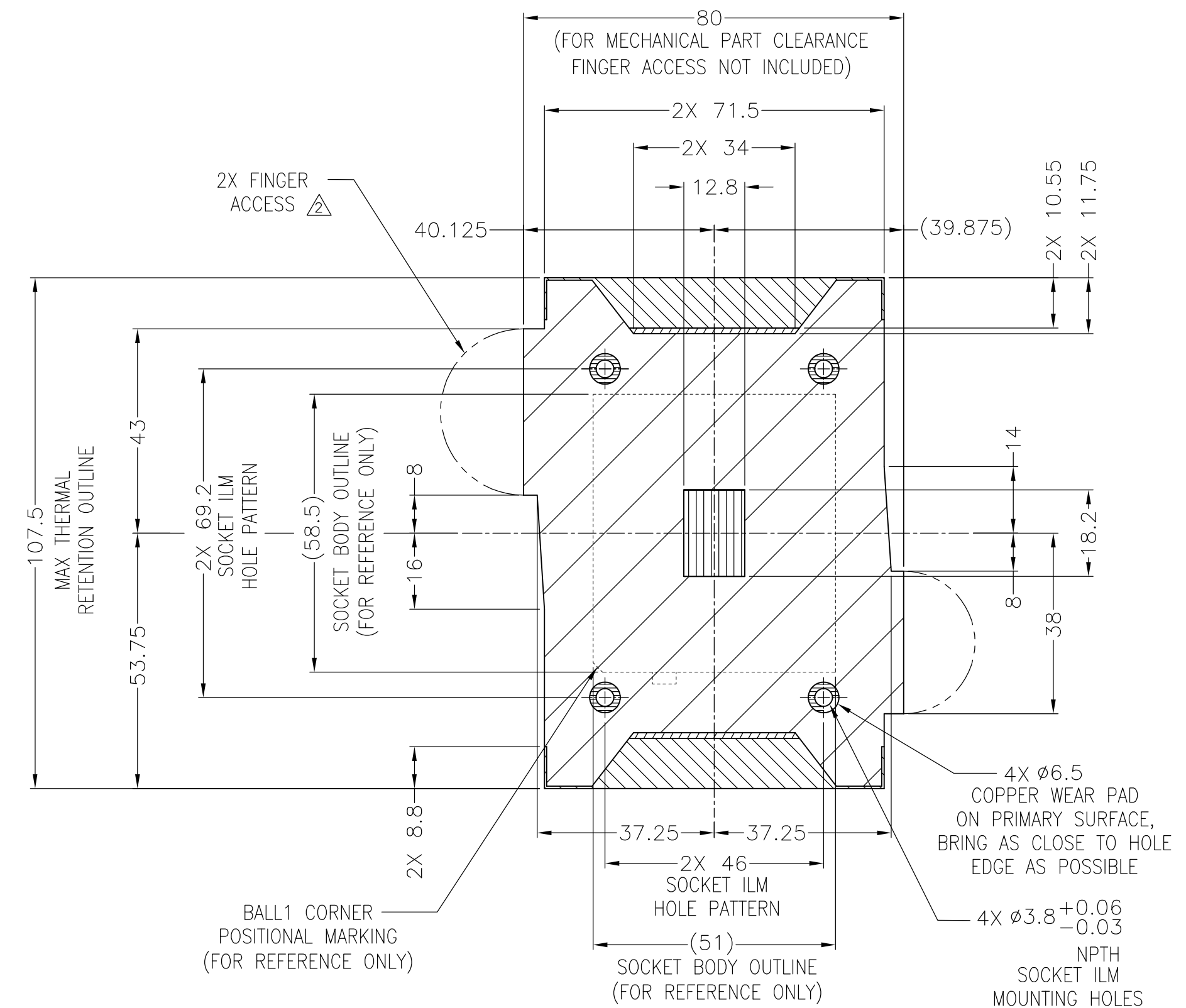

FOR ILM ASSY NARROW TYPE

COMPONENT KEEP-INS AND MECHANICAL COMPONENT KEEP-OUTS
 FOR REFERENCE ONLY, PLEASE REFER TO THE THERMAL AND MECHANICAL DESIGN GUIDELINES(TMDG) PROVIDED BY INTEL CORPORATION

NOTES (APPLIED TO SHEET 6 OF 6):
 1. DIMENSIONS STATED IN MILLIMETERS AND DEFINE ZONES, FOR UNDEFINED DIMENSIONS, REFER TO THERMAL AND MECHANICAL DESIGN GUIDELINE PROVIDED BY INTEL CORPORATION.
 △ SIZE & HEIGHT OF FINGER ACCESS TO BE DETERMINED BY SYSTEM/BOARD ARCHITECT. THIS IS ILM MECHANICAL CLEARANCE ONLY AND FINGER AND/OR TOOL ACCESS SHOULD BE DETERMINED SEPARATELY.

LEGEND

	0.0MM MAX COMPONENT HEIGHT, NO COMPONENT PLACEMENT, SOCKET, ILM, AND FINGER ACCESS KEEPIN ZONE
	7.2MM MAX COMPONENT HEIGHT.
	0.0MM MAX COMPONENT HEIGHT, NO COMPONENT PLACEMENT, NO ROUTE ZONE
	1.67MM MAX COMPONENT HEIGHT AFTER REFLOW 1.50MM MAX (MMC) COMPONENT HEIGHT BEFORE REFLOW
	1.6MM MAX COMPONENT HEIGHT.
	1.5MM MAX COMPONENT HEIGHT.
	1.9MM MAX COMPONENT HEIGHT.

THIS DRAWING IS A CONTROLLED DOCUMENT.

DWN: -
CHK: -
APVD: -

NAME: SOCKET ASSY LGA2011-0

SIZE: A2 CAGE CODE: 00779 DRAWING NO: 1554653

RESTRICTED TO: -

SCALE: NTS SHEET: 6 OF 6 REV: F2

PRODUCT SPEC: 製品規格
APPLICATION SPEC: 取付適用規格

WEIGHT: -

CUSTOMER DRAWING

X-ON Electronics

Largest Supplier of Electrical and Electronic Components

Click to view similar products for IC & Component Sockets category:

Click to view products by TE Connectivity manufacturer:

Other Similar products are found below :

[714-43-102-31-012000](#) [0066-3-17-15-30-14-02-0](#) [0134-0-15-15-32-27-04-0](#) [614-DG5](#) [6527-0-00-15-00-00-03-0](#) [670](#) [672](#) [673](#) [712-93-120-41-001000](#) [714-93-104-31-018000](#) [8059-4G1-LF](#) [807-22-001-10-001101](#) [807-22-001-10-003101](#) [807-22-001-10-004101](#) [807-22-001-10-006101](#) [807-22-001-30-011101](#) [807-22-001-30-012101](#) [807-22-001-30-013101](#) [807-22-001-30-014101](#) [8-1437531-4](#) [8150-6P10](#) [833-93-034-10-001000](#) [835-43-014-10-001000](#) [851-41-006-10-001000](#) [851-43-008-20-001000](#) [851-43-014-20-001000](#) [851-93-006-20-001000](#) [851-93-010-20-001000](#) [853-43-020-10-001000](#) [86.010.0053.0](#) [116-43-306-41-003000](#) [116-43-308-41-007000](#) [116-87-308-41-007101](#) [PX-68LCC](#) [PX-84LCC](#) [121-13-318-41-001000](#) [121-13-320-41-001000](#) [121-13-308-41-001000](#) [123-43-314-41-801000](#) [123-43-420-41-001000](#) [123-43-636-41-001000](#) [123-87-320-41-001101](#) [122-13-316-41-001000](#) [123-13-624-41-001000](#) [123-43-306-41-001000](#) [123-43-322-41-801000](#) [123-43-428-41-001000](#) [123-43-624-41-001000](#) [12-3513-11](#) [123-91-320-41-001000](#)