

THIS COPY IS PROVIDED ON A RESTRICTED BASIS AND IS NOT TO BE USED IN ANY WAY DETRIMENTAL TO THE INTERESTS OF PANDUIT CORP.

(4) 38 [1.5] X 127 [5]
PASS THRU OPENINGS
PER SIDE FOR 42-48RU
APPLICATIONS

(5) 38 [1.5] X 127 [5]
PASS THRU OPENINGS
PER SIDE FOR 51RU
APPLICATIONS

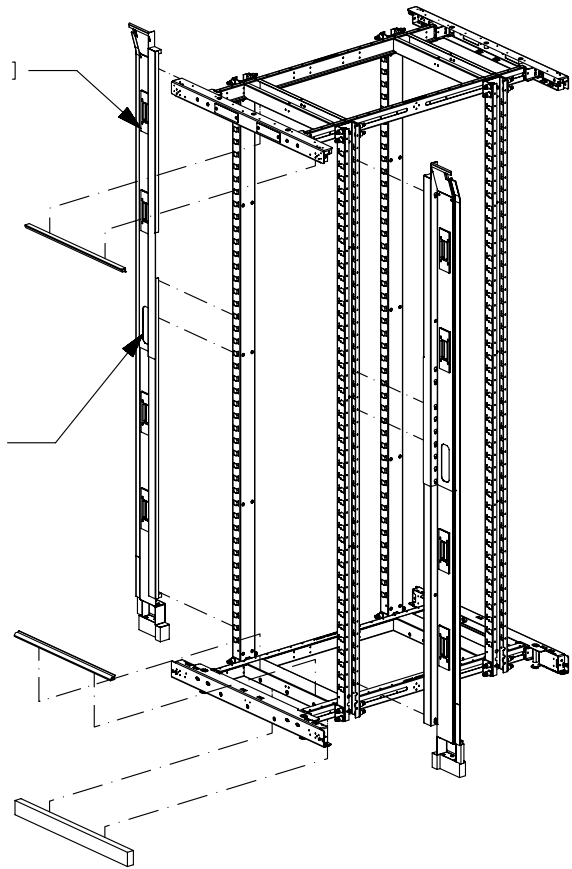

NOTE:
(2) ADDITIONAL CABLE
PROTECTION BEZELS,
CTCN1X5, TO BE PURCHASED
SEPARATELY WHEN NVBP IS
EXPANDED TO 51RU.

APPLICATION VIEW -
CABINET NOT INCLUDED

PANDUIT PART NO.	WEIGHT
NVBP	18.8 LBS/EACH 8.5 Kg/EACH

- VISIT OUR ON-LINE CATALOG AT WWW.PANDUIT.COM FOR A LIST OF CURRENT PARTS APPLICABLE FOR USE WITH THIS PRODUCT.
- DIMENSIONS IN PARENTHESSES ARE INCHES [in].
- VERTICAL BLANKING PANELS BLOCK BYPASS AIR AND DIRECT COLD AIRFLOW THROUGH EQUIPMENT.
- PARTS SUPPLIED:
1- 42-51RU RIGHT VERTICAL BLANKING PANEL
1- 42-51RU LEFT VERTICAL BLANKING PANEL
1- HARDWARE AND SEAL KIT
1- INSTRUCTION SHEET
- FULLY BONDED STRUCTURE WHEN ASSEMBLED PER INSTRUCTIONS.
- COMPATIBLE WITH CTGN1X5 COOL BOOT.

REV	DATE	BY	CHK	APR	DESCRIPTION	ECN
04A	10-10-14	ROJC	ROJC	TCN	UPDATED MODEL	12V343CT_DC

TITLE		VERTICAL BLANKING PANELS FOR N-TYPE CABINETS NVBP	
CUSTOMER DRAWING			
ITEM REVISION NAME	12V343CT/04	PANDUIT	
DATASET FILE NAME	12V343CT_DC/04A		
UNLESS OTHERWISE SPECIFIED, DIMENSIONAL TOLERANCES ARE:		MATERIAL:	N/A
DRAWING NUMBER:		12V343CT_DC	
DRAWN BY	DATE	CHK	SCALE
TWV	12-14-12	BSN	NONE
SHT 1 OF 2		SIZE	
		A	

X-ON Electronics

Largest Supplier of Electrical and Electronic Components

Click to view similar products for [Racks & Rack Cabinets](#) category:

Click to view products by [Panduit](#) manufacturer:

Other Similar products are found below :

[1440-0131-78](#) [1440-0132-78](#) [1440-0133-36](#) [AX103928](#) [5231308-07](#) [C2FSKKBK1](#) [UPS 525-17-9 PLAIN](#) [UPS 350-17-12 PLAIN](#) [UNC-3-7-5-PLAIN](#) [UNC-23/4-6-6-PLAIN](#) [SN8VCMW](#) [R4PCNWH](#) [R4PWH](#) [R4P36CNWH](#) [R4P36WH](#) [NAKIT2.0G5-B](#) [RACK-2.18](#) [RACK-3.18](#) [SR14UBDP](#) [SR42UBDP48](#) [SR48UBDP48](#) [1440-0131-84](#) [UPS350 12-14 SEMI-GLOSS BLK](#) [UPH 350-12-14-BT](#) [UPR 525-17-14](#) [BLU/WHT](#) [RM1908BKVP](#) [RM2U19BKFP](#) [DN-WD19 12U/600](#) [1564A2BK1](#) [895-39949](#) [5231304-07](#) [18P3317](#) [18P4545](#) [HCT302411H](#) [HCT362011H](#) [HCT363011H](#) [HCT363611H](#) [HCT482411H](#) [HCT483011H](#) [HCT483611H](#) [HCT484814H](#) [1UHD722918N4SS](#) [RM3U19BKFP](#) [RM2U1918SBK](#) [2CLD83643](#) [2CLD84843](#) [2CLT204843](#) [RB-2PA1945NF](#) [RB-2PA1945BK](#) [RB-2PA2345NF](#)