

THIS DRAWING IS UNPUBLISHED. RELEASED FOR PUBLICATION  
 © COPYRIGHT - Tyco Electronics Japan G.K. ALL RIGHTS RESERVED.

REVISIONS					
P	LTR	DESCRIPTION	DATE	DWN	APVD
C1		REVISED	07APR2016	H.F	A.K

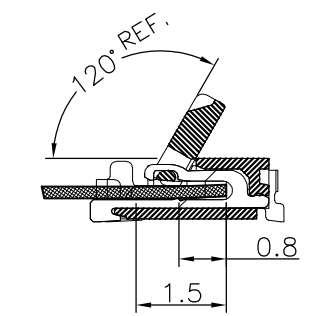

- 1 MATERIAL : HOUSING : LCP, UL94V-0, BLACK  
 ACTUATOR : LCP, UL94V-0, NATURAL  
 CONTACT&PEG : PHOSPHOR BRONZE
- 2 FINISH : CONTACT : GOLD FLASH PLATED ON CONTACT AREA AND SOLDER TAIL, WITH ENTIRE CONTACT UNDER PLATED 1.27 μm[50 μ"]MIN. NICKEL.  
 PEG : GOLD FLASH PLATED OVER 1.27 μm[50 μ"]MIN. NICKEL.
- 3 REFLOW SOLDER CAPABLE TO 260°C PER TEC-109-201, CONDITION B.
- 4 SUBSTANCE RESTRICTIONS FOR LOW HALOGEN (BY WEIGHT)
  - BROMINE(Br) ≤ 900ppm(0.09%)
  - CHLORINE(Cl) ≤ 900ppm(0.09%)
  - TOTAL CONCENTRATION OF Cl+Br ≤ 1500ppm(0.15%)

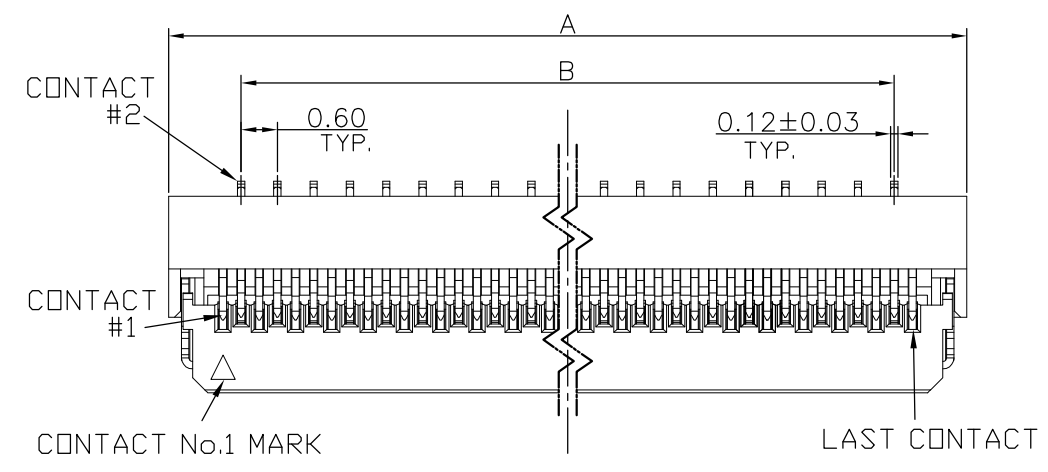
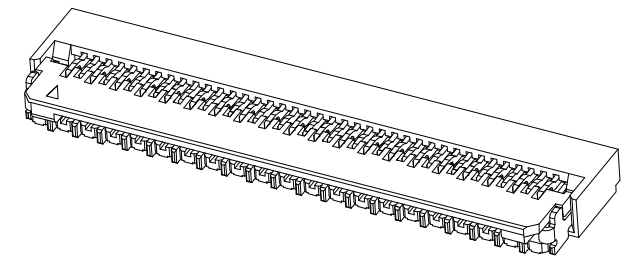
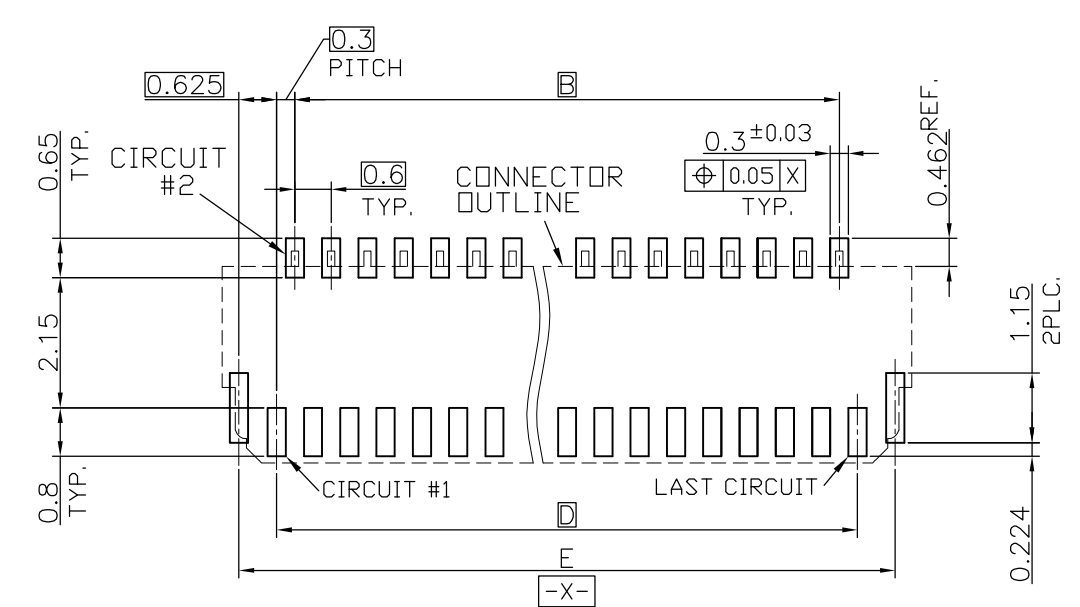
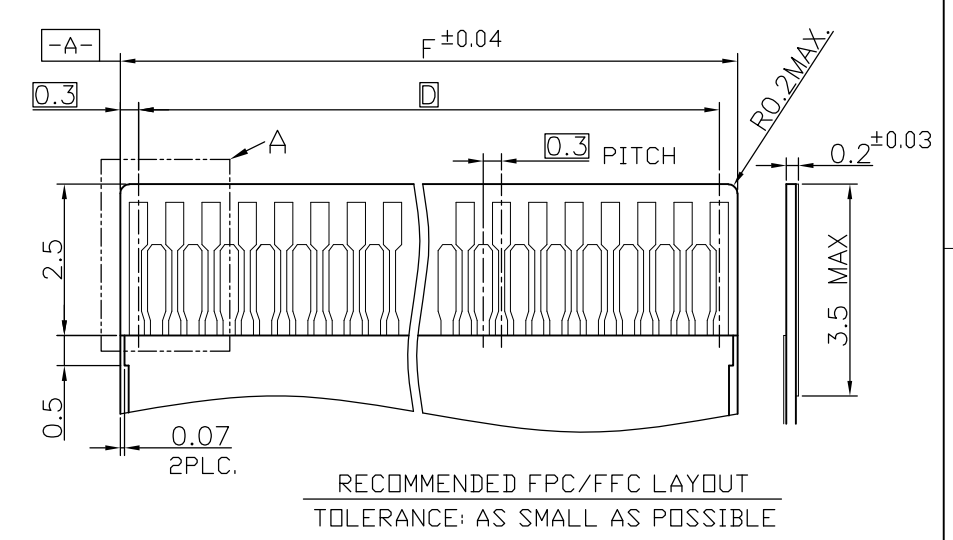
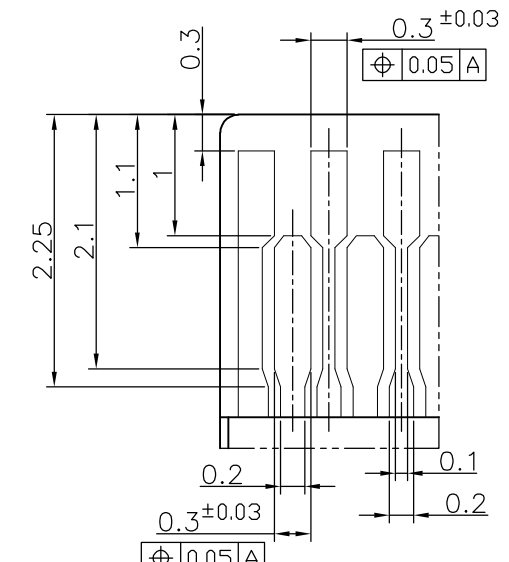
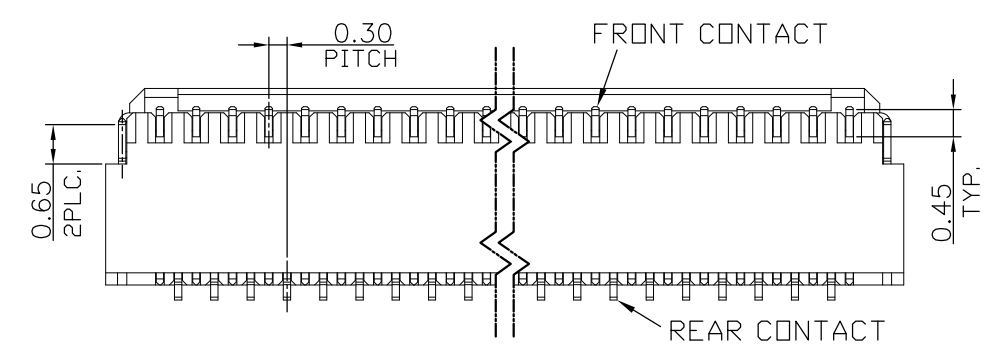
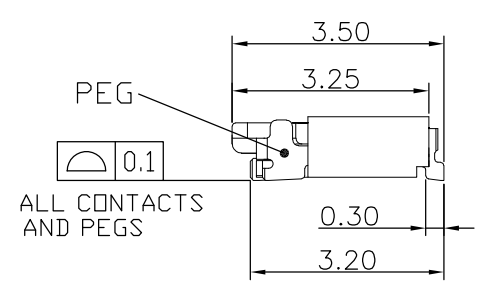
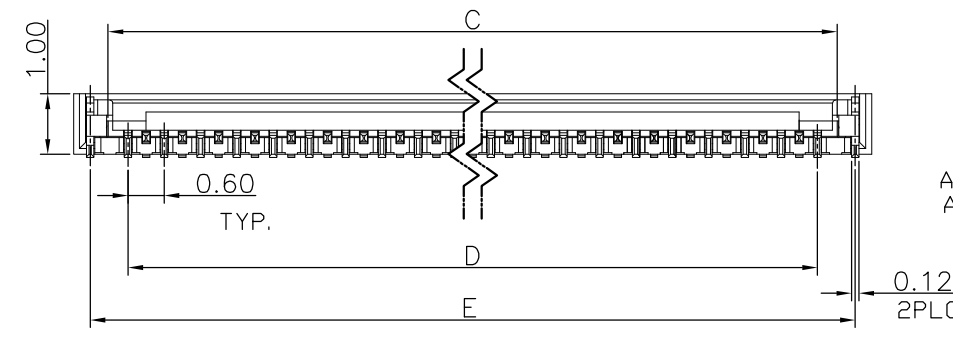

21.60	22.25	21.00	21.65	20.40	22.80	71	7-2041390-1
15.60	16.25	15.00	15.65	14.40	16.80	51	5-2041390-1
13.80	14.45	13.20	13.85	12.60	15.00	45	4-2041390-5
12.00	12.65	11.40	12.05	10.80	13.20	39	3-2041390-9
F	E	D	C	B	A	No. OF CONTACTS	PART NUMBER

THIS DRAWING IS A CONTROLLED DOCUMENT.		DWN A.WU 15JUN2011	<b>STE</b> TE Connectivity	
DIMENSIONS: mm		CHK S.CHEN 15JUN2011		
TOLERANCES UNLESS OTHERWISE SPECIFIED:		APVD W.KODAMA 15JUN2011	NAME	
0 PLC ± -		PRODUCT SPEC		FPC CONNECTOR, 0.3 PITCH ZIF, BOTTOM CONTACT
1 PLC ± 0.3		APPLICATION SPEC		
2 PLC ± 0.2		108-57877		SIZE
3 PLC ± 0.15		CUSTOMER DRAWING		CAGE CODE
4 PLC ± -		WEIGHT		DRAWING NO
ANGLES ± -		A300779		RESTRICTED TO
FINISH SEE NOTE		G=2041390		SCALE
MATERIAL SEE NOTE		CUSTOMER DRAWING		SHEET
		SCALE NTS		1 OF 2
		REV C1		

THIS DRAWING IS UNPUBLISHED.

RELEASED FOR PUBLICATION

© COPYRIGHT - Tyco Electronics Japan G.K.

ALL RIGHTS RESERVED.

REVISIONS

P	LTR	DESCRIPTION	DATE	DWN	APVD
-	-	SEE SHEET 1	-	-	-

NOTES:

- MATERIAL:  
BOX: FIBREBOARD, CORRUGATED, DOUBLE WALL.  
COVER TAPE: PET, 120°C, TRANSPARENT.  
CARRIER TAPE: POLYSTYRENES, TRANSPARENT.  
REEL: HIPS, BLUE COLOR.  
BAG: POLYETHYLENES, TRANSPARENT.
- EACH BAG SHALL BE INCLUDED DESICCANT.
- PEELING STRENGTH: 0.1 ~ 1.3 N (10 ~ 130 GRAMS).
- PEELING SPEED: 300 mm/min.

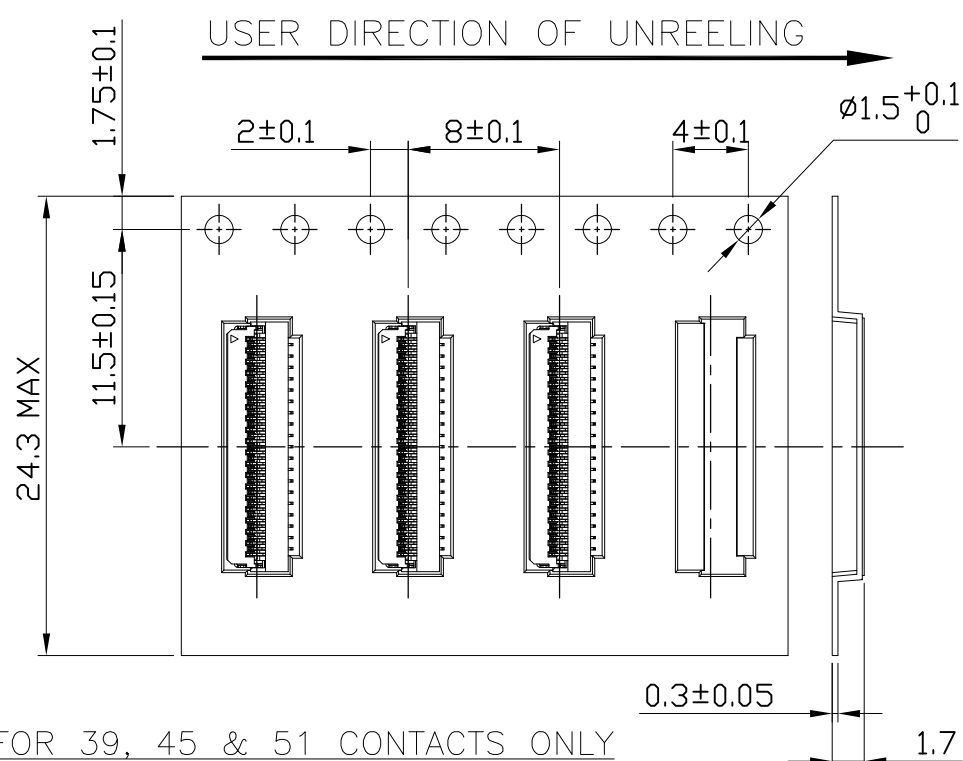
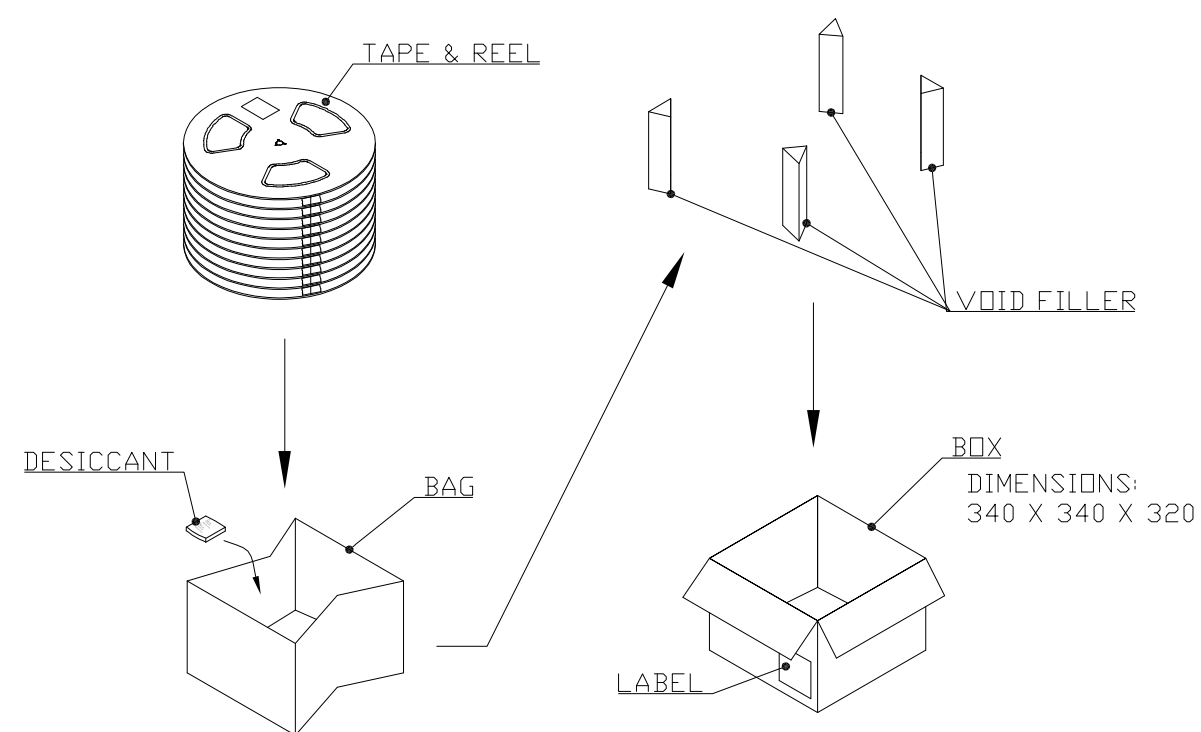
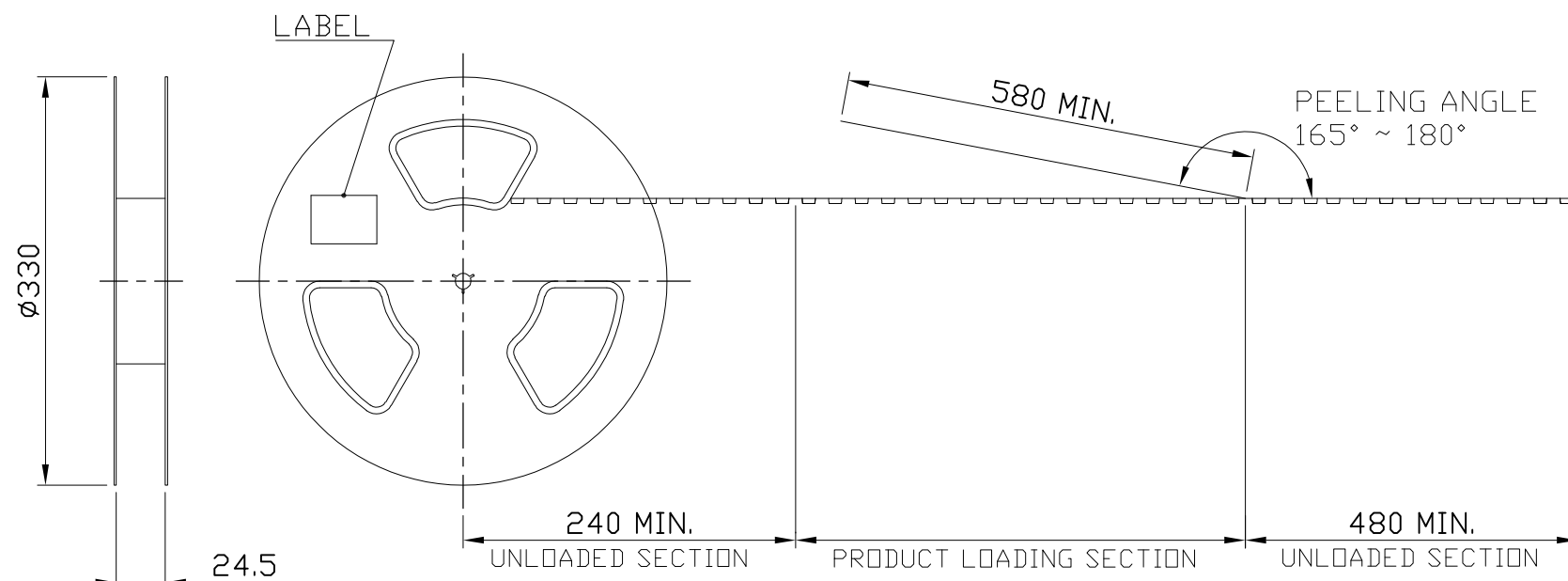

27000	6	4500	4.56	9.56	71
45000	10	4500	4.41	9.41	51
45000	10	4500	3.96	8.96	45
45000	10	4500	3.42	8.42	39
PCS /BOX	REELS /BOX	PCS /TAPE	N/W (kg)	G/W (kg)	No. OF CONTACT

THIS DRAWING IS A CONTROLLED DOCUMENT.		DWN	-				
DIMENSIONS: mm		CHK	-				
TOLERANCES UNLESS OTHERWISE SPECIFIED:		APVD	-				
0 PLC ± -		PRODUCT SPEC	-				
1 PLC ± -		APPLICATION SPEC	-				
2 PLC ± -		WEIGHT	-				
3 PLC ± -		SIZE	A3	CAGE CODE	00779	DRAWING NO	C-2041390
4 PLC ± -		RESTRICTED TO	-				
ANGLES ± -		SCALE	NTS		SHEET	2 OF 2	
FINISH		REV	C1				
MATERIAL		CUSTOMER DRAWING					



TE Connectivity

FPC CONNECTOR, 0.3 PITCH  
ZIF, BOTTOM CONTACT

## X-ON Electronics

Largest Supplier of Electrical and Electronic Components

*Click to view similar products for [FFC & FPC Connectors](#) category:*

*Click to view products by [TE Connectivity](#) manufacturer:*

Other Similar products are found below :

[HFW11R-1STE1H1LF](#) [FH29B-100S-0.2SHW\(99\)](#) [FA5S008HP1](#) [FH29B-120S-0.2SHW\(99\)](#) [FH29B-80S-0.2SHW\(99\)](#) [FHS-16](#) [FPH-2022G](#)  
[52610-1075](#) [52610-1275](#) [52610-1934](#) [XF3M\(1\)-1415-1B-R100](#) [501864-3091-TR225](#) [0525594033](#) [086210010340800](#) [086222026001800](#)  
[52271-2869-CUT-TAPE](#) [62674-201121DLF](#) [62684-36210E9ALF](#) [52610-1675](#) [52746-1671-TR250](#) [10051922-2810EHLF](#) [6-520415-9](#)  
[BD021-09A-A1-0350-0200-0550-LD](#) [SFV6R-1STE9HLF](#) [XF3M-2915-1B-R100](#) [1658549-1](#) [62674-221121ALF](#) [46214008010800](#)  
[046298003000883](#) [151660622](#) [842-816-2630-035](#) [AYF530665TA](#) [AYF351525](#) [046296011930846+](#) [AYF352325A](#) [046254020000800+](#)  
[FH19C-13S-0.5SH\(99\)](#) [FH39J-51S-0.3SHW\(99\)](#) [AYF355125A](#) [AYF530365TA](#) [FH29B-44S-0.2SHW\(99\)](#) [SFW5R-2STAE9LF](#) [AYF351125A](#)  
[AYF350725A](#) [62684-502100AHLF](#) [FH39-61S-0.3SHW\(99\)](#) [AYF414035A](#) [10064555-172520HLF](#) [AYF212335A](#) [504754-2500](#)