

74AVC1T45

Dual-supply voltage level translator/transceiver; 3-state

Rev. 6 — 20 April 2016

Product data sheet

1. General description

The 74AVC1T45 is a single bit, dual supply transceiver with 3-state output that enables bidirectional level translation. It features two 1-bit input-output ports (A and B), a direction control input (DIR) and dual supply pins ($V_{CC(A)}$ and $V_{CC(B)}$). Both $V_{CC(A)}$ and $V_{CC(B)}$ can be supplied at any voltage between 0.8 V and 3.6 V making the device suitable for translating between any of the low voltage nodes (0.8 V, 1.2 V, 1.5 V, 1.8 V, 2.5 V and 3.3 V). Pins A and DIR are referenced to $V_{CC(A)}$ and pin B is referenced to $V_{CC(B)}$. A HIGH on DIR allows transmission from A to B and a LOW on DIR allows transmission from B to A.

The device is fully specified for partial power-down applications using I_{OFF} . The I_{OFF} circuitry disables the output, preventing any damaging backflow current through the device when it is powered down. In suspend mode when either $V_{CC(A)}$ or $V_{CC(B)}$ are at GND level, both A and B are in the high-impedance OFF-state.

2. Features and benefits

- Wide supply voltage range:
 - ◆ $V_{CC(A)}$: 0.8 V to 3.6 V
 - ◆ $V_{CC(B)}$: 0.8 V to 3.6 V
- High noise immunity
- Complies with JEDEC standards:
 - ◆ JESD8-12 (0.8 V to 1.3 V)
 - ◆ JESD8-11 (0.9 V to 1.65 V)
 - ◆ JESD8-7 (1.2 V to 1.95 V)
 - ◆ JESD8-5 (1.8 V to 2.7 V)
 - ◆ JESD8-B (2.7 V to 3.6 V)
- ESD protection:
 - ◆ HBM JESD22-A114E Class 3B exceeds 8000 V
 - ◆ MM JESD22-A115-A exceeds 200 V
 - ◆ CDM JESD22-C101C exceeds 1000 V
- Maximum data rates:
 - ◆ 500 Mbit/s (1.8 V to 3.3 V translation)
 - ◆ 320 Mbit/s (< 1.8 V to 3.3 V translation)
 - ◆ 320 Mbit/s (translate to 2.5 V or 1.8 V)
 - ◆ 280 Mbit/s (translate to 1.5 V)
 - ◆ 240 Mbit/s (translate to 1.2 V)
- Suspend mode
- Latch-up performance exceeds 100 mA per JESD 78 Class II

- Inputs accept voltages up to 3.6 V
- Low noise overshoot and undershoot < 10 % of V_{CC}
- I_{OFF} circuitry provides partial Power-down mode operation
- Multiple package options
- Specified from $-40\text{ }^{\circ}\text{C}$ to $+85\text{ }^{\circ}\text{C}$ and $-40\text{ }^{\circ}\text{C}$ to $+125\text{ }^{\circ}\text{C}$

3. Ordering information

Table 1. Ordering information

Type number	Package			Version
	Temperature range	Name	Description	
74AVC1T45GW	$-40\text{ }^{\circ}\text{C}$ to $+125\text{ }^{\circ}\text{C}$	SC-88	plastic surface-mounted package; 6 leads	SOT363
74AVC1T45GM	$-40\text{ }^{\circ}\text{C}$ to $+125\text{ }^{\circ}\text{C}$	XSON6	plastic extremely thin small outline package; no leads; 6 terminals; body $1 \times 1.45 \times 0.5\text{ mm}$	SOT886
74AVC1T45GN	$-40\text{ }^{\circ}\text{C}$ to $+125\text{ }^{\circ}\text{C}$	XSON6	extremely thin small outline package; no leads; 6 terminals; body $0.9 \times 1.0 \times 0.35\text{ mm}$	SOT1115
74AVC1T45GS	$-40\text{ }^{\circ}\text{C}$ to $+125\text{ }^{\circ}\text{C}$	XSON6	extremely thin small outline package; no leads; 6 terminals; body $1.0 \times 1.0 \times 0.35\text{ mm}$	SOT1202
74AVC1T45GX	$-40\text{ }^{\circ}\text{C}$ to $+125\text{ }^{\circ}\text{C}$	X2SON6	plastic thermal extremely thin small outline package; no leads; 6 terminals; body $1 \times 0.8 \times 0.35\text{ mm}$	SOT1255

4. Marking

Table 2. Marking

Type number	Marking code ^[1]
74AVC1T45GW	B5
74AVC1T45GM	B5
74AVC1T45GN	B5
74AVC1T45GS	B5
74AVC1T45GX	B5

[1] The pin 1 indicator is located on the lower left corner of the device, below the marking code.

5. Functional diagram

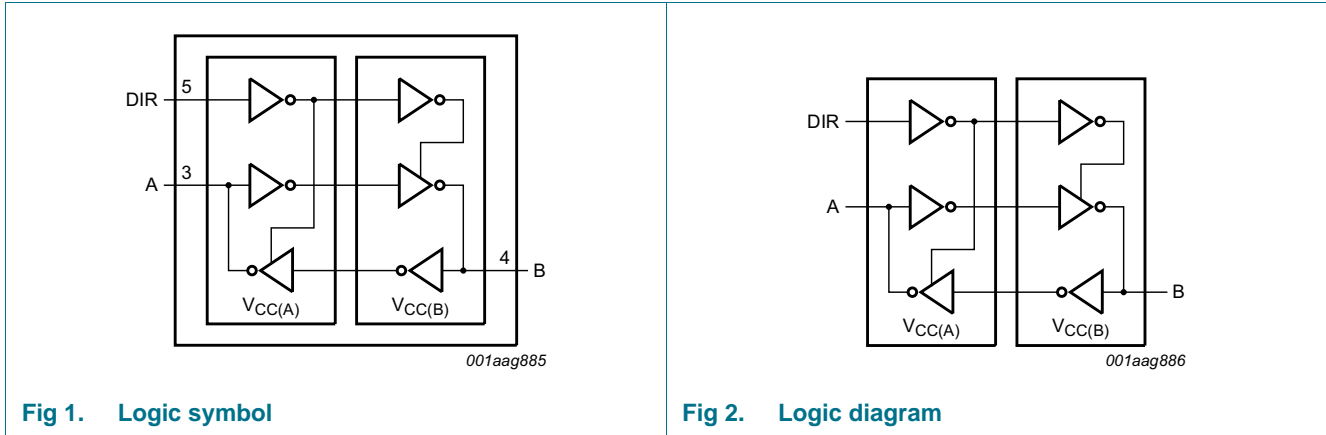

Fig 1. Logic symbol

Fig 2. Logic diagram

6. Pinning information

6.1 Pinning

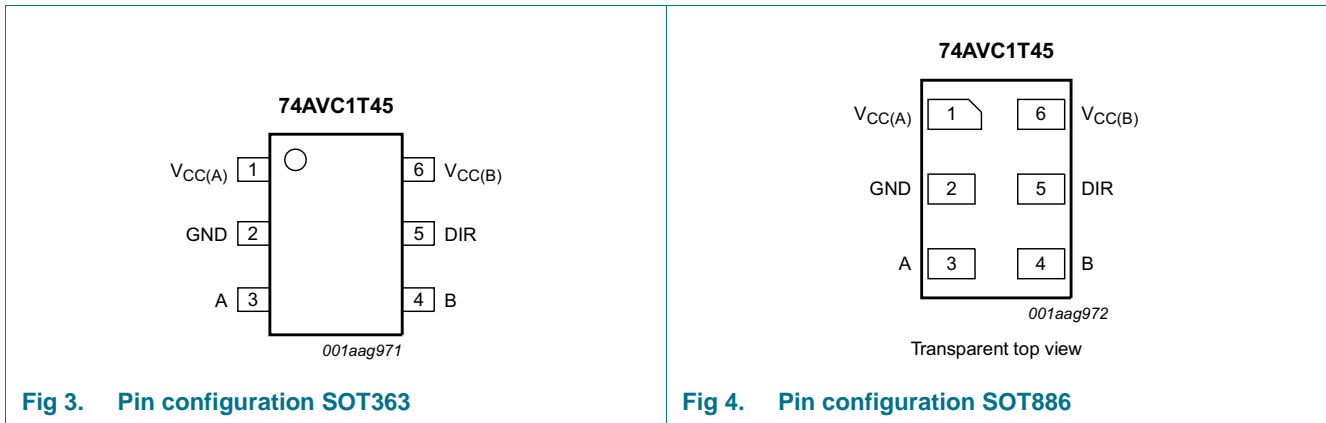

Fig 3. Pin configuration SOT363

Fig 4. Pin configuration SOT886

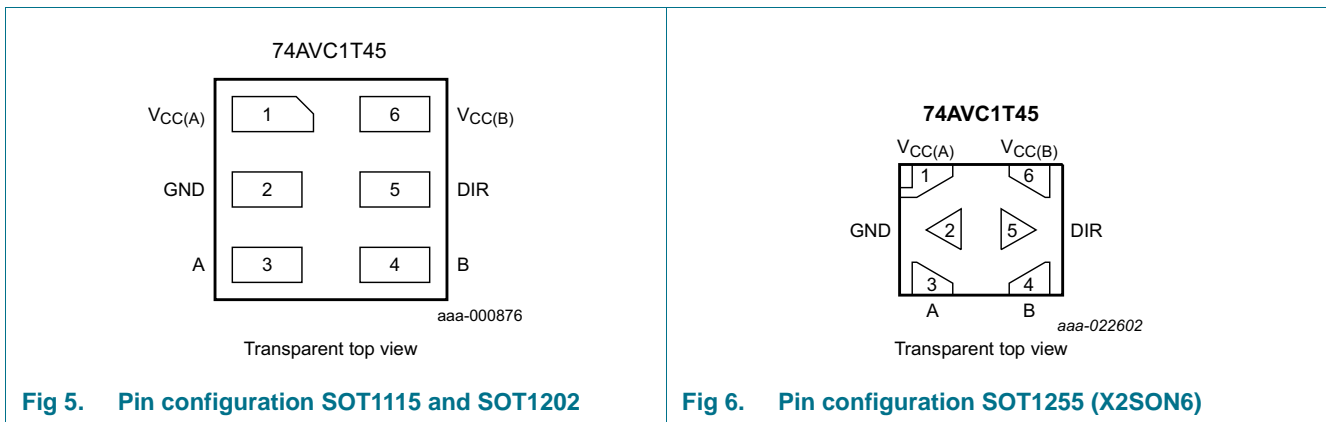

Fig 5. Pin configuration SOT1115 and SOT1202

Fig 6. Pin configuration SOT1255 (X2SON6)

6.2 Pin description

Table 3. Pin description

Symbol	Pin	Description
$V_{CC(A)}$	1	supply voltage port A and DIR
GND	2	ground (0 V)
A	3	data input or output
B	4	data input or output
DIR	5	direction control
$V_{CC(B)}$	6	supply voltage port B

7. Functional description

Table 4. Function table^[1]

Supply voltage	Input	Input/output ^[2]	
		A	B
$V_{CC(A)}, V_{CC(B)}$	DIR ^[3]	A = B	B = A
0.8 V to 3.6 V	L	A = B	input
0.8 V to 3.6 V	H	input	B = A
GND ^[4]	X	Z	Z

[1] H = HIGH voltage level; L = LOW voltage level; X = don't care; Z = high-impedance OFF-state.

[2] The input circuit of the data I/O is always active.

[3] The DIR input circuit is referenced to $V_{CC(A)}$.

[4] When either $V_{CC(A)}$ or $V_{CC(B)}$ is at GND level, the device goes into suspend mode.

8. Limiting values

Table 5. Limiting values

In accordance with the Absolute Maximum Rating System (IEC 60134). Voltages are referenced to GND (ground = 0 V).

Symbol	Parameter	Conditions	Min	Max	Unit
$V_{CC(A)}$	supply voltage A		-0.5	+4.6	V
$V_{CC(B)}$	supply voltage B		-0.5	+4.6	V
I_{IK}	input clamping current	$V_I < 0$ V	-50	-	mA
V_I	input voltage		-0.5	+4.6	V
I_{OK}	output clamping current	$V_O < 0$ V	-50	-	mA
V_O	output voltage	Active mode	-0.5	$V_{CCO} + 0.5$	V
		Suspend or 3-state mode	-0.5	+4.6	V
I_O	output current	$V_O = 0$ V to V_{CCO}	-	± 50	mA
I_{CC}	supply current	$I_{CC(A)}$ or $I_{CC(B)}$	-	100	mA
I_{GND}	ground current		-100	-	mA
T_{stg}	storage temperature		-65	+150	°C
P_{tot}	total power dissipation	$T_{amb} = -40$ °C to +125 °C	-	250	mW

[1] The minimum input voltage ratings and output voltage ratings may be exceeded if the input and output current ratings are observed.

[2] V_{CCO} is the supply voltage associated with the output port.

[3] $V_{CCO} + 0.5$ V should not exceed 4.6 V.

[4] For SC-88 packages: above 87.5 °C the value of P_{tot} derates linearly with 4.0 mW/K.

For X2SON6 and XSON6 packages: above 118 °C the value of P_{tot} derates linearly with 7.8 mW/K.

9. Recommended operating conditions

Table 6. Recommended operating conditions

Symbol	Parameter	Conditions	Min	Max	Unit
$V_{CC(A)}$	supply voltage A		0.8	3.6	V
$V_{CC(B)}$	supply voltage B		0.8	3.6	V
V_I	input voltage		0	3.6	V
V_O	output voltage	Active mode	0	V_{CCO}	V
		Suspend or 3-state mode	0	3.6	V
T_{amb}	ambient temperature		-40	+125	°C
$\Delta t/\Delta V$	input transition rise and fall rate	$V_{CCI} = 0.8$ V to 3.6 V	-	5	ns/V

[1] V_{CCO} is the supply voltage associated with the output port.

[2] V_{CCI} is the supply voltage associated with the input port.

10. Static characteristics

Table 7. Typical static characteristics at $T_{amb} = 25\text{ °C}$ [1][2]

At recommended operating conditions; voltages are referenced to GND (ground = 0 V).

Symbol	Parameter	Conditions	Min	Typ	Max	Unit
V_{OH}	HIGH-level output voltage	$V_I = V_{IH}$ or V_{IL}				
		$I_O = -1.5\text{ mA}$; $V_{CC(A)} = V_{CC(B)} = 0.8\text{ V}$	-	0.69	-	V
V_{OL}	LOW-level output voltage	$V_I = V_{IH}$ or V_{IL}				
		$I_O = 1.5\text{ mA}$; $V_{CC(A)} = V_{CC(B)} = 0.8\text{ V}$	-	0.07	-	V
I_I	input leakage current	DIR input; $V_I = 0\text{ V}$ or 3.6 V ; $V_{CC(A)} = V_{CC(B)} = 0.8\text{ V}$ to 3.6 V	-	± 0.025	± 0.25	μA
I_{OZ}	OFF-state output current	A or B port; $V_O = 0\text{ V}$ or V_{CCO} ; $V_{CC(A)} = V_{CC(B)} = 0.8\text{ V}$ to 3.6 V	[3]	± 0.5	± 2.5	μA
I_{OFF}	power-off leakage current	A port; V_I or $V_O = 0\text{ V}$ to 3.6 V ; $V_{CC(A)} = 0\text{ V}$; $V_{CC(B)} = 0.8\text{ V}$ to 3.6 V	-	± 0.1	± 1	μA
		B port; V_I or $V_O = 0\text{ V}$ to 3.6 V ; $V_{CC(B)} = 0\text{ V}$; $V_{CC(A)} = 0.8\text{ V}$ to 3.6 V	-	± 0.1	± 1	μA
C_I	input capacitance	DIR input; $V_I = 0\text{ V}$ or 3.3 V ; $V_{CC(A)} = V_{CC(B)} = 3.3\text{ V}$	-	1.0	-	pF
$C_{I/O}$	input/output capacitance	A and B port; Suspend mode; $V_O = V_{CCO}$ or GND; $V_{CC(A)} = V_{CC(B)} = 3.3\text{ V}$	-	4.0	-	pF

[1] V_{CCO} is the supply voltage associated with the output port.

[2] V_{CCI} is the supply voltage associated with the data input port.

[3] For I/O ports, the parameter I_{OZ} includes the input leakage current.

Table 8. Static characteristics [1][2]

At recommended operating conditions; voltages are referenced to GND (ground = 0 V).

Symbol	Parameter	Conditions	-40 °C to +85 °C		-40 °C to +125 °C		Unit
			Min	Max	Min	Max	
V_{IH}	HIGH-level input voltage	data input					
		$V_{CCI} = 0.8\text{ V}$	$0.70V_{CCI}$	-	$0.70V_{CCI}$	-	V
		$V_{CCI} = 1.1\text{ V}$ to 1.95 V	$0.65V_{CCI}$	-	$0.65V_{CCI}$	-	V
		$V_{CCI} = 2.3\text{ V}$ to 2.7 V	1.6	-	1.6	-	V
		$V_{CCI} = 3.0\text{ V}$ to 3.6 V	2	-	2	-	V
		DIR input					
		$V_{CC(A)} = 0.8\text{ V}$	$0.70V_{CC(A)}$	-	$0.70V_{CC(A)}$	-	V
		$V_{CC(A)} = 1.1\text{ V}$ to 1.95 V	$0.65V_{CC(A)}$	-	$0.65V_{CC(A)}$	-	V
$V_{CC(A)} = 2.3\text{ V}$ to 2.7 V	1.6	-	1.6	-	V		
$V_{CC(A)} = 3.0\text{ V}$ to 3.6 V	2	-	2	-	V		

Table 8. Static characteristics ...continued^{[1][2]}

At recommended operating conditions; voltages are referenced to GND (ground = 0 V).

Symbol	Parameter	Conditions	-40 °C to +85 °C		-40 °C to +125 °C		Unit
			Min	Max	Min	Max	
V _{IL}	LOW-level input voltage	data input					
		V _{CCI} = 0.8 V	-	0.30V _{CCI}	-	0.30V _{CCI}	V
		V _{CCI} = 1.1 V to 1.95 V	-	0.35V _{CCI}	-	0.35V _{CCI}	V
		V _{CCI} = 2.3 V to 2.7 V	-	0.7	-	0.7	V
		V _{CCI} = 3.0 V to 3.6 V	-	0.9	-	0.9	V
		DIR input					
		V _{CC(A)} = 0.8 V	-	0.30V _{CC(A)}	-	0.30V _{CC(A)}	V
		V _{CC(A)} = 1.1 V to 1.95 V	-	0.35V _{CC(A)}	-	0.35V _{CC(A)}	V
V _{OH}	HIGH-level output voltage	V _I = V _{IH} or V _{IL}					
		I _O = -100 μA; V _{CC(A)} = V _{CC(B)} = 0.8 V to 3.6 V	V _{CCO} - 0.1	-	V _{CCO} - 0.1	-	V
		I _O = -3 mA; V _{CC(A)} = V _{CC(B)} = 1.1 V	0.85	-	0.85	-	V
		I _O = -6 mA; V _{CC(A)} = V _{CC(B)} = 1.4 V	1.05	-	1.05	-	V
		I _O = -8 mA; V _{CC(A)} = V _{CC(B)} = 1.65 V	1.2	-	1.2	-	V
		I _O = -9 mA; V _{CC(A)} = V _{CC(B)} = 2.3 V	1.75	-	1.75	-	V
V _{OL}	LOW-level output voltage	V _I = V _{IH} or V _{IL}					
		I _O = 100 μA; V _{CC(A)} = V _{CC(B)} = 0.8 V to 3.6 V	-	0.1	-	0.1	V
		I _O = 3 mA; V _{CC(A)} = V _{CC(B)} = 1.1 V	-	0.25	-	0.25	V
		I _O = 6 mA; V _{CC(A)} = V _{CC(B)} = 1.4 V	-	0.35	-	0.35	V
		I _O = 8 mA; V _{CC(A)} = V _{CC(B)} = 1.65 V	-	0.45	-	0.45	V
		I _O = 9 mA; V _{CC(A)} = V _{CC(B)} = 2.3 V	-	0.55	-	0.55	V
I _I	input leakage current	I _O = 12 mA; V _{CC(A)} = V _{CC(B)} = 3.0 V	-	0.7	-	0.7	V
		DIR input; V _I = 0 V or 3.6 V; V _{CC(A)} = V _{CC(B)} = 0.8 V to 3.6 V	-	±1	-	±1.5	μA
I _{OZ}	OFF-state output current	A or B port; V _O = 0 V or V _{CCO} ; V _{CC(A)} = V _{CC(B)} = 3.6 V ^[3]	-	±5	-	±7.5	μA
I _{OFF}	power-off leakage current	A port; V _I or V _O = 0 V to 3.6 V; V _{CC(A)} = 0 V; V _{CC(B)} = 0.8 V to 3.6 V	-	±5	-	±35	μA
		B port; V _I or V _O = 0 V to 3.6 V; V _{CC(B)} = 0 V; V _{CC(A)} = 0.8 V to 3.6 V	-	±5	-	±35	μA

Table 8. Static characteristics ...continued [1][2]

At recommended operating conditions; voltages are referenced to GND (ground = 0 V).

Symbol	Parameter	Conditions	-40 °C to +85 °C		-40 °C to +125 °C		Unit
			Min	Max	Min	Max	
I _{CC}	supply current	A port; V _I = 0 V or V _{CCI} ; I _O = 0 A					
		V _{CC(A)} = 0.8 V to 3.6 V; V _{CC(B)} = 0.8 V to 3.6 V	-	8	-	12	μA
		V _{CC(A)} = 3.6 V; V _{CC(B)} = 0 V	-	8	-	12	μA
		V _{CC(A)} = 0 V; V _{CC(B)} = 3.6 V	-2	-	-8	-	μA
		B port; V _I = 0 V or V _{CCI} ; I _O = 0 A					
		V _{CC(A)} = 0.8 V to 3.6 V; V _{CC(B)} = 0.8 V to 3.6 V	-	8	-	12	μA
		V _{CC(A)} = 3.6 V; V _{CC(B)} = 0 V	-2	-	-8	-	μA
		V _{CC(A)} = 0 V; V _{CC(B)} = 3.6 V	-	8	-	12	μA
		A plus B port (I _{CC(A)} + I _{CC(B)}); I _O = 0 A; V _I = 0 V or V _{CCI} ; V _{CC(A)} = 0.8 V to 3.6 V; V _{CC(B)} = 0.8 V to 3.6 V	-	16	-	24	μA

[1] V_{CCO} is the supply voltage associated with the output port.[2] V_{CCI} is the supply voltage associated with the data input port.[3] For I/O ports, the parameter I_{OZ} includes the input leakage current.

11. Dynamic characteristics

Table 9. Typical dynamic characteristics at $V_{CC(A)} = 0.8\text{ V}$ and $T_{amb} = 25\text{ °C}$ [1]

Voltages are referenced to GND (ground = 0 V); for test circuit see [Figure 9](#); for wave forms see [Figure 7](#) and [Figure 8](#)

Symbol	Parameter	Conditions	$V_{CC(B)}$						Unit
			0.8 V	1.2 V	1.5 V	1.8 V	2.5 V	3.3 V	
t_{pd}	propagation delay	A to B	15.5	8.1	7.6	7.7	8.4	9.2	ns
		B to A	15.5	12.7	12.3	12.2	12.0	11.8	ns
t_{dis}	disable time	DIR to A	12.2	12.2	12.2	12.2	12.2	12.2	ns
		DIR to B	11.7	7.9	7.6	8.2	8.7	10.2	ns
t_{en}	enable time	DIR to A	27.2	20.6	19.9	20.4	20.7	22.0	ns
		DIR to B	27.7	20.3	19.8	19.9	20.6	21.4	ns

- [1] t_{pd} is the same as t_{PLH} and t_{PHL} ; t_{dis} is the same as t_{PLZ} and t_{PHZ} ; t_{en} is the same as t_{PZL} and t_{PZH} .
 t_{en} is a calculated value using the formula shown in [Section 13.4 "Enable times"](#)

Table 10. Typical dynamic characteristics at $V_{CC(B)} = 0.8\text{ V}$ and $T_{amb} = 25\text{ °C}$ [1]

Voltages are referenced to GND (ground = 0 V); for test circuit see [Figure 9](#); for wave forms see [Figure 7](#) and [Figure 8](#)

Symbol	Parameter	Conditions	$V_{CC(A)}$						Unit
			0.8 V	1.2 V	1.5 V	1.8 V	2.5 V	3.3 V	
t_{pd}	propagation delay	A to B	15.5	12.7	12.3	12.2	12.0	11.8	ns
		B to A	15.5	8.1	7.6	7.7	8.4	9.2	ns
t_{dis}	disable time	DIR to A	12.2	4.9	3.8	3.7	2.8	3.4	ns
		DIR to B	11.7	9.2	9.0	8.8	8.7	8.6	ns
t_{en}	enable time	DIR to A	27.2	17.3	16.6	16.5	17.1	17.8	ns
		DIR to B	27.7	17.6	16.1	15.9	14.8	15.2	ns

- [1] t_{pd} is the same as t_{PLH} and t_{PHL} ; t_{dis} is the same as t_{PLZ} and t_{PHZ} ; t_{en} is the same as t_{PZL} and t_{PZH} .
 t_{en} is a calculated value using the formula shown in [Section 13.4 "Enable times"](#)

Table 11. Typical power dissipation capacitance at $V_{CC(A)} = V_{CC(B)}$ and $T_{amb} = 25\text{ °C}$ [1][2]

Voltages are referenced to GND (ground = 0 V).

Symbol	Parameter	Conditions	$V_{CC(A)}$ and $V_{CC(B)}$						Unit
			0.8 V	1.2 V	1.5 V	1.8 V	2.5 V	3.3 V	
C_{PD}	power dissipation capacitance	A port: (direction A to B); B port: (direction B to A)	1	2	2	2	2	2	pF
		A port: (direction B to A); B port: (direction A to B)	9	11	11	12	14	17	pF

- [1] C_{PD} is used to determine the dynamic power dissipation (P_D in μW).

$$P_D = C_{PD} \times V_{CC}^2 \times f_i \times N + \sum(C_L \times V_{CC}^2 \times f_o) \text{ where:}$$

f_i = input frequency in MHz;

f_o = output frequency in MHz;

C_L = load capacitance in pF;

V_{CC} = supply voltage in V;

N = number of inputs switching;

$\sum(C_L \times V_{CC}^2 \times f_o)$ = sum of the outputs.

- [2] $f_i = 10\text{ MHz}$; $V_i = \text{GND to } V_{CC}$; $t_r = t_f = 1\text{ ns}$; $C_L = 0\text{ pF}$; $R_L = \infty\ \Omega$.

Table 12. Dynamic characteristics for temperature range –40 °C to +85 °C [1]

Voltages are referenced to GND (ground = 0 V); for test circuit see [Figure 9](#); for wave forms see [Figure 7](#) and [Figure 8](#).

Symbol	Parameter	Conditions	V _{CC(B)}										Unit
			1.2 V ± 0.1 V		1.5 V ± 0.1 V		1.8 V ± 0.15 V		2.5 V ± 0.2 V		3.3 V ± 0.3 V		
			Min	Max	Min	Max	Min	Max	Min	Max	Min	Max	
V_{CC(A)} = 1.1 V to 1.3 V													
t _{pd}	propagation delay	A to B	1.0	9.0	0.7	6.8	0.6	6.1	0.5	5.7	0.5	6.1	ns
		B to A	1.0	9.0	0.8	8.0	0.7	7.7	0.6	7.2	0.5	7.1	ns
t _{dis}	disable time	DIR to A	2.2	8.8	2.2	8.8	2.2	8.8	2.2	8.8	2.2	8.8	ns
		DIR to B	2.2	8.4	1.8	6.7	2.0	6.9	1.7	6.2	2.4	7.2	ns
t _{en}	enable time	DIR to A	-	17.4	-	14.7	-	14.6	-	13.4	-	14.3	ns
		DIR to B	-	17.8	-	15.6	-	14.9	-	14.5	-	14.9	ns
V_{CC(A)} = 1.4 V to 1.6 V													
t _{pd}	propagation delay	A to B	1.0	8.0	0.7	5.4	0.6	4.6	0.5	3.7	0.5	3.5	ns
		B to A	1.0	6.8	0.8	5.4	0.7	5.1	0.6	4.7	0.5	4.5	ns
t _{dis}	disable time	DIR to A	1.6	6.3	1.6	6.3	1.6	6.3	1.6	6.3	1.6	6.3	ns
		DIR to B	2.0	7.6	1.8	5.9	1.6	6.0	1.2	4.8	1.7	5.5	ns
t _{en}	enable time	DIR to A	-	14.4	-	11.3	-	11.1	-	9.5	-	10.0	ns
		DIR to B	-	14.3	-	11.7	-	10.9	-	10.0	-	9.8	ns
V_{CC(A)} = 1.65 V to 1.95 V													
t _{pd}	propagation delay	A to B	1.0	7.7	0.6	5.1	0.5	4.3	0.5	3.4	0.5	3.1	ns
		B to A	1.0	6.1	0.7	4.6	0.5	4.4	0.5	3.9	0.5	3.7	ns
t _{dis}	disable time	DIR to A	1.6	5.5	1.6	5.5	1.6	5.5	1.6	5.5	1.6	5.5	ns
		DIR to B	1.8	7.7	1.8	5.7	1.4	5.8	1.0	4.5	1.5	5.2	ns
t _{en}	enable time	DIR to A	-	13.8	-	10.3	-	10.2	-	8.4	-	8.9	ns
		DIR to B	-	13.2	-	10.6	-	9.8	-	8.9	-	8.6	ns
V_{CC(A)} = 2.3 V to 2.7 V													
t _{pd}	propagation delay	A to B	1.0	7.2	0.5	4.7	0.5	3.9	0.5	3.0	0.5	2.6	ns
		B to A	1.0	5.7	0.6	3.8	0.5	3.4	0.5	3.0	0.5	2.8	ns
t _{dis}	disable time	DIR to A	1.5	4.2	1.5	4.2	1.5	4.2	1.5	4.2	1.5	4.2	ns
		DIR to B	1.7	7.3	2.0	5.2	1.5	5.1	0.6	4.2	1.1	4.8	ns
t _{en}	enable time	DIR to A	-	13.0	-	9.0	-	8.5	-	7.2	-	7.6	ns
		DIR to B	-	11.4	-	8.9	-	8.1	-	7.2	-	6.8	ns
V_{CC(A)} = 3.0 V to 3.6 V													
t _{pd}	propagation delay	A to B	1.0	7.1	0.5	4.5	0.5	3.7	0.5	2.8	0.5	2.4	ns
		B to A	1.0	6.1	0.6	3.6	0.5	3.1	0.5	2.6	0.5	2.4	ns
t _{dis}	disable time	DIR to A	1.5	4.7	1.5	4.7	1.5	4.7	1.5	4.7	1.5	4.7	ns
		DIR to B	1.7	7.2	0.7	5.5	0.6	5.5	0.7	4.1	1.7	4.7	ns
t _{en}	enable time	DIR to A	-	13.3	-	9.1	-	8.6	-	6.7	-	7.1	ns
		DIR to B	-	11.8	-	9.2	-	8.4	-	7.5	-	7.1	ns

[1] t_{pd} is the same as t_{PLH} and t_{PHL}; t_{dis} is the same as t_{PLZ} and t_{PHZ}; t_{en} is the same as t_{PZL} and t_{PZH}.
t_{en} is a calculated value using the formula shown in [Section 13.4 "Enable times"](#)

Table 13. Dynamic characteristics for temperature range –40 °C to +125 °C [1]

Voltages are referenced to GND (ground = 0 V); for test circuit see [Figure 9](#); for wave forms see [Figure 7](#) and [Figure 8](#)

Symbol	Parameter	Conditions	V _{CC(B)}										Unit
			1.2 V ± 0.1 V		1.5 V ± 0.1 V		1.8 V ± 0.15 V		2.5 V ± 0.2 V		3.3 V ± 0.3 V		
			Min	Max	Min	Max	Min	Max	Min	Max	Min	Max	
V_{CC(A)} = 1.1 V to 1.3 V													
t _{pd}	propagation delay	A to B	1.0	9.9	0.7	7.5	0.6	6.8	0.5	6.3	0.5	6.8	ns
		B to A	1.0	9.9	0.8	8.8	0.7	8.5	0.6	8.0	0.5	7.9	ns
t _{dis}	disable time	DIR to A	2.2	9.7	2.2	9.7	2.2	9.7	2.2	9.7	2.2	9.7	ns
		DIR to B	2.2	9.2	1.8	7.4	2.0	7.6	1.7	6.9	2.4	8.0	ns
t _{en}	enable time	DIR to A	-	19.1	-	16.2	-	16.1	-	14.9	-	15.9	ns
		DIR to B	-	19.6	-	17.2	-	16.5	-	16.0	-	16.5	ns
V_{CC(A)} = 1.4 V to 1.6 V													
t _{pd}	propagation delay	A to B	1.0	8.8	0.7	6.0	0.6	5.1	0.5	4.1	0.5	3.9	ns
		B to A	1.0	7.5	0.8	6.0	0.7	5.7	0.6	5.2	0.5	5.0	ns
t _{dis}	disable time	DIR to A	1.6	7.0	1.6	7.0	1.6	7.0	1.6	7.0	1.6	7.0	ns
		DIR to B	2.0	8.3	1.8	6.5	1.6	6.6	1.2	5.3	1.7	6.1	ns
t _{en}	enable time	DIR to A	-	15.8	-	12.5	-	12.3	-	10.5	-	11.1	ns
		DIR to B	-	15.8	-	13.0	-	12.1	-	11.1	-	10.9	ns
V_{CC(A)} = 1.65 V to 1.95 V													
t _{pd}	propagation delay	A to B	1.0	8.5	0.6	5.7	0.5	4.8	0.5	3.8	0.5	3.5	ns
		B to A	1.0	6.8	0.7	5.1	0.5	4.9	0.5	4.3	0.5	4.1	ns
t _{dis}	disable time	DIR to A	1.6	6.1	1.6	6.1	1.6	6.1	1.6	6.1	1.6	6.1	ns
		DIR to B	1.8	8.5	1.8	6.3	1.4	6.4	1.0	5.0	1.5	5.8	ns
t _{en}	enable time	DIR to A	-	15.3	-	11.4	-	11.3	-	9.3	-	9.9	ns
		DIR to B	-	14.6	-	11.8	-	10.9	-	9.9	-	9.6	ns
V_{CC(A)} = 2.3 V to 2.7 V													
t _{pd}	propagation delay	A to B	1.0	8.0	0.5	5.2	0.5	4.3	0.5	3.3	0.5	2.9	ns
		B to A	1.0	6.3	0.6	4.2	0.5	3.8	0.5	3.3	0.5	3.1	ns
t _{dis}	disable time	DIR to A	1.5	4.7	1.5	4.7	1.5	4.7	1.5	4.7	1.5	4.7	ns
		DIR to B	1.7	8.0	2.0	5.8	1.5	5.7	0.6	4.7	1.1	5.3	ns
t _{en}	enable time	DIR to A	-	14.3	-	10.0	-	9.5	-	8.0	-	8.4	ns
		DIR to B	-	12.7	-	9.9	-	9.0	-	8.0	-	7.6	ns
V_{CC(A)} = 3.0 V to 3.6 V													
t _{pd}	propagation delay	A to B	1.0	7.9	0.5	5.0	0.5	4.1	0.5	3.1	0.5	2.7	ns
		B to A	1.0	6.8	0.6	4.0	0.5	3.5	0.5	2.9	0.5	2.7	ns
t _{dis}	disable time	DIR to A	1.5	5.2	1.5	5.2	1.5	5.2	1.5	5.2	1.5	5.2	ns
		DIR to B	1.7	7.9	0.7	6.1	0.6	6.1	0.7	4.6	1.7	5.2	ns
t _{en}	enable time	DIR to A	-	14.7	-	10.1	-	9.6	-	7.5	-	7.9	ns
		DIR to B	-	13.1	-	10.2	-	9.3	-	8.3	-	7.9	ns

[1] t_{pd} is the same as t_{PLH} and t_{PHL}; t_{dis} is the same as t_{PLZ} and t_{PHZ}; t_{en} is the same as t_{PZL} and t_{PZH}.
t_{en} is a calculated value using the formula shown in [Section 13.4 "Enable times"](#)

12. Waveforms

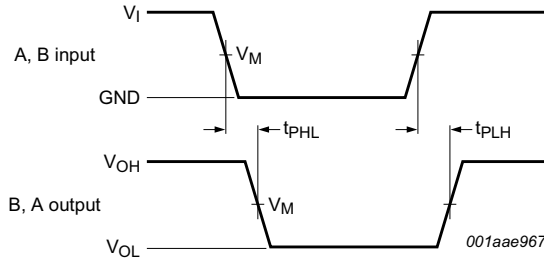

Measurement points are given in [Table 14](#).
 V_{OL} and V_{OH} are typical output voltage drops that occur with the output load.

Fig 7. The data input (A, B) to output (B, A) propagation delay times

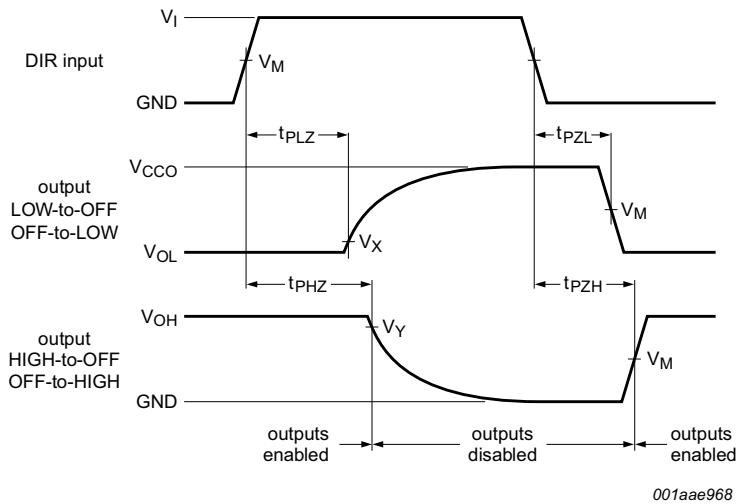

Measurement points are given in [Table 14](#).
 V_{OL} and V_{OH} are typical output voltage drops that occur with the output load.

Fig 8. Enable and disable times

Table 14. Measurement points

Supply voltage	Input ^[1]	Output ^[2]		
$V_{CC(A)}, V_{CC(B)}$	V_M	V_M	V_X	V_Y
1.1 V to 1.6 V	$0.5V_{CCI}$	$0.5V_{CCO}$	$V_{OL} + 0.1 V$	$V_{OH} - 0.1 V$
1.65 V to 2.7 V	$0.5V_{CCI}$	$0.5V_{CCO}$	$V_{OL} + 0.15 V$	$V_{OH} - 0.15 V$
3.0 V to 3.6 V	$0.5V_{CCI}$	$0.5V_{CCO}$	$V_{OL} + 0.3 V$	$V_{OH} - 0.3 V$

[1] V_{CCI} is the supply voltage associated with the data input port.

[2] V_{CCO} is the supply voltage associated with the output port.

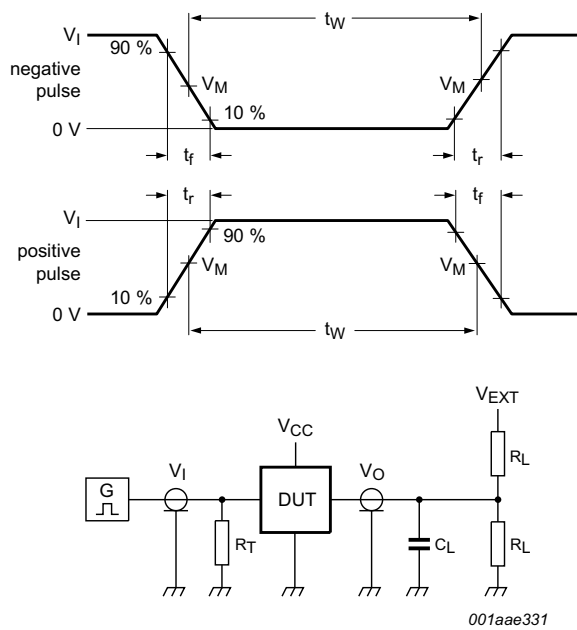

Test data is given in [Table 15](#).
 R_L = Load resistance.
 C_L = Load capacitance including jig and probe capacitance.
 R_T = Termination resistance.
 V_{EXT} = External voltage for measuring switching times.

Fig 9. Test circuit for measuring switching times

Table 15. Test data

Supply voltage	Input		Load		V_{EXT}		
	$V_{CC(I)}$ ^[1]	$\Delta t/\Delta V$ ^[2]	C_L	R_L	t_{PLH} , t_{PHL}	t_{PZH} , t_{PHZ}	t_{PZL} , t_{PLZ} ^[3]
1.1 V to 1.6 V	V_{CCI}	≤ 1.0 ns/V	15 pF	2 k Ω	open	GND	$2V_{CCO}$
1.65 V to 2.7 V	V_{CCI}	≤ 1.0 ns/V	15 pF	2 k Ω	open	GND	$2V_{CCO}$
3.0 V to 3.6 V	V_{CCI}	≤ 1.0 ns/V	15 pF	2 k Ω	open	GND	$2V_{CCO}$

- [1] V_{CCI} is the supply voltage associated with the data input port.
- [2] $dV/dt \geq 1.0$ V/ns
- [3] V_{CCO} is the supply voltage associated with the output port.

13. Application information

13.1 Unidirectional logic level-shifting application

The circuit given in [Figure 10](#) is an example of the 74AVC1T45 being used in an unidirectional logic level-shifting application.

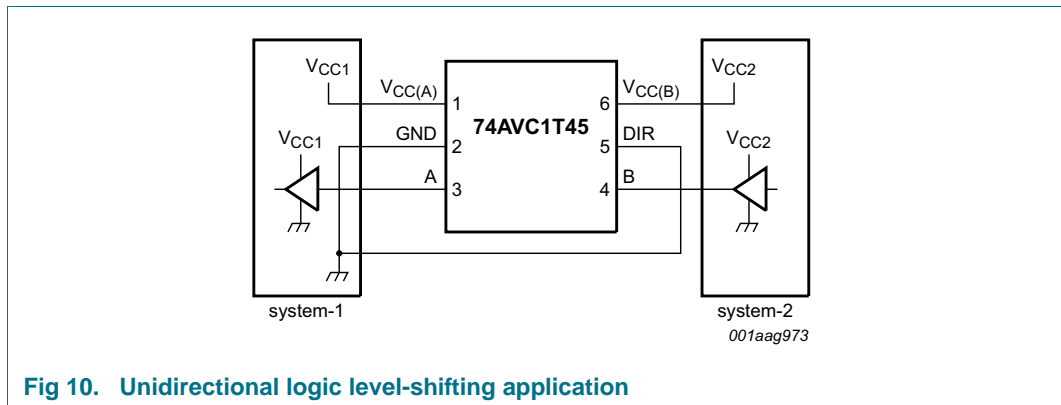

Fig 10. Unidirectional logic level-shifting application

Table 16. Description unidirectional logic level-shifting application

Pin	Name	Function	Description
1	$V_{CC(A)}$	V_{CC1}	supply voltage of system-1 (0.8 V to 3.6 V)
2	GND	GND	device GND
3	A	OUT	output level depends on V_{CC1} voltage
4	B	IN	input threshold value depends on V_{CC2} voltage
5	DIR	DIR	the GND (LOW level) determines B port to A port direction
6	$V_{CC(B)}$	V_{CC2}	supply voltage of system-2 (0.8 V to 3.6 V)

13.2 Bidirectional logic level-shifting application

Figure 11 shows the 74AVC1T45 being used in a bidirectional logic level-shifting application. Since the device does not have an output enable pin, the system designer should take precautions to avoid bus contention between system-1 and system-2 when changing directions.

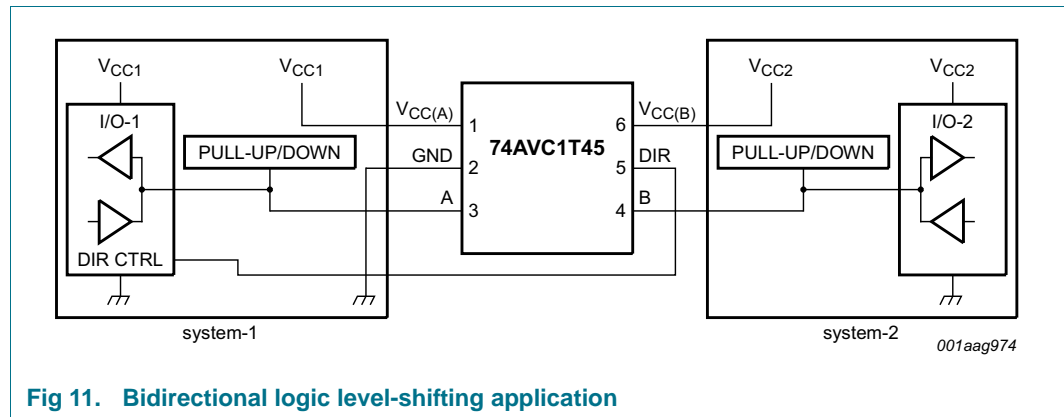

Fig 11. Bidirectional logic level-shifting application

Table 17 gives a sequence that will illustrate data transmission from system-1 to system-2 and then from system-2 to system-1.

Table 17. Description bidirectional logic level-shifting application^[1]

State	DIR CTRL	I/O-1	I/O-2	Description
1	H	output	input	system-1 data to system-2
2	H	Z	Z	system-2 is getting ready to send data to system-1. I/O-1 and I/O-2 are disabled. The bus-line state depends on bus hold.
3	L	Z	Z	DIR bit is set LOW. I/O-1 and I/O-2 still are disabled. The bus-line state depends on bus hold.
4	L	input	output	system-2 data to system-1

[1] H = HIGH voltage level;
 L = LOW voltage level;
 Z = high-impedance OFF-state.

13.3 Power-up considerations

The device is designed such that no special power-up sequence is required other than GND being applied first.

Table 18. Typical total supply current ($I_{CC(A)} + I_{CC(B)}$)

$V_{CC(A)}$	$V_{CC(B)}$							Unit
	0 V	0.8 V	1.2 V	1.5 V	1.8 V	2.5 V	3.3 V	
0 V	0	0.1	0.1	0.1	0.1	0.1	0.1	μA
0.8 V	0.1	0.1	0.1	0.1	0.1	0.7	2.3	μA
1.2 V	0.1	0.1	0.1	0.1	0.1	0.3	1.4	μA
1.5 V	0.1	0.1	0.1	0.1	0.1	0.1	0.9	μA
1.8 V	0.1	0.1	0.1	0.1	0.1	0.1	0.5	μA
2.5 V	0.1	0.7	0.3	0.1	0.1	0.1	0.1	μA
3.3 V	0.1	2.3	1.4	0.9	0.5	0.1	0.1	μA

13.4 Enable times

Calculate the enable times for the 74AVC1T45 using the following formulas:

- $t_{en}(\text{DIR to A}) = t_{dis}(\text{DIR to B}) + t_{pd}(\text{B to A})$
- $t_{en}(\text{DIR to B}) = t_{dis}(\text{DIR to A}) + t_{pd}(\text{A to B})$

In a bidirectional application, these enable times provide the maximum delay from the time the DIR bit is switched until an output is expected. For example, if the 74AVC1T45 initially is transmitting from A to B, then the DIR bit is switched, the B port of the device must be disabled before presenting it with an input. After the B port has been disabled, an input signal applied to it appears on the corresponding A port after the specified propagation delay.

14. Package outline

Plastic surface-mounted package; 6 leads

SOT363

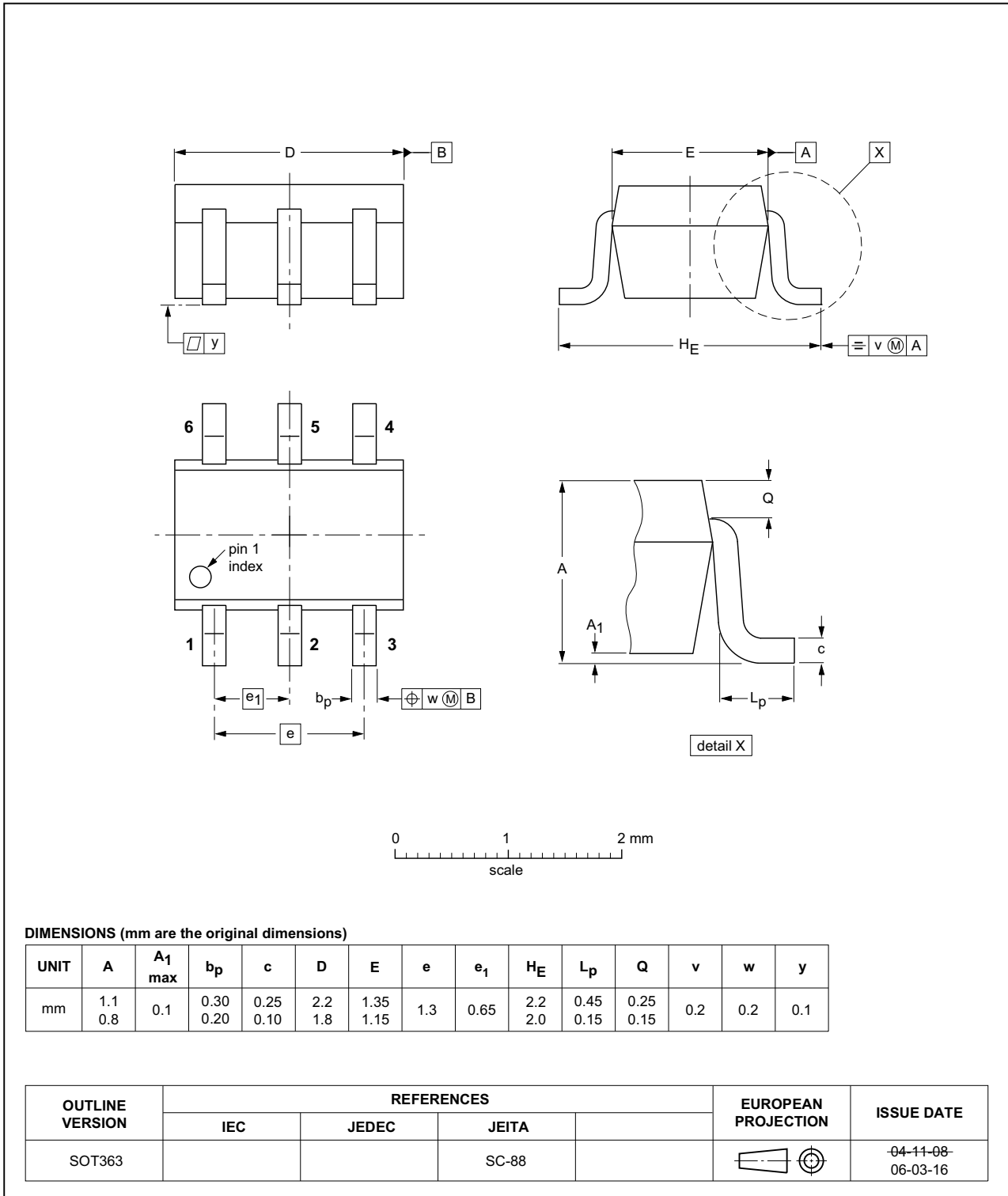

Fig 12. Package outline SOT363 (SC-88)

XSON6: plastic extremely thin small outline package; no leads; 6 terminals; body 1 x 1.45 x 0.5 mm

SOT886

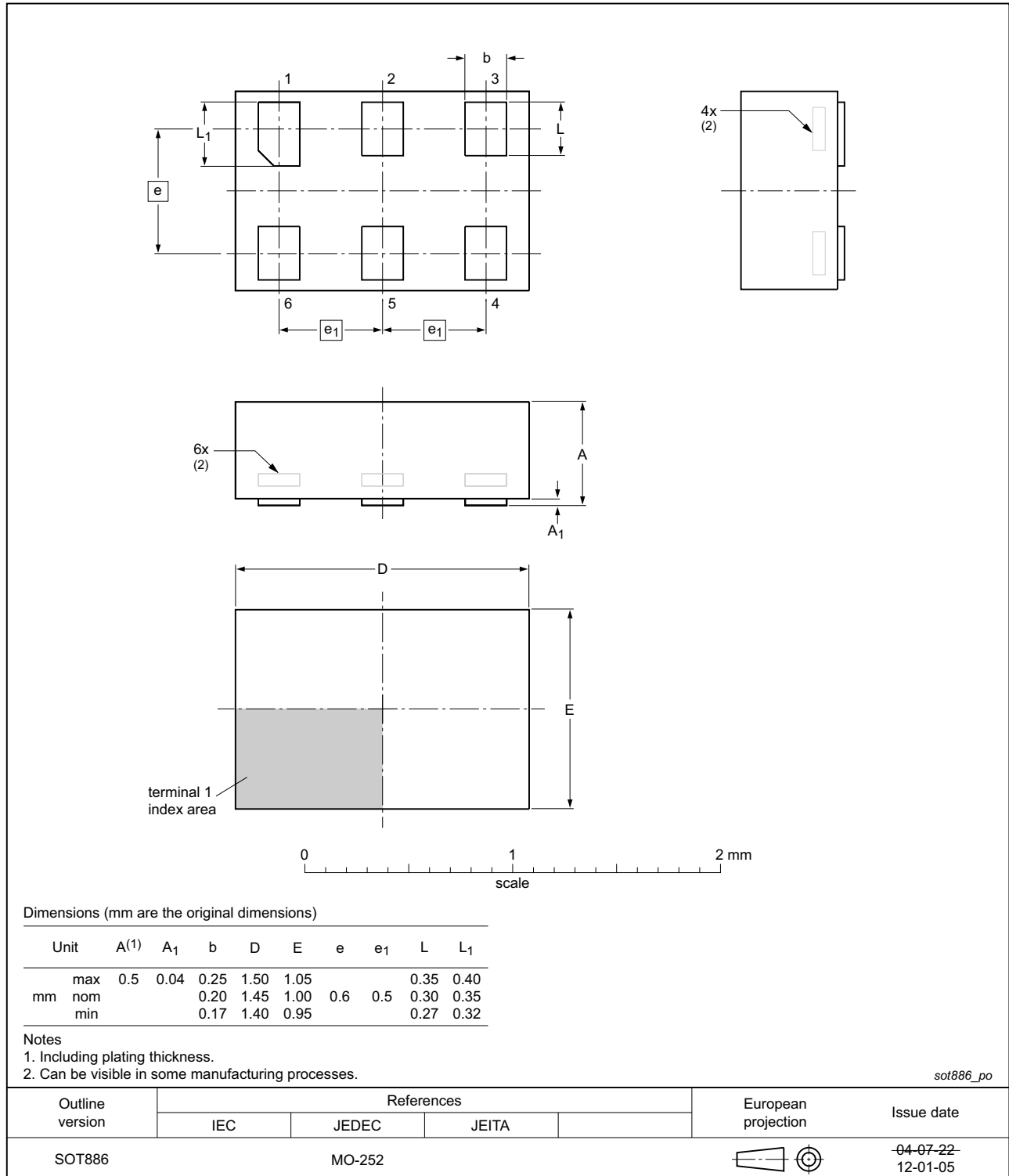

Fig 13. Package outline SOT886 (XSON6)

**XSON6: extremely thin small outline package; no leads;
6 terminals; body 0.9 x 1.0 x 0.35 mm**

SOT1115



Fig 14. Package outline SOT1115 (XSON6)

XSON6: extremely thin small outline package; no leads;
6 terminals; body 1.0 x 1.0 x 0.35 mm

SOT1202



Fig 15. Package outline SOT1202 (XSON6)

X2SON6: plastic thermal enhanced extremely thin small outline package; no leads; 6 terminals; body 1.0 x 0.8 x 0.35 mm

SOT1255

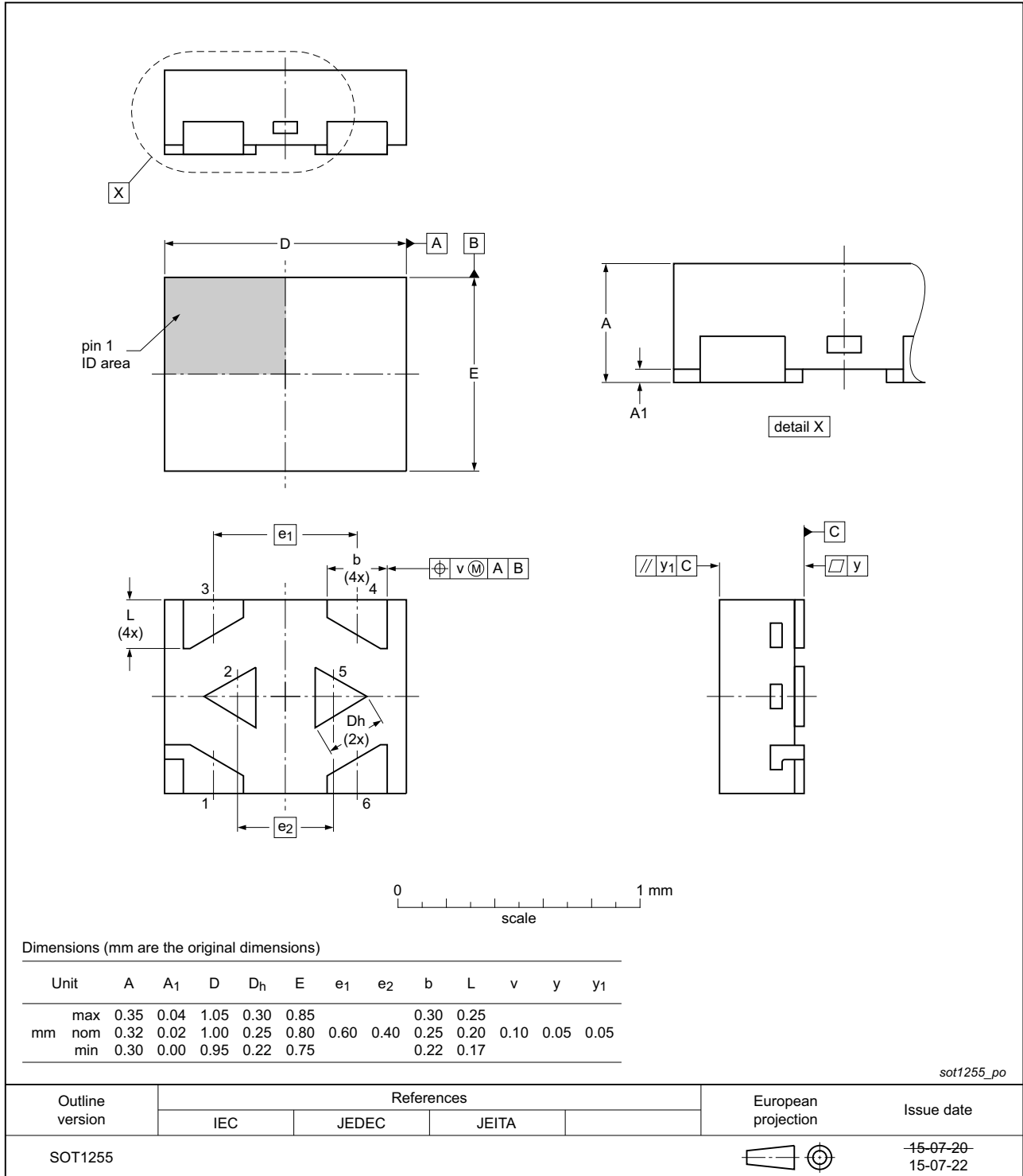

Fig 16. Package outline SOT1255 (X2SON6)

15. Abbreviations

Table 19. Abbreviations

Acronym	Description
CDM	Charged Device Model
CMOS	Complementary Metal Oxide Semiconductor
DUT	Device Under Test
ESD	ElectroStatic Discharge
HBM	Human Body Model
MM	Machine Model

16. Revision history

Table 20. Revision history

Document ID	Release date	Data sheet status	Change notice	Supersedes
74AVC1T45 v.6	20160420	Product data sheet	-	74AVC1T45 v.5
Modifications:	<ul style="list-style-type: none"> Added type number 74AVC1T45GX(SOT1255/X2SON6 package). 			
74AVC1T45 v.5	20160106	Product data sheet	-	74AVC1T45 v.4
Modifications:	<ul style="list-style-type: none"> Table 16: Labels for pins 4 and 5 corrected. 			
74AVC1T45 v.4	20120622	Product data sheet	-	74AVC1T45 v.3
Modifications:	<ul style="list-style-type: none"> Package outline drawing of SOT886 (Figure 13) modified. 			
74AVC1T45 v.3	20111021	Product data sheet	-	74AVC1T45 v.2
Modifications:	<ul style="list-style-type: none"> Added type number 74AVC1T45GN (SOT1115/XSON6 package). Added type number 74AVC1T45GS (SOT1202/XSON6 package). 			
74AVC1T45 v.2	20090505	Product data sheet	-	74AVC1T45 v.1
74AVC1T45 v.1	20080118	Product data sheet	-	-

17. Legal information

17.1 Data sheet status

Document status ^{[1][2]}	Product status ^[3]	Definition
Objective [short] data sheet	Development	This document contains data from the objective specification for product development.
Preliminary [short] data sheet	Qualification	This document contains data from the preliminary specification.
Product [short] data sheet	Production	This document contains the product specification.

[1] Please consult the most recently issued document before initiating or completing a design.

[2] The term 'short data sheet' is explained in section "Definitions".

[3] The product status of device(s) described in this document may have changed since this document was published and may differ in case of multiple devices. The latest product status information is available on the Internet at URL <http://www.nexperia.com>.

17.2 Definitions

Draft — The document is a draft version only. The content is still under internal review and subject to formal approval, which may result in modifications or additions. Nexperia does not give any representations or warranties as to the accuracy or completeness of information included herein and shall have no liability for the consequences of use of such information.

Short data sheet — A short data sheet is an extract from a full data sheet with the same product type number(s) and title. A short data sheet is intended for quick reference only and should not be relied upon to contain detailed and full information. For detailed and full information see the relevant full data sheet, which is available on request via the local Nexperia sales office. In case of any inconsistency or conflict with the short data sheet, the full data sheet shall prevail.

Product specification — The information and data provided in a Product data sheet shall define the specification of the product as agreed between Nexperia and its customer, unless Nexperia and customer have explicitly agreed otherwise in writing. In no event however, shall an agreement be valid in which the Nexperia product is deemed to offer functions and qualities beyond those described in the Product data sheet.

17.3 Disclaimers

Limited warranty and liability — Information in this document is believed to be accurate and reliable. However, Nexperia does not give any representations or warranties, expressed or implied, as to the accuracy or completeness of such information and shall have no liability for the consequences of use of such information. Nexperia takes no responsibility for the content in this document if provided by an information source outside of Nexperia.

In no event shall Nexperia be liable for any indirect, incidental, punitive, special or consequential damages (including - without limitation - lost profits, lost savings, business interruption, costs related to the removal or replacement of any products or rework charges) whether or not such damages are based on tort (including negligence), warranty, breach of contract or any other legal theory.

Notwithstanding any damages that customer might incur for any reason whatsoever, Nexperia's aggregate and cumulative liability towards customer for the products described herein shall be limited in accordance with the *Terms and conditions of commercial sale* of Nexperia.

Right to make changes — Nexperia reserves the right to make changes to information published in this document, including without limitation specifications and product descriptions, at any time and without notice. This document supersedes and replaces all information supplied prior to the publication hereof.

Suitability for use — Nexperia products are not designed, authorized or warranted to be suitable for use in life support, life-critical or safety-critical systems or equipment, nor in applications where failure or malfunction of a Nexperia product can reasonably be expected to result in personal injury, death or severe property or environmental damage. Nexperia and its suppliers accept no liability for inclusion and/or use of Nexperia products in such equipment or applications and therefore such inclusion and/or use is at the customer's own risk.

Applications — Applications that are described herein for any of these products are for illustrative purposes only. Nexperia makes no representation or warranty that such applications will be suitable for the specified use without further testing or modification.

Customers are responsible for the design and operation of their applications and products using Nexperia products, and Nexperia accepts no liability for any assistance with applications or customer product design. It is customer's sole responsibility to determine whether the Nexperia product is suitable and fit for the customer's applications and products planned, as well as for the planned application and use of customer's third party customer(s). Customers should provide appropriate design and operating safeguards to minimize the risks associated with their applications and products.

Nexperia does not accept any liability related to any default, damage, costs or problem which is based on any weakness or default in the customer's applications or products, or the application or use by customer's third party customer(s). Customer is responsible for doing all necessary testing for the customer's applications and products using Nexperia products in order to avoid a default of the applications and the products or of the application or use by customer's third party customer(s). Nexperia does not accept any liability in this respect.

Limiting values — Stress above one or more limiting values (as defined in the Absolute Maximum Ratings System of IEC 60134) will cause permanent damage to the device. Limiting values are stress ratings only and (proper) operation of the device at these or any other conditions above those given in the Recommended operating conditions section (if present) or the Characteristics sections of this document is not warranted. Constant or repeated exposure to limiting values will permanently and irreversibly affect the quality and reliability of the device.

Terms and conditions of commercial sale — Nexperia products are sold subject to the general terms and conditions of commercial sale, as published at <http://www.nexperia.com/profile/terms>, unless otherwise agreed in a valid written individual agreement. In case an individual agreement is concluded only the terms and conditions of the respective agreement shall apply. Nexperia hereby expressly objects to applying the customer's general terms and conditions with regard to the purchase of Nexperia products by customer.

No offer to sell or license — Nothing in this document may be interpreted or construed as an offer to sell products that is open for acceptance or the grant, conveyance or implication of any license under any copyrights, patents or other industrial or intellectual property rights.

Export control — This document as well as the item(s) described herein may be subject to export control regulations. Export might require a prior authorization from competent authorities.

Non-automotive qualified products — Unless this data sheet expressly states that this specific Nexperia product is automotive qualified, the product is not suitable for automotive use. It is neither qualified nor tested in accordance with automotive testing or application requirements. Nexperia accepts no liability for inclusion and/or use of non-automotive qualified products in automotive equipment or applications.

In the event that customer uses the product for design-in and use in automotive applications to automotive specifications and standards, customer (a) shall use the product without Nexperia's warranty of the product for such automotive applications, use and specifications, and (b) whenever customer uses the product for automotive applications beyond

Nexperia's specifications such use shall be solely at customer's own risk, and (c) customer fully indemnifies Nexperia for any liability, damages or failed product claims resulting from customer design and use of the product for automotive applications beyond Nexperia's standard warranty and Nexperia's product specifications.

Translations — A non-English (translated) version of a document is for reference only. The English version shall prevail in case of any discrepancy between the translated and English versions.

17.4 Trademarks

Notice: All referenced brands, product names, service names and trademarks are the property of their respective owners.

18. Contact information

For more information, please visit: <http://www.nexperia.com>

For sales office addresses, please send an email to: salesaddresses@nexperia.com

19. Contents

1	General description	1
2	Features and benefits	1
3	Ordering information	2
4	Marking	2
5	Functional diagram	3
6	Pinning information	3
6.1	Pinning	3
6.2	Pin description	4
7	Functional description	4
8	Limiting values	5
9	Recommended operating conditions	5
10	Static characteristics	6
11	Dynamic characteristics	9
12	Waveforms	12
13	Application information	14
13.1	Unidirectional logic level-shifting application .	14
13.2	Bidirectional logic level-shifting application. .	15
13.3	Power-up considerations	16
13.4	Enable times	16
14	Package outline	17
15	Abbreviations	22
16	Revision history	22
17	Legal information	23
17.1	Data sheet status	23
17.2	Definitions	23
17.3	Disclaimers	23
17.4	Trademarks	24
18	Contact information	24
19	Contents	25

X-ON Electronics

Largest Supplier of Electrical and Electronic Components

Click to view similar products for [Translation - Voltage Levels](#) category:

Click to view products by [NXP](#) manufacturer:

Other Similar products are found below :

[NLJVHC1GT08DFT2G](#) [NLSX4373DMR2G](#) [NLSX5012MUTAG](#) [HV583GA-G](#) [NLSX0102FCT1G](#) [NLSX0102FCT2G](#)
[NLSX4302EBMUTCG](#) [NLVSX4373DR2G](#) [PCA9306FMUTAG](#) [SY10H351JZ](#) [MC100EPT622MNG](#) [MAX9374AEKA+T](#) [MAX3378EETD+](#)
[MAX34405BEZT+](#) [NLSX3014MUTAG](#) [NVT4556BUKZ](#) [NLSV4T244EMUTAG](#) [NLSX5011MUTCG](#) [NLV9306USG](#)
[NLVSX4014MUTAG](#) [MAX34405BEZT+T](#) [NLSV4T3144MUTAG](#) [NSV12200LT1G](#) [NLVSX4373MUTAG](#) [NB3U23CMNTAG](#)
[MAX3371ELT+T](#) [MAX3008EUP+T](#) [NLVPCA9306AMUTCG](#) [NLSX3013BFCT1G](#) [MAX9378EUA+T](#) [NLV7WBD3125USG](#)
[NLV14504BDTG](#) [NLSX3012DMR2G](#) [NLSX5012DR2G](#) [MAX3391EEUD+T](#) [MAX3379EETD+](#) [PI4ULS3V4857GEAEX](#)
[MAX3391EEBC+T](#) [MAX14842ATE+T](#) [74AVCH1T45FZ4-7](#) [CLVC16T245MDGGREP](#) [HEF4104BT](#) [TC74LCX16245\(EL,F\)](#)
[MC10H124FNG](#) [CAVCB164245MDGGREP](#) [7WBD383USG](#) [NVT2001GM,115](#) [CLVC8T245MRHLTEP](#) [74LVC1G175GS,132](#)
[FXLA104UM12X](#)