

DO NOT SCALE FROM THIS PRINT

QSS-XXX-XX-XXX-D-XXX

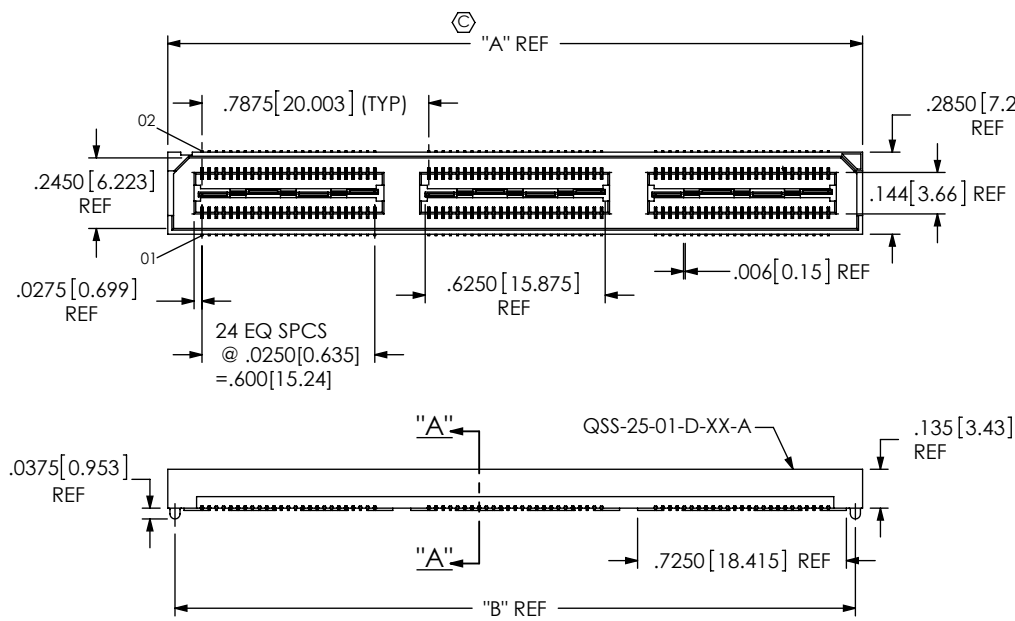

- No OF POSITIONS
 -025, -050, -075,
 *-100, *-125
- *SEE NOTES 11 & 14
- LEAD STYLE
 -01: .1430 [3.632]
- PLATING SPECIFICATION
 (SEE NOTES 8 & 11)
 -F: 3μ" FLASH SELECTIVE GOLD IN CONTACT AREA, MATTE TIN ON TAIL (USE C-126-21-F & T-1G2-01-F) (SEE NOTE 8)
 -L: 10μ" LIGHT SELECTIVE GOLD, IN CONTACT AREA, MATTE TIN ON TAIL (USE C-126-21-L & T-1G2-01-L)
 -H: 30μ" HEAVY GOLD IN CONTACT AREA, 3μ" GOLD ON TAIL (USE C-126-21-H & T-1G2-01-G)
 -C: 50μ" HEAVY GOLD IN CONTACT AREA, MATTE TIN ON TAIL (USE C-126-21-C & T-1G2-01-L)
 -STL: 30μ" HEAVY SELECTIVE GOLD IN CONTACT AREA, TIN LEAD ON TAIL (USE C-126-21-STL & T-1G2-01-STL)
 -FTL: 3μ" FLASH SELECTIVE GOLD IN CONTACT AREA, TIN LEAD ON TAIL (USE C-126-21-FTL & T-1G2-01-FTL)
- OPTION
 -A: ALIGNMENT PINS (USE QSS-25-XX-D-XX-A) (NOT AVAILABLE WITH -LC)
 -LC: LOCKING CLIPS (SEE NOTE 12) (USE LC-08-TM-01, SEE FIG 2, SHT 2) (NOT AVAILABLE WITH -A)
 -K: POLYIMIDE FILM PAD (USE K-DOT-.325-.450-.005) (SEE FIG 3, SHT 2)
 -TR: TAPE & REEL (75 POS MAX) (50 POS MAX FOR -GP)
 -GP: GUIDE POSTS (USE QSS-25-01-D-XX-X-GP) (SEE FIG 4, SHT 3) (NOT AVAILABLE WITH -LS2)
 -LS2: LOCKING SCREW (USE QSS-25-01-D-XX-LS2) (SEE FIG 5, SHT 3) (NOT AVAILABLE WITH -GP) (FOR MATING WITH QTS-...-RA-...LS2)
- ROW SPECIFICATION
 -D: DOUBLE (USE QSS-25-XX-D-XX)
- No OF BANKS

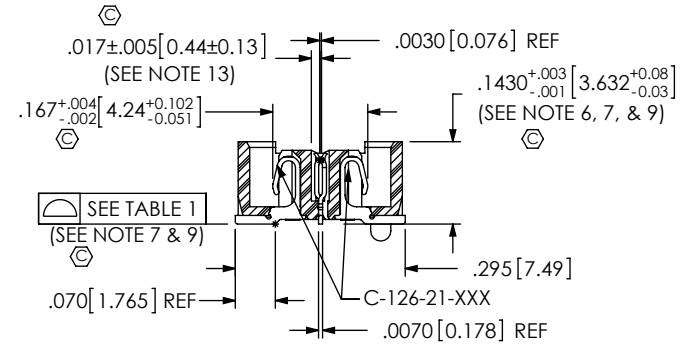
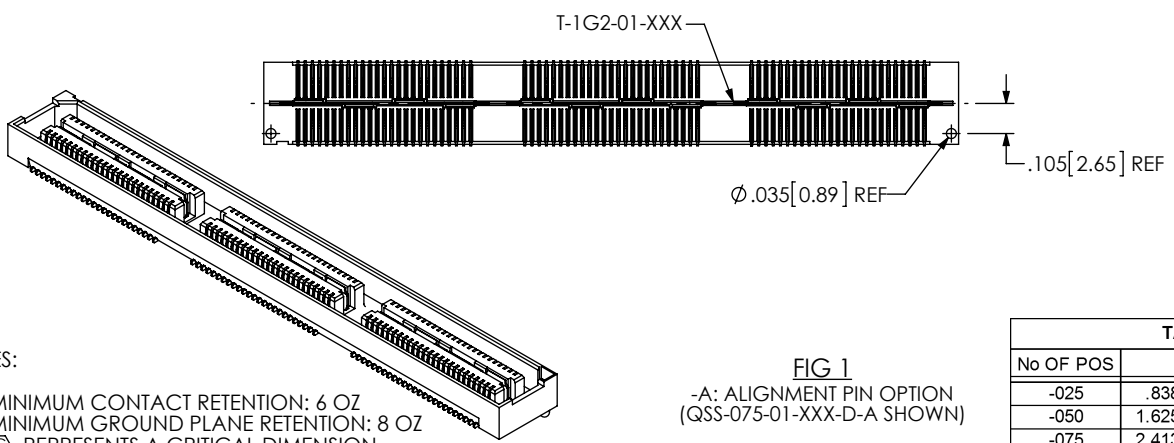

- NOTES:
1. MINIMUM CONTACT RETENTION: 6 OZ
 2. MINIMUM GROUND PLANE RETENTION: 8 OZ
 3. Ⓢ REPRESENTS A CRITICAL DIMENSION.
 4. PARTS ARE MOLD TO POSITION.
 5. NOTE DELETED.
 6. MAXIMUM VARIANCE OF .002 [0.05].
 7. DIMENSION APPLIES TO CONTACTS AND GROUND PLANES, INDEPENDENT OF GROUND PLANES AND CONTACTS RESPECTIVELY.
 8. -L PLATING CAN BE SUBSTITUTED FOR -F PLATING.
 9. GROUND PLANE PRESS HEIGHT MUST BE .003 [0.08] LESS THAN THE MAX HEIGHT OR .001 [0.03] GREATER THAN THE MINIMUM HEIGHT OF THE TERMINALS.
 10. NOTE DELETED.
 11. FOR -100 AND -125 POSITIONS USE C-269-11-X, DO NOT SUB C-126-01-X.
 12. DUE TO THE HIGH AMOUNT OF INSERTION FORCE NEEDED, THE -LC OPTION IS NOT COMPATIBLE WITH AUTO PLACEMENT. SAMTEC RECOMMENDS MANUAL PLACEMENT FOR ALL ASSEMBLIES WITH THE -LC OPTION.
 13. CHECK ONCE PER BANK ALTERNATING SIDES FOR MULTIPLE BANK PARTS.
 14. AVAILABLE FOR EXISTING CUSTOMERS ONLY.

FIG 1
 -A: ALIGNMENT PIN OPTION (QSS-075-01-XXX-D-A SHOWN)

TABLE 2

No OF POS	"A"	"B"
-025	.838 [21.27]	.788 [20.00]
-050	1.625 [41.28]	1.575 [40.01]
-075	2.413 [61.28]	2.363 [60.01]
*-100	3.200 [81.28]	3.150 [80.01]
*-125	3.988 [101.28]	3.938 [100.01]

* = SEE NOTES 11 & 14

TABLE 1

No OF POSITIONS	COPLANARITY (INCLUDING GND PLANE)
-025 THRU -050	.0040 [102]
-075, *-100, *-125	.0060 [152]

* = SEE NOTES 11 & 14

<p>UNLESS OTHERWISE SPECIFIED, DIMENSIONS ARE IN INCHES[MM]</p> <p>TOLERANCES ARE:</p> <p>DECIMALS ANGLES</p> <p>.XX: ±.01 [3]</p> <p>.XXX: ±.005 [13]</p> <p>.XXXX: ±.0020 [051]</p>	<p>PROPRIETARY NOTE</p> <p>THIS DOCUMENT CONTAINS CONFIDENTIAL AND PROPRIETARY INFORMATION AND ALL DESIGN, MANUFACTURING, REPRODUCTION, USE, PATENT RIGHTS AND SALES RIGHTS ARE EXPRESSLY RESERVED BY SAMTEC, INC. THIS DOCUMENT SHALL NOT BE DISCLOSED, IN WHOLE OR PART, TO ANY UNAUTHORIZED PERSON OR ENTITY NOR REPRODUCED, TRANSFERRED OR INCORPORATED IN ANY OTHER PROJECT IN ANY MANNER WITHOUT THE EXPRESS WRITTEN CONSENT OF SAMTEC, INC.</p>	<p>520 PARK EAST BLVD, NEW ALBANY, IN 47150 PHONE: 812-944-6733 FAX: 812-948-5047 e-Mail: info@SAMTEC.com code 55322</p>

F:\DWG\MISC\MKTG\QSS-XXX-XX-XXX-D-XXX-MKT.SLDDRW

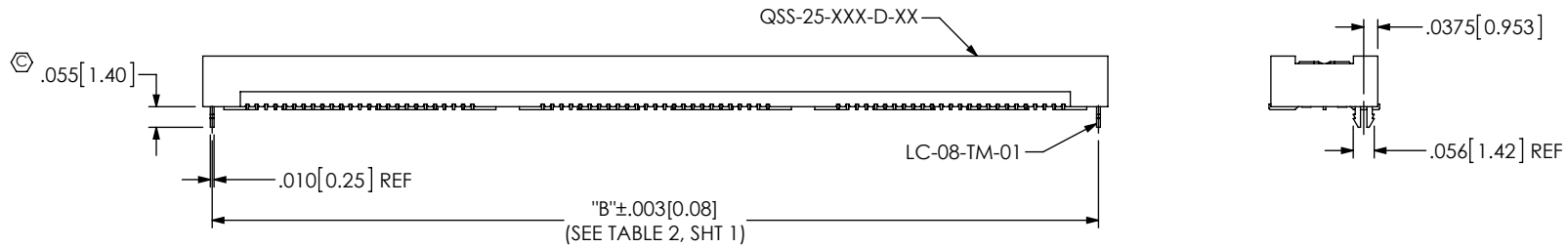

FIG 2
 -LC: LOCKING CLIP OPTION
 (QSS-075-01-XXX-D-LC SHOWN)
 (DIFFERENT AS SHOWN, OTHERWISE SAME AS FIG 1)

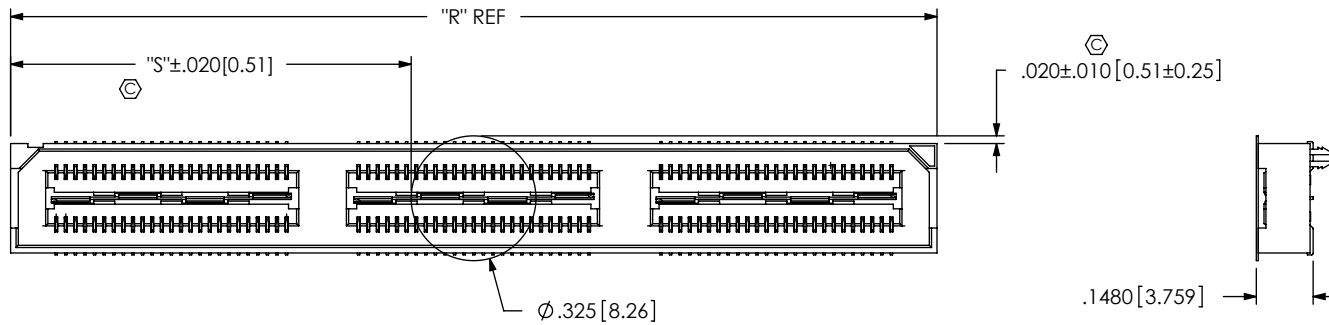



FIG 3
 -K: POLYIMIDE FILM PAD
 (USE K-DOT-.325-.450-.005)

No OF POS	"R"			"S"		
	-LC, -A	-GP	-LS2	-LC, -A	-GP	-LS2
-025	.838 [21.27]	1.217 [30.90]	1.338 [33.97]	.256 [6.51]	.446 [11.32]	.506 [12.86]
-050	1.625 [41.28]	2.004 [50.90]	2.125 [53.98]	.650 [16.51]	.840 [21.32]	.900 [22.86]
-075	2.413 [61.28]	2.792 [70.90]	2.913 [73.98]	1.044 [26.51]	1.233 [31.32]	1.294 [32.86]
*-100	3.200 [81.28]	3.579 [90.91]	3.700 [93.98]	1.438 [36.51]	1.627 [41.33]	1.688 [42.86]
*-125	3.988 [101.28]	4.367 [110.91]	4.488 [113.98]	1.831 [46.51]	2.021 [51.33]	2.081 [52.86]

* = SEE NOTES 11 & 14

<p>• PROPRIETARY NOTE</p> <p>THIS DOCUMENT CONTAINS CONFIDENTIAL AND PROPRIETARY INFORMATION AND ALL DESIGN, MANUFACTURING, REPRODUCTION, USE, PATENT RIGHTS AND SALES RIGHTS ARE EXPRESSLY RESERVED BY SAMTEC, INC. THIS DOCUMENT SHALL NOT BE DISCLOSED, IN WHOLE OR PART, TO ANY UNAUTHORIZED PERSON OR ENTITY NOR REPRODUCED, TRANSFERRED OR INCORPORATED IN ANY OTHER PROJECT IN ANY MANNER WITHOUT THE EXPRESS WRITTEN CONSENT OF SAMTEC, INC.</p>	 <p>520 PARK EAST BLVD, NEW ALBANY, IN 47150 PHONE: 812-944-6733 FAX: 812-948-5047 e-Mail info@SAMTEC.com code 55322</p>		
	DO NOT SCALE DRAWING SHEET SCALE: 2:1	DESCRIPTION: .635mm DOUBLE ROW HS SOCKET ASSEMBLY DWG. NO. QSS-XXX-XX-XXX-D-XXX	
		BY: DEAN P 6/28/1999	SHEET 2 OF 3

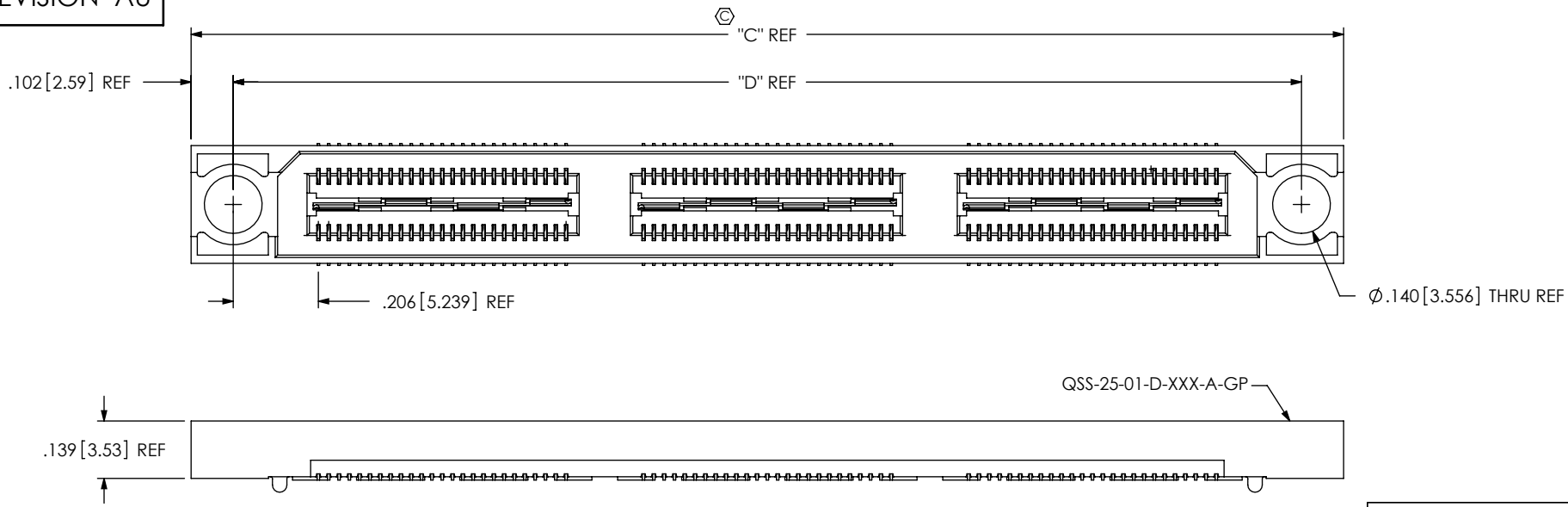

FIG 4
 -GP: GUIDE POST OPTION
 (QSS-075-01-XXX-D-GP SHOWN)
 (DIFFERENT AS SHOWN, OTHERWISE SAME AS FIG 1)
 (50 POS MAX FOR TAPE & REEL OFFERING)

TABLE 4

POS	"C"	"D"
-025	1.217 [30.90]	1.013 [25.72]
-050	2.004 [50.90]	1.800 [45.72]
-075	2.792 [70.90]	2.588 [65.72]
*-100	3.579 [90.91]	3.375 [85.73]
*-125	4.367 [110.91]	4.163 [105.73]

* = SEE NOTES 11 & 14

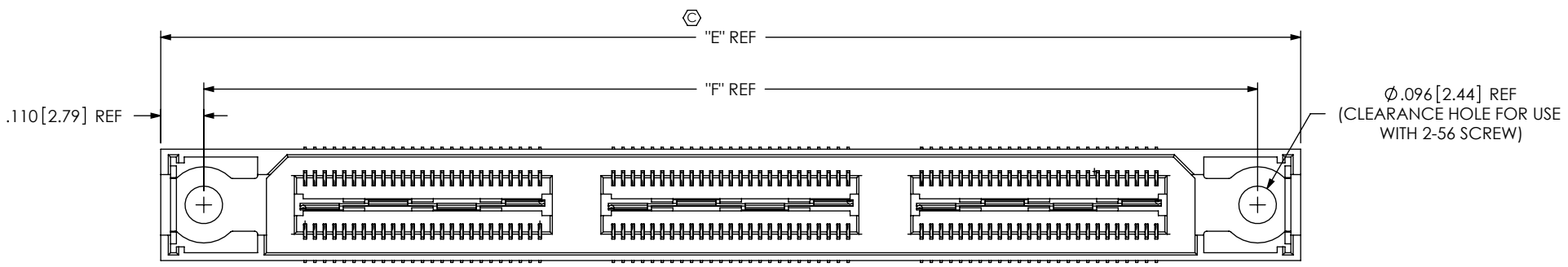

FIG 5
 -LS2: LOCKING SCREW OPTION
 (QSS-075-01-XXX-D-LS2 SHOWN)
 (DIFFERENT AS SHOWN, OTHERWISE SAME AS FIG 1)
 (NOT AVAILABLE WITH -GP OPTION)

TABLE 5

POS	"E"	"F"
-025	1.338 [33.97]	1.118 [28.38]
-050	2.125 [53.98]	1.905 [48.39]
-075	2.913 [73.98]	2.693 [68.39]
*-100	3.700 [93.98]	3.480 [88.39]
*-125	4.488 [113.98]	4.268 [108.39]

* = SEE NOTES 11 & 14

PROPRIETARY NOTE
 THIS DOCUMENT CONTAINS CONFIDENTIAL AND PROPRIETARY INFORMATION AND ALL DESIGN, MANUFACTURING, REPRODUCTION, USE, PATENT RIGHTS AND SALES RIGHTS ARE EXPRESSLY RESERVED BY SAMTEC, INC. THIS DOCUMENT SHALL NOT BE DISCLOSED, IN WHOLE OR PART, TO ANY UNAUTHORIZED PERSON OR ENTITY NOR REPRODUCED, TRANSFERRED OR INCORPORATED IN ANY OTHER PROJECT IN ANY MANNER WITHOUT THE EXPRESS WRITTEN CONSENT OF SAMTEC, INC.



520 PARK EAST BLVD, NEW ALBANY, IN 47150
 PHONE: 812-944-6733 FAX: 812-948-5047
 e-Mail info@SAMTEC.com code 55322

DO NOT SCALE DRAWING
 SHEET SCALE: 2.5:1

DESCRIPTION:
 .635mm DOUBLE ROW HS SOCKET ASSEMBLY

DWG. NO. **QSS-XXX-XX-XXX-D-XXX**

BY: DEAN P 6/28/1999 SHEET 3 OF 3

X-ON Electronics

Largest Supplier of Electrical and Electronic Components

Click to view similar products for [Board to Board & Mezzanine Connectors](#) category:

Click to view products by [Samtec](#) manufacturer:

Other Similar products are found below :

[10135583-642402LF](#) [89885-310LF](#) [589158040000018](#) [6-1393048-0](#) [68683-613](#) [MDF7-12DP-2.54DSA](#) [MDF7-18P-2.54DSA\(01\)](#) [MDF7-20DP-2.54DSA](#) [MDF7-26D-2.54DSA\(55\)](#) [MDF7-3P-2.54DSA\(01\)](#) [MDF7B-3P-2.54DSA\(55\)](#) [MDF7C-11P-2.54DSA\(55\)](#) [MDF7C-18P-2.54DSA\(55\)](#) [MDF7C-5P-2.54DSA\(01\)](#) [MDF7P-5P-2.54DSA\(55\)](#) [75234-0516](#) [FCN-230C068-11](#) [FCN-268F012-G/BD](#) [FCN-268F036-G/BD](#) [FCN-268M012-G/0D](#) [FCN-268M024-G/1D](#) [FCN-360C008-C](#) [FCN-360C040-C](#) [FCN-723J004/1](#) [MIS-048-01-F-D-DP-K](#) [832-10-034-10-001000](#) [93696-325LF](#) [11828-1FA](#) [AXK630345P](#) [18097-0013](#) [ICA-328STT](#) [2007042-2](#) [304400-2](#) [FCN-214Q030-G/0](#) [FCN-215Q040-G/0](#) [FCN-230C068-ESA](#) [FCN-234P048-G/0](#) [FCN-235D050-G/C](#) [FCN-360A3](#) [FCN-360C040-B](#) [210-93-314-41-105000](#) [2-22603-0](#) [379-064-521-202](#) [MDF7-12P-2.54DSA\(01\)](#) [MDF7-16P-2.54DS\(56\)](#) [MDF7-40DP-2.54DSA\(55\)](#) [MDF7-8P-2.54DSA\(55\)](#) [MDF7B-16P-2.54DSA\(55\)](#) [AXG720047](#) [5031084030](#)