

11.90	13.54	504622-7010	o	---	70
10.85	12.49	504622-6410	o	---	64
10.15	11.79	504622-6010	---	---	60
9.80	11.44	504622-5810	---	---	58
9.10	10.74	504622-5410	---	---	54
8.40	10.04	504622-5010	o	---	50
8.05	9.69	504622-4810	---	---	48
7.00	8.64	504622-4210	---	---	42
6.65	8.29	504622-4010	o	---	40
6.30	7.94	504622-3810	---	---	38
5.60	7.24	504622-3410	o	---	34
4.90	6.54	504622-3010	o	---	30
3.85	5.49	504622-2410	o	---	24
3.15	4.79	504622-2010	o	---	20
2.80	4.44	504622-1810	---	---	18
2.45	4.09	504622-1610	---	---	16
1.75	3.39	504622-1210	---	---	12
1.40	3.04	504622-1010	o	---	10
0.70	2.34	504622-0610	---	---	6

- NOTES
- MATERIAL
 WAFER : LIQUID CRYSTAL POLYMER UL94V-0(COLOR : BLACK)
 PIN : COPPER ALLOY
 FITTING NAIL : COPPER ALLOY
 - PLATING
 TERMINAL
 GOLD
 UNDER PLATING : NICKEL
 *DIVIDE INTO PARTS THE GOLD PLATING OF THE CONTACT AND THE TAIL PART BY THE NICKEL PLATING.
 FITTING NAIL
 GOLD
 UNDER PLATING : NICKEL
- △ APPLY FOR (CIRCUIT/2)-EVEN.
 4. MATE WITH : 504618-***10
 5. TAIL AND FITTING NAIL COPLANARITY TO BE 0.08MAXIMUM.
 △ PROHIBITED AREA OF PATTERN WIRING AND SOLDER.
 (FOR EACH AREA, THE WIRING THAT TOUCHES ON THE SOLDER CAN BE ATTACHED, THEN COVERED WITH A FILM TO KEEP SOLDER OUT.)
 7. ELV and RoHS COMPLIANT.
 8. ELECTRIC SPEC OF FITTING NAIL IS NOT GUARANTEED WHEN MATED.

B	A	EMBOSSED TAPE PACKAGE	HIGH VOL. TOOL	LOW VOL. TOOL	CIRCUIT
		ORDER NO.	SAMPLE PREPARATION o : TOOLED △ : WORK IN PROCESS --- : TOOLING TO BE CONFIRMED		

CONNECTOR SERIES No. : 504622-***09

REVISED EC NO: J2015-0816 DRWN:MYOSHIDA 2014/12/16 CHKD:RTAKEUCHI 2014/12/16 APPR:KMORIKAWA 2014/12/17	GENERAL TOLERANCES (UNLESS SPECIFIED)		DIMENSION STYLE MM ONLY	SCALE 20:1	DESIGN UNITS METRIC	THIRD ANGLE PROJECTION
	10 UNDER	±0.2	DRAWN BY HON001	DATE 2014/02/24	TITLE 0.35 BB CONN. H=0.6 SSB6 PLUG ASSY	
	10 OVER 30 UNDER	±0.25	CHECKED BY RTAKEUCHI	DATE 2014/02/24		
	30 OVER	±0.3	APPROVED BY KMORIKAWA	DATE 2014/04/17		
ANGULAR ±1 °	DRAFT WHERE APPLICABLE MUST REMAIN WITHIN DIMENSIONS	SEE CHART	MATERIAL NO.	DOCUMENT NO. SD-504622-001	SHEET NO. 1 OF 2	
			SIZE A3	THIS DRAWING CONTAINS INFORMATION THAT IS PROPRIETARY TO MOLEX INCORPORATED AND SHOULD NOT BE USED WITHOUT WRITTEN PERMISSION		

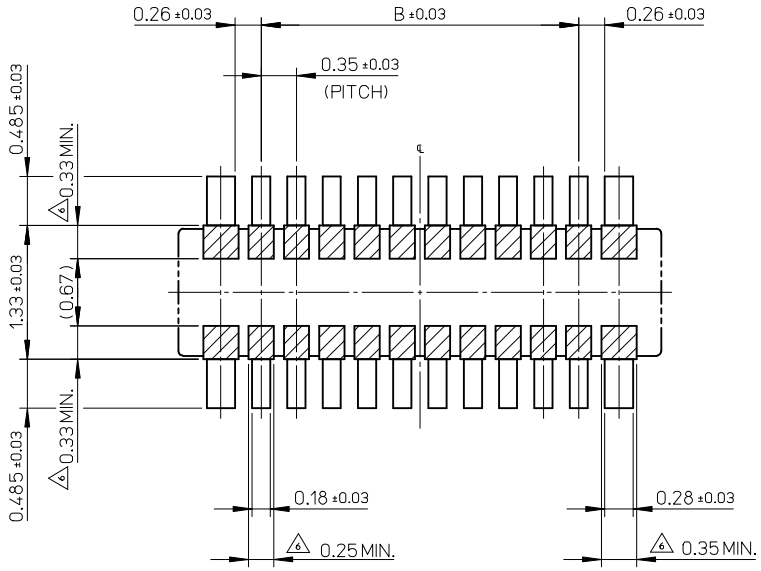

RECOMMENDED P.W.BOARD PATTERN LAYOUT(REFERENCE)

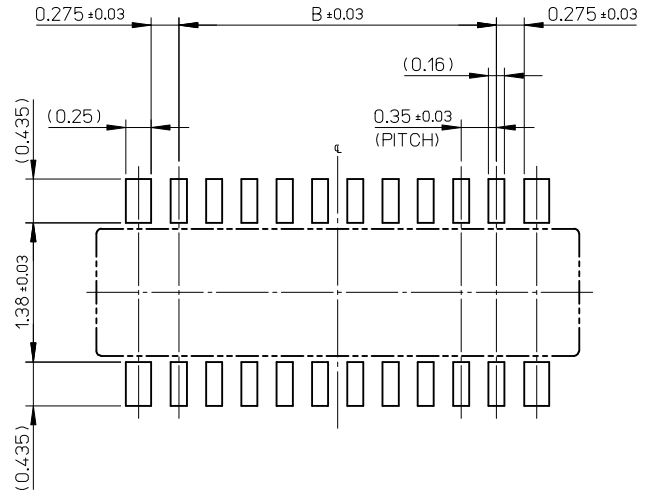

RECOMMENDED METAL MASK LAYOUT(REFERENCE)

RECOMMENDED THICKNESS OF METAL MASK : t=0.08mm
 RECOMMENDED OPEN APERTURE RATIO OF METAL MASK : 80%

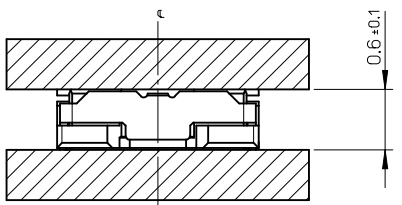

MATED CONDITION

REVISED EC NO: J2015-0816 DRWN:MYOSHIDA 2014/12/16 CHKD:RTAKEUCHI 2014/12/16 APPR:KMORIKAWA 2014/12/17	GENERAL TOLERANCES (UNLESS SPECIFIED)		DIMENSION STYLE MM ONLY		SCALE 20:1	DESIGN UNITS METRIC	THIRD ANGLE PROJECTION
	10 UNDER	± 0.2	DRAWN BY HON001	DATE 2014/02/24	TITLE 0.35 BB CONN. H=0.6 SSB6 PLUG ASSY		
	10 OVER 30 UNDER	± 0.25	CHECKED BY RTAKEUCHI	DATE 2014/02/24			
	30 OVER	± 0.3	APPROVED BY KMORIKAWA	DATE 2014/04/17			
	ANGULAR ± 1 °	MATERIAL NO. SEE SHEET 1		DOCUMENT NO. SD-504622-001		SHEET NO. 2 OF 2	
	DRAFT WHERE APPLICABLE MUST REMAIN WITHIN DIMENSIONS	THIS DRAWING CONTAINS INFORMATION THAT IS PROPRIETARY TO MOLEX INCORPORATED AND SHOULD NOT BE USED WITHOUT WRITTEN PERMISSION					

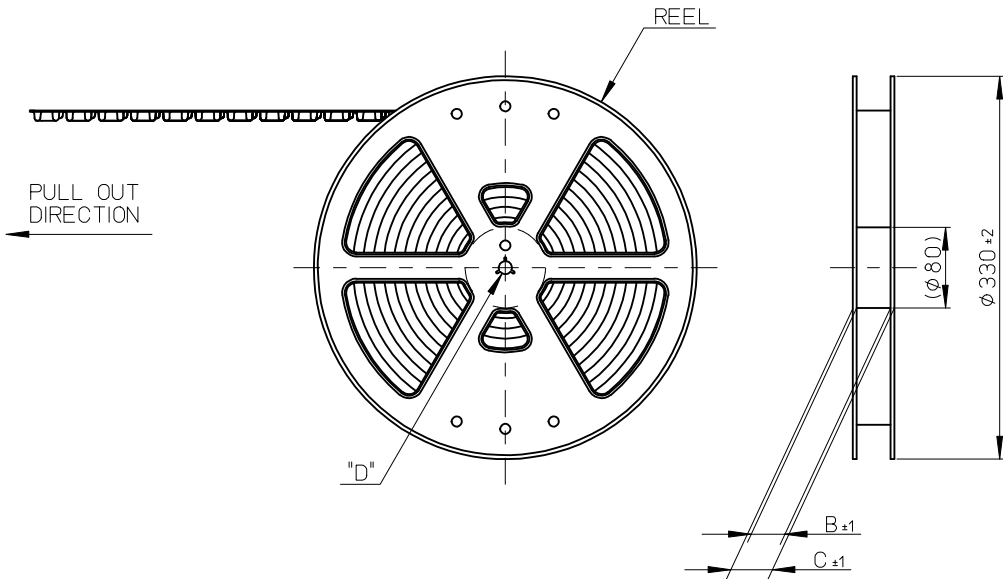

NOTES

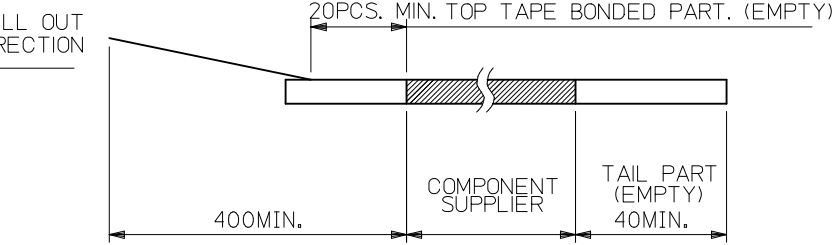
- RE DETAILED DIMENSION, SEE PRODUCT DRAWING.
- NUMBER OF CONNECTORS : 3000PCS/REEL
- LEAD TAPE LENGTH

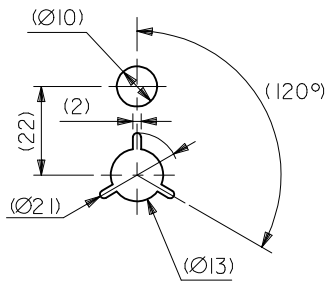
- TOP TAPE PEEL FORCE IS DEFINED BY IEC60286-3.
- MATERIAL
 CARRIER TAPE : POLYSTYRENE
 TOP TAPE : PET , OTHER
 REEL : POLYSTYRENE (PS) <RECYCLE MATERIAL CONTAINED>
- ELV AND RoHS COMPLIANT

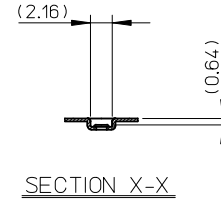
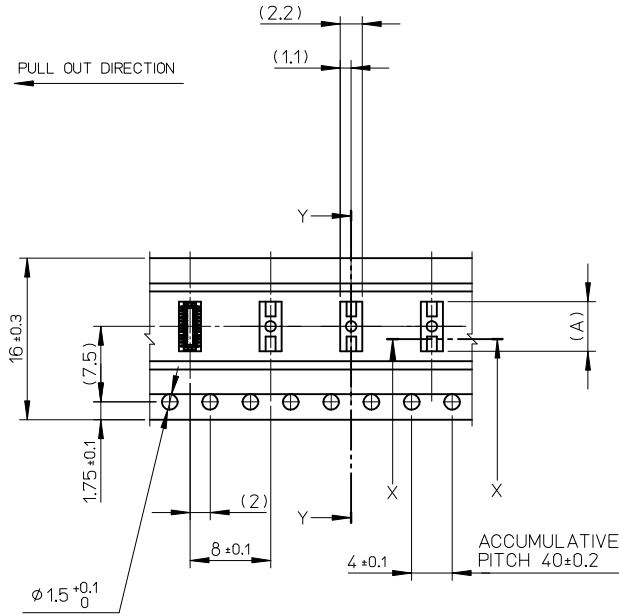
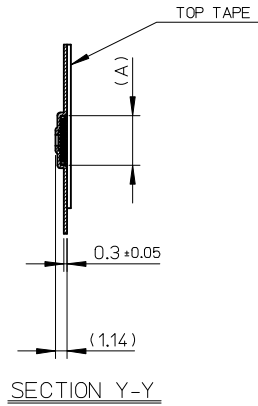

DETAIL "D"

REVISED EC NO: J2015-0816 DRWN:MYOSHIDA 2014/12/16 CHKD:RTAKEUCHI 2014/12/16 APPR:KMORIKAWA 2014/12/17	GENERAL TOLERANCES (UNLESS SPECIFIED)		DIMENSION STYLE	SCALE	MODEL NO.	504622-**10
			MM ONLY	1:5	DESIGN UNITS	METRIC
	10 UNDER ± 0.2 10 OVER 30 UNDER ± 0.25 30 OVER ± 0.3 ANGULAR ± 1 ° DRAFT WHERE APPLICABLE MUST REMAIN WITHIN DIMENSIONS		DRAWN BY HON001 DATE 2014/02/24 CHECKED BY RTAKEUCHI DATE 2014/02/24 APPROVED BY KMORIKAWA DATE 2014/04/17 MATERIAL NO. SEE CHART	TITLE	0.35 BB CONN. H=0.6 SSB6 PLUG ASSY EMBSTP PKG molex	
			DOCUMENT NO.		SD-504622-002	



16	21.4	17.4	6.68	504622-3010	○	---	30	
			5.63	504622-2410	○	---	24	
			4.93	504622-2010	○	---	20	
			4.58	504622-1810	---	---	18	
			4.23	504622-1610	---	---	16	
			3.53	504622-1210	---	---	12	
			3.18	504622-1010	○	---	10	
2.48	504622-0610	---	---	6				
キャリアテープ幅 CARRIER TAPE WIDTH		C	B	(A)	EMBOSSED TAPE PACKAGE	HIGH VOL. TOOL	LOW VOL. TOOL	CIRCUIT
ORDER NO.				SAMPLE PREPARATION ○ : TOOLED △ : WORK IN PROCESS --- : TOOLING TO BE CONFIRMED				

REVISED EC NO: J2015-0816 DRWN: MYOSHIDA 2014/12/16 CHKD: RTAKEUCHI 2014/12/16 APPR: KMORIKAWA 2014/12/17	GENERAL TOLERANCES (UNLESS SPECIFIED)		DIMENSION STYLE MM ONLY		SCALE 2:1	DESIGN UNITS METRIC	THIRD ANGLE PROJECTION	
	10 UNDER	± 0.2	DRAWN BY HON001	DATE 2014/02/24	TITLE 0.35 BB CONN. H=0.6 SSB6 PLUG ASSY EMBSTP PKG			
	10 OVER 30 UNDER	± 0.25	CHECKED BY RTAKEUCHI	DATE 2014/02/24				
	30 OVER	± 0.3	APPROVED BY KMORIKAWA	DATE 2014/04/17				
ANGULAR ± 1 °		DRAFT WHERE APPLICABLE MUST REMAIN WITHIN DIMENSIONS		MATERIAL NO. SEE CHART		DOCUMENT NO. SD-504622-002	SHEET NO. 2 OF 3	
THIS DRAWING CONTAINS INFORMATION THAT IS PROPRIETARY TO MOLEX INCORPORATED AND SHOULD NOT BE USED WITHOUT WRITTEN PERMISSION								

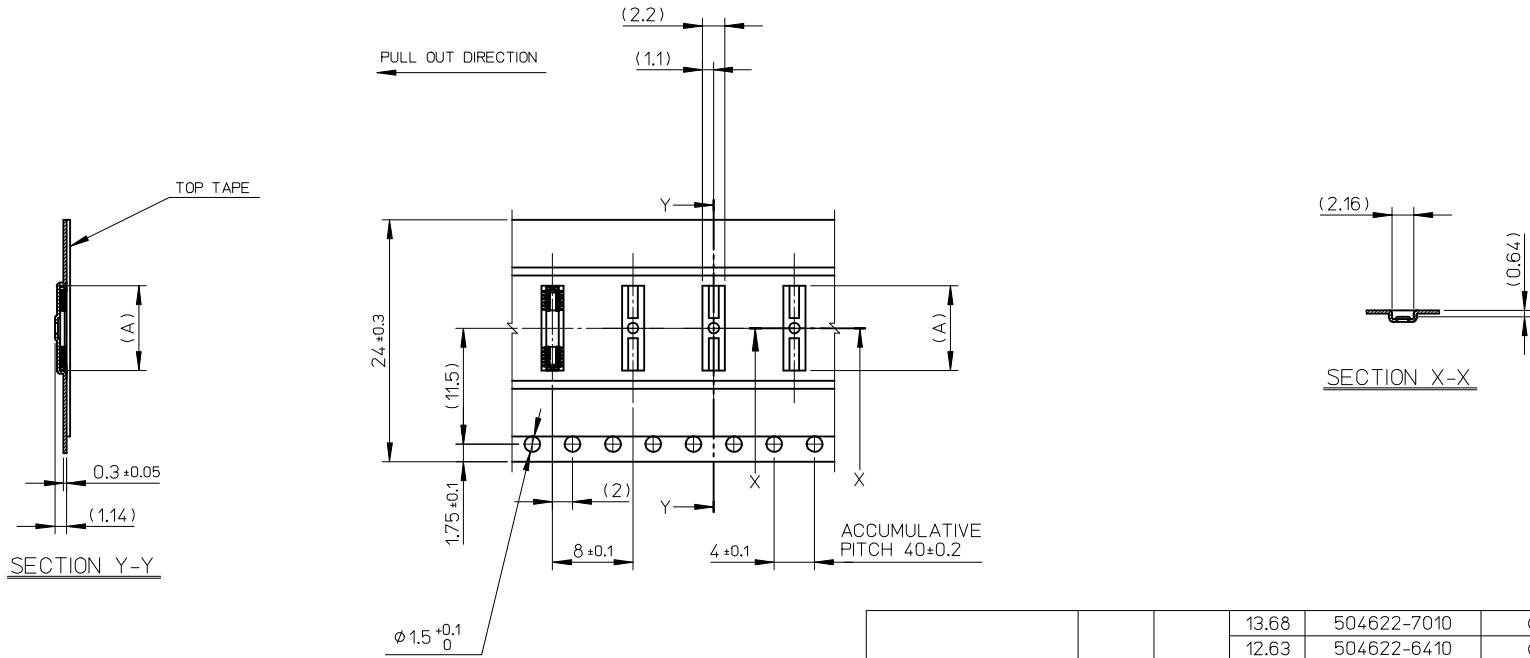

24	29.4	25.4	13.68	504622-7010	o	---	70		
			12.63	504622-6410	o	---	64		
			11.93	504622-6010	---	---	60		
			11.58	504622-5810	---	---	58		
			10.88	504622-5410	---	---	54		
			10.18	504622-5010	o	---	50		
			9.83	504622-4810	---	---	48		
			8.78	504622-4210	---	---	42		
			8.43	504622-4010	o	---	40		
			8.08	504622-3810	---	---	38		
7.38	504622-3410	o	---	34					
キャリアテープ幅 CARRIER TAPE WIDTH			C	B	(A)	EMBOSSED TAPE PACKAGE	HIGH VOL. TOOL	LOW VOL. TOOL	CIRCUIT
			ORDER NO.		SAMPLE PREPARATION o : TOOLED △ : WORK IN PROCESS --- : TOOLING TO BE CONFIRMED				

REVISED EC NO: J2015-0816 DRWN: MYOSHIDA 2014/12/16 CHKD: RTAKEUCHI 2014/12/16 APPR: KMORIKAWA 2014/12/17	GENERAL TOLERANCES (UNLESS SPECIFIED)		DIMENSION STYLE MM ONLY		SCALE 2:1	DESIGN UNITS METRIC	THIRD ANGLE PROJECTION	
	10 UNDER	±0.2	DRAWN BY HON001	DATE 2014/02/24	TITLE 0.35 BB CONN. H=0.6 SSB6 PLUG ASSY EMBSTP PKG			
	10 OVER 30 UNDER	±0.25	CHECKED BY RTAKEUCHI	DATE 2014/02/24				
	30 OVER	±0.3	APPROVED BY KMORIKAWA	DATE 2014/04/17				
	ANGULAR ±1°		DRAFT WHERE APPLICABLE MUST REMAIN WITHIN DIMENSIONS		MATERIAL NO. SEE CHART		DOCUMENT NO. SD-504622-002	SHEET NO. 3 OF 3

X-ON Electronics

Largest Supplier of Electrical and Electronic Components

Click to view similar products for [Board to Board & Mezzanine Connectors](#) category:

Click to view products by [Molex](#) manufacturer:

Other Similar products are found below :

[10135583-642402LF](#) [89885-310LF](#) [589158040000018](#) [6-1393048-0](#) [68683-613](#) [MDF7-12DP-2.54DSA](#) [MDF7-18P-2.54DSA\(01\)](#) [MDF7-20DP-2.54DSA](#) [MDF7-26D-2.54DSA\(55\)](#) [MDF7-3P-2.54DSA\(01\)](#) [MDF7B-3P-2.54DSA\(55\)](#) [MDF7C-11P-2.54DSA\(55\)](#) [MDF7C-18P-2.54DSA\(55\)](#) [MDF7C-5P-2.54DSA\(01\)](#) [MDF7P-5P-2.54DSA\(55\)](#) [75234-0516](#) [FCN-230C068-11](#) [FCN-268F012-G/BD](#) [FCN-268F036-G/BD](#) [FCN-268M012-G/0D](#) [FCN-268M024-G/1D](#) [FCN-360C008-C](#) [FCN-360C040-C](#) [FCN-723J004/1](#) [MIS-048-01-F-D-DP-K](#) [832-10-034-10-001000](#) [93696-325LF](#) [11828-1FA](#) [AXK630345P](#) [18097-0013](#) [ICA-328STT](#) [2007042-2](#) [304400-2](#) [FCN-214Q030-G/0](#) [FCN-215Q040-G/0](#) [FCN-230C068-ESA](#) [FCN-234P048-G/0](#) [FCN-235D050-G/C](#) [FCN-360A3](#) [FCN-360C040-B](#) [210-93-314-41-105000](#) [2-22603-0](#) [379-064-521-202](#) [MDF7-12P-2.54DSA\(01\)](#) [MDF7-16P-2.54DS\(56\)](#) [MDF7-40DP-2.54DSA\(55\)](#) [MDF7-8P-2.54DSA\(55\)](#) [MDF7B-16P-2.54DSA\(55\)](#) [AXG720047](#) [5031084030](#)