

3M™ FOUR-WALL HEADER, 3000 SERIES

.100" X .100" LATCH/EJECTOR, STRAIGHT AND RIGHT ANGLE

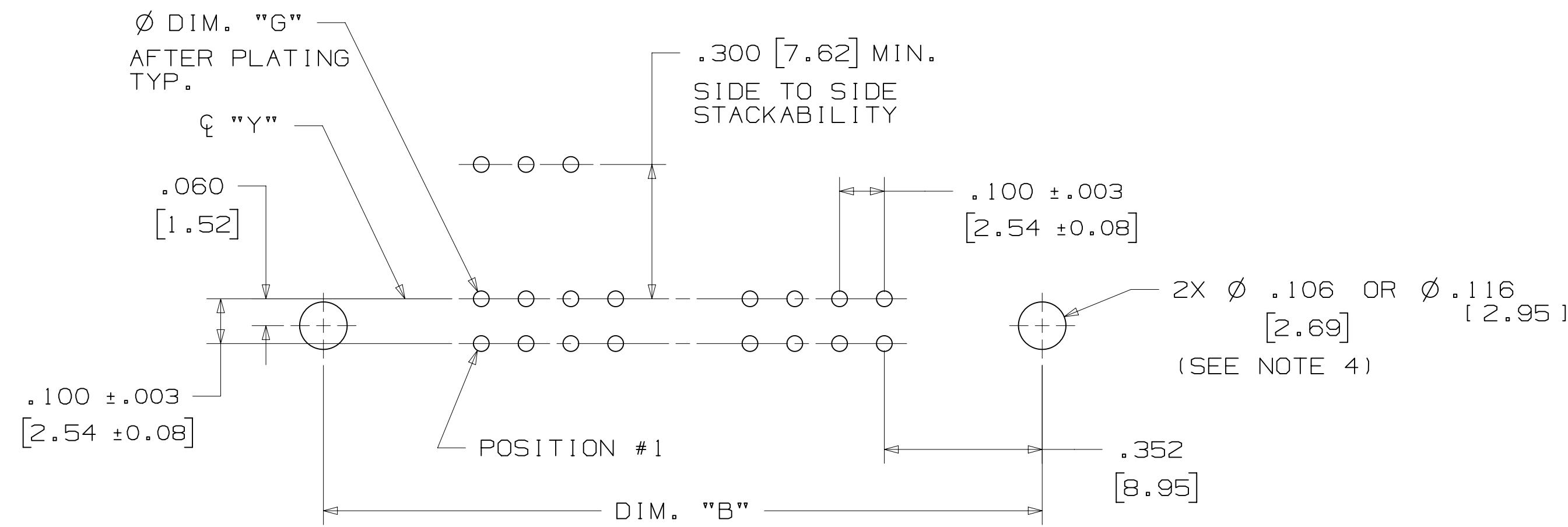

RECOMMENDED MOUNTING HOLE PATTERN (STRAIGHT VERSION)

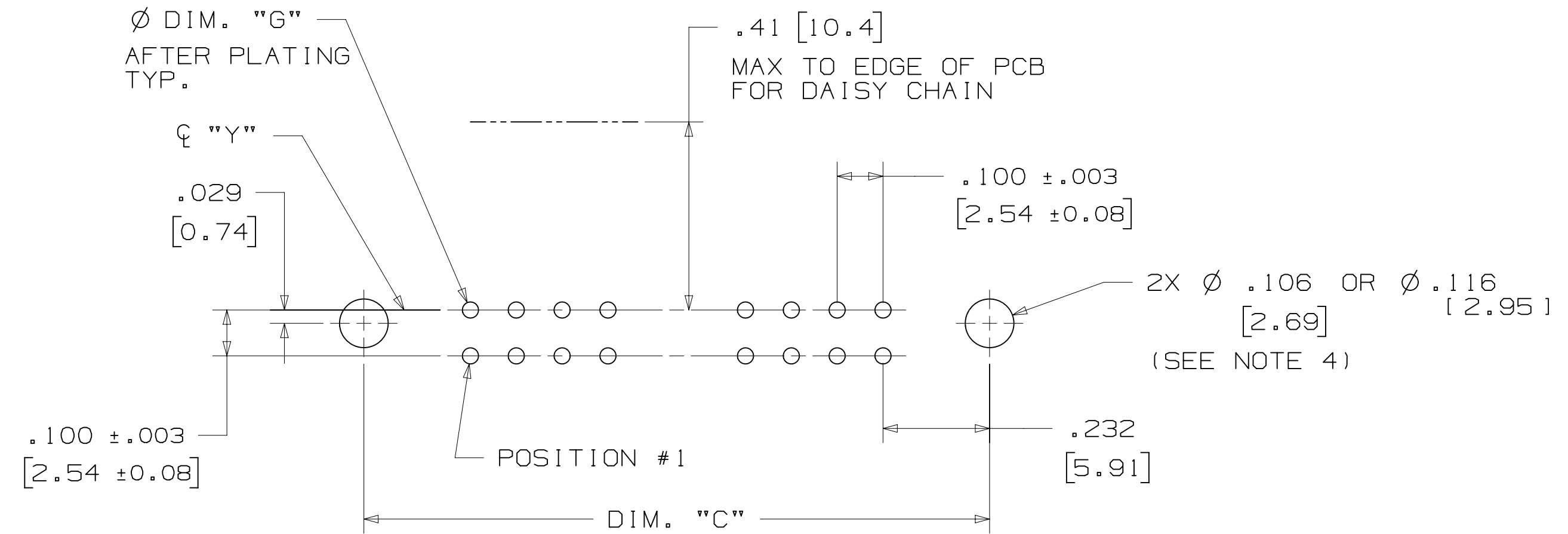

RECOMMENDED MOUNTING HOLE PATTERN (RIGHT ANGLE VERSION)

PART CUSTOMIZATION

THIS SPEC SHEET DETAILS OUR STANDARD OFFERING.

3M HAS SEVERAL CAPABILITIES THAT CAN PROVIDE A PART TAILORED TO YOUR SPECIFIC NEEDS. ASK YOUR 3M SALES REPRESENTATIVE OR CUSTOMER SERVICE FOR MORE DETAILS.

BOTH SNAP-IN AND ROLL PIN LATCHES MAY BE ORDERED SEPARATELY. SNAP-IN AND ROLL PIN STYLE LATCHES ARE DIMENSIONALLY AND FUNCTIONALLY EQUIVALENT. IF ORDERING SNAP-IN OR ROLL PIN STYLE LATCHES SEPARATELY, PLEASE USE THE BELOW CHART.

MATERIAL	SHORT LATCH	LONG LATCH	LATCH STYLE	COLOR
HIGH TEMP. (PCT)	N3505-2B	N3505-3B	ROLL PIN	BLACK
HIGH TEMP. (PPA)	N3505-30B	N3505-31B	SNAP-IN	BLACK

- * SELECTIVE PIN REMOVAL (ATA OR OTHER COMPATABILITY)
- * WIRE WRAP TAILS STYLE

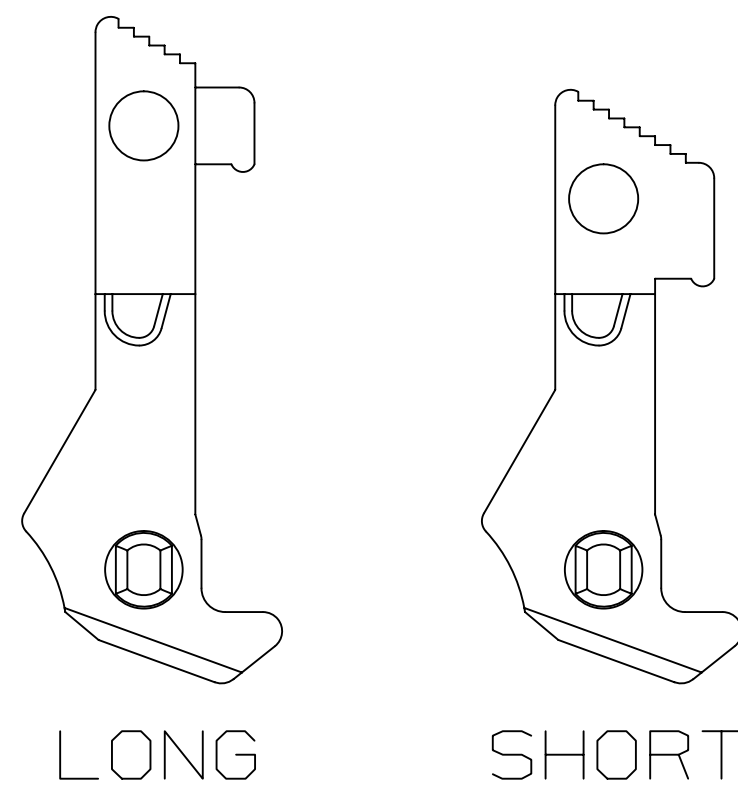

SNAP-IN LATCHES

NOTE: SNAP-IN LATCHES CAN ONLY BE ORDERED SEPARATELY AND ARE THE CUSTOMERS RESPONSIBILITY TO INSTALL.

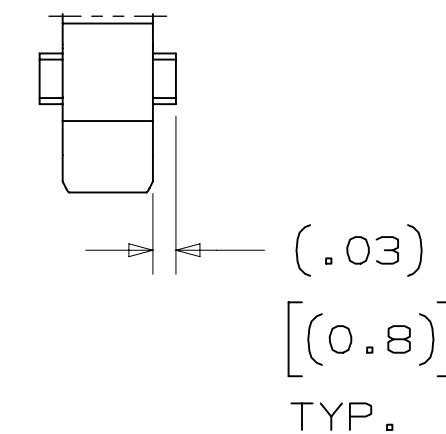

POLARIZING POST

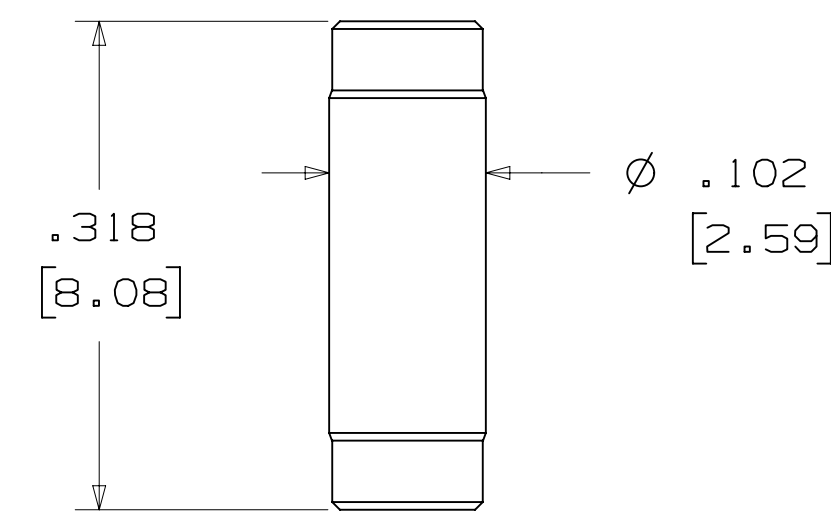

3M PART NO.	MATERIAL	COLOR
3201-4	LCP	BLACK

NOTE: INSERT POST INTO ONE MOUNTING HARDWARE HOLE ON BOTTOM OF HEADER. SET POST TO PROTRUDE .115 [2.92]

K2 OPTION

2500 & 3000 SERIES SHROUDED HEADER						
TOTAL NO. OF PINS	NO. OF TAILS KINKED	POSITIONS KINKED				
10	4	3	4	7	8	
14	4	3	4	11	12	
16	4	3	4	13	14	
20	4	3	4	17	18	
24	4	3	4	21	22	
26	4	3	4	23	24	
30	4	5	6	25	26	
34	4	7	8	27	28	
36	4	7	8	27	28	
40	4	7	8	33	34	
50	4	7	8	43	44	
60	4	11	12	49	50	
64	4	11	12	53	54	

KINKED TAIL DETAIL:
 - KINK IS LOCATED .05" BELOW BOTTOM SURFACE OF PLASTIC.
 - EXTERNAL RADIUS OF KINK TOWARD PART CENTERLINE.

POLARIZING KEYS

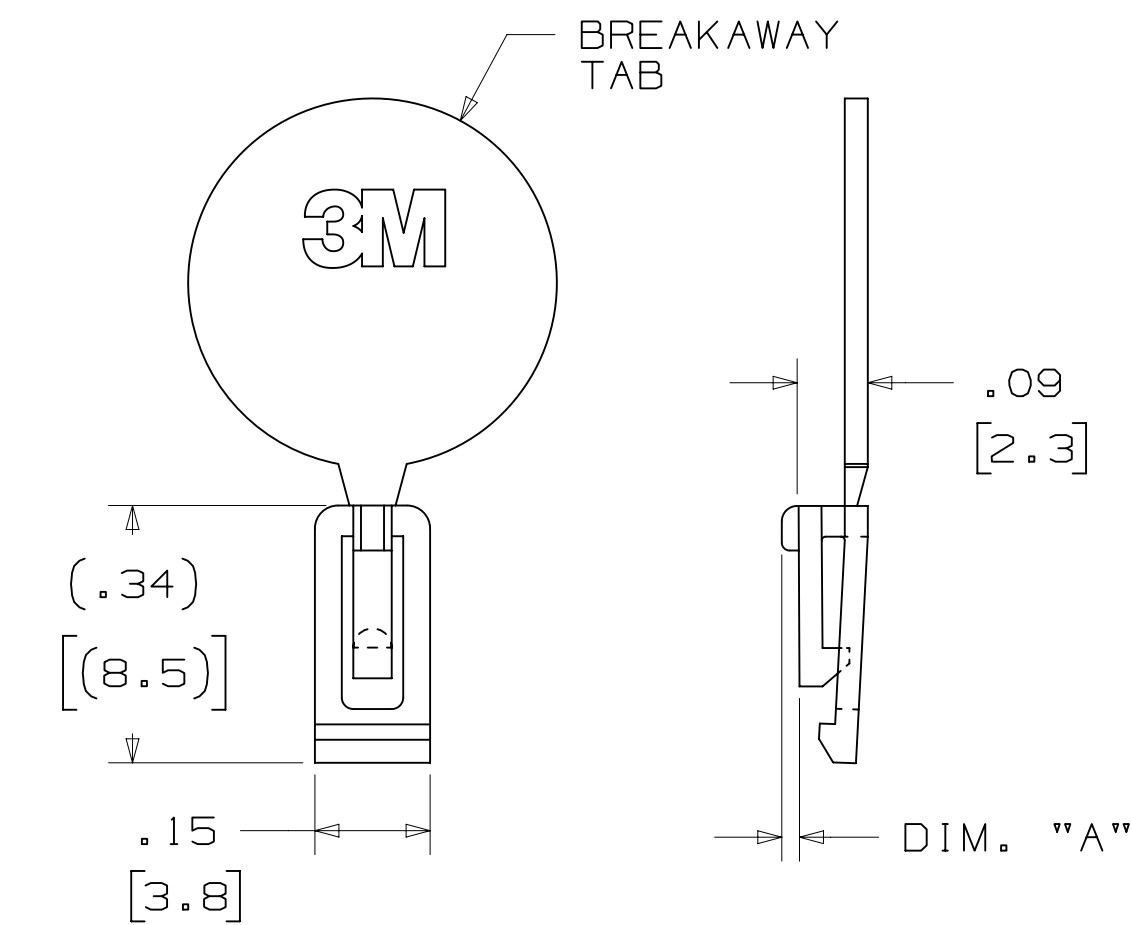

3M PART NO.	MATERIAL	COLOR	DIM. "A"
N3518	LCP	BLACK	.02

NOTE: #2216 B/A SCOTCHWELD CAN BE USED TO ADHERE KEYS.

DESIGN REFERENCE	NEXT ASSEMBLY	REV	ECO	ISSUE DATE AND DESCRIPTION	DRFT	CHKD
		S	60056	MAR 06, 2015 REVISE ORDERING NUMBER	JNC	RS
		R	56068	JUL 25, 2014 REVISED AND REDRAWN	JNC	RS
		CHKD		DATE JUL 25, 2014	DATE SEP 05, 2014	
		APPV		DATE JUL 25, 2014	DATE SEP 05, 2014	
				DATE JUL 25, 2014	DATE SEP 05, 2014	

DIVISION	DIVISION CODE
Interconnect Solutions	EMSD

DO NOT SCALE DRAWING	SCALE	TOLERANCES EXCEPT AS NOTED
	4 1	

INTERPRET PER ASME Y14.5 - 2009	TOLERANCES EXCEPT AS NOTED

MAX SURFACE ROUGHNESS	MILLIMETERS

TITLE	DATE
HEADER, 4-WALL, .100 X .100 LATCH/EJECTOR, STRAIGHT & RA	

CAGE NUMBER	SIZE	DRAWING NO.	REV.
D		78-5100-0772-3	S

MODEL	DEF	LISTS	YES	NO	SHT	OF
3000 SERIES					3	4

178-5100-0772-3
 REV. 05/2014
 3/6/2015 12:54 PM UTC-06:00

3M™ FOUR-WALL HEADER, 3000 SERIES
 .100" X .100" LATCH/EJECTOR, STRAIGHT AND RIGHT ANGLE

MOUNTING HARDWARE

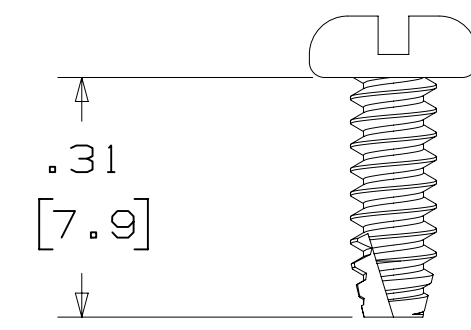

3341-5
 (INSTALL FROM BOTTOM OF BOARD)
 PANHEAD THREAD CUTTING SCREW:
 #4-24 X 5/16"
 TYPE: USA STD BT, FEDERAL BG
 MATERIAL: STAINLESS STEEL

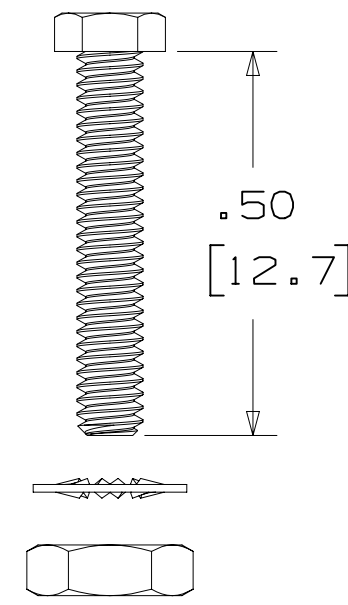

3341-6
 HEX HEAD BOLT, NUT AND WASHER:
 BOLT - #2-56 X 1/2"
 MATERIAL: STAINLESS STEEL

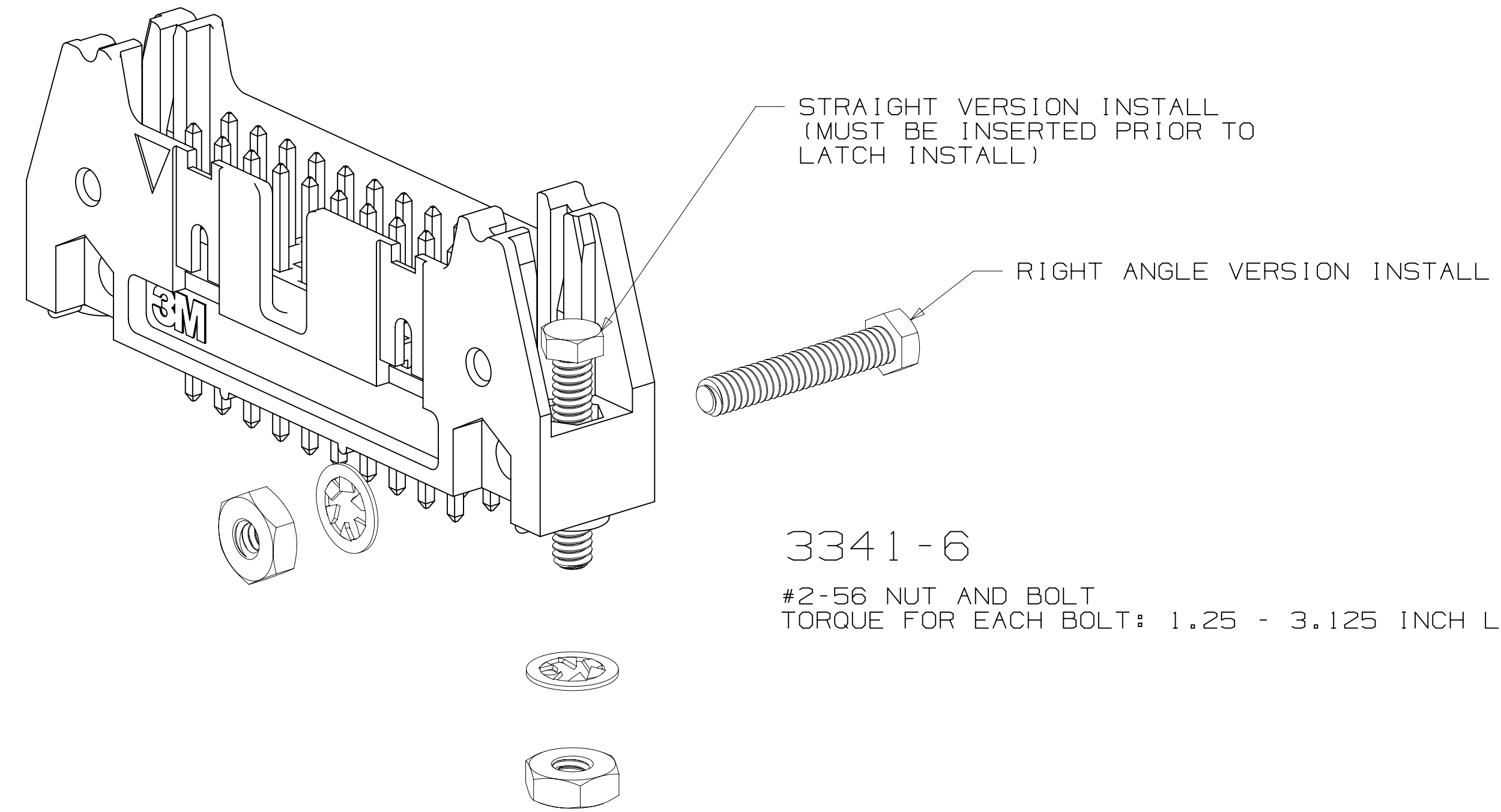

3341-6
 #2-56 NUT AND BOLT
 TORQUE FOR EACH BOLT: 1.25 - 3.125 INCH LBS.

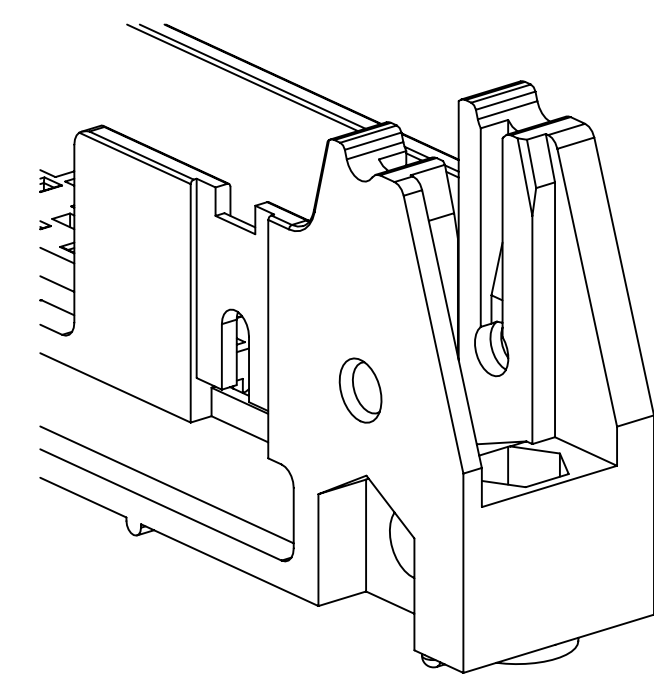

#4-24 TYPE BT SELF THREADING SCREW
 WHEN USING LATCHES, MAXIMUM LENGTH
 OF SCREW IS .250 INCHES PLUS
 THICKNESS OF THE BOARD.
 TORQUE FOR EACH SCREW IS 3-5 INCH LBS.

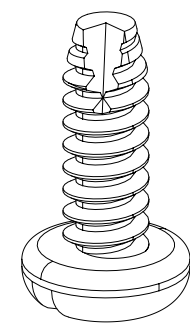

3341-5

DESIGN REFERENCE	NEXT ASSEMBLY	REV	ECO	ISSUE DATE AND DESCRIPTION	DRFT	CHKD
		CASTIGLIONE		JUL 25, 2014		
					R. SCHERER	SEP 05, 2014
DIVISION	DIVISION CODE	© 3M COPYRIGHT 2015 This document and the information it contains are 3M property and may not be reproduced or further distributed without 3M permission, or used or disclosed other than for 3M authorized purposes. All rights reserved.				
Interconnect Solutions	EMSD	TITLE: HEADER, 4-WALL, .100 X .100 LATCH/EJECTOR, STRAIGHT & RA CAGE NUMBER: D78-5100-0772-3 MODEL: 3000 SERIES SHEET: 4 OF 4				
DO NOT SCALE DRAWING	SCALE: 4/1	TOLERANCES EXCEPT AS NOTED: INCHES: .00 ± .01, .000 ± .005, .0000 ± MILLIMETERS: 0 ±, .0 ± .3, .00 ± .13 MAX SURFACE ROUGHNESS: SURFACES MARKED ONLY				
THIRD ANGLE PROJECTION	INTERPRET PER ASME Y14.5 - 2009	INTERPRET PER ASME Y14.5 - 2009				

78-5100-0772-3
 DRAWING NUMBER
 S
 REVISION
 12:54 PM UTC-06:00
 3/6/2015
 S.1
 Imaged: