

# 3M™ FOUR-WALL HEADER, 3000 SERIES

.100" X .100" LATCH/EJECTOR, STRAIGHT AND RIGHT ANGLE

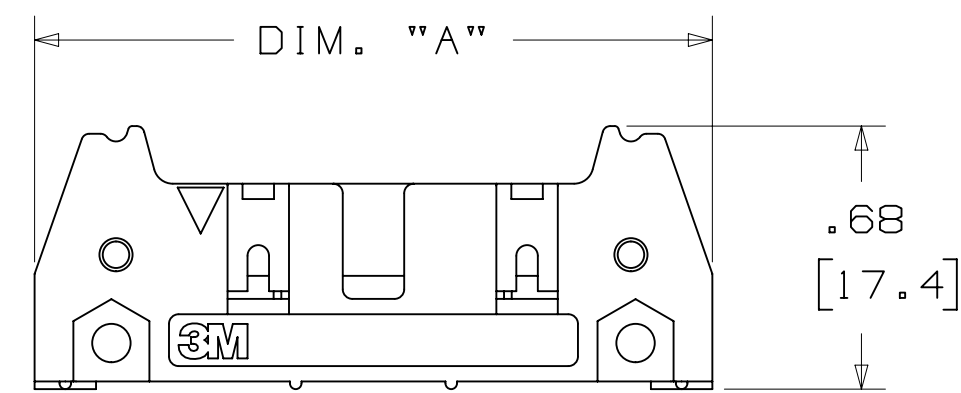

-X0XX  
HEADER WITHOUT LATCH/EJECTOR

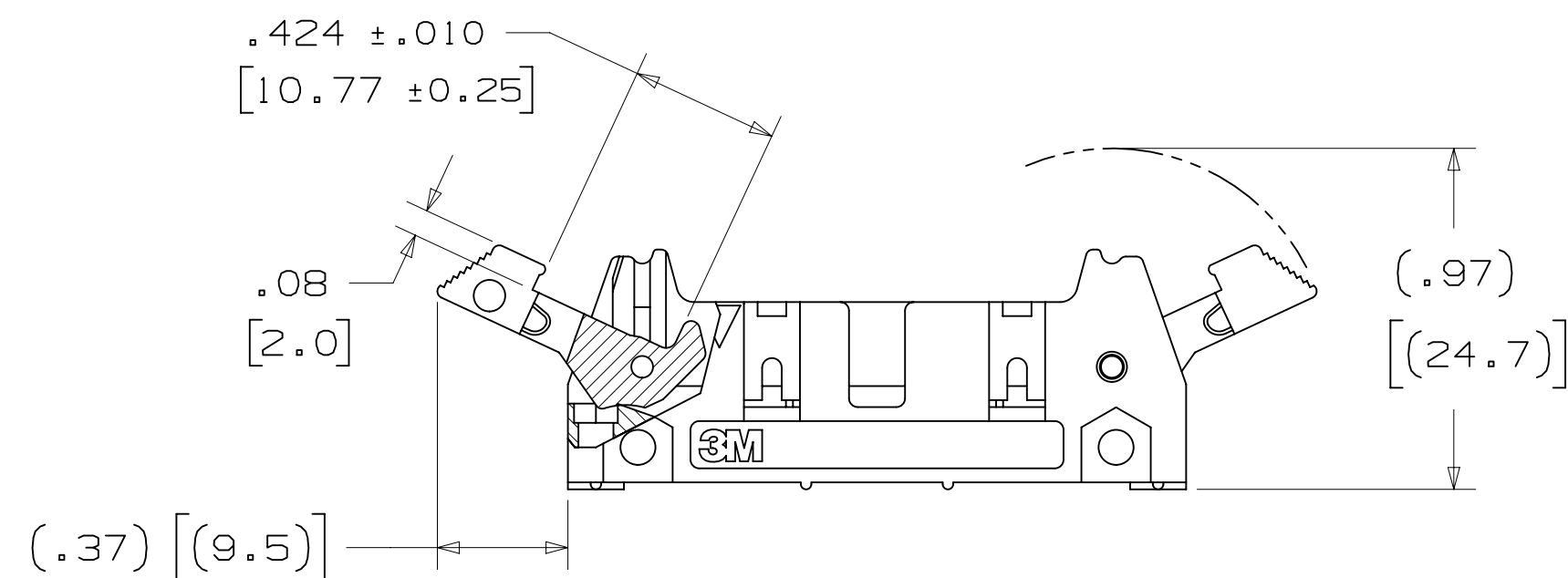

-X2XX  
HEADER WITH SHORT LATCH/EJECTOR  
FOR 3M SOCKETS WITHOUT STRAIN RELIEF

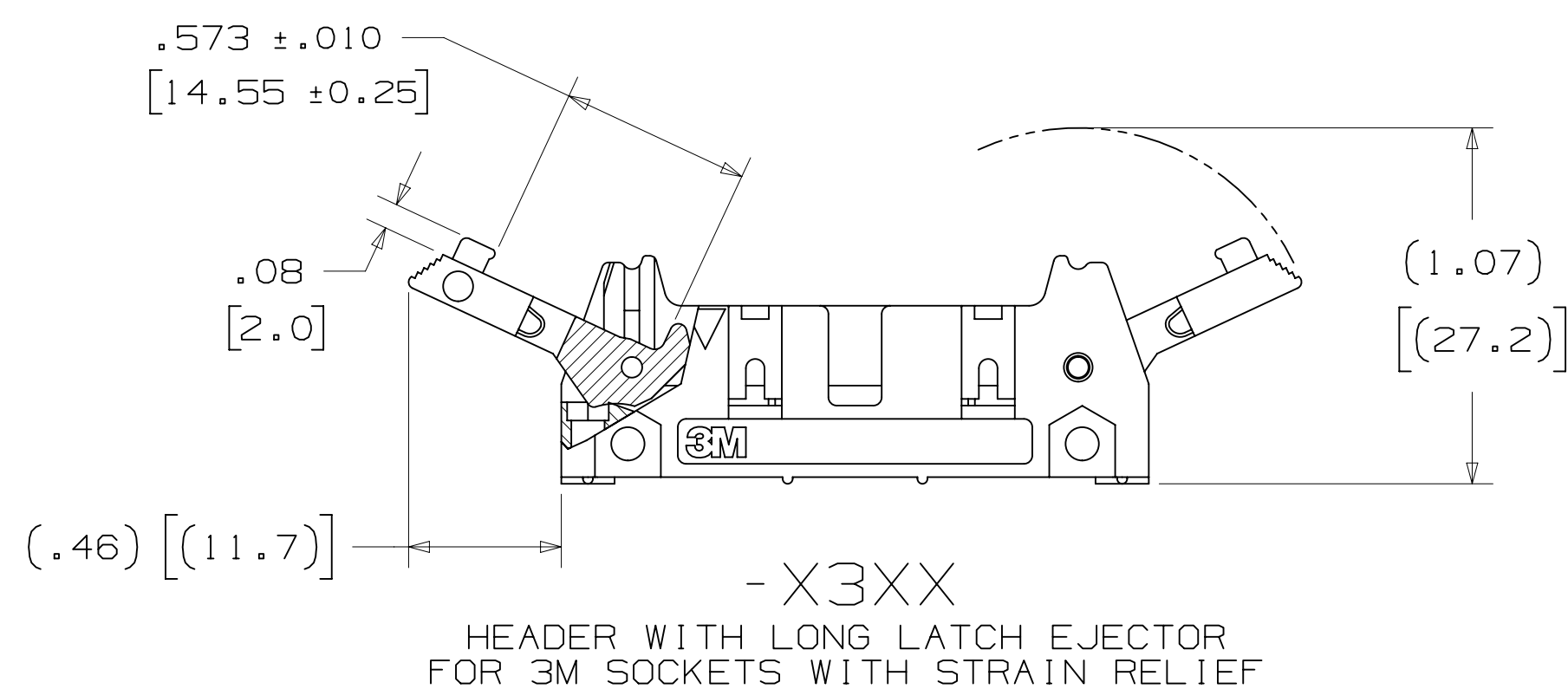

-X3XX  
HEADER WITH LONG LATCH/EJECTOR  
FOR 3M SOCKETS WITH STRAIN RELIEF

- \* MILITARY (WITH 3M'S N3518 POLARIZING KEY) AND CENTERBUMP POLARIZATION.
- \* OPTIONAL EJECTOR LATCHES.
- \* MOUNTING HOLES FOR SECURING HEADER TO BOARD.
- \* OPTIONAL POLARIZING POSTS AVAILABLE.
- \* HIGH TEMPERATURE INSULATOR SUITABLE FOR "NO LEAD" SOLDERING OPERATIONS.
- \* SUITABLE FOR REFLOW SOLDERING USING "PASTE IN HOLE" TECHNIQUES.
- \* SOLDER TAIL OPTION.

## 2 PHYSICAL :

INSULATOR: GLASS FILLED POLYESTER (PCT)  
 MATERIAL: UL94V-0  
 FLAMMABILITY: UL94V-0  
 COLOR: BLACK  
 CONTACT: COPPER ALLOY  
 PLATING: 100μ" [2.54μm] NICKEL-OVERALL  
 UNDER PLATING: 30μ" [0.76μm] AVG. GOLD  
 WIPING AREA: TIN LEAD OR MATTE TIN (SEE ORDERING INFORMATION)  
 MARKINGS: 3M LOGO, PART IDENTIFICATION NUMBER AND ORIENTATION TRIANGLE

## 2 ELECTRICAL :

CURRENT RATING: 5.00A, 1 CONTACT POWERED  
 3.00A, 6 CONTACTS POWERED  
 1.75A, ALL CONTACTS POWERED  
 RATING CONDITIONS: EIA-364-070 METHOD 2, 30°C MAXIMUM TEMPERATURE RISE, 20% DERATED. REFERENCE APPROPRIATE 3M PRODUCT SPECIFICATION FOR DETAILED CURRENT DERATING CURVES.  
 INSULATION RESISTANCE: >1 X 10<sup>9</sup>Ω AT 500 V<sub>DC</sub>  
 WITHSTANDING VOLTAGE: 1,000V<sub>RMS</sub> AT SEA LEVEL

## 2 ENVIRONMENTAL :

TEMPERATURE RATING: -55°C TO 105°C  
 PROCESS RATING: 260°C, PER J-STD-020C, SINGLE PASS  
 MOISTURE SENSITIVITY LEVEL: 1 (PER J-STD-020C)

1. REGULATORY INFORMATION: ROHS COMPLIANT. SEE THE REGULATORY INFORMATION APPENDIX (RIA) IN THE "ROHS COMPLIANCE" SECTION OF WWW.3MCONNECTORS.COM FOR COMPLIANCE INFORMATION.
2. IN THE EVENT OF CONFLICT BETWEEN THIS DATA AND THAT CONTAINED IN THE PRODUCT SPECIFICATION, THE PRODUCT SPECIFICATION TAKES PRECEDENT.
3. NOTCHES A & C WILL ACCOMMODATE 3M POLARIZING KEY: N3518.
4. MOUNTING HARDWARE: FROM SOLDER SIDE OF PC BOARD USE #4-24 THREAD CUTTING SCREW (3M PART #3341-5) WITH Ø.116 [2.95] MOUNTING HOLE. FOR RIGHT ANGLE VERSION ONLY: #2-56 BOLT AND NUT (3M PART #3341-6) WITH Ø.106 [2.69] MOUNTING HOLE MAY BE USED.
5. THE RECOMMENDED PCB HOLE SIZE FOR THE KINKED TAIL POSITIONS ON THE .112 SOLDER TAIL CONNECTOR IS Ø.035±.002. (SEE K2 VERSION).

## ORDERING INFORMATION

X3XXX - XXXXXX

N = HIGH TEMP BLACK (PCT)/(RB PLATING REQ'D)  
 BLANK = (UB PLATING)

3M PART NUMBER:  
 (SEE TABLE 1)

PIN CONFIGURATION:  
 5 = RIGHT ANGLE SOLDER TAILS  
 6 = STRAIGHT SOLDER TAILS

PLATING:

RB = 30μ" [0.76μm] GOLD AND 200μ" [5.08μm] MATTE TIN (APP. E1 & C1 APPLY)  
 UB = 30μ" [0.76μm] GOLD AND 200μ" [5.08μm] TIN LEAD (APP. E3 & C2 APPLY)

TAIL:

O2 = FOR .062 [1.57] THICK BOARD  
 O3 = FOR .094 TO .125 [2.39 TO 3.18] THICK BOARD  
 K2 = KINKED FOR .062 [1.57] THICK BOARD

LATCH/EJECTOR SYSTEM:

0 = NO LATCH/EJECTOR INSTALLED  
 2 = SHORT ROLL PIN LATCH/EJECTORS  
 3 = LONG ROLL PIN LATCH/EJECTORS

DIMENSIONS: INCHES [MM]  
 [MM] IS REF. ONLY

DESIGN REFERENCE	NEXT ASSEMBLY	REV	ECO	ISSUE DATE AND DESCRIPTION	DRFT	CHKD																
		S	60056	MAR 06, 2015 REVISE ORDERING NUMBER	JNC	RS																
		R	56068	JUL 25, 2014 REVISED AND REDRAWN	JNC	RS																
DRW CODES		CHKD	CASTIGLIONE	DATE JUL 25, 2014	APPR R. SCHERER	DATE SEP 05, 2014																
DIVISION	Interconnect Solutions	DIVISION CODE	EMSD	© 3M COPYR[IGHT] 2015 This document and the information it contains are 3M property and may not be reproduced or further distributed without 3M permission, or used or disclosed other than for 3M authorized purposes. All rights reserved.																		
DO NOT SCALE DRAWING	SCALE 1	TOLERANCES EXCEPT AS NOTED	<table border="1"> <tr> <td colspan="2">INCHES</td> </tr> <tr> <td>.0</td> <td>±.01</td> </tr> <tr> <td>.000</td> <td>±.005</td> </tr> <tr> <td>.0000</td> <td>±</td> </tr> <tr> <td colspan="2">MILLIMETERS</td> </tr> <tr> <td>0</td> <td>±.3</td> </tr> <tr> <td>.0</td> <td>±.13</td> </tr> <tr> <td>.000</td> <td>±</td> </tr> </table>				INCHES		.0	±.01	.000	±.005	.0000	±	MILLIMETERS		0	±.3	.0	±.13	.000	±
INCHES																						
.0	±.01																					
.000	±.005																					
.0000	±																					
MILLIMETERS																						
0	±.3																					
.0	±.13																					
.000	±																					
THIRD ANGLE PROJECTION	INTERPRET PER ASME Y14.5 - 2009	MAX SURFACE ROUGHNESS	<table border="1"> <tr> <td>DTX SURFACES</td> <td>ANGLES</td> </tr> <tr> <td>✓</td> <td>✓</td> </tr> </table>				DTX SURFACES	ANGLES	✓	✓												
DTX SURFACES	ANGLES																					
✓	✓																					
TITLE		CAGE NUMBER	SIZE	DRAWING NO.	REV.																	
HEADER, 4-WALL, .100 X .100 LATCH/EJECTOR, STRAIGHT & RA		D		78-5100-0772-3	S																	
MODEL		3000 SERIES	DET	ISTS	YES	NO																
					SHT	1 OF 4																

3M ELECTRONIC MATERIALS SOLUTIONS DIVISION  
 INTERCONNECT SOLUTIONS  
<http://www.3mconnectors.com>

3M IS A TRADEMARK OF 3M COMPANY.  
 FOR TECHNICAL, SALES OR ORDERING  
 INFORMATION CALL 800-225-5373

**CAUS**  
 UL FILE NO: E68080

78-5100-0772-3  
 DRAWING NUMBER  
 12:54 PM UTC-06:00  
 S  
 REVISION  
 B  
 C  
 D

# 3M™ FOUR-WALL HEADER, 3000 SERIES

.100" X .100" LATCH/EJECTOR, STRAIGHT AND RIGHT ANGLE

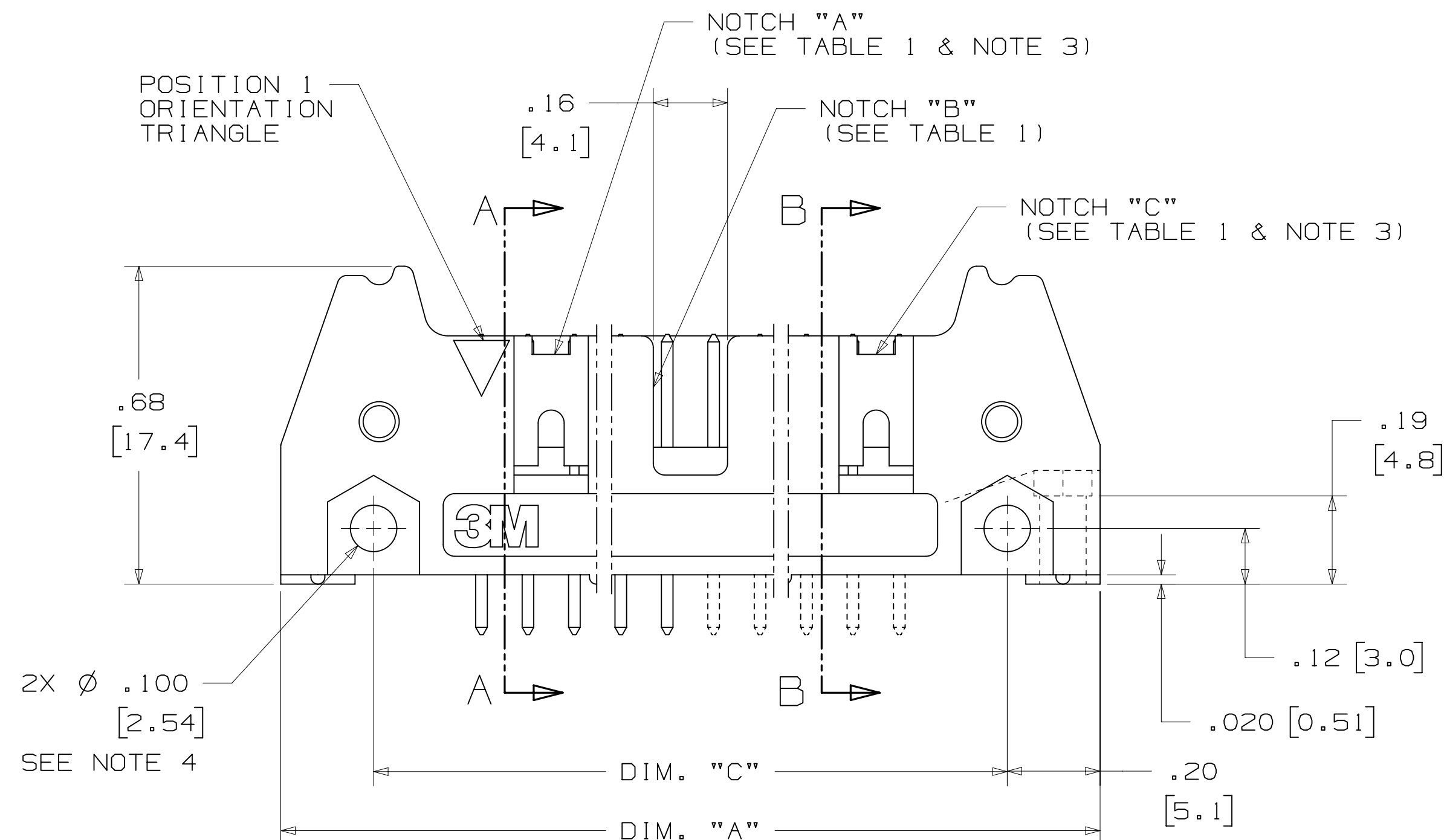
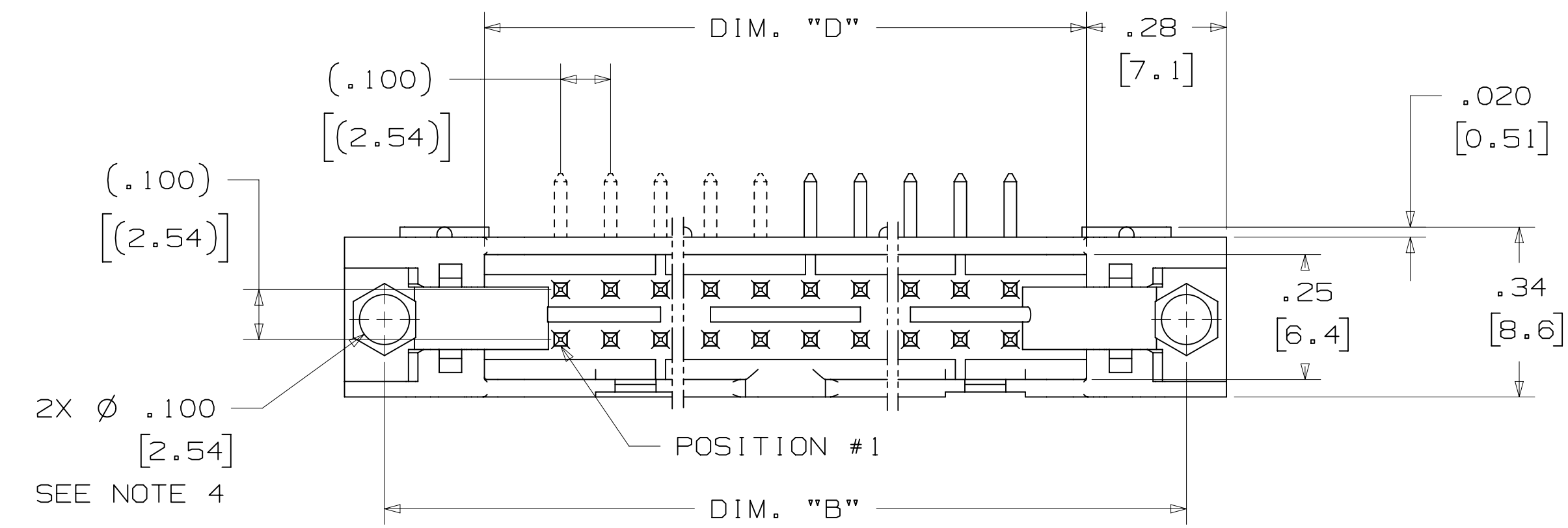
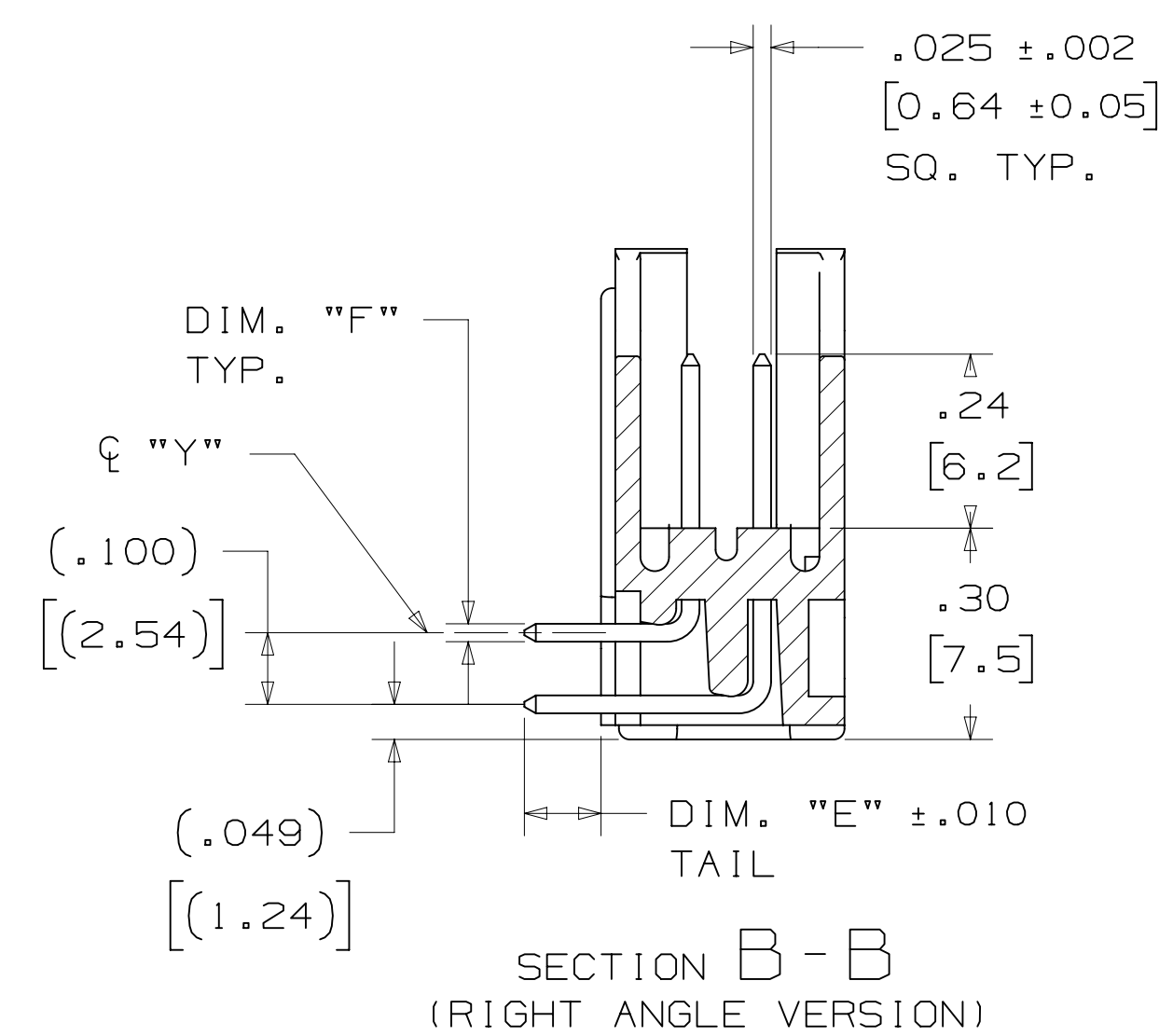
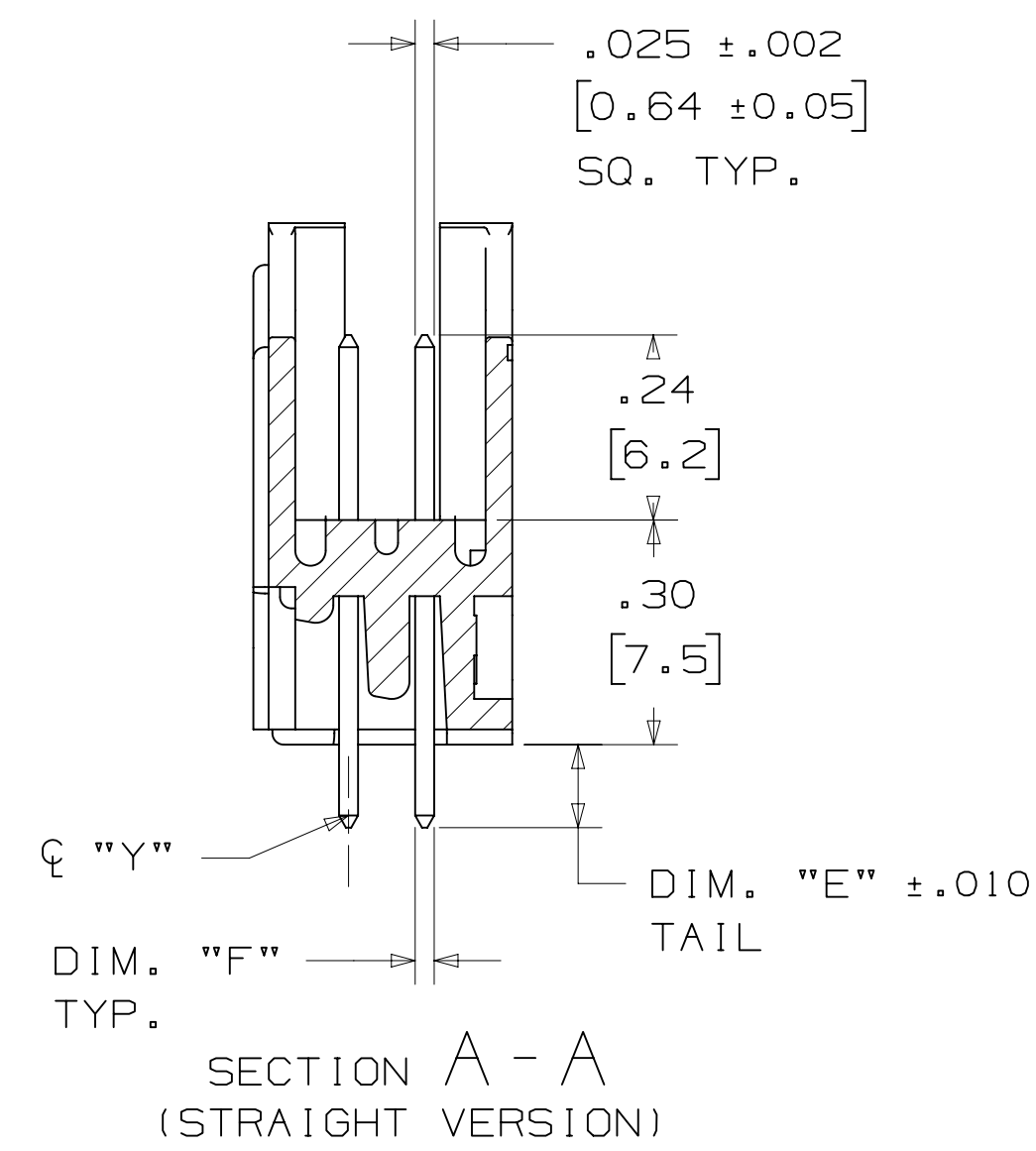

PIN QTY.	3M PART NUMBER	DIM. "A"	DIM. "B"	DIM. "C"	DIM. "D"	POLARIZING NOTCHES	PIN QTY.
06	3869	1.06 [27.0]	.905 [22.99]	.665 [16.89]	.51 [12.9]	B*	06
08	3889	1.16 [29.5]	1.005 [25.53]	.765 [19.43]	.61 [15.5]	B*	08
10	3793	1.26 [32.1]	1.105 [28.04]	.865 [21.97]	.71 [18.0]	BC	10
14	3314	1.46 [37.2]	1.305 [33.12]	1.065 [27.05]	.91 [23.1]	BC	14
16	3408	1.56 [39.7]	1.405 [35.66]	1.165 [29.59]	1.01 [25.6]	ABC	16
20	3428	1.76 [44.8]	1.604 [40.74]	1.365 [34.67]	1.21 [30.7]	ABC	20
24	3627	1.96 [49.9]	1.805 [45.82]	1.565 [39.75]	1.41 [35.8]	ABC	24
26	3429	2.06 [52.4]	1.905 [48.36]	1.665 [42.29]	1.51 [38.3]	ABC	26
30	3440	2.26 [57.5]	2.105 [53.44]	1.865 [47.37]	1.71 [43.4]	ABC	30
34	3431	2.46 [62.6]	2.305 [58.52]	2.065 [52.45]	1.91 [48.5]	ABC	34
40	3432	2.76 [70.2]	2.605 [66.14]	2.365 [60.07]	2.21 [56.1]	ABC	40
50	3433	3.26 [82.9]	3.105 [78.84]	2.865 [72.77]	2.71 [68.8]	ABC	50
60	3372	3.76 [95.6]	3.605 [91.54]	3.365 [85.47]	3.21 [81.5]	ABC	60
64	3764	3.96 [100.7]	3.805 [96.62]	3.565 [90.55]	3.41 [86.6]	ABC	64

\* AVAILABLE WITHOUT CENTER NOTCH B. CONTACT 3M

3M PART NUMBER SUFFIX	CONTACT TAIL	DIM. "E"	PIN CROSS SECTION			DIM. "G"
-5XX2	.062 [1.57] THICK PC BOARD	.112 [2.84]	DIM. "F"			.035 +/- .003 [.89] SEE NOTE 5
-6XX2			.0245 +/- .0005 [.622]	.028 +/- .001 [.71]	CORNER RADIUS .0075 REF. [.191]	
-5X03	.094 [2.39] TO .125 [3.18] THICK PC BOARD	.155 [3.94]	DIM. "F"			.035 +/- .003 [.89]
-6X03			.0245 +/- .0005 [.622]	.028 +/- .001 [.71]	.0075 REF. [.191]	

DESIGN REFERENCE	NEXT ASSEMBLY	REV. ECO	ISSUE DATE AND DESCRIPTION	DRFT	CHKD
3M	3M	ECO	JUL 25, 2014	JNC	RS
DO NOT SCALE DRAWING	SCALE 4:1	INTERPRET PER ASME Y14.5 - 2009	TOLERANCES EXCEPT AS NOTED	INCHES .00 .01 .000 .005 .0000 ±	MILLIMETERS 0 ± .3 .00 ± .13 .000 ±
THIRD ANGLE PROJECTION		MAX SURFACE ROUGHNESS	DEF SURFACES	MARKED ONLY	ANGLES
DIVISION: Interconnect Solutions		DIVISION CODE: EMSD			
DATE: JUL 25, 2014		DATE: SEP 05, 2014			
APPR: R. SCHERER		DATE: SEP 05, 2014			
CAGE NUMBER: D78-5100-0772-3		REV. S			
MODEL: 3000 SERIES		SHT 2 OF 4			

78-5100-0772-3  
 3/6/2015 12:54 PM UTC-06:00  
 S  
 REV. S  
 SHT 2 OF 4

# 3M™ FOUR-WALL HEADER, 3000 SERIES

.100" X .100" LATCH/EJECTOR, STRAIGHT AND RIGHT ANGLE

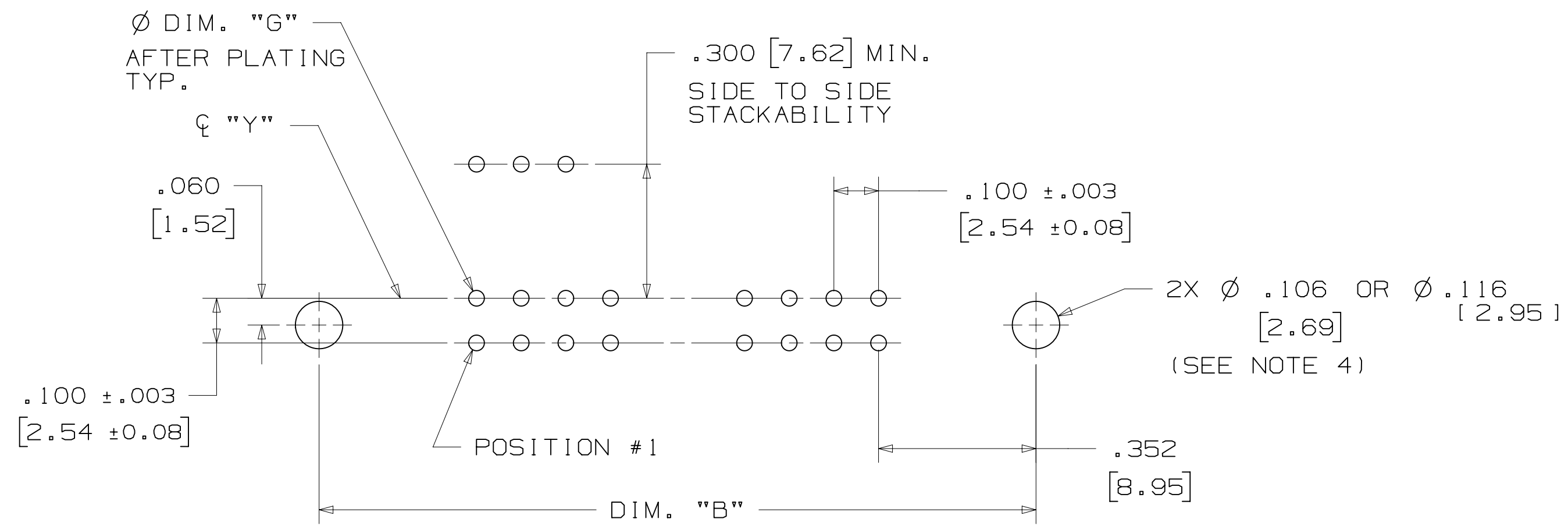

RECOMMENDED MOUNTING HOLE PATTERN (STRAIGHT VERSION)

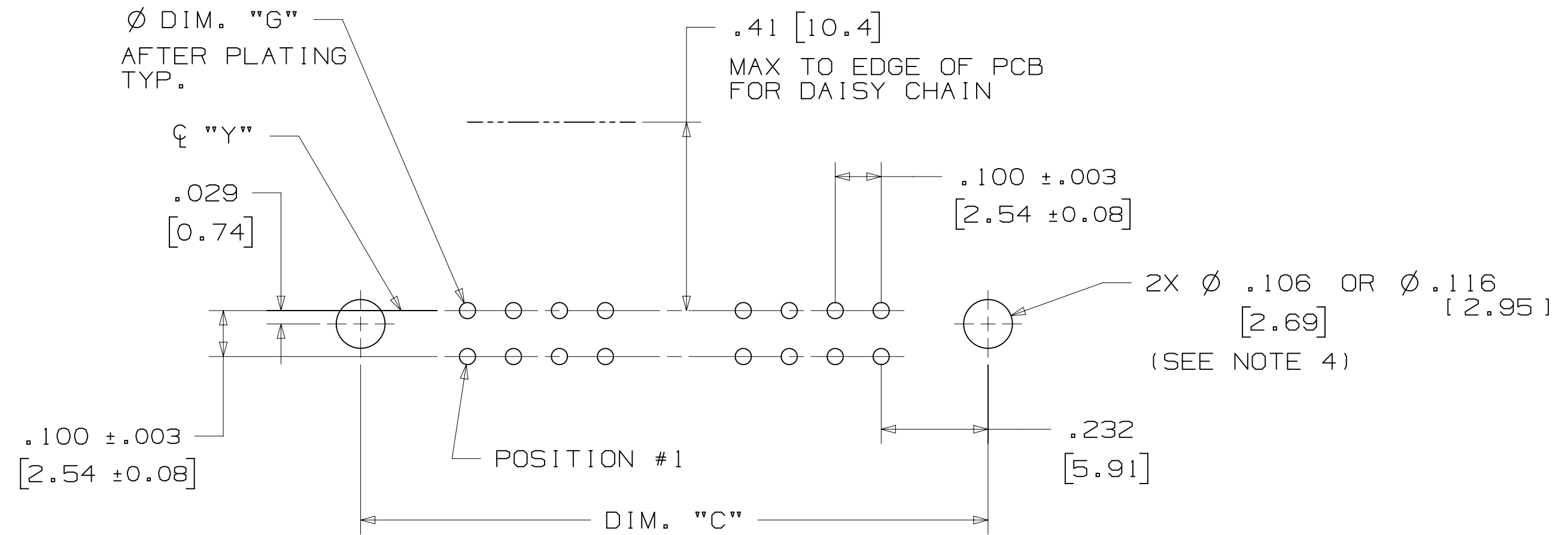

RECOMMENDED MOUNTING HOLE PATTERN (RIGHT ANGLE VERSION)

## PART CUSTOMIZATION

THIS SPEC SHEET DETAILS OUR STANDARD OFFERING.

3M HAS SEVERAL CAPABILITIES THAT CAN PROVIDE A PART TAILORED TO YOUR SPECIFIC NEEDS. ASK YOUR 3M SALES REPRESENTATIVE OR CUSTOMER SERVICE FOR MORE DETAILS.

BOTH SNAP-IN AND ROLL PIN LATCHES MAY BE ORDERED SEPARATELY. SNAP-IN AND ROLL PIN STYLE LATCHES ARE DIMENSIONALLY AND FUNCTIONALLY EQUIVALENT. IF ORDERING SNAP-IN OR ROLL PIN STYLE LATCHES SEPARATELY, PLEASE USE THE BELOW CHART.

MATERIAL	SHORT LATCH	LONG LATCH	LATCH STYLE	COLOR
HIGH TEMP. (PCT)	N3505-2B	N3505-3B	ROLL PIN	BLACK
HIGH TEMP (PPA)	N3505-30B	N3505-31B	SNAP-IN	BLACK

- \* SELECTIVE PIN REMOVAL (ATA OR OTHER COMPATABILITY)
- \* WIRE WRAP TAILS STYLE

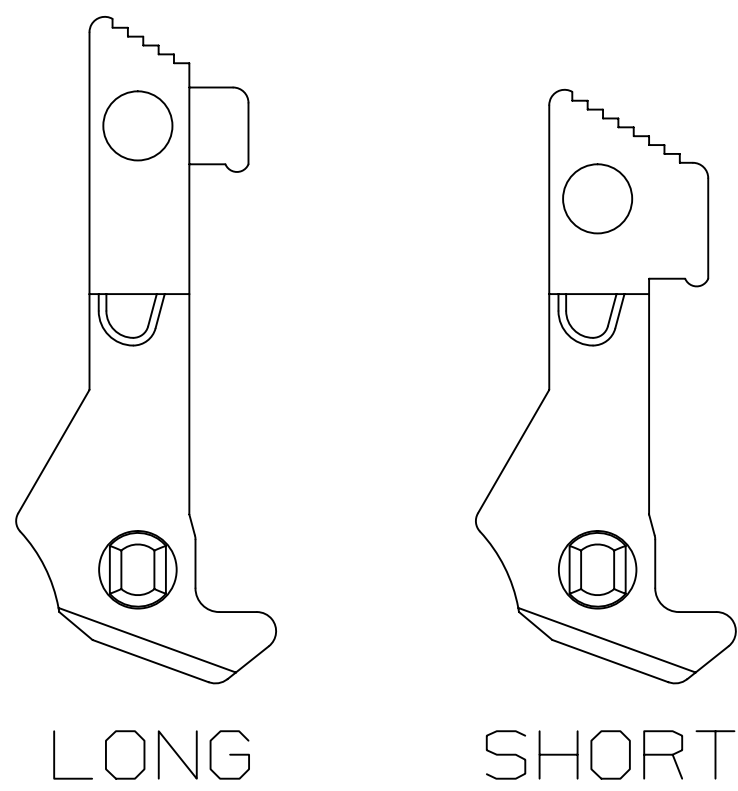

## SNAP-IN LATCHES

NOTE: SNAP-IN LATCHES CAN ONLY BE ORDERED SEPARATELY AND ARE THE CUSTOMERS RESPONSIBILITY TO INSTALL.

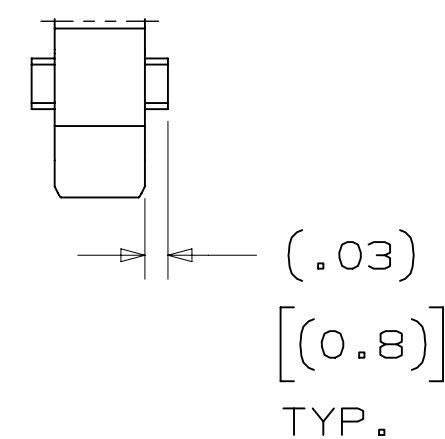

## POLARIZING POST

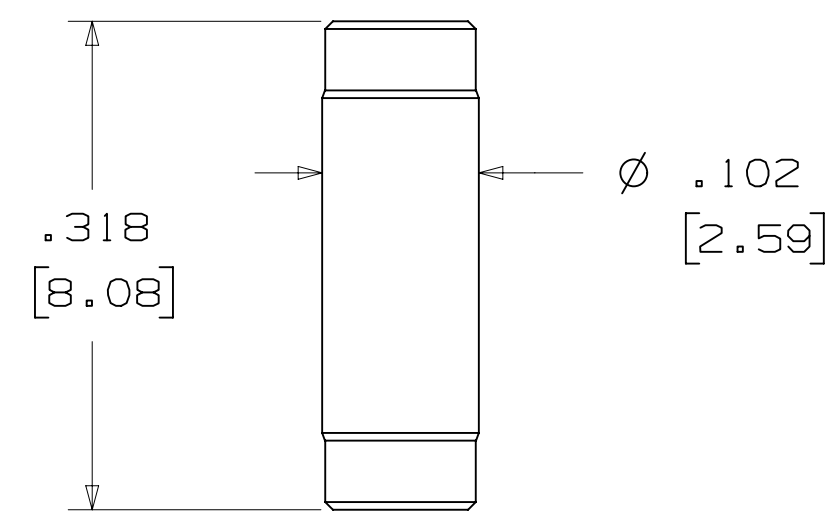

3M PART NO.	MATERIAL	COLOR
3201-4	LCP	BLACK

NOTE: INSERT POST INTO ONE MOUNTING HARDWARE HOLE ON BOTTOM OF HEADER. SET POST TO PROTRUDE .115 [2.92]

## K2 OPTION

2500 & 3000 SERIES SHROUDED HEADER						
TOTAL NO. OF PINS	NO. OF TAILS KINKED	POSITIONS KINKED				
10	4	3	4	7	8	
14	4	3	4	11	12	
16	4	3	4	13	14	
20	4	3	4	17	18	
24	4	3	4	21	22	
26	4	3	4	23	24	
30	4	5	6	25	26	
34	4	7	8	27	28	
36	4	7	8	27	28	
40	4	7	8	33	34	
50	4	7	8	43	44	
60	4	11	12	49	50	
64	4	11	12	53	54	

KINKED TAIL DETAIL:  
 - KINK IS LOCATED .05" BELOW BOTTOM SURFACE OF PLASTIC.  
 - EXTERNAL RADIUS OF KINK TOWARD PART CENTERLINE.

## POLARIZING KEYS

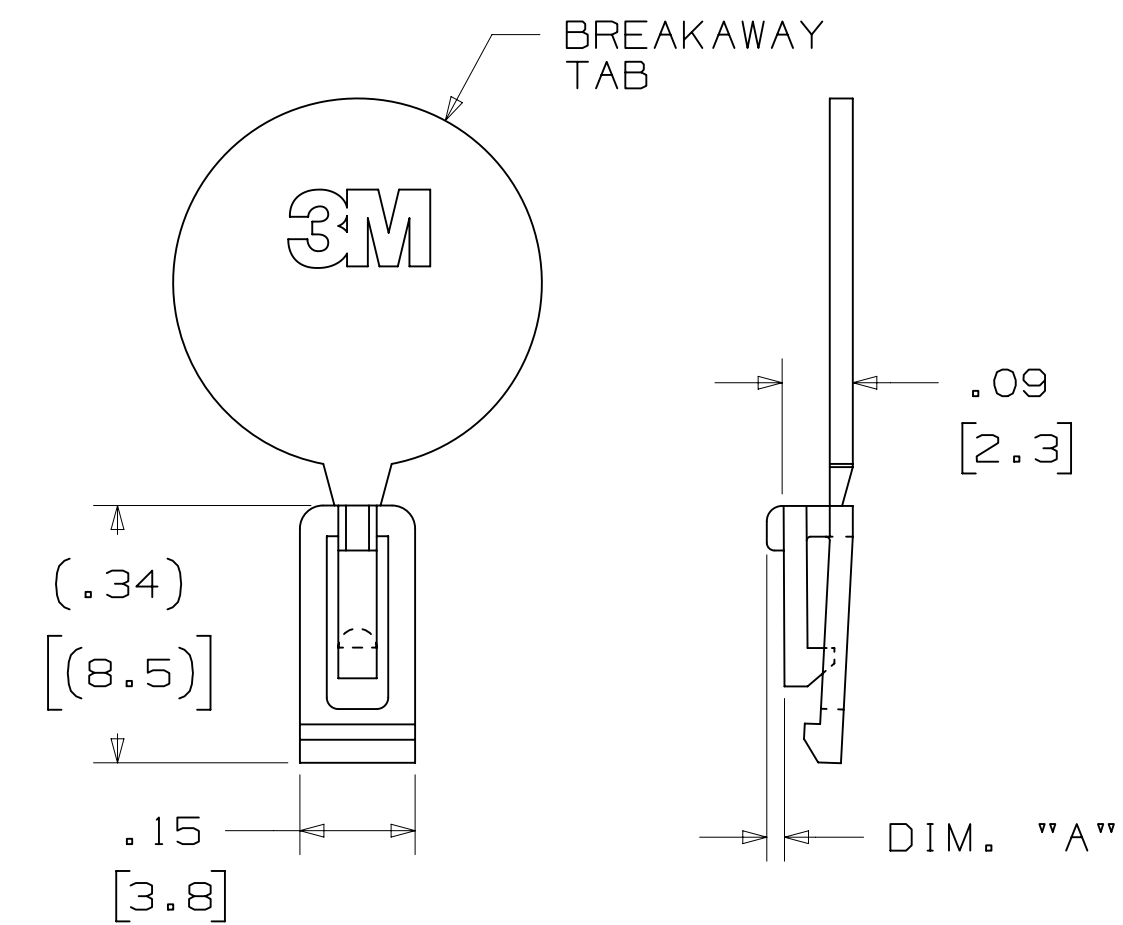

3M PART NO.	MATERIAL	COLOR	DIM. "A"
N3518	LCP	BLACK	.02

NOTE: #2216 B/A SCOTCHWELD CAN BE USED TO ADHERE KEYS.

REV	ECO	ISSUE DATE AND DESCRIPTION	DRFT	CHKD
S	60056	MAR 06, 2015 REVISE ORDERING NUMBER	JNC	RS
R	56068	JUL 25, 2014 REVISED AND REDRAWN	JNC	RS
CHKD	CASTIGLIONE	DATE JUL 25, 2014	DATE	DATE
APPRV	R. SCHERER	DATE SEP 05, 2014		

DESIGN REFERENCE	NEXT ASSEMBLY

DIVISION	DIVISION CODE	TOLERANCES EXCEPT AS NOTED	TITLE
Interconnect Solutions	EMSD	INCHES .00 ± .01 .000 ± .005 .0000 ±	HEADER, 4-WALL, .100 X .100 LATCH/EJECTOR, STRAIGHT & RA
DO NOT SCALE DRAWING	SCALE 4-1	MILLIMETERS 0 ± .0 ± .3 .00 ± .13 .000 ±	CAGE NUMBER D78-5100-0772-3
THIRD ANGLE PROJECTION		MARKED ONLY	REV. S
INTERPRET PER ASME Y14.5 - 2009			MODEL 3000 SERIES
MAX SURFACE ROUGHNESS			DET. <input type="checkbox"/> YES <input checked="" type="checkbox"/> NO SHT 3 OF 4

178-5100-0772-3  
 REV. S  
 3/6/2015 12:54 PM UTC-06:00

3M™ FOUR-WALL HEADER, 3000 SERIES  
 .100" X .100" LATCH/EJECTOR, STRAIGHT AND RIGHT ANGLE

MOUNTING HARDWARE



3341-5

(INSTALL FROM BOTTOM OF BOARD)  
 PANHEAD THREAD CUTTING SCREW:  
 #4-24 X 5/16"  
 TYPE: USA STD BT, FEDERAL BG  
 MATERIAL: STAINLESS STEEL

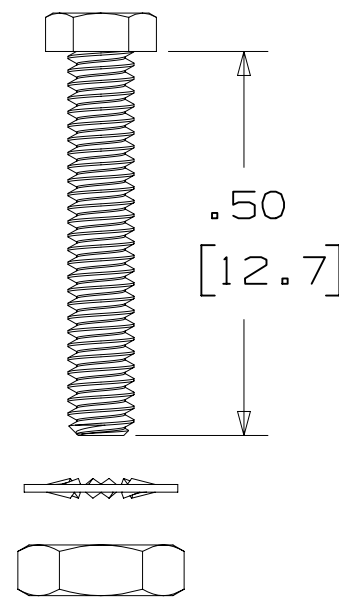

3341-6

HEX HEAD BOLT, NUT AND WASHER:  
 BOLT - #2-56 X 1/2"  
 MATERIAL: STAINLESS STEEL

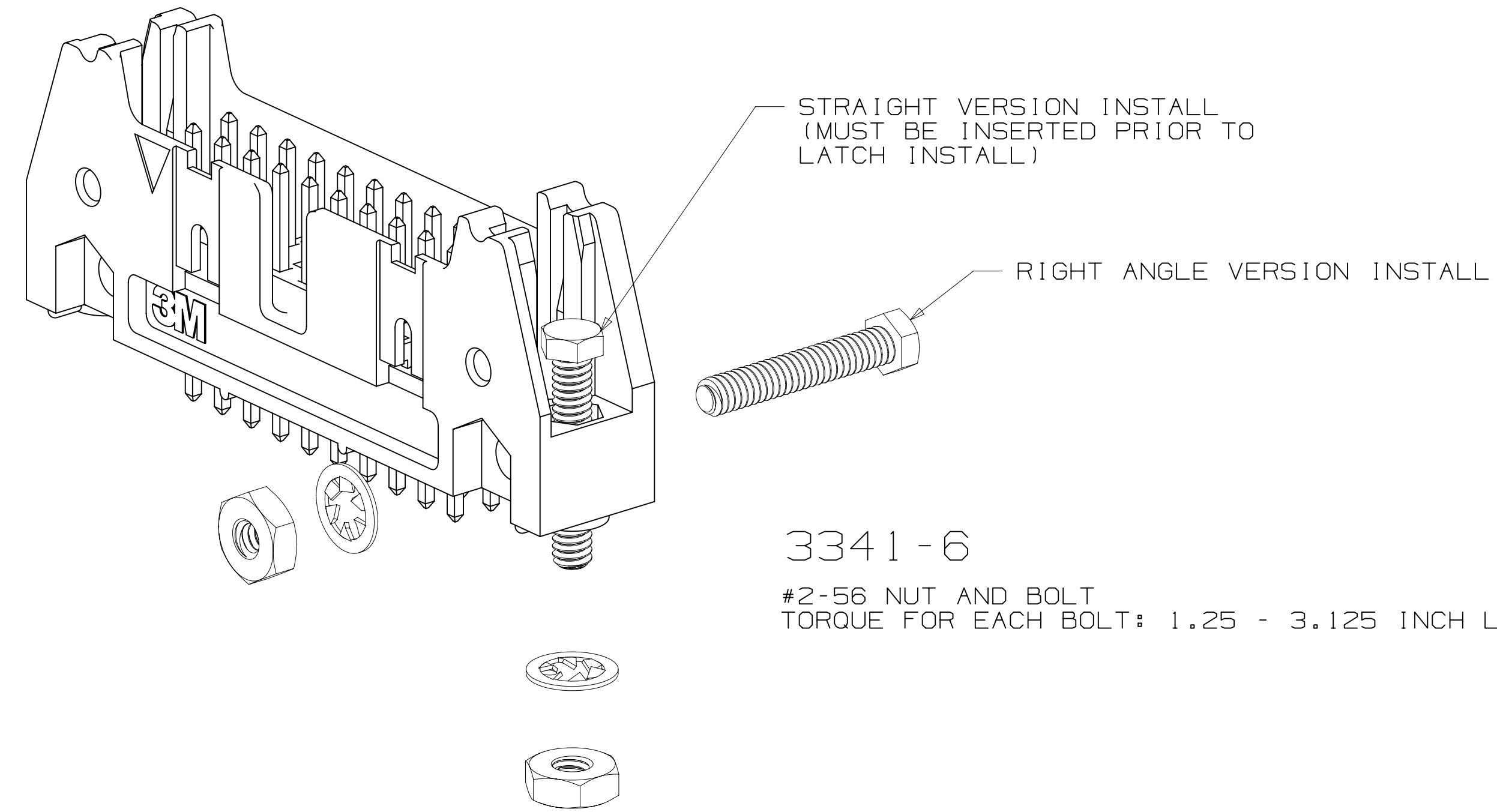

3341-6

#2-56 NUT AND BOLT  
 TORQUE FOR EACH BOLT: 1.25 - 3.125 INCH LBS.

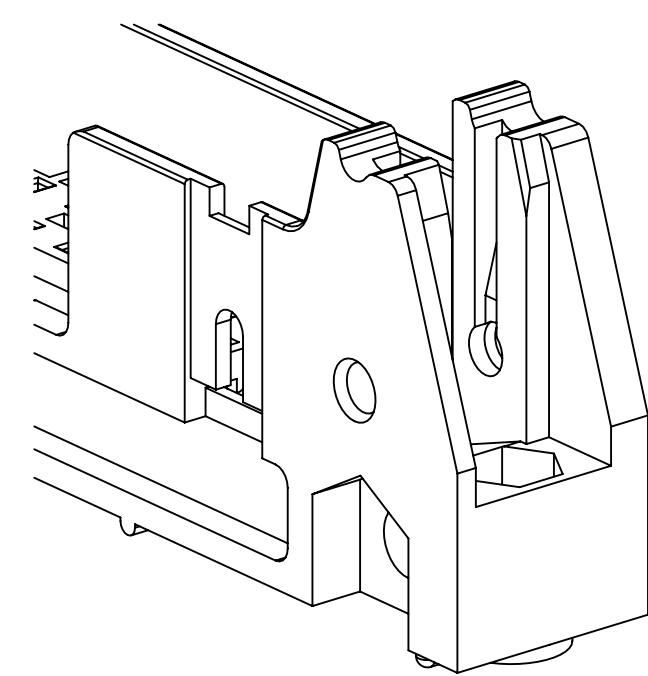

#4-24 TYPE BT SELF THREADING SCREW  
 WHEN USING LATCHES, MAXIMUM LENGTH  
 OF SCREW IS .250 INCHES PLUS  
 THICKNESS OF THE BOARD.  
 TORQUE FOR EACH SCREW IS 3-5 INCH LBS.

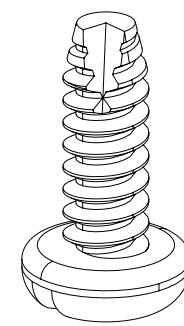

3341-5

DESIGN REFERENCE	NEXT ASSEMBLY	REV	ECO	ISSUE DATE AND DESCRIPTION	DRFT	CHKD
DATE	DATE	DATE	DATE	DATE	DATE	DATE
DIVISION	DIVISION CODE	© 3M COPYRIGHT 2015 This document and the information it contains are 3M property and may not be reproduced or further distributed without 3M permission, or used or disclosed other than for 3M authorized purposes. All rights reserved.				
Interconnect Solutions	EMSD	3M Center St. Paul, MN 55144				
DO NOT SCALE DRAWING	SCALE 4/1	TOLERANCES EXCEPT AS NOTED INCHES .00 ± .01 .000 ± .005 .0000 ±				
THIRD ANGLE PROJECTION	INTERPRET PER ASME Y14.5 - 2009	MILLIMETERS 0 ± .0 ± .3 .00 ± .13 .000 ±				
MAX SURFACE ROUGHNESS	MARKED ONLY	CAGE NUMBER D78-5100-0772-3 S				
		MODEL 3000 SERIES				
		TITLE HEADER, 4-WALL, .100 X .100 LATCH/EJECTOR, STRAIGHT & RA				
		REV. 1 SHT 4 OF 4				

78-5100-0772-3  
 DRAWING NUMBER  
 S  
 REVISION  
 12:54 PM UTC-06:00  
 3/6/2015  
 S.1