

● **Scope**

- ☞ SNR2010K: 0.24uH to 22uH(0.32A ~ 3.70A)
- ☞ SNR2510K: 0.24uH to 15uH(0.50A ~ 3.60A)
- ☞ SNR2512K: 0.24uH to 22uH(0.45A ~ 4.10A)
- ☞ SNR3012K: 0.33uH to 22uH(0.42A ~ 3.00A)
- ☞ SNR3015K: 0.30uH to 47uH(0.35A ~ 4.60A)
- ☞ SNR4012K: 1.00uH to 47uH(0.35A ~ 2.80A)
- ☞ SNR4018K: 0.56uH to 47uH(0.57A ~ 6.50A)
- ☞ SNR4030K: 0.47uH to 150uH (0.50A ~ 7.50A)
- ☞ SNR5020K: 0.22uH to 68uH(0.70A ~ 6.00A)
- ☞ SNR5040K: 1.00uH to 100uH(0.75A ~ 7.35A)
- ☞ SNR6020K: 0.68uH to 47uH(1.00A ~ 7.50A)
- ☞ SNR6028K: 1.00uH to 120uH(0.62A ~ 6.70A)
- ☞ SNR6045K: 1.00uH to 330uH(0.51A ~ 9.00A)
- ☞ SNR8040K: 0.56uH to 680uH(0. 50A~ 11.50A)

● **Features:**

- ☞ Realizes small size and low profile designed.
- ☞ It corresponds to high current.
- ☞ Magnetically shielded construction with magnetic Resin
- ☞ RoHS/HF compliant

● **Applications:**

- ☞ For small DC/DC converter
- ☞ Cellular phone, HDD, DVC, DSC, LCD display etc.
- ☞ **This part is designed for general consuming, while it doesn't meet the automotive spec standard.**

● **Environmental Data:**

- ☞ Operating Temperature: -40°C to 125°C (Including coils self-temperature rise)
- ☞ Storage Temperature Component: -40°C to 125°C.



● Product identification:

SNR **3015** **K** - **4R7** **N**
 (1) (2) (3) (4) (5)

(1) Type: Product type

(2) Dimensions: (Unit: mm)

CODE	Length	Height
2010	2.00	1.00
2510	2.50	1.05
2512	2.50	1.20
3012	3.00	1.20
3015	3.00	1.50
4012	4.00	1.20
4018	4.00	1.85
4030	4.00	3.00
5020	5.00	2.20
6020	6.00	2.00
6028	6.00	2.80
6045	6.00	4.50
8040	8.00	4.20

(3) Design Code

(4) Inductance: 4R7 for 4.7uH ; 100 for 10 uH;

(5) Inductance tolerance: M: ±20% N: ±30%.

● **Shape and Dimensions:** (Dimensions are in mm)

Fig1

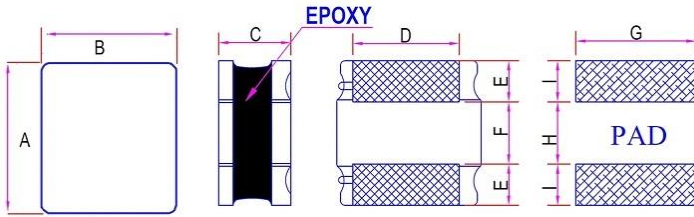

Fig2

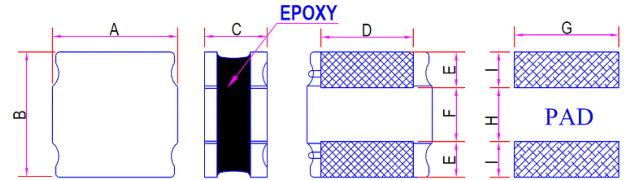

Fig3

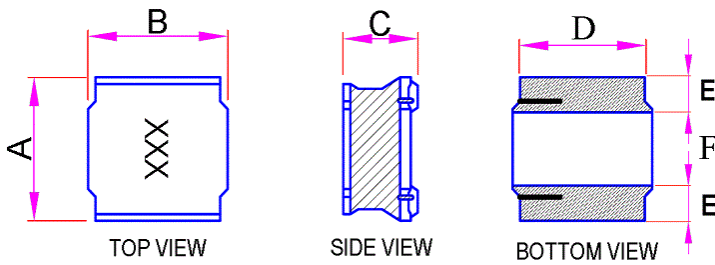
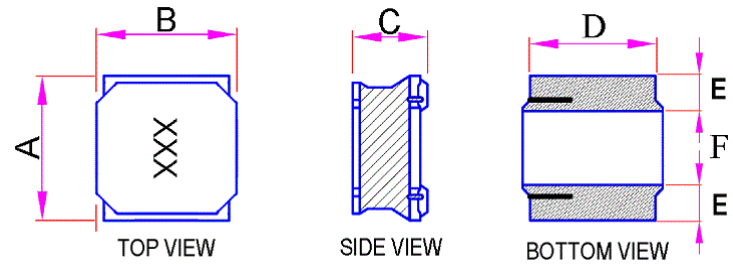

Fig4



ITEM	Shape	A	B	C	D	E	F
SNR2010K	Fig1	2.00+0.20	1.60+0.20	1.00 MAX	1.20	0.60	0.80
SNR2510K	Fig1	2.50+0.20	2.00+0.20	1.05 MAX	1.50	0.80	0.80
SNR2512K	Fig1	2.50+0.20	2.30 MAX	1.20 MAX	1.50	0.80	0.80
SNR3012K	Fig2	3.00+0.20	3.00+0.20	1.20 MAX	2.50	0.75	1.50
SNR3015K	Fig2	3.00+0.20	3.00+0.20	1.50 MAX	2.50	0.75	1.50
SNR4012K	Fig4	4.00+0.20	4.00+0.20	1.20 MAX	3.30	0.95	2.10
SNR4018K	Fig3	4.00+0.20	4.00+0.20	1.85 MAX	3.30	0.95	2.10
SNR4030K	Fig3	4.00+0.30	4.00+0.30	3.00 MAX	3.30	0.95	2.10
SNR5020K	Fig3	5.00+0.20	5.00+0.20	2.20 MAX	4.00	1.25	2.50
SNR5040K	Fig3	5.00+0.20	5.00+0.20	4.00 MAX	4.00	1.25	2.50
SNR6020K	Fig3	6.00+0.30	6.00+0.30	2.00 MAX	4.90	1.55	2.90
SNR6028K	Fig3	6.00+0.30	6.00+0.30	2.80 MAX	4.90	1.70	2.90
SNR6045K	Fig3	6.00+0.30	6.00+0.30	4.50 MAX	4.90	1.55	2.90
SNR8040K	Fig3	8.00+0.30	8.00+0.30	4.20 MAX	6.30	2.20	4.00

● SNR2010K-Series (Electrical specifications at 25°C)

Part No.	Inductance (uH)	Tolerance (+-%)	DCR(mΩ)		Isat(A) *1		Irms(A) *2		Test Condition
			Max	Typ	Max	Typ	Max	Typ	
SNR2010K-R24M	0.24	20	40	33	3.70	4.10	2.80	3.10	1MHz/1.0V
SNR2010K-R33M	0.33	20	48	41	3.00	3.70	2.40	2.90	
SNR2010K-R47M	0.47	20	60	50	2.30	2.85	2.30	2.60	
SNR2010K-R68M	0.68	20	76	63	1.95	2.45	2.00	2.20	
SNR2010K-1R0M	1.00	20	114	96	1.65	1.85	1.45	1.60	
SNR2010K-1R5M	1.50	20	174	145	1.35	1.65	1.10	1.20	
SNR2010K-2R2M	2.20	20	265	215	1.20	1.45	1.05	1.15	
SNR2010K-3R3M	3.30	20	345	290	1.00	1.20	0.85	0.95	
SNR2010K-4R7M	4.70	20	480	400	0.75	0.90	0.70	0.80	
SNR2010K-6R8M	6.80	20	800	610	0.70	0.85	0.55	0.60	
SNR2010K-8R2M	8.20	20	940	730	0.68	0.78	0.53	0.60	
SNR2010K-100M	10.0	20	1000	800	0.65	0.70	0.50	0.60	
SNR2010K-220M	22.0	20	1700	1400	0.32	0.38	0.32	0.36	

*1: Isat: The current when the inductance becomes 35% lower than its initial value (Ta=25°C).

*2: Irms: The current when temperature of coil increase up to max. ΔT=40°C (Ta=25°C).

Test Equipment:

L: measured on Agilent 4284A LCR meter or equivalent

DCR: measured on Chroma 16502 micro-OHM meter or equivalent

Isat&Irms: measured on Agilent 4284A LCR meter with 42841A Current Source or equivalent.

Notice:

The part temperature (ambient + temp. rise) should not exceed 125°C under worst case operating conditions. Circuit design, component placement, PCB trace size and thickness, airflow and other cooling provisions all affect the part temperature. Part temperature should be verified in the end application.

● SNR2510K-Series (Electrical specifications at 25°C)

Part No.	Inductance (uH)	Tolerance (+-%)	DCR(Ω)		Isat(A) *1		Irms(A) *2		Test Condition
			Max	Typ	Max	Typ	Max	Typ	
SNR2510K-R24M	0.24	20	0.034	0.026	3.60	4.40	2.75	3.00	1MHz/1.0V
SNR2510K-R33M	0.33	20	0.043	0.033	3.60	4.30	2.45	2.70	
SNR2510K-R47M	0.47	20	0.044	0.033	2.80	3.20	2.40	2.60	
SNR2510K-R68M	0.68	20	0.062	0.051	2.75	3.10	2.10	2.35	
SNR2510K-1R0M	1.00	20	0.080	0.066	2.05	2.50	1.85	2.05	
SNR2510K-1R5M	1.50	20	0.108	0.085	1.70	2.05	1.55	1.70	
SNR2510K-2R2M	2.20	20	0.139	0.115	1.50	1.75	1.35	1.50	
SNR2510K-3R3M	3.30	20	0.228	0.170	1.10	1.35	1.05	1.20	
SNR2510K-4R7M	4.70	20	0.330	0.280	1.00	1.15	0.90	1.00	
SNR2510K-6R8M	6.80	20	0.480	0.400	0.80	0.95	0.72	0.80	
SNR2510K-100M	10.0	20	0.600	0.500	0.65	0.75	0.67	0.74	
SNR2510K-150M	15.0	20	0.950	0.780	0.50	0.60	0.45	0.50	

*1: Isat: The current when the inductance becomes 35% lower than its initial value (Ta=25°C).

*2: Irms: The current when temperature of coil increase up to max. ΔT=40°C (Ta=25°C).

Test Equipment:

L: measured on Agilent 4284A LCR meter or equivalent

DCR: measured on Chroma 16502 micro-OHM meter or equivalent

Isat&Irms: measured on Agilent 4284A LCR meter with 42841A Current Source or equivalent.

Notice:

The part temperature (ambient + temp. rise) should not exceed 125°C under worst case operating conditions. Circuit design, component placement, PCB trace size and thickness, airflow and other cooling provisions all affect the part temperature. Part temperature should be verified in the end application.

● SNR2512K-Series (Electrical specifications at 25°C)

Part No.	Inductance (uH)	Tolerance (+-%)	DCR(Ω)		Isat(A) *1		Irms(A) *2		Test Condition
			Max	Typ	Max	Typ	Max	Typ	
SNR2512K-R24M	0.24	20	0.023	0.019	4.10	4.80	4.10	4.50	1MHz/1.0V
SNR2512K-R33M	0.33	20	0.031	0.026	4.00	4.70	3.35	3.70	
SNR2512K-R47M	0.47	20	0.036	0.031	3.80	4.50	3.00	3.30	
SNR2512K-R68M	0.68	20	0.042	0.033	3.00	3.30	2.30	2.50	
SNR2512K-1R0M	1.00	20	0.060	0.050	2.25	2.50	2.30	2.60	
SNR2512K-1R2M	1.20	20	0.078	0.065	2.20	2.50	2.00	2.20	
SNR2512K-1R5M	1.50	20	0.090	0.075	2.00	2.35	1.80	2.00	
SNR2512K-1R8M	1.80	20	0.108	0.093	1.95	2.20	1.75	1.90	
SNR2512K-2R2M	2.20	20	0.108	0.093	1.80	1.90	1.75	1.90	
SNR2512K-3R3M	3.30	20	0.156	0.130	1.20	1.35	1.40	1.50	
SNR2512K-4R7M	4.70	20	0.228	0.190	1.10	1.20	1.10	1.20	
SNR2512K-6R8M	6.80	20	0.360	0.300	0.90	1.10	0.95	1.05	
SNR2512K-100M	10.0	20	0.522	0.435	0.70	0.85	0.78	0.85	
SNR2512K-220M	22.0	20	1.290	1.000	0.45	0.55	0.48	.55	

*1: Isat: The current when the inductance becomes 35% lower than its initial value (Ta=25°C).

*2: Irms: The current when temperature of coil increase up to max. ΔT=40°C (Ta=25°C).

Test Equipment:

L: measured on Agilent 4284A LCR meter or equivalent

DCR: measured on Chroma 16502 micro-OHM meter or equivalent

Isat&Irms: measured on Agilent 4284A LCR meter with 42841A Current Source or equivalent.

Notice:

The part temperature (ambient + temp. rise) should not exceed 125°C under worst case operating conditions. Circuit design, component placement, PCB trace size and thickness, airflow and other cooling provisions all affect the part temperature. Part temperature should be verified in the end application.

● SNR3012K-Series (Electrical specifications at 25°C)

Part No.	Inductance (uH)	Tolerance (+-%)	DCR(mΩ) +30%	Isat(A) *1 Max	Irms(A) *2 Max	Test Condition
SNR3012K-R33N	0.33	30	21	3.00	2.90	100KHz/0.25V
SNR3012K-R47N	0.47	30	33	2.20	2.20	
SNR3012K-R82N	0.82	30	40	2.05	2.10	
SNR3012K-1R0N	1.00	30	48	1.90	2.00	
SNR3012K-1R5N	1.50	30	55	1.62	1.85	
SNR3012K-2R2M	2.20	20	75	1.20	1.55	
SNR3012K-3R3M	3.30	20	100	1.05	1.35	
SNR3012K-4R7M	4.70	20	120	0.90	1.25	
SNR3012K-5R6M	5.60	20	160	0.80	1.10	
SNR3012K-6R8M	6.80	20	190	0.75	1.00	
SNR3012K-100M	10.0	20	265	0.60	0.89	
SNR3012K-150M	15.0	20	430	0.45	0.72	
SNR3012K-220M	22.0	20	630	0.42	0.55	

*1: Isat: The current when the inductance becomes 35% lower than its initial value (Ta=25°C).

*2: Irms: The current when temperature of coil increase up to max. ΔT=40°C (Ta=25°C).

Test Equipment:

L: measured on Agilent 4284A LCR meter or equivalent

DCR: measured on Chroma 16502 micro-OHM meter or equivalent

Isat&Irms: measured on Agilent 4284A LCR meter with 42841A Current Source or equivalent.

Notice:

The part temperature (ambient + temp. rise) should not exceed 125°C under worst case operating conditions. Circuit design, component placement, PCB trace size and thickness, airflow and other cooling provisions all affect the part temperature. Part temperature should be verified in the end application.

● SNR3015K-Series (Electrical specifications at 25°C)

Part No.	Inductance (uH)	Tolerance (+-%)	DCR(mΩ) +30%	Isat(A) *1		Irms(A) *2	Test Condition
				Max	Max		
SNR3015K-R30N	0.30	30	15	4.60	3.50	1MHz/0.25V	
SNR3015K-R47N	0.47	30	20	4.00	3.50		
SNR3015K-1R0N	1.00	30	30	2.32	2.10		
SNR3015K-1R5N	1.50	30	50	2.00	1.70		
SNR3015K-1R8N	1.80	30	55	1.75	1.65		
SNR3015K-2R2N	2.20	30	60	1.60	1.60	100KHz/0.25V	
SNR3015K-2R7N	2.70	30	70	1.52	1.50		
SNR3015K-3R3M	3.30	20	80	1.32	1.36		
SNR3015K-4R7M	4.70	20	125	1.10	1.09		
SNR3015K-5R6M	5.60	20	170	1.05	1.00		
SNR3015K-6R8M	6.80	20	200	0.85	0.85		
SNR3015K-100M	10.0	20	250	0.72	0.77		
SNR3015K-150M	15.0	20	350	0.66	0.65		
SNR3015K-180M	18.0	20	430	0.56	0.59		
SNR3015K-220M	22.0	20	460	0.52	0.57		
SNR3015K-330M	33.0	20	780	0.44	0.42		
SNR3015K-470M	47	20	1200	0.35	0.32		

*1: Isat: The current when the inductance becomes 35% lower than its initial value (Ta=25°C).

*2: Irms: The current when temperature of coil increase up to max. ΔT=40°C (Ta=25°C).

Test Equipment:

L: measured on Agilent 4284A LCR meter or equivalent

DCR: measured on Chroma 16502 micro-OHM meter or equivalent

Isat&Irms: measured on Agilent 4284A LCR meter with 42841A Current Source or equivalent.

Notice:

The part temperature (ambient + temp. rise) should not exceed 125°C under worst case operating conditions. Circuit design, component placement, PCB trace size and thickness, airflow and other cooling provisions all affect the part temperature. Part temperature should be verified in the end application.

● SNR4012K-Series (Electrical specifications at 25°C)

Part No.	Inductance (uH)	Test Condition	DCR(Ω)		Isat(A) *1		Irms(A) *2		Marking
			Max	Typ	Max	Typ	Max	Typ	
SNR4012K-1R0N	1.0+-30%	100KHz/1V	0.055	0.042	2.80	3.00	2.00	2.30	1R0
SNR4012K-1R5N	1.5+-30%		0.065	0.051	2.20	2.35	1.80	2.00	1R5
SNR4012K-2R2M	2.2+-20%		0.100	0.075	1.76	2.00	1.32	1.90	2R2
SNR4012K-3R3M	3.3+-20%		0.100	0.075	1.35	1.65	1.32	1.90	3R3
SNR4012K-4R7M	4.7+-20%		0.163	0.125	1.15	1.50	1.00	1.40	4R7
SNR4012K-5R6M	5.6+-20%		0.228	0.175	1.15	1.30	0.85	1.10	6R8
SNR4012K-100M	10+-20%		0.234	0.180	0.85	0.95	0.80	1.00	100
SNR4012K-150M	15+-20%		0.400	0.310	0.68	0.80	0.65	0.80	150
SNR4012K-180M	18+-20%		0.550	0.430	0.60	0.75	0.55	0.80	180
SNR4012K-220M	22+-20%		0.690	0.530	0.50	0.70	0.49	0.75	220
SNR4012K-330M	33+-20%		1.000	0.780	0.50	0.60	0.42	0.52	330
SNR4012K-470M	47+-20%		1.430	1.100	0.35	0.45	0.37	0.50	470

*1: Isat: The current when the inductance becomes 35% lower than its initial value (Ta=25°C).

*2: I rms: The current when temperature of coil increase up to max. ΔT=40°C (Ta=25°C).

Test Equipment:

L: measured on Agilent 4284A LCR meter or equivalent

DCR: measured on Chroma 16502 micro-OHM meter or equivalent

Isat&I rms: measured on Agilent 4284A LCR meter with 42841A Current Source or equivalent.

Notice:

The part temperature (ambient + temp. rise) should not exceed 125°C under worst case operating conditions. Circuit design, component placement, PCB trace size and thickness, airflow and other cooling provisions all affect the part temperature. Part temperature should be verified in the end application.

● SNR4018K-Series (Electrical specifications at 25°C)

Part No.	Inductance (uH)	Tolerance (+-%)	DCR(mΩ) (+-30%)	Isat*1 (A)	Irms*2 (A)	Test Condition	Marking
SNR4018K-R56N	0.56	30	18	6.50	3.50	100KHz/0.25V	R56
SNR4018K-1R0N	1.00	30	23	4.50	2.50		1R0
SNR4018K-1R2N	1.20	30	28	4.3	2.40		1R2
SNR4018K-1R5N	1.50	30	33	3.35	2.34		1R5
SNR4018K-2R2M	2.20	20	44	2.70	2.00		2R2
SNR4018K-3R3M	3.30	20	70	3.45	1.90		3R3
SNR4018K-4R7M	4.70	20	90	1.70	1.70		4R7
SNR4018K-5R6M	5.60	20	103	1.60	1.50		5R6
SNR4018K-6R8M	6.80	20	124	1.45	1.30		6R8
SNR4018K-8R2M	8.20	20	180	1.40	1.15		8R2
SNR4018K-100M	10.0	20	200	1.30	1.10		100
SNR4018K-120M	12.0	20	230	1.15	0.95		120
SNR4018K-150M	15.0	20	268	0.94	0.92		150
SNR4018K-220M	22.0	20	390	0.80	0.80		220
SNR4018K-330M	33.0	20	560	0.65	0.60	330	
SNR4018K-470M	47.0	20	850	0.57	0.50	470	

*1: Isat: The current when the inductance becomes 35% lower than its initial value (Ta=25°C).

*2: Irms: The current when temperature of coil increase up to max. ΔT=40°C (Ta=25°C).

Test Equipment:

L: measured on Agilent 4284A LCR meter or equivalent

DCR: measured on Chroma 16502 micro-OHM meter or equivalent

Isat&Irms: measured on Agilent 4284A LCR meter with 42841A Current Source or equivalent.

Notice:

The part temperature (ambient + temp. rise) should not exceed 125°C under worst case operating conditions. Circuit design, component placement, PCB trace size and thickness, airflow and other cooling provisions all affect the part temperature. Part temperature should be verified in the end application.

● SNR4030K-Series (Electrical specifications at 25°C)

Part No.	Inductance (uH)	Tolerance (+-%)	DCR (mΩ) (+30%)	Isat*1 (A)	Irms*2 (A)	Test Condition	Marking
SNR4030K-R47N	0.47	30	11	7.50	3.50	100KHz/0.25V	R47
SNR4030K-1R0N	1.00	30	15	5.90	3.40		1R0
SNR4030K-1R5N	1.50	30	25	4.85	3.30		1R5
SNR4030K-1R8N	1.80	30	30	4.25	3.20		1R8
SNR4030K-2R2M	2.20	20	35	4.10	2.95		2R2
SNR4030K-3R3M	3.30	20	40	3.30	2.40		3R3
SNR4030K-3R9M	3.90	20	57	3.00	2.10		3R9
SNR4030K-4R7M	4.70	20	60	2.90	2.00		4R7
SNR4030K-5R6M	5.60	20	70	2.75	1.95		5R6
SNR4030K-6R8M	6.80	20	75	2.60	1.70		6R8
SNR4030K-7R5M	7.50	20	90	2.20	1.65		7R5
SNR4030K-8R2M	8.20	20	100	2.10	1.60		8R2
SNR4030K-100M	10.0	20	115	1.95	1.50		100
SNR4030K-120M	12.0	20	140	1.70	1.35		120
SNR4030K-150M	15.0	20	190	1.65	1.15		150
SNR4030K-180M	18.0	20	215	1.40	1.10		180
SNR4030K-220M	20.0	20	225	1.30	1.00		220
SNR4030K-330M	33.0	20	330	1.10	0.84		330
SNR4030K-470M	47.0	20	500	0.90	0.70		470
SNR4030K-560M	56.0	20	560	0.85	0.64		560
SNR4030K-680M	68.0	20	750	0.75	0.55	680	
SNR4030K-820M	82.0	20	950	0.68	0.50	820	
SNR4030K-101M	100	20	1150	0.60	0.45	101	
SNR4030K-151M	150	20	2350	0.50	0.35	151	

*1: Isat: The current when the inductance becomes 35% lower than its initial value (Ta=25°C).

*2: I rms: The current when temperature of coil increase up to max. ΔT=40°C (Ta=25°C).

Test Equipment:

L: measured on Agilent 4284A LCR meter or equivalent

DCR: measured on Chroma 16502 micro-OHM meter or equivalent

Isat&I rms: measured on Agilent 4284A LCR meter with 42841A Current Source or equivalent.

Notice:

The part temperature (ambient + temp. rise) should not exceed 125°C under worst case operating conditions. Circuit design, component placement, PCB trace size and thickness, airflow and other cooling provisions all affect the part temperature. Part temperature should be verified in the end application.

● SNR5020K-Series (Electrical specifications at 25°C)

Part No.	Inductance (uH)	Tolerance (+-%)	DCR (mΩ) (+30%)	Isat*1 (A)	Irms*2 (A)	Test Condition	Marking
SNR5020K-R22N	0.22	30	11	6.00	5.00	100KHz/0.25V	R22
SNR5020K-R24N	0.24	30	11	6.00	5.00		R24
SNR5020K-R47N	0.47	30	15	4.85	3.95		R47
SNR5020K-1R0N	1.00	30	20	4.33	3.70		1R0
SNR5020K-1R2N	1.20	30	25	4.20	3.50		1R2
SNR5020K-1R5N	1.50	30	26	4.10	3.20		1R5
SNR5020K-1R8N	1.80	30	30	4.00	3.00		1R8
SNR5020K-2R2N	2.20	30	38	3.85	2.90		2R2
SNR5020K-2R7N	2.70	30	45	3.50	2.40		2R7
SNR5020K-3R3N	3.30	30	46	3.25	2.40		3R3
SNR5020K-3R9N	3.90	30	50	2.90	2.15		3R9
SNR5020K-4R7M	4.70	20	65	2.40	2.05		4R7
SNR5020K-5R6M	5.60	20	72	2.30	1.85		5R6
SNR5020K-6R8M	6.80	20	92	2.10	1.70		6R8
SNR5020K-8R2M	8.20	20	100	1.90	1.60		8R2
SNR5020K-100M	10.0	20	125	1.80	1.50		100
SNR5020K-150M	15.0	20	180	1.44	1.25		150
SNR5020K-220M	22.0	20	250	1.18	1.05		220
SNR5020K-330M	33.0	20	370	0.97	0.83		330
SNR5020K-470M	47.0	20	560	0.81	0.70		470
SNR5020K-680M	68.0	20	850	0.70	0.53	680	

*1: Isat: The current when the inductance becomes 35% lower than its initial value (Ta=25°C).

*2: Irms: The current when temperature of coil increase up to max. ΔT=40°C (Ta=25°C).

Test Equipment:

L: measured on Agilent 4284A LCR meter or equivalent

DCR: measured on Chroma 16502 micro-OHM meter or equivalent

Isat&Irms: measured on Agilent 4284A LCR meter with 42841A Current Source or equivalent.

Notice:

The part temperature (ambient + temp. rise) should not exceed 125°C under worst case operating conditions. Circuit design, component placement, PCB trace size and thickness, airflow and other cooling provisions all affect the part temperature. Part temperature should be verified in the end application.

● SNR5040K-Series (Electrical specifications at 25°C)

Part No.	Inductance (uH)	Tolerance (+-%)	DCR (mΩ) (+-30%)	Isat*1 (A)	Irms*2 (A)	Test Condition	Marking
SNR5040K-1R0N	1.00	30	13	7.35	4.90	100KHz/0.25V	1R0
SNR5040K-1R5N	1.50	30	15	6.30	4.30		1R5
SNR5040K-1R8N	1.80	30	18	6.10	3.90		1R8
SNR5040K-2R2N	2.20	30	19	4.90	3.80		2R2
SNR5040K-2R7N	2.70	30	22	4.30	3.60		2R7
SNR5040K-3R3N	3.30	30	24	3.95	3.40		3R3
SNR5040K-3R9N	3.90	30	27	3.55	3.20		3R9
SNR5040K-4R7M	4.70	20	30	3.50	3.00		4R7
SNR5040K-5R6M	5.60	20	33	3.20	2.80		5R6
SNR5040K-6R8M	6.80	20	43	2.90	2.50		6R8
SNR5040K-8R2M	8.20	20	55	3.00	2.30		8R2
SNR5040K-100M	10.0	20	64	2.35	2.10		100
SNR5040K-150M	15.0	20	86	2.00	2.00		150
SNR5040K-220M	22.0	20	129	1.60	1.50		220
SNR5040K-270M	27.0	20	165	1.50	1.30		270
SNR5040K-330M	33.0	20	188	1.30	1.20		330
SNR5040K-390M	39.0	20	225	1.20	1.10		390
SNR5040K-470M	47.0	20	270	1.10	1.00		470
SNR5040K-680M	68.0	20	400	0.90	0.80		680
SNR5040K-101M	100	20	560	0.75	0.70		101

*1: Isat: The current when the inductance becomes 35% lower than its initial value (Ta=25°C).

*2: Iirms: The current when temperature of coil increase up to max. ΔT=40°C (Ta=25°C).

Test Equipment:

L: measured on Agilent 4284A LCR meter or equivalent

DCR: measured on Chroma 16502 micro-OHM meter or equivalent

Isat&Iirms: measured on Agilent 4284A LCR meter with 42841A Current Source or equivalent.

Notice:

The part temperature (ambient + temp. rise) should not exceed 125°C under worst case operating conditions. Circuit design, component placement, PCB trace size and thickness, airflow and other cooling provisions all affect the part temperature. Part temperature should be verified in the end application

● SNR6020K-Series (Electrical specifications at 25°C)

Part No.	Inductance (uH)	Tolerance (+-%)	DCR (mΩ) (+30%)	Isat*1 (A)	Irms*2 (A)	Test Condition	Marking
SNR6020K-R68N	0.68	30	15	7.50	3.80	100KHz/0.25V	R68
SNR6020K-1R0N	1.00	30	20	4.80	3.50		1R0
SNR6020K-1R2N	1.20	30	20	4.30	3.50		1R2
SNR6020K-1R5N	1.50	30	25	4.30	3.20		1R5
SNR6020K-2R2N	2.20	30	35	3.75	2.75		2R2
SNR6020K-3R3N	3.30	30	45	3.15	2.60		3R3
SNR6020K-4R7N	4.70	30	58	3.00	2.00		4R7
SNR6020K-5R6M	5.60	20	70	2.40	1.90		5R6
SNR6020K-6R8M	6.80	20	85	2.20	1.80		6R8
SNR6020K-100M	10.0	20	120	1.75	1.40		100
SNR6020K-150M	15.0	20	160	1.50	1.20		150
SNR6020K-220M	22.0	20	240	1.25	1.00		220
SNR6020K-270M	27.0	20	350	1.15	0.95		270
SNR6020K-330M	33.0	20	400	1.10	0.90		330
SNR6020K-470M	47.0	20	500	1.00	0.80		470

*1: Isat: The current when the inductance becomes 35% lower than its initial value (Ta=25°C).

*2: Iirms: The current when temperature of coil increase up to max. ΔT=40°C (Ta=25°C).

Test Equipment:

L: measured on Agilent 4284A LCR meter or equivalent

DCR: measured on Chroma 16502 micro-OHM meter or equivalent

Isat&Iirms: measured on Agilent 4284A LCR meter with 42841A Current Source or equivalent.

Notice:

The part temperature (ambient + temp. rise) should not exceed 125°C under worst case operating conditions.

Circuit design, component placement, PCB trace size and thickness, airflow and other cooling provisions all affect the part temperature. Part temperature should be verified in the end application

● SNR6028K-Series (Electrical specifications at 25°C)

Part No.	Inductance (uH)	Tolerance (+-%)	DCR (mΩ) (+30%)	Isat*1 (A)	Irms*2 (A)	Test Condition	Marking
SNR6028K-1R0N	1.00	30	12	6.70	4.60	100KHz/0.25V	1R0
SNR6028K-1R5N	1.50	30	16	6.00	4.30		1R5
SNR6028K-2R2N	2.20	30	20	5.10	3.75		2R2
SNR6028K-3R3N	3.30	30	25	3.63	3.40		3R3
SNR6028K-4R7N	4.70	30	33	3.00	3.00		4R7
SNR6028K-5R6N	5.60	30	45	2.80	2.45		5R6
SNR6028K-6R8M	6.80	20	56	2.60	2.40		6R8
SNR6028K-8R2M	8.20	20	68	2.40	2.25		8R2
SNR6028K-100M	10.0	20	78	2.05	1.90		100
SNR6028K-120M	12.0	20	88	1.80	1.70		120
SNR6028K-150M	15.0	20	125	1.75	1.50		150
SNR6028K-180M	18.0	20	130	1.55	1.45		180
SNR6028K-220M	22.0	20	140	1.45	1.40		220
SNR6028K-270M	27.0	20	180	1.40	1.30		270
SNR6028K-330M	33.0	20	220	1.35	1.10		330
SNR6028K-390M	39.0	20	225	1.25	1.10		390
SNR6028K-470M	47.0	20	280	1.15	1.05		470
SNR6028K-680M	68	20	420	0.95	0.85		680
SNR6028K-820M	82	20	550	0.80	0.70		820
SNR6028K-101M	100	20	670	0.65	0.60		101
SNR6028K-121M	120	20	820	0.62	0.58	121	

*1: Isat: The current when the inductance becomes 35% lower than its initial value (Ta=25°C).

*2: Irms: The current when temperature of coil increase up to max. ΔT=40°C (Ta=25°C).

Test Equipment:

L: measured on Agilent 4284A LCR meter or equivalent

DCR: measured on Chroma 16502 micro-OHM meter or equivalent

Isat&Irms: measured on Agilent 4284A LCR meter with 42841A Current Source or equivalent.

Notice:

The part temperature (ambient + temp. rise) should not exceed 125°C under worst case operating conditions. Circuit design, component placement, PCB trace size and thickness, airflow and other cooling provisions all affect the part temperature. Part temperature should be verified in the end application

● SNR6045K-Series (Electrical specifications at 25°C)

Part No.	Inductance (uH)	Tolerance (+-%)	DCR (mΩ) (+-30%)	Isat*1 (A)	Irms*2 (A)	Test Condition	Marking
SNR6045K-1R0N	1.00	30	10	9.00	5.10	100KHz/0.25V	1R0
SNR6045K-1R5N	1.50	30	12	7.50	4.75		1R5
SNR6045K-1R8N	1.80	30	13	7.50	4.6		1R8
SNR6045K-2R2N	2.20	30	13	6.50	4.60		2R2
SNR6045K-3R3N	3.30	30	20	5.30	3.20		3R3
SNR6045K-3R9N	3.90	30	20	4.90	3.20		3R9
SNR6045K-4R7N	4.70	30	24	4.50	3.00		4R7
SNR6045K-5R6N	5.60	30	21	3.70	2.80		5R6
SNR6045K-6R8M	6.80	20	33	3.30	2.70		6R8
SNR6045K-8R2M	8.20	20	45	3.20	2.60		8R2
SNR6045K-100M	10.0	20	52	3.00	2.50		100
SNR6045K-120M	12.0	20	58	2.80	2.20		120
SNR6045K-150M	15.0	20	77	2.50	1.90		150
SNR6045K-220M	22.0	20	115	2.00	1.50		220
SNR6045K-270M	27.0	20	120	1.90	1.48		270
SNR6045K-330M	33.0	20	150	1.60	1.45		330
SNR6045K-390M	39.0	20	180	1.50	1.25		390
SNR6045K-470M	47.0	20	220	1.40	1.20		470
SNR6045K-560M	56.0	20	260	1.30	1.10		560
SNR6045K-680M	68.0	20	290	1.20	0.90		680
SNR6045K-820M	82.0	20	355	1.10	0.85	820	
SNR6045K-101M	100	20	430	1.00	0.80	101	



SNR6045K-121M	120	20	530	0.85	0.75		121
SNR6045K-151M	150	20	760	0.80	0.70		151
SNR6045K-181M	180	20	845	0.75	0.65		181
SNR6045K-221M	220	20	890	0.63	0.55		221
SNR6045K-331M	330	20	1410	0.51	0.48		331

*1: Isat: The current when the inductance becomes 35% lower than its initial value (Ta=25°C).

*2: Irms: The current when temperature of coil increase up to max. ΔT=40°C (Ta=25°C).

Test Equipment:

L: measured on Agilent 4284A LCR meter or equivalent

DCR: measured on Chroma 16502 micro-OHM meter or equivalent

Isat&Irms: measured on Agilent 4284A LCR meter with 42841A Current Source or equivalent.

Notice:

The part temperature (ambient + temp. rise) should not exceed 125°C under worst case operating conditions.

Circuit design, component placement, PCB trace size and thickness, airflow and other cooling provisions all affect the part temperature. Part temperature should be verified in the end application

● SNR8040K-Series (Electrical specifications at 25°C)

Part No.	Inductance (uH)	Tolerance (+-%)	DCR (mΩ) (+-30%)	Isat*1 (A)	Irms*2 (A)	Test Condition	Marking
SNR8040K-R56N	0.56	30	5	11.5	7.60	1MHz/0.25V	R56
SNR8040K-1R0N	1.00	30	8	9.85	6.30		1R0
SNR8040K-1R5N	1.50	30	10	8.15	5.65		1R5
SNR8040K-2R2N	2.20	30	12	7.10	5.15		2R2
SNR8040K-3R3N	3.30	30	17	6.50	4.40		3R3
SNR8040K-4R7N	4.70	30	20	5.90	4.00		4R7
SNR8040K-5R6N	5.60	30	24	5.50	3.80		5R6
SNR8040K-6R8M	6.80	20	28	4.55	3.60		6R8
SNR8040K-8R2M	8.20	20	35	4.20	3.40		8R2
SNR8040K-100M	10.0	20	37	3.60	3.10		100
SNR8040K-150M	15.0	20	56	2.95	2.50	100KHz/0.25V	150
SNR8040K-220M	22.0	20	74	2.40	2.00		220
SNR8040K-270M	27.0	20	80	2.15	1.90		270
SNR8040K-330M	33.0	20	100	2.05	1.70		330
SNR8040K-470M	47.0	20	158	1.75	1.50		470
SNR8040K-560M	56.0	20	160	1.55	1.40		560
SNR8040K-680M	68.0	20	196	1.45	1.20		680
SNR8040K-101M	100	20	295	1.15	1.00		101
SNR8040K-151M	150	20	470	1.10	0.80		151
SNR8040K-171M	170	20	538	0.95	0.75		171
SNR8040K-181M	180	20	610	0.90	0.75	181	
SNR8040K-221M	220	20	660	0.85	0.70	221	
SNR8040K-331M	330	20	970	0.68	0.55	331	
SNR8040K-471M	470	20	1400	0.60	0.48	470	
SNR8040K-681M	680	20	1750	0.50	0.45	680	

*1: Isat: The current when the inductance becomes 35% lower than its initial value (Ta=25°C).

*2: Irms: The current when temperature of coil increase up to max. ΔT=40°C (Ta=25°C).

Test Equipment:

L: measured on Agilent 4284A LCR meter or equivalent

DCR: measured on Chroma 16502 micro-OHM meter or equivalent

Isat&Irms: measured on Agilent 4284A LCR meter with 42841A Current Source or equivalent.

Notice:

The part temperature (ambient + temp. rise) should not exceed 125°C under worst case operating conditions.

Circuit design, component placement, PCB trace size and thickness, airflow and other cooling provisions all affect the part temperature. Part temperature should be verified in the end application

● **Recommended Reflow Soldering Conditions: (SMT-TYP)**

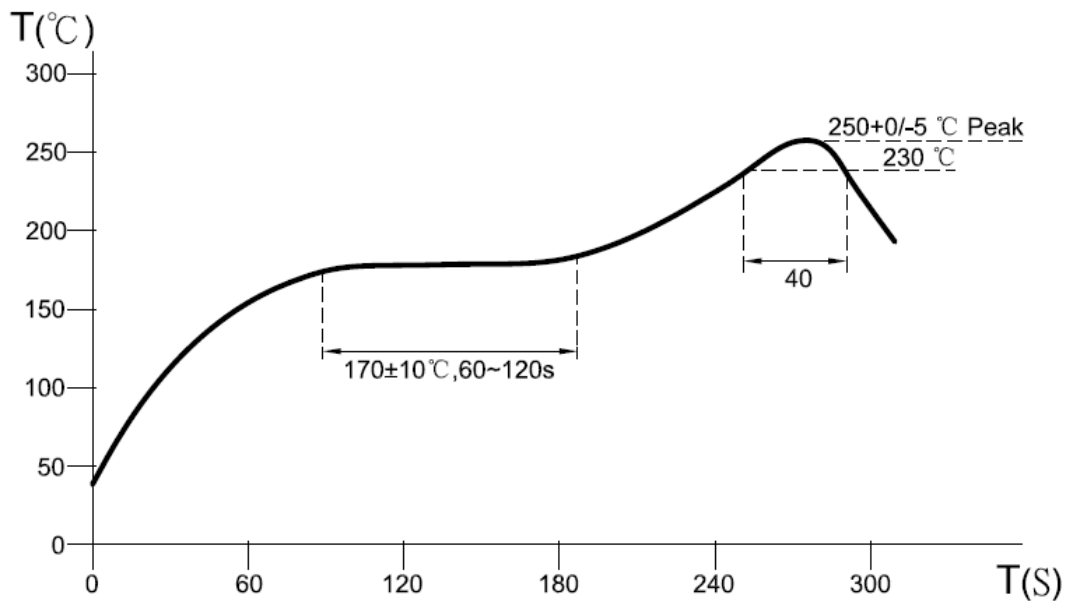

ADD:

The recommended reflow conditions as above graph, is set according to our soldering equipment due to various manufactures may have different reflow soldering equipment, products, process conditions, set methods .. And so on, when setting the reflow conditions, Please adjust and confirm according to users' environment/equipment.

Notice:

- a) Solder reflow temperature: $+250^{\circ}\text{C}$ Max. for 10 seconds Max
- b) To solder inductors by soldering iron is not recommended.
- c) Please contact us for details

● **Tape and Reel Specifications:** (Dimensions are in mm)

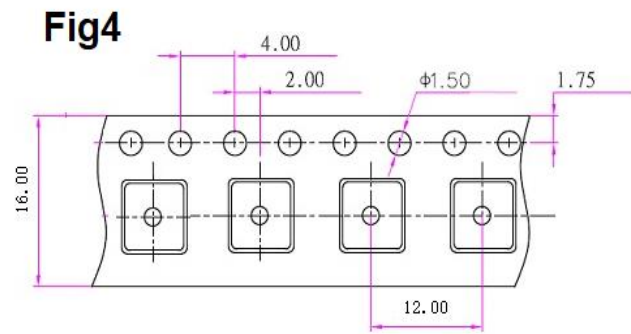
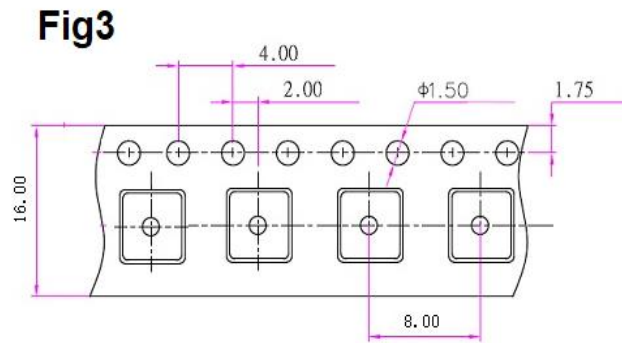
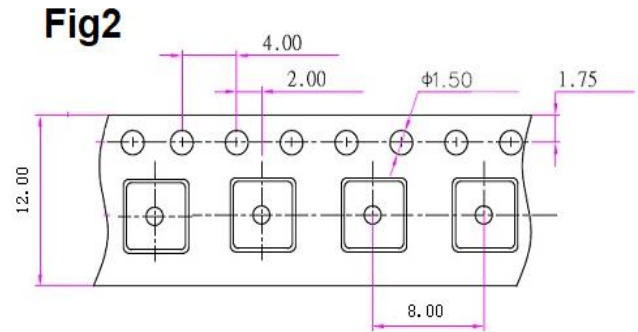
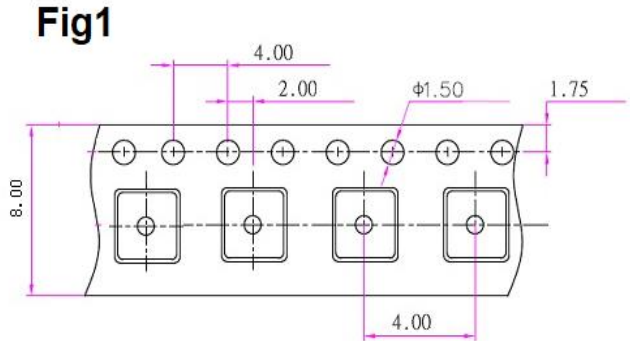

Part No.	Shape	REEL	PCS/REEL
SNR2010K	Fig1	7"	2000
SNR2510K	Fig1	7"	2000
SNR2512K	Fig1	7"	2000
SNR3012K	Fig1	7"	2000
SNR3015K	Fig1	7"	2000
SNR4012K	Fig2	13'	4500
SNR4018K	Fig2	13'	4500
SNR4030K	Fig2	13'	2000
SNR4030K	Fig2	13'	3000
SNR5020K	Fig2	13'	1500
SNR6020K	Fig2	13'	3000
SNR6028K	Fig2	13'	2000
SNR6045K	Fig2	13'	1500
SNR8040K	Fig4	13'	1000

Taping Specification: EIA -481 Compliant

● **Package Specifications:**

Fgi1



Fig2

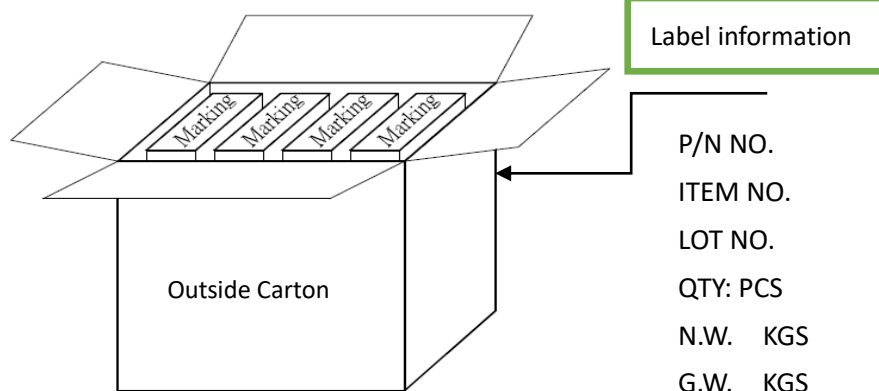
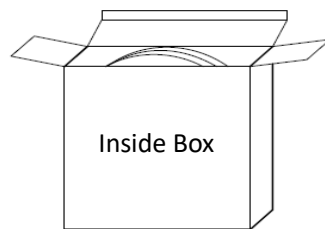

■ **Storage Conditions:**

- a) Temperature and humidity conditions: <35°C and < 35-65%.
- b) Recommendation: inductors should be used within 6 months from the time of delivery
- c) Packaging material should be kept away from where chlorine or sulfur exists.

■ **The Outside Carton and Inside Box Package quantity:**

Part No.	Shape	Inside Box(Pcs)	Outside Carton(Pcs)
SNR3015	Fgi1	8000	80000
SNR4018	Fgi2	15000	60000
SNR4030	Fgi2	10000	40000
SNR5040	Fgi2	7500	30000
SNR6045	Fgi2	4500	18000
SNR8040	Fgi2	3000	12000

X-ON Electronics

Largest Supplier of Electrical and Electronic Components

Click to view similar products for [Fixed Inductors](#) category:

Click to view products by [3L COILS](#) manufacturer:

Other Similar products are found below :

[CR32NP-151KC](#) [CR32NP-180KC](#) [CR32NP-181KC](#) [CR32NP-1R5MC](#) [CR32NP-390KC](#) [CR32NP-3R9MC](#) [CR32NP-680KC](#) [CR32NP-820KC](#) [CR32NP-8R2MC](#) [CR43NP-390KC](#) [CR43NP-560KC](#) [CR43NP-680KC](#) [CR54NP-181KC](#) [CR54NP-470LC](#) [CR54NP-820KC](#) [CR54NP-8R5MC](#) [70F224AI](#) [MGDQ4-00004-P](#) [MHL1ECTTP18NJ](#) [MHQ1005P10NJ](#) [MHQ1005P1N0S](#) [MHQ1005P2N4S](#) [MHQ1005P3N6S](#) [MHQ1005P5N1S](#) [MHQ1005P8N2J](#) [PE-51506NL](#) [PE-53601NL](#) [PE-53602NL](#) [PE-53630NL](#) [PE-53824SNLT](#) [PE-92100NL](#) [PG0434.801NLT](#) [PG0936.113NLT](#) [9220-20](#) [9310-16](#) [PM06-2N7](#) [PM06-39NJ](#) [A01TK](#) [1206CS-471XJ](#) [HC2LP-R47-R](#) [HC2-R47-R](#) [HC3-2R2-R](#) [HCF1305-3R3-R](#) [1206CS-151XG](#) [RCH664NP-140L](#) [RCH664NP-4R7M](#) [RCH8011NP-221L](#) [RCP1317NP-332L](#) [RCP1317NP-391L](#) [RCR1010NP-470M](#)