

3M™ BOARDMOUNT SOCKET, 1502 SERIES  
 2.00MM X 2.00MM STRAIGHT AND SURFACE MOUNT, PLATED THROUGH HOLE

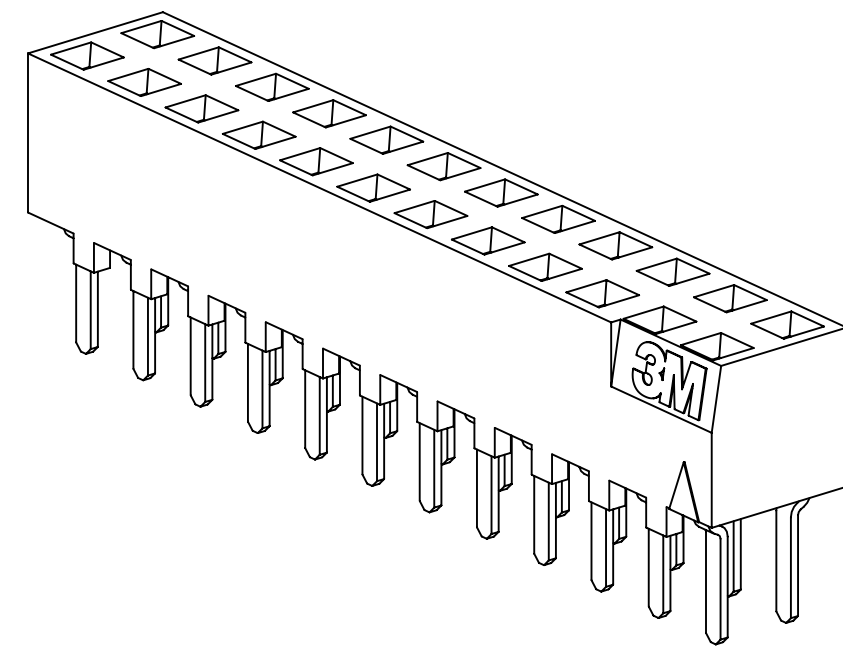

STRAIGHT  
VERSION

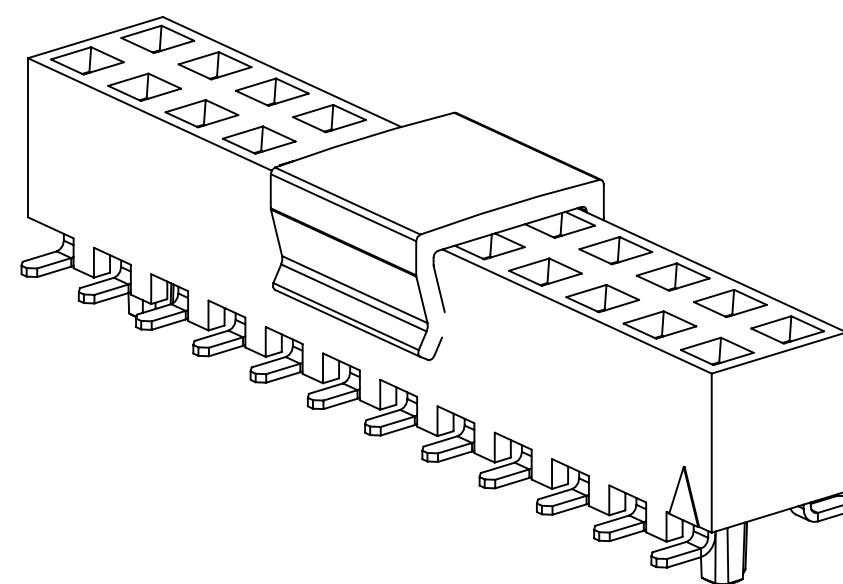

SURFACE MOUNT  
VERSION

2 PHYSICAL :

INSULATOR :  
 MATERIAL : HIGH TEMP THERMOPLASTIC  
 CONTACT :  
 MATERIAL : COPPER ALLOY  
 PLATING :  
 UNDER PLATING : 1.27-3.8µm ( 50-150µ" ) NICKEL-OVERALL  
 WIPING AREA : .76µm ( 30µ" ) GOLD  
 SOLDER TAILS : 5.1µm ( 200µ" ) MATTE TIN ( RIA E1 & C1 APPLY )  
 MARKING : ORIENTATION DELTA AND 3M LOGO ( EXCEPT SURFACE MOUNT )

2 ELECTRICAL :

CURRENT RATING : 1A  
 VOLTAGE RATING : 150V<sub>AC</sub> PER EIA-364-20  
 INSULATION RESISTANCE : >1 X 10<sup>9</sup> OHM AT 250V<sub>DC</sub>  
 WITHSTANDING VOLTAGE : 500V<sub>DC</sub> AT SEA LEVEL

2 ENVIRONMENTAL :

TEMPERATURE RATING : -55° C TO 105° C  
 PROCESS RATING : MAX. 260° C ( PER J-STD-020C )  
 MOISTURE SENSITIVITY LEVEL : 1 ( PER J-STD-020C )

- NOTES
1. REGULATORY INFORMATION:  
 ROHS COMPLIANT. SEE THE REGULATORY INFORMATION APPENDIX (RIA) IN THE "ROHS COMPLIANCE" SECTION OF WWW.3MCONNECTORS.COM FOR COMPLIANCE INFORMATION.
  2. IN THE EVENT OF CONFLICT BETWEEN THIS DATA AND THAT CONTAINED IN THE PRODUCT SPECIFICATION, THE PRODUCT SPECIFICATION TAKES PRECEDENT.
  3. TAPE & REEL INCLUDE VACUUM PICK-UP CAP FOR PICK 'N PLACE HANDLING EQUIPMENT.
  4. PARTS IN TRAY PACKAGING ARE SUPPLIED WITHOUT VACUUM CAP.
  5. POSITIONS PER ROW, SUBTRACT 1, MULTIPLY BY 2MM SPACING.
  6. OPTIONAL LOCATOR POSTS: POSITIONS PER ROW, MULTIPLY BY 2MM SPACING, THEN SUBTRACT 4MM. POSTS ARE ONLY AVAILABLE FOR POSITIONS 08 AND GREATER.

3M ELECTRONICS MATERIALS SOLUTIONS DIVISION  
 INTERCONNECT SOLUTIONS  
<http://www.3mconnectors.com>

3M IS A TRADEMARK OF 3M COMPANY.  
 FOR TECHNICAL, SALES OR ORDERING  
 INFORMATION CALL 800-225-5373

**UL**  
 UL FILE NO: E68080

DIMENSIONS: MM ( INCH )  
 ( INCH ) FOR REF. ONLY

DESIGN REFERENCE	NEXT ASSEMBLY	REV	ECO	ISSUE DATE AND DESCRIPTION	DRFT	CHKD
				SEP 03, 2015		
DO NOT SCALE DRAWING	SCALE 6/1	TOLERANCES EXCEPT AS NOTED		INCHES: .0 ± .1 .00 ± .01 .000 ± .005 .0000 ± .0002 MILLIMETERS: 0 ± .2 .0 ± .13 .000 ± .005		
THIRD ANGLE PROJECTION	INTERPRET PER ASME Y14.5 - 2009	MAX SURFACE ROUGHNESS		INCHES: .000 ± .005 MILLIMETERS: .000 ± .005		
DIVISION CODE EMSD		DIVISION 3M Center St. Paul, MN 55144		© 3M COPYRIGHT 2017 This document and the information it contains are 3M property and may not be reproduced or further distributed without 3M permission, or used or disclosed other than for 3M authorized purposes. All rights reserved.		
TITLE BOARDMOUNT SOCKET, 2MM X 2MM, STRAIGHT & SMT, PAC 20		CAGE NUMBER D78-5100-0519-8		REV. K		
MODEL 1502		DET. I S T S		YES X NO SHT 1 OF 4		

78-5100-0519-8  
 DRAWING NUMBER  
 K  
 REVISION  
 12/7/2017  
 Standard Time  
 Offset

3M™ BOARDMOUNT SOCKET, 1502 SERIES  
 2.00MM X 2.00MM STRAIGHT AND SURFACE MOUNT, PLATED THROUGH HOLE

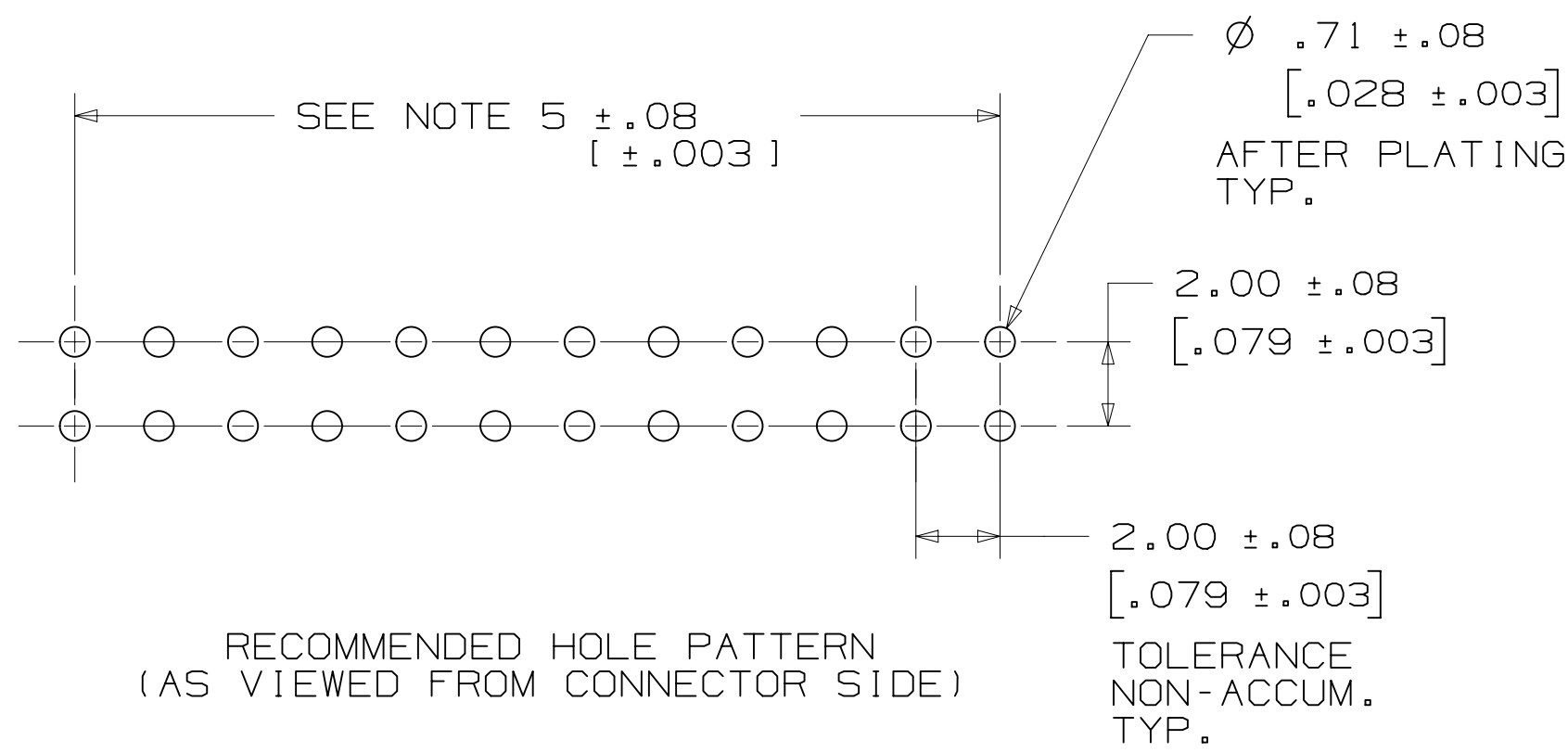
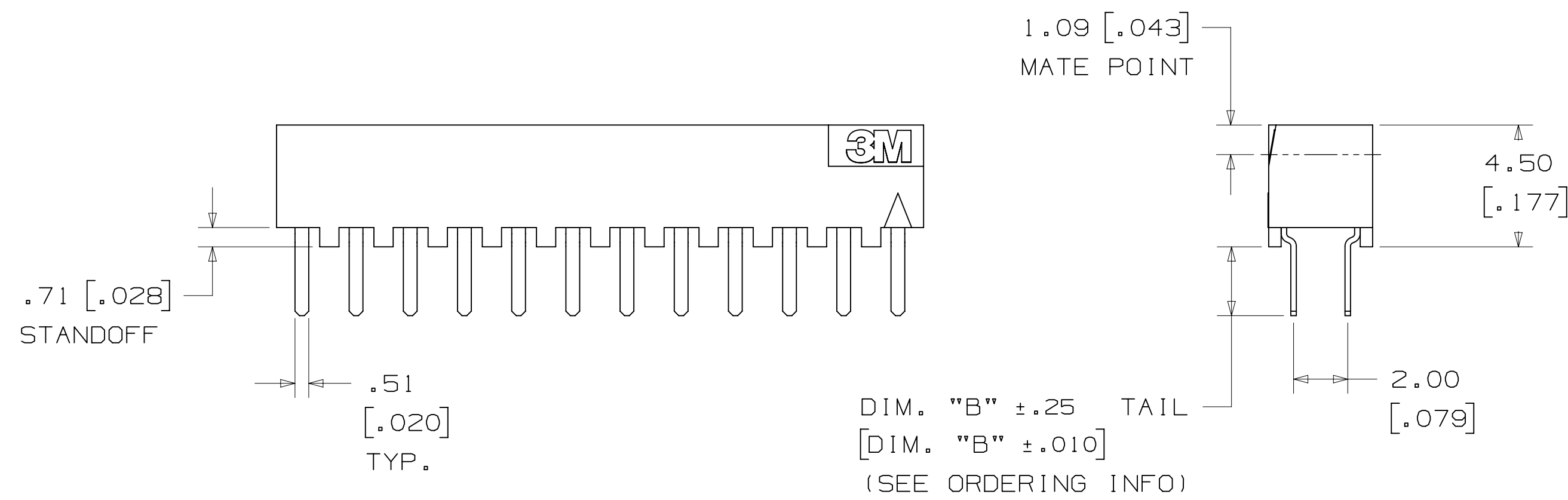
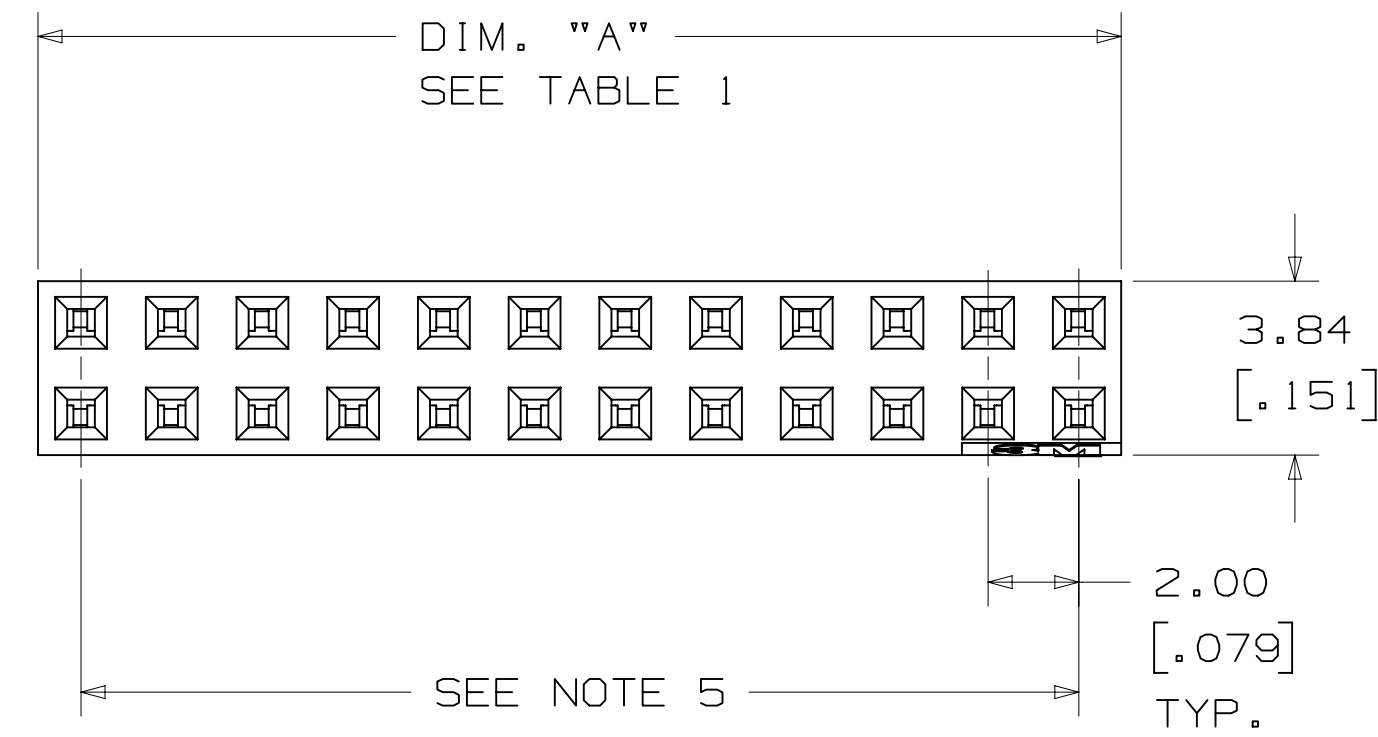

CONTACT QTY.	DIM. "A"
04	3.96 [ .156 ]
06	5.87 [ .231 ]
08	7.87 [ .310 ]
10	9.88 [ .389 ]
12	11.86 [ .467 ]
14	13.87 [ .546 ]
16	15.88 [ .625 ]
18	17.88 [ .704 ]
20	19.86 [ .782 ]
22	21.87 [ .861 ]
24	23.88 [ .940 ]
26	25.88 [ 1.019 ]
28	27.86 [ 1.097 ]
30	29.87 [ 1.176 ]
32	31.88 [ 1.255 ]
34	33.88 [ 1.334 ]
36	35.86 [ 1.412 ]
38	37.87 [ 1.491 ]
40	39.88 [ 1.570 ]
42	41.88 [ 1.649 ]
44	43.87 [ 1.727 ]
46	45.87 [ 1.806 ]
48	47.88 [ 1.885 ]
50	49.89 [ 1.964 ]
52	51.87 [ 2.042 ]
54	53.87 [ 2.121 ]
56	55.88 [ 2.200 ]
58	57.86 [ 2.278 ]
60	59.87 [ 2.357 ]

ORDERING INFORMATION  
 STRAIGHT  
 1502XX-600X-RB

CONTACT QTY.:  
 SEE TABLE 1

SOLDER TAIL LENGTH:  
 DIMENSION "B"  
 1 = 1.4MM (SPECIAL ORDER)  
 2 = 2.54MM (STANDARD)

DESIGN REFERENCE	NEXT ASSEMBLY	REV	ECO	ISSUE DATE AND DESCRIPTION	DRFT	CHKD
				SEP 03, 2015 REDRAWN & REMOVED RIGHT ANGLE	JNC	ARM
APPROVED	DATE	DATE	DATE	DATE	DATE	DATE
CASTIGLIONE	SEP 03, 2015	MFG				
CHKD	DATE	APPRV	DATE	DATE	DATE	DATE
		G. MATHEWS	SEP 03, 2015			
DIVISION	DIVISION CODE	© 3M COPYRIGHT 2017 This document and the information it contains are 3M property and may not be reproduced or further distributed without 3M permission, or used or disclosed other than for 3M authorized purposes. All rights reserved.				
DO NOT SCALE DRAWING	SCALE 6/1	TOLERANCES EXCEPT AS NOTED	<b>3M</b> 3M Center St. Paul, MN 55144			
THIRD ANGLE PROJECTION	INCHES: .00 ±.01, .000 ±.005, .0000 ±.0002	MILLIMETERS: 0 ±.2, .00 ±.13, .000 ±.005	TITLE: BOARDMOUNT SOCKET, 2MM X 2MM, STRAIGHT & SMT, PAC 20			
INTERPRET PER ASME Y14.5 - 2009	MAX SURFACE ROUGHNESS	MARKED SURFACES	CAGE NUMBER	SIZE	DRAWING NO.	REV.
			D78-5100-0519-8	D	1502	K
			MODEL	1502	DET	ISTS
					YES	NO
					SHT 2 OF 4	

78-5100-0519-8  
 DRAWING NUMBER  
 K  
 REVISION  
 Standard Time 12/7/2017 UTC Offset  
 Imaged: K.3 Central

3M™ BOARDMOUNT SOCKET, 1502 SERIES  
 2.00MM X 2.00MM STRAIGHT AND SURFACE MOUNT, PLATED THROUGH HOLE

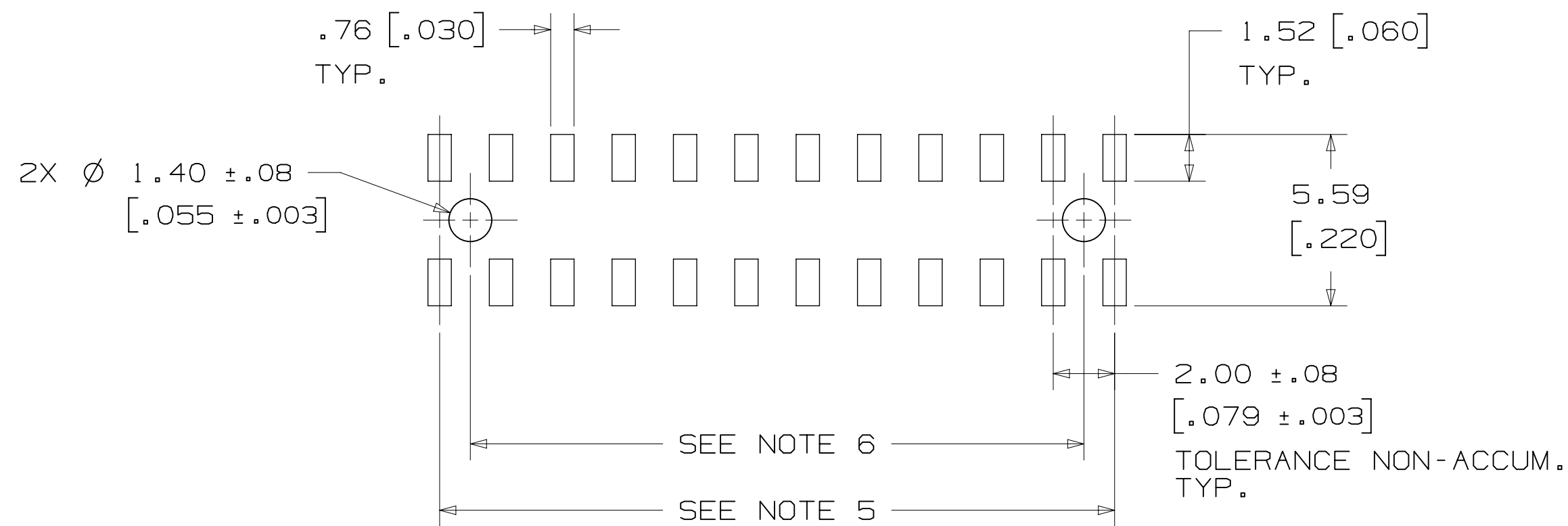
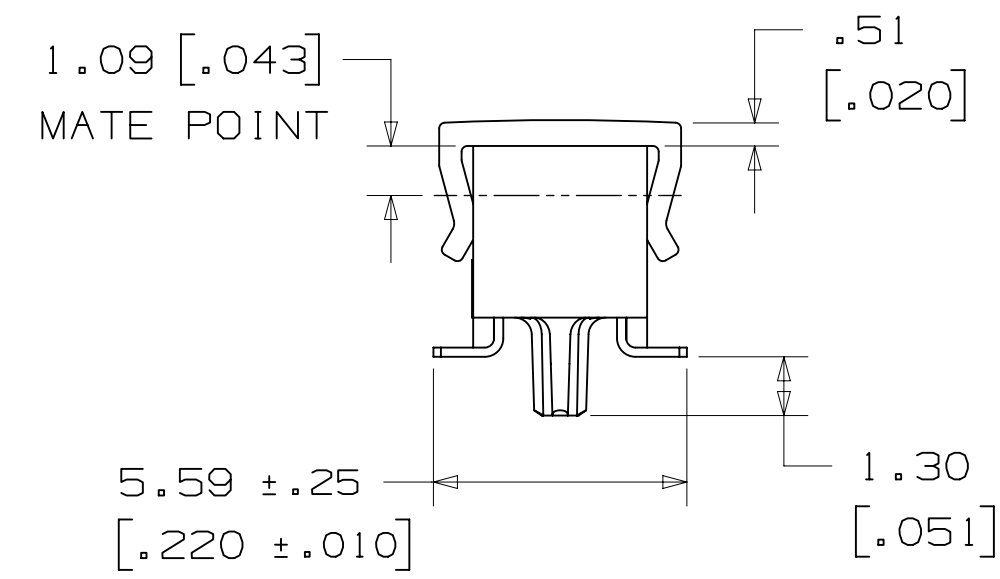
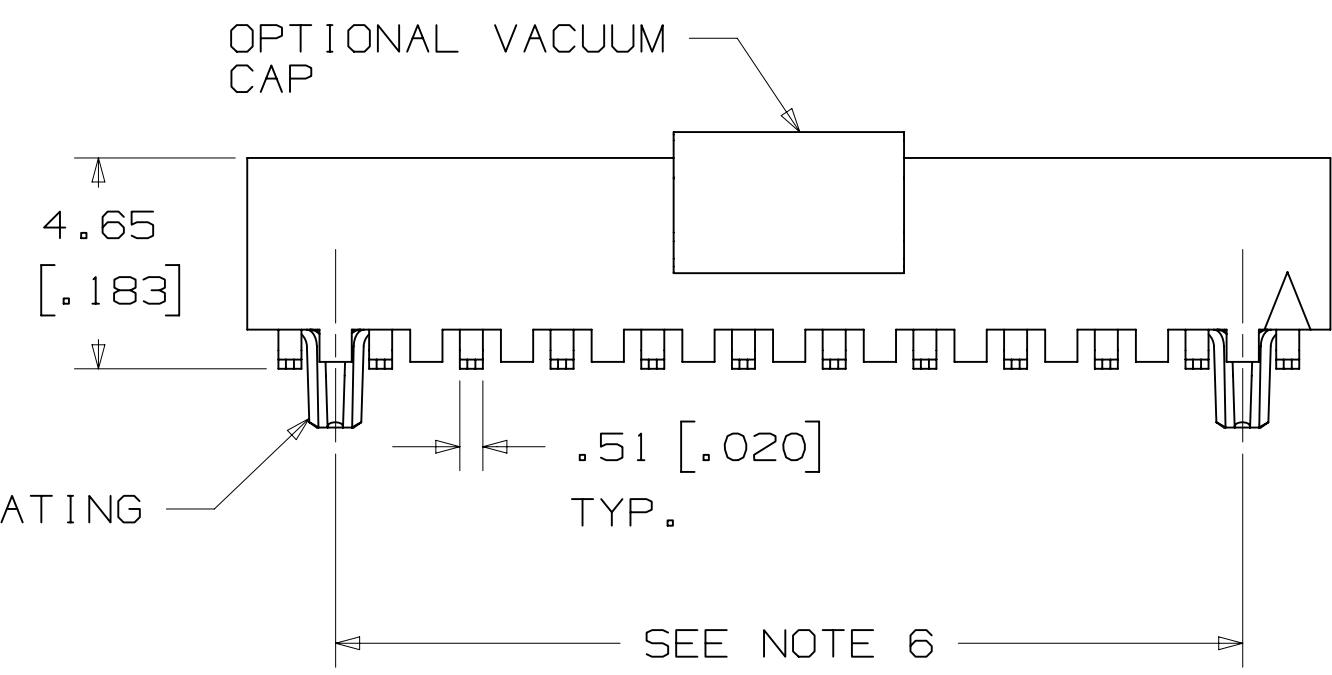
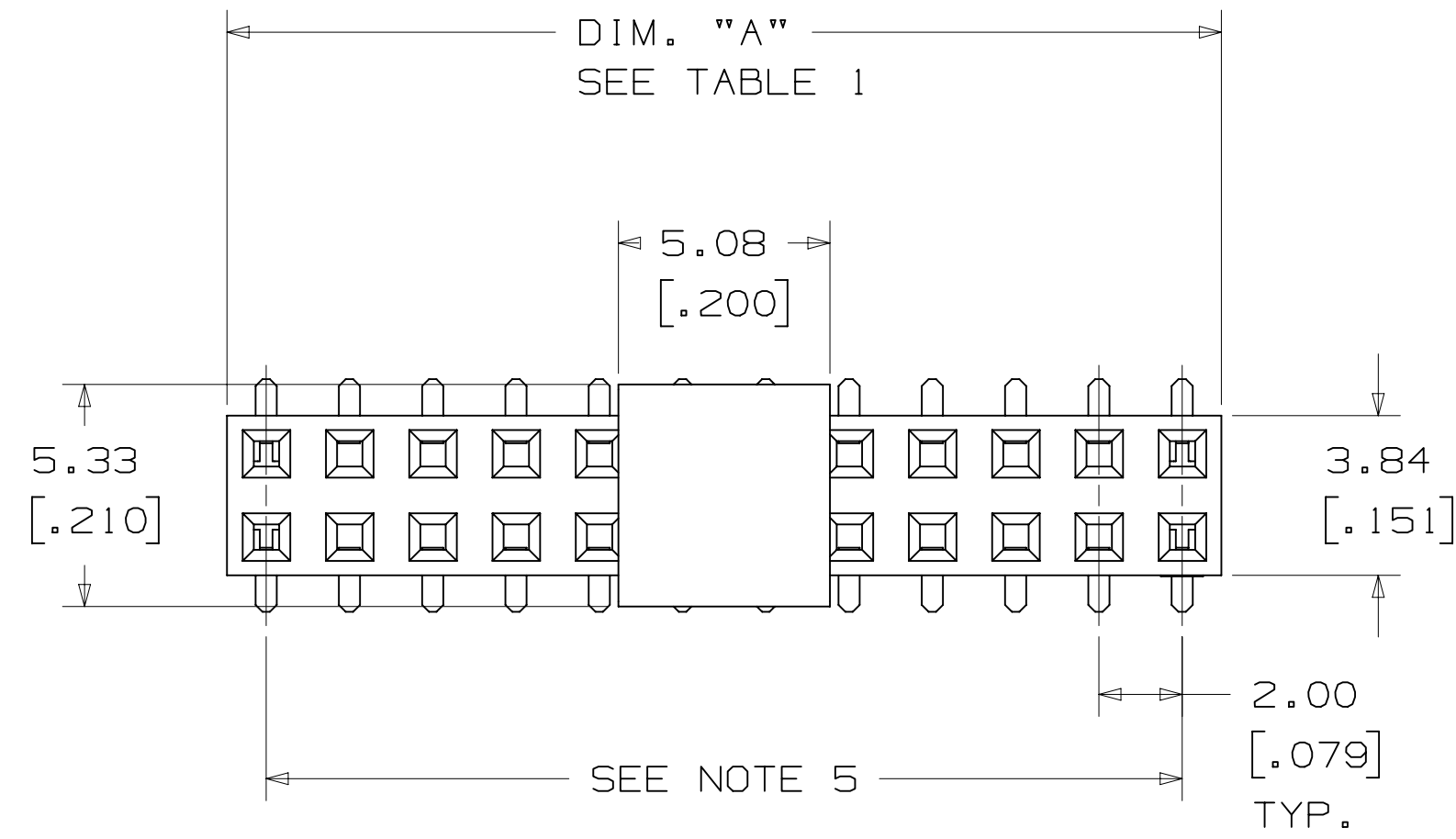

RECOMMENDED PAD PATTERN  
 (AS VIEWED FROM CONNECTOR SIDE)

CONTACT QTY.	DIM. "A"	TAPE WIDTH	ORDER CODE
04	3.96 [ .156 ]	N/A	N/A
06	5.87 [ .231 ]	N/A	N/A
08	7.87 [ .310 ]	24 MM	WB
10	9.88 [ .389 ]	24 MM	WB
12	11.86 [ .467 ]	24 MM	WB
14	13.87 [ .546 ]	24 MM	WB
16	15.88 [ .625 ]	24 MM	WB
18	17.88 [ .704 ]	44 MM	WD
20	19.86 [ .782 ]	44 MM	WD
22	21.87 [ .861 ]	44 MM	WD
24	23.88 [ .940 ]	44 MM	WD
26	25.88 [ 1.019 ]	44 MM	WD
28	27.86 [ 1.097 ]	44 MM	WD
30	29.87 [ 1.176 ]	44 MM	WD
32	31.88 [ 1.255 ]	56 MM	WE
34	33.88 [ 1.334 ]	56 MM	WE
36	35.86 [ 1.412 ]	56 MM	WE
38	37.87 [ 1.491 ]	56 MM	WE
40	39.88 [ 1.570 ]	56 MM	WE
42	41.88 [ 1.649 ]	56 MM	WE
44	43.87 [ 1.727 ]	72 MM	WF
46	45.87 [ 1.806 ]	72 MM	WF
48	47.88 [ 1.885 ]	72 MM	WF
50	49.89 [ 1.964 ]	72 MM	WF
52	51.87 [ 2.042 ]	72 MM	WF
54	53.87 [ 2.121 ]	72 MM	WF
56	55.88 [ 2.200 ]	72 MM	WF
58	57.86 [ 2.278 ]	88 MM	WG
60	59.87 [ 2.357 ]	88 MM	WG

ORDERING INFORMATION  
 SURFACE MOUNT  
 1502XX-20X0-RB-XX

CONTACT QTY.:  
 SEE TABLE 1

BOARD LOCATION POST:  
 0 = NONE (STANDARD)  
 2 = WITH BOARD LOCATION POSTS  
 (SPECIAL ORDER)

PACKAGING STYLE:  
 BLANK = TRAY PACKAGING  
 WX = TAPE & REEL PACKAGING  
 (SEE TABLE 1 FOR ORDERING CODE)

DESIGN REFERENCE	NEXT ASSEMBLY	REV	ECO	ISSUE DATE AND DESCRIPTION	DRFT	CHKD
				SEP 03, 2015		
APPROVED	DATE	APPROVED	DATE	MFG DATE		
	SEP 03, 2015	G. MATHEWS	SEP 03, 2015			
DIVISION	DIVISION CODE	© 3M COPYRIGHT 2017 This document and the information it contains are 3M property and may not be reproduced or further distributed without 3M permission, or used or disclosed other than for 3M authorized purposes. All rights reserved.				
DO NOT SCALE DRAWING	SCALE 6/1	TOLERANCES EXCEPT AS NOTED INCHES: .0 ±.1 .00 ±.01 .000 ±.005 .0000 ±.0002 MILLIMETERS: 0 ±.2 .0 ±.13 .00 ±.005				
THIRD ANGLE PROJECTION	INTERPRET PER ASME Y14.5 - 2009	CAGE NUMBER D78-5100-0519-8 MODEL 1502 DET. 1515 YES X NO SHT 3 OF 4				
MAX SURFACE ROUGHNESS	MARKED ONLY					

78-5100-0519-8  
 K  
 REV. 1  
 DATE SEP 03, 2015  
 APPR. G. MATHEWS  
 3M Center  
 St. Paul, MN 55144  
 © 3M COPYRIGHT 2017  
 This document and the information it contains are 3M property and may not be reproduced or further distributed without 3M permission, or used or disclosed other than for 3M authorized purposes. All rights reserved.  
 TITLE BOARDMOUNT SOCKET, 2MM X 2MM, STRAIGHT & SMT, PAC 20  
 CAGE NUMBER D78-5100-0519-8  
 MODEL 1502  
 DET. 1515  
 YES X NO  
 SHT 3 OF 4  
 78-5100-0519-8  
 K  
 REV. 1  
 DATE SEP 03, 2015  
 APPR. G. MATHEWS  
 3M Center  
 St. Paul, MN 55144  
 © 3M COPYRIGHT 2017  
 This document and the information it contains are 3M property and may not be reproduced or further distributed without 3M permission, or used or disclosed other than for 3M authorized purposes. All rights reserved.  
 TITLE BOARDMOUNT SOCKET, 2MM X 2MM, STRAIGHT & SMT, PAC 20  
 CAGE NUMBER D78-5100-0519-8  
 MODEL 1502  
 DET. 1515  
 YES X NO  
 SHT 3 OF 4

**Technical Information:** The technical information, recommendations and other statements contained in this document are based upon tests or experience that 3M believes are reliable, but the accuracy or completeness of such information is not guaranteed.

**Product Use:** Many factors beyond 3M's control and uniquely within user's knowledge and control can affect the use and performance of a 3M product in a particular application. Given the variety of factors that can affect the use and performance of a 3M product, user is solely responsible for evaluating the 3M product and determining whether it is fit for a particular purpose and suitable for user's method of application.

**Warranty, Limited Remedy, and Disclaimer:** Unless an additional warranty is specifically stated on the applicable 3M product packaging or product literature, 3M warrants that each 3M product meets the applicable 3M product specification at the time 3M ships the product. 3M MAKES NO OTHER WARRANTIES OR CONDITIONS, EXPRESS OR IMPLIED, INCLUDING, BUT NOT LIMITED TO, ANY IMPLIED WARRANTY OR CONDITION OF MERCHANTABILITY OR FITNESS FOR A PARTICULAR PURPOSE OR ANY IMPLIED WARRANTY OR CONDITION ARISING OUT OF A COURSE OF DEALING, CUSTOM OR USAGE OF TRADE. If the 3M product does not conform to this warranty, then the sole and exclusive remedy is, at 3M's option, replacement of the 3M product or refund of the purchase price.

**Limitation of Liability:** Except where prohibited by law, 3M will not be liable for any loss or damage arising from the 3M product, whether direct, indirect, special, incidental or consequential, regardless of the legal theory asserted, including warranty, contract, negligence or strict liability.

DESIGN REFERENCE		NEXT ASSEMBLY		REV	ECO	ISSUE DATE AND DESCRIPTION		DRFT	CHKD
K 63282		SEP 03, 2015				REDRAWN & REMOVED RIGHT ANGLE		JNC	ARM
DWF		DATE		MFG		DATE			
CASTIGLIONE		SEP 03, 2015							
CHKD		DATE		APPR		DATE			
				G. MATHEWS		SEP 03, 2015			
DIVISION		DIVISION CODE		 © 3M COPYRIGHT 2017 This document and the information it contains are 3M property and may not be reproduced or further distributed without 3M permission, or used or disclosed other than for 3M authorized purposes. All rights reserved.					
DO NOT SCALE DRAWING		SCALE 1/1		TOLERANCES EXCEPT AS NOTED					
THIRD ANGLE PROJECTION		INCHES		MILLIMETERS		TITLE <b>BOARDMOUNT SOCKET,          2MM X 2MM, STRAIGHT &amp;          SMT, PAC 20</b>			
INTERPRET PER ASME Y14.5 - 2009		0 ± .1 .00 ± .01 .0000 ± .0002		0 ± .2 .00 ± .13 .000 ± .005		CAGE NUMBER		DRAWING NO.	
MAX SURFACE ROUGHNESS		0 ± .2 .00 ± .13 .000 ± .005		1502		D 78-5100-0519-8		REV. K	
MARKED ONLY		ANGLES		MODEL		DET		SHT 4 OF 4	

78-5100-0519-8 DRAWING NUMBER  
 K REVISION  
 12/7/2017 UTC Offset  
 Standard Time  
 Central  
 K.3  
 Imaged

## X-ON Electronics

Largest Supplier of Electrical and Electronic Components

*Click to view similar products for [Headers & Wire Housings](#) category:*

*Click to view products by [3M](#) manufacturer:*

Other Similar products are found below :

[95000-104TRLF](#) [10135584-644402LF](#) [DF62W-EP2022PCA](#) [95000-106TRLF](#) [DF62W-2022SCA](#) [DF62W-EP2022PC](#) [2203348](#) [DF62W-2022SC](#) [1084018](#) [1029039](#) [1084017](#) [802-10-012-10-002000](#) [1112640](#) [1112639](#) [000-34000](#) [0009482033](#) [0009507031](#) [57102-S06-03LF](#) [57202-S52-04LF](#) [PCN6-15S-2.5E](#) [0039019024](#) [58102-G61-06LF](#) [582553-1](#) [0009508121](#) [0022285053](#) [0050291907](#) [018731A](#) [LY20-4P-DT1-P1E-BR](#) [02.125.8002.8](#) [60101931](#) [60598-1 \(Cut Strip\)](#) [M1625-3R/100](#) [61062-3](#) [61082-181009](#) [636-1427](#) [638009-1](#) [641938-9](#) [641991-4](#) [644168-1](#) [644827-2](#) [647662-1](#) [65039-019ELF](#) [65817-002LF](#) [65817-015LF](#) [65863-015LF](#) [66207-023LF](#) [67016-026LF](#) [67046-001LF](#) [67095-007LF](#) [68002-116](#)