

# Instructions and Parts List

---

**Scotch**<sup>™</sup>  
BRAND

## H-129

## Box Sealer

Model 27800

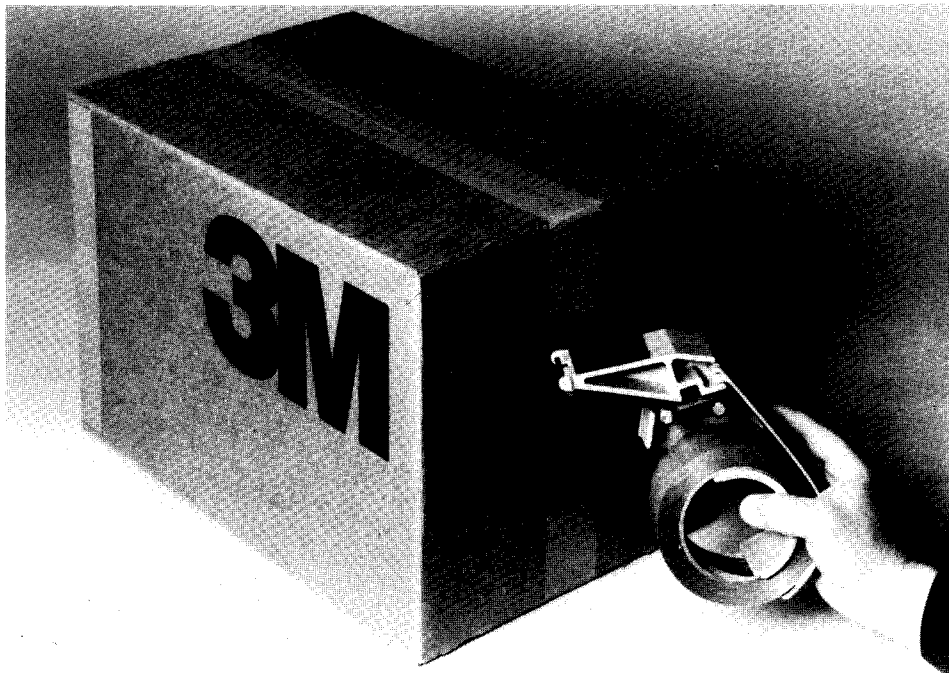

**H-129 Box Sealer, Model 27800**  
(shown with typical application)

### Description

The H-129 Box Sealer is designed primarily for “C” clip applications of film box sealing tapes to regular slotted containers. The use of this applicator provides a quick and easy one-hand method to apply, cut and seal tape clips with 2 inch [50 mm] minimum leg lengths.

### Specifications

**Tape:** For use with most “Scotch” brand Pressure-sensitive Box Sealing Tapes.

**Tape Widths:** 2 inches [50 mm] maximum.

**Tape Roll Diameter:** 5-3/4 inches [145 mm] maximum on a 3.00 inch [76,2 mm] core.

**Overall Dimensions:**

Length: 8-1/2 inches [215 mm]

Height: 4 inches [100 mm]

Width: 2-3/4 inches [70 mm]

Weight: 13 ounces [370 gm] packaged, 8 ounces [225 gm] unpackaged

## Loading Instructions



**WARNING** - Use care when working near the blade as the blade is sharp.

Figure 1 — The H-129 has a braking feature that allows the operator, by “squeezing down”, to apply tension on the tape roll.

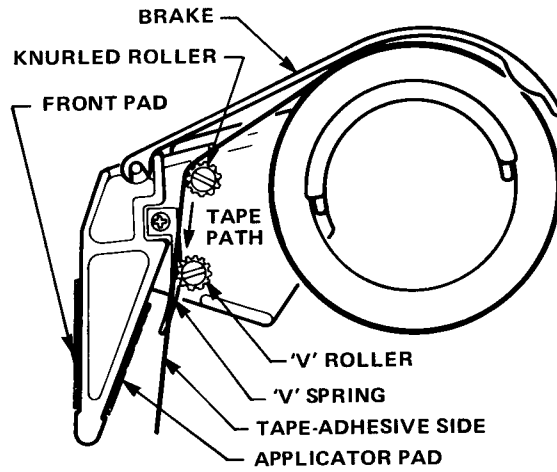

Figure 1

Figure 2 — Lift up on the brake (A), position the tape roll on the H-129 tape hub to dispense tape adhesive side down. Start the tape roll over the outer hub flange as indicated by arrow. Push the tape roll forward onto the hub and press downward to fully mount the tape roll.

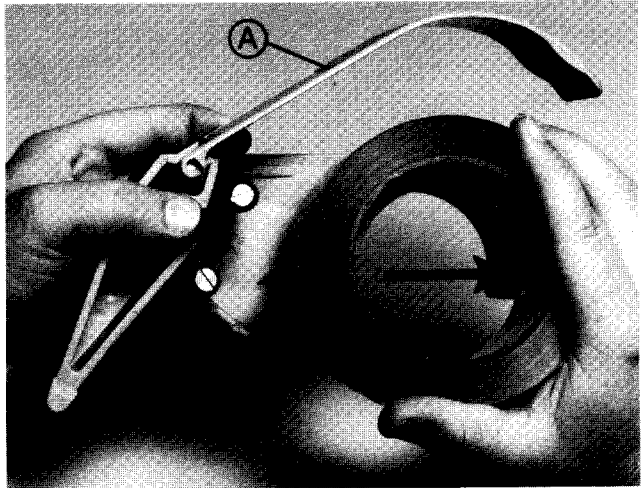

Figure 2

Figure 3 — Pull 4 - 6 inches [100-150 mm] of tape from the roll, thread the tape lead end over the knurled roller (B) and between the “V” roller (C) and “V” spring (D). Pull the tape forward so the tape tab lead end is just past the cut-off blade (E). Dispenser is ready to use.

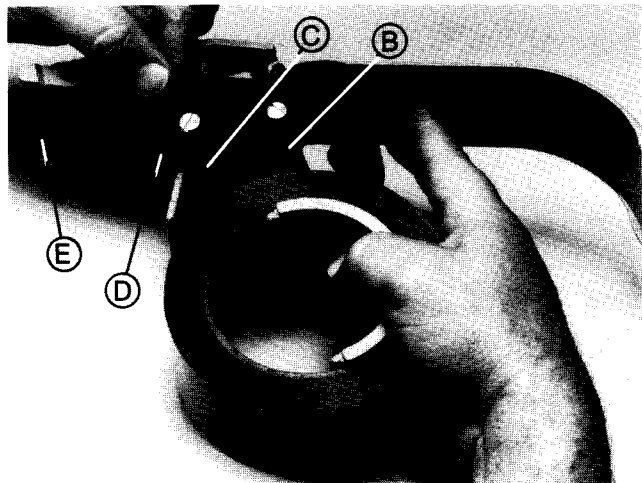

Figure 3

## Operating Instructions

### “C” Clip Application

Figure 4 — Place the H-129 applicator pad (F) with tape squarely against the far side of the box, centering the dispenser on the top flaps center seam. Bring the dispenser straight upward, sealing the lead end of tape to the side of the box with the applicator pad (F).

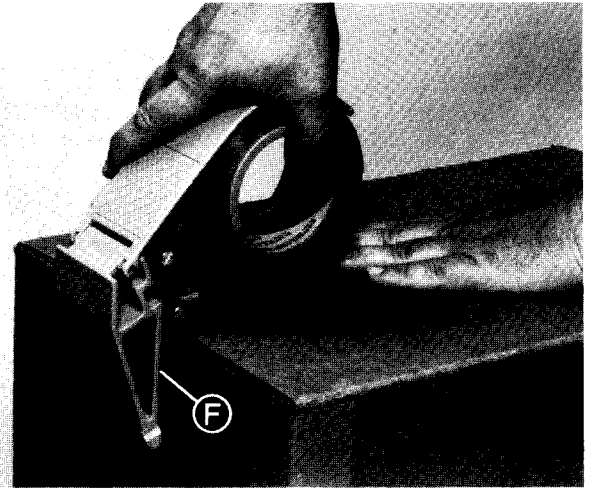

Figure 4

Figure 5 — Pull the H-129 over the box, following the top center seam of the box and continue the dispenser 2-1/2 to 3 inches [65 to 75 mm] beyond the near side of the box.

Apply hand pressure to the brake to provide tension on the tape web. Tilt the H-129 upward and bring the front pad (G) and tape web against the near side of the box. With hand pressure on the brake, push downward and rotate the H-129 slightly to cut and seal the tape to the side of the box.

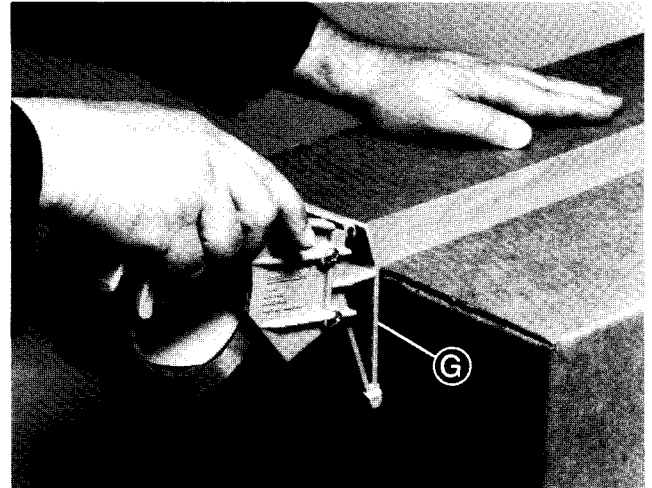

Figure 5

Figure 6 — Run the H-129 front pad (G) along the top taped seam to seal the tape and complete the application.

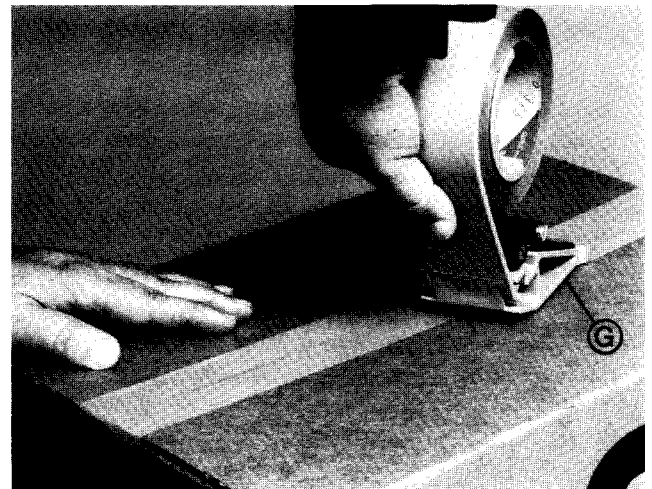

Figure 6

## How To Replace The Blade

Refer to Figure 7

**WARNING - Use care when working near the blade as the blade is sharp.**

1. Pull out old blade with pliers, or place tip of screwdriver in frame slot at rear of blade (7) and push outward.
2. Position blade with beveled side of cutting edge facing down and push to bottom of slot using wood, plastic or similar material which will not damage the cutting edge.

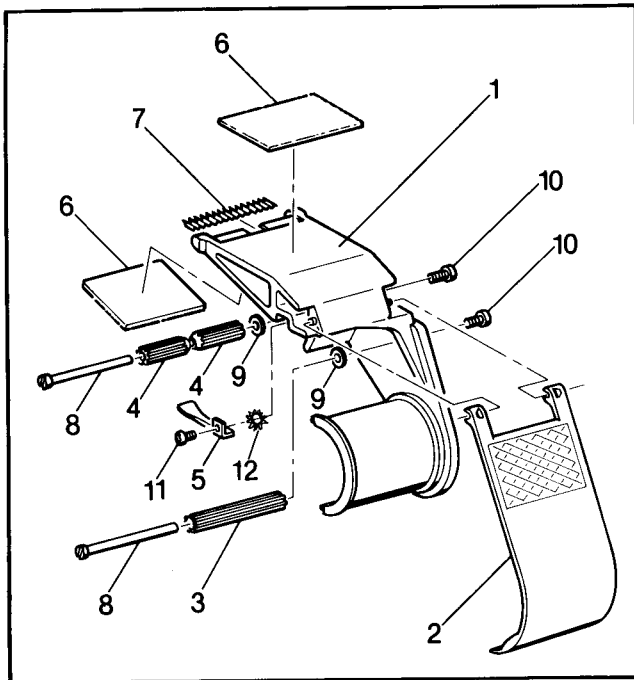

Figure 7

## How To Order Replacement Parts

1. Refer to Figure 7 to find part needed and reference number.
2. Refer to parts list for correct part number.

NOTE: Parts identified by (\*) are not available as a replacement stock item.

3. Order by **part number, description, dispenser name and model number.**
4. Replacement parts and part prices available direct from:

**3M/Tape Dispenser Parts**  
241 Venture Drive  
Amery, WI 54001-1325

800/344 9883  
FAX # 715/268 8153

Minimum billing on parts orders will be \$25.00.  
Replacement part prices available on request.  
\$10.00 restocking charge per invoice on returned parts.

## Parts List

Ref. No.	Part Number	Description
*1	78-8018-7692-7	Frame
2	78-8018-7688-5	Brake - Tape Roll
3	78-8018-7668-7	Roller - Knurled
4	78-8018-7670-3	Roller - Vee
5	78-8018-7667-9	Spring - Vee
6	78-8018-7690-1	Pad-Buffering
7	78-8018-7697-6	Blade
*8	78-8018-7682-8	Shaft - Roller
*9	78-8023-2211-1	Washer - Frame
*10	26-1002-8326-1	Screw - Mach. Phil Pan Hd, 10-32 x 5/8 Lg. "LOC-WEL"
*11	26-1002-2133-7	Screw-Self-Tap, Plastite, Phil Truss Hd, 6-19 x 3/8 Lg.
12	26-1001-7987-3	Washer, Lock Ext. Tooth Flat Type A No. 6.

**Equipment Warranty and Limited Remedy: THE FOLLOWING WARRANTY IS MADE IN LIEU OF ALL OTHER WARRANTIES, EXPRESS OR IMPLIED, INCLUDING, BUT NOT LIMITED TO, THE IMPLIED WARRANTY OF MERCHANTABILITY, THE IMPLIED WARRANTY OF FITNESS FOR A PARTICULAR PURPOSE AND ANY IMPLIED WARRANTY ARISING OUT OF A COURSE OF DEALING, A CUSTOM OR USAGE OF TRADE:**

3M warrants that its "Scotch" brand dispensers will be free from defects for ninety (90) days after delivery. If any part is proved to be defective within the warranty period, then the exclusive remedy and 3M's and seller's sole obligation shall be, at 3M's option, to repair or replace the part, provided the defective part is returned immediately to 3M's factory or an authorized service station designated by 3M. A part will be presumed to have become defective after the warranty period unless 3M is notified of the problem no later than five (5) calendar days after the warranty period. If 3M is unable to repair or replace the part within a reasonable time, then 3M, at its option, will replace the equipment or refund the purchase price.

**Limitation of Liability:** 3M and seller shall not be liable for direct, indirect, special, incidental or consequential damages based upon breach of warranty, breach of contract, negligence, strict liability or any other legal theory.

The foregoing Equipment Warranty and Limited Remedy and Limitation of Liability may be changed only by a written agreement signed by an authorized officer of 3M and seller.

# 3M

**3M Masking and Packaging Systems Division**

3M Center Bldg 220-8W-01  
St. Paul, MN 55144-1000

"Scotch" is a trademark of 3M.  
St. Paul, Minnesota 55144-1000

Litho U.S.A.

© 3M 1996 34-7004-7253-2(G116.05)

## X-ON Electronics

Largest Supplier of Electrical and Electronic Components

*Click to view similar products for [Adhesive Tapes](#) category:*

*Click to view products by [3M](#) manufacturer:*

Other Similar products are found below :

[PF24.0W](#) [4718](#) [4516-1/4x36](#) [56-YELLOW-34"X72YD](#) [00-021200-13972-7](#) [021200-64630](#) [60 TAPE \(1"\)](#) [62-GRAY-12"X36YD](#) [62-GRAY-1"X36YD](#) [69-1"X36YD](#) [764-1"x36yd-Red](#) [764-1"x36yd-White](#) [PG ASSY](#) [926-1/4X18YD](#) [967454-1](#) [1194-14"X36YD](#) [1181 19MM X 16,5 METERS](#) [1182-7.7X10](#) [1245-34"X18YD](#) [1267](#) [130C-1X15FT](#) [130-1x10FT](#) [1345-3/8x18yrd](#) [1380-2"X8"](#) [E39-RS1-CA](#) [1900-48mm](#) [22-1/2X36YD](#) [2229-P-2-1/2x3-3/4](#) [88-SUPER-34X44FT](#) [890103N001](#) [2670](#) [SJ3527N-Black-1.5"x50yd](#) [EVK-TA-TM047NBH01](#) [AD-UCUSB-DCAUD-SPL](#) [20-1"X60YDS](#) [2020-18mmx55m](#) [H150](#) [3900-Blue](#) [3939-24mmx55m](#) [396-1"x36yd](#) [4016-34"x36yd](#) [4462W-12"x72yd](#) [44-TAN-14"X90YD](#) [4504-34x18](#) [471-Trans-1"x36yd-Bulk](#) [5414 34X36](#) [C-22](#) [35-Gray-1/2](#) [371-Tan-48mmx50m](#) [4008-12"X36YD](#)