

Features

- Stable 1.3MHz GBWP Over Temperature Range
- Stable 1.3MHz GBWP in V_{CM} from 0V to V_{DD}
- 0.7V/ μ s Slew Rate
- Only 80 μ A of Supply Current per Amplifier
- Excellent EMIRR: 80dB(1GHz)
- Offset Voltage: 400uV Maximum
- Offset Voltage Temperature Drift: 1uV/ $^{\circ}$ C
- Input Bias Current: 1pA Typical
- THD+Noise: -105dB at 1kHz, -90dB at 10kHz
- High CMRR/PSRR: 95dB/90dB
- Beyond the Rails Input Common-Mode Range
- High Output Current: 100mA
- No Phase Reversal for Overdriven Inputs
- Drives 2k Ω Resistive Loads
- Shutdown Current: 0.2 μ A (TP1541NA)
- Single +2.1V to +6.0V Supply Voltage Range
- -40 $^{\circ}$ C to 125 $^{\circ}$ C Operation Temperature Range
- ESD Rating:
Robust 8KV – HBM, 2KV – CDM and 500V – MM
- Green, Popular Type Package

Applications

- Audio Output
- Active Filters, ASIC Input or Output Amplifier
- Portable Instruments and Mobile Equipment
- Battery or Solar Powered Systems
- Smoke/Gas/Environment Sensors
- Piezo Electrical Transducer Amplifier
- Medical Equipment
- PCMCIA Cards

Description

TP154xA series are CMOS single/dual/quad op-amps with low offset, stable high frequency response, low power, low supply voltage, and rail-to-rail inputs and outputs. They incorporate 3PEAK's proprietary and patented design techniques to achieve best in-class performance among all micro-power CMOS amplifiers in its power class. The TP154xA family can be used as plug-in replacements for many commercially available op-amps to reduce power and improve input/output range and performance.

TP154xA are unity gain stable with Any Capacitive load with a constant 1.3MHz GBWP, 0.7V/ μ s slew rate while consuming only 80 μ A of quiescent current per amplifier. Analog trim and calibration routine reduce input offset voltage to below 0.4mV, and proprietary precision temperature compensation technique makes offset voltage temperature drift at 1 μ V/ $^{\circ}$ C. Adaptive biasing and dynamic compensation enables the TP154xA to achieve 'THD+Noise' for 1kHz/10kHz 2V_{PP} signal at -105dB and -90dB, respectively. Beyond the rails input and rail-to-rail output characteristics allow the full power-supply voltage to be used for signal range.

This combination of features makes the TP154xA ideal choices for battery-powered applications because they minimize errors due to power supply voltage variations over the lifetime of the battery and maintain high CMRR even for a rail-to-rail input op-amp. General audio output, remote battery-powered sensors, and smoke detector can benefit from the features of the TP154xA op-amps.

For applications that require power-down, the TP1541NA in popular type packages has a low-power shutdown mode that reduces supply current to 0.2 μ A, and forces the output into a high-impedance state.

3PEAK and the 3PEAK logo are registered trademarks of 3PEAK INCORPORATED. All other trademarks are the property of their respective owners.

Pin Configuration (Top View)

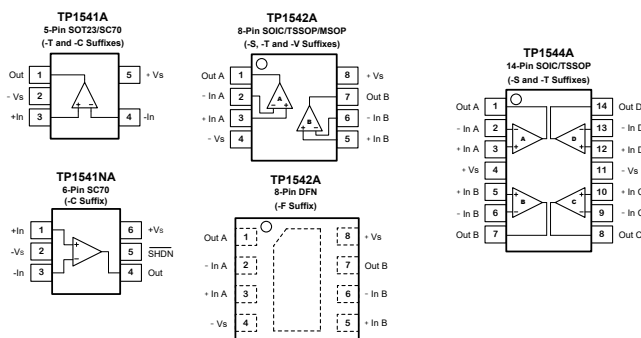

TP1541A/TP1541NA/TP1542A/TP1544A

Stable 1.3MHz, Precision, RRIO, Op Amps

Absolute Maximum Ratings ^{Note 1}

Supply Voltage: $V^+ - V^-$7.0V	Output Short-Circuit Duration ^{Note 3} Infinite
Input Voltage..... $V^- - 0.3$ to $V^+ + 0.3$	Operating Temperature Range.....-40°C to 125°C
Input Current: +IN, -IN, SHDN ^{Note 2} ± 10 mA	Maximum Junction Temperature..... 150°C
Differential Input Voltage..... ± 7 V	Storage Temperature Range..... -65°C to 150°C
SHDN Pin Voltage..... V^- to V^+	Lead Temperature (Soldering, 10 sec) 260°C

Note 1: Stresses beyond those listed under Absolute Maximum Ratings may cause permanent damage to the device. Exposure to any Absolute Maximum Rating condition for extended periods may affect device reliability and lifetime.

Note 2: The inputs are protected by ESD protection diodes to each power supply. If the input extends more than 500mV beyond the power supply, the input current should be limited to less than 10mA.

Note 3: A heat sink may be required to keep the junction temperature below the absolute maximum. This depends on the power supply voltage and how many amplifiers are shorted. Thermal resistance varies with the amount of PC board metal connected to the package. The specified values are for short traces connected to the leads.

ESD, Electrostatic Discharge Protection

Symbol	Parameter	Condition	Minimum Level	Unit
HBM	Human Body Model ESD	MIL-STD-883H Method 3015.8	8	kV
MM	Machine Model ESD	JEDEC-EIA/JESD22-A115	500	V
CDM	Charged Device Model ESD	JEDEC-EIA/JESD22-C101E	2	kV

Order Information

Model Name	Order Number	Package	Transport Media, Quantity	Marking Information
TP1541A	TP1541A-TR	5-Pin SOT23	Tape and Reel, 3000	541
TP1541NA	TP1541NA-CR	6-Pin SC70	Tape and Reel, 3000	54N
TP1542A	TP1542A-SR	8-Pin SOIC	Tape and Reel, 4000	1542A
	TP1542A-VR	8-Pin MSOP	Tape and Reel, 3000	1542A
	TP1542A-FR	8-Pin DFN	Tape and Reel, 3000	542
TP1544A	TP1544A-SR	14-Pin SOIC	Tape and Reel, 2500	1544A
	TP1544A-TR	14-Pin TSSOP	Tape and Reel, 3000	1544A

Electrical Characteristics

The specifications are at $T_A = 27^\circ\text{C}$. $V_S = 5\text{V}$, $V_{CM} = 2.5\text{V}$, $R_L = 2\text{k}\Omega$, $C_L = 100\text{pF}$, Unless otherwise noted.

SYMBOL	PARAMETER	CONDITIONS	MIN	TYP	MAX	UNITS
V_{OS}	Input Offset Voltage	$V_{CM} = 0\text{V to } 3\text{V}$	-400	± 50	+400	μV
$V_{OS\ TC}$	Input Offset Voltage Drift	$-40^\circ\text{C to } 125^\circ\text{C}$		1		$\mu\text{V}/^\circ\text{C}$
I_B	Input Bias Current	$T_A = 27^\circ\text{C}$		1	10	pA
		$T_A = 85^\circ\text{C}$		25		pA
I_{OS}	Input Offset Current			0.001		pA
V_n	Input Voltage Noise	$f = 0.1\text{Hz to } 10\text{Hz}$		7		μV_{PP}
e_n	Input Voltage Noise Density	$f = 1\text{kHz}$		27		$\text{nV}/\sqrt{\text{Hz}}$
i_n	Input Current Noise	$f = 1\text{kHz}$		2		$\text{fA}/\sqrt{\text{Hz}}$
C_{IN}	Input Capacitance	Differential		7.76		pF
		Common Mode		6.87		
CMRR	Common Mode Rejection Ratio	$V_{CM} = 0.1\text{V to } 2.6\text{V}$	85	95		dB
V_{CM}	Common-mode Input Voltage Range		$V^- - 0.3$		$V^+ + 0.3$	V
PSRR	Power Supply Rejection Ratio	$V_{CM} = 2.5\text{V}$, $V_S = 3\text{V to } 5\text{V}$	77	90		dB
A_{VOL}	Open-Loop Large Signal Gain	$R_{LOAD} = 10\text{k}\Omega$	98	120		dB
V_{OL} , V_{OH}	Output Swing from Supply Rail	$R_{LOAD} = 10\text{k}\Omega$		3	6	mV
R_{OUT}	Closed-Loop Output Impedance	$G = 1$, $f = 1\text{kHz}$, $I_{OUT} = 0$		0.002		Ω
R_O	Open-Loop Output Impedance	$f = 1\text{kHz}$, $I_{OUT} = 0$		125		Ω
I_{SC}	Output Short-Circuit Current	Sink or source current	90	100		mA
I_O	Output Current	Sink or source current, Output 1V Drop		50		mA
V_{DD}	Supply Voltage		2.1		6.0	V
I_Q	Quiescent Current per Amplifier	$V_S = 5\text{V}$		80	110	μA
PM	Phase Margin	$R_{LOAD} = 1\text{k}\Omega$, $C_{LOAD} = 60\text{pF}$		65		$^\circ$
GM	Gain Margin	$R_{LOAD} = 1\text{k}\Omega$, $C_{LOAD} = 60\text{pF}$		15		dB
GBWP	Gain-Bandwidth Product	$f = 1\text{kHz}$		1.3		MHz
SR	Slew Rate	$A_V = 1$, $V_{OUT} = 1.5\text{V to } 3.5\text{V}$, $C_{LOAD} = 60\text{pF}$, $R_{LOAD} = 1\text{k}\Omega$		0.7		$\text{V}/\mu\text{s}$
t_s	Settling Time, 0.1% Settling Time, 0.01%	$A_V = -1$, $V_{OUT} = 1\text{V Step}$		3.7		μs
				4.9		
THD+N	Total Harmonic Distortion and Noise	$f = 1\text{kHz}$, $A_V = 1$, $R_L = 2\text{k}\Omega$, $V_{OUT} = 1\text{Vp-p}$		-105		dB
X_{talk}	Channel Separation	$f = 1\text{kHz}$, $R_L = 2\text{k}\Omega$		110		dB
$I_{Q(OFF)}$	Supply Current in Shutdown	$V_S = 5\text{V}$		0.2		μA
I_{SHDN}	Shutdown Pin Current	$V_{SHDN} = 0.5\text{V}$		-0.15		μA
		$V_{SHDN} = 1.5\text{V}$		-0.15		μA
I_{LEAK}	Output Leakage Current in Shutdown	$V_{SHDN} = 0\text{V}$, $V_{OUT} = 0\text{V}$		-20		pA
		$V_{SHDN} = 0\text{V}$, $V_{OUT} = 5\text{V}$		20		pA
V_{IL}	SHDN Input Low Voltage	Disable			0.5	V
V_{IH}	SHDN Input High Voltage	Enable	1.0			V
t_{ON}	Turn-On Time	SHDN Toggle from 0V to 5V		20		ms
t_{OFF}	Turn-Off Time	SHDN Toggle from 5V to 0V		20		ms

Typical Performance Characteristics

$V_S = \pm 2.75V$, $V_{CM} = 0V$, $R_L = \text{Open}$, unless otherwise specified.

Offset Voltage Production Distribution

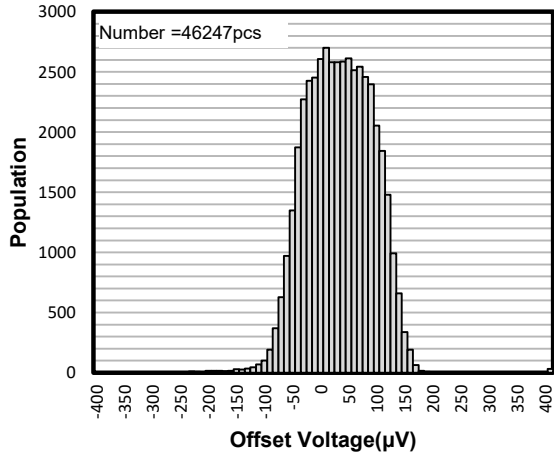

Unity Gain Bandwidth vs. Temperature

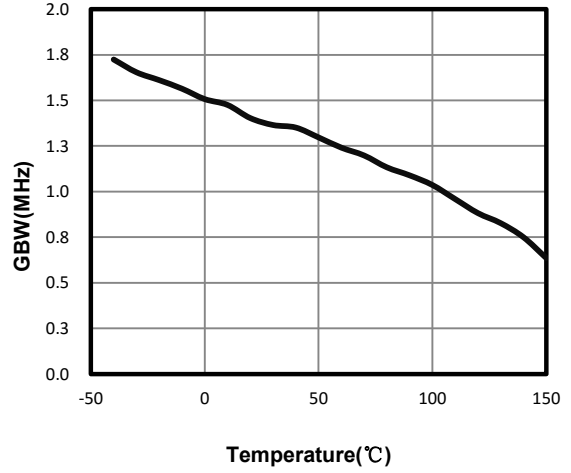

Open-Loop Gain and Phase

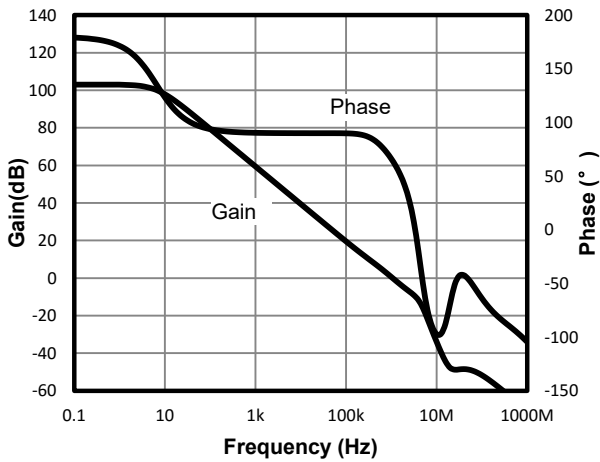

Input Voltage Noise Spectral Density

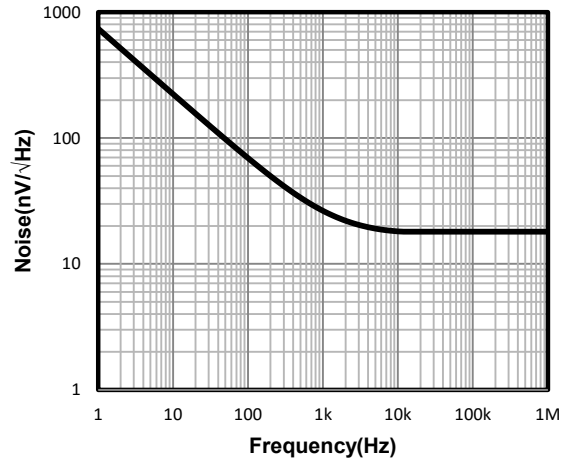

Input Bias Current vs. Temperature

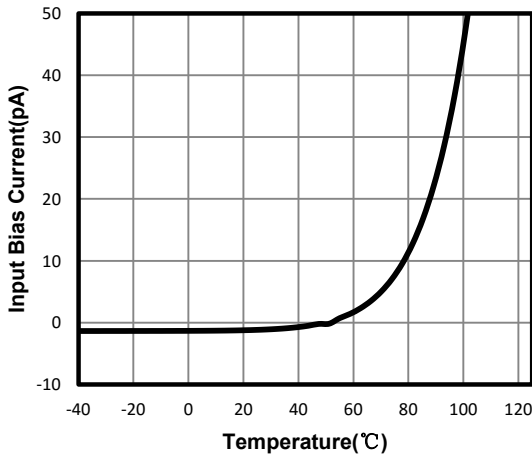

Input Bias Current vs. Input Common Mode Voltage

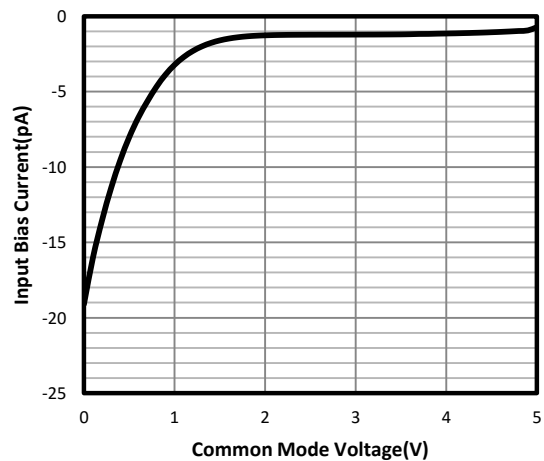

Typical Performance Characteristics

$V_S = \pm 2.75V$, $V_{CM} = 0V$, $R_L = \text{Open}$, unless otherwise specified. (Continued)

Common Mode Rejection Ratio

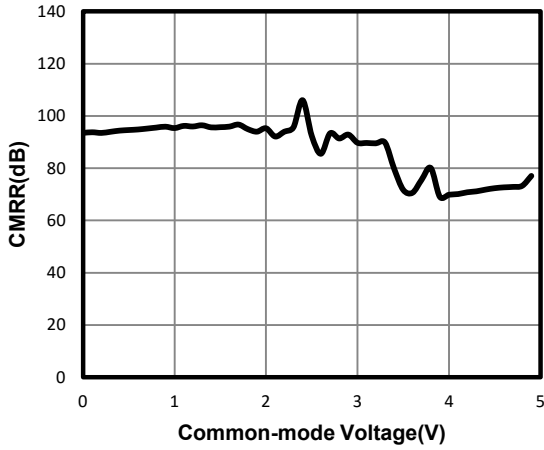

CMRR vs. Frequency

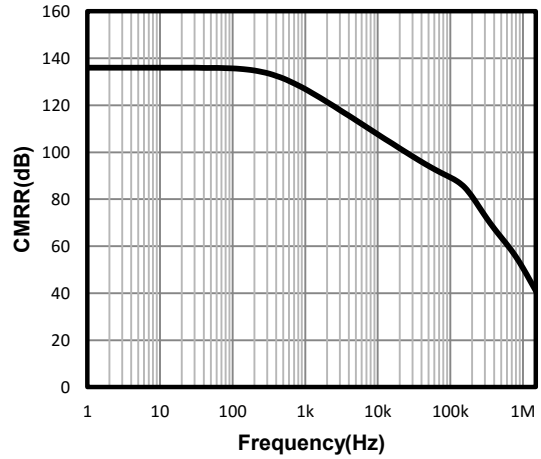

Quiescent Current vs. Temperature

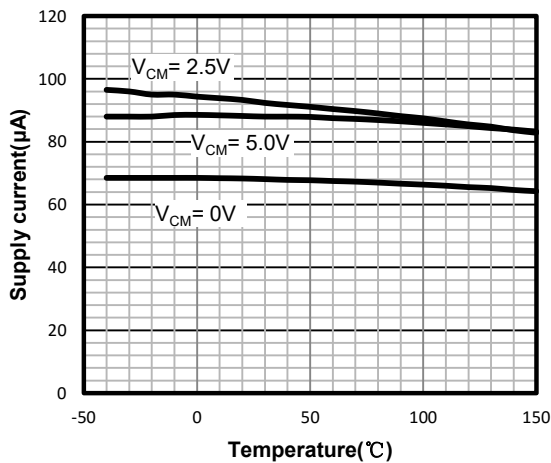

Short Circuit Current vs. Temperature

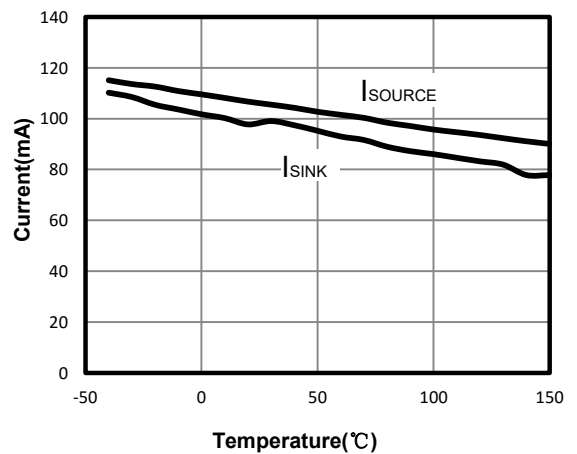

Power-Supply Rejection Ratio

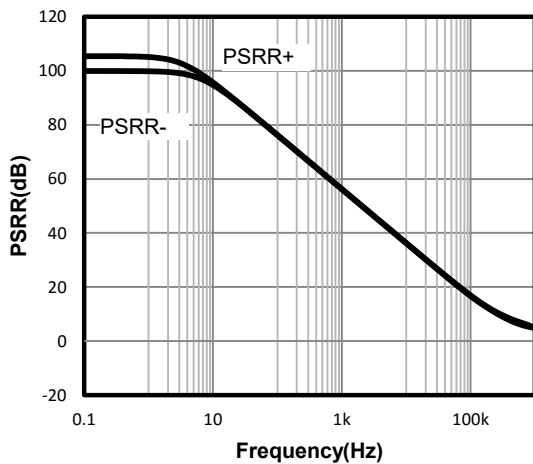

Quiescent Current vs. Supply Voltage

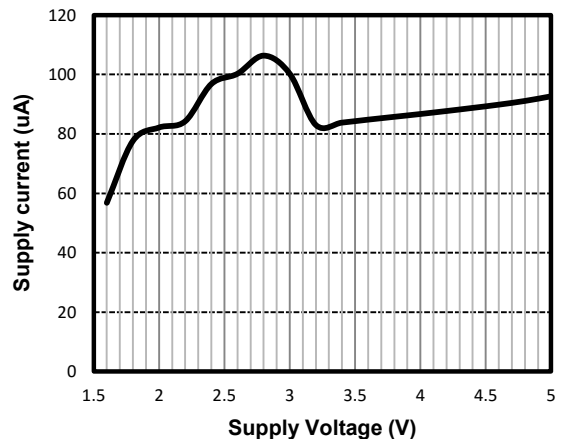

Typical Performance Characteristics

$V_S = \pm 2.75V$, $V_{CM} = 0V$, $R_L = \text{Open}$, unless otherwise specified. (Continued)

PSRR vs. Temperature

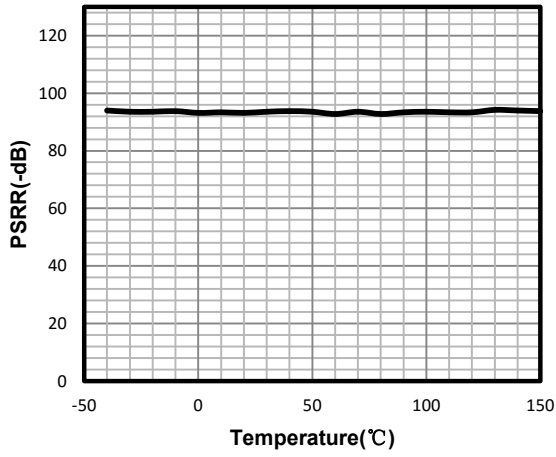

CMRR vs. Temperature

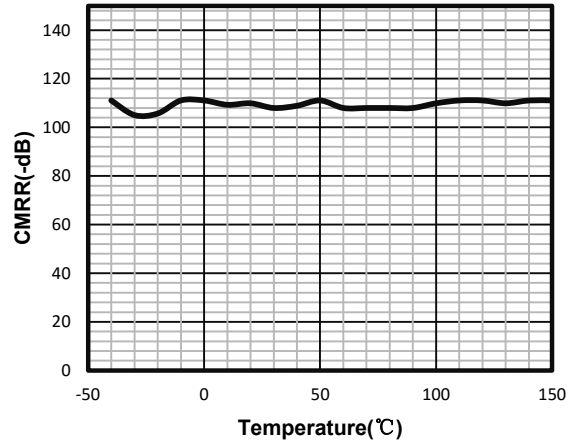

EMIRR IN+ vs. Frequency

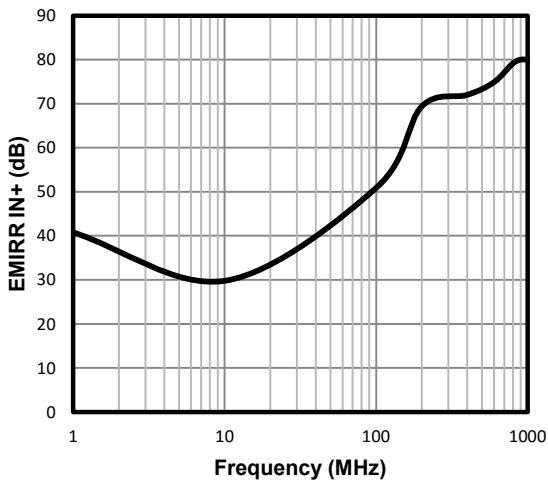

Large-Scale Step Response

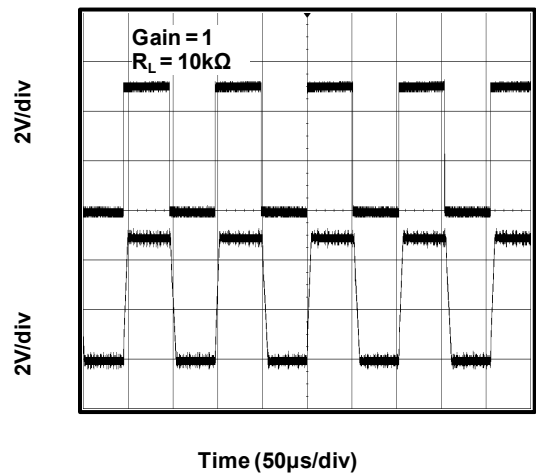

Negative Over-Voltage Recovery

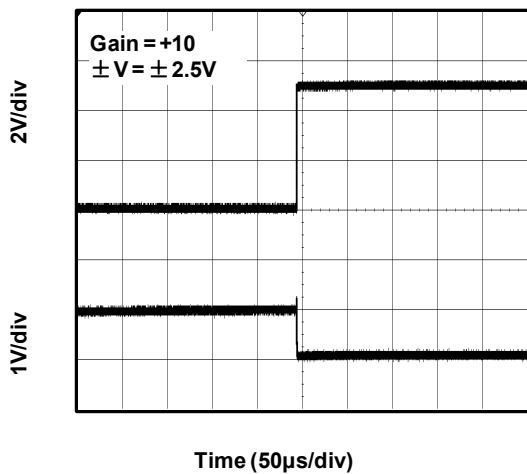

Positive Over-Voltage Recovery

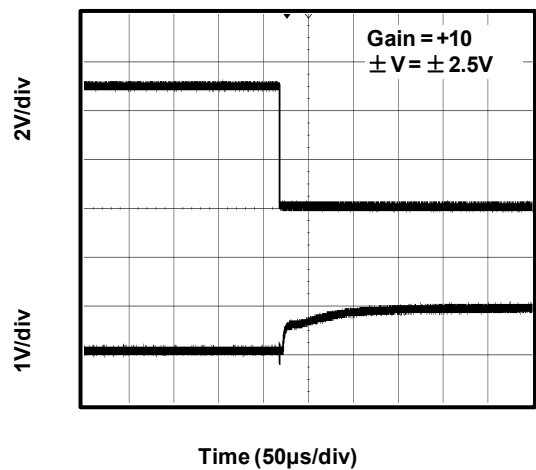

Typical Performance Characteristics

$V_S = \pm 2.75V$, $V_{CM} = 0V$, $R_L = \text{Open}$, unless otherwise specified. (Continued)

0.1 Hz TO 10 Hz Input Voltage Noise

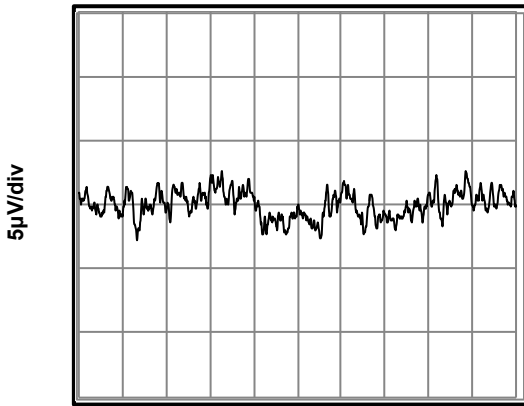

Time (1s/div)

Offset Voltage vs Common-Mode Voltage

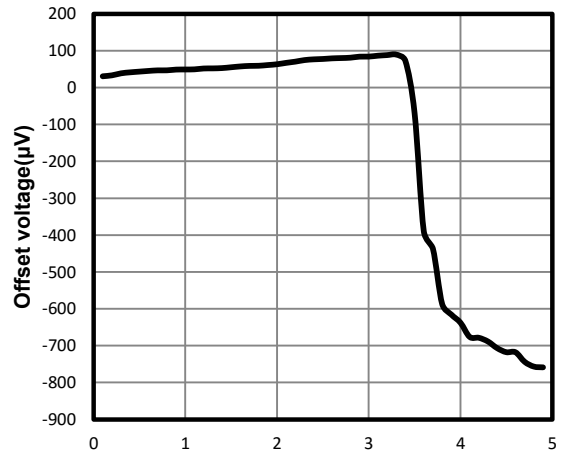

Common-mode voltage(V)

Positive Output Swing vs. Load Current

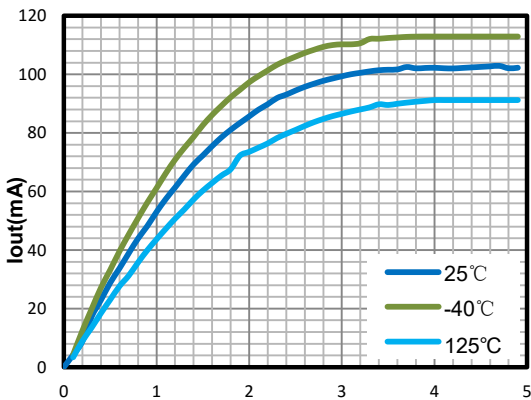

Vout Dropout (V)

Negative Output Swing vs. Load Current

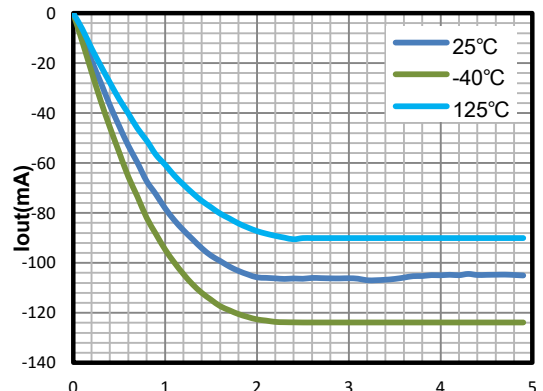

Vout Dropout (V)

Offset Voltage vs. Temperature

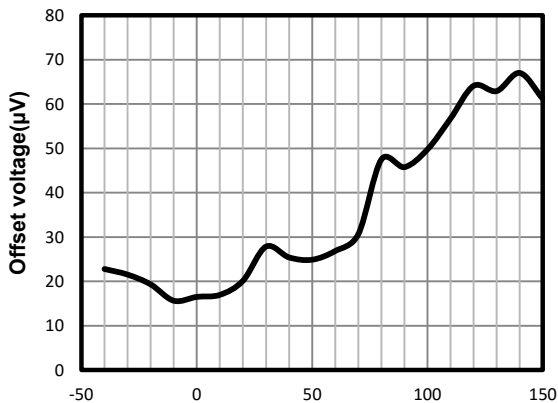

Temperature(°C)

Stable 1.3MHz, Precision, RRIO, Op Amps

Pin Functions

-IN: Inverting Input of the Amplifier. Voltage range of this pin can go from $V^- - 0.3V$ to $V^+ + 0.3V$.

+IN: Non-Inverting Input of Amplifier. This pin has the same voltage range as -IN.

+V_S: Positive Power Supply. Typically the voltage is from 2.1V to 6V. Split supplies are possible as long as the voltage between V+ and V- is between 2.1V and 6V. A bypass capacitor of 0.1 μ F as close to the part as possible should be used between power supply pins or between supply pins and ground.

N/C: No Connection.

-V_S: Negative Power Supply. It is normally tied to ground. It can also be tied to a voltage other than ground as long as the voltage between V⁺ and V⁻ is from 2.1V to 6V. If it is not connected to ground, bypass it with a capacitor of 0.1 μ F as close to the part as possible.

SHDN: Active Low Shutdown. Shutdown threshold is **1.0V** above negative supply rail. If unconnected, the amplifier is automatically enabled.

OUT: Amplifier Output. The voltage range extends to within millivolts of each supply rail.

Operation

The TP154xA family input signal range extends beyond the negative and positive power supplies. The output can even extend all the way to the negative supply. The input stage is comprised of two CMOS differential amplifiers, a PMOS stage and NMOS stage that are active over different ranges of common mode input voltage. The

Class-AB control buffer and output bias stage uses a proprietary compensation technique to take full advantage of the process technology to drive very high capacitive loads. This is evident from the transient over shoot measurement plots in the Typical Performance Characteristics.

Applications Information

Low Supply Voltage and Low Power Consumption

The TP154xA family of operational amplifiers can operate with power supply voltages from 2.1V to 6.0V. Each amplifier draws only 80 μ A quiescent current. The low supply voltage capability and low supply current are ideal for portable applications demanding HIGH CAPACITIVE LOAD DRIVING CAPABILITY and CONSTANT WIDE BANDWIDTH. The TP154xA family is optimized for wide bandwidth low power applications. They have an industry leading high GBWP to power ratio and are unity gain stable for ANY CAPACITIVE load. When the load capacitance increases, the increased capacitance at the output pushed the non-dominant pole to lower frequency in the open loop frequency response, lowering the phase and gain margin. Higher gain configurations tend to have better capacitive drive capability than lower gain configurations due to lower closed loop bandwidth and hence higher phase margin.

Low Input Referred Noise

The TP154xA family provides a low input referred noise density of 27nV/ $\sqrt{\text{Hz}}$ at 1kHz. The voltage noise will grow slowly with the frequency in wideband range, and the input voltage noise is typically 7 μ V_{P,P} at the frequency of 0.1Hz to 10Hz.

Low Input Offset Voltage

The TP154xA family has a low offset voltage of 400 μ V maximum which is essential for precision applications. The offset voltage is trimmed with a proprietary trim algorithm to ensure low offset voltage for precision signal processing requirement.

Low Input Bias Current

The TP154xA family is a CMOS OPA family and features very low input bias current in pA range. The low input bias current allows the amplifiers to be used in applications with high resistance sources. Care must be taken to minimize PCB Surface Leakage. See below section on “PCB Surface Leakage” for more details.

PCB Surface Leakage

In applications where low input bias current is critical, Printed Circuit Board (PCB) surface leakage effects need to be considered. Surface leakage is caused by humidity, dust or other contamination on the board. Under low humidity conditions, a typical resistance between nearby traces is $10^{12}\Omega$. A 5V difference would cause 5pA of current to flow, which is greater than the TP154xA OPA’s input bias current at +27°C ($\pm 1\text{pA}$, typical). It is recommended to use multi-layer PCB layout and route the OPA’s -IN and +IN signal under the PCB surface.

The effective way to reduce surface leakage is to use a guard ring around sensitive pins (or traces). The guard ring is biased at the same voltage as the sensitive pin. An example of this type of layout is shown in Figure 1 for Inverting Gain application.

1. For Non-Inverting Gain and Unity-Gain Buffer:

- Connect the non-inverting pin (V_{IN+}) to the input with a wire that does not touch the PCB surface.
- Connect the guard ring to the inverting input pin (V_{IN-}). This biases the guard ring to the Common Mode input voltage.

2. For Inverting Gain and Trans-impedance Gain Amplifiers (convert current to voltage, such as photo detectors):

- Connect the guard ring to the non-inverting input pin (V_{IN+}). This biases the guard ring to the same reference voltage as the op-amp (e.g., $V_{DD}/2$ or ground).
- Connect the inverting pin (V_{IN-}) to the input with a wire that does not touch the PCB surface.

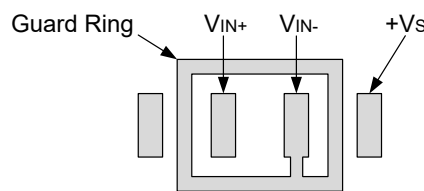

Figure 1

Ground Sensing and Rail to Rail Output

The TP154xA family has excellent output drive capability, delivering over 100mA of output drive current. The output stage is a rail-to-rail topology that is capable of swinging to within 10mV of either rail. Since the inputs can go 300mV beyond either rail, the op-amp can easily perform ‘true ground’ sensing.

The maximum output current is a function of total supply voltage. As the supply voltage to the amplifier increases, the output current capability also increases. Attention must be paid to keep the junction temperature of the IC below 150°C when the output is in continuous short-circuit. The output of the amplifier has reverse-biased ESD diodes connected to each supply. The output should not be forced more than 0.5V beyond either supply, otherwise current will flow through these diodes.

ESD

The TP154xA family has reverse-biased ESD protection diodes on all inputs and output. Input and out pins can not be biased more than 300mV beyond either supply rail.

Shut-down

The single channel OPA versions have $\overline{\text{SHDN}}$ pins that can shut down the amplifier to less than 0.2 μA supply current. The $\overline{\text{SHDN}}$ pin voltage needs to be within 0.5V of V_{-} for the amplifier to shut down. During shutdown, the output will be in high output resistance state, which is suitable for multiplexer applications. When left floating, the $\overline{\text{SHDN}}$ pin is internally pulled up to the positive supply and the amplifier remains enabled.

Driving Large Capacitive Load

The TP154xA family of OPA is designed to drive large capacitive loads. Refer to Typical Performance Characteristics for “Phase Margin vs. Load Capacitance”. As always, larger load capacitance decreases overall phase margin in a feedback system where internal frequency compensation is utilized. As the load capacitance increases, the feedback loop’s phase margin decreases, and the closed-loop bandwidth is reduced. This produces gain peaking in the frequency response, with overshoot and ringing in output step response. The unity-gain buffer ($G = +1V/V$) is the most sensitive to large capacitive loads.

When driving large capacitive loads with the TP154xA OPA family (e.g., > 200 pF when $G = +1V/V$), a small series resistor at the output (R_{ISO} in Figure 3) improves the feedback loop’s phase margin and stability by making the output load resistive at higher frequencies.

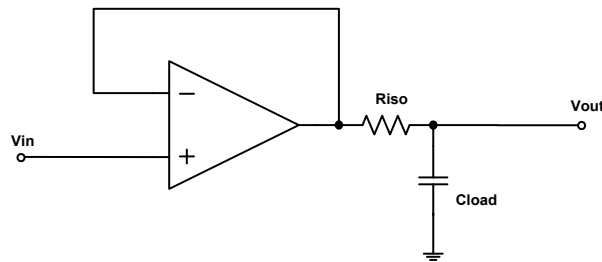

Figure 3

Power Supply Layout and Bypass

The TP154xA OPA’s power supply pin (V_{DD} for single-supply) should have a local bypass capacitor (i.e., $0.01\mu F$ to $0.1\mu F$) within 2mm for good high frequency performance. It can also use a bulk capacitor (i.e., $1\mu F$ or larger) within 100mm to provide large, slow currents. This bulk capacitor can be shared with other analog parts.

Ground layout improves performance by decreasing the amount of stray capacitance and noise at the OPA’s inputs and outputs. To decrease stray capacitance, minimize PCB board lengths and resistor leads, and place external components as close to the op amps’ pins as possible.

Proper Board Layout

To ensure optimum performance at the PCB level, care must be taken in the design of the board layout. To avoid leakage currents, the surface of the board should be kept clean and free of moisture. Coating the surface creates a barrier to moisture accumulation and helps reduce parasitic resistance on the board.

Keeping supply traces short and properly bypassing the power supplies minimizes power supply disturbances due to output current variation, such as when driving an ac signal into a heavy load. Bypass capacitors should be connected as closely as possible to the device supply pins. Stray capacitances are a concern at the outputs and the inputs of the amplifier. It is recommended that signal traces be kept at least 5mm from supply lines to minimize coupling.

A variation in temperature across the PCB can cause a mismatch in the Seebeck voltages at solder joints and other points where dissimilar metals are in contact, resulting in thermal voltage errors. To minimize these thermocouple effects, orient resistors so heat sources warm both ends equally. Input signal paths should contain matching numbers and types of components, where possible to match the number and type of thermocouple junctions. For example, dummy components such as zero value resistors can be used to match real resistors in the opposite input path. Matching components should be located in close proximity and should be oriented in the same manner. Ensure leads are of equal length so that thermal conduction is in equilibrium. Keep heat sources on the PCB as far away from amplifier input circuitry as is practical.

The use of a ground plane is highly recommended. A ground plane reduces EMI noise and also helps to maintain a constant temperature across the circuit board.

Instrumentation Amplifier

The TP154xA OPA series is well suited for conditioning sensor signals in battery-powered applications. Figure 4 shows a two op-amp instrumentation amplifier, using the TP154xA OPA.

The circuit works well for applications requiring rejection of Common Mode noise at higher gains. The reference voltage (V_{REF}) is supplied by a low-impedance source. In single voltage supply applications, V_{REF} is typically $V_{DD}/2$.

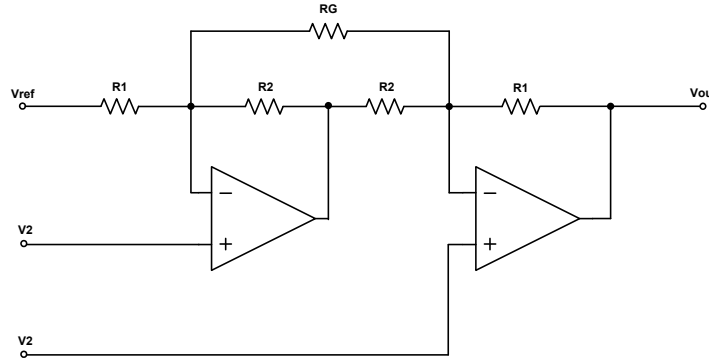

$$V_{OUT} = (V_1 - V_2) \left(1 + \frac{R_1}{R_2} + \frac{2R_1}{R_G} \right) + V_{REF}$$

Figure 4

Gain-of-100 Amplifier Circuit

Figure 5 shows a Gain-of-100 amplifier circuit using two TP154xA OPAs. It draws 160uA total current from supply rail, and has a -3dB frequency at 100kHz.

Figure 6 shows the small signal frequency response of the circuit.

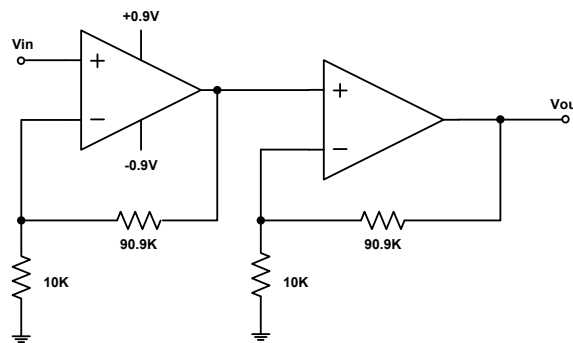

Figure 5: 100kHz, 160µA Gain-of-100 Amplifier

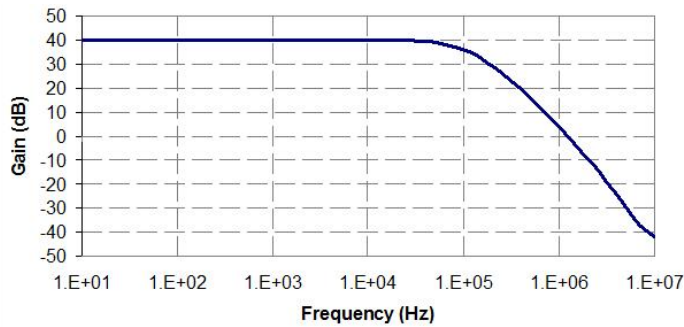

Figure 6: Frequency response of 100kHz, 160uA Gain-of-100 Amplifier

Buffered Chemical Sensor (pH) Probe

The TP154xA OPA has input bias current in the pA range. This is ideal in buffering high impedance chemical sensors such as pH probe. As an example, the circuit in Figure 7 eliminates expensive low-leakage cables that that is required to connect pH probe to metering ICs such as ADC, AFE and/or MCU. A TP154xA OPA and a lithium battery are housed in the probe assembly. A conventional low-cost coaxial cable can be used to carry OPA's output signal to subsequent ICs for pH reading.

Stable 1.3MHz, Precision, RRIO, Op Amps

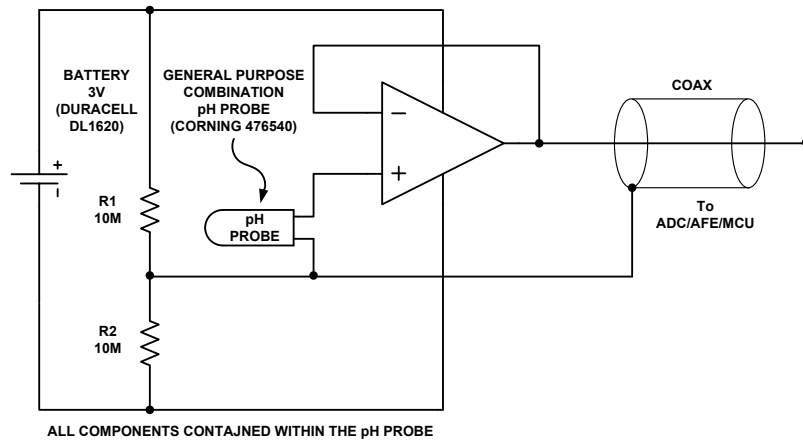

Figure 7: Buffer pH Probe

Two-Pole Micro-power Sallen-Key Low-Pass Filter

Figure 8 shows a micro-power two-pole Sallen-Key Low-Pass Filter with 400Hz cut-off frequency. For best results, the filter’s cut-off frequency should be 8 to 10 times lower than the OPA’s crossover frequency. Additional OPA’s phase margin shift can be avoided if the OPA’s bandwidth-to-signal ratio is greater than 8. The design equations for the 2-pole Sallen-Key low-pass filter are given below with component values selected to set a 400Hz low-pass filter cutoff frequency:

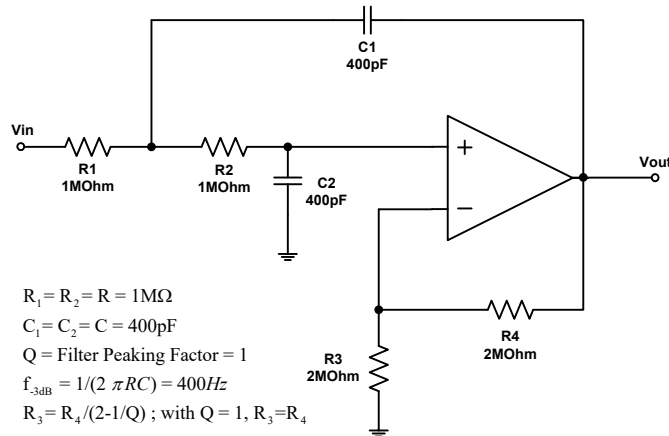

Figure 8

Portable Gas Sensor Amplifier

Gas sensors are used in many different industrial and medical applications. Gas sensors generate a current that is proportional to the percentage of a particular gas concentration sensed in an air sample. This output current flows through a load resistor and the resultant voltage drop is amplified. Depending on the sensed gas and sensitivity of the sensor, the output current can be in the range of tens of microamperes to a few milli-amperes. Gas sensor datasheets often specify a recommended load resistor value or a range of load resistors from which to choose.

There are two main applications for oxygen sensors – applications which sense oxygen when it is abundantly present (that is, in air or near an oxygen tank) and those which detect traces of oxygen in parts-per-million concentration. In medical applications, oxygen sensors are used when air quality or oxygen delivered to a patient needs to be monitored. In fresh air, the concentration of oxygen is 20.9% and air samples containing less than 18% oxygen are considered dangerous. In industrial applications, oxygen sensors are used to detect the absence of oxygen; for example, vacuum-packaging of food products.

The circuit in Figure 9 illustrates a typical implementation used to amplify the output of an oxygen detector. With the components shown in the figure, the circuit consumes less than 37µA of supply current ensuring that small form-factor single- or button-cell batteries (exhibiting low mAh charge ratings) could last beyond the operating life of the oxygen sensor. The precision specifications of these amplifiers, such as their low offset voltage, low TC-V_{OS},

low input bias current, high CMRR, and high PSRR are other factors which make these amplifiers excellent choices for this application.

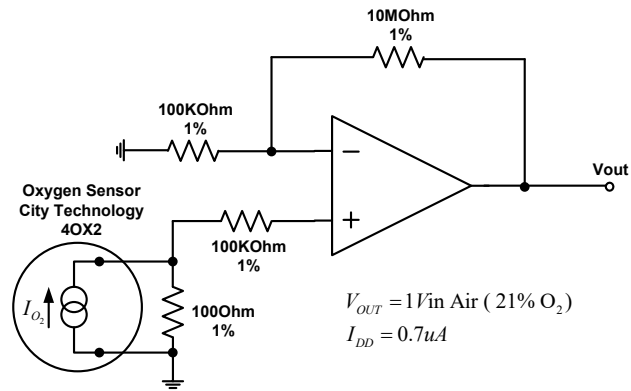
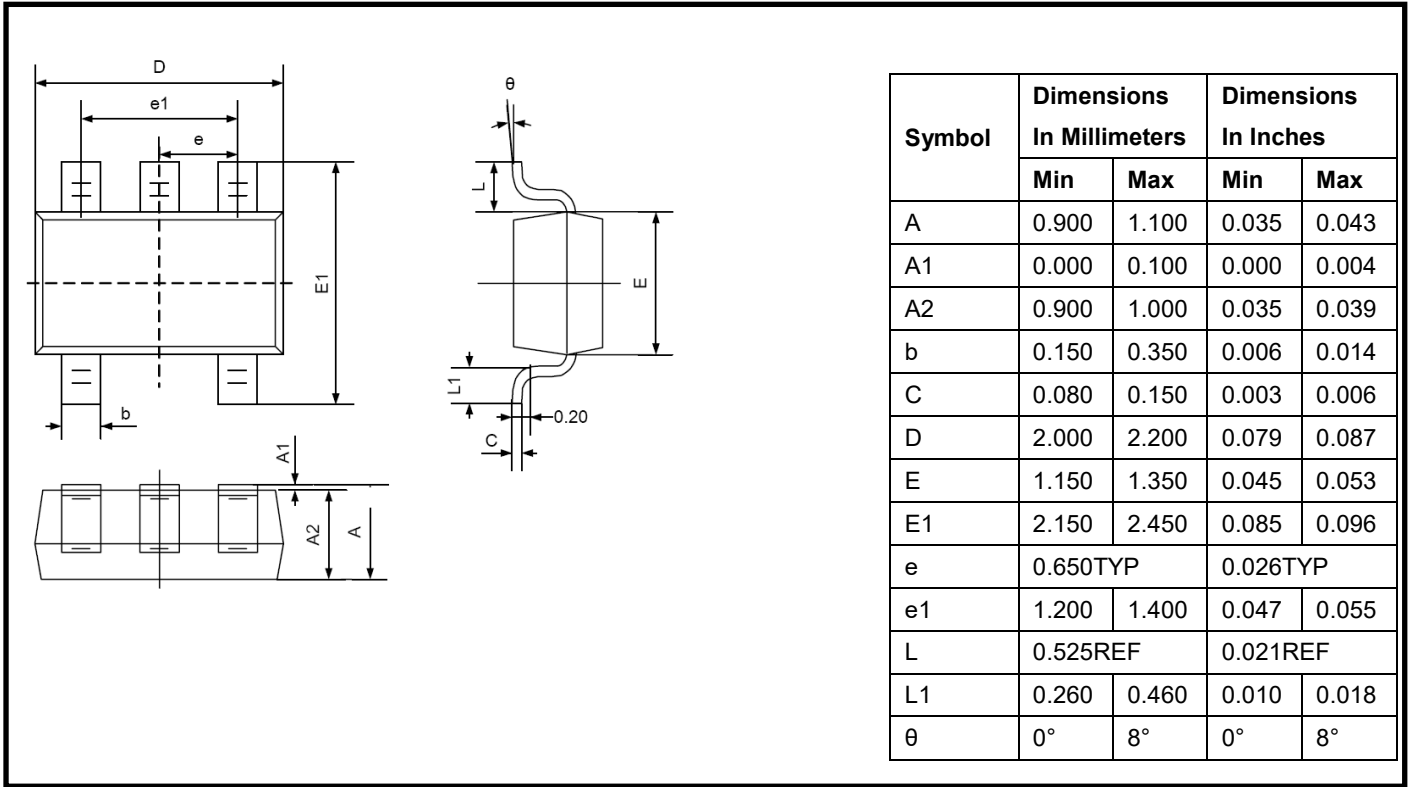

Figure 9

Package Outline Dimensions

SC70-5(SC70-6)



SOT23-5(SOT23-6)

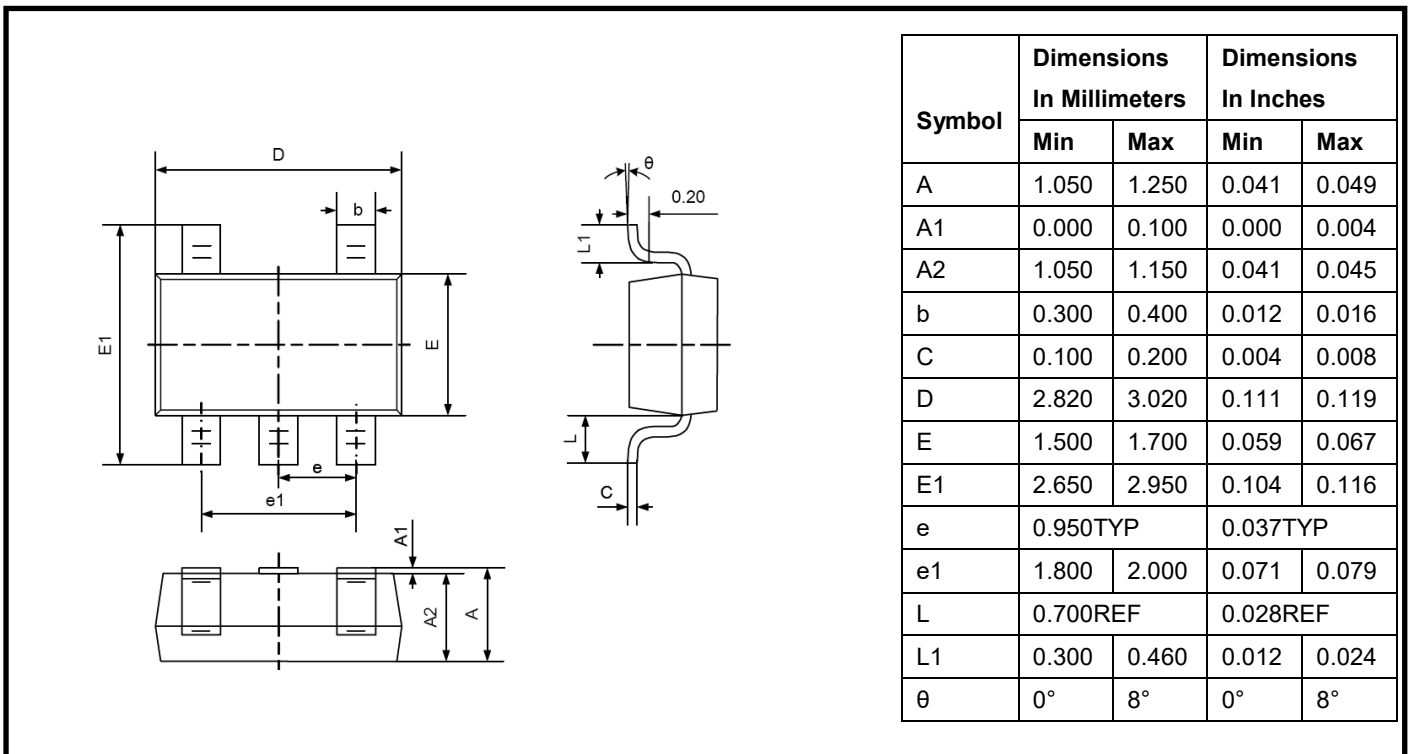

Package Outline Dimensions

SOIC-8

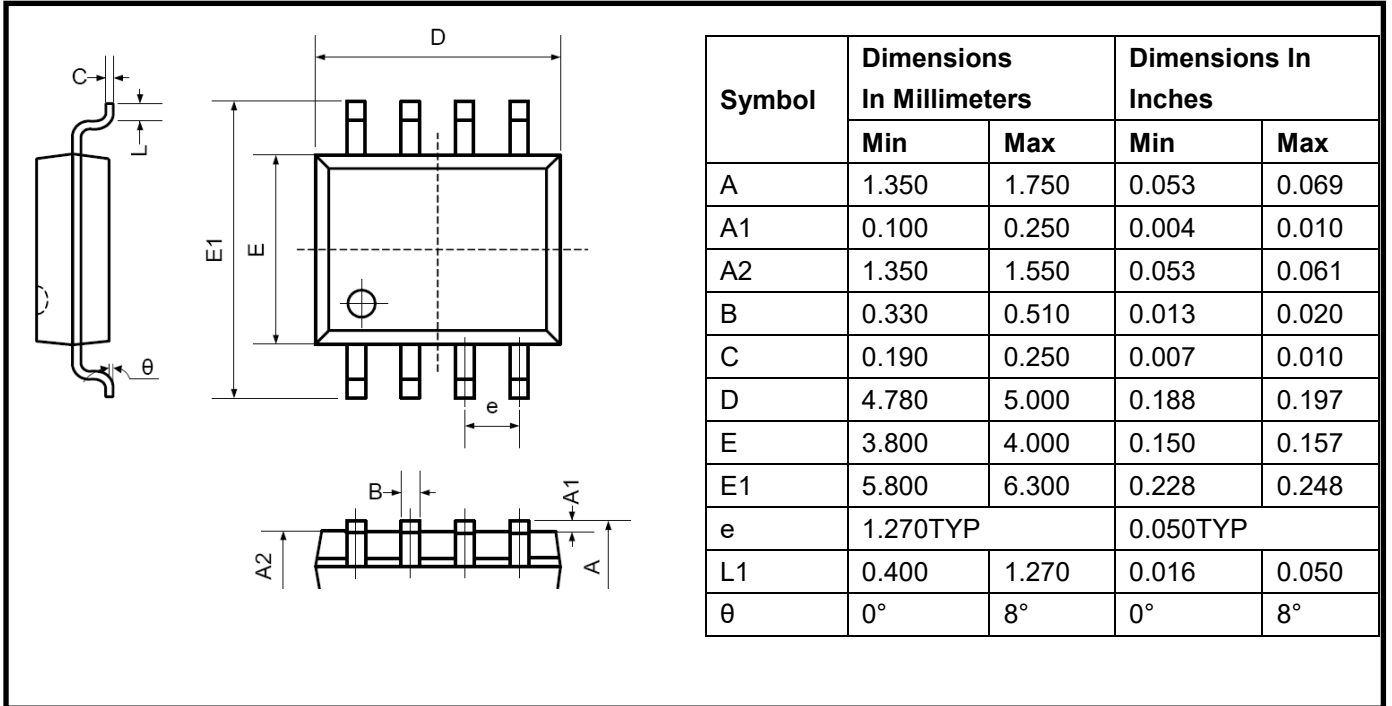

MSOP-8

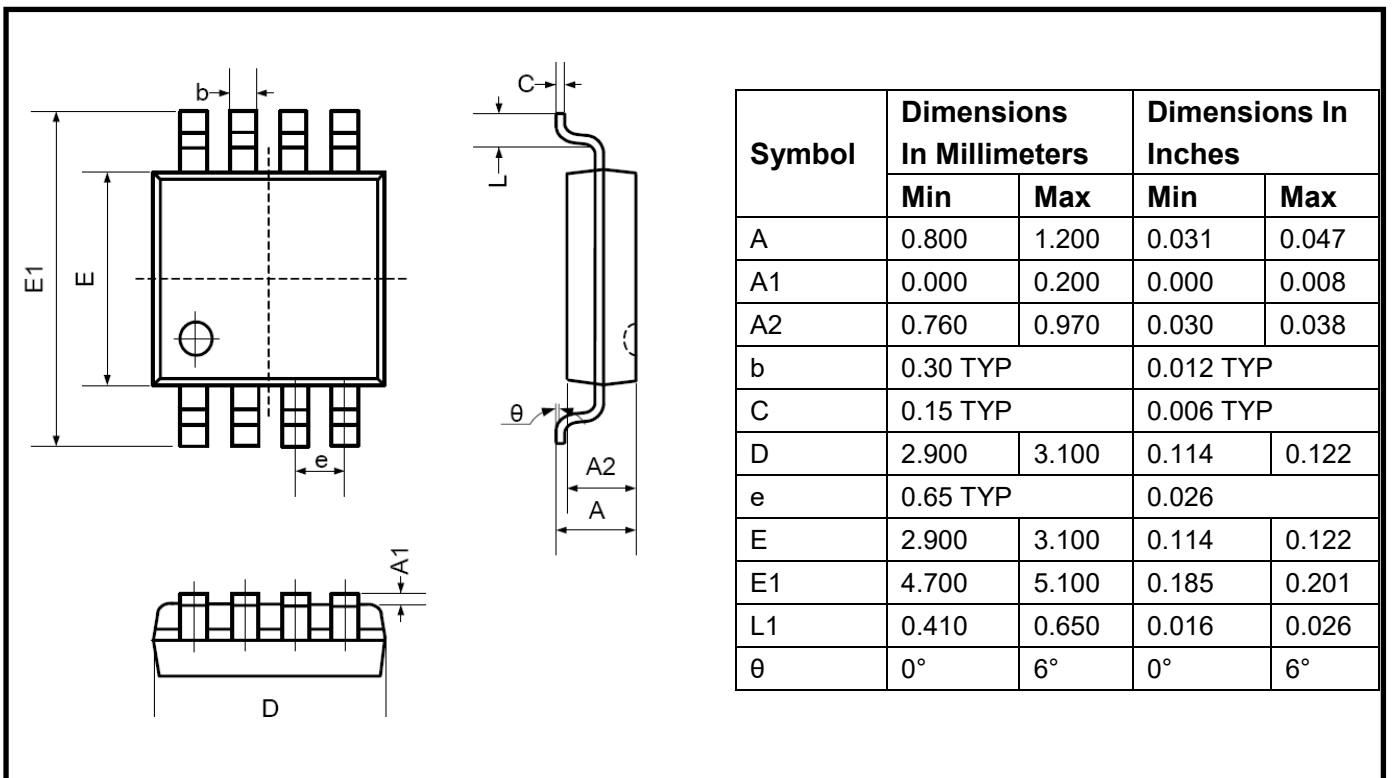

Package Outline Dimensions

DFN-8

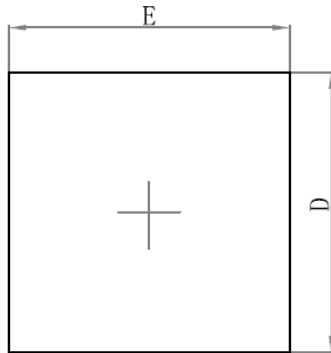

Top View

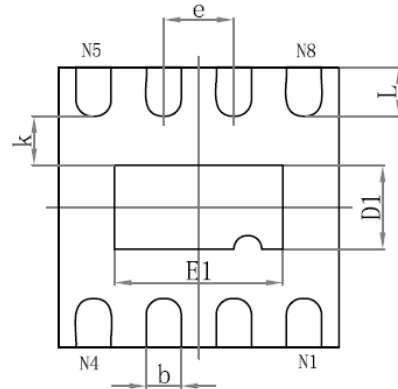

Bottom View

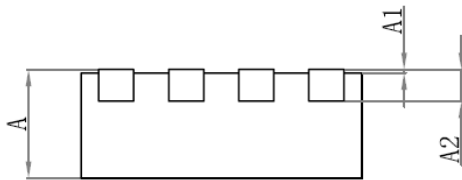

Side View

Symbol	Dimensions In Millimeters			Dimensions In Inches		
	Min	Nom	Max	Min	Nom	Max
A	0.80	0.85	0.9	0.031	0.033	0.035
A1	0.00	0.02	0.05	0.000	0.001	0.002
A2	0.153	0.203	0.253	0.006	0.008	0.010
b	0.18	0.24	0.30	0.007	0.009	0.012
D	1.9	2.0	2.1	0.075	0.079	0.083
E	1.9	2.0	2.1	0.075	0.079	0.083
D1	0.5	0.6	0.7	0.020	0.024	0.028
E1	1.1	1.2	1.3	0.043	0.047	0.051
e		0.50			0.20	
k	0.2			0.008		
L	0.25	0.35	0.45	0.010	0.014	0.018

Package Outline Dimensions

SOIC-14

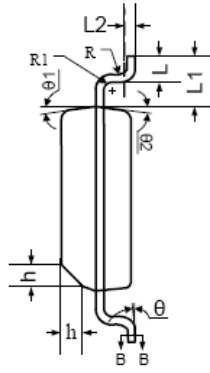
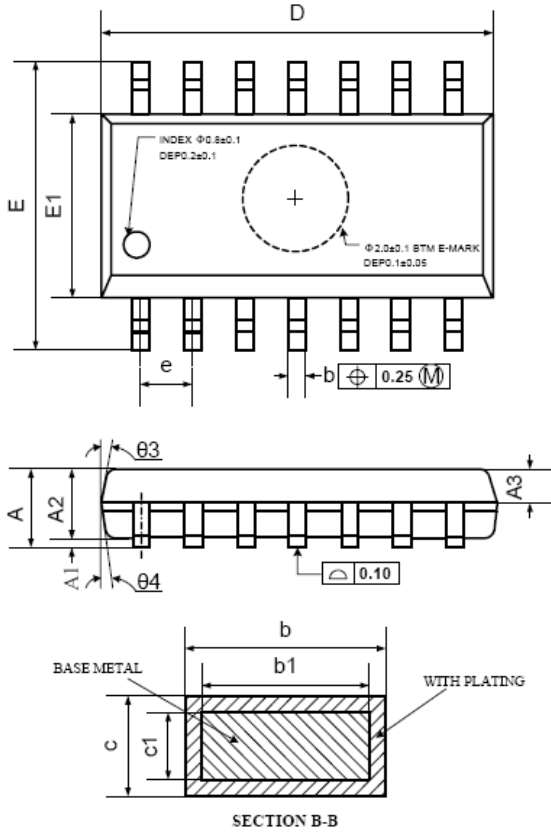

Symbol	Dimensions In Millimeters		
	MIN	NOM	MAX
A	1.35	1.60	1.75
A1	0.10	0.15	0.25
A2	1.25	1.45	1.65
A3	0.55	0.65	0.75
b	0.36		0.49
b1	0.35	0.40	0.45
c	0.16		0.25
c1	0.15	0.20	0.25
D	8.53	8.63	8.73
E	5.80	6.00	6.20
E1	3.80	3.90	4.00
e	1.27 BSC		
L	0.45	0.60	0.80
L1	1.04 REF		
L2	0.25 BSC		
R	0.07		
R1	0.07		
h	0.30	0.40	0.50
θ	0°		8°
θ_1	6°	8°	10°
θ_2	6°	8°	10°
θ_3	5°	7°	9°
θ_4	5°	7°	9°

TP1541A/TP1541NA/TP1542A/TP1544A

Stable 1.3MHz, Precision, RRIO, Op Amps

Package Outline Dimensions

TSSOP-14

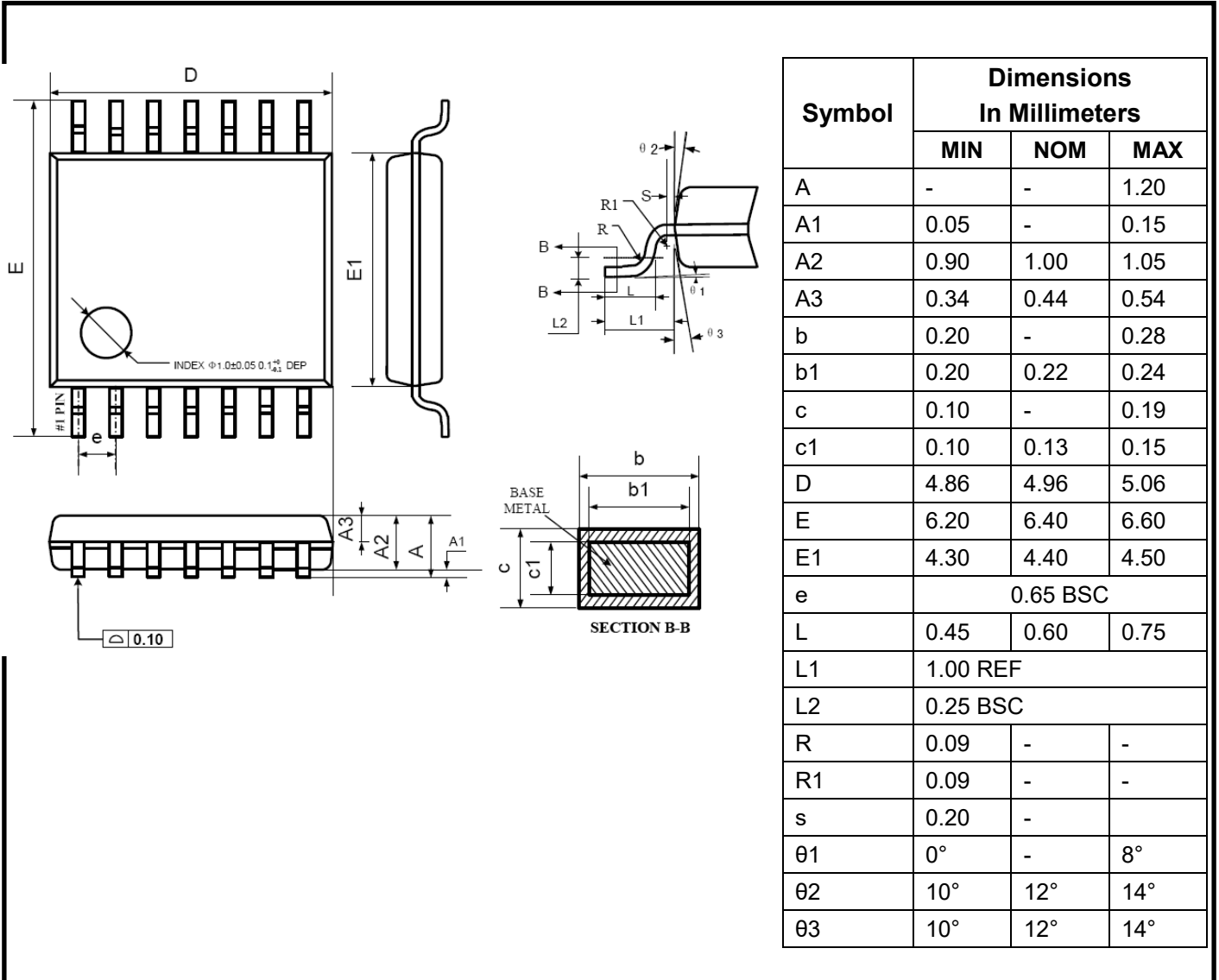

X-ON Electronics

Largest Supplier of Electrical and Electronic Components

Click to view similar products for [Operational Amplifiers - Op Amps](#) category:

Click to view products by [3PEAK](#) manufacturer:

Other Similar products are found below :

[LM358SNG](#) [430227FB](#) [AZV831KTR-G1](#) [UPC824G2-A](#) [LT1678IS8](#) [042225DB](#) [058184EB](#) [SC2902DG](#) [UPC822G2-A](#) [UPC258G2-A](#)
[NCS5651MNTXG](#) [NCV33202DMR2G](#) [NJM324E](#) [NTE925](#) [5962-9080901MCA*](#) [AP4310AUMTR-AG1](#) [HA1630D02MMEL-E](#)
[HA1630S01LPEL-E](#) [SCY33178DR2G](#) [NJU77806F3-TE1](#) [NCV5652MUTWG](#) [NCV20034DR2G](#) [LM2902EDR2G](#) [NTE778S](#) [NTE871](#)
[NTE924](#) [NTE937](#) [MCP6V16UT-E/OT](#) [MCP6V17T-E/MS](#) [MCP6V19T-E/ST](#) [SCY6358ADR2G](#) [LTC2065IUD#PBF](#) [NCS20282FCTTAG](#)
[UPC4741G2-E1-A](#) [LM4565FVT-GE2](#) [EL5420CRZ-T7A](#) [TSV791IYLT](#) [TSV772IQ2T](#) [AS324AMTR-E1](#) [TLV2772QPWR](#) [NJM4556AM-](#)
[TE1](#) [NJM2068M-TE1](#) [AS324MTR-E1](#) [AS358MMTR-G1](#) [MCP6232T-EMNY](#) [MCP662-E/MF](#) [TLC081AIP](#) [TLC082AIP](#) [TLE2074ACDW](#)
[TLV07IDR](#)