

Features

- Excellent DC specifications
 - ◆ **Small voltage offset: $\pm 50\mu\text{V}$ (MAX)**
 - ◆ **Small voltage offset drift: $0.2\mu\text{V}/^\circ\text{C}$ (MAX)**
 - ◆ **Small input bias current: 1.5nA (MAX)**
- Excellent AC specifications
 - ◆ **CMRR: 80dB @ G=1 (MIN)**
 - ◆ **Small input noise: $15\text{nV}/\sqrt{\text{Hz}}$ @ G=10**
 - ◆ **Input noise (0.1 Hz to 10 Hz): $1\mu\text{V}$ p-p**
 - ◆ **-3dB Bandwidth: 1.6MHz**
 - ◆ **Slew rate: 5V/us**
- Gain set with 1 external resistor (gain range 1 to 1,000)
- SUPPLY VOLTAGE: **$\pm 2\text{V}$ to $\pm 18\text{V}$**
- RAIL to RAIL for VOLTAGE OUTPUT
- Operating Temperature: -45°C to $+125^\circ\text{C}$
- SOP8, MSOP8 & DFN3X3-8 PACKAGE

Applications

- Weigh scales for bridge amplifiers
- Medical and ECG Amplifiers
- Industrial Process Control
- Precision data acquisition system
- Pressure sensors

- Precision current measurement

Description

The TPA1286 is a low cost, wide supply range instrumentation amplifier that requires only one external resistor to set any gain between 1 and 1,000. The TPA1286 is designed to work with a variety of single voltages. A wide input range and rail-to-rail output allow the signal to make full use of the supply rails. Low voltage offset, low offset drift, low gain drift, high gain accuracy, and high CMRR make this part an excellent choice in applications that demand the best DC performance.

The TPA1286 operates from single 4V to 36V supply, offers breakthrough performance throughout the -40°C to $+125^\circ\text{C}$ temperature range. It features a zero-drift core, which leads to a typical offset drift of $0.2\mu\text{V}/^\circ\text{C}$ throughout the operating temperature range.

TPA1286 is available in SOP8, MSOP8 and DFN3X3-8 package.

Table of Contents

Features	1
Applications	1
Description	1
Revision History	2
Pin Configuration	3
Order Information	4
Absolute Maximum Ratings ^{Note 1}	4
ESD, Electrostatic Discharge Protection	4
Thermal Resistance	4
Electrical Characteristics	5
Typical Performance Characteristics	7
Operation Overview	14
Applications Information	14
TPA1286 Application block diagram	14
Selecting GAIN Resistor	14
REFERENCE INPUT PIN	14
Power Supply Recommendation	15
Proper Board Layout	15
TAPE AND REEL INFORMATION	16
Package Outline Dimensions	17
SOIC-8	17
MSOP8	18
DFN3X3-8	19
IMPORTANT NOTICE AND DISCLAIMER	20

Revision History

Date	Revision	Notes
2020/2/5	Rev.Pre.0	Initial Version.
2020/12/25	Rev.A.0	Released version.
2021/3/30	Rev.A.1	Added DFN3X3-8 package.
2022/5/1	Rev.A.2	Updated package outline dimensions.
2024/1/11	Rev.A.3	Added figure 31 to 38: Input Common-Mode Range vs. Output Voltage.

Pin Configuration

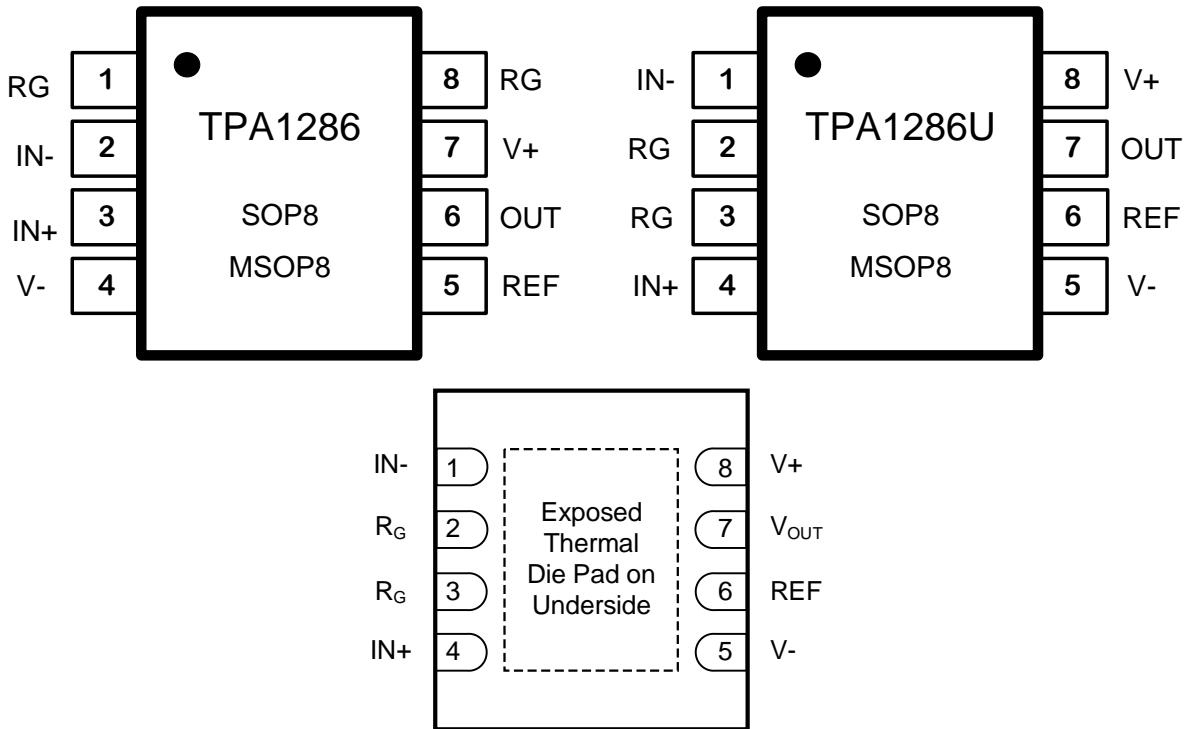

PIN NAME	TPA1286 DESCRIPTION
IN-	Negative Input
IN+	Positive Input.
RG	Gain setting
VREF	Reference Input.
OUT	Output
V+	Positive power supply
V-	Negative power supply
Thermal pad	Exposed thermal die pad is internally connected to -Vs. Connect externally to -Vs or leave floating.

Order Information

Model Name	Order Number	Package	Transport Media, Quantity	Package Marking
TPA1286	TPA1286-SO1R	8-Pin SOP8	Tape and Reel, 4,000	1286
	TPA1286U-SO1R	8-Pin SOP8	Tape and Reel, 4,000	1286U
	TPA1286-VS1R	8-Pin MSOP8	Tape and Reel, 3,000	1286
	TPA1286U-VS1R	8-Pin MSOP8	Tape and Reel, 3,000	1286U
	TPA1286U-DF7R	8-Pin DFN3X3	Tape and Reel, 4,000	286U

Absolute Maximum Ratings ^{Note 1}

Supply Voltage	40V	Operating Temperature Range.....	-40°C to 125°C
Input Voltage.....(V-) – 0.3 to (V+) + 0.3V		Maximum Working Junction Temperature.....	150°C
Differential Input Voltage	(V+) – (V-)	Storage Temperature Range.....	-65°C to 150°C
Input Current: IN+, IN- ^{Note 2}	±10mA	Lead Temperature (Soldering, 10 sec)	260°C

Note 1: Stresses beyond those listed under Absolute Maximum Ratings may cause permanent damage to the device. Exposure to any Absolute Maximum Rating condition for extended periods may affect device reliability and lifetime.

Note 2: The inputs are protected by ESD protection diodes to power supply.

ESD, Electrostatic Discharge Protection

Symbol	Parameter	Condition	Minimum Level	Unit
HBM	Human Body Model ESD	ANSI/ESDA/JEDEC JS-001	3	kV
CDM	Charged Device Model ESD	ANSI/ESDA/JEDEC JS-002	1.5	kV

Thermal Resistance

Package Type	θ_{JA}	θ_{JC}	Unit
8-Pin SOP8	158	43	°C/W
8-Pin MSOP8	210	45	°C/W
DFN3X3-8	51	60	°C/W

Electrical Characteristics

The specifications are at TA = 25°C, V+ = +15V, V- = -15V, REF = 0V, unless otherwise noted

Symbol	Parameter	Conditions	Min	Typ	Max	Unit
INPUT						
V _{OSI}	Input Stage Offset Voltage	At RTI		±10	±50	μV
		At RTI, -40°C to 125°C		±0.1	±0.2	μV/°C
V _{OSO}	Output Stage Offset Voltage	At RTI		±100	±300	μV
		At RTI, -40°C to 125°C		±0.2	±0.3	μV/°C
V _{OS}	Offset Voltage	At RTI		±10 ±100/G	±50 ±300/G	μV
V _{OS TC}	Input Offset Voltage Drift	-40°C to 125°C			±0.2 ±0.3/G	μV/°C
V _{CM}	Common-mode Input Range	-40°C to 125°C	(V-) +0.1		(V+) - 1.5	V
CMRR	Common Mode Rejection Ratio	CMRR at DC, G=1	80	100		dB
		CMRR at DC, G=10	100	120		dB
		CMRR at DC, G=100	110	130		
		CMRR at DC, G=1000	120	140		
I _b	Input Bias Current			0.3	1.5	nA
		-40°C to 125°C		10		pA/°C
I _{os}	Input Offset Current			0.3	1.5	nA
		-40°C to 125°C		10		pA/°C
Input impedance	Input impedance	Differential		57 6		GΩ pF
		Common mode		44 14		GΩ pF
PSRR	Power Supply Rejection Ratio	G=1	100	120		dB
		G=10	110	130		dB
		G=100	120	138		dB
		G=1000	130	140		dB
RIN	Reference input			20		kΩ
NOISE RTI						
e _n	Input Voltage Noise Density	f = 1kHz, G=10		15		nV/√Hz
		f = 0.1Hz to 10Hz, G=1		1		μV p-p
OUTPUT						
G	G = 1 + (49.4 kΩ/RG)		1		1000	V/V
GE	Gain Error	G=1		±0.01%	±0.05%	
		G=10		±0.1%	±0.15%	
		G=100		±0.1%	±0.2%	
		G=1000		±0.3%	±0.6%	
G TC	Gain Vs Temperature	-40°C to 125°C, G=1		1	5	ppm/°C

High Voltage, Precision, Zero-drift, Instrumentation Amplifier

Symbol	Parameter	Conditions	Min	Typ	Max	Unit
I _{SC}	Short circuit current	-40°C to 125°C		±70		mA
V _{OH}	Output Swing from Supply Rail	-40°C to 125°C, R _L = 10 kΩ		0.12	0.2	V
V _{OL}	Output Swing from Supply Rail	-40°C to 125°C, R _L = 10 kΩ		0.05	0.1	V
FREQUENCY RESPONSE						
BW	-3dB Bandwidth	G=1		1600		kHz
		G=10		400		kHz
		G=100		100		kHz
		G=1000		11		kHz
ST	Setting time to 0.01%	G=1		2.1		μs
SR	Slew Rate	G=1		5		V/μs
		G=100		2.5		V/μs
POWER SUPPLY						
V+	Supply Voltage		±2		±18	V
I _Q	Quiescent Current			3.8	4.5	mA
TEMPERATURE RANGE						
	Specified range		-40		125	°C

Typical Performance Characteristics

The TPA1286 is used for characteristics at TA = 25°C, Vs = ±15V, RL = 10 kΩ, unless otherwise noted.

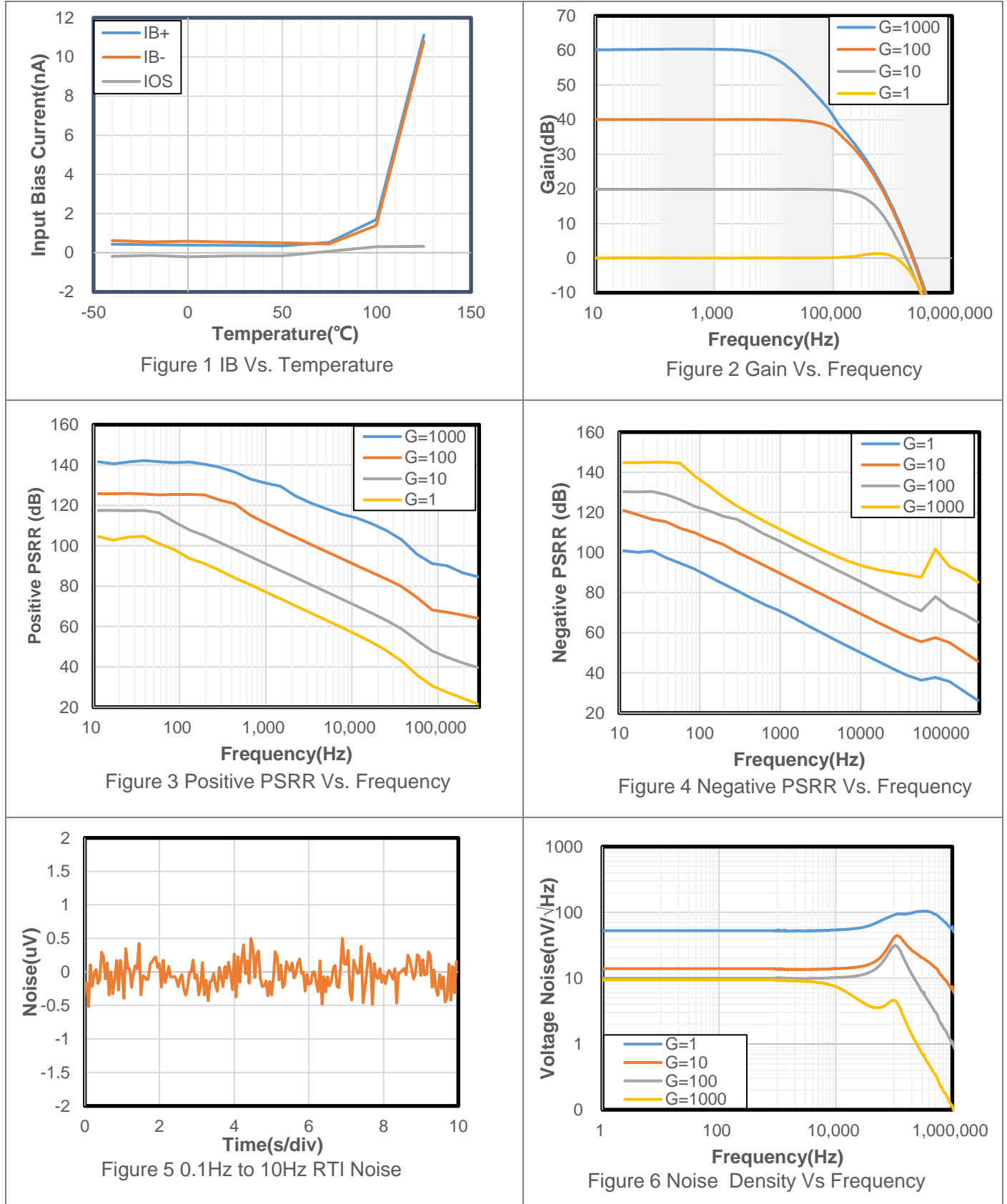

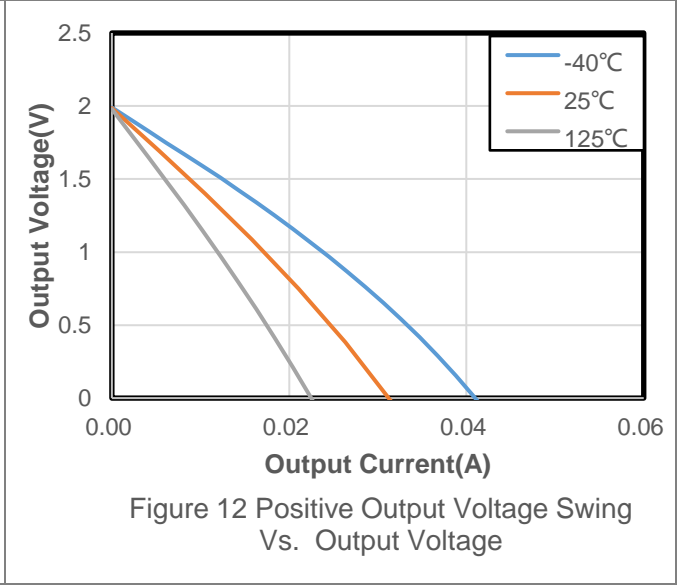
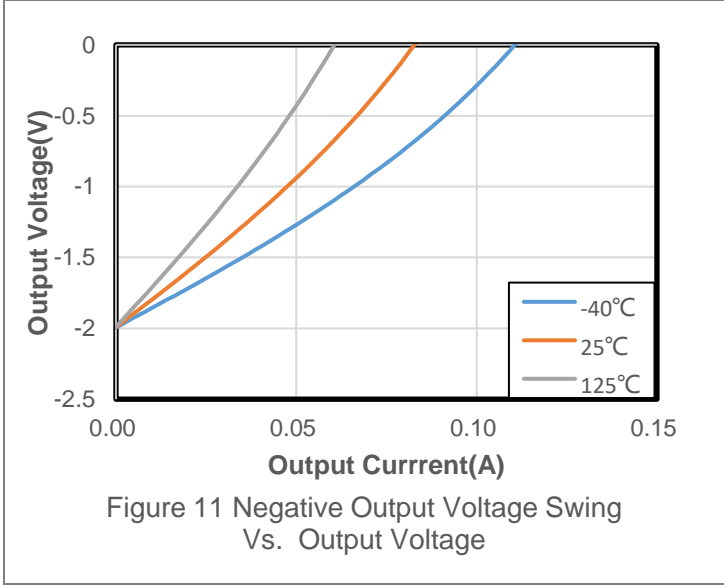
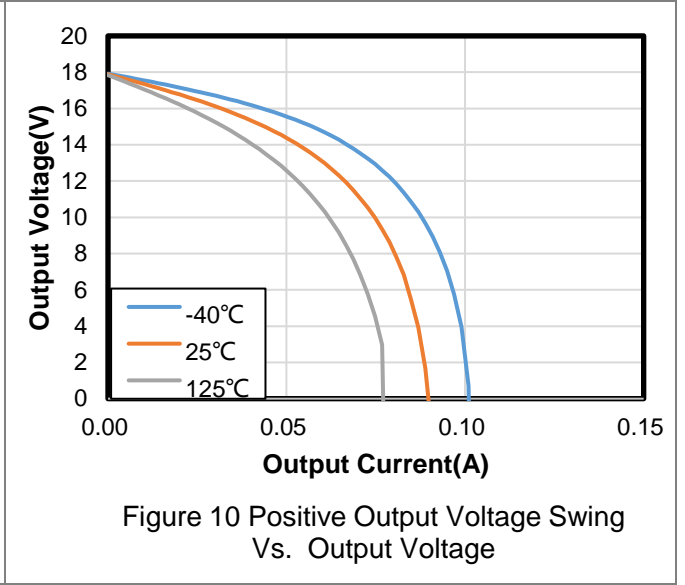
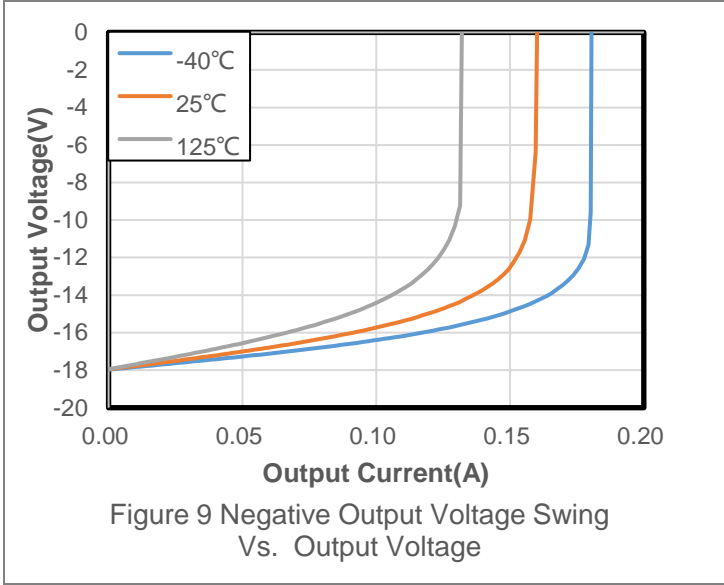
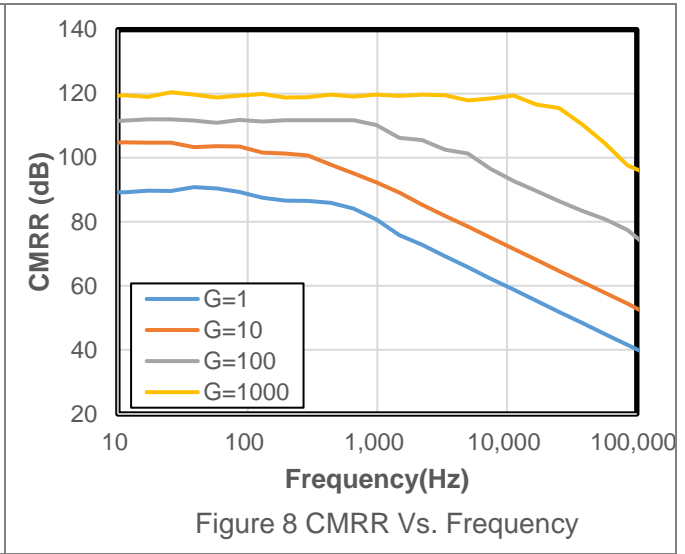
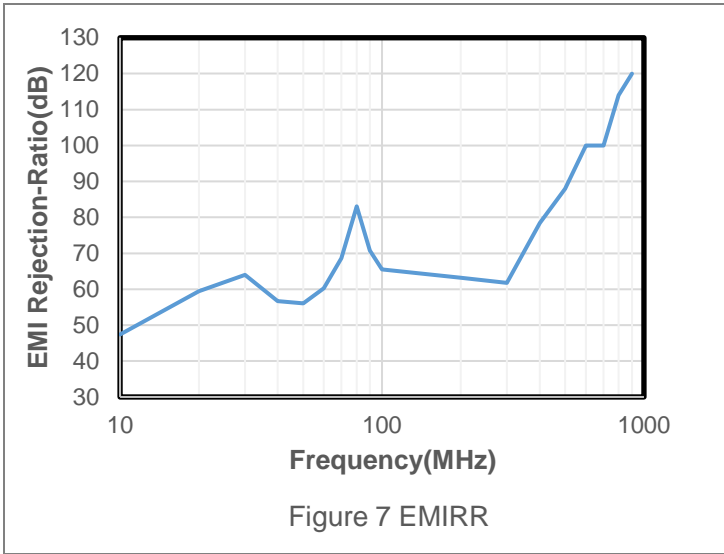

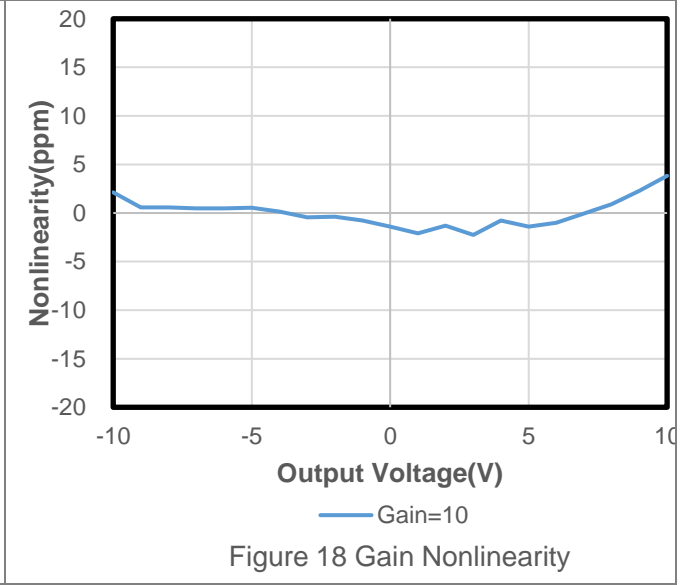
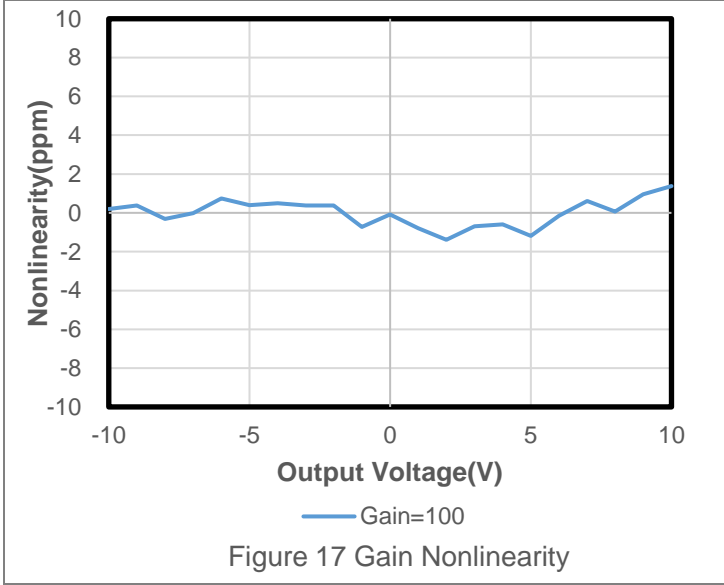
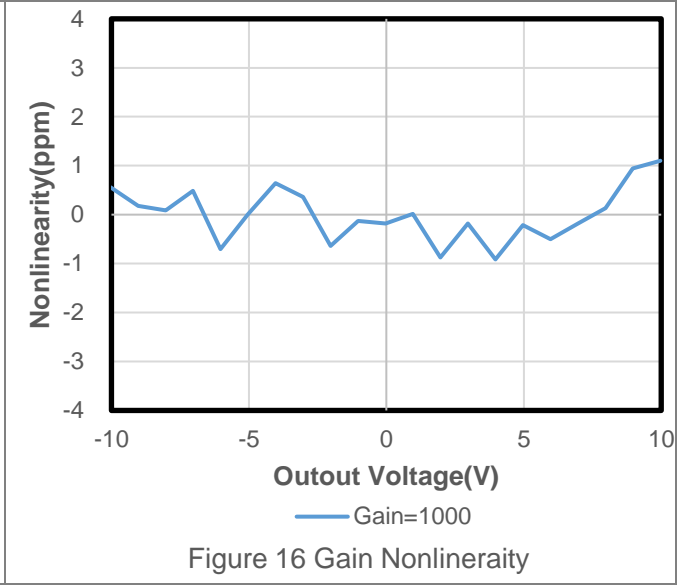
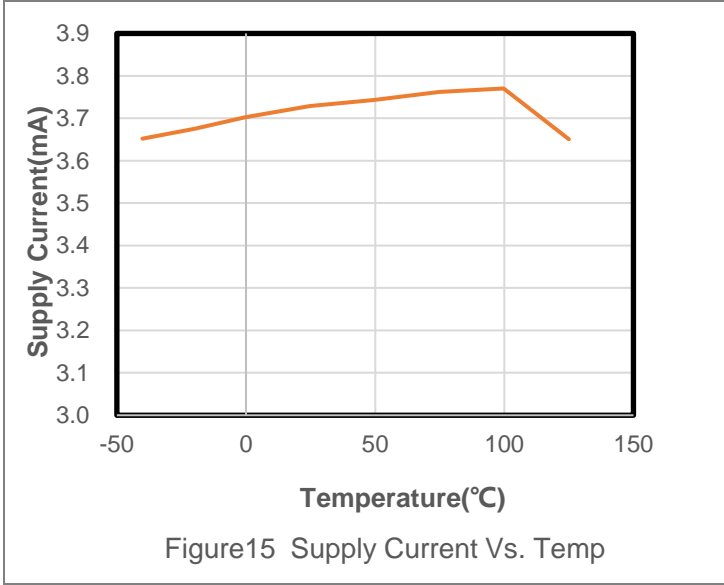
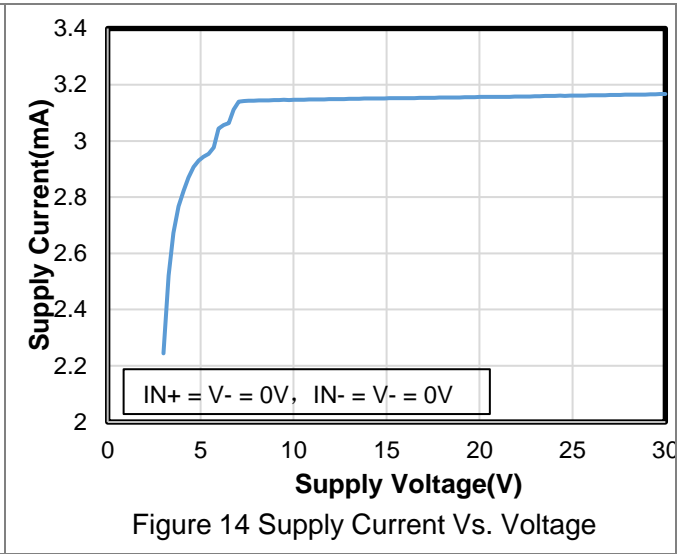
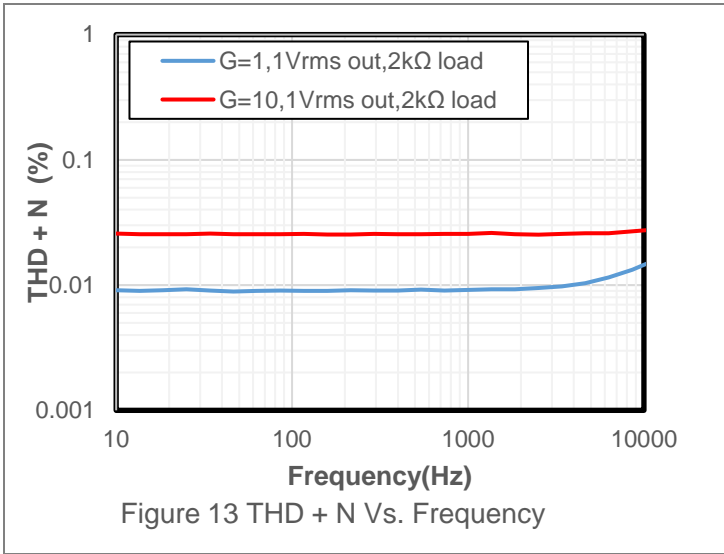

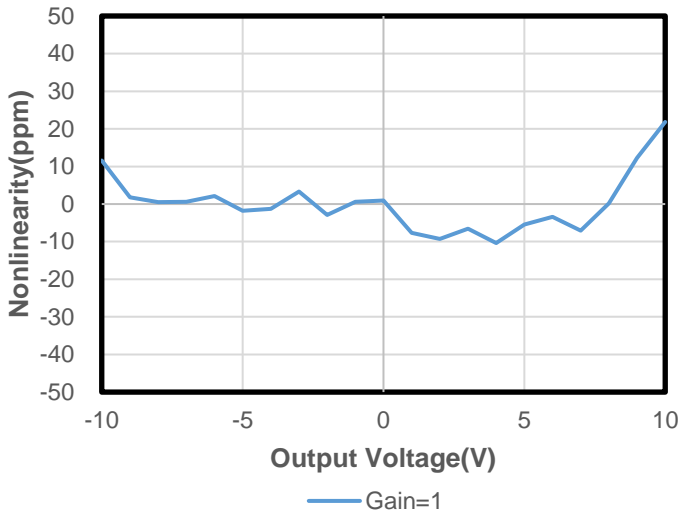

Figure 19 Gain Nonlinearity



Voltage: 2V/div for Output, Time: 10us/div G=1, VREF = GND; VIN=10VPP, Load R=10K
Figure 20 Slew Rate



Voltage: 5V/div for Output, Time: 2us/div G=10, VREF = GND; VIN=10VPP, Load R=10K C=100pF
Figure 21 Positive Overload Recovery



Voltage: 5V/div for Output, Time: 2us/div G=10, VREF = GND; VIN=10VPP, Load R=10K C=100pF
Figure 22 Negative Overload Recovery



Voltage: 2V/div for Output, Time: 10us/div G=1, VREF = GND; VIN=10VPP, Load R=10K C=100pF
Figure 23 Large-Signal Pulse Response



Voltage: 2V/div for Output, Time: 20us/div G=10, VREF = GND; VIN=1VPP, Load R=10K C=100pF
Figure 24 Large-Signal Pulse Response



Voltage: 2V/div for Output, Time: 20us/div G=100, VREF = GND;
VIN=0.1VPP, Load R=10K C=100pF
Figure 25 Large-Signal Pulse Response



Voltage: 2V/div for Output, Time: 50us/div G=1000, VREF = GND;
VIN=10mVPP, Load R=10K C=100pF
Figure 26 Large-Signal Pulse Response



Voltage: 25mV/div for Output, Time: 10us/div G=1, VREF = GND;
VIN=100mVPP, Load R=10K C=100pF
Figure 27 Small-Signal Pulse Response

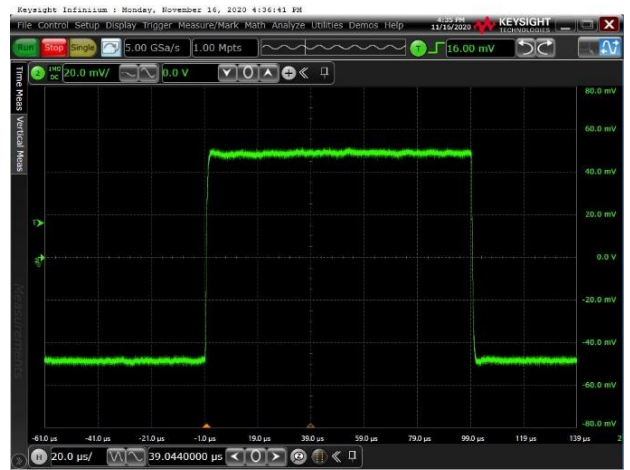

Voltage: 20mV/div for Output, Time: 20us/div G=10, VREF = GND;
VIN=10mVPP, Load R=10K C=100pF
Figure 28 Small-Signal Pulse Response



Voltage: 50mV/div for Output, Time: 20us/div G=100, VREF = GND;
VIN=2mVPP, Load R=10K C=100pF
Figure 29 Small-Signal Pulse Response



Voltage: 500mV/div for Output, Time: 50us/div G=10, VREF = GND;
VIN=2mVPP, Load R=10K C=100pF
Figure 30 Small-Signal Pulse Response

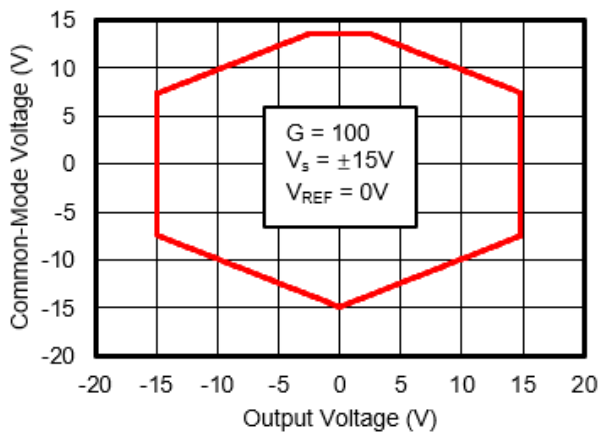

Figure 31 Input Common-Mode Range vs. Output Voltage

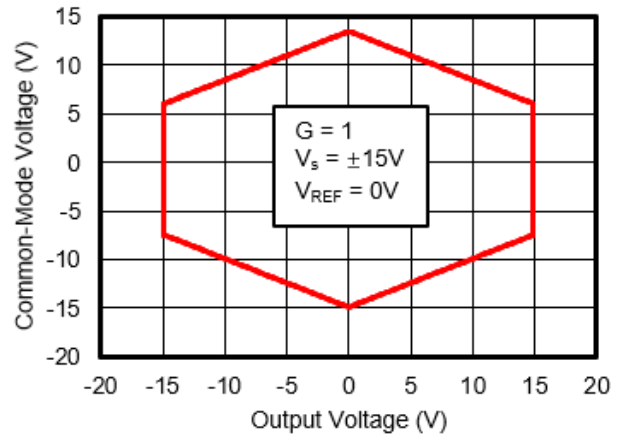

Figure 32 Input Common-Mode Range vs. Output Voltage

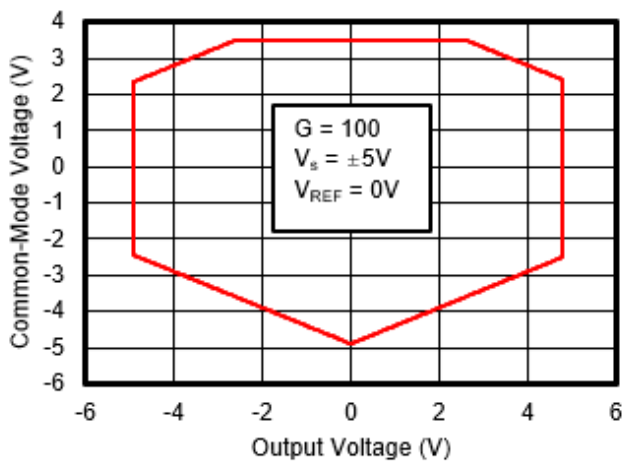

Figure 33 Input Common-Mode Range vs. Output Voltage

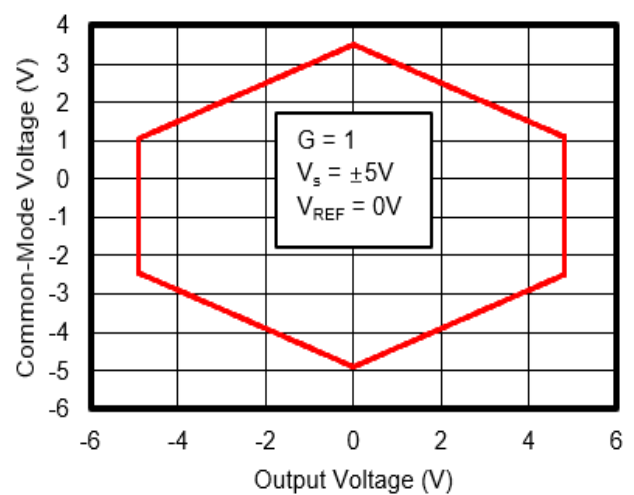

Figure 34 Input Common-Mode Range vs. Output Voltage

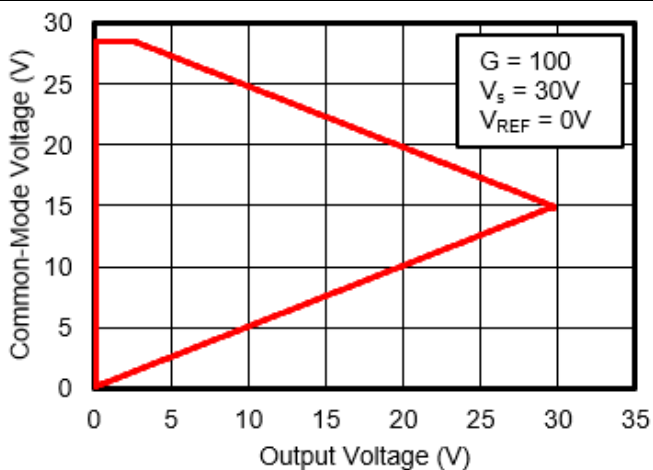

Figure 35 Input Common-Mode Range vs. Output Voltage

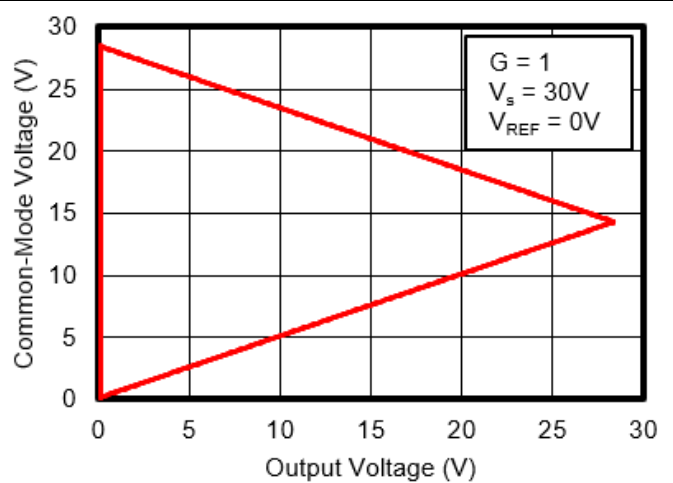

Figure 36 Input Common-Mode Range vs. Output Voltage

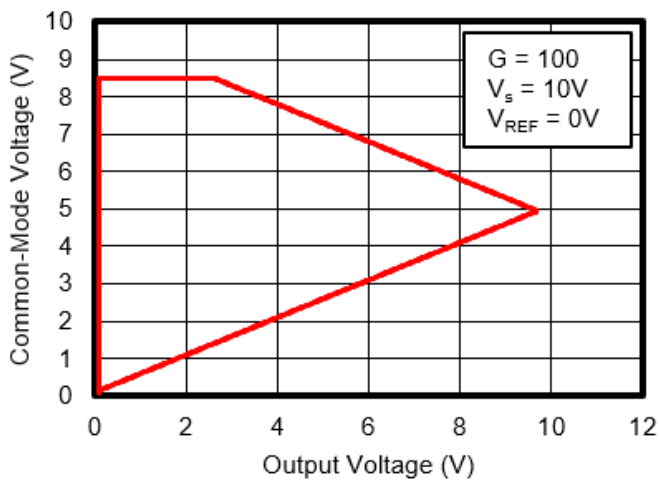

Figure 37 Input Common-Mode Range vs. Output Voltage

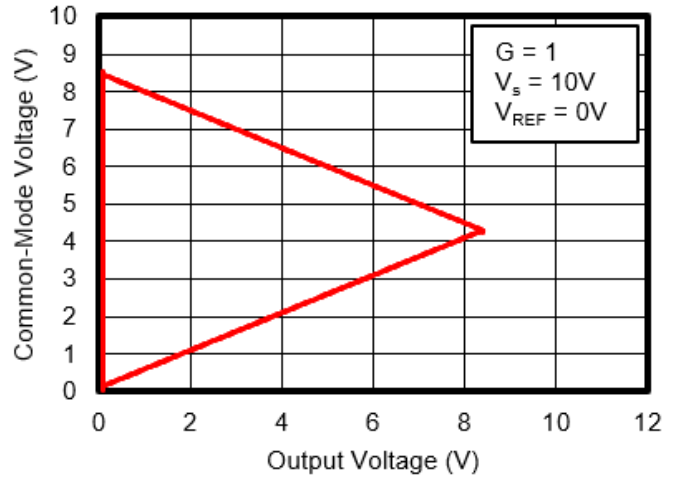

Figure 38 Input Common-Mode Range vs. Output Voltage

Operation Overview

The TPA1286 is a monolithic instrumentation amplifier (INA) based on the high voltage, precision zero-drift OPA core, and classic 3-op amp topology. The TPA1286 also integrates precision resistors to ensure excellent common mode rejection and low gain error. The combination of the zero-drift amplifier core and the precision resistors allows this device to achieve outstanding dc precision and makes the TPA1286 ideal for many high-voltage industrial applications.

A unique pinout of the TPA1286U enable to meet a good CMRR specification. The balanced pinout reduces the parasitic that had adversely affected CMRR performance. In addition, this pinout simplifies board layout because associated traces are grouped together. For example, the gain setting resistor pins are adjacent to the inputs, and the reference pin is next to the output.

Applications Information

TPA1286 Application block diagram

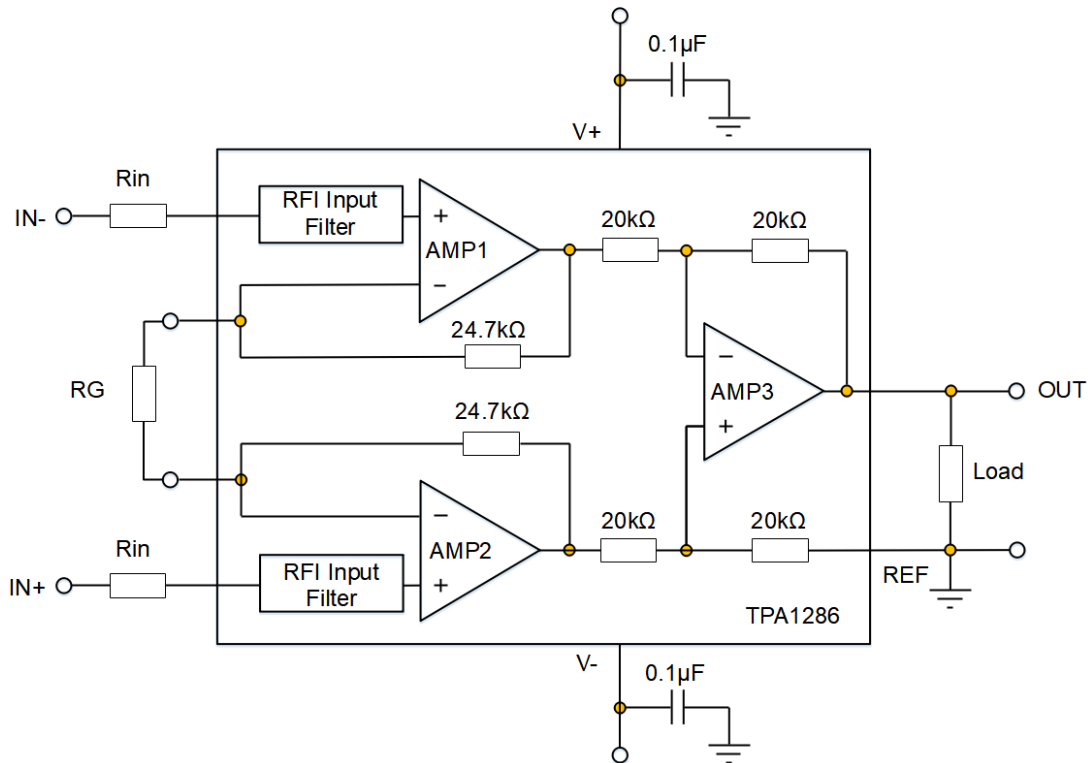

Selecting GAIN Resistor

The gain of the TPA1286 is set by a single external resistor, RG, connected between RG pins. The value of RG is selected according to below Equation. TPA1286 can be set as G = 1 when no gain resistor is used. Gain accuracy is determined by the accuracy of RG. The stability and temperature drift of the external gain setting resistor, RG, also affects gain. The contribution of RG to gain accuracy and drift can be determined from below equation.

$$G = 1 + \frac{49.4k}{RG}$$

REFERENCE INPUT PIN

High Voltage, Precision, Zero-drift, Instrumentation Amplifier

As shown in above Figure, the reference pin, REF, is connected with a 20 k Ω resistor. The output of the instrumentation amplifier is referenced to the voltage on the REF pin; this is useful when the output signal needs to be offset to a precise mid-supply level. For example, a voltage source can be tied to the REF pin to level-shift the output so that the TPA1286 can interface with an ADC. For best performance, source impedance to the REF pin should be kept as low as possible, because parasitic resistance can adversely affect CMRR and gain accuracy. PCB Layout should be very careful to tie REF to the appropriate local cleaning ground.

Power Supply Recommendation

A stable and cleaning dc voltage should be used to be as power supply of the instrumentation amplifier, which noise on the supply pins can affect performance. Bypass capacitors should be used to decouple the amplifier. A 0.1 μ F capacitor should be placed close to each supply pin.

Proper Board Layout

To maximizes system performance, careful board layout is needed. Traces from the gain setting resistor to the RG pins should be kept as short as possible to minimize parasitic inductance. To ensure the most accurate output, the trace from the REF pin should either be connected to the local ground of the TPA1286, or connected to a voltage that is referenced to the local ground of the TPA1286

TAPE AND REEL INFORMATION

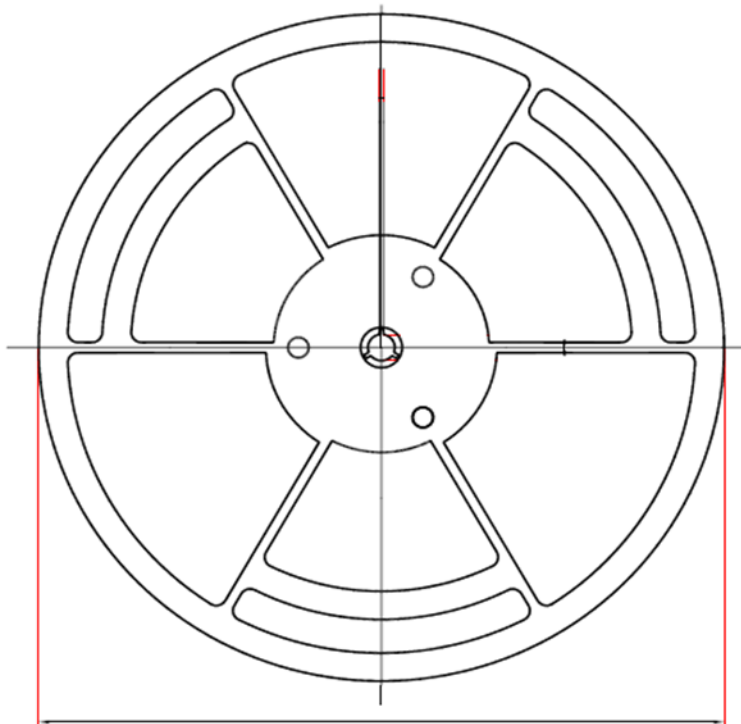

D1: Reel Diameter

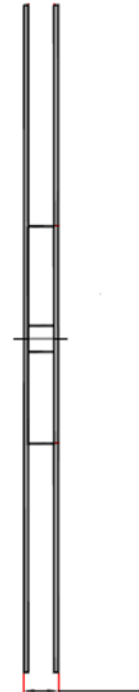

W1: Reel Width

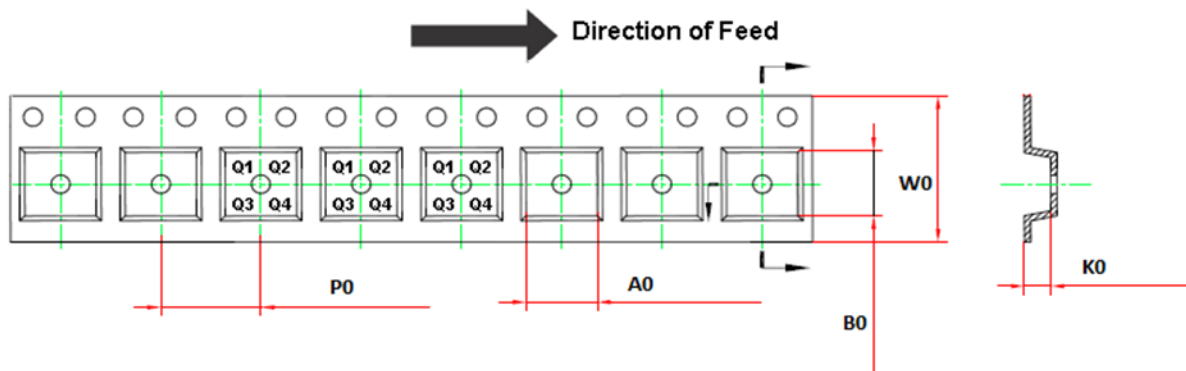

Order Number	Package	D1 (mm)	W1 (mm)	A0 (mm)	B0 (mm)	K0 (mm)	P0 (mm)	W0 (mm)	Pin1 Quadrant
TPA1286-SO1R	8-Pin SOP	330.0	17.6	6.4	5.4	2.1	8.0	12.0	Q1
TPA1286U-SO1R	8-Pin SOP	330.0	17.6	6.4	5.4	2.1	8.0	12.0	Q1
TPA1286-VS1R	8-Pin MSOP	330.0	17.6	5.2	3.3	1.5	8.0	12.0	Q1
TPA1286U-VS1R	8-Pin MSOP	330.0	17.6	5.2	3.3	1.5	8.0	12.0	Q1
TPA1286U-DF7R	DFN3X3-8	330.0	16.8	3.3	3.3	1.1	8.0	12.0	Q2

Package Outline Dimensions

SOIC-8

Package Outline Dimensions

SO1(SOP-8-A)

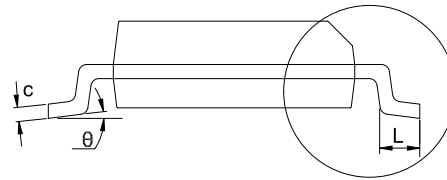
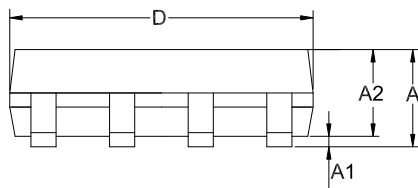
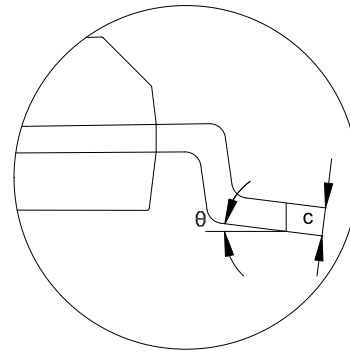
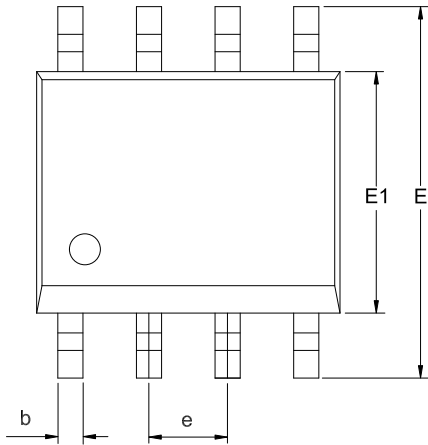

Symbol	Dimensions In Millimeters		Dimensions In Inches	
	MIN	MAX	MIN	MAX
A	1.350	1.750	0.053	0.069
A1	0.050	0.250	0.002	0.010
A2	1.250	1.550	0.049	0.061
b	0.330	0.510	0.013	0.020
c	0.170	0.250	0.007	0.010
D	4.700	5.100	0.185	0.201
E	5.800	6.200	0.228	0.244
E1	3.800	4.000	0.150	0.157
e	1.270 BSC		0.050 BSC	
L	0.400	1.000	0.016	0.039
theta	0	8°	0	8°

NOTES

1. Do not include mold flash or protrusion.
2. This drawing is subject to change without notice.

MSOP8

Package Outline Dimensions

VS1(MSOP-8-A)

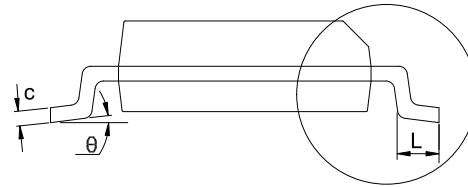
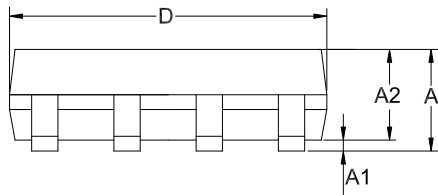
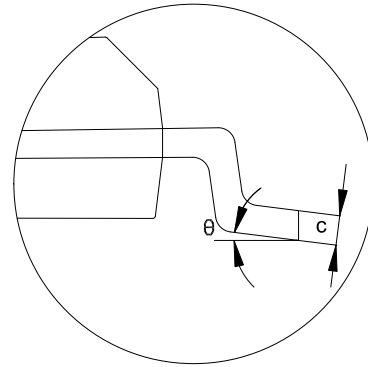
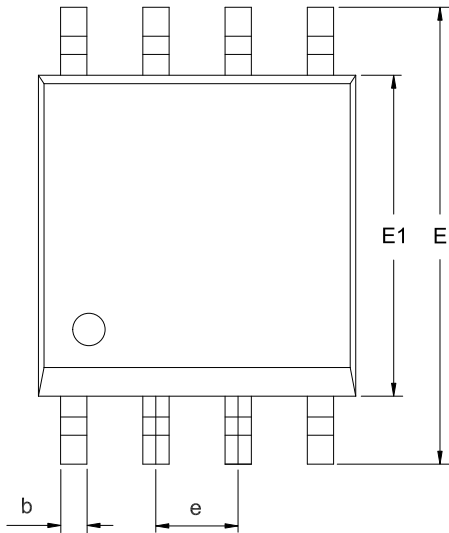

Symbol	Dimensions In Millimeters		Dimensions In Inches	
	MIN	MAX	MIN	MAX
A	0.800	1.100	0.031	0.043
A1	0.050	0.150	0.002	0.006
A2	0.750	0.950	0.030	0.037
b	0.250	0.380	0.010	0.015
c	0.090	0.230	0.004	0.009
D	2.900	3.100	0.114	0.122
E	4.700	5.100	0.185	0.201
E1	2.900	3.100	0.114	0.122
e	0.650 BSC		0.026 BSC	
L	0.400	0.800	0.016	0.031
θ	0	8°	0	8°

NOTES

1. Do not include mold flash or protrusion.
2. This drawing is subject to change without notice.

DFN3X3-8

Package Outline Dimensions

DF7(DFN3X3-8-D)

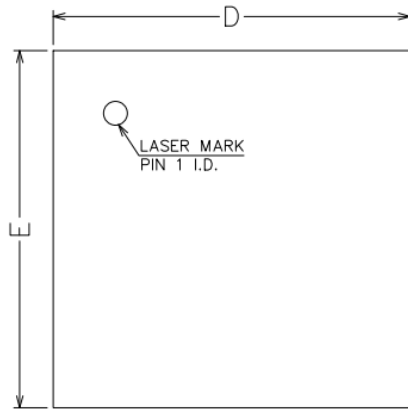

TOP VIEW

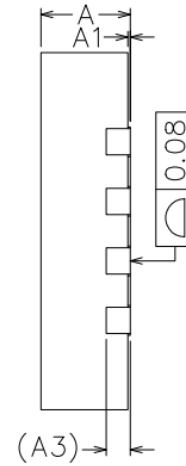

SIDE VIEW



SIDE VIEW

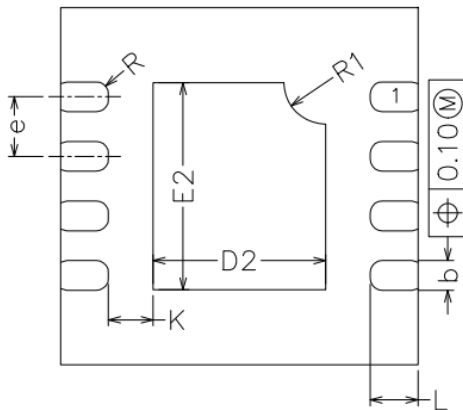

BOTTOM VIEW

NOTES

1. Do not include mold flash or protrusion.
2. This drawing is subject to change without notice.

Symbol	Dimensions In Millimeters		Dimensions In Inches	
	MIN	MAX	MIN	MAX
A	0.700	0.800	0.028	0.031
A1	0.000	0.050	0.000	0.002
b	0.200	0.300	0.008	0.012
A3	0.150	0.250	0.006	0.010
D	2.900	3.100	0.114	0.122
D2	1.350	1.550	0.053	0.061
E	2.900	3.100	0.114	0.122
E2	1.640	1.840	0.065	0.072
e	0.500 BSC		0.020 BSC	
L	0.300	0.500	0.012	0.020

IMPORTANT NOTICE AND DISCLAIMER

Copyright© 3PEAK 2012-2023. All rights reserved.

Trademarks. Any of the 思瑞浦 or 3PEAK trade names, trademarks, graphic marks, and domain names contained in this document /material are the property of 3PEAK. You may NOT reproduce, modify, publish, transmit or distribute any Trademark without the prior written consent of 3PEAK.

Performance Information. Performance tests or performance range contained in this document/material are either results of design simulation or actual tests conducted under designated testing environment. Any variation in testing environment or simulation environment, including but not limited to testing method, testing process or testing temperature, may affect actual performance of the product.

Disclaimer. 3PEAK provides technical and reliability data (including data sheets), design resources (including reference designs), application or other design recommendations, networking tools, security information and other resources "As Is". 3PEAK makes no warranty as to the absence of defects, and makes no warranties of any kind, express or implied, including without limitation, implied warranties as to merchantability, fitness for a particular purpose or non-infringement of any third-party's intellectual property rights. Unless otherwise specified in writing, products supplied by 3PEAK are not designed to be used in any life-threatening scenarios, including critical medical applications, automotive safety-critical systems, aviation, aerospace, or any situations where failure could result in bodily harm, loss of life, or significant property damage. 3PEAK disclaims all liability for any such unauthorized use.

X-ON Electronics

Largest Supplier of Electrical and Electronic Components

Click to view similar products for [Instrumentation Amplifiers](#) category:

Click to view products by [3PEAK](#) manufacturer:

Other Similar products are found below :

[ISL28274FAZ](#) [INA350ABSIDSGR](#) [HT8620ARZ](#) [TPA1286-SO1R](#) [AD624AD/+](#) [SGM620XS8G/TR](#) [INA351AIDSGR](#) [ADA4530-1ARZ-RL](#)
[AD8421ARMZ-RL](#) [TPA1286-VS1R](#) [MCP6N16-100EMF](#) [JM38510/13501BGA](#) [MCP6N16-001E/MF](#) [AD8422BRMZ-R7](#) [AD8426BCPZ-R7](#)
[INA188IDRJR](#) [AD8220BRMZ-R7](#) [LTC1100CN8#PBF](#) [INA333AIDGKRG4](#) [INA826SIDRCT](#) [INA826SIDRCR](#) [AD8221ARMZ](#)
[AD8226ARZ-RL](#) [AD694JN](#) [AD8420ARMZ-RL](#) [AD620ANZ](#) [AD621BR](#) [AD622ANZ](#) [AD623ANZ](#) [AD623BNZ](#) [AD625BDZ](#) [AD694ARZ-](#)
[REEL](#) [AD694JNZ](#) [AD620SQ/883B](#) [AD8220WARMZ](#) [AD8221ARMZ-R7](#) [AD8224ACPZ-R7](#) [AD8222ACPZ-RL](#) [AD8222HACPZ-R7](#)
[AD8226ARMZ](#) [AD8226ARMZ-R7](#) [AD8236ARMZ-R7](#) [AD8237ARMZ](#) [AD8237ARMZ-R7](#) [AD8250ARMZ](#) [AD8250ARMZ-R7](#)
[AD8253ARMZ](#) [AD8293G80ARJZ-R7](#) [AD8420ARMZ-R7](#) [AD8421ARMZ](#)