

### Features

- Supply Voltage: 4.5 V to 40 V or  $\pm 2.25$  V to  $\pm 20$  V
- Offset Voltage:  $\pm 15$   $\mu$ V Maximum
- Differential Input Voltage Range to Supply Rail, can Work as Comparator
- Input Rail to  $-V_s$ , Rail to Rail Output
- Bandwidth: 12 MHz
- Slew Rate: 12 V/ $\mu$ s
- Over-Temperature Protection
- Low Noise: 6 nV/ $\sqrt{\text{Hz}}$  at 1 kHz
- 2 kV HBM, 1 kV CDM
- $-40^\circ\text{C}$  to  $125^\circ\text{C}$  Operation Temperature Range

### Applications

- Instrumentation
- Active Filters, ASIC Input or Output Amplifier
- Sensor Interface
- Motor Control
- Industrial Control
- Low noise power supply

### Description

The TPA188X series amplifiers are the newest high supply voltage amplifiers with 15  $\mu$ V low offset, low noise, and stable high-frequency response. They incorporate 3PEAK's proprietary and patented design techniques to achieve excellent AC performance with 12 MHz bandwidth, 12 V/ $\mu$ s slew rate, and low distortion while drawing only 2000  $\mu$ A of quiescent current per amplifier. The input common-mode voltage range extends to  $V_-$ , and the outputs swing rail-to-rail.

The TPA188X has an over-temperature protection feature to guarantee chip safety. The output of TPA188X will enter high impedance when the die temperature reaches around  $170^\circ\text{C}$  and will recover the function when the die temperature is down to around  $150^\circ\text{C}$ . The product has a very small power temperature coefficient, which is helpful for temperature-sensitive applications.

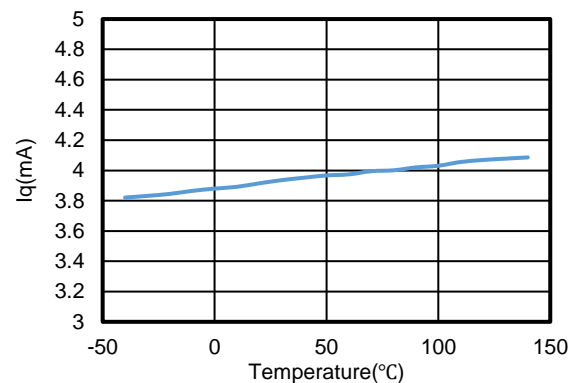

### Typical Application Circuit

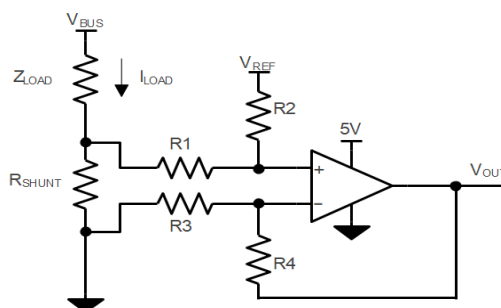

$$V_{OUT} = (I_{LOAD} \times R_{SHUNT}) \times (R_2 / R_1) + V_{REF}$$

$$\text{When } R_3 = R_1, R_2 = R_4, R_{SHUNT} \ll R_1$$

## Table of Contents

<b>Features</b> .....	1
<b>Applications</b> .....	1
<b>Description</b> .....	1
<b>Typical Application Circuit</b> .....	1
<b>Revision History</b> .....	3
<b>Pin Configuration and Functions</b> .....	4
<b>Specifications</b> .....	6
Absolute Maximum Ratings.....	6
ESD, Electrostatic Discharge Protection .....	6
Recommended Operating Conditions .....	6
Thermal Information .....	7
Electrical Characteristics .....	8
Electrical Characteristics (Continued) .....	9
Electrical Characteristics (Continued) .....	10
Typical Performance Characteristics.....	11
<b>Detailed Description</b> .....	14
Overview.....	14
Functional Block Diagram .....	14
<b>Application and Implementation</b> .....	15
Low Side Current Sensing Application .....	15
Power Supply Recommendations .....	15
<b>Tape and Reel Information</b> .....	16
<b>Package Outline Dimensions</b> .....	17
SOT23-5.....	17
SOIC8.....	18
MSOP8 .....	19
<b>Order Information</b> .....	20

## Revision History

Date	Revision	Notes
2019/1/10	Rev.Pre	Pre-Release Version
2020/5/19	Rev.A	Initial Version
2020/8/3	Rev.A.1	Added Test Figure
2020/11/6	Rev.A.2	Updated Test Figure: Iq vs. temperature, Vout vs. Iout
2021/7/7	Rev.A.3	Updated maximum rating: Input voltage: $(-V_s) - 0.3$ to $(+V_s) + 0.3$ -> $(-V_s) - 0.3$ to 40 V Differential Input Voltage : $(+V_s) - (-V_s)$ -> $(-V_s) - (+V_s)$ to $(+V_s) - (-V_s)$
2022/8/18	Rev.A.4	Updated to new document format including package dimensions. Updated the working voltage to 40V, the absolute rating voltage to 42V
2023/6/1	Rev.A.5	Updated address of web site. Updated the working voltage description, added dual-supply description.

## Pin Configuration and Functions

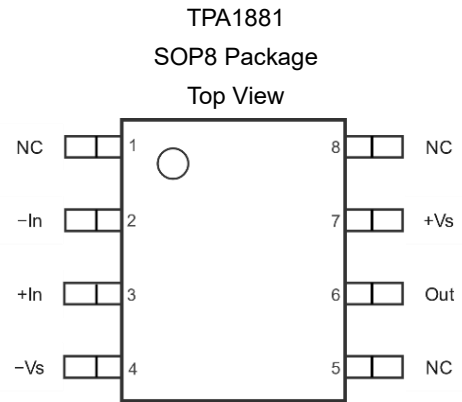
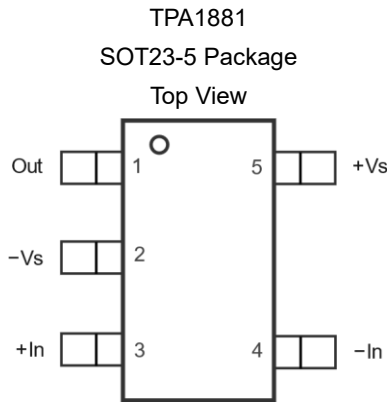

**Table 1. Pin Functions: TPA1881**

Pin		Name	I/O	Description
SOT23-5	SOP8			
1	6	Out	Output	Output
2	4	-Vs		Negative power supply
3	3	+In	Input	Noninverting input
4	2	-In	Input	Inverting input
5	7	+Vs		Positive power supply
	1	NC		Not connected
	5	NC		Not connected
	8	NC		Not connected

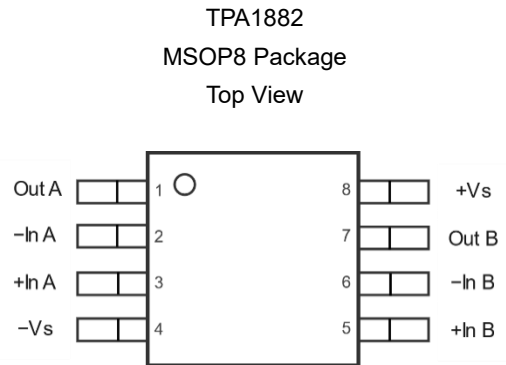
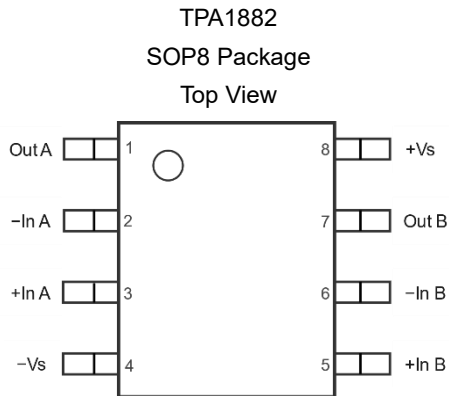

**Table 2. Pin Functions: TPA1882**

Pin	Name	I/O	Description
1	Out A	Output	Output
2	-In A	Input	Inverting input
3	+In A	Input	Noninverting input
4	-Vs		Negative power supply
5	+In B	Input	Noninverting input
6	-In B	Input	Inverting input
7	Out B	Output	Output
8	+Vs		Positive power supply

## Specifications

### Absolute Maximum Ratings

Over operating ambient temperature (unless otherwise noted) <sup>(1)</sup>

Parameter	Min	Max	Unit
Supply Voltage, (+V <sub>S</sub> ) – (–V <sub>S</sub> )		42 V	V
Input Voltage	(–V <sub>S</sub> ) – 0.3	42 V	V
Differential Input Voltage	(–V <sub>S</sub> ) – (+V <sub>S</sub> )	(+V <sub>S</sub> ) – (–V <sub>S</sub> )	V
Input Current: +I <sub>N</sub> , –I <sub>N</sub> <sup>(2)</sup>	–10	10	mA
Output Voltage	(–V <sub>S</sub> ) – 0.3	(+V <sub>S</sub> ) + 0.3	V
Output Short-Circuit Duration <sup>(3)</sup>		Infinite	
Maximum Operating Junction Temperature		150	°C
Operating Temperature Range	–40	125	°C
Storage Temperature Range	–65	150	°C
Lead Temperature (Soldering, 10 sec)		260	°C

(1) Stresses beyond those listed under Absolute Maximum Ratings may cause permanent damage to the device. Exposure to any Absolute Maximum Rating condition for extended periods may affect device reliability and lifetime.

(2) The inputs are protected by ESD protection diodes to the negative power supply. If the input extends more than 300 mV beyond the negative power supply, the input current should be limited to less than 10 mA.

(3) A heat sink may be required to keep the junction temperature below the absolute maximum. This depends on the power supply voltage and how many amplifiers are shorted. Thermal resistance varies with the amount of PC board metal connected to the package. The specified values are for short traces connected to the leads.

### ESD, Electrostatic Discharge Protection

Symbol	Parameter	Condition	Minimum Level	Unit
HBM <sup>(1)</sup>	Human Body Model ESD	ANSI/ESDA/JEDEC JS-001	2	kV
CDM <sup>(2)</sup>	Charged Device Model ESD	ANSI/ESDA/JEDEC JS-002	1	kV
LU	Latch Up	JESD 78, 25°C	500	mA
		JESD 78, 125°C	200	mA

(1) JEDEC document JEP155 states that 500-V HBM allows safe manufacturing with a standard ESD control process.

(2) JEDEC document JEP157 states that 250-V CDM allows safe manufacturing with a standard ESD control process.

### Recommended Operating Conditions

Parameter	Min	Typ	Max	Unit
V <sub>S</sub>	Supply Voltage, (+V <sub>S</sub> ) – (–V <sub>S</sub> )	4.5(±2.25)	40(±20)	V
T <sub>A</sub>	Operating Temperature Range	–40	125	°C

**Thermal Information**

Package Type	$\theta_{JA}$	$\theta_{JC}$	Unit
SOT23-5	250	81	°C/W
SOP8	158	43	°C/W
MSOP8	210	45	°C/W

## Electrical Characteristics

All test condition is  $V_S = 30\text{ V}$ ,  $T_A = 25^\circ\text{C}$ ,  $R_L = 10\text{ k}\Omega$ , unless otherwise noted.

Symbol	Parameter	Conditions	$T_A$	Min	Typ	Max	Unit
<b>Power Supply</b>							
$V_S$	Supply Voltage Range			4.5		40	V
$I_Q$	Quiescent Current per Amplifier	$V_S = 40\text{ V}$			2.4	3	mA
PSRR	Power Supply Rejection Ratio	$V_S = 30\text{ V}$			2	2.5	mA
		$V_S = 30\text{ V}$	$-40^\circ\text{C to }125^\circ\text{C}$			2.7	mA
		$V_S = 5\text{ V}$			1.9	2.4	mA
		$V_S = 5\text{ V}$	$-40^\circ\text{C to }125^\circ\text{C}$			2.6	mA
		$V_S = 4.5\text{ V to }36\text{ V}$		135	155		dB
PSRR	Power Supply Rejection Ratio	$V_S = 4.5\text{ V to }36\text{ V}$	$-40^\circ\text{C to }125^\circ\text{C}$	130			dB
$V_S$	Supply Voltage Range			4.5		36	V
<b>Input Characteristics</b>							
$V_{OS}$	Input Offset Voltage	$V_S = 40\text{ V}, V_{CM} = 20\text{ V}$		-15		15	$\mu\text{V}$
		$V_S = 30\text{ V}, V_{CM} = 15\text{ V}$		-15		15	$\mu\text{V}$
			$-40^\circ\text{C to }125^\circ\text{C}$	-25		25	$\mu\text{V}$
		$V_S = 5\text{ V}, V_{CM} = 2.5\text{ V}$		-15		15	$\mu\text{V}$
			$-40^\circ\text{C to }125^\circ\text{C}$	-25		25	$\mu\text{V}$
$V_{OS\text{ TC}}$	Input Offset Voltage Drift		$-40^\circ\text{C to }125^\circ\text{C}$		0.05	0.15	$\mu\text{V}/^\circ\text{C}$
$I_B$	Input Bias Current				10		pA
			$-40^\circ\text{C to }125^\circ\text{C}$		100		pA
$I_{OS}$	Input Offset Current				100		pA
$I_{IN}$	Different Input Current	$V_S = 36\text{ V}, V_{ID} = 36\text{ V}$				100	$\mu\text{A}$
			$-40^\circ\text{C to }125^\circ\text{C}$			120	$\mu\text{A}$
$C_{IN}$	Input Capacitance	Differential Mode			5		pF
		Common Mode			2.5		pF
$A_V$	Open-loop Voltage Gain	$R_{LOAD} = 10\text{ k}\Omega, V_{OUT} = 0.5\text{ V to }29.5\text{ V}$		135	155		dB
			$-40^\circ\text{C to }125^\circ\text{C}$	130			dB
$V_{CMR}$	Common-mode Input Voltage Range			(V-)		(V+) – 1.5	V
CMRR	Common Mode Rejection Ratio	$V_{CM} = 0\text{ V to }28.5\text{ V}$		135	155		dB
			$-40^\circ\text{C to }125^\circ\text{C}$	130			dB



**Electrical Characteristics (Continued)**

 All test condition is  $V_S = 30\text{ V}$ ,  $T_A = 25^\circ\text{C}$ ,  $R_L = 10\text{ k}\Omega$ , unless otherwise noted.

Symbol	Parameter	Conditions	$T_A$	Min	Typ	Max	Unit
<b>Output Characteristics</b>							
	Output Swing from Positive Rail	$R_{LOAD} = 100\text{ k}\Omega$ to $V_S/2$			12	25	mV
			-40°C to 85°C			35	mV
			-40°C to 125°C			40	mV
		$R_{LOAD} = 10\text{ k}\Omega$ to $V_S/2$			80	120	mV
			-40°C to 85°C			170	mV
			-40°C to 125°C			200	mV
		$R_{LOAD} = 2\text{ k}\Omega$ to $V_S/2$			370	500	mV
			-40°C to 85°C			700	mV
			-40°C to 125°C			750	mV
	Output Swing from Negative Rail	$R_{LOAD} = 100\text{ k}\Omega$ to $V_S/2$			5	25	mV
			-40°C to 85°C			30	mV
			-40°C to 125°C			30	mV
		$R_{LOAD} = 10\text{ k}\Omega$ to $V_S/2$			30	80	mV
			-40°C to 85°C			95	mV
			-40°C to 125°C			105	mV
		$R_{LOAD} = 2\text{ k}\Omega$ to $V_S/2$			140	300	mV
			-40°C to 85°C			450	mV
			-40°C to 125°C			500	mV
$I_{sc}$	Output Short-Circuit Current	Source		70	95		mA
			-40°C to 85°C	55			mA
			-40°C to 125°C	50			mA
		Sink		130	150		mA
			-40°C to 85°C	100			mA
			-40°C to 125°C	85			mA

**Electrical Characteristics (Continued)**

All test condition is  $V_S = 30\text{ V}$ ,  $T_A = 25^\circ\text{C}$ ,  $R_L = 10\text{ k}\Omega$ , unless otherwise noted.

Symbol	Parameter	Conditions	$T_A$	Min	Typ	Max	Unit
<b>AC Specifications</b>							
GBW	Gain-Bandwidth Product				12		MHz
SR	Slew Rate	$G = 1$ , 10 V step		8	12		V/ $\mu\text{s}$
			$-40^\circ\text{C}$ to $125^\circ\text{C}$	7			V/ $\mu\text{s}$
$t_{OR}$	Overload Recovery				500		ns
$t_S$	Settling Time, 0.1%	$G = 1$ , 10 V step			5		$\mu\text{s}$
	Settling Time, 0.01%				7		$\mu\text{s}$
PM	Phase Margin	$R_L=10\text{ K}$ , $C_L= 50\text{ pF}$			60		$^\circ$
GM	Gain Margin	$R_L=10\text{ K}$ , $C_L= 50\text{ pF}$			10		dB
<b>Noise Performance</b>							
$E_N$	Input Voltage Noise	$f = 0.1\text{ Hz}$ to $10\text{ Hz}$			0.1		$\mu\text{V}_{PP}$
$e_N$	Input Voltage Noise Density	$f = 0.1\text{ kHz}$			6		nV/ $\sqrt{\text{Hz}}$
		$f = 1\text{ kHz}$			6		nV/ $\sqrt{\text{Hz}}$
		$f = 10\text{ kHz}$			7		nV/ $\sqrt{\text{Hz}}$
$i_N$	Input Current Noise	$f = 10\text{ kHz}$			200		fA/ $\sqrt{\text{Hz}}$
THD+N	Total Harmonic Distortion and Noise	$f = 1\text{ kHz}$ , $G = 1$ , $R_L = 10\text{ k}\Omega$ , $V_{OUT} = 6\text{ V}_{RMS}$			0.0002		%

**Typical Performance Characteristics**

Test condition:  $V_S = \pm 15\text{ V}$ ,  $V_{CM} = 0\text{ V}$ ,  $R_L = 10\text{ k}\Omega$ , unless otherwise specified.

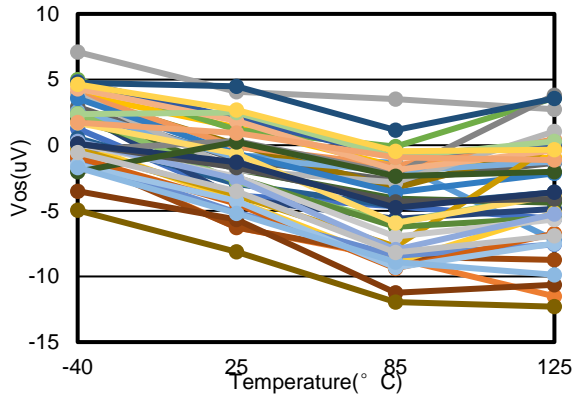

**Figure 1. Vos at 30 V Vs, 15 V V<sub>CM</sub> vs. Temperature, 40pcs**

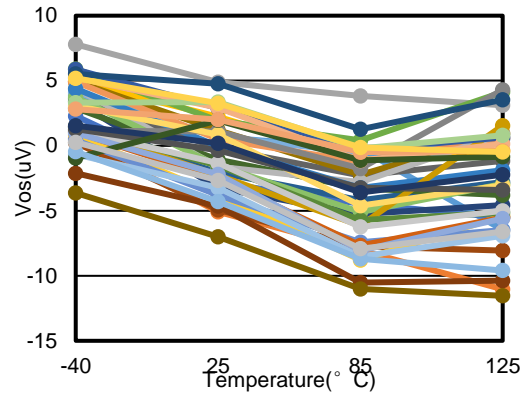

**Figure 2. Vos at 5 V Vs, 2.5 V V<sub>CM</sub> vs. Temperature, 40pcs**

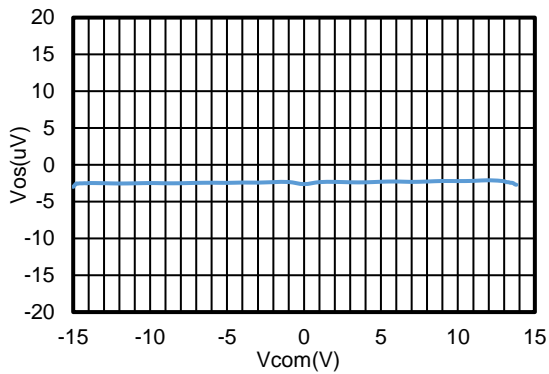

**Figure 3. Offset Voltage vs. Common-Mode Voltage**

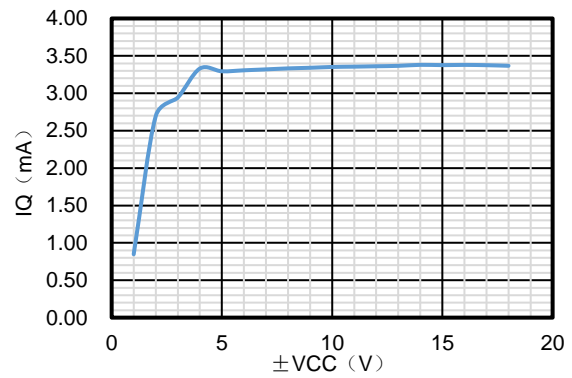

**Figure 4. Iq vs. Supply Voltage**

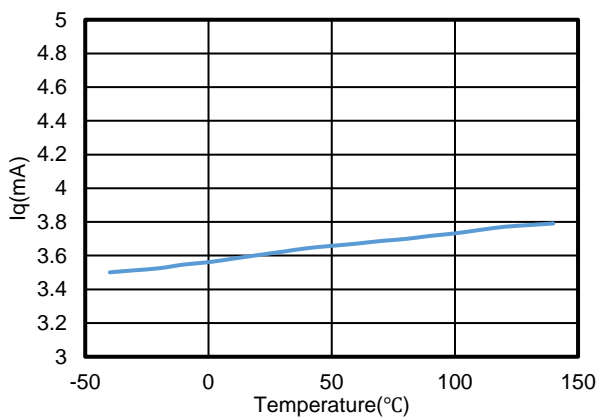

**Figure 5. Iq vs. Temperature, +-2.5 V Supply, TPA1882**

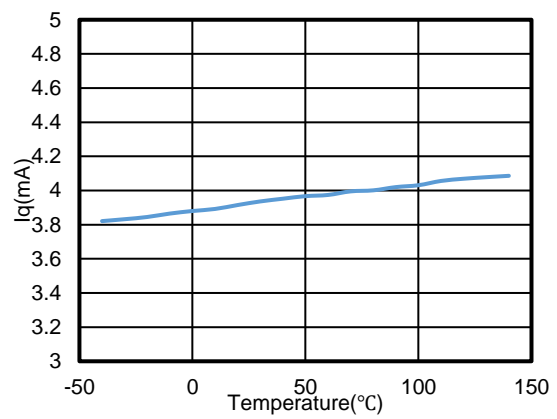

**Figure 6. Iq vs. Temperature, +-15 V Supply, TPA1882**

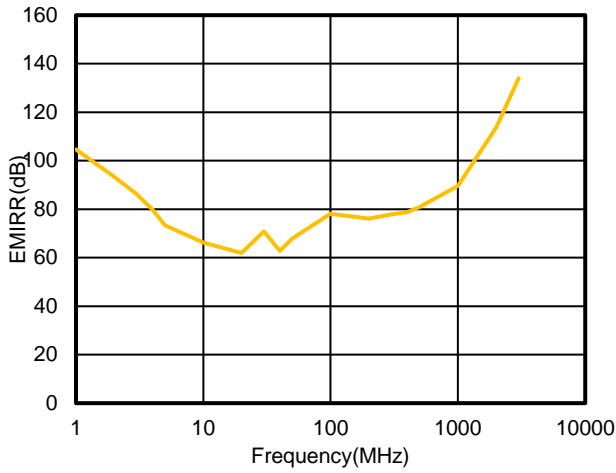

Figure 7. EMIRR vs. Frequency

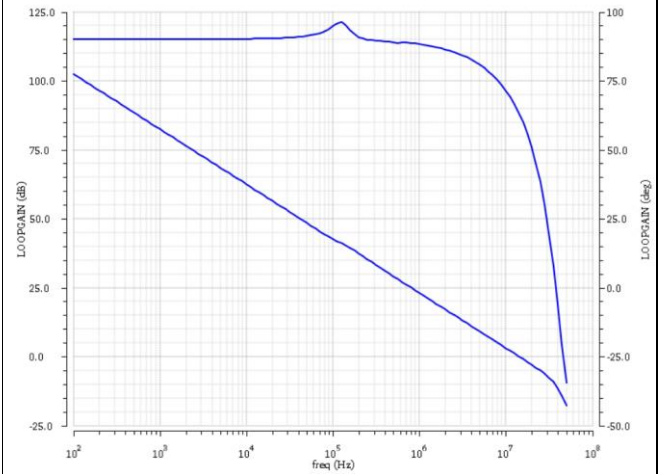

Figure 8. Open Loop Gain and Phase vs. Frequency

$R_L = 10\text{ k}\Omega$ ,  $C_L = 50\text{ pF}$

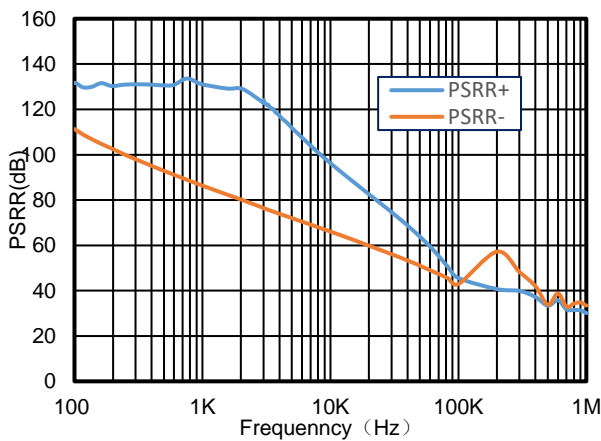

Figure 9. PSRR vs. Frequency

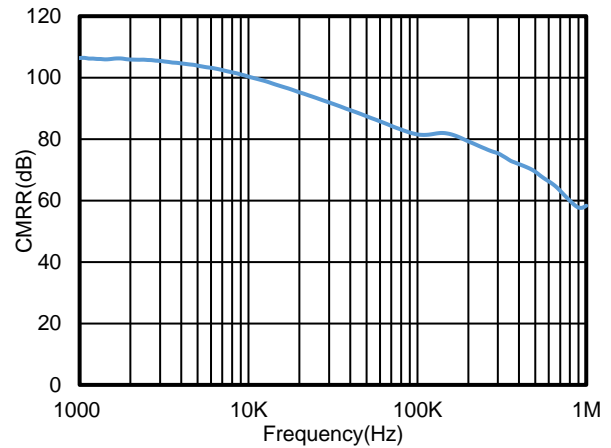
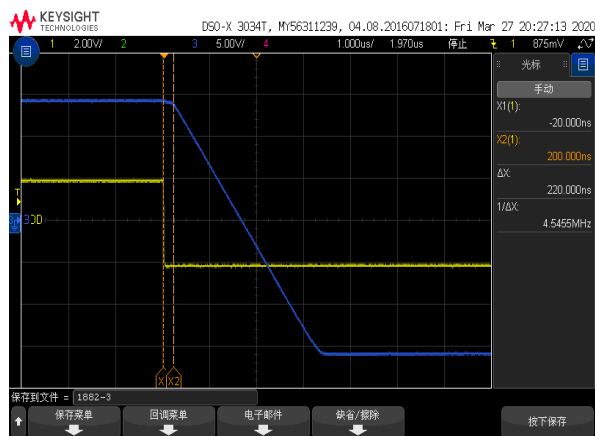
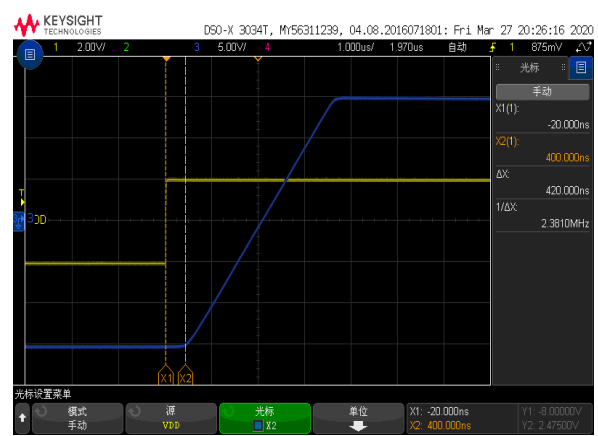

Figure 10. Negative Overload Recovery



Time: 2 us/div, Measure Time: 220 ns  
 $R_L=2\text{ K}$ ,  $C_L=100\text{ pF}$ ,  $G=10$

Figure 11. Positive Overload Recovery



Time: 2 us/div, Measure Time: 420 ns  
 $R_L=2\text{ K}$ ,  $C_L=100\text{ pF}$ ,  $G=10$

Figure 12. Negative Overload Recovery

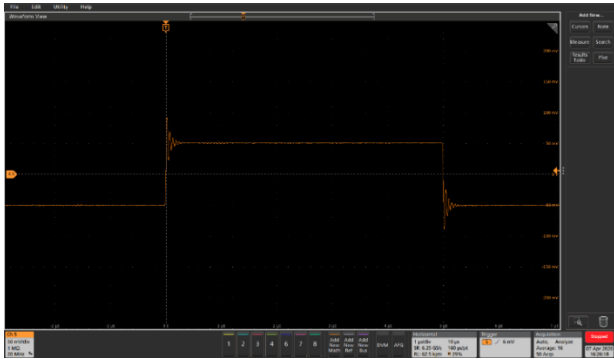

Voltage: 50 mV/div, Time: 2 us/div  
 $R_L=2\text{ K}$ ,  $C_L=100\text{ pF}$ ,  $G=1$

**Figure 13. 100 mV Signal Step Response**

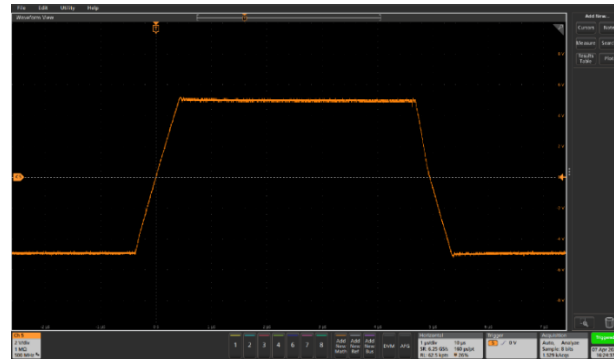

Voltage: 2 V/div, Time: 2  $\mu$ s/div  
 $R_L=2\text{ K}$ ,  $C_L=100\text{ pF}$ ,  $G=1$

**Figure 14. 10 V Signal Step Response**

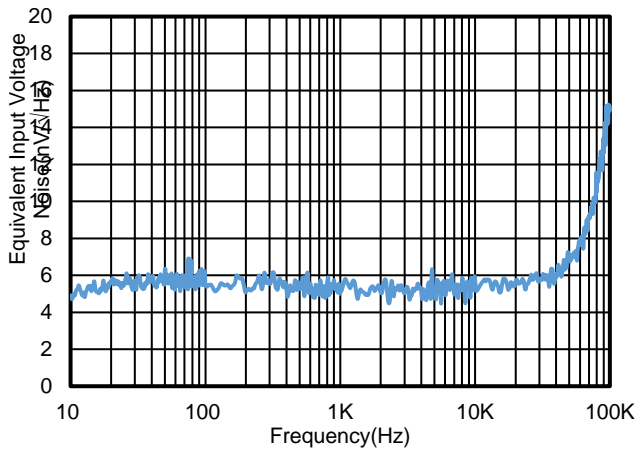

**Figure 15. Voltage Noise Spectral Density vs. Frequency**

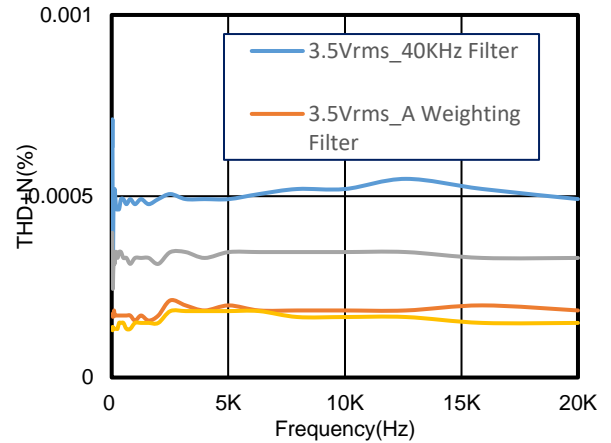

**Figure 16.  $V_{OUT}$  vs.  $I_{OUT}$ , Sink**

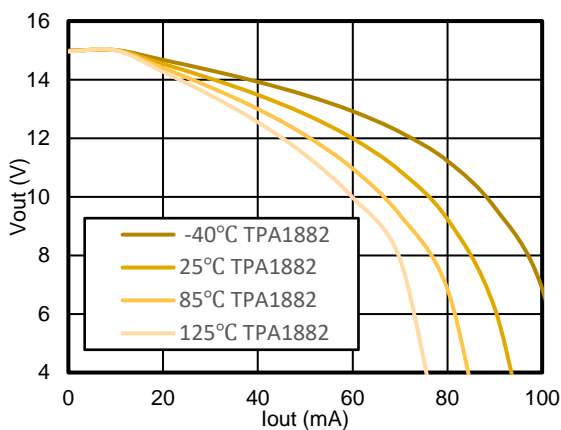

**Figure 17.  $V_{OUT}$  vs.  $I_{OUT}$ , Source**

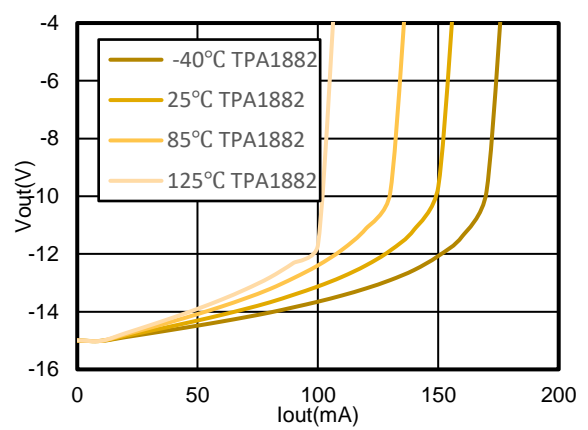

**Figure 18.  $V_{OUT}$  vs.  $I_{OUT}$ , Sink**

## Detailed Description

### Overview

The TPA188x series op amps can operate on a single-supply voltage (4.5 V to 40 V), or a split-supply voltage ( $\pm 2.25$  V to  $\pm 20$  V), making them highly versatile and easy to use. The power-supply pins should have local bypass ceramic capacitors (typically 0.01  $\mu$ F to 0.1  $\mu$ F). Parameters that can exhibit variance with regard to operating voltage or temperature are presented in the Typical Characteristics.

### Functional Block Diagram

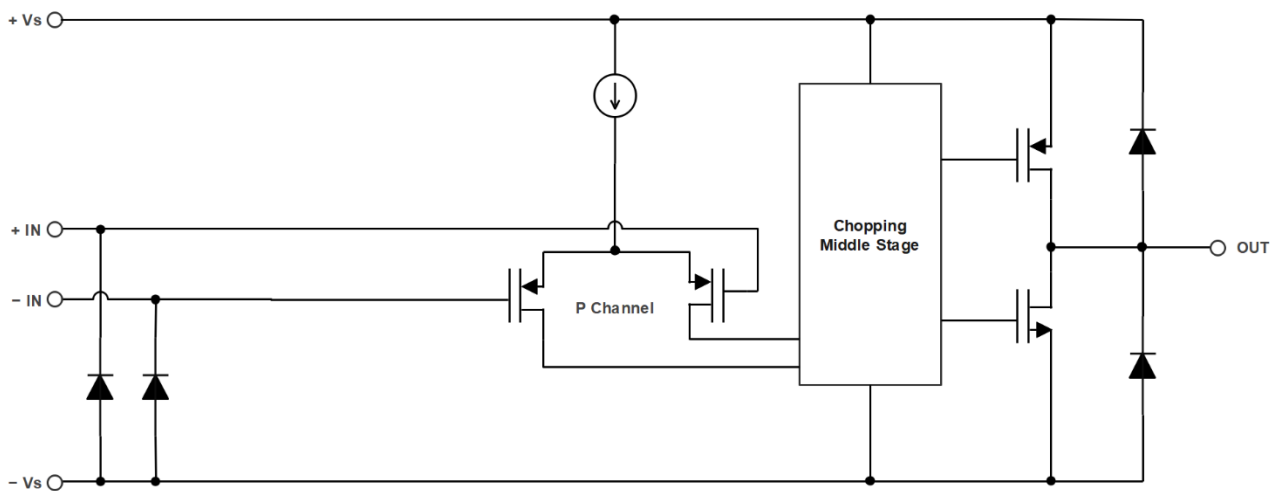

Figure 19. Functional Block Diagram

## Application and Implementation

### NOTE

Information in the following application sections is not part of the 3PEAK's component specification and 3PEAK does not warrant its accuracy or completeness. 3PEAK's customers are responsible for determining suitability of components for their purposes. Customers should validate and test their design implementation to confirm system functionality.

### Low Side Current Sensing Application

Figure 20 shows the TPA188X configured in a low-side current sensing application. The low-side current sensing method consists of placing a sense resistor between the load and the circuit ground. The voltage dropping across the resistor is amplified by different amplifier circuits with TPA188X. The  $V_{REF}$  can be used to add bias voltage to output voltage. Particular attention must be paid to the matching and precision of R1, R2, R3, and R4, to maximize the accuracy of the measurement.

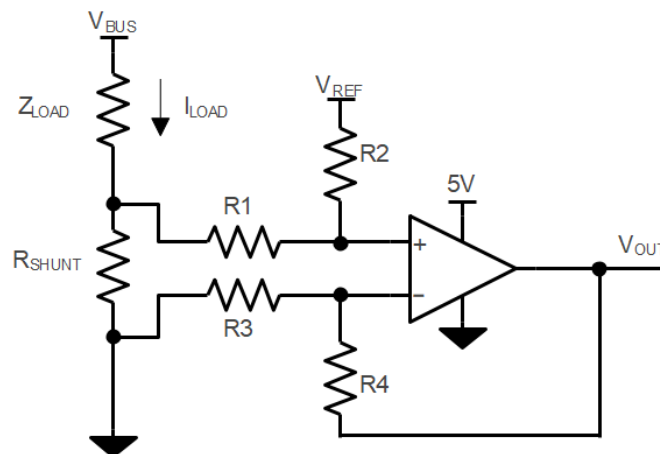

$$V_{OUT} = (I_{LOAD} \times R_{SHUNT}) \times (R2 / R1) + V_{REF}$$

$$\text{When } R3 = R1, R2 = R4, R_{SHUNT} \ll R1$$

**Figure 20. Dual Supply Operation Connections**

### Power Supply Recommendations

Place 0.1- $\mu$ F bypass capacitors close to the power supply pins for reducing coupling errors from the noisy or high impedance power supplies.

### Tape and Reel Information

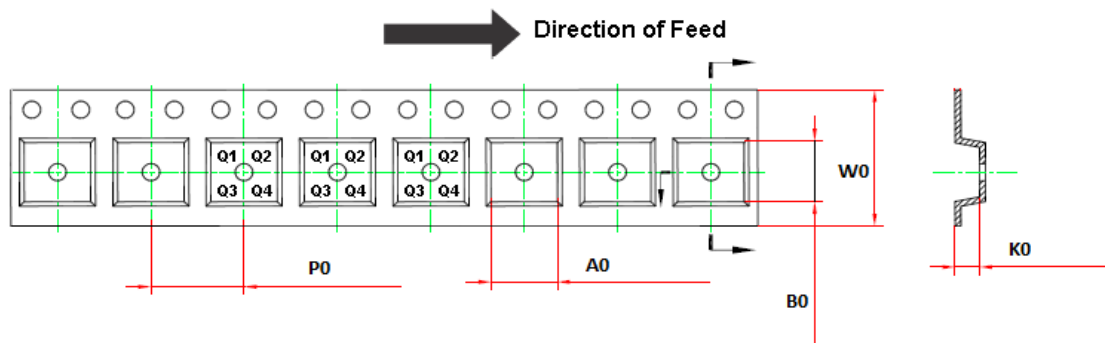
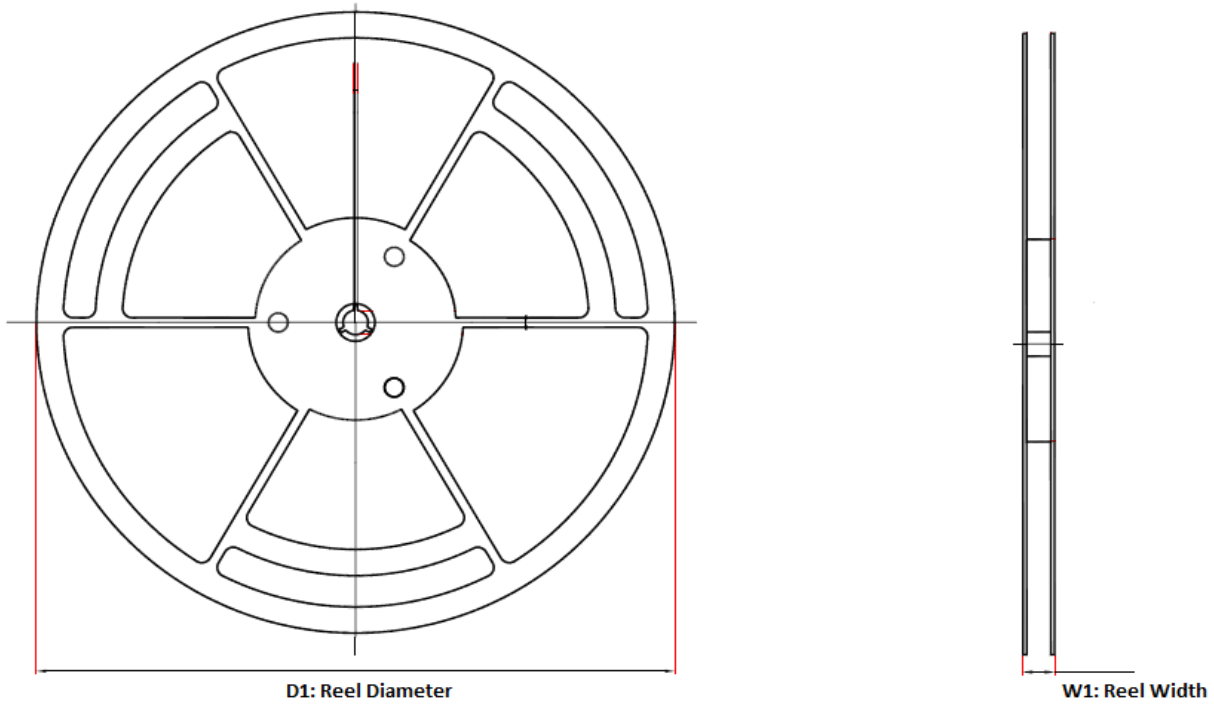

Order Number	Package	D1 (mm)	W1 (mm)	A0 (mm)	B0 (mm)	K0 (mm)	P0 (mm)	W0 (mm)	Pin1 Quadrant
TPA1881-TR	SOT23-5	180.0	13.1	3.2	3.2	1.4	4.0	8.0	Q3
TPA1881-SR	SOP8	330.0	17.6	6.4	5.4	2.1	8.0	12.0	Q1
TPA1882-SR	SOP8	330.0	17.6	6.4	5.4	2.1	8.0	12.0	Q1
TPA1882-VR	MSOP8	330.0	17.6	5.2	3.3	1.5	8.0	12.0	Q1



### Package Outline Dimensions

SOT23-5

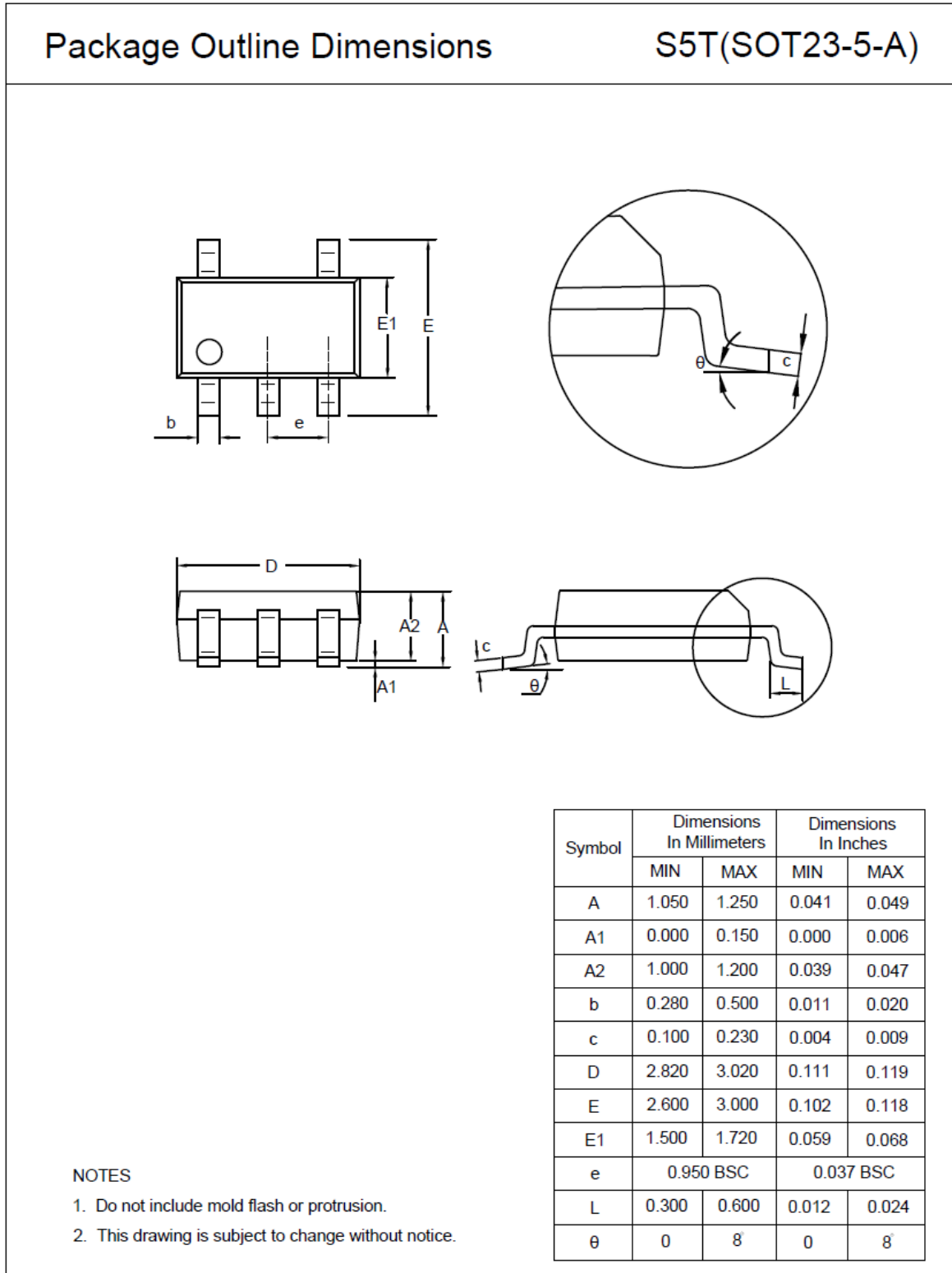

SOIC8

Package Outline Dimensions

SO1(SOP-8-A)

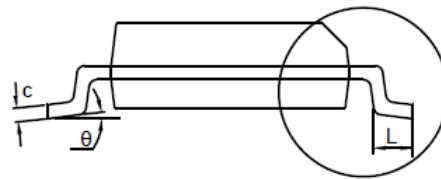
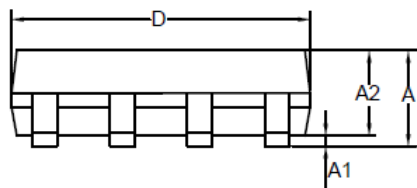
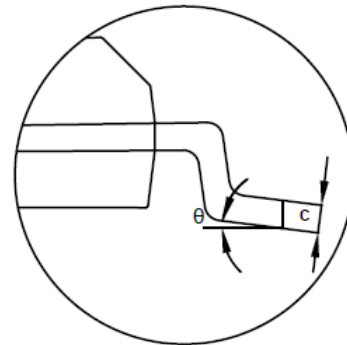
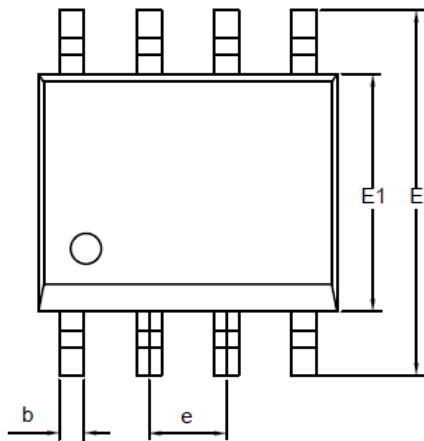

Symbol	Dimensions In Millimeters		Dimensions In Inches	
	MIN	MAX	MIN	MAX
A	1.350	1.750	0.053	0.069
A1	0.050	0.250	0.002	0.010
A2	1.250	1.550	0.049	0.061
b	0.330	0.510	0.013	0.020
c	0.170	0.250	0.007	0.010
D	4.700	5.100	0.185	0.201
E	5.800	6.200	0.228	0.244
E1	3.800	4.000	0.150	0.157
e	1.270 BSC		0.050 BSC	
L	0.400	1.000	0.016	0.039
$\theta$	0	8	0	8

NOTES

1. Do not include mold flash or protrusion.
2. This drawing is subject to change without notice.

MSOP8

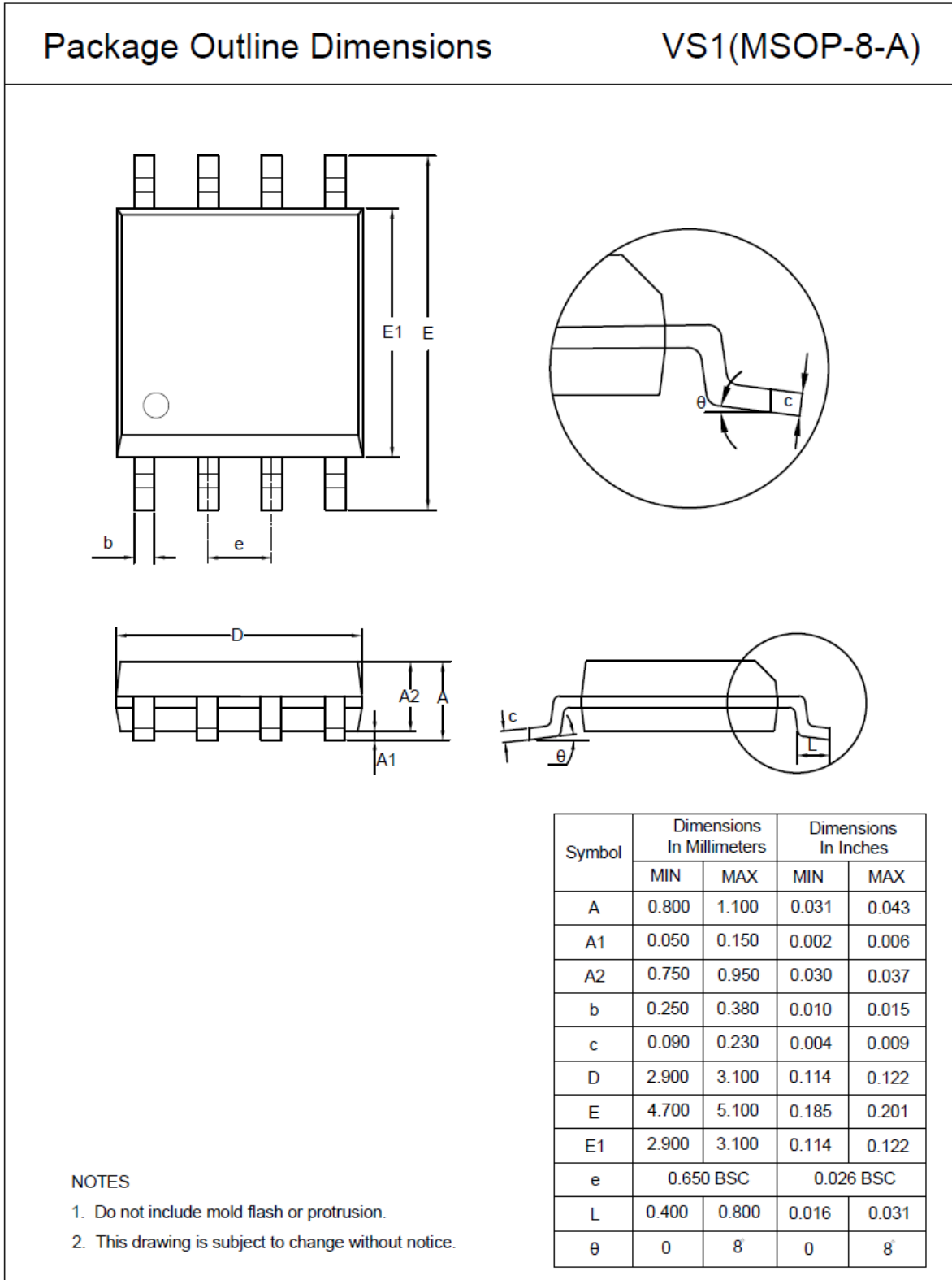

## Order Information

Order Number	Operating Temperature Range	Package	Marking Information	MSL	Transport Media, Quantity	Eco Plan
TPA1881-SR	-40 to 125°C	SOP8	1881	3	Tape and Reel, 4000	TPA1881-SR
TPA1881-TR	-40 to 125°C	SOT23-5	A88	3	Tape and Reel, 3000	TPA1881-TR
TPA1882-SR	-40 to 125°C	SOP8	1882	3	Tape and Reel, 4000	TPA1882-SR
TPA1882-VR	-40 to 125°C	MSOP8	1882	3	Tape and Reel, 3000	TPA1882-VR

**Green:** 3PEAK defines "Green" to mean RoHS compatible and free of halogen substances.

---

 **3PEAK and the 3PEAK logo are registered trademarks of 3PEAK INCORPORATED. All other trademarks are the property of their respective owners.**

---

## X-ON Electronics

Largest Supplier of Electrical and Electronic Components

*Click to view similar products for [Operational Amplifiers - Op Amps](#) category:*

*Click to view products by [3PEAK](#) manufacturer:*

Other Similar products are found below :

[430227FB](#) [UPC451G2-A](#) [UPC824G2-A](#) [LT1678IS8](#) [UPC258G2-A](#) [NCV33202DMR2G](#) [NJM324E](#) [NTE925](#) [AZV358MTR-G1](#)  
[AP4310AUMTR-AG1](#) [AZV358MMTR-G1](#) [SCY33178DR2G](#) [NCV5652MUTWG](#) [NCV20034DR2G](#) [NTE778S](#) [NTE871](#) [NTE937](#)  
[MCP6V16UT-E/OT](#) [SCY6358ADR2G](#) [UPC4570G2-E1-A](#) [NCS20282FCTTAG](#) [UPC834G2-E1-A](#) [UPC1458G2-E2-A](#) [UPC813G2-E2-A](#)  
[UPC458G2-E1-A](#) [UPC824G2-E2-A](#) [UPC4574G2-E2-A](#) [UPC4558G2-E2-A](#) [UPC4560G2-E1-A](#) [UPC4062G2-E1-A](#) [UPC258G2-E1-A](#)  
[UPC4742GR-9LG-E1-A](#) [UPC4742G2-E1-A](#) [UPC832G2-E2-A](#) [UPC842G2-E1-A](#) [UPC802G2-E1-A](#) [UPC4741G2-E2-A](#) [UPC4572G2-E2-A](#)  
[UPC844GR-9LG-E2-A](#) [UPC259G2-E1-A](#) [UPC4741G2-E1-A](#) [UPC4558G2-E1-A](#) [UPC4574GR-9LG-E1-A](#) [UPC1251GR-9LG-E1-A](#)  
[UPC4744G2-E1-A](#) [UPC4092G2-E1-A](#) [UPC4574G2-E1-A](#) [UPC4062G2-E2-A](#) [UPC451G2-E2-A](#) [UPC832G2-E1-A](#)