

Features

- Precision low voltage monitoring
- 200 ms (typical) reset timeout
- Open-drain Active-low output (TPV803)
- Push-pull Active-low output (TPV809)
- Push-pull Active-high output (TPV810)
- Low power consumption: 2.2 μ A
- Guaranteed reset output valid to $V_{CC} = 1$ V
- Power supply glitch immunity
- Specified from -40°C to $+125^{\circ}\text{C}$
- 3-lead SOT-23-3 and SOT-23 package

Applications

- Microprocessor systems
- Computers
- Controllers
- Intelligent instruments
- Portable equipment

Description

The TPV803/809/810 is a series of supervisory circuit that monitors power supply voltage levels and provides a power-on reset signal. They provide a reset output during power-up, power-down, and brownout conditions. The reset timeout periods are fixed at 200 ms (typical).

The TPV803 and TPV809 provide an active low reset signal ($\overline{\text{RESET}}$), whereas the TPV810 provides an active high signal (RESET) output. The TPV809 and TPV810 have push-pull outputs, whereas the TPV803 has an open-drain output, which requires an external pull-up resistor.

The TPV803/809/810 is available in 3-lead SOT-23-3 and SOT-23 package and typically consumes only 2.2 μ A, suitable for use in low power, portable applications.

Function block diagram

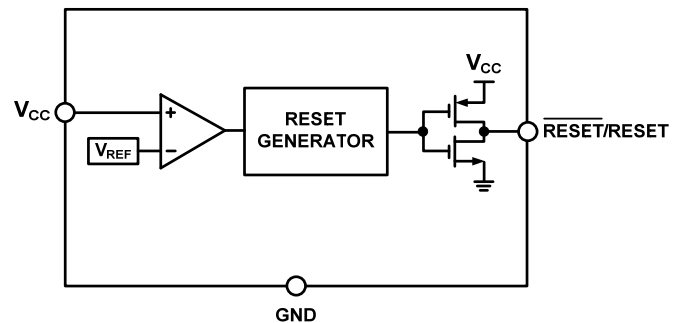

Figure 1.

Table of Contents

Features	1
Applications.....	1
Description.....	1
Function block diagram.....	1
Table of Contents	2
Revision History	3
Pin Configuration and Functions	4
Order Information.....	4
Absolute Maximum Ratings	7
ESD, Electrostatic Discharge Protection.....	7
Electrical Characteristics	8
Typical Performance Characteristics	9
Theory of Operation	11
Package Outline Dimensions.....	12

Revision History

Table 1.

Date	Revision	Notes
2018/9/1	Rev.1.0	Initial Version
2018/1/1	Rev.1.1	Update RESET VOH, VOL parameters.

Pin Configuration and Functions

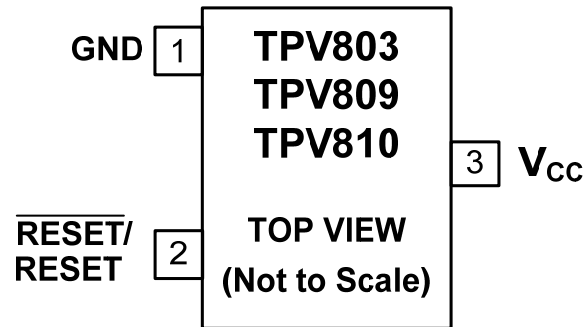

PIN NO	Name	Description
1	GND	Ground.
2	$\overline{\text{RESET}}$	TPV803: Open-drain Active Low Logic Output. RESET remains low while VCC is below the reset threshold and remains low for 200 ms (typical) after VCC rises above the reset threshold.
	$\overline{\text{RESET}}$	TPV809: Push-pull Active Low Logic Output. RESET remains low while VCC is below the reset threshold and remains low for 200 ms (typical) after VCC rises above the reset threshold.
	RESET	TPV810: Push-pull Active High Logic Output. RESET remains high while VCC is below the reset threshold and remains low for 200 ms (typical) after VCC rises above the reset threshold.
3	VCC	Power Supply Voltage Being Monitored.

Order Information

Table 2.

Model Name	Order Number	Package	Transport Media, Quantity	Package Marking
TPV803	TPV803V-3TR	SOT-23-3	Tape and Reel, 3,000	V8V
TPV803	TPV803W-3TR	SOT-23-3	Tape and Reel, 3,000	V8W
TPV803	TPV803Y-3TR	SOT-23-3	Tape and Reel, 3,000	V8Y
TPV803	TPV803Z-3TR	SOT-23-3	Tape and Reel, 3,000	V8Z
TPV803	TPV803R-3TR	SOT-23-3	Tape and Reel, 3,000	V8R
TPV803	TPV803S-3TR	SOT-23-3	Tape and Reel, 3,000	V8S
TPV803	TPV803T-3TR	SOT-23-3	Tape and Reel, 3,000	V8T
TPV803	TPV803M-3TR	SOT-23-3	Tape and Reel, 3,000	V8M
TPV803	TPV803L-3TR	SOT-23-3	Tape and Reel, 3,000	V8L
TPV803	TPV803V-3STR	SOT-23	Tape and Reel, 3,000	V8V
TPV803	TPV803W-3STR	SOT-23	Tape and Reel, 3,000	V8W
TPV803	TPV803Y-3STR	SOT-23	Tape and Reel, 3,000	V8Y
TPV803	TPV803Z-3STR	SOT-23	Tape and Reel, 3,000	V8Z

TPV803	TPV803R-3STR	SOT-23	Tape and Reel, 3,000	V8R
TPV803	TPV803S-3STR	SOT-23	Tape and Reel, 3,000	V8S
TPV803	TPV803T-3STR	SOT-23	Tape and Reel, 3,000	V8T
TPV803	TPV803M-3STR	SOT-23	Tape and Reel, 3,000	V8M
TPV803	TPV803L-3STR	SOT-23	Tape and Reel, 3,000	V8L

Model Name	Order Number	Package	Transport Media, Quantity	Package Marking
TPV809	TPV809V-3TR	SOT-23-3	Tape and Reel, 3,000	V2V
TPV809	TPV809W-3TR	SOT-23-3	Tape and Reel, 3,000	V2W
TPV809	TPV809Y-3TR	SOT-23-3	Tape and Reel, 3,000	V2Y
TPV809	TPV809Z-3TR	SOT-23-3	Tape and Reel, 3,000	V2Z
TPV809	TPV809R-3TR	SOT-23-3	Tape and Reel, 3,000	V2R
TPV809	TPV809S-3TR	SOT-23-3	Tape and Reel, 3,000	V2S
TPV809	TPV809T-3TR	SOT-23-3	Tape and Reel, 3,000	V2T
TPV809	TPV809M-3TR	SOT-23-3	Tape and Reel, 3,000	V2M
TPV809	TPV809L-3TR	SOT-23-3	Tape and Reel, 3,000	V2L
TPV809	TPV809V-3STR	SOT-23	Tape and Reel, 3,000	V2V
TPV809	TPV809W-3STR	SOT-23	Tape and Reel, 3,000	V2W
TPV809	TPV809Y-3STR	SOT-23	Tape and Reel, 3,000	V2Y
TPV809	TPV809Z-3STR	SOT-23	Tape and Reel, 3,000	V2Z
TPV809	TPV809R-3STR	SOT-23	Tape and Reel, 3,000	V2R
TPV809	TPV809S-3STR	SOT-23	Tape and Reel, 3,000	V2S
TPV809	TPV809T-3STR	SOT-23	Tape and Reel, 3,000	V2T
TPV809	TPV809M-3STR	SOT-23	Tape and Reel, 3,000	V2M
TPV809	TPV809L-3STR	SOT-23	Tape and Reel, 3,000	V2L

Model Name	Order Number	Package	Transport Media, Quantity	Package Marking
TPV810	TPV810V-3TR	SOT-23-3	Tape and Reel, 3,000	V3V
TPV810	TPV810W-3TR	SOT-23-3	Tape and Reel, 3,000	V3W
TPV810	TPV810Y-3TR	SOT-23-3	Tape and Reel, 3,000	V3Y
TPV810	TPV810Z-3TR	SOT-23-3	Tape and Reel, 3,000	V3Z
TPV810	TPV810R-3TR	SOT-23-3	Tape and Reel, 3,000	V3R
TPV810	TPV810S-3TR	SOT-23-3	Tape and Reel, 3,000	V3S

TPV810	TPV810T-3TR	SOT-23-3	Tape and Reel, 3,000	V3T
TPV810	TPV810M-3TR	SOT-23-3	Tape and Reel, 3,000	V3M
TPV810	TPV810L-3TR	SOT-23-3	Tape and Reel, 3,000	V3L
TPV810	TPV810V-3STR	SOT-23	Tape and Reel, 3,000	V3V
TPV810	TPV810W-3STR	SOT-23	Tape and Reel, 3,000	V3W
TPV810	TPV810Y-3STR	SOT-23	Tape and Reel, 3,000	V3Y
TPV810	TPV810Z-3STR	SOT-23	Tape and Reel, 3,000	V3Z
TPV810	TPV810R-3STR	SOT-23	Tape and Reel, 3,000	V3R
TPV810	TPV810S-3STR	SOT-23	Tape and Reel, 3,000	V3S
TPV810	TPV810T-3STR	SOT-23	Tape and Reel, 3,000	V3T
TPV810	TPV810M-3STR	SOT-23	Tape and Reel, 3,000	V3M
TPV810	TPV810L-3STR	SOT-23	Tape and Reel, 3,000	V3L

Absolute Maximum Ratings

Table 3

Parameter	Rating
VCC	-0.3 V to 6 V
Output Current (source or sink current for Push-pull, and sink current for open drain)	20 mA
Operating Temperature Range	-40°C to 125°C
Storage Temperature Range	-65°C to 150°C
Maximum Junction Temperature	150°C
Lead Temperature (Soldering, 10 sec)	260°C

* **Note:** Stresses beyond those listed under Absolute Maximum Ratings may cause permanent damage to the device. Exposure to any Absolute Maximum Rating condition for extended periods may affect device reliability and lifetime.

ESD, Electrostatic Discharge Protection

Table 4

Symbol	Parameter	Condition	Minimum Level	Unit
HBM	Human Body Model ESD	ANSI/ESDA/JEDEC JS-001	4000	V
CDM	Charged Device Model ESD	ANSI/ESDA/JEDEC JS-002	2000	V

Electrical Characteristics

VCC = 1.53 V to 5.5 V; TA = -40°C to +125°C, unless otherwise noted.

Table 5

TPV803/809/810V;			SPEC		
Parameter	Test conditions	Unit	Min	Typ	Max
VCC Operating Voltage Range		V	1		5.5
Supply Current	VCC=1.8V	μA		2.2	10
	VCC=5V	μA		6	15
RESET THRESHOLD VOLTAGE					
TPV8xxV	Vth	V	1.51	1.58	1.63
TPV8xxW	Vth	V	1.62	1.67	1.71
TPV8xxY	Vth	V	2.12	2.19	2.25
TPV8xxZ	Vth	V	2.25	2.32	2.38
TPV8xxR	Vth	V	2.55	2.63	2.70
TPV8xxS	Vth	V	2.85	2.93	3.00
TPV8xxT	Vth	V	3.00	3.08	3.15
TPV8xxM	Vth	V	4.25	4.38	4.5
TPV8xxL	Vth	V	4.5	4.63	4.75
RESET THRESHOLD TEMPERATURE COEFFICIENT		ppm/°C		60	
RESET THRESHOLD HYSTERESIS		mV		2 × VTH	
VCC TO RESET DELAY	VTH - VCC = 100 mV	μs		20	
RESET TIMEOUT PERIOD		ms	140	200	280
RESET OUTPUT VOLTAGE VOL (Push-Pull and open drain)	VCC ≥ 1 V, ISINK = 50 μA	V			0.3
RESET OUTPUT VOLTAGE VOL (Push-Pull and open drain)	Vcc=Vth, Isink=1.2mA Vth≥2.63V	V			0.3
RESET OUTPUT VOLTAGE VOL (Push-Pull and open drain)	Vcc=Vth, Isink=3.2mA Vth≥4V	V			0.4
RESET OUTPUT VOLTAGE VOH (Push-Pull Only)	VCC ≥ 1.8 V, ISOURCE = 200 μA	V	0.8 × VCC		
RESET OUTPUT VOLTAGE VOH (Push-Pull Only)	VCC=Vth, ISOURCE = 500 μA Vth≥2.63V	V	0.8 × VCC		
RESET OUTPUT VOLTAGE VOH (Push-Pull Only)	VCC=Vth, ISOURCE = 800 μA Vth≥4V	V	VCC-1.5V		

Typical Performance Characteristics

All test condition is VDD = 3.3V, TA = +25°C, unless otherwise noted.

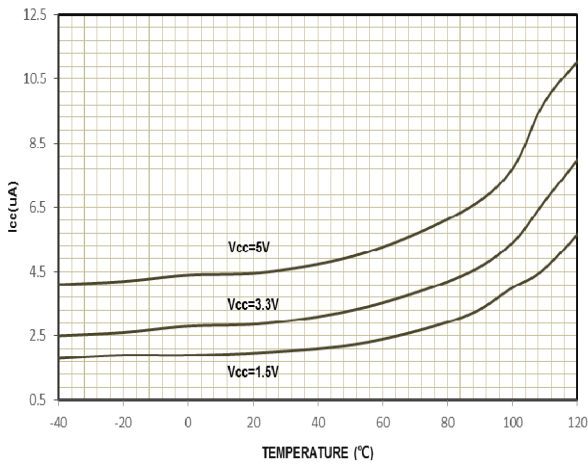

Figure 2. Supply Current vs. Temperature

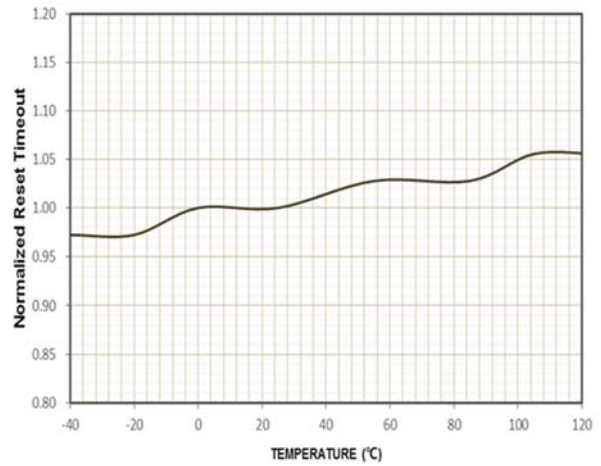

Figure 3. Normalized RESET Timeout Period vs. Temperature

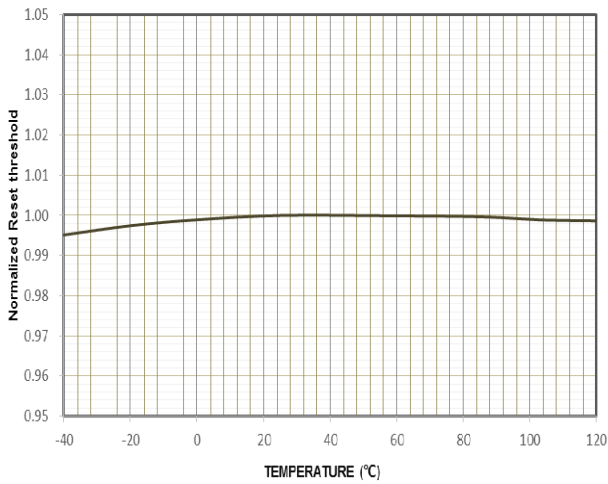

Figure 4. Normalized RESET Threshold vs. Temperature

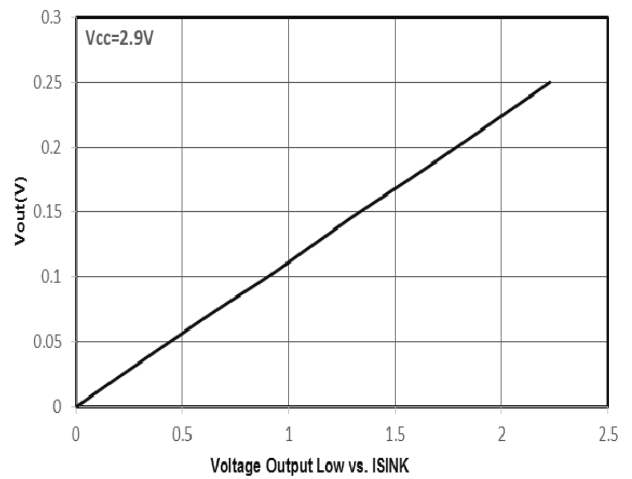

Figure 5. Voltage Output Low vs. ISINK (TPV809)

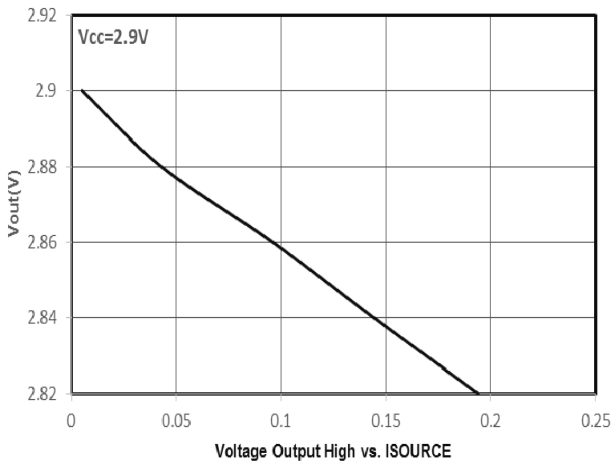

Figure 6. Voltage Output Low vs. ISOURCE

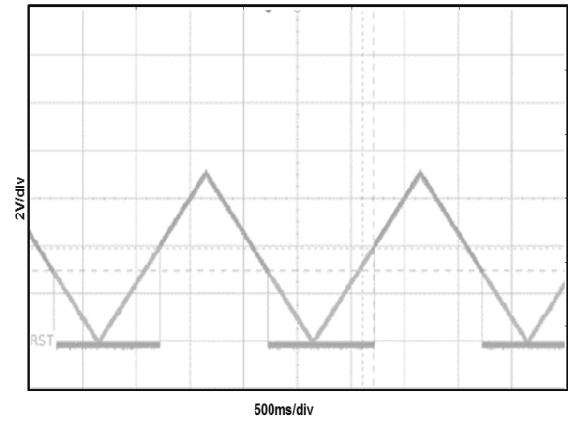

Figure 7. RESET Output Voltage vs. Supply Voltage

Theory of Operation

The TPV803/809/810 provides supply voltage supervision function.

A reset signal is asserted when the supply voltage is below a preset threshold. In addition, the TPV803/809/810 allows supply voltage stabilization with a fixed timeout before the reset de-asserts after the supply voltage rises above the threshold.

RESET OUTPUT

The TPV803/809 feature an active-low open-drain or push-pull output. The TPV8810 features an active-high push-pull output. For active-low output, the reset signal is guaranteed to be logic low for VCC down to 1 V. For active-high output, the reset signal is guaranteed to be logic low for VCC down to 1 V. The reset output is

asserted when VCC is below the reset threshold (V_{TH}), Reset remains asserted for the duration of the reset active timeout period (t_{RP}) after VCC rises above the reset threshold. Figure 10 shows the reset outputs.

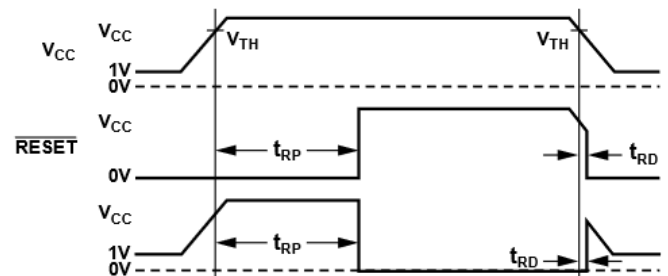
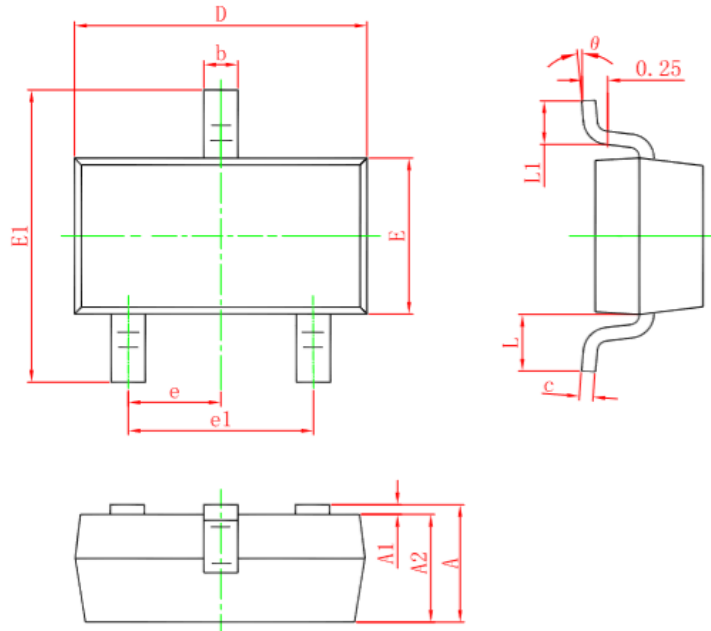

Figure 10. Reset Timing Diagram

Package Outline Dimensions

SOT-23



Symbol	Dimensions In Millimeters		Dimensions In Inches	
	Min.	Max.	Min.	Max.
A	0.900	1.150	0.035	0.045
A1	0.000	0.100	0.000	0.004
A2	0.900	1.050	0.035	0.041
b	0.300	0.500	0.012	0.020
c	0.080	0.150	0.003	0.006
D	2.800	3.000	0.110	0.118
E	1.200	1.400	0.047	0.055
E1	2.250	2.550	0.089	0.100
e	0.950 TYP.		0.037 TYP.	
e1	1.800	2.000	0.071	0.079
L	0.550 REF.		0.022 REF.	
L1	0.300	0.500	0.012	0.020
θ	0°	8°	0°	8°

SOT-23-3

SOT-23-3L (14RA) PACKAGE OUTLINE DIMENSIONS

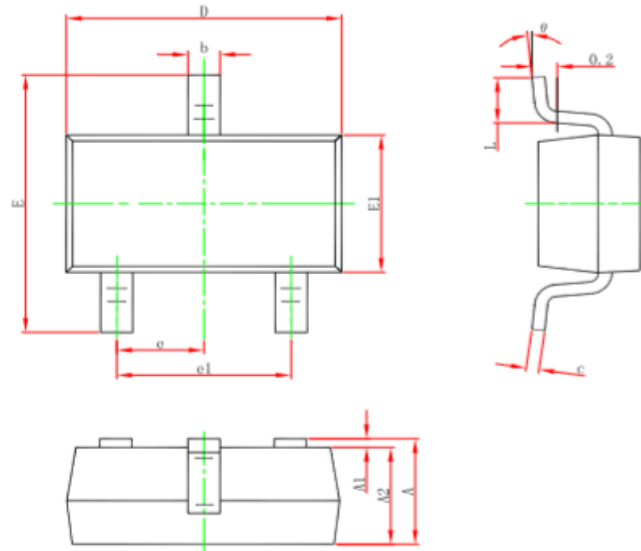

Symbol	Dimensions In Millimeters		Dimensions In Inches	
	Min	Max	Min	Max
A	1.050	1.250	0.041	0.049
A1	0.000	0.100	0.000	0.004
A2	1.050	1.150	0.041	0.045
b	0.300	0.500	0.012	0.020
c	0.100	0.200	0.004	0.008
D	2.820	3.020	0.111	0.119
E1	1.500	1.700	0.059	0.067
E	2.650	2.950	0.104	0.116
e	0.950(BSC)		0.037(BSC)	
e1	1.800	2.000	0.071	0.079
L	0.300	0.600	0.012	0.024
θ	0°	8°	0°	8°

3PEAK and the 3PEAK logo are registered trademarks of 3PEAK INCORPORATED. All other trademarks are the property of their respective owners.

X-ON Electronics

Largest Supplier of Electrical and Electronic Components

Click to view similar products for [Supervisory Circuits](#) category:

Click to view products by [3PEAK](#) manufacturer:

Other Similar products are found below :

[NCP304LSQ40T1G](#) [CAT1161LI-25-G](#) [CAT853STBI-T3](#) [TC54VN2402EMB713](#) [MCP1316MT-45GE/OT](#) [MCP1316MT-23LI/OT](#)
[MCP1316T-26LE/OT](#) [DS1232L](#) [NCV302HSN45T1G](#) [MCP1316T-23LI/OT](#) [PT7M6130NLTA3EX](#) [S-1000N28-I4T1U](#) [CAT1161LI-28-G](#)
[MCP1321T-29AE/OT](#) [MCP1320T-31KE/OT](#) [S-1000N23-I4T1U](#) [S-1000N19-I4T1U](#) [CAT824UTDI-GT3](#) [TC54VC2502ECB713](#) [MCP1317T-25LE/OT](#) [PT7M6133NLTA3EX](#) [PT7M6127NLTA3EX](#) [BD48E23G-TR](#) [BD48E49G-TR](#) [BD48E52G-TR](#) [MP6412GQGU-Z](#)
[XC61GN2502HR-G](#) [HG810RM3/TR](#) [ME2808A33XG](#) [ME2801A33M3G](#) [SGM809B-RXN3LG/TR](#) [HT7033S](#) [UM803RS](#) [UM805RE](#)
[BL8506-40CRM](#) [SSP61CN1902MR](#) [MAX809C263NR](#) [HE61CN2402MR](#) [SL61CC2702MR-G](#) [UM810MS](#) [MAX809C293NR](#)
[MAX809C308NR](#) [HE61CN2702MR](#) [UM811SE](#) [XC61CN1902MR](#) [BD48K34G-TL](#) [BL8506-20CRM](#) [XC61CC1502MR](#) [XC61CN1802MR](#)
[BL8509CCB3TR263DC](#)