

Features

- Supply Voltage: 3V to 36V
- Low Supply Current: 100µA per channel
- Input Common-Mode Voltage Range Includes Ground
- Can Work as Comparator
- Rail to Rail Output
- Bandwidth: 0.9 MHz
- Slew Rate: 0.5V/µs
- Excellent EMI Suppress Performance: 71dB at 1GHz
- Offset Voltage: ±3mV Maximum
- Offset Voltage Temperature Drift: 7 µV/°C
- -40°C to 125°C Operation Temperature Range

Applications

- Power Module
- Sensor Interface
- Motor Control
- Audio

Description

The LM2904A/2902A series amplifiers are newest high supply voltage amplifiers with low offset, low power and stable frequency response. They incorporate 3PEAK’s proprietary and patented design techniques to achieve very good AC performance with 0.9MHz bandwidth, 0.5V/µs slew rate and maximum 3mV offset while drawing only 100µA of quiescent current per amplifier. The input common-mode voltage range extends to V-, and the outputs swing rail-to-rail. The LM2904A/2902A family can be used as plug-in replacements for many commercially available op-amps to reduce power and improve input/output range and performance.

The combination of features makes the LM2904A/2902A ideal choices for power module, industrial control, motor control and audio application.

Pin Configuration

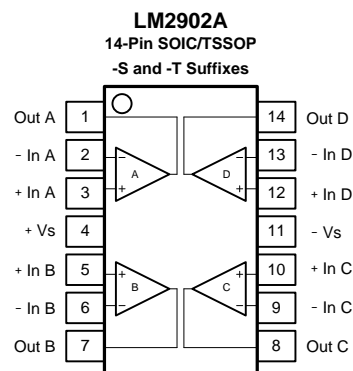
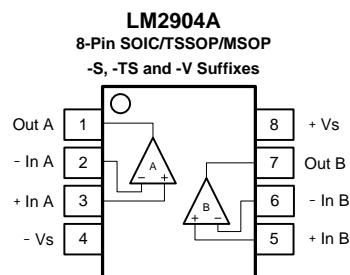

Table of Contents

Features	1
Applications.....	1
Description.....	1
Pin Configuration	1
Table of Contents	2
Revision History	3
Order Information.....	3
Absolute Maximum Ratings ^{Note 1}	4
ESD Rating.....	4
Thermal Information	4
Electrical Characteristics	5
Typical Performance Characteristics	7
Tape and Reel Information	9
Package Outline Dimensions.....	10
SOIC-8	10
TSSOP-8.....	11
MSOP-8	12
SOIC-14	13
TSSOP-14.....	13

Revision History

Date	Revision	Notes
2018/3/21	Rev.Pre	Pre-Release Version
2018/10/30	Rev.0	Initial Version
2018/11/11	Rev.0.01	Add LM2902AL1-SR, Correct the condition of VOL,VOH to VS/2, Add mark information.
2019/1/9	Rev.0.02	Update Package Outline Dimension
2019/6/26	Rev.0.03	Add temperature limit of VOL, VOH, Isc Update Package Dimension
2019/8/16	Rev.0.04	Update the description of VOL, VOH in Electrical Characteristics: Remove VOL, VOH, Maximum Output Swing -> Output Voltage Swing from Positive and Negative Rail; Output Voltage Swing Low-> Output Voltage Swing from Negative Rail

Order Information

Order Number	Operating Temperature Range	Package	Marking Information	MSL	Transport Media, Quantity
LM2904A-SR	-40 to 125°C	8-Pin SOIC	2904A	3	Tape and Reel, 4000
LM2904AL1-SR	-40 to 125°C	8-Pin SOIC	2904A	1	Tape and Reel, 4000
LM2904A-TSR	-40 to 125°C	8-Pin TSSOP	2904A	3	Tape and Reel, 3000
LM2904A-VR	-40 to 125°C	8-Pin MSOP	2904A	3	Tape and Reel, 3000
LM2902A-SR	-40 to 125°C	14-Pin SOIC	2902A	3	Tape and Reel, 2500
LM2902AL1-SR	-40 to 125°C	14-Pin SOIC	2902A	1	Tape and Reel, 2500
LM2902A-TR	-40 to 125°C	14-Pin TSSOP	2902A	3	Tape and Reel, 3000

Absolute Maximum Ratings ^{Note 1}

Parameters	Rating
Supply Voltage, (+V _S)– (-V _S)	40 V
Input Voltage	(-V _S) – 0.3 to (+V _S) + 0.3
Differential Input Voltage	(+V _S) - (-V _S)
Input Current: +IN, –IN ^{Note 2}	±10mA
Output Short-Circuit Duration ^{Note 3}	Infinite
Maximum Junction Temperature	150°C
Operating Temperature Range	–40 to 125°C
Storage Temperature Range	–65 to 150°C
Lead Temperature (Soldering, 10 sec)	260°C

Note 1: Stresses beyond those listed under Absolute Maximum Ratings may cause permanent damage to the device. Exposure to any Absolute Maximum Rating condition for extended periods may affect device reliability and lifetime.

Note 2: The inputs are protected by ESD protection diodes to each power supply. If the input extends more than 300mV beyond the power supply, the input current should be limited to less than 10mA.

Note 3: A heat sink may be required to keep the junction temperature below the absolute maximum. This depends on the power supply voltage and how many amplifiers are shorted. Thermal resistance varies with the amount of PC board metal connected to the package. The specified values are for short traces connected to the leads.

ESD Rating

Symbol	Parameter	Condition	Minimum Level	Unit
HBM	Human Body Model ESD	ANSI/ESDA/JEDEC JS-001	3	kV
CDM	Charged Device Model ESD	ANSI/ESDA/JEDEC JS-002	2	kV

Thermal Information

Package Type	θ_{JA}	θ_{JC}	Unit
8-Pin SOIC	158	43	°C/W
8-Pin TSSOP	191	44	°C/W
8-Pin MSOP	210	45	°C/W
14-Pin SOIC	120	36	°C/W
14-Pin TSSOP	180	35	°C/W

Electrical Characteristics

All test condition is $V_S = 30V$, $T_A = 25^\circ C$, $R_L = 10k\Omega$, $C_L = 100pF$, unless otherwise noted.

Symbol	Parameter	Conditions	T_A	Min	Typ	Max	Unit
Power Supply							
V_S	Supply Voltage Range			3		36	V
I_Q	Quiescent Current per Amplifier	$V_S = 30V$			110	200	μA
			Operating Range			250	μA
		$V_S = 5V$			100	150	μA
			Operating Range			200	μA
PSRR	Power Supply Rejection Ratio	$V_S = 5V$ to $36V$		85	120		dB
			Operating Range	80			dB
Input Characteristics							
V_{OS}	Input Offset Voltage	$V_S = 30V$, $V_{CM} = 0V$ to $28V$		-3	0.1	3	mV
			Operating Range	-7		7	mV
		$V_S = 5V$, $V_{CM} = 0V$ to $3V$		-3	0.1	3	mV
			Operating Range	-7		7	mV
$V_{OS\ TC}$	Input Offset Voltage Drift		Operating Range		7		$\mu V/^\circ C$
I_B	Input Bias Current				60		μA
			Operating Range			600	
I_{OS}	Input Offset Current				60		μA
I_{IN}	Different Input Current	$V_S = 36V$, $V_{ID} = 36V$			5		nA
		$V_S = 36V$, $V_{ID} = 36V$	Operating Range		20		nA
C_{IN}	Input Capacitance	Differential Mode			5		pF
		Common Mode			5		pF
A_v	Open-loop Voltage Gain			95	110		dB
			Operating Range	90			dB
V_{CMR}	Common-mode Input Voltage Range		Operating Range	(V-)		(V+) - 2	V
CMRR	Common Mode Rejection Ratio	$V_{CM} = 0V$ to $28V$		75	120		dB
			Operating Range	70	90		dB
Output Characteristics							
	Output Voltage Swing from Positive and Negative Rail	$R_{LOAD} = 10k\Omega$ to $V_S/2$			200	300	mV
			Operating Range			700	mV
		$R_{LOAD} = 2k\Omega$ to $V_S/2$			1.1	1.3	V
			Operating Range			2	V
	Output Voltage Swing from Negative Rail	$V_S = 5V$, $R_{LOAD} = 10k\Omega$ to $0V$			5	10	mV
I_{SC}	Output Short-Circuit Current			25	30		mA
			Operating Range	15			mA

AC Specifications							
GBW	Gain-Bandwidth Product				0.9		MHz
SR	Slew Rate	G = 1, 2V step			0.5		V/ μ s
t_s	Settling Time, 0.1%	G = 1, 2V step			4		μ s
	Settling Time, 0.01%				5		μ s
PM	Phase Margin	$V_S = 30V, R_L = 1K, C_L = 100pF$			60		$^\circ$
GM	Gain Margin	$V_S = 30V, R_L = 1K, C_L = 100pF$			15		dB
	Channel Separation	f = 1 kHz to 20 kHz			120		dB
Noise Performance							
E_N	Input Voltage Noise	f = 0.1Hz to 10Hz			3		μV_{RMS}
e_N	Input Voltage Noise Density	f = 1kHz			70		nV/ \sqrt{Hz}
i_N	Input Current Noise	f = 1kHz			3		fA/ \sqrt{Hz}
THD+N	Total Harmonic Distortion and Noise	f = 1kHz, G = 1, $R_L = 10k\Omega$, $V_{OUT} = 6V_{RMS}$			0.001		%

Typical Performance Characteristics

$V_S = \pm 15V$, $V_{CM} = 0V$, $R_L = 10k\Omega$, unless otherwise specified.

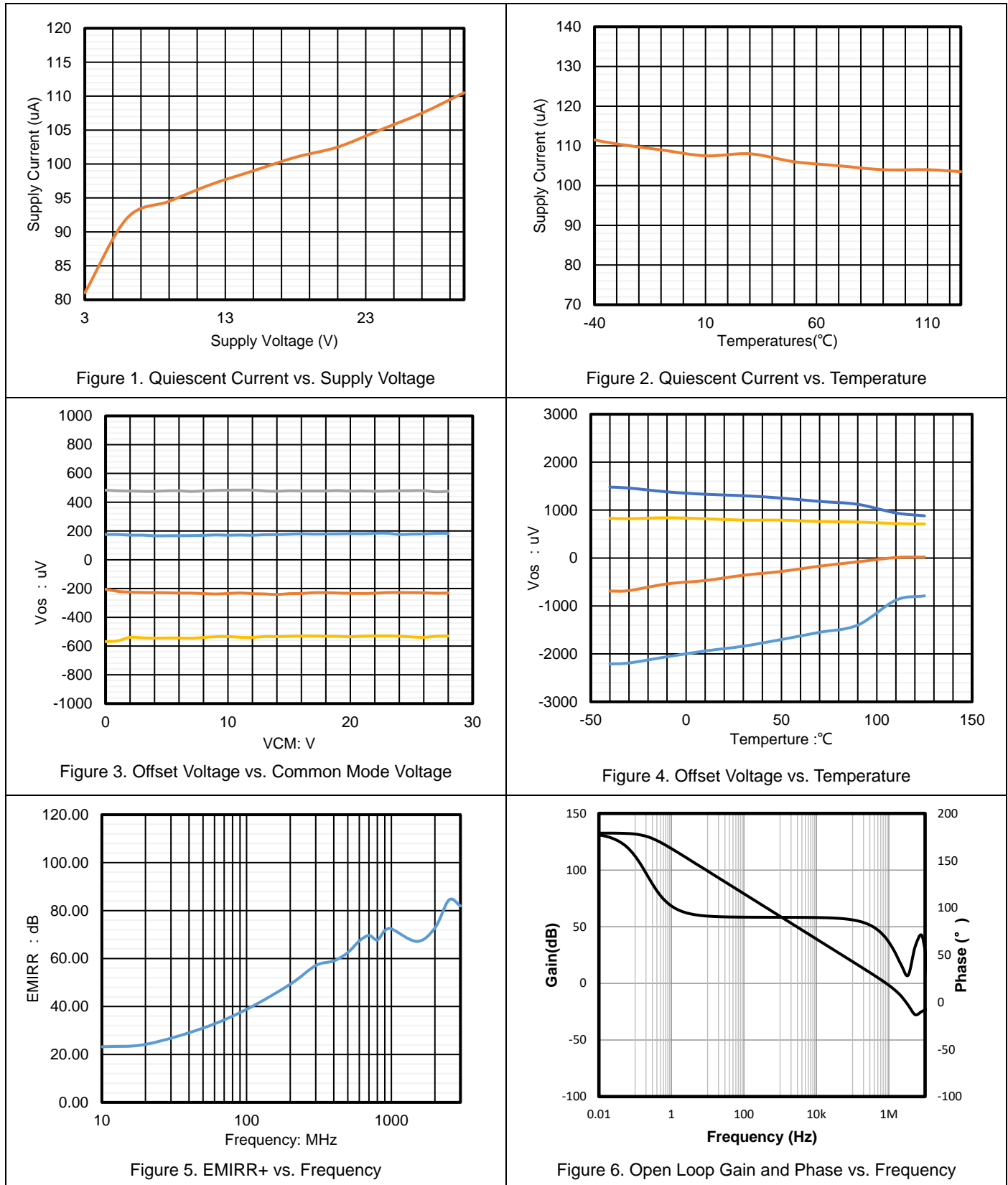

$V_s = \pm 15V$, $V_{CM} = 0V$, $R_L = 10k\Omega$, unless otherwise specified.

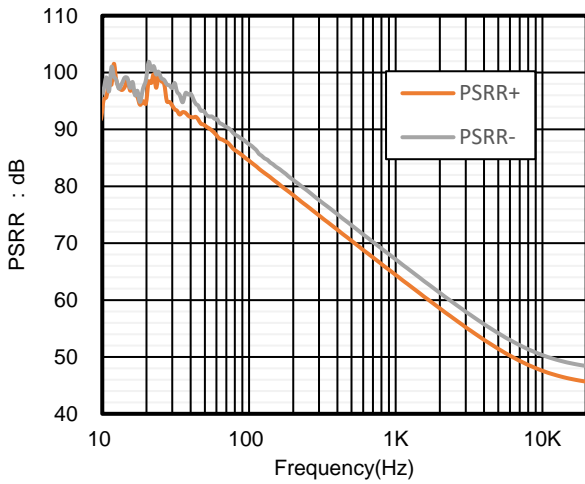

Figure 7. PSRR vs. Frequency

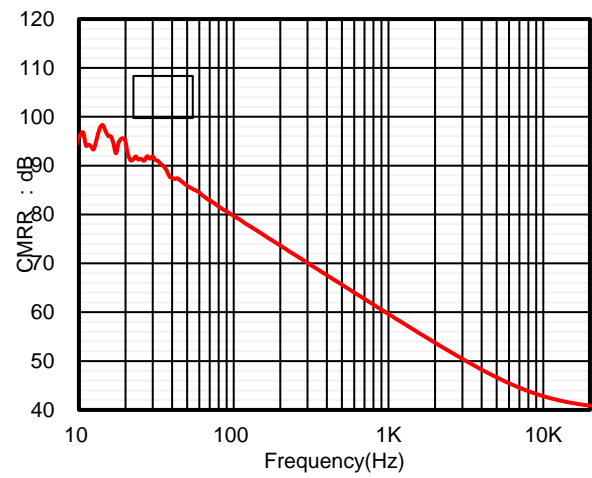

Figure 8. CMRR vs. Frequency

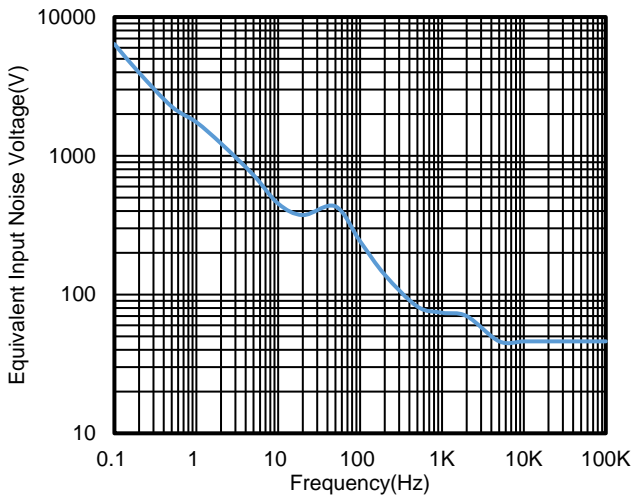

Figure 9. Voltage Noise Spectral Density vs. Frequency

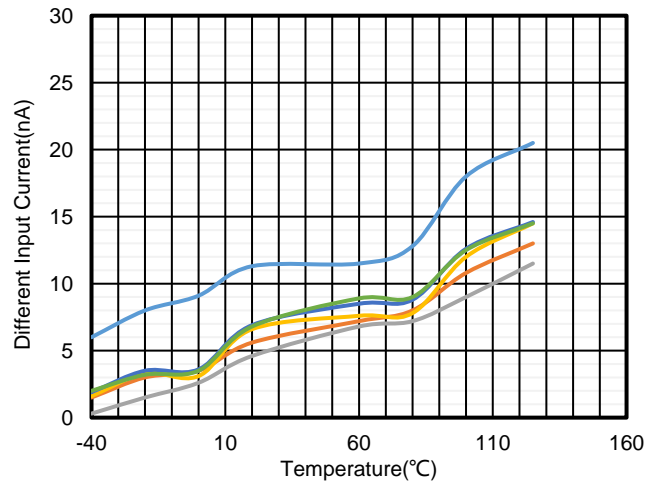
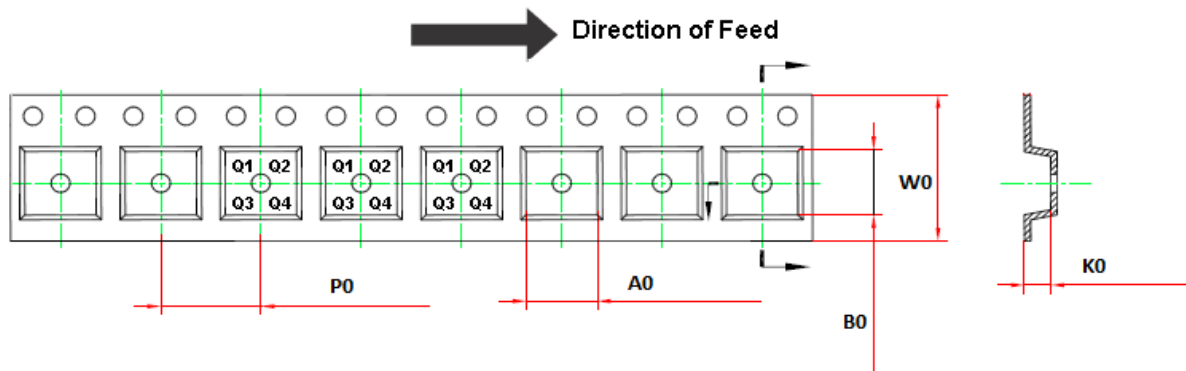
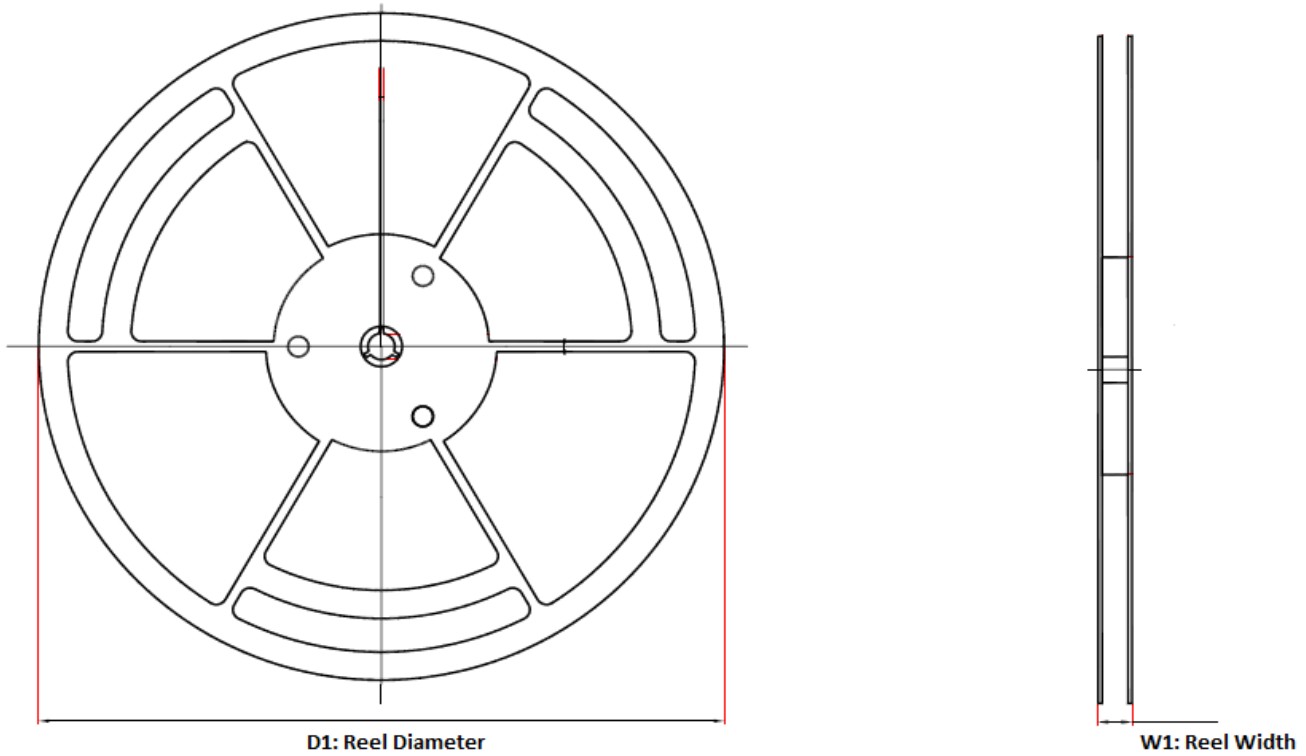
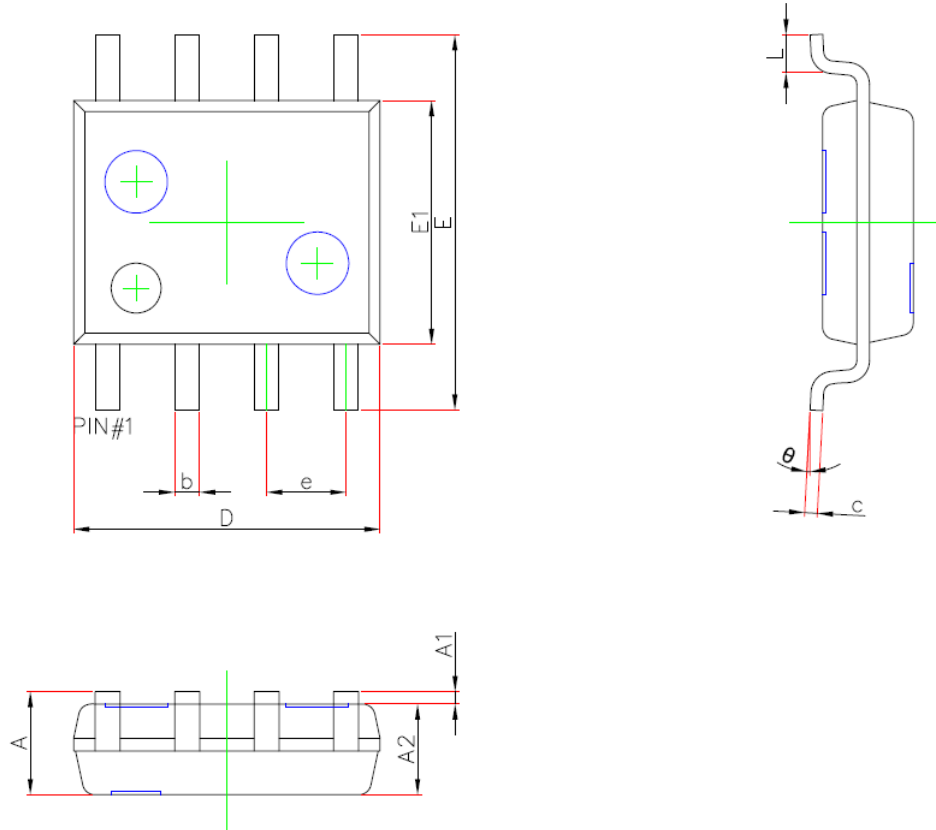

Figure 10. Different Input Current vs. Temperature

Tape and Reel Information



Order Number	Package	D1	W1	A0	B0	K0	P0	W0	Pin1 Quadrant
LM2904A-SR	8-Pin SOIC	330.0	17.6	6.4	5.4	2.1	8.0	12.0	Q1
LM2904AL1-SR	8-Pin SOIC	330.0	17.6	6.4	5.4	2.1	8.0	12.0	Q1
LM2904A-VR	8-Pin MSOP	330.0	17.6	5.2	3.3	1.5	8.0	12.0	Q1
LM2904A-TSR	8-Pin TSSOP	330.0	17.6	6.8	3.3	1.2	8.0	12.0	Q1
LM2902A-SR	14-Pin SOIC	330.0	21.6	6.5	9.0	2.1	8.0	16.0	Q1
LM2902AL1-SR	14-Pin SOIC	330.0	21.6	6.5	9.0	2.1	8.0	16.0	Q1
LM2902A-TR	14-Pin TSSOP	330.0	17.6	6.8	5.4	1.2	8.0	12.0	Q1

Package Outline Dimensions
SOIC-8

Symbol	Dimensions In Millimeters		Dimensions In Inches	
	Min.	Max.	Min.	Max.
A	1.350	1.750	0.053	0.069
A1	0.100	0.250	0.004	0.010
A2	1.350	1.550	0.053	0.061
b	0.330	0.510	0.013	0.020
c	0.170	0.250	0.007	0.010
D	4.700	5.100	0.185	0.201
E	5.800	6.200	0.228	0.244
E1	3.800	4.000	0.150	0.157
e	1.270(BSC)		0.050(BSC)	
L	0.400	0.800	0.016	0.031
θ	0°	8°	0°	8°

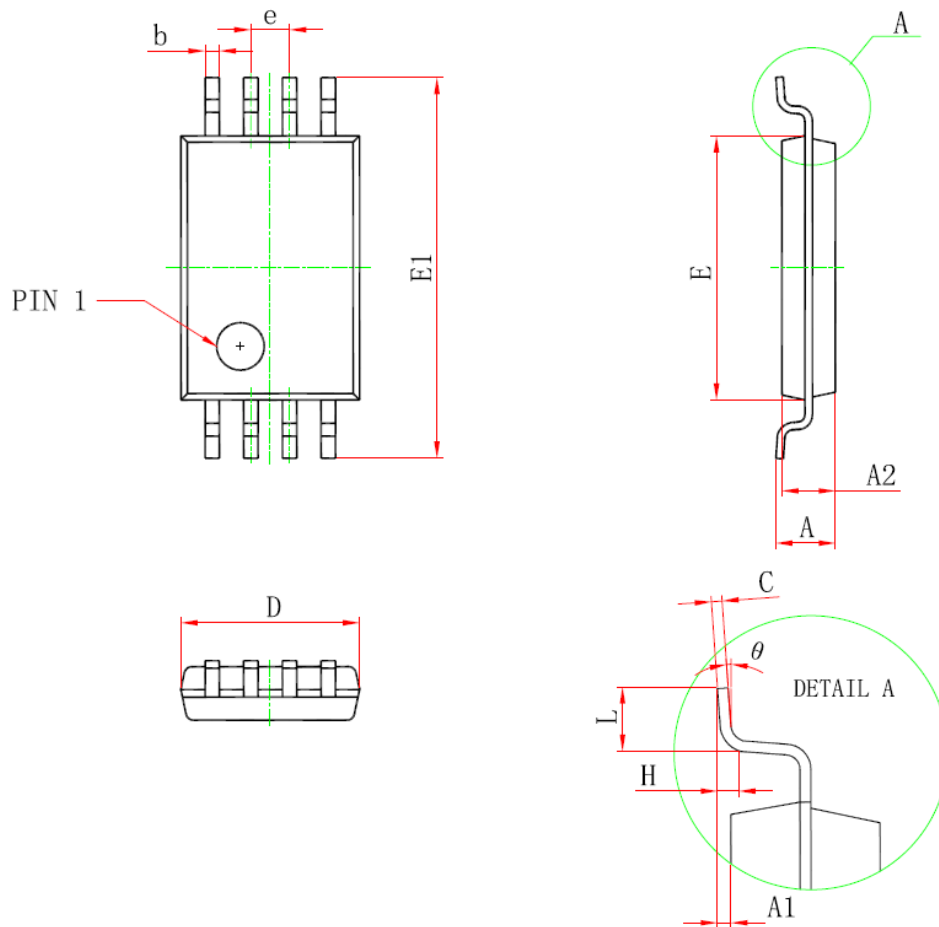
TSSOP-8

Symbol	Dimensions In Millimeters		Dimensions In Inches	
	Min	Max	Min	Max
D	2.900	3.100	0.114	0.122
E	4.300	4.500	0.169	0.177
b	0.190	0.300	0.007	0.012
c	0.090	0.200	0.004	0.008
E1	6.250	6.550	0.246	0.258
A		1.200		0.047
A2	0.800	1.000	0.031	0.039
A1	0.050	0.150	0.002	0.006
e	0.65 (BSC)		0.026 (BSC)	
L	0.500	0.700	0.020	0.028
H	0.25(TYP)		0.01(TYP)	
θ	1°	7°	1°	7°

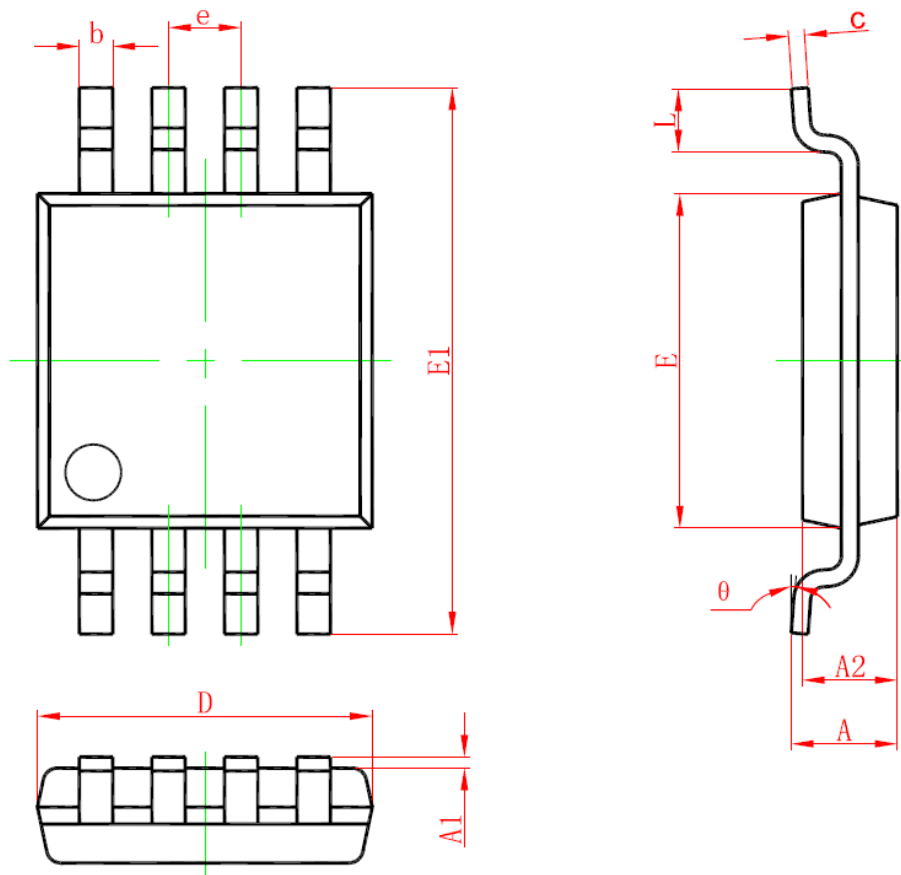
MSOP-8

Symbol	Dimensions In Millimeters		Dimensions In Inches	
	Min	Max	Min	Max
A	0.820	1.100	0.032	0.043
A1	0.020	0.150	0.001	0.006
A2	0.750	0.950	0.030	0.037
b	0.250	0.380	0.010	0.015
c	0.090	0.230	0.004	0.009
D	2.900	3.100	0.114	0.122
e	0.650(BSC)		0.026(BSC)	
E	2.900	3.100	0.114	0.122
E1	4.750	5.050	0.187	0.199
L	0.400	0.800	0.016	0.031
θ	0°	6°	0°	6°

SOIC-14

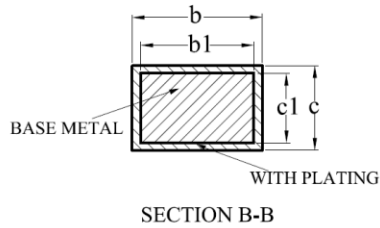
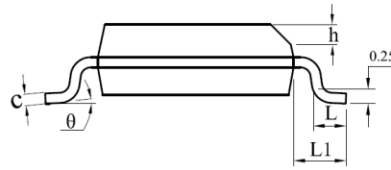
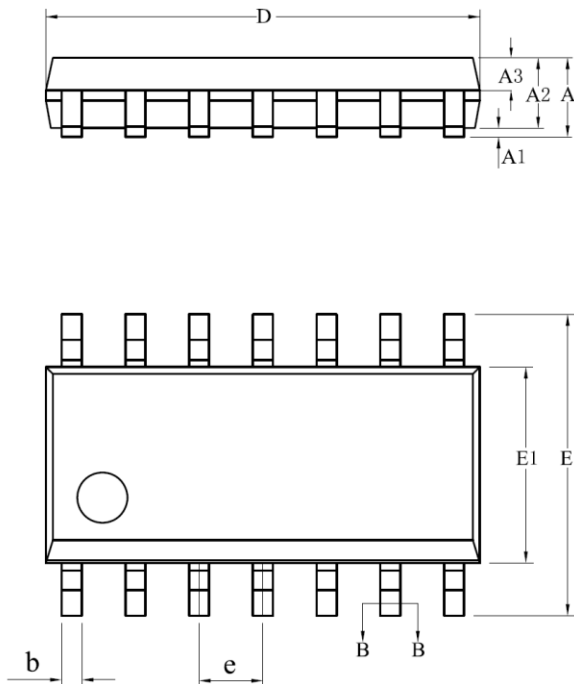

SYMBOL	MILLIMETER		
	MIN	NOM	MAX
A	—	—	1.75
A1	0.05	—	0.225
A2	1.30	1.40	1.50
A3	0.60	0.65	0.70
b	0.39	—	0.47
b1	0.38	0.41	0.44
c	0.20	—	0.24
c1	0.19	0.20	0.21
D	8.55	8.65	8.75
E	5.80	6.00	6.20
E1	3.80	3.90	4.00
e	1.27BSC		
h	0.25	—	0.50
L	0.50	—	0.80
L1	1.05REF		
θ	0	—	8°

TSSOP-14

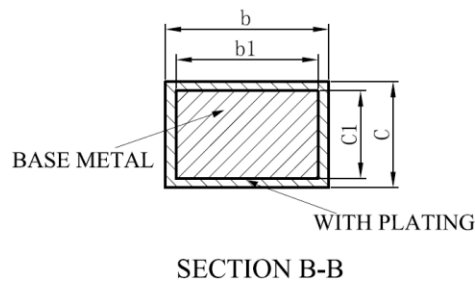
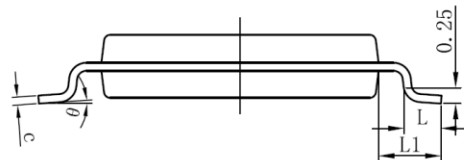
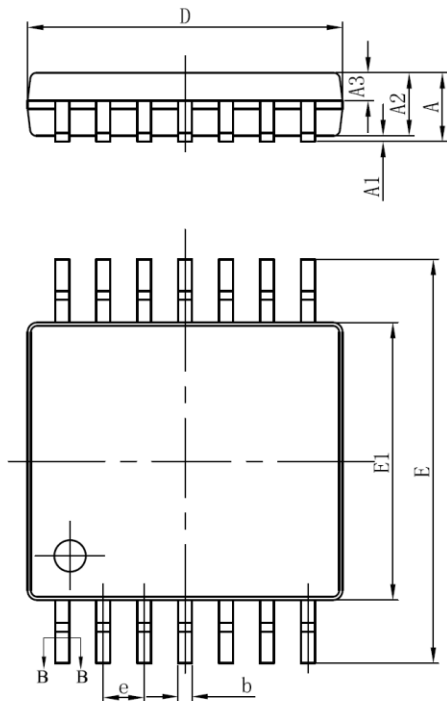

SYMBOL	MILLIMETER		
	MIN	NOM	MAX
A	—	—	1.20
A1	0.05	—	0.15
A2	0.90	1.00	1.05
A3	0.39	0.44	0.49
b	0.20	—	0.28
b1	0.19	0.22	0.25
c	0.13	—	0.17
c1	0.12	0.13	0.14
D	4.90	5.00	5.10
E1	4.30	4.40	4.50
E	6.20	6.40	6.60
e	0.65BSC		
L	0.45	0.60	0.75
L1	1.00BSC		
θ	0	—	8°

 **3PEAK and the 3PEAK logo are registered trademarks of 3PEAK INCORPORATED. All other trademarks are the property of their respective owners.**

X-ON Electronics

Largest Supplier of Electrical and Electronic Components

Click to view similar products for [Operational Amplifiers - Op Amps](#) category:

Click to view products by [3PEAK](#) manufacturer:

Other Similar products are found below :

[OPA2991IDSGR](#) [OPA607IDCKT](#) [007614D](#) [633773R](#) [635798C](#) [635801A](#) [702115D](#) [709228FB](#) [741528D](#) [NCV33072ADR2G](#)
[SC2902DTBR2G](#) [SC2903DR2G](#) [SC2903VDR2G](#) [LM258AYDT](#) [LM358SNG](#) [430227FB](#) [430228DB](#) [460932C](#) [AZV831KTR-G1](#) [409256CB](#)
[430232AB](#) [LM2904DR2GH](#) [LM358YDT](#) [LT1678IS8](#) [042225DB](#) [058184EB](#) [070530X](#) [SC224DR2G](#) [SC239DR2G](#) [SC2902DG](#)
[SCYA5230DR2G](#) [714228XB](#) [714846BB](#) [873836HB](#) [MIC918YC5-TR](#) [TS912BIYDT](#) [NCS2004MUTAG](#) [NCV33202DMR2G](#)
[M38510/13101BPA](#) [NTE925](#) [SC2904DR2G](#) [SC358DR2G](#) [LM358EDR2G](#) [AZV358MTR-G1](#) [AP4310AUMTR-AG1](#) [HA1630D02MMEL-E](#)
[NJM358CG-TE2](#) [HA1630S01LPEL-E](#) [LM324AWPT](#) [HA1630Q06TELL-E](#)