

370-002
Submersible Cable Sealing Backshell
 with Strain Relief
 Low Profile - Direct Coupling

**CONNECTOR
 DESIGNATORS**
A-B*-C-D-E-F
G-H-J-K-L-S

* Conn. Desig. B See Note 5
**DIRECT
 COUPLING**



STYLE 2
 (STRAIGHT
 See Note 1)

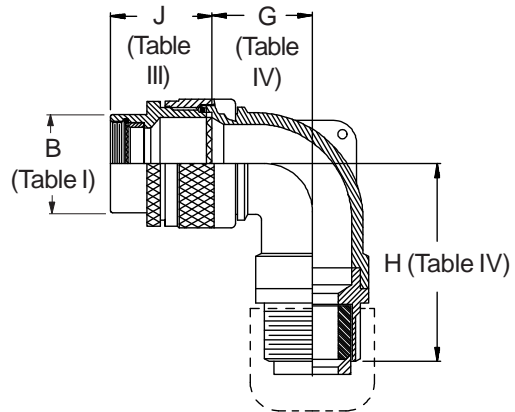

STYLE H
 Heavy Duty
 (Table X)

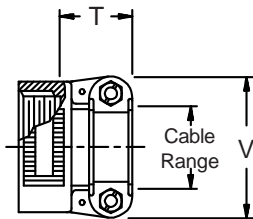

STYLE A
 Medium Duty
 (Table XI)

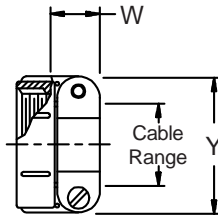

STYLE M
 Medium Duty
 (Table XI)

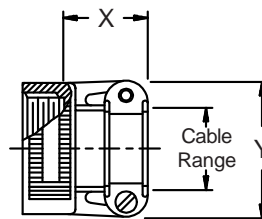

STYLE D
 Medium Duty
 (Table XI)

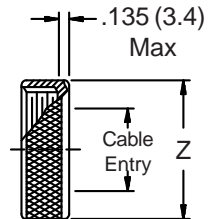

370-002
Submersible Cable Sealing Backshell
 with Strain Relief
 Low Profile - Direct Coupling



TABLE III: FRONT ADAPTER

Shell Size	J Max - Conn. Designator		
	A-E-F		
	J-H-L-S	D-B-G-K	C
08/09	1.180 (30.0)	1.440 (36.6)	
10/11	1.180 (30.0)	1.440 (36.6)	
12/13	1.180 (30.0)	1.440 (36.6)	1.735 (44.1)
14/15	1.180 (30.0)	1.440 (36.6)	1.915 (48.6)
16/17	1.380 (35.0)	1.560 (39.6)	1.915 (48.6)
18/19	1.380 (35.0)	1.560 (39.6)	1.915 (48.6)
20/21	1.380 (35.0)	1.560 (39.6)	1.915 (48.6)
22/23	1.380 (35.0)	1.560 (39.6)	1.915 (48.6)
24/25	1.380 (35.0)	1.560 (39.6)	1.915 (48.6)
28/29	1.610 (40.9)	1.560 (39.6)	1.915 (48.6)
32/33	1.610 (40.9)	1.750 (44.5)	1.915 (48.6)
36	1.610 (40.9)	1.750 (44.5)	1.915 (48.6)
40	1.610 (40.9)	2.190 (55.6)	1.915 (48.6)

See inside back cover fold-out or pages 13 and 14 for unabridged Tables I and II.

TABLE IV: ELBOW DIMENSIONS

Elbow Size	E Max	F Max	G Max	H Max
04	.567 (14.4)	1.399 (35.5)	.636 (16.2)	1.412 (35.9)
06	.630 (16.0)	1.462 (37.1)	.710 (18.0)	1.532 (38.9)
08	.692 (17.6)	1.524 (38.7)	.731 (18.6)	1.552 (39.4)
10	.755 (19.2)	1.957 (49.7)	.825 (21.0)	1.962 (49.8)
12	.848 (21.5)	2.067 (52.5)	.988 (25.1)	2.052 (52.1)
16	1.036 (26.3)	2.254 (57.3)	1.087 (27.6)	2.227 (56.6)
20	1.130 (28.7)	2.463 (62.6)	1.325 (33.7)	2.395 (60.8)
24	1.255 (31.9)	2.503 (63.6)	1.337 (34.0)	2.548 (64.7)
28	1.317 (33.5)	2.598 (66.0)	1.827 (46.4)	2.798 (71.1)
32	1.348 (34.2)	2.813 (71.5)	2.027 (51.5)	2.818 (71.6)

TABLE X: CABLE ENTRY

Dash No.	T Max	V Max	Cable Range	
			Min	Max
04	.780 (19.8)	.957 (24.3)	.125 (3.2)	.312 (7.9)
06	.780 (19.8)	1.145 (29.1)	.250 (6.4)	.437 (11.1)
08	.780 (19.8)	1.332 (33.8)	.387 (9.8)	.562 (14.3)
10	.780 (19.8)	1.332 (33.8)	.350 (8.9)	.625 (15.9)
12	.811 (20.6)	1.551 (39.4)	.500 (12.7)	.750 (19.1)
16	.905 (23.0)	1.770 (45.0)	.625 (15.9)	.937 (23.8)
20	1.092 (27.7)	2.113 (53.7)	.875 (22.2)	1.250 (31.8)
24	1.124 (28.5)	2.363 (60.0)	1.000 (25.4)	1.375 (34.9)
28	1.399 (35.5)	2.770 (70.4)	1.250 (31.8)	1.625 (41.3)
32	1.399 (35.5)	3.020 (76.7)	1.437 (36.5)	1.875 (47.6)

TABLE II: STANDARD FINISHES

GLENNAIR SYMBOL	FINISH
B	Cadmium Plate, Olive Drab
C	Anodize, Black
G	Hard Coat, Anodic
M	Electroless Nickel
NF	Cadmium Plate, Olive Drab Over Electroless Nickel

- When maximum cable entry (page 22) is exceeded, Style 2 will be supplied. (Function S only.)
- Metric dimensions (mm) are indicated in parentheses.
- Cable range is defined as the accommodations range for the wire bundle or

TABLE XI: CABLE ENTRY

Dash No.	W Max	X Max	Y Max	Z Max	Cable Range	
					Min**	Max
03*	.437 (11.1)	.760 (19.3)	.843 (21.4)	.630 (16.0)	.156 (4.0)	.250 (6.4)
04*	.437 (11.1)	.760 (19.3)	.906 (23.0)	.755 (19.2)	.188 (4.8)	.312 (7.9)
06*	.500 (12.7)	.760 (19.3)	1.093 (27.8)	.942 (23.9)	.281 (7.1)	.438 (11.1)
08	.563 (14.3)	.760 (19.3)	1.187 (30.1)	1.067 (27.1)	.387 (9.8)	.562 (14.3)
10	.563 (14.3)	.760 (19.3)	1.281 (32.5)	1.192 (30.3)	.375 (9.5)	.625 (15.9)
12	.563 (14.3)	.760 (19.3)	1.500 (38.1)	1.380 (35.1)	.438 (11.1)	.750 (19.1)
16	.656 (16.7)	1.073 (27.3)	1.719 (43.7)	1.535 (39.0)	.625 (15.9)	.938 (23.8)
20	.656 (16.7)	1.323 (33.6)	2.062 (52.4)	1.848 (46.9)	.875 (22.2)	1.250 (31.8)
24	.656 (16.7)	1.323 (33.6)	2.312 (58.7)	2.255 (57.3)	1.000 (25.4)	1.375 (34.9)
28	1.188 (30.2)	1.572 (39.9)	2.719 (69.1)	2.505 (63.6)	1.250 (31.8)	1.625 (41.3)
32*	1.187 (30.1)	1.572 (39.9)	2.969 (75.4)	2.755 (70.0)	1.437 (36.5)	1.875 (47.6)
40*	1.125 (28.6)	1.572 (39.9)	3.531 (89.7)	3.255 (82.7)	1.875 (47.6)	2.375 (60.3)

* Not available in Style M clamp.

** Not Applicable Style D

- cable. Dimensions shown are not intended for inspection criteria.
- Consult factory for shorter lengths on straight backshells.
 - When using Connector Designator B refer to pages 18 and 19 for part number development.

TABLE I - BACKSHELL INTERFACE DIMENSIONS

CONNECTOR DESIGNATOR											A THREAD*	B	C	D	E
A	C*	D	E	F	G	H	J	K	L	S	REFERENCE	DIA MAX	DIA MAX	DIA MAX	DIA MAX
		08	08	08 [9]				08	08	08	7/16 - 28 UNEF	.590 (15.)	.650 (16.5)	.770 (19.6)	.690 (17.5)
						09 [A]					M12 x 1 - 6H	.650 (16.5)	.770 (19.6)		.940 (24.8)
08							08 [A]	10			1/2 - 20 UNF	.650 (16.5)	.650 (16.5)		.690 (17.5)
											1/2 - 28 UNEF	.650 (16.5)	.770 (19.6)	.770 (19.6)	
03		10	10	10 [11]				11	10	10	9/16 - 24 UNEF	.720 (18.3)	.770 (19.6)	.890 (22.6)	.820 (20.8)
						11 [B]					M15 x 1 - 6H	.770 (19.6)	.820 (20.8)		1.060 (26.9)
10								12 [13]			5/8 - 24 UNEF	.770 (19.6)	.770 (19.6)	.890 (22.6)	.820 (20.8)
								10 [B]			5/8 - 28 UN	.770 (19.6)	.890 (22.6)		
		12		12 [13]					12	12	11/16 - 24 UNEF	.840 (21.3)	.890 (22.6)	1.020 (25.9)	.940 (23.8)
						13 [C]					M18 x 1 - 6H	.890 (22.6)	.940 (23.9)		1.170 (29.7)
12 [7]	12		12		11 [A]			14 [15]			3/4 - 20 UNEF	.970 (24.6)	.940 (23.9)	1.020 (25.9)	.940 (23.8)
		14	14	14 [15]					14	14	13/16 - 20 UNEF	.970 (24.6)	1.020 (29.2)	1.150 (29.2)	1.060 (26.9)
						15 [D]					M22 x 1 - 6H	1.030 (26.2)	1.070 (26.2)		1.290 (32.7)
14 [12]	14				13 [B]			16 [17]			7/8 - 20 UNEF	1.090 (27.7)	1.020 (25.9)	1.150 (29.2)	1.060 (26.9)
								14 [D]			7/8 - 28 UN	1.030 (26.2)	1.150 (29.2)		
		16	16	16 [17]					16	16	15/16 - 20 UNEF	1.090 (27.7)	1.150 (29.2)	1.260 (32.0)	1.170 (29.7)
						17 [E]					M25 x 1 - 6H	1.150 (29.2)	1.210 (30.7)		1.420 (36.1)
16 [19]	16				15 [C]			18			1 - 20 UNEF	1.220 (29.2)	1.210 (30.7)	1.230 (31.2)	1.170 (29.7)
								16 [E]			1 - 28 UN	1.150 (29.2)	1.360 (34.5)		
18 [27]		18	18	18 [19]					18	18	1 1/16 - 18 UNEF	1.220 (31.0)	1.230 (31.2)	1.400 (35.6)	1.290 (32.7)
						19 [F]					M28 x 1 - 6H	1.280 (32.5)	1.360 (34.5)		1.540 (39.1)
	18				17 [D]			20			1 1/8 - 18 UNEF	1.340 (34.0)	1.360 (34.5)	1.360 (34.5)	
								18 [F]			1 1/8 - 28 UN	1.280 (32.5)	1.480 (37.6)		
20 [37]		20	20	20 [21]					20	20	1 3/16 - 18 UNEF	1.340 (34.0)	1.360 (34.5)	1.530 (38.9)	1.420 (36.0)
						21 [G]					M31 x 1 - 6H	1.410 (35.8)	1.480 (37.6)		1.670 (42.4)
	20				19 [E]			22			1 1/4 - 18 UNEF	1.470 (37.3)	1.530 (38.9)	1.480 (37.6)	
								20 [G]			1 1/4 - 28 UN	1.410 (35.8)	1.600 (40.6)		
22		22	22	22 [23]					22	22	1 5/16 - 18 UNEF	1.470 (37.3)	1.480 (37.6)	1.600 (40.6)	1.540 (39.1)
						23 [H]					M34 x 1 - 6H	1.530 (38.9)	1.600 (40.6)		2.010 (51.1)
	22							24			1 3/8 - 18 UNEF	1.590 (40.4)		1.600 (40.6)	
								22 [H]			1 3/8 - 28 UN	1.530 (38.9)	1.730 (43.9)		
24		24	24	24 [25]	23 [F]				24	24	1 7/16 - 18 UNEF	1.590 (40.4)	1.730 (43.9)	1.940 (49.3)	1.660 (42.2)
						25 [J]					M37 x 1 - 6H	1.660 (42.2)	1.700 (43.2)		2.120 (53.8)
61								24 [J]			1 1/2 - 18 UNEF	1.660 (42.2)	1.670 (42.4)		
											1 1/2 - 28 UN	1.660 (42.2)	1.940 (49.3)		
					25 [G]						1 9/16 - UNEF		1.820 (46.2)		
	24							28			1 5/8 - UNEF	1.840 (46.7)		1.940 (49.3)	
28											1 3/4 - 18 UNS	1.970 (50.0)	1.970 (50.0)		2.010 (51.1)
	28				29 [H]			32			1 7/8 - 16 UN	2.090 (53.1)	2.190 (55.6)	2.190 (55.6)	
32											2 - 18 UNS	2.280 (57.9)	2.220 (56.4)		2.260 (57.4)
	32				33 [J]						2 1/16 - 16 UNS	2.340 (59.4)	2.440 (62.0)	2.440 (62.0)	
								36			2 1/8 - 16 UN	2.340 (59.4)		2.440 (62.0)	
36											2 1/4 - 16 UN	2.530 (64.3)	2.47 (62.7)		2.530 (64.3)
	36										2 5/16 - 16 UNS	2.590 (65.8)		2.690 (68.3)	
								40			2 3/8 - 16 UN	2.590 (65.8)		2.690 (68.3)	
40											2 1/2 - 16 UN	2.780 (70.6)	2.720 (69.1)		3.040 (77.2)
	40										2 5/8 - 16 UN	2.910 (73.9)		2.930 (74.4)	
44											2 3/4 - 16 UN	3.030 (77.0)	2.970 (75.4)		
	44										2 7/8 - 16 UN	3.160 (80.3)			
48											3 - 16 UN	3.220 (81.8)	3.220 (81.8)		
	48										3 1/16 - 16 UN	3.410 (86.6)			

* Code C, MIL-C-22992, Left-Hand Thread. Connector designations depicted thus [] are for reference only and are not to be used in part number development.

BACKSHELL INTERFACE STANDARDS (See pages 15-17 for more information)

DESIG. SPEC.	SERIES	DESIG. SPEC.	SERIES	DESIG. SPEC.	SERIES	DESIG. SPEC.	SERIES
A	MIL-DTL-5015 MS3400	A	PATT 602	G	MIL-C-28840	L	EN3372
	MIL-DTL-26482 2	B	MIL-DTL-5015 MS3100	H	MIL-DTL-38999 III & IV		JN 1003
	AS81703 3	C	MIL-C-22992 MS173XX		EN3645		LN 29729
	MIL-DTL-83723 I & III	D	MIL-DTL-26482 1	J	MIL-C-81511 1, 2, 3 & 4		NFC93422
	40M39569	E	MIL-DTL-26500 Aluminum	K	VG95329		PAN 6433-2
	DEF 5326-3	F	MIL-DTL-38999 I & II				PATT 615
	EN 2997, 3646		40M38277				VG 96912
	ESC 10, 11		PAN 6433-1			S	PATT 105
	LN 29504		PATT 614				PATT 603
	NFC93422 HE302		PATT 616				PATT 608
	PAN 6432-1, -2		NFC93422 HE308, 9				



Reference Information Standard Materials and Finishes

TABLE II - STANDARD FINISHES

GLENAIR SYMBOL	M85049 SYMBOL REFERENCE ONLY	FINISH	SPECIFICATION(S)
A		Cadmium Plate, Bright	AMS-QQ-P-416, Type I, Class 2
B		Cadmium Plate, Olive Drab	AMS-QQ-P-416, Type II, Class 3
C*	A	Anodize, Black	AMS-A-8625, Type II, Class 2
G*		Hard Coat, Anodic	AMS-A-8625, Type III, Class 1
J		Iridite, Gold Over Cadmium Plate Over Electroless Nickel	MIL-C-5541, Class 3 AMS-QQ-P-416, Type II, Class 3 over AMS-C-26074, Class 4, Grade B
LF		Cadmium Plate, Bright Over Electroless Nickel	1000 Hour Corrosion Resistance
M	N	Electroless Nickel	AMS-C-26074, Class 4, Grade B
N		Cadmium Plate, Olive Drab Over Electroless Nickel	AMS-QQ-P-416, Type II, Class 3 over Electroless Nickel AMS-C-26074
NC		Zinc Cobalt, Dark Olive Drab	96 Hour Corrosion Resistance
NF	W	Cadmium Plate, Olive Drab Over Electroless Nickel	1000 Hour Corrosion Resistance
T		Cadmium Plate, Bright Over Electroless Nickel	AMS-QQ-P-416, Type I, Class 3 ASTMB 733-90, SC2, Type I, Class 5, MIL-C-26074***
U		Cadmium Plate, Black	AMS-QQ-P-416, Type II, Class 3
ZU**		Cadmium Plate, Black	AMS-QQ-P-416, Type II, Class 3
ZN		Zinc-Nickel Alloy, Olive Drab	ASTMB 841-91, Over Electroless Nickel 1000 Hour Salt Spray

* Anodize finish; not suitable for EMI Shielding or grounding applications.
** Applicable to corrosion resisting steel backshells and accessories. Consult factory for other available finishes.

The following standard materials are used for the majority of Glenair backshells and connector accessories. However, backshell components are not limited to those items listed, but are representative of

the elements used in Glenair's general accessory products. Contact Glenair for applicable specifications on items not listed below.

STANDARD MATERIALS - BACKSHELLS AND ACCESSORIES

COMPONENT	MATERIAL	SPECIFICATION
Machined components: such as backshell bodies, fabricated elbows, protective covers, rotatable couplers, dummy stowage receptacles, lock nuts, G-spring support rings, EMI ground rings, grommet followers, etc.	Aluminum	AMS-QQ-A-200 ASTMB221, 209
Die cast components: such as angular backshells, strain relief backshells, strain relief bodies, strain relief saddles, special EMI ground rings, etc.	Aluminum	QQ-A-591 ASTMB85, 26
Backshells or strain reliefs: available in optional corrosion resisting steel; and hardware: such as screws, washers, rivets, wire rope, sash chain, band straps, etc.	Corrosion Resisting Steel	ASTMA582 (300 Series) AMS-QQ-S-763
Elastomeric seals: such as O-rings, cable jacket seals, grommets, etc.	Silicone	A-A-59588
	Fluorosilicone	MIL-DTL-25988
Anti-friction and thrust washers	Fluoropolymer	TFE
Anti-rotation device	Corrosion Resistant Material	N/A

BODY STRAP

Glenair offers an optional stainless steel body strap for attaching protective covers as illustrated. To specify body strap, add suffix letter C to the end of the part number. For example 360AS001M1610M6C.



2-56 Screw and Nut

NOTES

On all length callouts, tolerance is $\pm .060$ unless otherwise specified.

Unless otherwise specified, the following other dimensional tolerances will apply:

- .xx = $\pm .03$ (0.8)
- .xxx = $\pm .015$ (0.4)
- Lengths = $\pm .060$ (1.52)
- Angles = $\pm 5^\circ$

Metric dimensions (mm) are indicated in parentheses

NOTE: For your convenience these tables have been reproduced inside the back cover fold-out.

Glenair Backshell and Accessory Material and Finish Options

Backshell and accessory base materials, plating options, specifications and codes

Code	Material	Finish	Finish Specification
A	Aluminum	Cadmium, No Chromate	SAE-AMS-QQ-P-416 Type I Class 3
AB	Marine Bronze	Unplated	
AL	Aluminum	AlumiPlate, Clear Chromate	MIL-DTL-83488, Class 2, Type II over electroless nickel
B	Aluminum	Cadmium, Olive Drab	SAE-AMS-QQ-P-416 Type II Class 3
C	Aluminum	Anodize, Black	AMS-A-8625 Type II Class 2
E	Aluminum	Chem Film	MIL-DTL-5541 Type 1 Class 3
G	Aluminum	Anodize, Hardcoat	AMS-A-8625 Type III, Class 1, .001" thick
J	Aluminum	Cadmium, Gold	SAE-AMS-QQ-P-416 Type II, Class 2 over electroless nickel
JF	Aluminum	Cadmium, Gold	SAE-AMS-QQ-P-416 Type II, Class 2 over electroless nickel
LF	Aluminum	Cadmium, Clear	SAE-AMS-QQ-P-416 Type II Class 2 over electroless nickel
M	Aluminum	Electroless Nickel	AMS-C-26074 Class 4 Grade B; ASTM-B-733, SC 2, Type IV
MT	Aluminum	Nickel-PTFE	AMS2454
N	Aluminum	Cadmium, Olive Drab	SAE-AMS-QQ-P-416 Type II Class 3 over electroless nickel
NC	Aluminum	Zinc-Cobalt, Olive Drab	ASTM B 840 Grade 6 Type D over electroless nickel
NF	Aluminum	Cadmium, Olive Drab	SAE-AMS-QQ-P-416 Type II Class 2 over electroless nickel
P	Stainless Steel	Electrodeposited Nickel	SAE-AMS-QQ-N-290 Class 1 Grade F
T	Aluminum	Cadmium, No Chromate	SAE-AMS-QQ-P-416 Type I Class 3
TP2	Titanium	Electrodeposited Nickel	SAE-AMS-QQ-N-290 Class 1 Grade F
U	Aluminum	Cadmium, Black	SAE-AMS-QQ-P-416 Type I Class 3
UC	Aluminum	Zinc-Cobalt, Black	ASTM B 840 Grade 6 Type D over electroless nickel
UCR	Aluminum	Zinc-Cobalt, Black	ASTM B 840 Grade 6 Type D over electroless nickel
UF	Aluminum	Cadmium, Black	SAE-AMS-QQ-P-416 Type II Class 2 over electroless nickel
XAL	Composite	AlumiPlate	MIL-DTL-86448, Class 2, Type II over electroless nickel
XB	Composite	Unplated Black	
XM	Composite	Electroless Nickel	AMS-C-26074
XMT	Composite	Nickel-PTFE	GMS-002 Class 2 Type II
XO	Composite	Unplated Light Brown	
XW	Composite	Cadmium, Olive Drab	SAE-AMS-QQ-P-416 Type II Class 3 over electroless nickel
XZN	Composite	Zinc-Nickel, Black	ASTM B841 Grade 5 over electroless nickel
Z1	Stainless Steel	Passivate	SAE-AMS-SAE-AMS-QQ-P-35 Type VI
Z2	Aluminum	Gold	MIL-DTL-45204 Class 1 over electroless nickel
ZC	Stainless Steel	Zinc-Cobalt, Black	ASTM-B840, Grade 6
ZCR	Stainless Steel	Zinc-Cobalt, Black	ASTM-B840, Grade 6
ZL	Stainless Steel	Electrodeposited Nickel	SAE-AMS-QQ-N-290 Class 1 Grade F
ZM	Stainless Steel	Electroless Nickel	AMS-C-26074 Class 1 Grade A
ZMT	Stainless Steel	Nickel-PTFE	GMF-002 Type II Class 3
ZN	Aluminum	Zinc-Nickel, Olive Drab	ASTM B841 Grade 5 over electroless nickel
ZNU	Aluminum	Zinc-Nickel, Black	ASTM B841 Grade 5 over electroless nickel
ZR	Aluminum	Zinc-Nickel, Black	ASTM B841 Grade 5 over electroless nickel
ZU	Stainless Steel	Cadmium, Black	SAE-AMS-QQ-P-416 Type II Class 3
ZW	Stainless Steel	Cadmium, Olive Drab	SAE-AMS-QQ-P-416 Type II Class 2 over electroless nickel



Connector Designator "B" Ordering Information MIL-DTL-5015 Connector Fittings (MS3100 Series)

How to Order Backshells for Mil-DTL-5015 (MS3100 Series) Connectors

The threads and interface dimensions on MIL-DTL-5015 solder-type connectors are unfortunately not standardized from one manufacturer to the next. As a result, there is limited interchangeability in many shell sizes and service classes amongst available MS3100 Series products. When ordering backshells for 5015 connectors it is therefore necessary to treat each connector manufacturer's product separately to ensure optimum compatibility of the backshell-to-connector interface. This is accomplished in two steps: (1) Use the connector designator "B" in the normal place in the part number to indicate to the factory that a MIL-DTL-5015 (MS3100 Series) connector is being used; and (2) Use an additional connector manufacturer symbol, as shown in the part number development example below, to indicate whose MIL-DTL-5015 product you are using. Connector manufacturer symbols for 5015 products are shown in the table below and pertinent connector fitting interface information is given on page 19.

Please Note: For proper use of Glenair backshells with MS3100 Series connectors, discard all rear hardware, including wire seal grommets, normally supplied with the connector. (This information does not apply to endbell extenders commonly supplied with MS3100A Series connectors.)

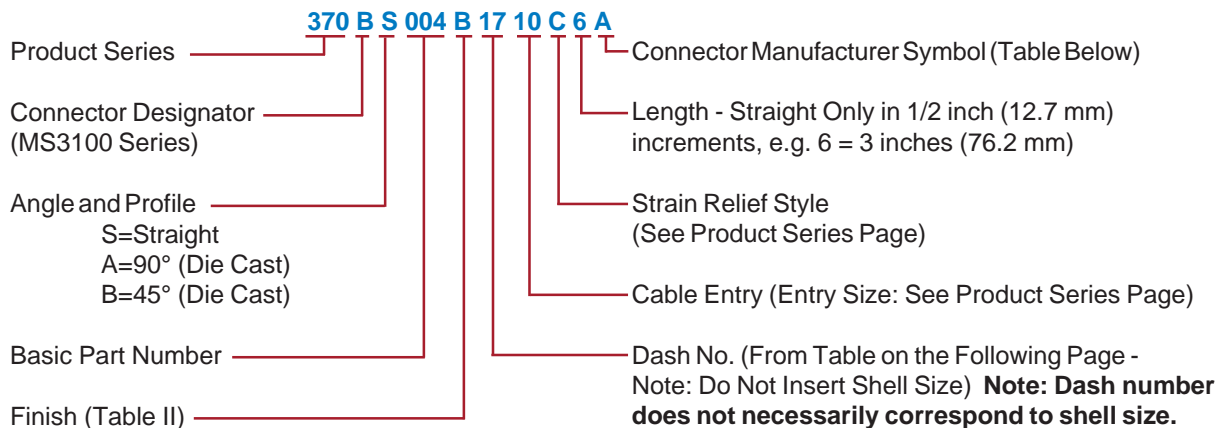

MIL-C-5015 CONNECTOR MANUFACTURER SYMBOLS			
SYMBOL	MANUFACTURER	CONNECTOR SERIES	CLASS
A	All	MS3100, 01, 06	A/E/F/R
H	Amphenol	MS3100, 01, 06 97 Series Blue Insert	A
J		MS3100, 01, 06	E/F/R
L	Amphenol/BCO	MS3100, 01, 06 10-214, 10-720 10-721, 10-726	A/E/F/R
M	Cannon	MS3100, 01, 06	A
N	Cannon	MS3100, 01, 063 CA00, 01, 06	E/F/R

Interface Dimensions MIL-DTL-5015 Connector Fittings (MS3100 Series)



How to Order

MS 3100 SERIES MANUFACTURER DESIGNATIONS						
DASH NO.	SHELL SIZE	CONN. MFG DESIG.	SEE NOTE 1	A THREAD CLASS 2B	B DIA MAX	C DIA NOM
01	8S	A	1	7/16 - 28 UNEF	.656 (16.7)	.625 (15.9)
02	8S	J, M, N,	2	7/16 - 28 UNEF	.656 (16.7)	.625 (15.9)
03	8S	L	3	3/8 - 32 UNEF	.607 (15.4)	.562 (14.3)
04	8S	H	3	7/16 - 27 UNS	.656 (16.7)	.625 (15.9)
05	10S	A	1	1/2 - 28 UNEF	.724 (18.4)	.687 (17.4)
06	10S	H, J, L, N	2	1/2 - 28 UNEF	.724 (18.4)	.687 (17.4)
07	10S	M	3	9/16 - 24 UNEF	.724 (18.4)	.687 (17.4)
08	10SL	A	1	9/16 - 24 UNEF	.724 (18.4)	.687 (17.4)
09	10SL	M, N	2	9/16 - 24 UNEF	.724 (18.4)	.687 (17.4)
10	10SL	H, J, L	3	5/8 - 24 UNEF	.848 (21.5)	.812 (20.6)
11	12, 12S	A	1	5/8 - 24 UNEF	.848 (21.5)	.812 (20.6)
12	12, 12S	L, N	2	5/8 - 24 UNEF	.848 (21.5)	.812 (20.6)
13	12, 12S	H, J, M	3	11/16 - 24 UNEF	.848 (21.5)	.812 (20.6)
14	12SL, 14, 14S	A	2	3/4 - 20 UNEF	.974 (24.7)	.937 (23.8)
15	16, 16S	A	2	7/8 - 20 UNEF	1.102 (28.0)	1.062 (27.0)
16	18	A	2	1 - 20 UNEF	1.220 (31.0)	1.187 (30.1)
17	20	A	1	1 1/8 - 18 UNEF	1.343 (34.1)	1.312 (33.3)
18	20	H,L,M,N	2	1 1/8 - 18 UNEF	1.343 (34.1)	1.312 (33.3)
19	20	J	3	1 1/8 - 24 UNS	1.343 (34.1)	1.312 (33.3)
20	22	A	2	1 1/4 - 18 UNEF	1.468 (37.3)	1.437 (36.5)
21	24	A	2	1 3/8 - 18 UNEF	1.593 (40.5)	1.562 (39.7)
22	28	A	2	1 5/8 - 18 UNEF	1.843 (46.8)	1.812 (46.0)
23	32	A	1	1 7/8 - 16 UN	2.125 (54.0)	2.062 (52.4)
24	32	L, M, N	2	1 7/8 - 16 UN	2.125 (54.0)	2.062 (52.4)
25	32	H, J	3	1 29/32 - 18 UNS	2.125 (54.0)	2.062 (52.4)
26	36	A	1	2 1/8 - 16 UN	2.375 (60.3)	2.312 (58.7)
27	36	M, N	2	2 1/8 - 16 UN	2.375 (60.3)	2.312 (58.7)
28	36	L	3	2 1/16 - 16 UNS	2.375 (60.3)	2.312 (58.7)
29	36	J	3	2 1/16 - 20 UNEF	2.375 (60.3)	1.312 (33.3)
30	36	H	3	2 1/8 - 18 UNS	2.375 (60.3)	2.312 (58.7)
31	40	A	1	2 3/8 - 16 UN	2.625 (66.7)	2.562 (65.1)
32	40	H, M, N	2	2 3/8 - 16 UN	2.625 (66.7)	2.562 (65.1)
33	40	L	3	2 5/16 - 16 UNS	2.625 (66.7)	2.562 (65.1)
34	44	A	2	2 5/8 - 16 UN	2.906 (73.8)	2.875 (73.0)
35	48	A	1	2 7/8 - 16 UN	3.156 (80.2)	3.125 (79.4)
36	48	H	2	2 7/8 - 16 UN	3.156 (80.2)	3.125 (79.4)
37	48	N	3	2 13/16 - 18 UNS	3.156 (80.2)	3.125 (79.4)

1. If the specific manufacturer is not known, order symbol A and corresponding dash number, for MS universal fit.
2. Symbol A mates with all connectors for each shell size.
3. Additional transition adapters may be supplied with symbol A for each shell size, as noted.

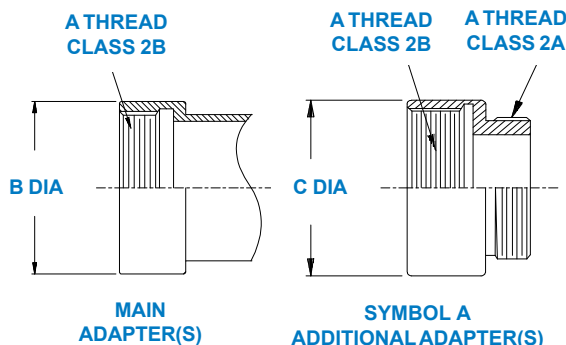

X-ON Electronics

Largest Supplier of Electrical and Electronic Components

Click to view similar products for [Circular MIL Spec Backshells](#) category:

Click to view products by [Glenair](#) manufacturer:

Other Similar products are found below :

[5M2919-3DW](#) [5M2920-3CW](#) [5M2953-1HW](#) [60-036152-022](#) [610HS012M15](#) [M28840/504WA](#) [M28840/805WB](#) [M28840/809WA](#)
[M28840/815WA](#) [M28840/816WA](#) [627AS017M14](#) [62GB5851608S](#) [655HS002NF11](#) [CW3703-000](#) [CW3899-000](#) [M85049/10-134S](#)
[M85049/10-17S](#) [M85049/10-33S](#) [M85049/10-94W](#) [M85049/11-09W](#) [M85049/11-28N](#) [M85049/11-37N](#) [M85049/11-53N](#) [M85049/11-63N](#)
[M85049/118-20W](#) [M85049/124-23W](#) [M85049/124S09W](#) [M85049/126S23W](#) [M850491712W02](#) [M85049/1720N04B](#) [M85049/1817N06](#)
[M850491819W03](#) [M85049/1821W05C](#) [M85049/1825W06C](#) [M85049/1919N05](#) [M85049/1919W04](#) [M850491919W07](#) [M85049/23-59W](#)
[M85049/23-74W](#) [M8504924-5W](#) [M85049/24-71N](#) [M85049/25-47N](#) [M85049/25-94W](#) [M85049/27S12N](#) [M8504938-13S](#) [M85049/38-19S](#)
[M85049/39-11S](#) [M85049/39-17S](#) [M85049/39-9S](#) [M85049/3W4A2](#)