

General Description

The AOZ6135 is a high performance single-pole double-throw (SPDT), low power, TTL-compatible bus switch.

The AOZ6135 can handle analog and digital signals. Signals with voltages up to V_{CC} (1.65V to 5.5V) can be transmitted in either direction.

When the Select pin is LOW, B_0 is connected to the output A pin. When the Select pin is HIGH, B_1 is connected to the output A pin. The path that is open will have a high-impedance state with respect to the output. Break-before-make is guaranteed.

Features

- SC-70 6-Lead Package
- 1.65V to 5.5V V_{CC} operation
- 1Ω connection between ports
- Break-before-make switching



Typical Application

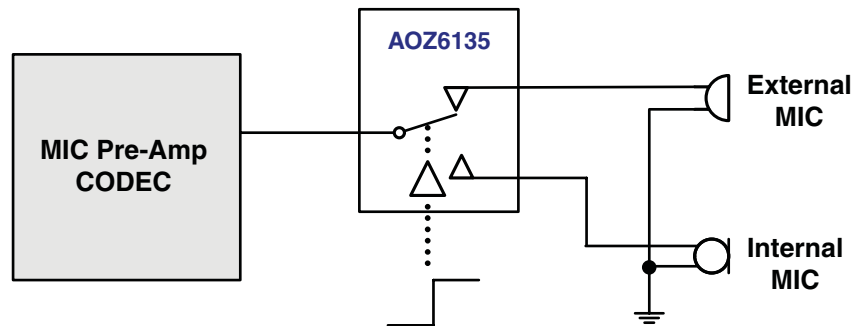

Ordering Information

Part Number	Ambient Temperature Range	Package	Environmental
AOZ6135HI	-40°C to +85°C	SC-70-6	RoHS Compliant Green Product



AOS Green Products use reduced levels of Halogens, and are also RoHS compliant.
Please visit www.aosmd.com/web/quality/rohs_compliant.jsp for additional information.

Pin Configuration

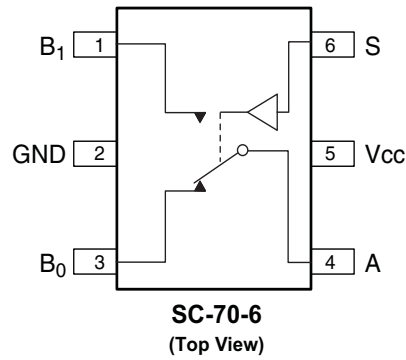

Truth Table

Logic S Input	Function
0	B ₀ Connected to A
1	B ₁ Connected to A

Absolute Maximum Ratings

Exceeding the Absolute Maximum ratings may damage the device.

Symbol	Parameter	Rating
V _{CC}	Supply Voltage	-0.5V to +6V
V _S	Switch Voltage ⁽¹⁾	-0.5V to V _{CC}
V _{IN}	Input Voltage ⁽¹⁾	-0.5V to V _{CC}
I _{IK}	Minimum Input Diode Current ⁽²⁾	-50mA
I _{SW}	Switch Current	200mA
I _{SWPEAK}	Peak Switch Current (Pulsed at 1ms, <10% Duty Cycle)	400mA
T _{STG}	Storage Temperature Range	-65°C to +150°C
T _J	Maximum Junction Temperature	+150°C
P _D	SC-70-6 Power Dissipation at 85°C ⁽³⁾	180mW
ESD	Human Body Model (JESD22A-114E)	8000V

Recommend Operating Ratings

The device is not guaranteed to operate beyond the Maximum Operating Ratings.

Symbol	Parameter	Rating
V _{CC}	Supply Voltage	1.65V to +5.5V
V _{IN}	Control Input Voltage ⁽⁴⁾	0V to V _{CC}
V _{SW}	Switch Input Voltage	0V to V _{CC}
T _A	Operating Temperature	-40°C to +85°C

Notes:

1. Signals on A, or B or S exceeding V+ will be clamped by internal diodes. Limit forward diode current to maximum current ratings.
2. Negative current should not exceed minimum negative value.
3. All leads welded or soldered to PC Board.
4. Unused inputs must be held HIGH or LOW. They may not float.

Electrical Characteristics

Unless otherwise indicated, specifications indicate a temperature range of -40°C to +85°C

Symbol	Parameter	Test Conditions	V _{CC} (V)	Min.	Typ. ⁽¹⁾	Max.	Units
DC CHARACTERISTICS							
V _{IH}	Input Voltage High		1.65 to 2.7	1.0			V
			2.7 to 3.6	1.5			
			4.5 to 5.5	2.0			
V _{IL}	Input Voltage Low		1.65 to 2.7			0.4	V
			2.7 to 3.6			0.6	
			4.5 to 5.5			0.8	
R _{ON}	On Resistance	I _{OUT} = 100mA, B0 or B1 = 0V, 1.5V, 2.5V, 3.5V, 3.75V, 4.5V	4.5		0.6	1.2	Ω
		I _{OUT} = 100mA, B0 or B1 = 0V, 1.5V, 2V, 2.7V	2.7		1.0	1.5	
		I _{OUT} = 100mA, B0 or B1 = 0V, 1.25V, 1.5V, 1.8V	1.8		3.0	6.0	
R _{FLAT}	On Resistance Flatness	I _{OUT} = 100mA, B0 or B1 = 0V to V _{CC}	4.5		0.2		Ω
			2.7		0.3		
			1.8		2.5		
ΔR _{ON}	On Resistance Matching Between Channels	I _{OUT} = 100mA, B0 or B1 = 1.5V	4.5		0.03	0.15	Ω
		I _{OUT} = 100mA, B0 or B1 = 3.5V					
I _{IN}	Input Leakage Current	V _{IN} = 0V or V _{CC}	1.95 to 5.5			±1.0	μA
I _{B(off)}	Off Stage Switch Leakage	A = 1V, 4.5V, B0 or B1 = 4.5V, 1V	1.95 to 5.5			±20	nA
I _{A(on)}	On State Switch Leakage	A = 1V, 4.5V, B0 or B1 = 4.5V, 1V or floating	1.95 to 5.5			±40	nA
POWER SUPPLY							
V _{CC}	Power Supply Range		1.65 to 5.5	1.65		5.5	V
I _{CCQ}	Quiescent Supply Current	V _{IN} = 0V or V _{CC} , I _{OUT} = 0V	5.5			0.5	μA
I _{CCT}	Increase in I _{CC} per Input	V _{IN} = 1.8V	5.5		30	40	μA
		V _{IN} = 2.6V			18	25	

Electrical Characteristics (Continued)

Unless otherwise indicated, specifications indicate a temperature range of -40°C to +85°C

Symbol	Parameter	Test Conditions	V _{CC} (V)	Min.	Typ. ⁽¹⁾	Max.	Units
AC CHARACTERISTICS							
t _{ON}	Turn-On Time	B ₀ or B ₁ = 1.5V, R _L = 50Ω, C _L = 35pF	2.7 to 3.6			60 65	ns
			4.5 to 5.5			35 40	
t _{OFF}	Turn-Off Time	B ₀ or B ₁ = 1.5V, R _L = 50Ω, C _L = 35pF	2.7 to 3.6			20 30	ns
			4.5 to 5.5			15 20	
t _{BBM}	Break-Before-Make Time		1.65 to 1.95		20		ns
			2.3 to 2.7		20		
			3.0 to 3.65		20		
			4.5 to 5.5		20		
Q	Charge Injection	C _L = 1.0nF, V _{GE} = 0V, R _{GEN} = 0Ω	4.5 to 5.5		75		pC
			2.7 to 3.6		50		
ANALOG SWITCH CHARACTERISTICS							
OIRR	Off Isolation	R _L = 50Ω, f = 1MHz	2.7 to 5.5		-60		dB
X _{TALK}	Crosstalk	R _L = 50Ω, f = 1MHz	2.7 to 5.5		-60		dB
BW	-3dB Bandwidth	R _L = 50Ω	2.7 to 5.5		180		MHz
THD	Total Harmonic Distortion	V _{IN} = 2V _{pk-pk} , f = 20Hz to 20kHz	2.7 to 5.5		0.002		%
CAPACITANCE							
C _{IN}	Control Pin Capacitance	f = 1MHz, V _{bias} = 1.5V	0.0		3.0		pF
C _{OFF}	B Port Off Capacitance	f = 1MHz, V _{bias} = 1.5V	4.5		7.0		pF
C _{ON}	A Port Capacitance When Switch Enable	f = 1MHz, V _{bias} = 1.5V	4.5		40.0		pF

Notes:

1. Typical values are for design aid only, not guaranteed nor subject to production testing.

AC Loading and Waveforms

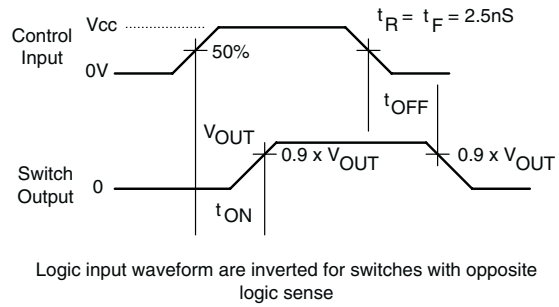
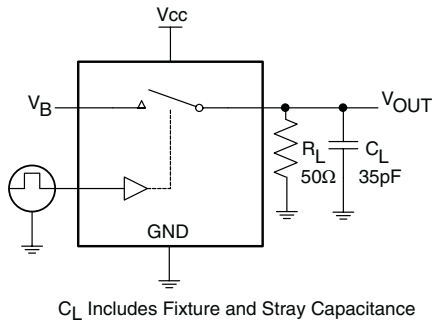

Figure 1. Turn-On/Turn-Off Timing

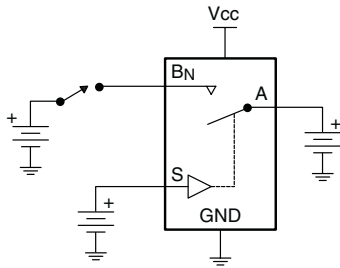

Figure 2. Off State Leakage Current

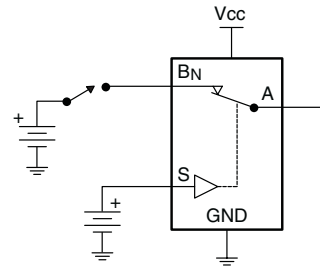

Figure 3. On State Leakage Current

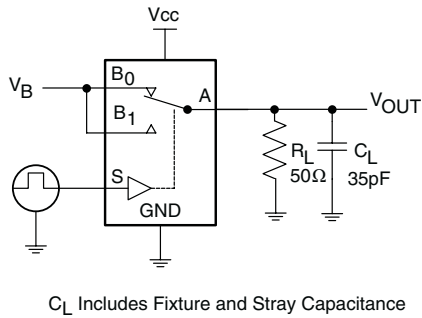

Figure 4. Break-Before-Make Timing

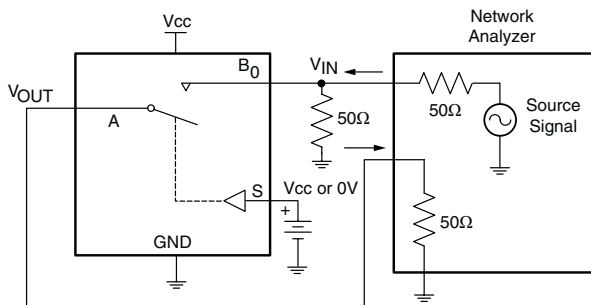
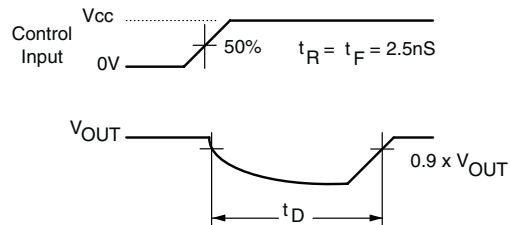

Figure 5. Off Isolation

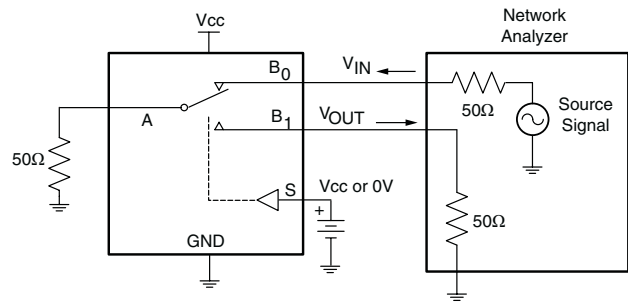

Figure 6. Crosstalk

AC Loading and Waveforms (Continued)

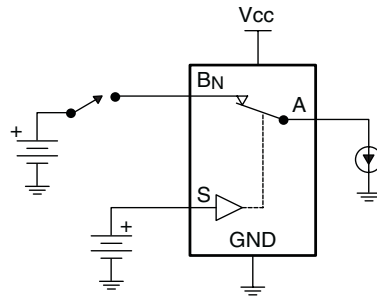

Figure 7. On State Resistance

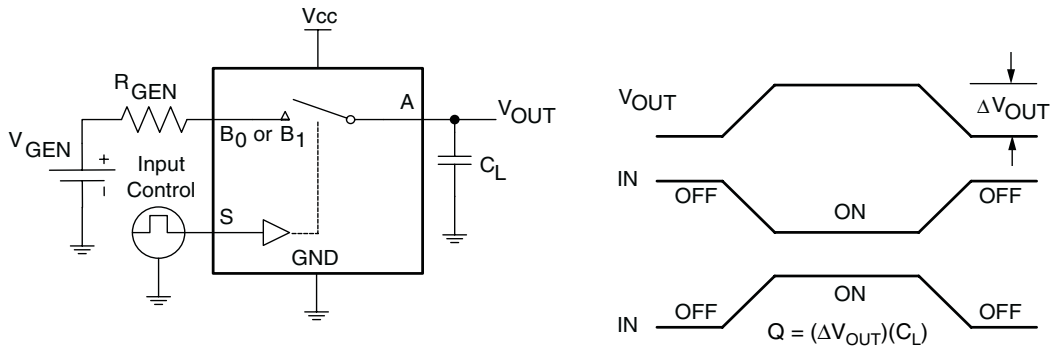

Figure 8. Charge Injection

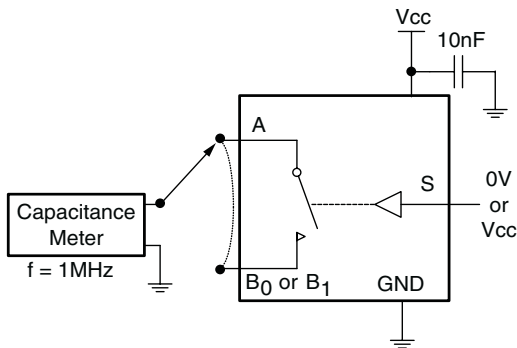

Figure 9. ON/Off Capacitance Measurement

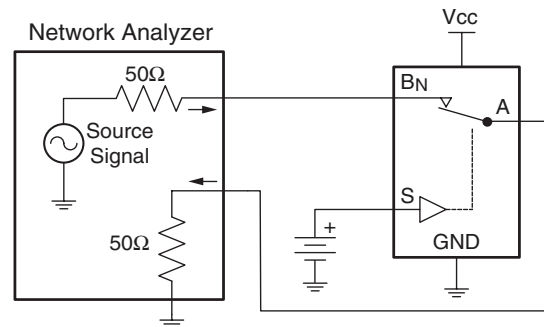
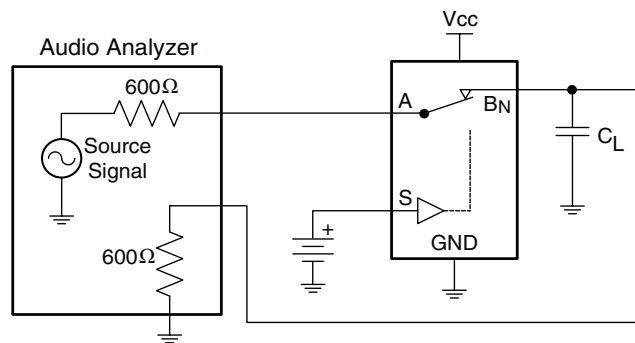

Figure 10. Bandwidth



C_L Includes Fixture and Stray Capacitance

Figure 11. Harmonic Distortion

Package Dimensions, SC70-6L

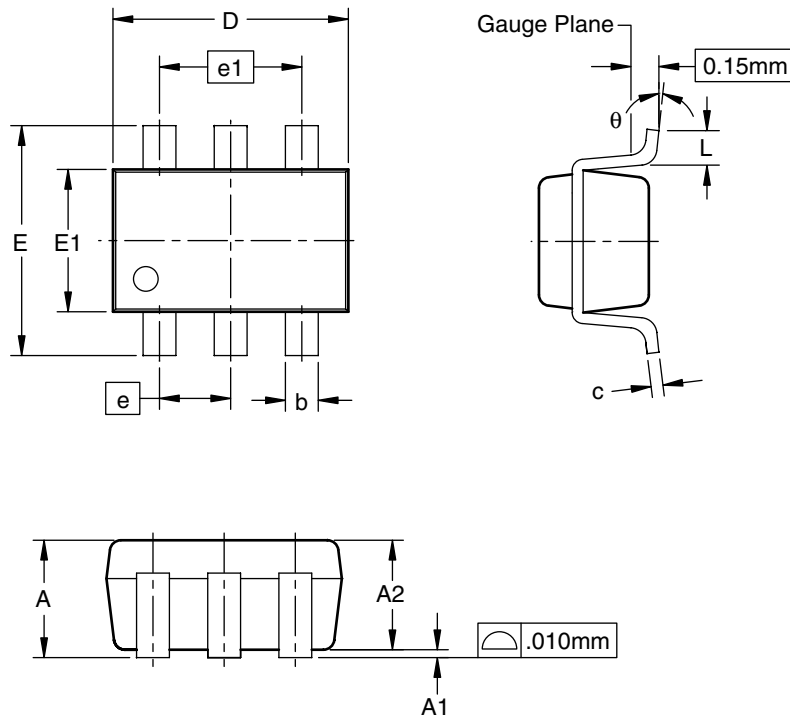

RECOMMENDED LAND PATTERN

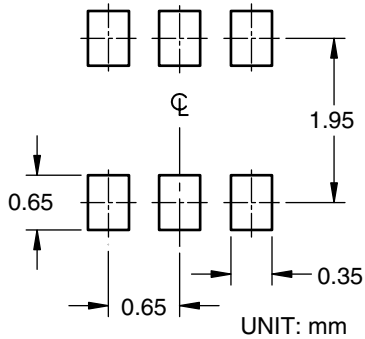

Dimensions in millimeters

Symbols	Min.	Nom.	Max.
A		—	1.10
A1	0.00	—	0.10
A2	0.7	0.9	1.00
b	0.15	—	0.30
c	0.08	—	0.22
D	1.85	2.10	2.15
E	1.80	2.30	2.40
e	0.65 BSC		
e1	1.30 BSC		
E1	1.1	1.30	1.4
L	0.26	0.36	0.46
θ	0°	4°	8°

Dimensions in inches

Symbols	Min.	Nom.	Max.
A		—	0.043
A1	0.00	—	0.004
A2	0.028	0.035	0.039
b	0.006	—	0.012
c	0.003	—	0.009
D	0.073	0.083	0.085
E	0.071	0.091	0.094
e	0.026 BSC		
e1	0.051 BSC		
E1	0.043	0.051	0.055
L	0.010	0.014	0.018
θ	0°	4°	8°

Notes:

1. All dimensions are in millimeters.
2. Dimensions are inclusive of plating
3. Package body sizes exclude mold flash and gate burrs. Mold flash at the non-lead sides should be less than 3 mils.
4. Die is facing up for mold and facing down for trim/form; i.e., reverse trim/form.
5. Dimension L is measured in gauge plane.
6. Controlling dimension is millimeter, converted inch dimensions are not necessarily exact.

Tape and Reel Dimensions, SC70-6L

Carrier Tape

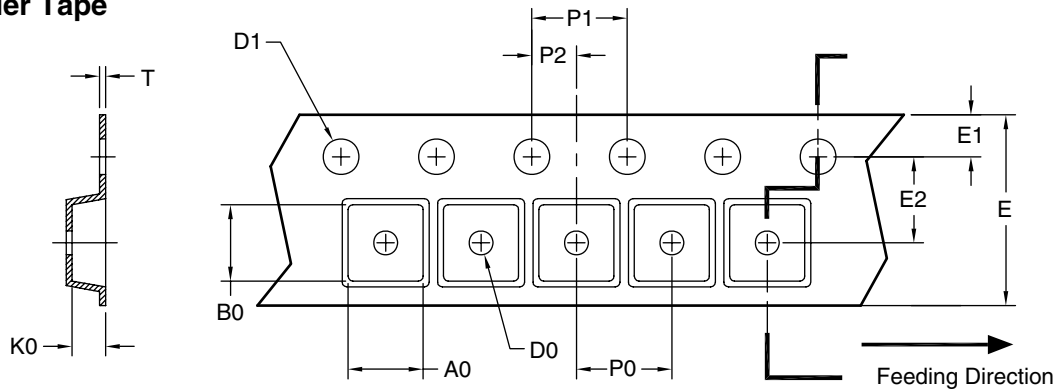

UNIT: mm

Package	A0	B0	K0	D0	D1	E	E1	E2	P0	P1	P2	T
SC-70, 6L (8mm)	2.40 ±0.10	2.40 ±0.10	1.19 ±0.10	1.00 Min.	1.55 ±0.05	8.00 ±0.30	1.75 ±0.10	3.50 ±0.05	4.00 ±0.10	4.00 ±0.10	2.00 ±0.05	0.25 ±0.05

Reel

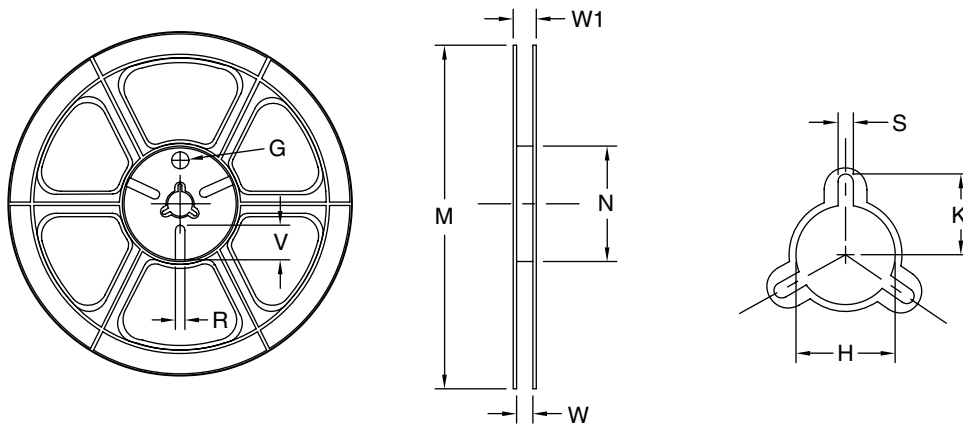

Tape Size	Reel Size	M	N	W	W1	H	K	S	G	R	V
8mm	ø180	ø180.00 ±0.50	ø60.50	9.00 ±0.30	11.40 ±1.00	ø13.00 +0.50/-0.20	10.60	2.00 ±0.50	ø9.00	5.00	18.00

Leader/Trailer and Orientation

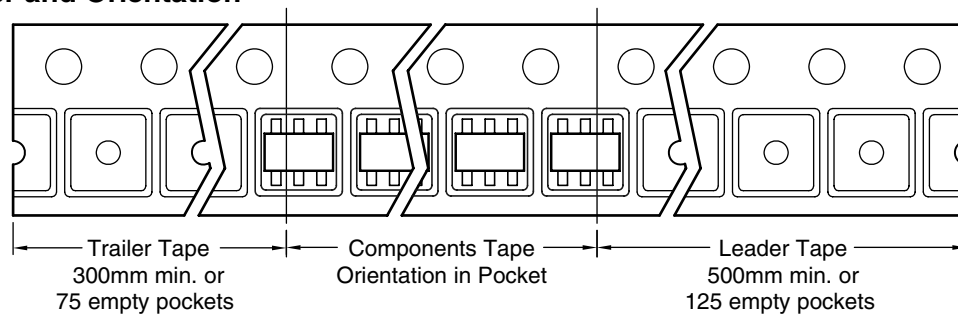

Part Marking

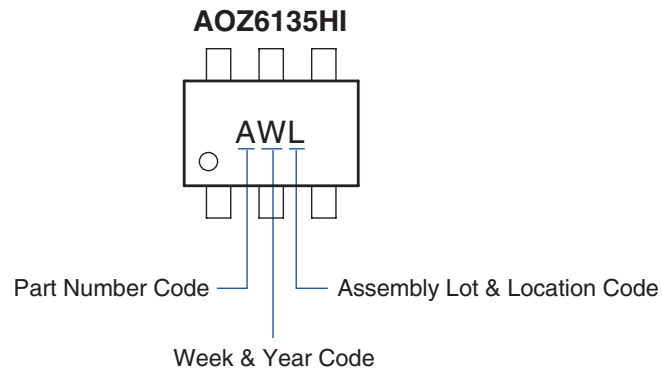

Revision History

Revision	Revised Item
Rev. 1.0	Initial release
Rev. 1.1	IccT Max Limit relaxed after production data were collected

This datasheet contains preliminary data; supplementary data may be published at a later date. Alpha & Omega Semiconductor reserves the right to make changes at any time without notice.

LIFE SUPPORT POLICY

ALPHA & OMEGA SEMICONDUCTOR PRODUCTS ARE NOT AUTHORIZED FOR USE AS CRITICAL COMPONENTS IN LIFE SUPPORT DEVICES OR SYSTEMS.

As used herein:

1. Life support devices or systems are devices or systems which, (a) are intended for surgical implant into the body or (b) support or sustain life, and (c) whose failure to perform when properly used in accordance with instructions for use provided in the labeling, can be reasonably expected to result in a significant injury of the user.
2. A critical component in any component of a life support, device, or system whose failure to perform can be reasonably expected to cause the failure of the life support device or system, or to affect its safety or effectiveness.

X-ON Electronics

Largest Supplier of Electrical and Electronic Components

Click to view similar products for [Analogue Switch ICs category](#):

Click to view products by [Alpha & Omega manufacturer](#):

Other Similar products are found below :

[FSA3051TMX](#) [NLVAS4599DTT1G](#) [MAX4992EVB+T](#) [MAX4684ETB+T](#) [BCM6522IPBG](#) [BCM65300IFSBG](#) [MAX14764ETA+T](#)
[TMUX1113RSVR](#) [TMUX1112RSVR](#) [ADG1436TRUZ-EP](#) [BL4684C](#) [PE423422A](#) [PE42359SCAA](#) [PE42540F](#) [RS550YUCM12](#)
[ADGS1414DBCCZ](#) [ADG658YRUZ-REEL7](#) [RS2117YUTQK10](#) [RS2118YUTQK10](#) [RS2227XUTQK10](#) [SP2526A-1EN-L/TR](#) [FSA4157P6X](#)
[BA7603F-E2](#) [MAX4702EUE+](#) [MAX4617CUE+](#) [MAX4599EUT+T](#) [MAX4066ESD+](#) [MAX4052ACSE+](#) [MAX396CAI+](#) [MAX391CPE+](#)
[MAX4730EXT+T](#) [MAX314CPE+](#) [MAX4051AEEE+](#) [BU4066BCFV-E2](#) [MAX313CPE+](#) [BU4S66G2-TR](#) [TS3A4751PWR](#)
[NCN1154MUTAG](#) [DG444DY-E3](#) [NLAS4157DFT2G](#) [NLAS4599DFT2G](#) [NLAS7242MUTBG](#) [NLASB3157DFT2G](#) [NLAST4599DFT2G](#)
[NLAST4599DTT1G](#) [DG403DY-T1-E3](#) [MAX4714EXTT](#) [MAX392CPE](#) [BGSX22G2A10E6327XTSA1](#) [ADG1611BRUZ-REEL7](#)