

DO NOT
SCALE FROM
THIS PRINT

MEC1-1XX-XX-XX-D-RAX-XX-SL-XX

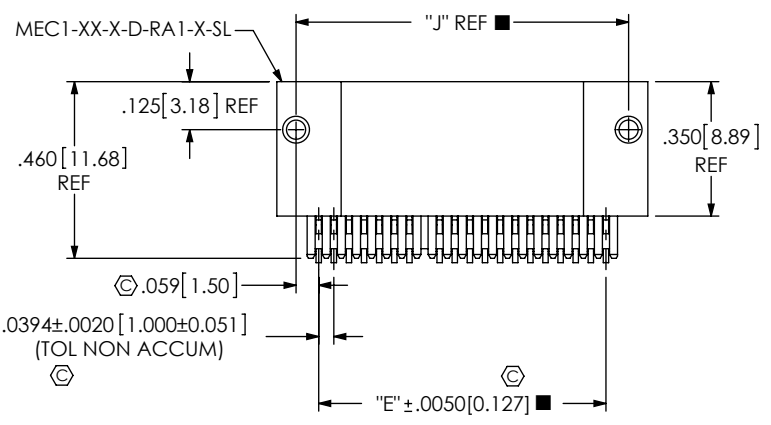
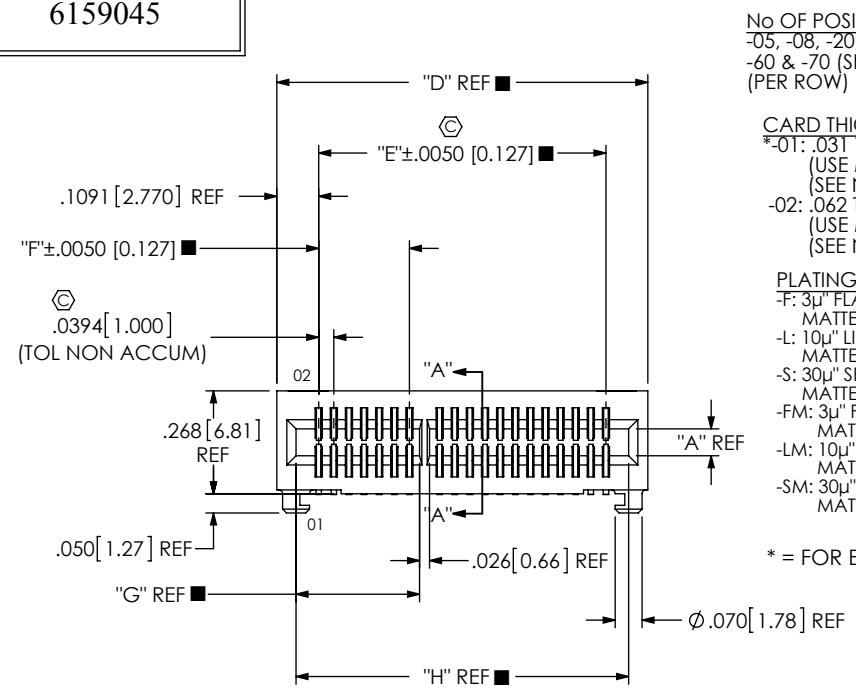

FIG 1
MEC1-120-02-XX-D-RA1-SL SHOWN
■ = SEE TABLE 3, SHT 2

No OF POSITIONS
-05, -08, -20, -30, -40, -50 (SEE FIG 1)
-60 & -70 (SEE FIG 2, SHT 3)
(PER ROW)

CARD THICKNESS
*-01: .031 THICK CARD
(USE MEC1-XX-T-D-RAX-X-SL)
(SEE NOTE 9)
-02: .062 THICK CARD
(USE MEC1-XX-S-D-RAX-X-SL)
(SEE NOTE 9)

PLATING
-F: 3µ" FLASH GOLD IN CONTACT AREA,
MATTE TIN ON TAIL
-L: 10µ" LIGHT GOLD IN CONTACT AREA,
MATTE TIN ON TAIL
-S: 30µ" SELECTIVE GOLD IN CONTACT AREA,
MATTE TIN ON TAIL
-FM: 3µ" FLASH GOLD IN CONTACT AREA,
MATTE ON TIN TAIL
-LM: 10µ" LIGHT IN CONTACT AREA,
MATTE TIN ON TAIL
-SM: 30µ" SELECTIVE GOLD IN CONTACT AREA,
MATTE TIN ON TAIL

* = FOR EXISTING CUSTOMERS ONLY

OPTION
-TR: TAPE & REEL
(SUBSTITUTE -T: FOR -TR:
DESIGNATION WHEN USING -XM
PLATING DESIGNATION WITH
BOTH -NP AND -SL OPTIONS)
(-T OR -TR OPTION NOT AVAILABLE
FOR 70 POS)

SOLDER LOCKS

NON-POLARIZED OPTION
-NP: NO POLARIZED POSITION
(ONLY AVAILABLE ON -05,
-08, -20, & -30 POSITIONS)
(SEE FIG 4, SHT 3)
-BLANK: BODY IS POLARIZED

TAIL OPTION
-RA1: STANDARD
-RA2: ELEVATED (SEE FIG 3, SHT 3)

ROW SPECIFICATION
-D: DOUBLE (USE MEC1-XX-X-D-RAX-X-SL)

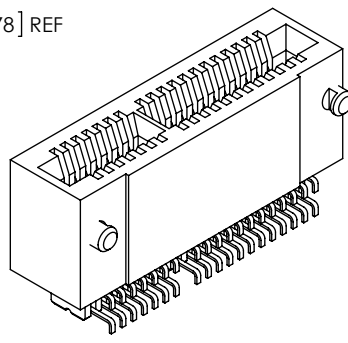

TABLE 1

CARD	"A"	"B"	"C"
*-01	.0400 [1.016]	.0161 [0.409]	.008 [0.20]
-02	.0700 [1.778]	.0298 [0.757]	.010 [0.25]

* = FOR EXISTING CUSTOMERS ONLY

TABLE 2

POSITION	COPLANARITY	STRAIGHTNESS
-05, -08, -20, -30, -40	.0040[0.102]	.004[0.10]
-50, -60, -70	.0060[0.152]	.006[0.15]

NOTES:

1. Ⓢ REPRESENTS A CRITICAL DIMENSION.
2. MAXIMUM BURR ALLOWANCE: .004[0.10].
3. MINIMUM PUSHOUT FORCE: .5 LB.
4. TAIL OPTION -RA1 TO HAVE C-150-01-XX-X CONTACT FULLY PRE-FORMED.
5. BODIES TO BE LAYER PACKAGED FOR TRANSIT BETWEEN INVENTORY AND PRODUCTION.
6. TO BE MEASURED AT 2 MAIN 90° BENDS.
7. MEASURE FIRST AND LAST PIN OF EACH ROW.
8. FOR QUANTITIES UP TO 49 PIECES, NO LEADER, TRAILER, OR REEL WILL BE SUPPLIED.
FOR QUANTITIES OF 50-124 PIECES, NO LEADER OR TRAILER WILL BE SUPPLIED.
9. MATING EDGE CARD THICKNESS TOLERANCE TO BE ±10% OF NOMINAL FOR -01; ±7.5% FOR -02.

UNLESS OTHERWISE SPECIFIED,
DIMENSIONS ARE IN INCHES.
TOLERANCES ARE:
DECIMALS ANGLES
.XX: ±.01 [0.3] 2°
.XXX: ±.005 [0.13]
.XXXX: ±.0020 [0.051]

PROPRIETARY NOTE
THIS DOCUMENT CONTAINS INFORMATION
CONFIDENTIAL AND PROPRIETARY TO
SAMTEC, INC. AND SHALL NOT BE REPRODUCED
OR TRANSFERRED TO OTHER DOCUMENTS OR
DISCLOSED TO OTHERS OR USED FOR ANY
PURPOSE OTHER THAN THAT WHICH IT WAS
OBTAINED WITHOUT THE EXPRESSED WRITTEN
CONSENT OF SAMTEC, INC.



520 PARK EAST BLVD, NEW ALBANY, IN 47150
PHONE: 812-944-6733 FAX: 812-948-5047
e-Mail: info@SAMTEC.com code: 55322

MATERIAL: DO NOT SCALE DRAWING SHEET SCALE: 2:1
FLAMMABILITY RATING: UL 94V-0
INSULATOR: LCP
-01: COLOR: NATURAL
-02: COLOR: BLACK
CONTACT: PHOS BRONZE

DESCRIPTION: 1mm MEC1 -RA ASSEMBLY
DWG. NO. MEC1-1XX-XX-XX-D-RAX-XX-SL-XX
BY: MARKS 01/25/00 SHEET 1 OF 5

TABLE 3

No OF POSITIONS	POLARIZED POSITIONS	"D"	"E"	"F"	"G"	"H"	"J"
-05	3 & 4	.3756 [9.540]	.1575 [4.000]	N/A	.0854 [2.169]	.275 [6.99]	.2756 [7.000]
-08	5 & 6	.4937 [12.540]	.2756 [7.000]	.0394 [1.001]	.1248 [3.170]	.394 [10.01]	.3937 [10.000]
-20	15 & 16	.9661 [24.540]	.7480 [19.000]	.2362 [5.999]	.3216 [8.169]	.866 [22.00]	.8661 [22.000]
-30	21 & 22	1.3598 [34.540]	1.1417 [29.000]	.3543 [8.999]	.4398 [11.171]	1.260 [32.00]	1.2598 [32.000]
-40	31 & 32	1.7535 [44.540]	1.5354 [39.000]	.5512 [14.000]	.6366 [16.170]	1.654 [42.01]	1.6535 [42.000]
-50	41 & 42	2.1472 [54.540]	1.9291 [49.000]	.7480 [18.999]	.8334 [21.168]	2.047 [51.99]	2.0472 [52.000]
-60	31 & 32, 63 & 64	2.5409 [64.540]	2.3228 [59.000]	.5512 [14.000]	.6366 [16.170]	2.441 [62.00]	2.4409 [62.000]
-70	53 & 54, 115 & 116	2.9346 [74.540]	2.7165 [69.000]	.9843 [25.001]	1.0696 [27.168]	2.835 [72.01]	2.8346 [71.999]

TABLE 4

CARD THICKNESS	TAIL OPTION	BOTTOM ROW	TOP ROW
*-01	-RA1	C-150-11-X-P	C-150-14-X-P
*-01	-RA2	C-150-15-X-P	C-150-16-X-P
-02	-RA1	C-150-01-X-P	C-150-04-X-P
-02	-RA2	C-150-05-X-P	C-150-06-X-P

* = FOR EXISTING CUSTOMERS ONLY

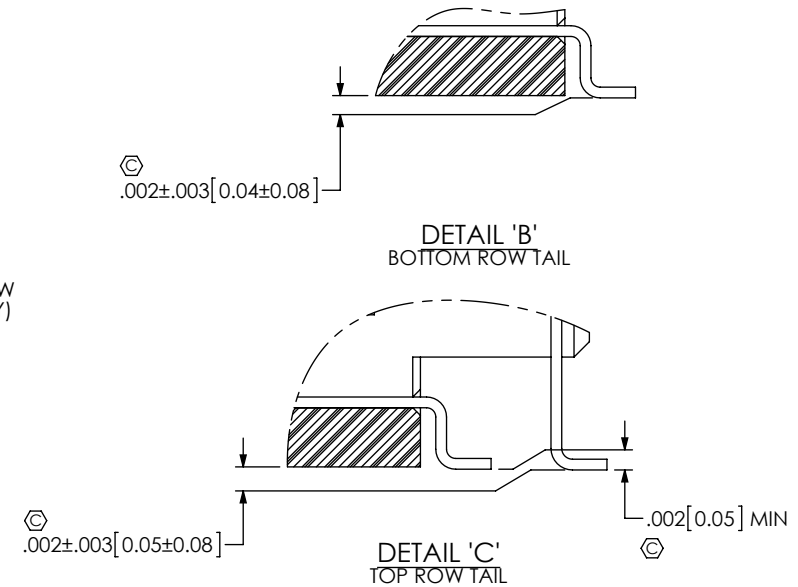
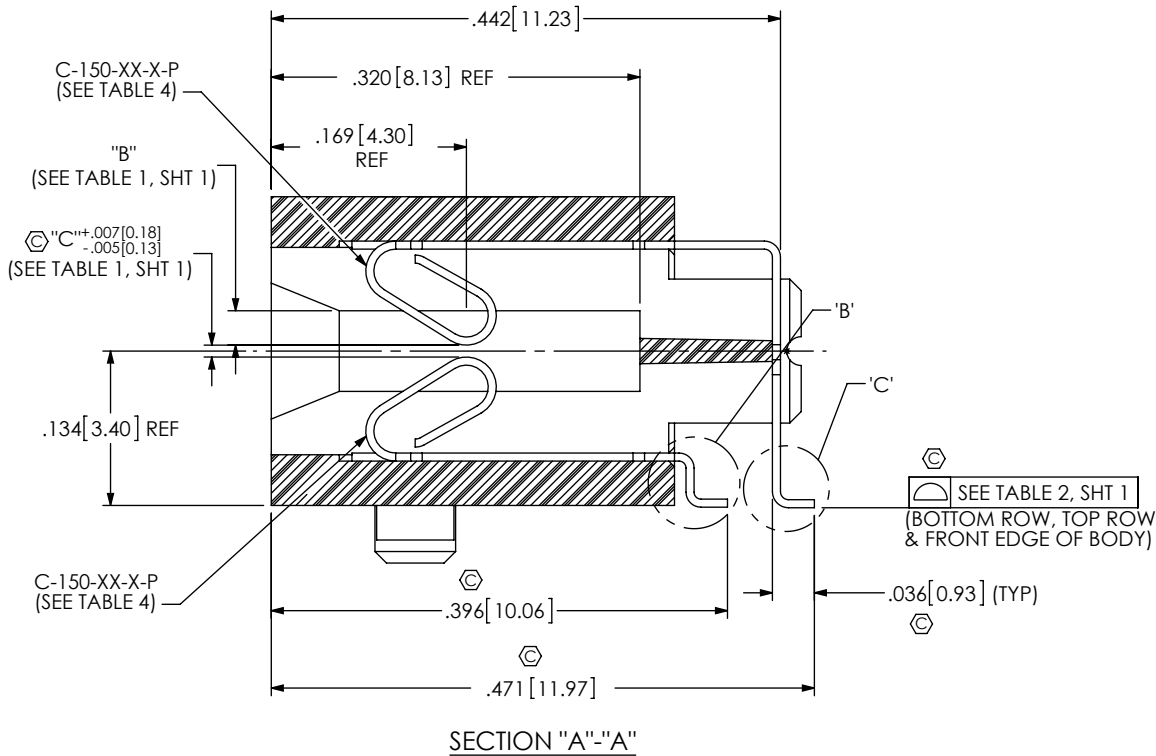

PROPRIETARY NOTE

THIS DOCUMENT CONTAINS INFORMATION CONFIDENTIAL AND PROPRIETARY TO SAMTEC, INC. AND SHALL NOT BE REPRODUCED OR TRANSFERRED TO OTHER DOCUMENTS OR DISCLOSED TO OTHERS OR USED FOR ANY PURPOSE OTHER THAN THAT WHICH IT WAS OBTAINED WITHOUT THE EXPRESSED WRITTEN CONSENT OF SAMTEC, INC.

DO NOT SCALE DRAWING

SHEET SCALE: 2:1



520 PARK EAST BLVD, NEW ALBANY, IN 47150
 PHONE: 812-944-6733 FAX: 812-948-5047
 e-Mail: info@SAMTEC.com code: 55322

DESCRIPTION:
 1mm MEC1 -RA ASSEMBLY

DWG. NO.
 MEC1-1XX-XX-XX-D-RAX-XX-SL-XX

BY: MARKS 01/25/00 SHEET 2 OF 5

TABLE 5		
No OF POSITION	"K"	"L"
-60	.5512 [14.000]	.604 [15.34]
-70	1.1417 [28.999]	1.196 [30.37]

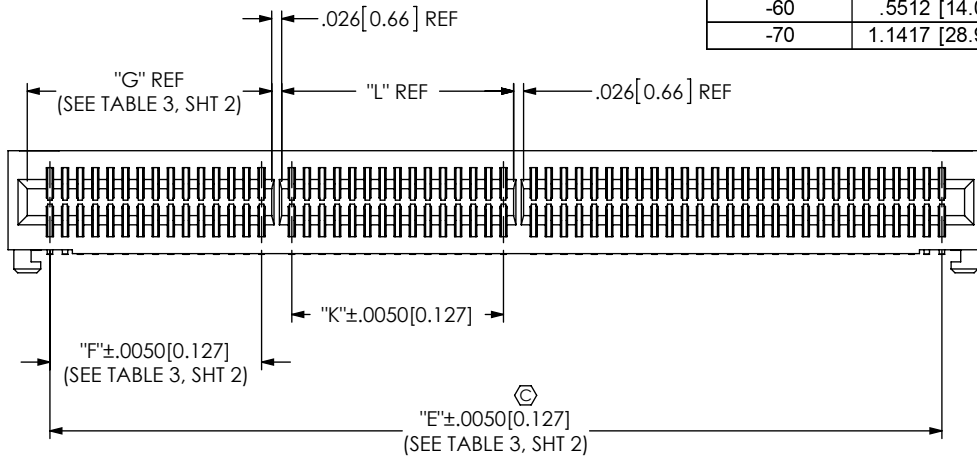

FIG 2
MEC1-160-02-XX-D-RA1-SL SHOWN
(-60 & -70 POSITION ONLY)
(DIFFERENT AS SHOWN, OTHERWISE SAME AS FIG 1)



FIG 4
MEC1-120-02-XX-D-RA1-NP-SL SHOWN
(DIFFERENT AS SHOWN, OTHERWISE SAME AS FIG 1)

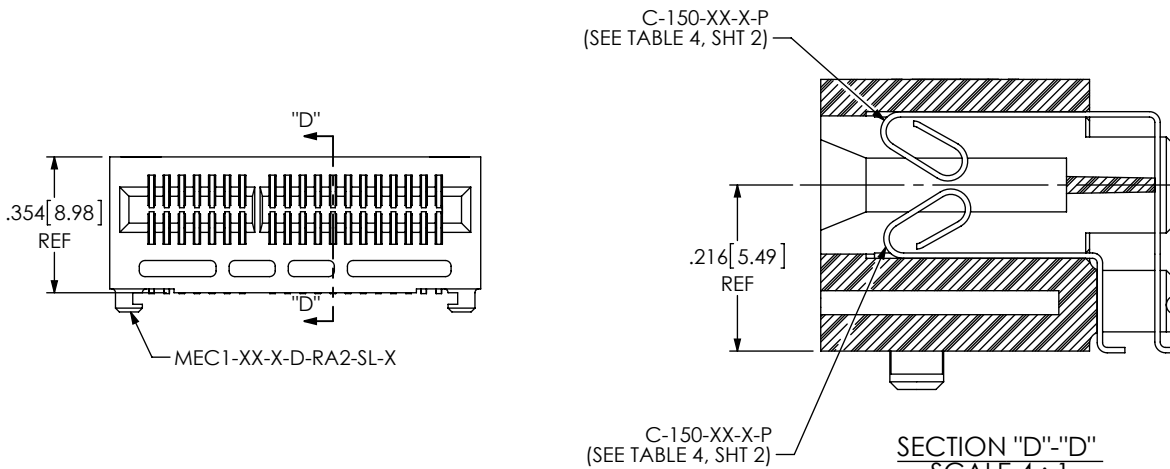
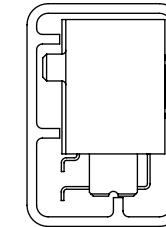

FIG 3
MEC1-120-02-XX-D-RA2-SL SHOWN
(DIFFERENT AS SHOWN, OTHERWISE SAME AS FIG 1)

PACKAGING VIEW

-RA1 TAIL OPTION

-RA2 TAIL OPTION



TUBE: PT-1-24-01-106
PLUG: TP-07

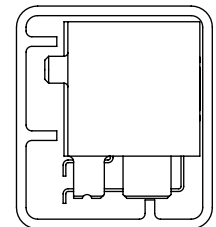

TUBE: PT-1-24-02-106
PLUG: TP-13

PROPRIETARY NOTE

THIS DOCUMENT CONTAINS INFORMATION CONFIDENTIAL AND PROPRIETARY TO SAMTEC, INC. AND SHALL NOT BE REPRODUCED OR TRANSFERRED TO OTHER DOCUMENTS OR DISCLOSED TO OTHERS OR USED FOR ANY PURPOSE OTHER THAN THAT WHICH IT WAS OBTAINED WITHOUT THE EXPRESSED WRITTEN CONSENT OF SAMTEC, INC.

DO NOT SCALE DRAWING

SHEET SCALE: 2:1



520 PARK EAST BLVD, NEW ALBANY, IN 47150
PHONE: 812-944-6733 FAX: 812-948-5047
e-Mail: info@SAMTEC.com code: 55322

DESCRIPTION:

1mm MEC1 -RA ASSEMBLY

DWG. NO.

MEC1-1XX-XX-XX-D-RAX-XX-SL-XX

BY: MARKS

01/25/00

SHEET 3 OF 5

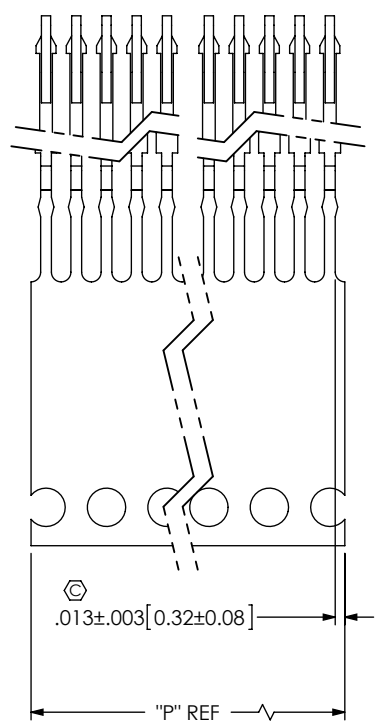
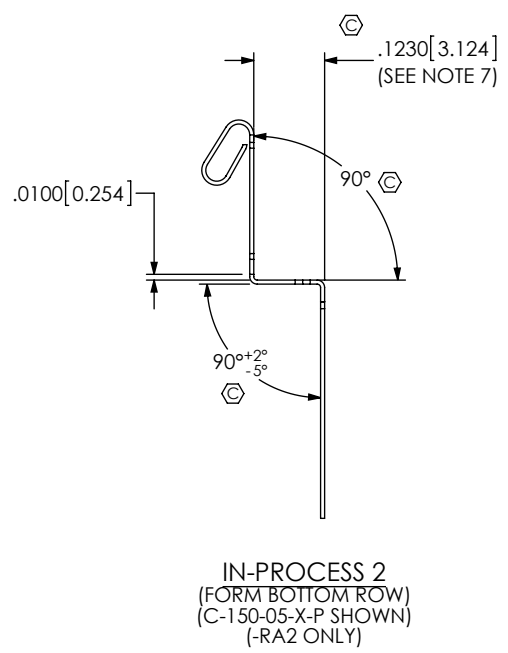

TABLE 6

No OF POSITIONS	"P"
-05	.197 [5.00]
-08	.315 [8.00]
-20	.787 [20.00]
-30	1.181 [30.00]
-40	1.575 [40.00]
-50	1.969 [50.00]
-60	2.362 [60.00]
-70	2.756 [70.00]

IN-PROCESS 1 & 5
(COMB CUT CONTACT)



IN-PROCESS 2
(FORM BOTTOM ROW)
(C-150-05-X-P SHOWN)
(-RA2 ONLY)

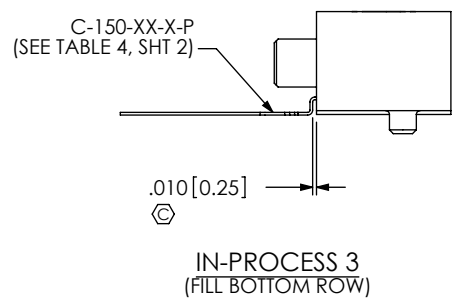

IN-PROCESS 3
(FILL BOTTOM ROW)

TABLE 7

TAIL OPTION	"N"	"M"
-RA1	.2295 [5.829]	.085 [2.16]
-RA2	.3140 [7.976]	.089 [2.26]

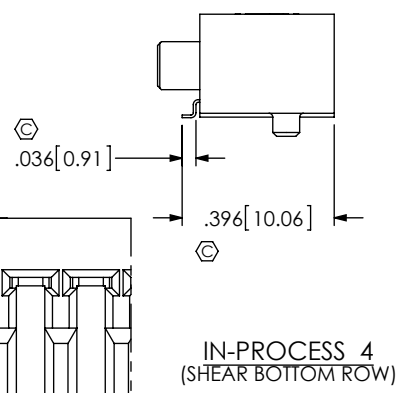
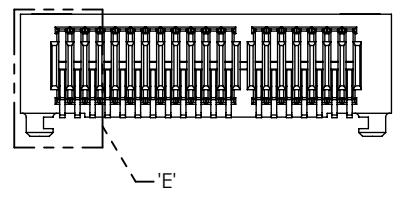

IN-PROCESS 4
(SHEAR BOTTOM ROW)

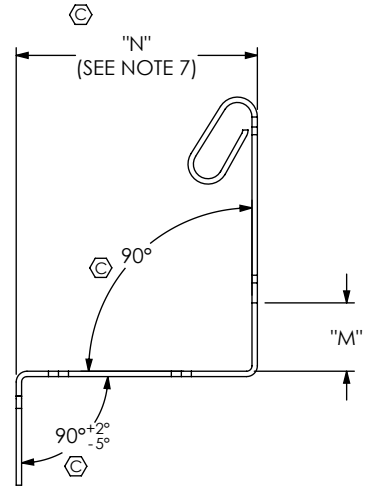

IN-PROCESS 6
(FORM TOP ROW)
(C-150-06-X-P SHOWN)

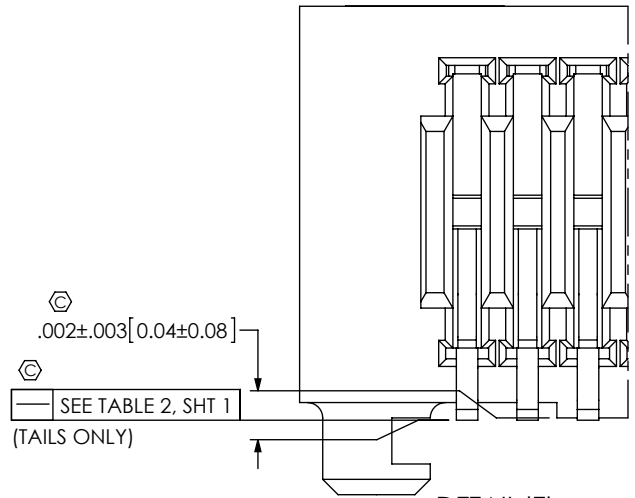

DETAIL 'E'
SCALE 8:1

PROPRIETARY NOTE
THIS DOCUMENT CONTAINS INFORMATION CONFIDENTIAL AND PROPRIETARY TO SAMTEC, INC. AND SHALL NOT BE REPRODUCED OR TRANSFERRED TO OTHER DOCUMENTS OR DISCLOSED TO OTHERS OR USED FOR ANY PURPOSE OTHER THAN THAT WHICH IT WAS OBTAINED WITHOUT THE EXPRESSED WRITTEN CONSENT OF SAMTEC, INC.

DO NOT SCALE DRAWING

SHEET SCALE: 4:1

samtec

520 PARK EAST BLVD. NEW ALBANY, IN 47150
PHONE: 812-944-6733 FAX: 812-948-5047
e-Mail: info@SAMTEC.com code: 55322

DESCRIPTION:
1mm MEC1 -RA ASSEMBLY

DWG. NO.
MEC1-1XX-XX-XX-D-RAX-XX-SL-XX

BY: MARKS 01/25/00 SHEET 4 OF 5

C-150-XX-X-P
(SEE TABLE 4, SHT 2)

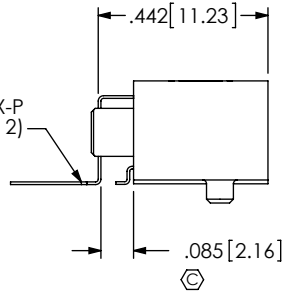

IN-PROCESS 7
(FILL TOP ROW)

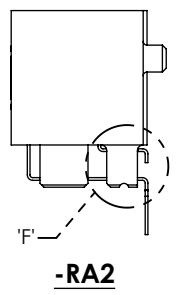

-RA2

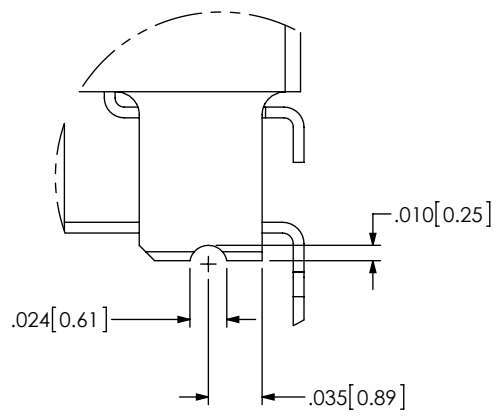

DETAIL 'F'
SCALE 8:1

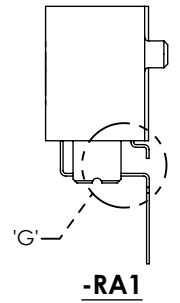

-RA1

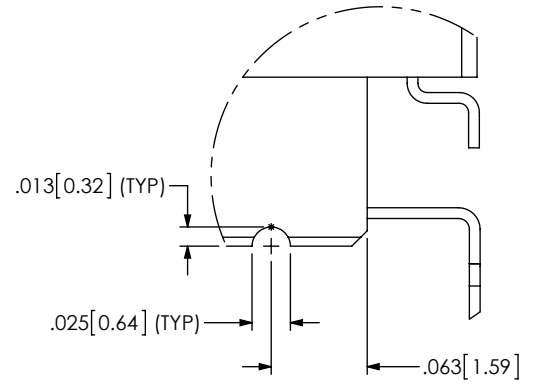

DETAIL 'G'
SCALE 8:1

IN PROCESS 8
HEAT STAKE TOP ROW

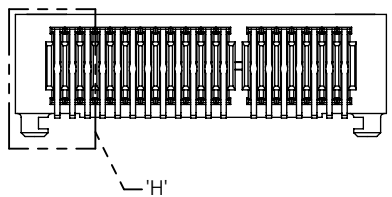

'H'

IN-PROCESS 9
(SHEAR TOP ROW)

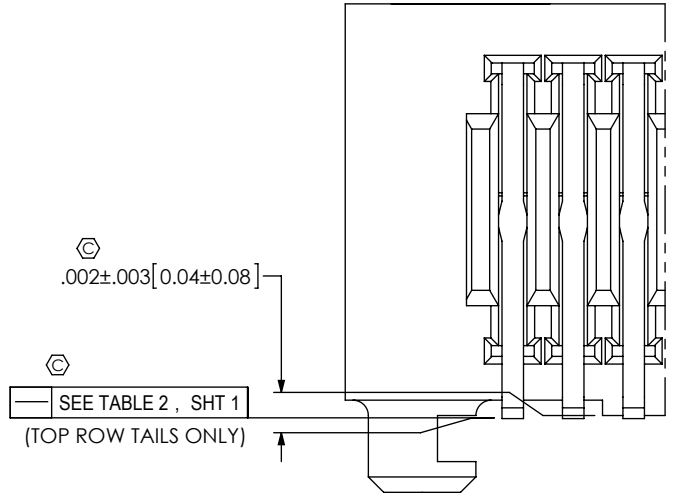
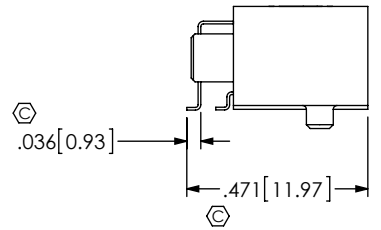

DETAIL 'H'
SCALE 8:1

PROPRIETARY NOTE
THIS DOCUMENT CONTAINS INFORMATION CONFIDENTIAL AND PROPRIETARY TO SAMTEC, INC. AND SHALL NOT BE REPRODUCED OR TRANSFERRED TO OTHER DOCUMENTS OR DISCLOSED TO OTHERS OR USED FOR ANY PURPOSE OTHER THAN THAT WHICH IT WAS OBTAINED WITHOUT THE EXPRESSED WRITTEN CONSENT OF SAMTEC, INC.

DO NOT SCALE DRAWING
SHEET SCALE: 2:1

samtec

520 PARK EAST BLVD. NEW ALBANY, IN 47150
PHONE: 812-944-6733 FAX: 812-948-5047
e-Mail: info@SAMTEC.com code: 55322

DESCRIPTION:
1mm MEC1 -RA ASSEMBLY

DWG. NO.
MEC1-1XX-XX-XX-D-RAX-XX-SL-XX

BY: MARKS 01/25/00 SHEET 5 OF 5

X-ON Electronics

Largest Supplier of Electrical and Electronic Components

Click to view similar products for [Standard Card Edge Connectors](#) category:

Click to view products by [Samtec](#) manufacturer:

Other Similar products are found below :

[6565204-6](#) [PKC-156](#) [1437274-4](#) [147889-1](#) [1489165-4](#) [EBT156-12B1X](#) [EBT15622B2X](#) [EBT156-22R2W](#) [1-582587-1](#) [1-582589-1](#) [2-6437275-9](#) [284-0102-12100](#) [306022901000000](#) [307-012-502-202](#) [307-024-526-201](#) [307-056-520-300](#) [307-080-526-208](#) [245-062-520-350](#) [287-0032-12101](#) [306-010-500-112](#) [306-028-525-102](#) [306-240-318](#) [307-036-502-202](#) [307-036-521-301](#) [307-072-526-202](#) [345-060-559-303](#) [368-004-520-201](#) [392-008-559-201](#) [534671-1](#) [5-530501-5](#) [341-240-317](#) [345-029-520-300](#) [345-030-500-301](#) [345-044-500-300](#) [345-220-058](#) [346-240-318](#) [357-030-526-201](#) [387-012-523-300](#) [395-044-520-300](#) [395-100-524-300](#) [50-12B-10](#) [50-6SN-5](#) [09-07-2032](#) [10035388-106LF](#) [10035388-802LF](#) [10122859-009LF](#) [10127905-B04B24BLF](#) [530555-1](#) [EBT156-15A2X](#) [2007209-1](#)