

FEATURES

- MANUFACTURED AT ISO/TS 16949 PRODUCTION FACILITY
- AEC-Q200 QUALIFIED
- SURFACE MOUNT CASE SIZES 0201, 0402, 0603, 0805, 1206, 1210 & 1812
- AVAILABLE IN NPO & X7R DIELECTRICS
- VOLTAGE RATINGS TO 1000VDC



SPECIFICATIONS

Type	NPO	X7R
Capacitance Range	0.1pF ~ 0.039μF	100pF ~ 10μF
Capacitance Tolerance	≤5.0pF: A (±0.05pF), B (±0.1pF), C (±0.25pF) >5.0pF<10pF: B (±0.1pF), C (±0.25pF), D (±0.5pF) ≥10pF: F (±1%), G (±2%), J (±5%)	J (±5%), ±10% (K), ±20% (M)
Operating Temperature Range	-55°C ~ +125°C	-55°C ~ +125°C
Temperature Characteristics	0±30 ppm/°C	±15%
Rated Voltages (VDC)	6.3V, 10V, 16V, 25V, 50V, 100V, 200V, 250V, 500V, 630V & 1000V	
Q Factor (Q) Dissipation Factor (DF)	Cap. ≥30pF: Q = 1,000 min. Cap. <30pF: Q = 400 +20xC (See Values & Specifications Tables)	DF Max. (See Values & Specifications Tables)
Insulation Resistance @ 25°C @ ≤ Rated Voltage for 60 Sec.	10,000MΩ or 500MΩ • μF Whichever is less	<100V 10,000MΩ or 500MΩ • μF whichever is less ≥100V 10,000MΩ or 100MΩ • μF whichever is less
Dielectric Withstanding Voltage	See Values & Specifications Tables	
Test Conditions	≤1000pF (1MHz±10%), 1.0Vrms ± 0.2Vrms >1000pF (1KHz ±10%), 1.0Vrms ± 0.2Vrms	1KHz, 1.0V ±0.2Vrms

Note: Reflow soldering allowed for all case sizes. Contact NIC for wave soldering restrictions.

PART NUMBER SYSTEM

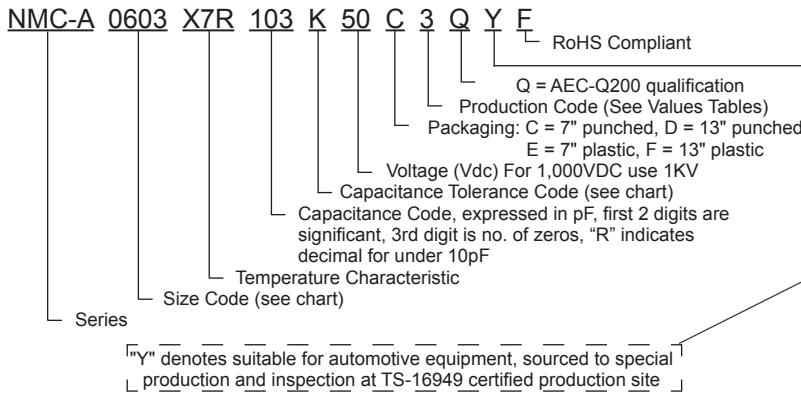

CASE SIZE DIMENSIONS (mm)

EIA Case Size	0201	0402	0603	0805	1206	1210	1812
Length (L)	0.60 ± 0.03	1.0 ± 0.05	1.6 +0.15/-0.10	2.0 ± 0.15	3.2+0.30/-0.10	3.2±0.40	4.5±0.40
Width (W)	0.30 ± 0.03	0.5 ± 0.05	0.8 +0.15/-0.10	1.25 ± 0.10	1.6+0.30/-0.10	2.5±0.30	2.5±0.25
Thickness max. (T)	See Part Number and Specifications Tables						
Termination Width (P)	0.10 ~ 0.20	0.15 ~ 0.30	0.25 ~ 0.65	0.30 ~ 0.70	0.40 ~ 0.80	0.50 ~ 1.00	0.25 ~ 0.75

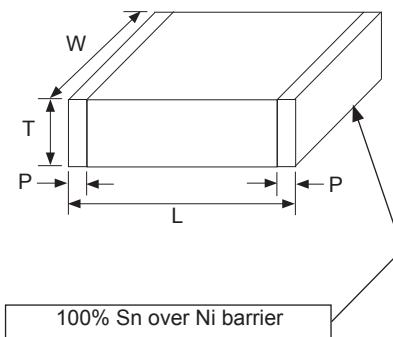

Automotive Electronics Council Component Technical Committee

AEC-Q200 - STRESS TEST QUALIFICATION FOR PASSIVE COMPONENTS

GRADE: 1

TEMPERATURE RANGE: -40°C ~ +125°C

PASSIVE COMPONENT TYPE: Capacitors, Ceramic Type (MLCCs)

ITEM	TEST	TEST CONDITIONS
1	Electrical Test	25°C
2	High Temperature Exposure	150°C, 1,000Hr
3	Temperature Cycling	Min temp. → 25°C → Max temp., 1,000 cycle
4	Destructive Physical Analysis	Electrical Test not required
5	Moisture Resistance	25~65°C, 90%RH, 10 cycle
6-1	Biased Humidity	85°C, 85%RH, Vr, 1,000Hr
6-2	Low Biased Humidity	85°C, 85%RH, 1.3~1.5V, 1,000Hr
7	High Temperature Operating Life	Max temp, Vr for 1,000Hr
8	External Visual	All qualification parts submitted
9	Physical Dimensions	Vernier Calipers
10	Mechanical Shock	1,500G, 15.4ft/s, Half Sine, Total 18 times
11	Vibration	10~2,000Hz, 5G's for 20min, Total 36 cycles
12	Resistance to Solder Heat	265°C, 10sec
14	Thermal Shock	Min temp (15min)→Max temp (15min), air to air, 300 cycle
14	ESD	22°C, 2KΩ, DC 0.5~8kV & AD 12~25kV
15-1	Solderability (Dry heat)	155°C, 4Hr → 245°C, 5 sec
15-2	Solderability (Steam aging)	93°C, 8Hr → 220°C, 10 sec
15-3	Solderability (Dewetting)	93°C, 8Hr → 260°C, 10 sec
16	Electrical Characterization	@25°C, 125°C
17	Board Flex	Deflection Point = 2mm (Class II), 3mm (Class I), 1mm/sec, 5 sec
18	Capacitance Temperature Characteristics	25 → -55 → 25 → 125°C
19	Terminal Strength (SMD)	0402 - 2N, 0603 - 10N, 0805 and larger - 18N, for 60±1 sec.
20	Beam Load	2.5mm/sec

NPO STANDARD VALUES AND SPECIFICATIONS

EIA Case Size		NPO 0201											
Length (L)		0.60 ± 0.03											
Width (W)		0.30 ± 0.03											
Termination Width(P)		0.15 ± 0.1											
Capacitance Value	Capacitance Code	Working Voltage (VDC)											
		10V			16V			25V			50V		
		DWV	Q	T max. (mm)	DWV	Q	T max. (mm)	DWV	Q	T max. (mm)	DWV	Q	T max. (mm)
0.1pF	0R1	25	402	0.33	40	402	0.33	62.5	402	0.33	125	402	0.33
0.2pF	0R2	25	404	0.33	40	404	0.33	62.5	404	0.33	125	404	0.33
0.3pF	0R3	25	406	0.33	40	406	0.33	62.5	406	0.33	125	406	0.33
0.4pF	0R4	25	408	0.33	40	408	0.33	62.5	408	0.33	125	408	0.33
0.5pF	0R5	25	410	0.33	40	410	0.33	62.5	410	0.33	125	410	0.33
0.6pF	0R6	25	412	0.33	40	412	0.33	62.5	412	0.33	125	412	0.33
0.7pF	0R7	25	414	0.33	40	414	0.33	62.5	414	0.33	125	414	0.33
0.8pF	0R8	25	416	0.33	40	416	0.33	62.5	416	0.33	125	416	0.33
0.9pF	0R9	25	418	0.33	40	418	0.33	62.5	418	0.33	125	418	0.33
1.0pF	1R0	25	420	0.33	40	420	0.33	62.5	420	0.33	125	420	0.33
1.2pF	1R2	25	424	0.33	40	424	0.33	62.5	424	0.33	125	424	0.33
1.5pF	1R5	25	430	0.33	40	430	0.33	62.5	430	0.33	125	430	0.33
1.8pF	1R8	25	436	0.33	40	436	0.33	62.5	436	0.33	125	436	0.33
2.2pF	2R2	25	444	0.33	40	444	0.33	62.5	444	0.33	125	444	0.33
2.7pF	2R7	25	454	0.33	40	454	0.33	62.5	454	0.33	125	454	0.33
3.3pF	3R3	25	466	0.33	40	466	0.33	62.5	466	0.33	125	466	0.33
3.9pF	3R9	25	478	0.33	40	478	0.33	62.5	478	0.33	125	478	0.33
4.7pF	4R7	25	494	0.33	40	494	0.33	62.5	494	0.33	125	494	0.33
5.6pF	5R6	25	512	0.33	40	512	0.33	62.5	512	0.33	125	512	0.33
6.8pF	6R8	25	536	0.33	40	536	0.33	62.5	536	0.33	125	536	0.33
8.2pF	8R2	25	564	0.33	40	564	0.33	62.5	564	0.33	125	564	0.33
10pF	100	25	600	0.33	40	600	0.33	62.5	600	0.33	125	600	0.33
12pF	120	25	640	0.33	40	640	0.33	62.5	640	0.33	125	640	0.33
15pF	150	25	700	0.33	40	700	0.33	62.5	700	0.33	125	700	0.33
18pF	180	25	760	0.33	40	760	0.33	62.5	760	0.33	125	760	0.33
22pF	220	25	840	0.33	40	840	0.33	62.5	840	0.33	125	840	0.33
27pF	270	25	940	0.33	40	940	0.33	62.5	940	0.33	125	940	0.33
33pF	330	25	1000	0.33	40	1000	0.33	62.5	1000	0.33	125	1000	0.33
39pF	390	25	1000	0.33	40	1000	0.33	62.5	1000	0.33	125	1000	0.33
47pF	470	25	1000	0.33	40	1000	0.33	62.5	1000	0.33	125	1000	0.33
56pF	560	25	1000	0.33	40	1000	0.33	62.5	1000	0.33	125	1000	0.33
68pF	680	25	1000	0.33	40	1000	0.33	62.5	1000	0.33	125	1000	0.33
82pF	820	25	1000	0.33	40	1000	0.33	62.5	1000	0.33	125	1000	0.33
100pF	101	25	1000	0.33	40	1000	0.33	62.5	1000	0.33	125	1000	0.33
120pF	121	25	1000	0.33	40	1000	0.33	62.5	1000	0.33	125	1000	0.33

(CONSULT FACTORY FOR CAPACITANCE VALUES NOT LISTED)

Specifications in BLACK = Production Code 3
 Specifications in BLUE = Production Code 4

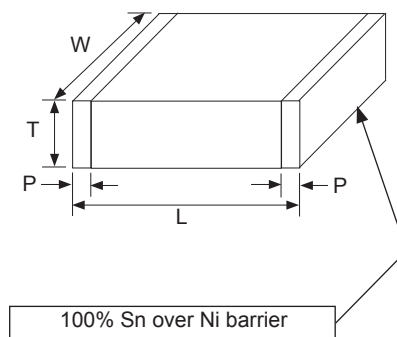

NPO STANDARD VALUES AND SPECIFICATIONS

EIA Case Size		NPO 0402											
Length (L)		1.00 ± 0.05											
Width (W)		0.50 ± 0.05											
Termination Width(P)		0.25 ± 0.1											
Capacitance Value	Capacitance Code	Working Voltage (VDC)											
		10V			16V			25V			50V		
		DWV	Q	T max. (mm)	DWV	Q	T max. (mm)	DWV	Q	T max. (mm)	DWV	Q	T max. (mm)
0.1pF	0R1	25	402	0.55	40	402	0.55	62.5	402	0.55	125	402	0.55
0.2pF	0R2	25	404	0.55	40	404	0.55	62.5	404	0.55	125	404	0.55
0.3pF	0R3	25	406	0.55	40	406	0.55	62.5	406	0.55	125	406	0.55
0.4pF	0R4	25	408	0.55	40	408	0.55	62.5	408	0.55	125	408	0.55
0.47pF	R47										125	409	0.55
0.5pF	0R5	25	410	0.55	40	410	0.55	62.5	410	0.55	125	410	0.55
0.56pF	R56										125	411	0.55
0.6pF	0R6	25	412	0.55	40	412	0.55	62.5	412	0.55	125	412	0.55
0.68pF	R68										125	414	0.55
0.7pF	0R7	25	414	0.55	40	414	0.55	62.5	414	0.55	125	414	0.55
0.8pF	0R8	25	416	0.55	40	416	0.55	62.5	416	0.55	125	416	0.55
0.82pF	R82										125	416	0.55
0.9pF	0R9	25	418	0.55	40	418	0.55	62.5	418	0.55	125	418	0.55
1.0pF	1R0	25	420	0.55	40	420	0.55	62.5	420	0.55	125	420	0.55
1.2pF	1R2	25	424	0.55	40	424	0.55	62.5	424	0.55	125	424	0.55
1.5pF	1R5	25	430	0.55	40	430	0.55	62.5	430	0.55	125	430	0.55
1.8pF	1R8	25	436	0.55	40	436	0.55	62.5	436	0.55	125	436	0.55
2.2pF	2R2	25	444	0.55	40	444	0.55	62.5	444	0.55	125	444	0.55
2.7pF	2R7	25	454	0.55	40	454	0.55	62.5	454	0.55	125	454	0.55
3.3pF	3R3	25	466	0.55	40	466	0.55	62.5	466	0.55	125	466	0.55
3.9pF	3R9	25	478	0.55	40	478	0.55	62.5	478	0.55	125	478	0.55
4.7pF	4R7	25	494	0.55	40	494	0.55	62.5	494	0.55	125	494	0.55
5.6pF	5R6	25	512	0.55	40	512	0.55	62.5	512	0.55	125	512	0.55
6.8pF	6R8	25	536	0.55	40	536	0.55	62.5	536	0.55	125	536	0.55
8.2pF	8R2	25	564	0.55	40	564	0.55	62.5	564	0.55	125	564	0.55
10pF	100	25	600	0.55	40	600	0.55	62.5	600	0.55	125	600	0.55
12pF	120	25	640	0.55	40	640	0.55	62.5	640	0.55	125	640	0.55
15pF	150	25	700	0.55	40	700	0.55	62.5	700	0.55	125	700	0.55
18pF	180	25	760	0.55	40	760	0.55	62.5	760	0.55	125	760	0.55
22pF	220	25	840	0.55	40	840	0.55	62.5	840	0.55	125	840	0.55
27pF	270	25	940	0.55	40	940	0.55	62.5	940	0.55	125	940	0.55
33pF	330	25	1000	0.55	40	1000	0.55	62.5	1000	0.55	125	1000	0.55
39pF	390	25	1000	0.55	40	1000	0.55	62.5	1000	0.55	125	1000	0.55
47pF	470	25	1000	0.55	40	1000	0.55	62.5	1000	0.55	125	1000	0.55
56pF	560	25	1000	0.55	40	1000	0.55	62.5	1000	0.55	125	1000	0.55
68pF	680	25	1000	0.55	40	1000	0.55	62.5	1000	0.55	125	1000	0.55
82pF	820	25	1000	0.55	40	1000	0.55	62.5	1000	0.55	125	1000	0.55
100pF	101	25	1000	0.55	40	1000	0.55	62.5	1000	0.55	125	1000	0.55
120pF	121	25	1000	0.55	40	1000	0.55	62.5	1000	0.55	125	1000	0.55
150pF	151	25	1000	0.55	40	1000	0.55	62.5	1000	0.55	125	1000	0.55
180pF	181	25	1000	0.55	40	1000	0.55	62.5	1000	0.55	125	1000	0.55
220pF	221	25	1000	0.55	40	1000	0.55	62.5	1000	0.55	125	1000	0.55
270pF	271	25	1000	0.55	40	1000	0.55	62.5	1000	0.55	125	1000	0.55
330pF	331	25	1000	0.55	40	1000	0.55	62.5	1000	0.55	125	1000	0.55
390pF	391	25	1000	0.55	40	1000	0.55	62.5	1000	0.55	125	1000	0.55
470pF	471	25	1000	0.55	40	1000	0.55	62.5	1000	0.55	125	1000	0.55
560pF	561	25	1000	0.55	40	1000	0.55	62.5	1000	0.55	125	1000	0.55
680pF	681	25	1000	0.55	40	1000	0.55	62.5	1000	0.55	125	1000	0.55
820pF	821	25	1000	0.55	40	1000	0.55	62.5	1000	0.55	125	1000	0.55
1,000pF	102	25	1000	0.55	40	1000	0.55	62.5	1000	0.55	125	1000	0.55

Specifications in BLACK = Production Code 3
 Specifications in BLUE = Production Code 4



NPO STANDARD VALUES AND SPECIFICATIONS

EIA Case Size		NPO 0603 (Continued on next page)											
Length (L)		1.60 ± 0.15											
Width (W)		0.80 ± 0.15											
Termination Width(P)		0.40 ± 0.15											
Capacitance Value	Capacitance Code	Working Voltage (VDC)											
		10V			16V			25V			50V		
		DWV	Q	T max. (mm)	DWV	Q	T max. (mm)	DWV	Q	T max. (mm)	DWV	Q	T max. (mm)
0.47pF	R47										125	409	0.87
0.5pF	0R5	25	410	0.87	40	410	0.87	62.5	410	0.87	125	410	0.87
0.56pF	R56										125	411	0.87
0.6pF	0R6	25	412	0.87	40	412	0.87	62.5	412	0.87	125	412	0.87
0.68pF	R68										125	414	0.87
0.7pF	0R7	25	414	0.87	40	414	0.87	62.5	414	0.87	125	414	0.87
0.8pF	0R8	25	416	0.87	40	416	0.87	62.5	416	0.87	125	416	0.87
0.82pF	R82										125	416	0.87
0.9pF	0R9	25	418	0.87	40	418	0.87	62.5	418	0.87	125	418	0.87
1.0pF	1R0	25	420	0.87	40	420	0.87	62.5	420	0.87	125	420	0.87
1.2pF	1R2	25	424	0.87	40	424	0.87	62.5	424	0.87	125	424	0.87
1.5pF	1R5	25	430	0.87	40	430	0.87	62.5	430	0.87	125	430	0.87
1.8pF	1R8	25	436	0.87	40	436	0.87	62.5	436	0.87	125	436	0.87
2.2pF	2R2	25	444	0.87	40	444	0.87	62.5	444	0.87	125	444	0.87
2.7pF	2R7	25	454	0.87	40	454	0.87	62.5	454	0.87	125	454	0.87
3.3pF	3R3	25	466	0.87	40	466	0.87	62.5	466	0.87	125	466	0.87
3.9pF	3R9	25	478	0.87	40	478	0.87	62.5	478	0.87	125	478	0.87
4.7pF	4R7	25	494	0.87	40	494	0.87	62.5	494	0.87	125	494	0.87
5.6pF	5R6	25	512	0.87	40	512	0.87	62.5	512	0.87	125	512	0.87
6.8pF	6R8	25	536	0.87	40	536	0.87	62.5	536	0.87	125	536	0.87
8.2pF	8R2	25	564	0.87	40	564	0.87	62.5	564	0.87	125	564	0.87
10pF	100	25	600	0.87	40	600	0.87	62.5	600	0.87	125	600	0.87
12pF	120	25	640	0.87	40	640	0.87	62.5	640	0.87	125	640	0.87
15pF	150	25	700	0.87	40	700	0.87	62.5	700	0.87	125	700	0.87
18pF	180	25	760	0.87	40	760	0.87	62.5	760	0.87	125	760	0.87
22pF	220	25	840	0.87	40	840	0.87	62.5	840	0.87	125	840	0.87
27pF	270	25	940	0.87	40	940	0.87	62.5	940	0.87	125	940	0.87
33pF	330	25	1000	0.87	40	1000	0.87	62.5	1000	0.87	125	1000	0.87
39pF	390	25	1000	0.87	40	1000	0.87	62.5	1000	0.87	125	1000	0.87
47pF	470	25	1000	0.87	40	1000	0.87	62.5	1000	0.87	125	1000	0.87
56pF	560	25	1000	0.87	40	1000	0.87	62.5	1000	0.87	125	1000	0.87
68pF	680	25	1000	0.87	40	1000	0.87	62.5	1000	0.87	125	1000	0.87
82pF	820	25	1000	0.87	40	1000	0.87	62.5	1000	0.87	125	1000	0.87
100pF	101	25	1000	0.87	40	1000	0.87	62.5	1000	0.87	125	1000	0.87
120pF	121	25	1000	0.87	40	1000	0.87	62.5	1000	0.87	125	1000	0.87
150pF	151	25	1000	0.87	40	1000	0.87	62.5	1000	0.87	125	1000	0.87
180pF	181	25	1000	0.87	40	1000	0.87	62.5	1000	0.87	125	1000	0.87
220pF	221	25	1000	0.87	40	1000	0.87	62.5	1000	0.87	125	1000	0.87
270pF	271	25	1000	0.87	40	1000	0.87	62.5	1000	0.87	125	1000	0.87
330pF	331	25	1000	0.87	40	1000	0.87	62.5	1000	0.87	125	1000	0.87
390pF	391	25	1000	0.87	40	1000	0.87	62.5	1000	0.87	125	1000	0.87
470pF	471	25	1000	0.87	40	1000	0.87	62.5	1000	0.87	125	1000	0.87
560pF	561	25	1000	0.87	40	1000	0.87	62.5	1000	0.87	125	1000	0.87
680pF	681	25	1000	0.87	40	1000	0.87	62.5	1000	0.87	125	1000	0.87
820pF	821	25	1000	0.87	40	1000	0.87	62.5	1000	0.87	125	1000	0.87
1,000pF	102	25	1000	0.87	40	1000	0.87	62.5	1000	0.87	125	1000	0.87
1,200pF	122	25	1000	0.95	40	1000	0.95	62.5	1000	0.95	125	1000	0.95
1,500pF	152	25	1000	0.95	40	1000	0.95	62.5	1000	0.95	125	1000	0.95
1,800pF	182	25	1000	0.95	40	1000	0.95	62.5	1000	0.95	125	1000	0.95
2,200pF	222	25	1000	0.95	40	1000	0.95	62.5	1000	0.95	125	1000	0.95
2,700pF	272	25	1000	0.95	40	1000	0.95	62.5	1000	0.95	125	1000	0.95
3,300pF	332	25	1000	0.95	40	1000	0.95	62.5	1000	0.95	125	1000	0.95

Specifications in BLACK = Production Code 3

Specifications in BLUE = Production Code 4



NPO STANDARD VALUES AND SPECIFICATIONS

EIA Case Size		NPO 0603								
Length (L)		1.60 ± 0.15								
Width (W)		0.80 ± 0.15								
Termination Width (P)		0.40 ± 0.15								
Capacitance Value	Capacitance Code	Working Voltage (VDC)								
		100V			200V			250V		
		DWV	Q	T max. (mm)	DWV	Q	T max. (mm)	DWV	Q	T max. (mm)
0.47pF	R47	250	410	0.87				250	409	0.87
0.5pF	0R5	250	410	0.87	400	410	0.87	500	410	0.87
0.56pF	R56	250	410	0.87				250	411	0.87
0.6pF	0R6	250	412	0.87	400	412	0.87	500	412	0.87
0.68pF	R68	250	412	0.87				250	414	0.87
0.7pF	0R7	250	414	0.87	400	414	0.87	500	414	0.87
0.8pF	0R8	250	416	0.87	400	416	0.87	500	416	0.87
0.82pF	R82	250	416	0.87				250	416	0.87
0.9pF	0R9	250	418	0.87	400	418	0.87	500	418	0.87
1.0pF	1R0	250	420	0.87	400	420	0.87	500	420	0.87
1.2pF	1R2	250	424	0.87	400	424	0.87	500	424	0.87
1.5pF	1R5	250	430	0.87	400	430	0.87	500	430	0.87
1.8pF	1R8	250	436	0.87	400	436	0.87	500	436	0.87
2.2pF	2R2	250	444	0.87	400	444	0.87	500	444	0.87
2.7pF	2R7	250	454	0.87	400	454	0.87	500	454	0.87
3.3pF	3R3	250	466	0.87	400	466	0.87	500	466	0.87
3.9pF	3R9	250	478	0.87	400	478	0.87	500	478	0.87
4.7pF	4R7	250	494	0.87	400	494	0.87	500	494	0.87
5.6pF	5R6	250	512	0.87	400	512	0.87	500	512	0.87
6.8pF	6R8	250	536	0.87	400	536	0.87	500	536	0.87
8.2pF	8R2	250	564	0.87	400	564	0.87	500	564	0.87
10pF	100	250	600	0.87	400	600	0.87	500	600	0.87
12pF	120	250	640	0.87	400	640	0.87	500	640	0.87
15pF	150	250	700	0.87	400	700	0.87	500	700	0.87
18pF	180	250	760	0.87	400	760	0.87	500	760	0.87
22pF	220	250	840	0.87	400	840	0.87	500	840	0.87
27pF	270	250	940	0.87	400	940	0.87	500	940	0.87
33pF	330	250	1000	0.87	400	1000	0.87	500	1000	0.87
39pF	390	250	1000	0.87	400	1000	0.87	500	1000	0.87
47pF	470	250	1000	0.87	400	1000	0.87	500	1000	0.87
56pF	560	250	1000	0.87	400	1000	0.87	500	1000	0.87
68pF	680	250	1000	0.87	400	1000	0.87	500	1000	0.87
82pF	820	250	1000	0.87	400	1000	0.87	500	1000	0.87
100pF	101	250	1000	0.87	400	1000	0.87	500	1000	0.87
120pF	121	250	1000	0.87	500	1000	0.87	500	1000	0.87
150pF	151	250	1000	0.87	500	1000	0.87	500	1000	0.87
180pF	181	250	1000	0.87	500	1000	0.87	500	1000	0.87
220pF	221	250	1000	0.87	500	1000	0.87	500	1000	0.87
270pF	271	250	1000	0.87	500	1000	0.95	500	1000	0.87
330pF	331	250	1000	0.87	500	1000	0.95	500	1000	0.95
390pF	391	250	1000	0.87	500	1000	0.95	500	1000	0.95
470pF	471	250	1000	0.87	500	1000	0.95	500	1000	0.95
560pF	561	250	1000	0.87				500	1000	0.95
680pF	681	250	1000	0.87				500	1000	0.95
820pF	821	250	1000	0.87						
1,000pF	102	250	1000	0.87						

Specifications in BLACK = Production Code 3
 Specifications in BLUE = Production Code 4



NPO STANDARD VALUES AND SPECIFICATIONS

EIA Case Size		NPO 0805 (Continued on next page)											
Length (L)		2.00 ± 0.20											
Width (W)		1.25 ± 0.20											
Termination Width (P)		0.50 ± 0.20											
Capacitance Value	Capacitance Code	Working Voltage (VDC)											
		10V			16V			25V			50V		
		DWV	Q	T max. (mm)	DWV	Q	T max. (mm)	DWV	Q	T max. (mm)	DWV	Q	T max. (mm)
0.47pF	R47										125	409	0.7
0.5pF	0R5	25	410	0.7	40	410	0.7	62.5	410	0.7	125	410	0.7
0.56pF	R56										125	411	0.7
0.6pF	0R6	25	412	0.7	40	412	0.7	62.5	412	0.7	125	412	0.7
0.68pF	R68										125	414	0.7
0.7pF	0R7	25	414	0.7	40	414	0.7	62.5	414	0.7	125	414	0.7
0.8pF	0R8	25	416	0.7	40	416	0.7	62.5	416	0.7	125	416	0.7
0.82pF	R82										125	416	0.7
0.9pF	0R9	25	418	0.7	40	418	0.7	62.5	418	0.7	125	418	0.7
1.0pF	1R0	25	420	0.7	40	420	0.7	62.5	420	0.7	125	420	0.7
1.2pF	1R2	25	424	0.7	40	424	0.7	62.5	424	0.7	125	424	0.7
1.5pF	1R5	25	430	0.7	40	430	0.7	62.5	430	0.7	125	430	0.7
1.8pF	1R8	25	436	0.7	40	436	0.7	62.5	436	0.7	125	436	0.7
2.2pF	2R2	25	444	0.7	40	444	0.7	62.5	444	0.7	125	444	0.7
2.7pF	2R7	25	454	0.7	40	454	0.7	62.5	454	0.7	125	454	0.7
3.3pF	3R3	25	466	0.7	40	466	0.7	62.5	466	0.7	125	466	0.7
3.9pF	3R9	25	478	0.7	40	478	0.7	62.5	478	0.7	125	478	0.7
4.7pF	4R7	25	494	0.7	40	494	0.7	62.5	494	0.7	125	494	0.7
5.6pF	5R6	25	512	0.7	40	512	0.7	62.5	512	0.7	125	512	0.7
6.8pF	6R8	25	536	0.7	40	536	0.7	62.5	536	0.7	125	536	0.7
8.2pF	8R2	25	564	0.7	40	564	0.7	62.5	564	0.7	125	564	0.7
10pF	100	25	600	0.7	40	600	0.7	62.5	600	0.7	125	600	0.7
12pF	120	25	640	0.7	40	640	0.7	62.5	640	0.7	125	640	0.7
15pF	150	25	700	0.7	40	700	0.7	62.5	700	0.7	125	700	0.7
18pF	180	25	760	0.7	40	760	0.7	62.5	760	0.7	125	760	0.7
22pF	220	25	840	0.7	40	840	0.7	62.5	840	0.7	125	840	0.7
27pF	270	25	940	0.7	40	940	0.7	62.5	940	0.7	125	940	0.7
33pF	330	25	1000	0.7	40	1000	0.7	62.5	1000	0.7	125	1000	0.7
39pF	390	25	1000	0.7	40	1000	0.7	62.5	1000	0.7	125	1000	0.7
47pF	470	25	1000	0.7	40	1000	0.7	62.5	1000	0.7	125	1000	0.7
56pF	560	25	1000	0.7	40	1000	0.7	62.5	1000	0.7	125	1000	0.7
68pF	680	25	1000	0.7	40	1000	0.7	62.5	1000	0.7	125	1000	0.7
82pF	820	25	1000	0.7	40	1000	0.7	62.5	1000	0.7	125	1000	0.7
100pF	101	25	1000	0.7	40	1000	0.7	62.5	1000	0.7	125	1000	0.7
120pF	121	25	1000	0.7	40	1000	0.7	62.5	1000	0.7	125	1000	0.7
150pF	151	25	1000	0.7	40	1000	0.7	62.5	1000	0.7	125	1000	0.7
180pF	181	25	1000	0.7	40	1000	0.7	62.5	1000	0.7	125	1000	0.7
220pF	221	25	1000	0.7	40	1000	0.7	62.5	1000	0.7	125	1000	0.7
270pF	271	25	1000	0.7	40	1000	0.7	62.5	1000	0.7	125	1000	0.7
330pF	331	25	1000	0.7	40	1000	0.7	62.5	1000	0.7	125	1000	0.7
390pF	391	25	1000	0.95	40	1000	0.95	62.5	1000	0.95	125	1000	0.95
470pF	471	25	1000	0.95	40	1000	0.95	62.5	1000	0.95	125	1000	0.95
560pF	561	25	1000	0.95	40	1000	0.95	62.5	1000	0.95	125	1000	0.95
680pF	681	25	1000	0.95	40	1000	0.95	62.5	1000	0.95	125	1000	0.95
820pF	821	25	1000	0.95	40	1000	0.95	62.5	1000	0.95	125	1000	0.95
1,000pF	102	25	1000	0.95	40	1000	0.95	62.5	1000	0.95	125	1000	0.95
1,200pF	122	25	1000	0.95	40	1000	0.95	62.5	1000	0.95	125	1000	0.95
1,500pF	152	25	1000	0.95	40	1000	0.95	62.5	1000	0.95	125	1000	0.95
1,800pF	182	25	1000	0.95	40	1000	0.95	62.5	1000	0.95	125	1000	0.95
2,200pF	222	25	1000	0.95	40	1000	0.95	62.5	1000	0.95	125	1000	0.95
2,700pF	272	25	1000	1.35	40	1000	1.35	62.5	1000	1.35	125	1000	1.35
3,300pF	332	25	1000	1.35	40	1000	1.35	62.5	1000	1.35	125	1000	1.35
3,900pF	392	25	1000	1.35	40	1000	1.35	62.5	1000	1.35	125	1000	1.35
4,700pF	472	25	1000	1.35	40	1000	1.35	62.5	1000	1.35	125	1000	1.35
5,600pF	562	25	1000	1.35	40	1000	1.35	62.5	1000	1.35	125	1000	1.35

Specifications in BLACK = Production Code 3

Specifications in BLUE = Production Code 4



NPO STANDARD VALUES AND SPECIFICATIONS

EIA Case Size		NPO 0805 (Continued on next page)											
Length (L)		2.00 ± 0.20											
Width (W)		1.25 ± 0.20											
Termination Width (P)		0.50 ± 0.20											
Capacitance Value	Capacitance Code	Working Voltage (VDC)											
		10V			16V			25V			50V		
		DWV	Q	T max. (mm)	DWV	Q	T max. (mm)	DWV	Q	T max. (mm)	DWV	Q	T max. (mm)
6,800pF	682	25	1000	1.35	40	1000	1.35	62.5	1000	1.35	125	1000	1.35
8,200pF	822	25	1000	1.35	40	1000	1.35	62.5	1000	1.35	125	1000	1.35
10,000pF	103	25	1000	1.35	40	1000	1.35	62.5	1000	1.35	125	1000	1.35

(CONSULT FACTORY FOR CAPACITANCE VALUES NOT LISTED)

Specifications in BLACK = Production Code 3
 Specifications in BLUE = Production Code 4

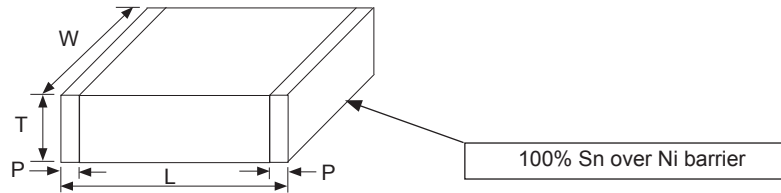

NPO STANDARD VALUES AND SPECIFICATIONS

EIA Case Size		NPO 0805								
Length (L)		2.00 ± 0.20								
Width (W)		1.25 ± 0.20								
Termination Width(P)		0.50 ± 0.20								
Capacitance Value	Capacitance Code	Working Voltage (VDC)								
		100V			200V			250V		
		DWV	Q	T max. (mm)	DWV	Q	T max. (mm)	DWV	Q	T max. (mm)
0.47pF	R47	250	409	0.7				500	409	0.7
0.5pF	0R5	250	410	0.7	500	410	0.7	500	410	0.7
0.56pF	R56	250	411	0.7				500	411	0.7
0.6pF	0R6	250	412	0.7	500	412	0.7	500	412	0.7
0.68pF	R68	250	414	0.7				500	414	0.7
0.7pF	0R7	250	414	0.7	500	414	0.7	500	414	0.7
0.8pF	0R8	250	416	0.7	500	416	0.7	500	416	0.7
0.82pF	R82	250	416	0.7				500	416	0.7
0.9pF	0R9	250	418	0.7	500	418	0.7	500	418	0.7
1.0pF	1R0	250	420	0.7	500	420	0.7	500	420	0.7
1.2pF	1R2	250	424	0.7	500	424	0.7	500	424	0.7
1.5pF	1R5	250	430	0.7	500	430	0.7	500	430	0.7
1.8pF	1R8	250	436	0.7	500	436	0.7	500	436	0.7
2.2pF	2R2	250	444	0.7	500	444	0.7	500	444	0.7
2.7pF	2R7	250	454	0.7	500	454	0.7	500	454	0.7
3.3pF	3R3	250	466	0.7	500	466	0.7	500	466	0.7
3.9pF	3R9	250	478	0.7	500	478	0.7	500	478	0.7
4.7pF	4R7	250	494	0.7	500	494	0.7	500	494	0.7
5.6pF	5R6	250	512	0.7	500	512	0.7	500	512	0.7
6.8pF	6R8	250	536	0.7	500	536	0.7	500	536	0.7
8.2pF	8R2	250	564	0.7	500	564	0.7	500	564	0.7
10pF	100	250	600	0.7	500	600	0.7	500	600	0.7
12pF	120	250	640	0.7	500	640	0.7	500	640	0.7
15pF	150	250	700	0.7	500	700	0.7	500	700	0.7
18pF	180	250	760	0.7	500	760	0.7	500	760	0.7
22pF	220	250	840	0.7	500	840	0.7	500	840	0.7
27pF	270	250	940	0.7	500	940	0.7	500	940	0.7
33pF	330	250	1000	0.7	500	1000	0.7	500	1000	0.7
39pF	390	250	1000	0.7	500	1000	0.7	500	1000	0.7
47pF	470	250	1000	0.7	500	1000	0.7	500	1000	0.7
56pF	560	250	1000	0.7	500	1000	0.7	500	1000	0.7
68pF	680	250	1000	0.7	500	1000	0.7	500	1000	0.7
82pF	820	250	1000	0.7	500	1000	0.7	500	1000	0.7
100pF	101	250	1000	0.7	500	1000	0.9	500	1000	0.9
120pF	121	250	1000	0.7	500	1000	0.9	500	1000	0.9
150pF	151	250	1000	0.7	500	1000	1.35	500	1000	1.35
180pF	181	250	1000	0.7	500	1000	1.35	500	1000	1.35
220pF	221	250	1000	0.7	500	1000	1.35	500	1000	1.35
270pF	271	250	1000	0.7	500	1000	1.35	500	1000	1.35
330pF	331	250	1000	0.7	500	1000	1.35	500	1000	1.35
390pF	391	250	1000	0.9	500	1000	1.35	500	1000	1.35
470pF	471	250	1000	0.9	500	1000	1.35	500	1000	1.35
560pF	561	250	1000	0.9	500	1000	1.35	500	1000	1.35
680pF	681	250	1000	0.9	500	1000	1.35	500	1000	1.35
820pF	821	250	1000	0.9	500	1000	1.35	500	1000	1.35
1,000pF	102	250	1000	0.9	500	1000	1.35	500	1000	1.35
1,200pF	122	250	1000	0.9	500	1000	1.35	500	1000	1.35
1,500pF	152	250	1000	0.9	500	1000	1.35	500	1000	1.35
1,800pF	182	250	1000	0.9	500	1000	1.35	500	1000	1.35
2,200pF	222	250	1000	0.9	500	1000	1.35	500	1000	1.35
2,700pF	272	250	1000	1.35						
3,300pF	332	250	1000	1.35						
3,900pF	392	250	1000	1.35						
4,700pF	472	250	1000	1.35						
5,600pF	562	250	1000	1.35						
6,800pF	682	250	1000	1.35						



Specifications in BLACK = Production Code 3, Specifications in BLUE = Production Code 4

NPO STANDARD VALUES AND SPECIFICATIONS

EIA Case Size		NPO 0805					
Length (L)		2.00 ± 0.20					
Width (W)		1.25 ± 0.20					
Termination Width(P)		0.50 ± 0.20					
Capacitance Value	Capacitance Code	Working Voltage (VDC)					
		500V			630V		
		DWV	Q	T max. (mm)	DWV	Q	T max. (mm)
0.5pF	0R5	750	410	0.7	945	410	0.7
0.6pF	0R6	750	412	0.7	945	412	0.7
0.7pF	0R7	750	414	0.7	945	414	0.7
0.8pF	0R8	750	416	0.7	945	416	0.7
0.9pF	0R9	750	418	0.7	945	418	0.7
1.0pF	1R0	750	420	0.7	945	420	0.7
1.2pF	1R2	750	424	0.7	945	424	0.7
1.5pF	1R5	750	430	0.7	945	430	0.7
1.8pF	1R8	750	436	0.7	945	436	0.7
2.2pF	2R2	750	444	0.7	945	444	0.7
2.7pF	2R7	750	454	0.7	945	454	0.7
3.3pF	3R3	750	466	0.7	945	466	0.7
3.9pF	3R9	750	478	0.7	945	478	0.7
4.7pF	4R7	750	494	0.7	945	494	0.7
5.6pF	5R6	750	512	0.7	945	512	0.7
6.8pF	6R8	750	536	0.7	945	536	0.7
8.2pF	8R2	750	564	0.7	945	564	0.7
10pF	100	750	600	0.7	945	600	0.7
12pF	120	750	640	0.7	945	640	0.7
15pF	150	750	700	0.7	945	700	0.7
18pF	180	750	760	0.7	945	760	0.7
22pF	220	750	840	0.7	945	840	0.7
27pF	270	750	940	0.7	945	940	0.7
33pF	330	750	1000	0.7	945	1000	0.7
39pF	390	750	1000	0.7	945	1000	0.7
47pF	470	750	1000	0.7	945	1000	0.7
56pF	560	750	1000	0.7	945	1000	0.7
68pF	680	750	1000	0.7	945	1000	0.7
82pF	820	750	1000	0.9	945	1000	0.9
100pF	101	750	1000	0.9	945	1000	0.9
120pF	121	750	1000	1.35	945	1000	1.35
150pF	151	750	1000	1.35	945	1000	1.35
180pF	181	750	1000	1.35	945	1000	1.35
220pF	221	750	1000	1.35	945	1000	1.35
270pF	271	750	1000	1.35	945	1000	1.35
330pF	331	750	1000	1.35	945	1000	1.35
390pF	391	750	1000	1.35	945	1000	1.35

(CONSULT FACTORY FOR CAPACITANCE VALUES NOT LISTED)

Specifications in BLACK = Production Code 3
Specifications in BLUE = Production Code 4

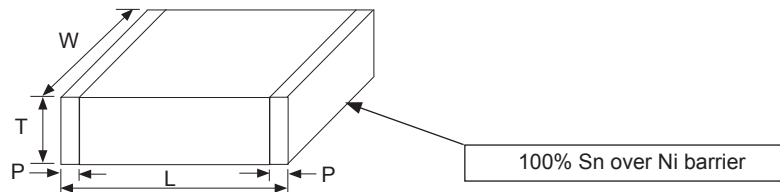

EIA Case Size		NPO 1206											
Length (L)		3.20 ±0.30											
Width (W)		1.60 ± 0.30											
Termination Width(P)		0.60 ± 0.20											
Capacitance Value	Capacitance Code	Working Voltage (VDC)											
		10V			16V			25V			50V		
		DWV	Q	T max. (mm)	DWV	Q	T max. (mm)	DWV	Q	T max. (mm)	DWV	Q	T max. (mm)
1.2pF	1R2	25	424	0.9	40	424	0.9	62.5	424	0.9	125	424	0.9
1.5pF	1R5	25	430	0.9	40	430	0.9	62.5	430	0.9	125	430	0.9
1.8pF	1R8	25	436	0.9	40	436	0.9	62.5	436	0.9	125	436	0.9
2.2pF	2R2	25	444	0.9	40	444	0.9	62.5	444	0.9	125	444	0.9
2.7pF	2R7	25	454	0.9	40	454	0.9	62.5	454	0.9	125	454	0.9
3.3pF	3R3	25	466	0.9	40	466	0.9	62.5	466	0.9	125	466	0.9
3.9pF	3R9	25	478	0.9	40	478	0.9	62.5	478	0.9	125	478	0.9
4.7pF	4R7	25	494	0.9	40	494	0.9	62.5	494	0.9	125	494	0.9
5.6pF	5R6	25	512	0.9	40	512	0.9	62.5	512	0.9	125	512	0.9
6.8pF	6R8	25	536	0.9	40	536	0.9	62.5	536	0.9	125	536	0.9
8.2pF	8R2	25	564	0.9	40	564	0.9	62.5	564	0.9	125	564	0.9
10pF	100	25	600	0.9	40	600	0.9	62.5	600	0.9	125	600	0.9
12pF	120	25	640	0.9	40	640	0.9	62.5	640	0.9	125	640	0.9
15pF	150	25	700	0.9	40	700	0.9	62.5	700	0.9	125	700	0.9
18pF	180	25	760	0.9	40	760	0.9	62.5	760	0.9	125	760	0.9
22pF	220	25	840	0.9	40	840	0.9	62.5	840	0.9	125	840	0.9
27pF	270	25	940	0.9	40	940	0.9	62.5	940	0.9	125	940	0.9
33pF	330	25	1000	0.9	40	1000	0.9	62.5	1000	0.9	125	1000	0.9
39pF	390	25	1000	0.9	40	1000	0.9	62.5	1000	0.9	125	1000	0.9
47pF	470	25	1000	0.9	40	1000	0.9	62.5	1000	0.9	125	1000	0.9
56pF	560	25	1000	0.9	40	1000	0.9	62.5	1000	0.9	125	1000	0.9
68pF	680	25	1000	0.9	40	1000	0.9	62.5	1000	0.9	125	1000	0.9
82pF	820	25	1000	0.9	40	1000	0.9	62.5	1000	0.9	125	1000	0.9
100pF	101	25	1000	0.9	40	1000	0.9	62.5	1000	0.9	125	1000	0.9
120pF	121	25	1000	0.9	40	1000	0.9	62.5	1000	0.9	125	1000	0.9
150pF	151	25	1000	0.9	40	1000	0.9	62.5	1000	0.9	125	1000	0.9
180pF	181	25	1000	0.9	40	1000	0.9	62.5	1000	0.9	125	1000	0.9
220pF	221	25	1000	0.9	40	1000	0.9	62.5	1000	0.9	125	1000	0.9
270pF	271	25	1000	0.9	40	1000	0.9	62.5	1000	0.9	125	1000	0.9
330pF	331	25	1000	0.9	40	1000	0.9	62.5	1000	0.9	125	1000	0.9
390pF	391	25	1000	0.9	40	1000	0.9	62.5	1000	0.9	125	1000	0.9
470pF	471	25	1000	0.9	40	1000	0.9	62.5	1000	0.9	125	1000	0.9
560pF	561	25	1000	0.9	40	1000	0.9	62.5	1000	0.9	125	1000	0.9
680pF	681	25	1000	0.9	40	1000	0.9	62.5	1000	0.9	125	1000	0.9
820pF	821	25	1000	0.9	40	1000	0.9	62.5	1000	0.9	125	1000	0.9
1,000pF	102	25	1000	0.9	40	1000	0.9	62.5	1000	0.9	125	1000	0.9
1,200pF	122	25	1000	0.9	40	1000	0.9	62.5	1000	0.9	125	1000	0.9
1,500pF	152	25	1000	0.9	40	1000	0.9	62.5	1000	0.9	125	1000	0.9
1,800pF	182	25	1000	0.9	40	1000	0.9	62.5	1000	0.9	125	1000	0.9
2,200pF	222	25	1000	0.9	40	1000	0.9	62.5	1000	0.9	125	1000	0.9
2,700pF	272	25	1000	0.9	40	1000	0.9	62.5	1000	0.9	125	1000	0.9
3,300pF	332	25	1000	0.9	40	1000	0.9	62.5	1000	0.9	125	1000	0.9
3,900pF	392	25	1000	0.9	40	1000	0.9	62.5	1000	0.9	125	1000	0.9
4,700pF	472	25	1000	0.9	40	1000	0.9	62.5	1000	0.9	125	1000	0.9
5,600pF	562	25	1000	0.9	40	1000	0.9	62.5	1000	0.9	125	1000	0.9
6,800pF	682	25	1000	1.05	40	1000	1.05	62.5	1000	1.05	125	1000	1.05
8,200pF	822	25	1000	1.35	40	1000	1.35	62.5	1000	1.35	125	1000	1.35
10,000pF	103	25	1000	1.35	40	1000	1.35	62.5	1000	1.35	125	1000	1.35
0.012µF	123	25	1000	1.9	40	1000	1.9	62.5	1000	1.9	125	1000	1.9
0.015µF	153	25	1000	1.9	40	1000	1.9	62.5	1000	1.9	125	1000	1.9
0.018µF	183	25	1000	1.9	40	1000	1.9	62.5	1000	1.9	125	1000	1.9
0.022µF	223	25	1000	1.9	40	1000	1.9	62.5	1000	1.9	125	1000	1.9
0.027µF	273	25	1000	1.9	40	1000	1.9	62.5	1000	1.9	125	1000	1.9
0.033µF	333	25	1000	1.9	40	1000	1.9	62.5	1000	1.9	125	1000	1.9
0.039µF	393	25	1000	1.9	40	1000	1.9	62.5	1000	1.9	125	1000	1.9

Specifications in BLACK = Production Code 3
 Specifications in BLUE = Production Code 4



NPO STANDARD VALUES AND SPECIFICATIONS

EIA Case Size		NPO 1206 (Continued on next page)								
Length (L)		3.20 ±0.30								
Width (W)		1.60 ± 0.30								
Termination Width(P)		0.60 ± 0.20								
Capacitance Value	Capacitance Code	Working Voltage (VDC)								
		100V			200V			250V		
		DWV	Q	T max. (mm)	DWV	Q	T max. (mm)	DWV	Q	T max. (mm)
1.2pF	1R2	250	424	0.9	500	424	0.9	500	424	0.9
1.5pF	1R5	250	430	0.9	500	430	0.9	500	430	0.9
1.8pF	1R8	250	436	0.9	500	436	0.9	500	436	0.9
2.2pF	2R2	250	444	0.9	500	444	0.9	500	444	0.9
2.7pF	2R7	250	454	0.9	500	454	0.9	500	454	0.9
3.3pF	3R3	250	466	0.9	500	466	0.9	500	466	0.9
3.9pF	3R9	250	478	0.9	500	478	0.9	500	478	0.9
4.7pF	4R7	250	494	0.9	500	494	0.9	500	494	0.9
5.6pF	5R6	250	512	0.9	500	512	0.9	500	512	0.9
6.8pF	6R8	250	536	0.9	500	536	0.9	500	536	0.9
8.2pF	8R2	250	564	0.9	500	564	0.9	500	564	0.9
10pF	100	250	600	0.9	500	600	0.9	500	600	0.9
12pF	120	250	640	0.9	500	640	0.9	500	640	0.9
15pF	150	250	700	0.9	500	700	0.9	500	700	0.9
18pF	180	250	760	0.9	500	760	0.9	500	760	0.9
22pF	220	250	840	0.9	500	840	0.9	500	840	0.9
27pF	270	250	940	0.9	500	940	0.9	500	940	0.9
33pF	330	250	1000	0.9	500	1000	0.9	500	1000	0.9
39pF	390	250	1000	0.9	500	1000	0.9	500	1000	0.9
47pF	470	250	1000	0.9	500	1000	0.9	500	1000	0.9
56pF	560	250	1000	0.9	500	1000	0.9	500	1000	0.9
68pF	680	250	1000	0.9	500	1000	0.9	500	1000	0.9
82pF	820	250	1000	0.9	500	1000	0.9	500	1000	0.9
100pF	101	250	1000	0.9	500	1000	0.9	500	1000	0.9
120pF	121	250	1000	0.9	500	1000	0.9	500	1000	0.9
150pF	151	250	1000	0.9	500	1000	0.9	500	1000	0.9
180pF	181	250	1000	0.9	500	1000	0.9	500	1000	0.9
220pF	221	250	1000	0.9	500	1000	0.9	500	1000	0.9
270pF	271	250	1000	0.9	500	1000	0.9	500	1000	1.05
330pF	331	250	1000	0.9	500	1000	0.9	500	1000	1.05
390pF	391	250	1000	0.9	500	1000	0.9	500	1000	1.05
470pF	471	250	1000	0.9	500	1000	1.05	500	1000	1.05
560pF	561	250	1000	0.9	500	1000	1.05	500	1000	1.35
680pF	681	250	1000	0.9	500	1000	1.05	500	1000	1.35
820pF	821	250	1000	0.9	500	1000	1.05	500	1000	1.8
1,000pF	102	250	1000	0.9	500	1000	1.05	500	1000	1.8
1,200pF	122	250	1000	0.9	500	1000	1.05	500	1000	1.8
1,500pF	152	250	1000	0.9	500	1000	1.35	500	1000	1.8
1,800pF	182	250	1000	0.9	500	1000	1.35	500	1000	1.8
2,200pF	222	250	1000	0.9	500	1000	1.35	500	1000	1.8
2,700pF	272	250	1000	0.9	500	1000	1.35	500	1000	1.8
3,300pF	332	250	1000	0.9	500	1000	1.35	500	1000	1.8
3,900pF	392	250	1000	0.9	500	1000	1.35	500	1000	1.8
4,700pF	472	250	1000	0.9	500	1000	1.35	500	1000	1.8
5,600pF	562	250	1000	0.9						
6,800pF	682	250	1000	1.05						
8,200pF	822	250	1000	1.35						
10,000pF	103	250	1000	1.35						
0.012μF	123	250	1000	1.9						
0.015μF	153	250	1000	1.9						
0.018μF	183	250	1000	1.9						
0.022μF	223	250	1000	1.9						

Specifications in BLACK = Production Code 3
 Specifications in BLUE = Production Code 4



NPO STANDARD VALUES AND SPECIFICATIONS

EIA Case Size		NPO 1206					
Length (L)		3.2 ±0.30					
Width (W)		1.60 ± 0.30					
Termination Width(P)		0.60 ± 0.20					
Capacitance Value	Capacitance Code	Working Voltage (VDC)					
		500V			630V		
		DWV	Q	T max. (mm)	DWV	Q	T max. (mm)
1.2pF	1R2	750	424	0.9	945	424	0.9
1.5pF	1R5	750	430	0.9	945	430	0.9
1.8pF	1R8	750	436	0.9	945	436	0.9
2.2pF	2R2	750	444	0.9	945	444	0.9
2.7pF	2R7	750	454	0.9	945	454	0.9
3.3pF	3R3	750	466	0.9	945	466	0.9
3.9pF	3R9	750	478	0.9	945	478	0.9
4.7pF	4R7	750	494	0.9	945	494	0.9
5.6pF	5R6	750	512	0.9	945	512	0.9
6.8pF	6R8	750	536	0.9	945	536	0.9
8.2pF	8R2	750	564	0.9	945	564	0.9
10pF	100	750	600	0.9	945	600	0.9
12pF	120	750	640	0.9	945	640	0.9
15pF	150	750	700	0.9	945	700	0.9
18pF	180	750	760	0.9	945	760	0.9
22pF	220	750	840	0.9	945	840	0.9
27pF	270	750	940	0.9	945	940	0.9
33pF	330	750	1000	0.9	945	1000	0.9
39pF	390	750	1000	0.9	945	1000	0.9
47pF	470	750	1000	0.9	945	1000	0.9
56pF	560	750	1000	0.9	945	1000	0.9
68pF	680	750	1000	0.9	945	1000	0.9
82pF	820	750	1000	0.9	945	1000	0.9
100pF	101	750	1000	0.9	945	1000	0.9
120pF	121	750	1000	0.9	945	1000	0.9
150pF	151	750	1000	0.9	945	1000	0.9
180pF	181	750	1000	0.9	945	1000	0.9
220pF	221	750	1000	0.9	945	1000	0.9
270pF	271	750	1000	1.05	945	1000	1.05
330pF	331	750	1000	1.05	945	1000	1.05
390pF	391	750	1000	1.05	945	1000	1.05
470pF	471	750	1000	1.05	945	1000	1.05
560pF	561	750	1000	1.35	945	1000	1.35
680pF	681	750	1000	1.35	945	1000	1.35
820pF	821	750	1000	1.8	945	1000	1.8
1,000pF	102	750	1000	1.8	945	1000	1.8
1,200pF	122	750	1000	1.8	945	1000	1.8
1,500pF	152	750	1000	1.8	945	1000	1.8
1,800pF	182	750	1000	1.8	945	1000	1.8
2,200pF	222	750	1000	1.8	945	1000	1.8

EIA Case Size		NPO 1210		
Length (L)		3.2 ±0.40		
Width (W)		2.50 ± 0.30		
Termination Width(P)		0.75 ± 0.25		
Capacitance Value	Capacitance Code	Working Voltage (VDC)		
		10V		
		DWV	Q	T max. (mm)
10pF	100	25	600	1.05
12pF	120	25	640	1.05
15pF	150	25	700	1.05
18pF	180	25	760	1.05
22pF	220	25	840	1.05
27pF	270	25	940	1.05
33pF	330	25	1000	1.05
39pF	390	25	1000	1.05
47pF	470	25	1000	1.05
56pF	560	25	1000	1.05
68pF	680	25	1000	1.05
82pF	820	25	1000	1.05
100pF	101	25	1000	1.05
120pF	121	25	1000	1.05
150pF	151	25	1000	1.05
180pF	181	25	1000	1.05
220pF	221	25	1000	1.05
270pF	271	25	1000	1.05
330pF	331	25	1000	1.05
390pF	391	25	1000	1.05
470pF	471	25	1000	1.05
560pF	561	25	1000	1.05
680pF	681	25	1000	1.05
820pF	821	25	1000	1.05
1,000pF	102	25	1000	1.05
1,200pF	122	25	1000	1.05
1,500pF	152	25	1000	1.05
1,800pF	182	25	1000	1.05
2,200pF	222	25	1000	1.05
2,700pF	272	25	1000	1.05
3,300pF	332	25	1000	1.05
3,900pF	392	25	1000	1.05
4,700pF	472	25	1000	1.05
5,600pF	562	25	1000	1.05
6,800pF	682	25	1000	1.05
8,200pF	822	25	1000	1.05
10,000pF	103	25	1000	1.05
0.012µF	123	25	1000	1.35
0.015µF	153	25	1000	1.35
0.018µF	183	25	1000	2.2
0.022µF	223	25	1000	2.2
0.027µF	273	25	1000	2.2
0.033µF	333	25	1000	2.2

(CONSULT FACTORY FOR CAPACITANCE VALUES NOT LISTED)

Specifications in BLACK = Production Code 3, Specifications in BLUE = Production Code 4

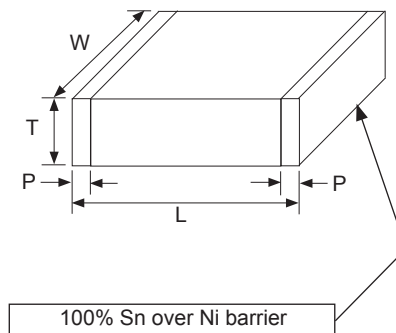

EIA Case Size		NPO 1210 (Continued on next page)											
Length (L)		3.20 ±0.40											
Width (W)		2.50 ± 0.30											
Termination Width(P)		0.75 ± 0.25											
Capacitance Value	Capacitance Code	Working Voltage (VDC)											
		16V			25V			50V			100V		
		DWV	Q	T max. (mm)	DWV	Q	T max. (mm)	DWV	Q	T max. (mm)	DWV	Q	T max. (mm)
10pF	100	40	600	1.05	62.5	600	1.05	125	600	1.05	250	600	1.05
12pF	120	40	640	1.05	62.5	640	1.05	125	640	1.05	250	640	1.05
15pF	150	40	700	1.05	62.5	700	1.05	125	700	1.05	250	700	1.05
18pF	180	40	760	1.05	62.5	760	1.05	125	760	1.05	250	760	1.05
22pF	220	40	840	1.05	62.5	840	1.05	125	840	1.05	250	840	1.05
27pF	270	40	940	1.05	62.5	940	1.05	125	940	1.05	250	940	1.05
33pF	330	40	1000	1.05	62.5	1000	1.05	125	1000	1.05	250	1000	1.05
39pF	390	40	1000	1.05	62.5	1000	1.05	125	1000	1.05	250	1000	1.05
47pF	470	40	1000	1.05	62.5	1000	1.05	125	1000	1.05	250	1000	1.05
56pF	560	40	1000	1.05	62.5	1000	1.05	125	1000	1.05	250	1000	1.05
68pF	680	40	1000	1.05	62.5	1000	1.05	125	1000	1.05	250	1000	1.05
82pF	820	40	1000	1.05	62.5	1000	1.05	125	1000	1.05	250	1000	1.05
100pF	101	40	1000	1.05	62.5	1000	1.05	125	1000	1.05	250	1000	1.05
120pF	121	40	1000	1.05	62.5	1000	1.05	125	1000	1.05	250	1000	1.05
150pF	151	40	1000	1.05	62.5	1000	1.05	125	1000	1.05	250	1000	1.05
180pF	181	40	1000	1.05	62.5	1000	1.05	125	1000	1.05	250	1000	1.05
220pF	221	40	1000	1.05	62.5	1000	1.05	125	1000	1.05	250	1000	1.05
270pF	271	40	1000	1.05	62.5	1000	1.05	125	1000	1.05	250	1000	1.05
330pF	331	40	1000	1.05	62.5	1000	1.05	125	1000	1.05	250	1000	1.05
390pF	391	40	1000	1.05	62.5	1000	1.05	125	1000	1.05	250	1000	1.05
470pF	471	40	1000	1.05	62.5	1000	1.05	125	1000	1.05	250	1000	1.05
560pF	561	40	1000	1.05	62.5	1000	1.05	125	1000	1.05	250	1000	1.05
680pF	681	40	1000	1.05	62.5	1000	1.05	125	1000	1.05	250	1000	1.05
820pF	821	40	1000	1.05	62.5	1000	1.05	125	1000	1.05	250	1000	1.05
1,000pF	102	40	1000	1.05	62.5	1000	1.05	125	1000	1.05	250	1000	1.05
1,200pF	122	40	1000	1.05	62.5	1000	1.05	125	1000	1.05	250	1000	1.05
1,500pF	152	40	1000	1.05	62.5	1000	1.05	125	1000	1.05	250	1000	1.05
1,800pF	182	40	1000	1.05	62.5	1000	1.05	125	1000	1.05	250	1000	1.05
2,200pF	222	40	1000	1.05	62.5	1000	1.05	125	1000	1.05	250	1000	1.05
2,700pF	272	40	1000	1.05	62.5	1000	1.05	125	1000	1.05	250	1000	1.05
3,300pF	332	40	1000	1.05	62.5	1000	1.05	125	1000	1.05	250	1000	1.05
3,900pF	392	40	1000	1.05	62.5	1000	1.05	125	1000	1.05	250	1000	1.05
4,700pF	472	40	1000	1.05	62.5	1000	1.05	125	1000	1.05	250	1000	1.05
5,600pF	562	40	1000	1.05	62.5	1000	1.05	125	1000	1.05	250	1000	1.05
6,800pF	682	40	1000	1.05	62.5	1000	1.05	125	1000	1.05	250	1000	1.05
8,200pF	822	40	1000	1.05	62.5	1000	1.05	125	1000	1.05	250	1000	1.05
10,000pF	103	40	1000	1.05	62.5	1000	1.05	125	1000	1.05	250	1000	1.05
0.012µF	123	40	1000	1.35	62.5	1000	1.35	125	1000	1.35	250	1000	1.35
0.015µF	153	40	1000	1.35	62.5	1000	1.35	125	1000	1.35	250	1000	1.35
0.018µF	183	40	1000	2.2	62.5	1000	2.2	125	1000	2.2	250	1000	2.2
0.022µF	223	40	1000	2.2	62.5	1000	2.2	125	1000	2.2	250	1000	2.2
0.027µF	273	40	1000	2.2	62.5	1000	2.2	125	1000	2.2	250	1000	2.2
0.033µF	333	40	1000	2.2	62.5	1000	2.2	125	1000	2.2	250	1000	2.2

(CONSULT FACTORY FOR CAPACITANCE VALUES NOT LISTED)

Specifications in BLACK = Production Code 3
 Specifications in BLUE = Production Code 4

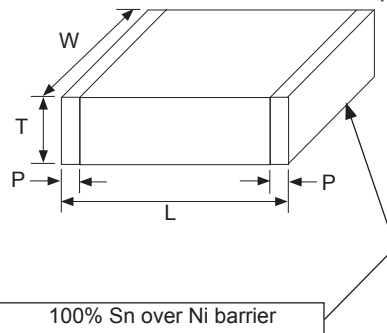

EIA Case Size		NPO 1210											
Length (L)		3.20 ±0.40											
Width (W)		2.50 ± 0.30											
Termination Width(P)		0.75 ± 0.25											
Capacitance Value	Capacitance Code	Working Voltage (VDC)											
		200V			250V			500V			630V		
		DWV	Q	T max. (mm)	DWV	Q	T max. (mm)	DWV	Q	T max. (mm)	DWV	Q	T max. (mm)
10pF	100	500	600	1.05	500	600	1.05	750	600	1.05	750	600	1.05
12pF	120	500	640	1.05	500	640	1.05	750	640	1.05	750	640	1.05
15pF	150	500	700	1.05	500	700	1.05	750	700	1.05	750	700	1.05
18pF	180	500	760	1.05	500	760	1.05	750	760	1.05	750	760	1.05
22pF	220	500	840	1.05	500	840	1.05	750	840	1.05	750	840	1.05
27pF	270	500	940	1.05	500	940	1.05	750	940	1.05	750	940	1.05
33pF	330	500	1000	1.05	500	1000	1.05	750	1000	1.05	750	1000	1.05
39pF	390	500	1000	1.05	500	1000	1.05	750	1000	1.05	750	1000	1.05
47pF	470	500	1000	1.05	500	1000	1.05	750	1000	1.05	750	1000	1.05
56pF	560	500	1000	1.05	500	1000	1.05	750	1000	1.05	750	1000	1.05
68pF	680	500	1000	1.05	500	1000	1.05	750	1000	1.05	750	1000	1.05
82pF	820	500	1000	1.05	500	1000	1.05	750	1000	1.05	750	1000	1.05
100pF	101	500	1000	1.05	500	1000	1.05	750	1000	1.05	750	1000	1.05
120pF	121	500	1000	1.05	500	1000	1.05	750	1000	1.05	750	1000	1.05
150pF	151	500	1000	1.05	500	1000	1.05	750	1000	1.05	750	1000	1.05
180pF	181	500	1000	1.05	500	1000	1.05	750	1000	1.05	750	1000	1.05
220pF	221	500	1000	1.05	500	1000	1.05	750	1000	1.05	750	1000	1.05
270pF	271	500	1000	1.05	500	1000	1.05	750	1000	1.05	750	1000	1.05
330pF	331	500	1000	1.05	500	1000	1.05	750	1000	1.05	750	1000	1.05
390pF	391	500	1000	1.05	500	1000	1.05	750	1000	1.05	750	1000	1.05
470pF	471	500	1000	1.05	500	1000	1.05	750	1000	1.05	750	1000	1.05
560pF	561	500	1000	1.05	500	1000	1.05	750	1000	1.05	750	1000	1.05
680pF	681	500	1000	1.05	500	1000	1.05	750	1000	1.05	750	1000	1.05
820pF	821	500	1000	1.05	500	1000	1.05	750	1000	1.05	750	1000	1.05
1,000pF	102	500	1000	1.35	500	1000	1.35	750	1000	1.35	750	1000	1.35
1,200pF	122	500	1000	1.35	500	1000	1.35	750	1000	1.35	750	1000	1.35
1,500pF	152	500	1000	1.35	500	1000	1.35	750	1000	1.35	750	1000	1.35
1,800pF	182	500	1000	1.35	500	1000	1.35	750	1000	1.35	750	1000	1.35
2,200pF	222	500	1000	1.35	500	1000	1.35	750	1000	1.35	750	1000	1.35
2,700pF	272	500	1000	1.35	500	1000	1.35	750	1000	1.35	750	1000	1.35
3,300pF	332	500	1000	1.35	500	1000	1.35	750	1000	1.35	750	1000	1.35
3,900pF	392	500	1000	1.35	500	1000	1.35	750	1000	1.35	750	1000	1.35
4,700pF	472	500	1000	1.8	500	1000	1.8						
5,600pF	562	500	1000	1.8	500	1000	1.8						
6,800pF	682	500	1000	1.8	500	1000	1.8						
8,200pF	822	500	1000	1.8	500	1000	1.8						
10,000pF	103	500	1000	1.8	500	1000	1.8						
0.012µF	123												
0.015µF	153												
0.018µF	183												
0.022µF	223												
0.027µF	273												
0.033µF	333												

(CONSULT FACTORY FOR CAPACITANCE VALUES NOT LISTED)

Specifications in BLACK = Production Code 3
 Specifications in BLUE = Production Code 4

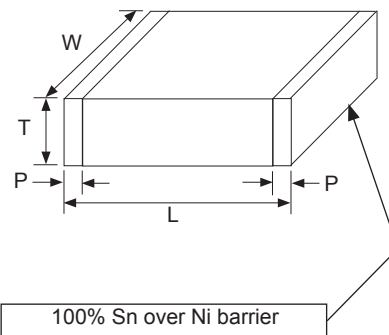

X7R STANDARD VALUES AND SPECIFICATIONS

EIA Case Size		X7R 0402											
Length (L)		1.0 ± 0.05											
Width (W)		0.5 ± 0.05											
Termination Width(P)		0.25 ± 0.1											
Capacitance Value	Capacitance Code	Working Voltage (VDC)											
		10V			16V			25V			50V		
		DWV	DF (%)	T max. (mm)	DWV	DF (%)	T max. (mm)	DWV	DF (%)	T max. (mm)	DWV	DF (%)	T max. (mm)
100pF	101	25	5.0	0.55	40	3.5	0.55	62.5	3.5	0.55	125	2.5	0.55
120pF	121	25	5.0	0.55	40	3.5	0.55	62.5	3.5	0.55	125	2.5	0.55
150pF	151	25	5.0	0.55	40	3.5	0.55	62.5	3.5	0.55	125	2.5	0.55
180pF	181	25	5.0	0.55	40	3.5	0.55	62.5	3.5	0.55	125	2.5	0.55
220pF	221	25	5.0	0.55	40	3.5	0.55	62.5	3.5	0.55	125	2.5	0.55
270pF	271	25	5.0	0.55	40	3.5	0.55	62.5	3.5	0.55	125	2.5	0.55
330pF	331	25	5.0	0.55	40	3.5	0.55	62.5	3.5	0.55	125	2.5	0.55
390pF	391	25	5.0	0.55	40	3.5	0.55	62.5	3.5	0.55	125	2.5	0.55
470pF	471	25	5.0	0.55	40	3.5	0.55	62.5	3.5	0.55	125	2.5	0.55
560pF	561	25	5.0	0.55	40	3.5	0.55	62.5	3.5	0.55	125	2.5	0.55
680pF	681	25	5.0	0.55	40	3.5	0.55	62.5	3.5	0.55	125	2.5	0.55
820pF	821	25	5.0	0.55	40	3.5	0.55	62.5	3.5	0.55	125	2.5	0.55
1,000pF	102	25	5.0	0.55	40	3.5	0.55	62.5	3.5	0.55	125	2.5	0.55
1,200pF	122	25	5.0	0.55	40	3.5	0.55	62.5	3.5	0.55	125	2.5	0.55
1,500pF	152	25	5.0	0.55	40	3.5	0.55	62.5	3.5	0.55	125	2.5	0.55
1,800pF	182	25	5.0	0.55	40	3.5	0.55	62.5	3.5	0.55	125	2.5	0.55
2,200pF	222	25	5.0	0.55	40	3.5	0.55	62.5	3.5	0.55	125	2.5	0.55
2,700pF	272	25	5.0	0.55	40	3.5	0.55	62.5	3.5	0.55	125	2.5	0.55
3,300pF	332	25	5.0	0.55	40	3.5	0.55	62.5	3.5	0.55	125	2.5	0.55
3,900pF	392	25	5.0	0.55	40	3.5	0.55	62.5	3.5	0.55	125	2.5	0.55
4,700pF	472	25	5.0	0.55	40	3.5	0.55	62.5	3.5	0.55	125	2.5	0.55
5,600pF	562	25	5.0	0.55	40	3.5	0.55	62.5	3.5	0.55	125	2.5	0.55
6,800pF	682	25	5.0	0.55	40	3.5	0.55	62.5	3.5	0.55	125	2.5	0.55
8,200pF	822	25	5.0	0.55	40	3.5	0.55	62.5	3.5	0.55	125	2.5	0.55
10,000pF	103	25	5.0	0.55	40	3.5	0.55	62.5	3.5	0.55	125	2.5	0.55
15,000pF	153	25	5.0	0.55	40	3.5	0.55	62.5	3.5	0.55			
22,000pF	223	25	5.0	0.55	40	3.5	0.55	62.5	3.5	0.55			
33,000pF	333	25	5.0	0.55	40	5.0	0.55	62.5	3.5	0.55			
47,000pF	473	25	5.0	0.55	40	5.0	0.55	62.5	3.5	0.55			
68,000pF	683	25	5.0	0.55	40	5.0	0.55						
100,000pF	104	25	5.0	0.55	40	5.0	0.55						

(CONSULT FACTORY FOR CAPACITANCE VALUES NOT LISTED)

Gray shading denotes parts that are temporarily out of production

Specifications in BLACK = Production Code 3
Specifications in BLUE = Production Code 4

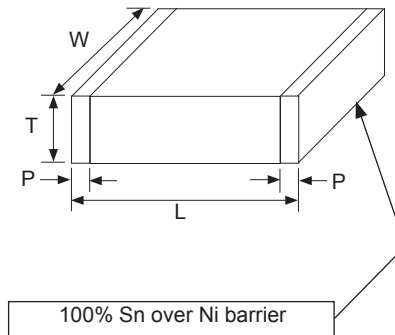

X7R STANDARD VALUES AND SPECIFICATIONS

EIA Case Size		X7R 0603 (Continued on next page)											
Length (L)		1.6 ± 0.15											
Width (W)		0.8 ± 0.15											
Termination Width (P)		0.40 ± 0.15											
Capacitance Value	Capacitance Code	Working Voltage (VDC)											
		10V			16V			25V			50V		
		DWV	DF (%)	T max. (mm)	DWV	DF (%)	T max. (mm)	DWV	DF (%)	T max. (mm)	DWV	DF (%)	T max. (mm)
100pF	101	25	5.0	0.87	40	3.5	0.87	62.5	3.5	0.87	125	2.5	0.87
120pF	121	25	5.0	0.87	40	3.5	0.87	62.5	3.5	0.87	125	2.5	0.87
150pF	151	25	5.0	0.87	40	3.5	0.87	62.5	3.5	0.87	125	2.5	0.87
180pF	181	25	5.0	0.87	40	3.5	0.87	62.5	3.5	0.87	125	2.5	0.87
220pF	221	25	5.0	0.87	40	3.5	0.87	62.5	3.5	0.87	125	2.5	0.87
270pF	271	25	5.0	0.87	40	3.5	0.87	62.5	3.5	0.87	125	2.5	0.87
330pF	331	25	5.0	0.87	40	3.5	0.87	62.5	3.5	0.87	125	2.5	0.87
390pF	391	25	5.0	0.87	40	3.5	0.87	62.5	3.5	0.87	125	2.5	0.87
470pF	471	25	5.0	0.87	40	3.5	0.87	62.5	3.5	0.87	125	2.5	0.87
560pF	561	25	5.0	0.87	40	3.5	0.87	62.5	3.5	0.87	125	2.5	0.87
680pF	681	25	5.0	0.87	40	3.5	0.87	62.5	3.5	0.87	125	2.5	0.87
820pF	821	25	5.0	0.87	40	3.5	0.87	62.5	3.5	0.87	125	2.5	0.87
1,000pF	102	25	5.0	0.87	40	3.5	0.87	62.5	3.5	0.87	125	2.5	0.87
1,200pF	122	25	5.0	0.87	40	3.5	0.87	62.5	3.5	0.87	125	2.5	0.87
1,500pF	152	25	5.0	0.87	40	3.5	0.87	62.5	3.5	0.87	125	2.5	0.87
1,800pF	182	25	5.0	0.87	40	3.5	0.87	62.5	3.5	0.87	125	2.5	0.87
2,200pF	222	25	5.0	0.87	40	3.5	0.87	62.5	3.5	0.87	125	2.5	0.87
2,700pF	272	25	5.0	0.87	40	3.5	0.87	62.5	3.5	0.87	125	2.5	0.87
3,300pF	332	25	5.0	0.87	40	3.5	0.87	62.5	3.5	0.87	125	2.5	0.87
3,900pF	392	25	5.0	0.87	40	3.5	0.87	62.5	3.5	0.87	125	2.5	0.87
4,700pF	472	25	5.0	0.87	40	3.5	0.87	62.5	3.5	0.87	125	2.5	0.87
5,600pF	562	25	5.0	0.87	40	3.5	0.87	62.5	3.5	0.87	125	2.5	0.87
6,800pF	682	25	5.0	0.87	40	3.5	0.87	62.5	3.5	0.87	125	2.5	0.87
8,200pF	822	25	5.0	0.87	40	3.5	0.87	62.5	3.5	0.87	125	2.5	0.87
0.01μF	103	25	5.0	0.87	40	3.5	0.87	62.5	3.5	0.87	125	2.5	0.87
0.012μF	123	25	5.0	0.87	40	3.5	0.87	62.5	3.5	0.87	125	2.5	0.87
0.015μF	153	25	5.0	0.87	40	3.5	0.87	62.5	3.5	0.87	125	2.5	0.87
0.018μF	183	25	5.0	0.87	40	3.5	0.87	62.5	3.5	0.87	125	2.5	0.87
0.022μF	223	25	5.0	0.87	40	3.5	0.87	62.5	3.5	0.87	125	2.5	0.87
0.027μF	273	25	5.0	0.87	40	3.5	0.87	62.5	3.5	0.87	125	2.5	0.87
0.033μF	333	25	5.0	0.87	40	3.5	0.87	62.5	3.5	0.87	125	2.5	0.95
0.039μF	393	25	5.0	0.87	40	3.5	0.87	62.5	3.5	0.87	125	2.5	0.95
0.047μF	473	25	5.0	0.87	40	3.5	0.87	62.5	3.5	0.87	125	3.0	0.95
0.056μF	563	25	5.0	0.87	40	3.5	0.87	62.5	3.5	0.87	125	3.0	0.95
0.068μF	683	25	5.0	0.87	40	3.5	0.87	62.5	3.5	0.87	125	3.0	0.95
0.082μF	823	25	5.0	0.87	40	3.5	0.87	62.5	3.5	0.87	125	3.0	0.95
0.10μF	104	25	5.0	0.87	40	3.5	0.87	62.5	3.5	0.87	125	3.0	0.95
0.15μF	154	25	5.0	0.90	40	3.5	0.90						
0.22μF	224	25	5.0	0.90	40	3.5	0.90	62.5	3.5	0.90			
0.47μF	474	25	5.0	0.90	40	5.0	0.90						

(CONSULT FACTORY FOR CAPACITANCE VALUES NOT LISTED)

Specifications in BLACK = Production Code 3
Specifications in BLUE = Production Code 4

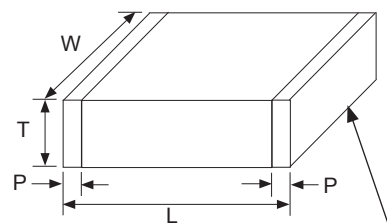

100% Sn over Ni barrier



X7R STANDARD VALUES AND SPECIFICATIONS

EIA Case Size		X7R 0603		
Length (L)		1.6 ± 0.15		
Width (W)		0.8 ± 0.15		
Termination Width(P)		0.40 ± 0.15		
Capacitance Value	Capacitance Code	Working Voltage (VDC)		
		100V		
		DWV	DF (%)	T max. (mm)
100pF	101	250	2.5	0.87
120pF	121	250	2.5	0.87
150pF	151	250	2.5	0.87
180pF	181	250	2.5	0.87
220pF	221	250	2.5	0.87
270pF	271	250	2.5	0.87
330pF	331	250	2.5	0.87
390pF	391	250	2.5	0.87
470pF	471	250	2.5	0.87
560pF	561	250	2.5	0.87
680pF	681	250	2.5	0.87
820pF	821	250	2.5	0.87
1,000pF	102	250	2.5	0.87
1,200pF	122	250	2.5	0.87
1,500pF	152	250	2.5	0.87
1,800pF	182	250	2.5	0.87
2,200pF	222	250	2.5	0.87
2,700pF	272	250	2.5	0.87
3,300pF	332	250	2.5	0.87
3,900pF	392	250	2.5	0.87
4,700pF	472	250	2.5	0.87
5,600pF	562	250	2.5	0.87
6,800pF	682	250	2.5	0.87
8,200pF	822	250	2.5	0.87
10,000pF	103	250	2.5	0.87
15,000pF	153	250	5.0	0.90
22,000pF	223	250	5.0	0.90
33,000pF	333	250	5.0	0.90
47,000pF	473	250	5.0	0.90

(CONSULT FACTORY FOR CAPACITANCE VALUES NOT LISTED)

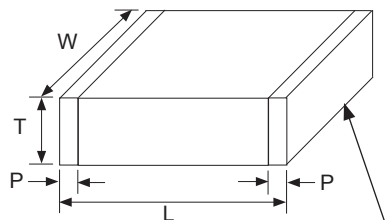

100% Sn over Ni barrier

EIA Case Size		X7R 0805 (Continued on next page)					
Length (L)		2.0 ± 0.20					
Width (W)		1.25 ± 0.20					
Termination Width(P)		0.50 ± 0.20					
Capacitance Value	Capacitance Code	Working Voltage (VDC)					
		10V			16V		
		DWV	DF (%)	T max. (mm)	DWV	DF (%)	T max. (mm)
100pF	101	25	5.0	0.9	40	3.5	0.9
120pF	121	25	5.0	0.9	40	3.5	0.9
150pF	151	25	5.0	0.9	40	3.5	0.9
180pF	181	25	5.0	0.9	40	3.5	0.9
220pF	221	25	5.0	0.9	40	3.5	0.9
270pF	271	25	5.0	0.9	40	3.5	0.9
330pF	331	25	5.0	0.9	40	3.5	0.9
390pF	391	25	5.0	0.9	40	3.5	0.9
470pF	471	25	5.0	0.9	40	3.5	0.9
560pF	561	25	5.0	0.9	40	3.5	0.9
680pF	681	25	5.0	0.9	40	3.5	0.9
820pF	821	25	5.0	0.9	40	3.5	0.9
1000pF	102	25	5.0	0.9	40	3.5	0.9
1200pF	122	25	5.0	0.9	40	3.5	0.9
1500pF	152	25	5.0	0.9	40	3.5	0.9
1800pF	182	25	5.0	0.9	40	3.5	0.9
2200pF	222	25	5.0	0.9	40	3.5	0.9
2700pF	272	25	5.0	0.9	40	3.5	0.9
3300pF	332	25	5.0	0.9	40	3.5	0.9
3900pF	392	25	5.0	0.9	40	3.5	0.9
4700pF	472	25	5.0	0.9	40	3.5	0.9
5600pF	562	25	5.0	0.9	40	3.5	0.9
6800pF	682	25	5.0	0.9	40	3.5	0.9
8200pF	822	25	5.0	0.9	40	3.5	0.9
0.01µF	103	25	5.0	0.9	40	3.5	0.9
0.012µF	123	25	5.0	0.9	40	3.5	0.9
0.015µF	153	25	5.0	0.9	40	3.5	0.9
0.018µF	183	25	5.0	0.9	40	3.5	0.9
0.022µF	223	25	5.0	0.9	40	3.5	0.9
0.027µF	273	25	5.0	0.9	40	3.5	0.9
0.033µF	333	25	5.0	0.9	40	3.5	0.9
0.039µF	393	25	5.0	0.9	40	3.5	0.9
0.047µF	473	25	5.0	0.9	40	3.5	0.9
0.056µF	563	25	5.0	0.9	40	3.5	0.9
0.068µF	683	25	5.0	0.9	40	3.5	0.9
0.082µF	823	25	5.0	0.9	40	3.5	0.9
0.1µF	104	25	5.0	0.9	40	3.5	0.9
0.12µF	124	25	5.0	0.9	40	3.5	0.9
0.15µF	154	25	5.0	1.35	40	3.5	1.35
0.18µF	184	25	5.0	1.35	40	3.5	1.35
0.22µF	224	25	5.0	1.35	40	3.5	1.35
0.27µF	274	25	5.0	1.35	40	3.5	1.35
0.33µF	334	25	5.0	1.35	40	3.5	1.35
0.39µF	394	25	5.0	1.35	40	3.5	1.35
0.47µF	474	25	5.0	1.35	40	3.5	1.35
0.56µF	564	25	5.0	1.35	40	3.5	1.35
0.68µF	684	25	5.0	1.35	40	5.0	1.35
0.82µF	824	25	5.0	1.35	40	5.0	1.35
1.0µF	105	25	5.0	1.35	40	5.0	1.35
2.2µF	225	25	5.0	1.35			

Specifications in BLACK = Production Code 3
 Specifications in BLUE = Production Code 4



X7R STANDARD VALUES AND SPECIFICATIONS

EIA Case Size		X7R 0805 (Continued on next page)											
Length (L)		2.0 ± 0.20											
Width (W)		1.25 ± 0.20											
Termination Width(P)		0.50 ± 0.20											
Capacitance Value	Capacitance Code	Working Voltage (VDC)											
		25V			50V			100V			200V		
		DWV	DF (%)	T max. (mm)	DWV	DF (%)	T max. (mm)	DWV	DF (%)	T max. (mm)	DWV	DF (%)	T max. (mm)
100pF	101	62.5	3.5	0.9	125	2.5	0.9	250	2.5	0.9	400	2.5	0.9
120pF	121	62.5	3.5	0.9	125	2.5	0.9	250	2.5	0.9	400	2.5	0.9
150pF	151	62.5	3.5	0.9	125	2.5	0.9	250	2.5	0.9	400	2.5	0.9
180pF	181	62.5	3.5	0.9	125	2.5	0.9	250	2.5	0.9	400	2.5	0.9
220pF	221	62.5	3.5	0.9	125	2.5	0.9	250	2.5	0.9	400	2.5	0.9
270pF	271	62.5	3.5	0.9	125	2.5	0.9	250	2.5	0.9	400	2.5	0.9
330pF	331	62.5	3.5	0.9	125	2.5	0.9	250	2.5	0.9	400	2.5	0.9
390pF	391	62.5	3.5	0.9	125	2.5	0.9	250	2.5	0.9	400	2.5	0.9
470pF	471	62.5	3.5	0.9	125	2.5	0.9	250	2.5	0.9	400	2.5	0.9
560pF	561	62.5	3.5	0.9	125	2.5	0.9	250	2.5	0.9	400	2.5	0.9
680pF	681	62.5	3.5	0.9	125	2.5	0.9	250	2.5	0.9	400	2.5	0.9
820pF	821	62.5	3.5	0.9	125	2.5	0.9	250	2.5	0.9	400	2.5	0.9
1000pF	102	62.5	3.5	0.9	125	2.5	0.9	250	2.5	0.9	400	2.5	0.9
1200pF	122	62.5	3.5	0.9	125	2.5	0.9	250	2.5	0.9	400	2.5	0.9
1500pF	152	62.5	3.5	0.9	125	2.5	0.9	250	2.5	0.9	400	2.5	0.9
1800pF	182	62.5	3.5	0.9	125	2.5	0.9	250	2.5	0.9	400	2.5	0.9
2200pF	222	62.5	3.5	0.9	125	2.5	0.9	250	2.5	0.9	400	2.5	0.9
2700pF	272	62.5	3.5	0.9	125	2.5	0.9	250	2.5	0.9	400	2.5	0.9
3300pF	332	62.5	3.5	0.9	125	2.5	0.9	250	2.5	0.9	400	2.5	0.9
3900pF	392	62.5	3.5	0.9	125	2.5	0.9	250	2.5	0.9	400	2.5	0.9
4700pF	472	62.5	3.5	0.9	125	2.5	0.9	250	2.5	0.9	400	2.5	0.9
5600pF	562	62.5	3.5	0.9	125	2.5	0.9	250	2.5	0.9	400	2.5	0.9
6800pF	682	62.5	3.5	0.9	125	2.5	0.9	250	2.5	0.9	400	2.5	0.9
8200pF	822	62.5	3.5	0.9	125	2.5	0.9	250	2.5	0.9	400	2.5	0.9
0.01µF	103	62.5	3.5	0.9	125	2.5	0.9	250	2.5	0.9	400	2.5	1.35
0.012µF	123	62.5	3.5	0.9	125	2.5	0.9	250	2.5	0.9	400	2.5	1.35
0.015µF	153	62.5	3.5	0.9	125	2.5	0.9	250	2.5	0.9	400	2.5	1.35
0.018µF	183	62.5	3.5	0.9	125	2.5	0.9	250	2.5	0.9	400	2.5	1.35
0.022µF	223	62.5	3.5	0.9	125	2.5	0.9	250	2.5	0.9	400	2.5	1.35
0.027µF	273	62.5	3.5	0.9	125	2.5	0.9	250	2.5	1.35			
0.033µF	333	62.5	3.5	0.9	125	2.5	0.9	250	2.5	1.35			
0.039µF	393	62.5	3.5	0.9	125	2.5	0.9	250	2.5	1.35			
0.047µF	473	62.5	3.5	0.9	125	2.5	0.9	250	2.5	1.35			
0.056µF	563	62.5	3.5	0.9	125	2.5	0.9	250	2.5	1.35			
0.068µF	683	62.5	3.5	0.9	125	2.5	0.9	250	2.5	1.35			
0.082µF	823	62.5	3.5	0.9	125	2.5	0.9	250	2.5	1.35			
0.10µF	104	62.5	3.5	0.9	125	2.5	0.9	250	5.0	1.35			
0.12µF	124	62.5	3.5	0.9	125	2.5	1.35						
0.15µF	154	62.5	3.5	1.35	125	2.5	1.35						
0.18µF	184	62.5	3.5	1.35	125	3.0	1.35						
0.22µF	224	62.5	3.5	1.35	125	3.0	1.35						
0.27µF	274	62.5	3.5	1.35									
0.33µF	334	62.5	3.5	1.35	125	3.5	1.45						
0.39µF	394	62.5	3.5	1.35									
0.47µF	474	62.5	3.5	1.35	125	3.5	1.45						
0.56µF	564	62.5	3.5	1.35									
0.68µF	684	62.5	3.5	1.35									
0.82µF	824	62.5	3.5	1.35									
1.0µF	105	62.5	5.0	1.35									

(CONSULT FACTORY FOR CAPACITANCE VALUES NOT LISTED)

Specifications in BLACK = Production Code 3
Specifications in BLUE = Production Code 4

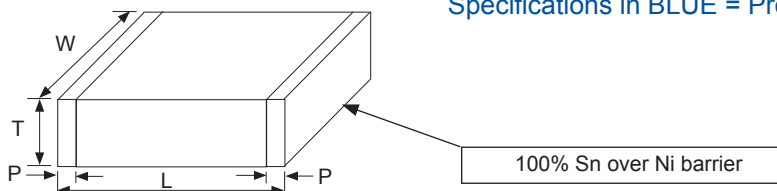

X7R STANDARD VALUES AND SPECIFICATIONS

EIA Case Size		X7R 0805								
Length (L)		2.0 ± 0.20								
Width (W)		1.25 ± 0.20								
Termination Width(P)		0.50 ± 0.20								
Capacitance Value	Capacitance Code	Working Voltage (VDC)								
		250V			500V			630V		
		DWV	DF (%)	T max. (mm)	DWV	DF (%)	T max. (mm)	DWV	DF (%)	T max. (mm)
100pF	101	500	2.5	0.9	750	2.5	0.9	945	2.5	0.9
120pF	121	500	2.5	0.9	750	2.5	0.9	945	2.5	0.9
150pF	151	500	2.5	0.9	750	2.5	0.9	945	2.5	0.9
180pF	181	500	2.5	0.9	750	2.5	0.9	945	2.5	0.9
220pF	221	500	2.5	0.9	750	2.5	0.9	945	2.5	0.9
270pF	271	500	2.5	0.9	750	2.5	0.9	945	2.5	0.9
330pF	331	500	2.5	0.9	750	2.5	0.9	945	2.5	0.9
390pF	391	500	2.5	0.9	750	2.5	0.9	945	2.5	0.9
470pF	471	500	2.5	0.9	750	2.5	0.9	945	2.5	0.9
560pF	561	500	2.5	0.9	750	2.5	0.9	945	2.5	0.9
680pF	681	500	2.5	0.9	750	2.5	0.9	945	2.5	0.9
820pF	821	500	2.5	0.9	750	2.5	0.9	945	2.5	0.9
1000pF	102	500	2.5	0.9	750	2.5	0.9	945	2.5	0.9
1200pF	122	500	2.5	0.9	750	2.5	0.9	945	2.5	0.9
1500pF	152	500	2.5	0.9	750	2.5	0.9	945	2.5	0.9
1800pF	182	500	2.5	0.9	750	2.5	0.9	945	2.5	0.9
2200pF	222	500	2.5	0.9	750	2.5	0.9	945	2.5	0.9
2700pF	272	500	2.5	0.9	750	2.5	0.9	945	2.5	0.9
3300pF	332	500	2.5	0.9	750	2.5	0.9	945	2.5	0.9
3900pF	392	500	2.5	0.9	750	2.5	0.9	945	2.5	0.9
4700pF	472	500	2.5	0.9	750	2.5	1.35	945	2.5	1.35
5600pF	562	500	2.5	0.9	750	2.5	1.35	945	2.5	1.35
6800pF	682	500	2.5	0.9	750	2.5	1.35	945	2.5	1.35
8200pF	822	500	2.5	0.9	750	2.5	1.35	945	2.5	1.35
0.01µF	103	500	2.5	1.35	750	2.5	1.35	945	2.5	1.35
0.012µF	123	500	2.5	1.35						
0.015µF	153	500	2.5	1.35						
0.018µF	183	500	2.5	1.35						
0.022µF	223	500	2.5	1.35						

(CONSULT FACTORY FOR CAPACITANCE VALUES NOT LISTED)

Specifications in BLACK = Production Code 3
 Specifications in BLUE = Production Code 4

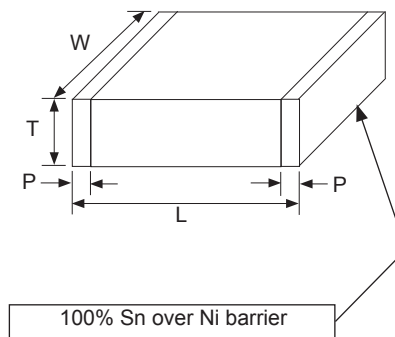

X7R STANDARD VALUES AND SPECIFICATIONS

EIA Case Size		X7R 1206 (Continued on next page)														
Length (L)		3.2 ± 0.40														
Width (W)		1.60 ± 0.30														
Termination Width(P)		0.60 ± 0.20														
Capacitance Value	Capacitance Code	Working Voltage (VDC)														
		6.3V			10V			16V			25V			50V		
		DWV	DF (%)	T max. (mm)	DWV	DF (%)	T max. (mm)	DWV	DF (%)	T max. (mm)	DWV	DF (%)	T max. (mm)	DWV	DF (%)	T max. (mm)
220pF	221				25	5	0.9	40	3.5	0.9	62.5	3.5	0.9	125	2.5	0.9
270pF	271				25	5	0.9	40	3.5	0.9	62.5	3.5	0.9	125	2.5	0.9
330pF	331				25	5	0.9	40	3.5	0.9	62.5	3.5	0.9	125	2.5	0.9
390pF	391				25	5	0.9	40	3.5	0.9	62.5	3.5	0.9	125	2.5	0.9
470pF	471				25	5	0.9	40	3.5	0.9	62.5	3.5	0.9	125	2.5	0.9
560pF	561				25	5	0.9	40	3.5	0.9	62.5	3.5	0.9	125	2.5	0.9
680pF	681				25	5	0.9	40	3.5	0.9	62.5	3.5	0.9	125	2.5	0.9
820pF	821				25	5	0.9	40	3.5	0.9	62.5	3.5	0.9	125	2.5	0.9
1000pF	102				25	5	0.9	40	3.5	0.9	62.5	3.5	0.9	125	2.5	0.9
1200pF	122				25	5	0.9	40	3.5	0.9	62.5	3.5	0.9	125	2.5	0.9
1500pF	152				25	5	0.9	40	3.5	0.9	62.5	3.5	0.9	125	2.5	0.9
1800pF	182				25	5	0.9	40	3.5	0.9	62.5	3.5	0.9	125	2.5	0.9
2200pF	222				25	5	0.9	40	3.5	0.9	62.5	3.5	0.9	125	2.5	0.9
2700pF	272				25	5	0.9	40	3.5	0.9	62.5	3.5	0.9	125	2.5	0.9
3300pF	332				25	5	0.9	40	3.5	0.9	62.5	3.5	0.9	125	2.5	0.9
3900pF	392				25	5	0.9	40	3.5	0.9	62.5	3.5	0.9	125	2.5	0.9
4700pF	472				25	5	0.9	40	3.5	0.9	62.5	3.5	0.9	125	2.5	0.9
5600pF	562				25	5	0.9	40	3.5	0.9	62.5	3.5	0.9	125	2.5	0.9
6800pF	682				25	5	0.9	40	3.5	0.9	62.5	3.5	0.9	125	2.5	0.9
8200pF	822				25	5	0.9	40	3.5	0.9	62.5	3.5	0.9	125	2.5	0.9
0.01μF	103				25	5	0.9	40	3.5	0.9	62.5	3.5	0.9	125	2.5	0.9
0.012μF	123				25	5	0.9	40	3.5	0.9	62.5	3.5	0.9	125	2.5	0.9
0.015μF	153				25	5	0.9	40	3.5	0.9	62.5	3.5	0.9	125	2.5	0.9
0.018μF	183				25	5	0.9	40	3.5	0.9	62.5	3.5	0.9	125	2.5	0.9
0.022μF	223				25	5	0.9	40	3.5	0.9	62.5	3.5	0.9	125	2.5	0.9
0.027μF	273				25	5	0.9	40	3.5	0.9	62.5	3.5	0.9	125	2.5	0.9
0.033μF	333				25	5	0.9	40	3.5	0.9	62.5	3.5	0.9	125	2.5	0.9
0.039μF	393				25	5	0.9	40	3.5	0.9	62.5	3.5	0.9	125	2.5	0.9
0.047μF	473				25	5	0.9	40	3.5	0.9	62.5	3.5	0.9	125	2.5	0.9
0.056μF	563				25	5	0.9	40	3.5	0.9	62.5	3.5	0.9	125	2.5	0.9
0.068μF	683				25	5	0.9	40	3.5	0.9	62.5	3.5	0.9	125	2.5	0.9
0.082μF	823				25	5	0.9	40	3.5	0.9	62.5	3.5	0.9	125	2.5	0.9
0.10μF	104				25	5	0.9	40	3.5	0.9	62.5	3.5	0.9	125	2.5	0.9
0.12μF	124				25	5	0.9	40	3.5	0.9	62.5	3.5	0.9	125	2.5	0.9
0.15μF	154				25	5	1.05	40	3.5	1.05	62.5	3.5	1.05	125	2.5	1.05
0.18μF	184				25	5	1.05	40	3.5	1.05	62.5	3.5	1.05	125	2.5	1.05
0.22μF	224				25	5	1.05	40	3.5	1.05	62.5	3.5	1.05	125	2.5	1.05
0.27μF	274				25	5	1.05	40	3.5	1.05	62.5	3.5	1.05	125	2.5	1.35
0.33μF	334				25	5	1.05	40	3.5	1.05	62.5	3.5	1.05	125	2.5	1.35
0.39μF	394				25	5	1.05	40	3.5	1.05	62.5	3.5	1.3	125	2.5	1.9
0.47μF	474				25	5	1.3	40	3.5	1.3	62.5	3.5	1.3	125	3.0	1.9
0.56μF	564				25	5	1.3	40	3.5	1.3	62.5	3.5	1.3	125	3.0	1.9
0.68μF	684				25	5	1.3	40	3.5	1.3	62.5	3.5	1.3	125	3.0	1.9
0.82μF	824				25	5	1.3	40	3.5	1.3	62.5	3.5	1.3	125	3.0	1.9
1.0μF	105	15.75	5.0	1.25	25	5	1.3	40	3.5	1.3	62.5	3.5	1.3	125	3.0	1.9
10μF	106	15.75	10.0	1.80												

(CONSULT FACTORY FOR CAPACITANCE VALUES NOT LISTED)

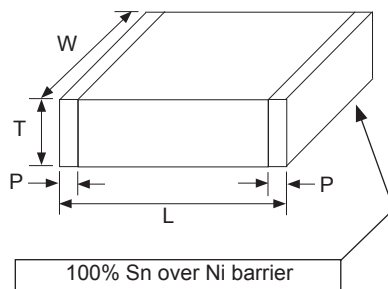

Specifications in BLACK = Production Code 3
Specifications in BLUE = Production Code 4



X7R STANDARD VALUES AND SPECIFICATIONS

EIA Case Size		X7R 1206 (Continued on next page)											
Length (L)		3.2 ± 0.40											
Width (W)		1.60 ± 0.30											
Termination Width(P)		0.60 ± 0.20											
Capacitance Value	Capacitance Code	Working Voltage (VDC)											
		100V			200V			250V			500V		
		DWV	DF (%)	T max. (mm)	DWV	DF (%)	T max. (mm)	DWV	DF (%)	T max. (mm)	DWV	DF (%)	T max. (mm)
100pF	101				400	2.5	1.9	500	2.5	1.9	750	2.5	1.9
120pF	121				400	2.5	1.9	500	2.5	1.9	750	2.5	1.9
150pF	151				400	2.5	1.9	500	2.5	1.9	750	2.5	1.9
180pF	181				400	2.5	1.9	500	2.5	1.9	750	2.5	1.9
220pF	221	250	2.5	0.9	400	2.5	1.9	500	2.5	1.9	750	2.5	1.9
270pF	271	250	2.5	0.9	400	2.5	1.9	500	2.5	1.9	750	2.5	1.9
330pF	331	250	2.5	0.9	400	2.5	1.9	500	2.5	1.9	750	2.5	1.9
390pF	391	250	2.5	0.9	400	2.5	1.9	500	2.5	1.9	750	2.5	1.9
470pF	471	250	2.5	0.9	400	2.5	1.9	500	2.5	1.9	750	2.5	1.9
560pF	561	250	2.5	0.9	400	2.5	1.9	500	2.5	1.9	750	2.5	1.9
680pF	681	250	2.5	0.9	400	2.5	1.9	500	2.5	1.9	750	2.5	1.9
820pF	821	250	2.5	0.9	400	2.5	1.9	500	2.5	1.9	750	2.5	1.9
1000pF	102	250	2.5	0.9	400	2.5	1.9	500	2.5	1.9	750	2.5	1.9
1200pF	122	250	2.5	0.9	400	2.5	1.9	500	2.5	1.9	750	2.5	1.9
1500pF	152	250	2.5	0.9	400	2.5	1.9	500	2.5	1.9	750	2.5	1.9
1800pF	182	250	2.5	0.9	400	2.5	1.9	500	2.5	1.9	750	2.5	1.9
2200pF	222	250	2.5	0.9	400	2.5	1.9	500	2.5	1.9	750	2.5	1.9
2700pF	272	250	2.5	0.9	400	2.5	1.9	500	2.5	1.9	750	2.5	1.9
3300pF	332	250	2.5	0.9	400	2.5	1.9	500	2.5	1.9	750	2.5	1.9
3900pF	392	250	2.5	0.9	400	2.5	1.9	500	2.5	1.9	750	2.5	1.9
4700pF	472	250	2.5	0.9	400	2.5	1.9	500	2.5	1.9	750	2.5	1.9
5600pF	562	250	2.5	0.9	400	2.5	1.9	500	2.5	1.9	750	2.5	1.9
6800pF	682	250	2.5	0.9	400	2.5	1.9	500	2.5	1.9	750	2.5	1.9
8200pF	822	250	2.5	0.9	400	2.5	1.9	500	2.5	1.9	750	2.5	1.9
0.01µF	103	250	2.5	0.9	400	2.5	1.9	500	2.5	1.9	750	2.5	1.9
0.012µF	123	250	2.5	0.9	400	2.5	1.9	500	2.5	1.9			
0.015µF	153	250	2.5	0.9	400	2.5	1.9	500	2.5	1.9			
0.018µF	183	250	2.5	0.9	400	2.5	1.9	500	2.5	1.9			
0.022µF	223	250	2.5	0.9	400	2.5	1.9	500	2.5	1.9			
0.027µF	273	250	2.5	0.9									
0.033µF	333	250	2.5	0.9									
0.039µF	393	250	2.5	0.9									
0.047µF	473	250	2.5	0.9									
0.056µF	563	250	2.5	0.9									
0.068µF	683	250	2.5	0.9									
0.082µF	823	250	2.5	1.35									
0.10µF	104	250	2.5	1.35									
0.12µF	124	250	2.5	1.35									
0.15µF	154	250	2.5	1.9									
0.18µF	184	250	2.5	1.9									
0.22µF	224	250	2.5	1.9									

(CONSULT FACTORY FOR CAPACITANCE VALUES NOT LISTED)

Specifications in BLACK = Production Code 3
 Specifications in BLUE = Production Code 4

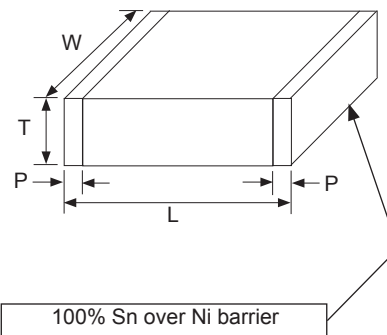

X7R STANDARD VALUES AND SPECIFICATIONS

EIA Case Size		1206		
Length (L)		3.2 ± 0.40		
Width (W)		1.60 ± 0.30		
Termination Width(P)		0.60 ± 0.20		
Capacitance Value	Capacitance Code	Working Voltage (VDC)		
		630V		
		DWV	DF (%)	T max. (mm)
100pF	101	945	2.5	1.9
120pF	121	945	2.5	1.9
150pF	151	945	2.5	1.9
180pF	181	945	2.5	1.9
220pF	221	945	2.5	1.9
270pF	271	945	2.5	1.9
330pF	331	945	2.5	1.9
390pF	391	945	2.5	1.9
470pF	471	945	2.5	1.9
560pF	561	945	2.5	1.9
680pF	681	945	2.5	1.9
820pF	821	945	2.5	1.9
1000pF	102	945	2.5	1.9
1200pF	122	945	2.5	1.9
1500pF	152	945	2.5	1.9
1800pF	182	945	2.5	1.9
2200pF	222	945	2.5	1.9
2700pF	272	945	2.5	1.9
3300pF	332	945	2.5	1.9
3900pF	392	945	2.5	1.9
4700pF	472	945	2.5	1.9
5600pF	562	945	2.5	1.9
6800pF	682	945	2.5	1.9
8200pF	822	945	2.5	1.9
0.01µF	103	945	2.5	1.9

(CONSULT FACTORY FOR CAPACITANCE VALUES NOT LISTED)

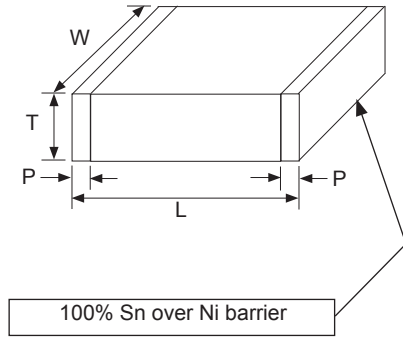

Specifications in BLACK = Production Code 3
 Specifications in BLUE = Production Code 4

EIA Case Size		X7R 1210 (Continued on next page)											
Length (L)		3.20 ±0.40											
Width (W)		2.50 ± 0.30											
Termination Width(P)		0.75 ± 0.25											
Capacitance Value	Capacitance Code	Working Voltage (VDC)											
		10V			16V			25V			50V		
		DWV	DF (%)	T max. (mm)	DWV	DF (%)	T max. (mm)	DWV	DF (%)	T max. (mm)	DWV	DF (%)	T max. (mm)
1,000pF	102	25	5.0	1.05	40	3.5	1.05	62.5	3.5	1.05	125	2.5	1.05
1,200pF	122	25	5.0	1.05	40	3.5	1.05	62.5	3.5	1.05	125	2.5	1.05
1,500pF	152	25	5.0	1.05	40	3.5	1.05	62.5	3.5	1.05	125	2.5	1.05
1,800pF	182	25	5.0	1.05	40	3.5	1.05	62.5	3.5	1.05	125	2.5	1.05
2,200pF	222	25	5.0	1.05	40	3.5	1.05	62.5	3.5	1.05	125	2.5	1.05
2,700pF	272	25	5.0	1.05	40	3.5	1.05	62.5	3.5	1.05	125	2.5	1.05
3,300pF	332	25	5.0	1.05	40	3.5	1.05	62.5	3.5	1.05	125	2.5	1.05
3,900pF	392	25	5.0	1.05	40	3.5	1.05	62.5	3.5	1.05	125	2.5	1.05
4,700pF	472	25	5.0	1.05	40	3.5	1.05	62.5	3.5	1.05	125	2.5	1.05
5,600pF	562	25	5.0	1.05	40	3.5	1.05	62.5	3.5	1.05	125	2.5	1.05
6,800pF	682	25	5.0	1.05	40	3.5	1.05	62.5	3.5	1.05	125	2.5	1.05
8,200pF	822	25	5.0	1.05	40	3.5	1.05	62.5	3.5	1.05	125	2.5	1.05
10,000pF	103	25	5.0	1.05	40	3.5	1.05	62.5	3.5	1.05	125	2.5	1.05
0.012µF	123	25	5.0	1.05	40	3.5	1.05	62.5	3.5	1.05	125	2.5	1.05
0.015µF	153	25	5.0	1.05	40	3.5	1.05	62.5	3.5	1.05	125	2.5	1.05
0.018µF	183	25	5.0	1.05	40	3.5	1.05	62.5	3.5	1.05	125	2.5	1.05
0.022µF	223	25	5.0	1.05	40	3.5	1.05	62.5	3.5	1.05	125	2.5	1.05
0.027µF	273	25	5.0	1.05	40	3.5	1.05	62.5	3.5	1.05	125	2.5	1.05
0.033µF	333	25	5.0	1.05	40	3.5	1.05	62.5	3.5	1.05	125	2.5	1.05
0.039µF	393	25	5.0	1.05	40	3.5	1.05	62.5	3.5	1.05	125	2.5	1.05
0.047µF	473	25	5.0	1.05	40	3.5	1.05	62.5	3.5	1.05	125	2.5	1.05
0.056µF	563	25	5.0	1.05	40	3.5	1.05	62.5	3.5	1.05	125	2.5	1.05
0.068µF	683	25	5.0	1.05	40	3.5	1.05	62.5	3.5	1.05	125	2.5	1.05
0.082µF	823	25	5.0	1.05	40	3.5	1.05	62.5	3.5	1.05	125	2.5	1.05
0.10µF	104	25	5.0	1.05	40	3.5	1.05	62.5	3.5	1.05	125	2.5	1.05
0.12µF	124	25	5.0	1.05	40	3.5	1.05	62.5	3.5	1.05	125	2.5	1.05
0.15µF	154	25	5.0	1.05	40	3.5	1.05	62.5	3.5	1.05	125	2.5	1.05
0.18µF	184	25	5.0	1.05	40	3.5	1.05	62.5	3.5	1.05	125	2.5	1.05
0.22µF	224	25	5.0	1.05	40	3.5	1.05	62.5	3.5	1.05	125	2.5	1.05
0.33µF	334	25	5.0	1.05	40	3.5	1.05	62.5	2.5	1.05	125	2.5	1.25
0.47µF	474	25	5.0	1.05	40	3.5	1.05	62.5	2.5	1.45	125	2.5	1.45
1.0µF	105	25	5.0	1.45	40	3.5	1.05	62.5	2.5	1.45	125	2.5	1.45
2.2µF	225				40	3.5	2.20						

(CONSULT FACTORY FOR CAPACITANCE VALUES NOT LISTED)

Specifications in BLACK = Production Code 3
 Specifications in BLUE = Production Code 4

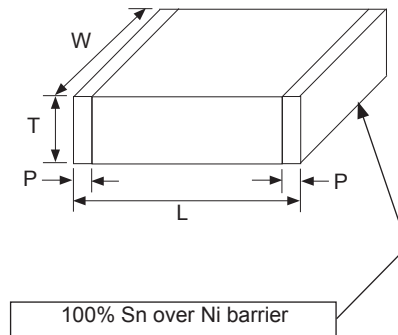

EIA Case Size		X7R 1210											
Length (L)		3.20 ± 0.40											
Width (W)		2.50 ± 0.30											
Termination Width(P)		0.75 ± 0.25											
Capacitance Value	Capacitance Code	Working Voltage (VDC)											
		100V			250V			500V			1000V		
		DWV	DF (%)	T max. (mm)	DWV	DF (%)	T max. (mm)	DWV	DF (%)	T max. (mm)	DWV	DF (%)	T max. (mm)
100pF	101				500	2.5	1.35	750	2.5	1.35	1200	2.5	1.35
120pF	121				500	2.5	1.35	750	2.5	1.35	1200	2.5	1.35
150pF	151				500	2.5	1.35	750	2.5	1.35	1200	2.5	1.35
180pF	181				500	2.5	1.35	750	2.5	1.35	1200	2.5	1.35
220pF	221				500	2.5	1.35	750	2.5	1.35	1200	2.5	1.35
270pF	271				500	2.5	1.35	750	2.5	1.35	1200	2.5	1.35
330pF	331				500	2.5	1.35	750	2.5	1.35	1200	2.5	1.35
390pF	391				500	2.5	1.35	750	2.5	1.35	1200	2.5	1.35
470pF	471				500	2.5	1.35	750	2.5	1.35	1200	2.5	1.35
560pF	561				500	2.5	1.35	750	2.5	1.35	1200	2.5	1.35
680pF	681				500	2.5	1.35	750	2.5	1.35	1200	2.5	1.35
820pF	821				500	2.5	1.35	750	2.5	1.35	1200	2.5	1.35
1,000pF	102	250	2.5	1.05	500	2.5	1.05	750	2.5	1.35	1200	2.5	1.35
1,200pF	122	250	2.5	1.05	500	2.5	1.05	750	2.5	1.35	1200	2.5	1.35
1,500pF	152	250	2.5	1.05	500	2.5	1.05	750	2.5	1.35	1200	2.5	1.35
1,800pF	182	250	2.5	1.05	500	2.5	1.05	750	2.5	1.35	1200	2.5	1.35
2,200pF	222	250	2.5	1.05	500	2.5	1.05	750	2.5	1.35	1200	2.5	1.35
2,700pF	272	250	2.5	1.05	500	2.5	1.05	750	2.5	1.35	1200	2.5	1.35
3,300pF	332	250	2.5	1.05	500	2.5	1.05	750	2.5	1.35	1200	2.5	1.35
3,900pF	392	250	2.5	1.05	500	2.5	1.05	750	2.5	1.35	1200	2.5	1.80
4,700pF	472	250	2.5	1.05	500	2.5	1.05	750	2.5	1.35	1200	2.5	1.80
5,600pF	562	250	2.5	1.05	500	2.5	1.05	750	2.5	1.35	1200	2.5	1.80
6,800pF	682	250	2.5	1.05	500	2.5	1.05	750	2.5	1.35	1200	2.5	1.80
8,200pF	822	250	2.5	1.05	500	2.5	1.05	750	2.5	1.35	1200	2.5	1.80
10,000pF	103	250	2.5	1.05	500	2.5	1.05	750	2.5	1.35	1200	2.5	1.80
0.012µF	123	250	2.5	1.05	500	2.5	1.05	750	2.5	1.35			
0.015µF	153	250	2.5	1.05	500	2.5	1.05	750	2.5	1.35			
0.018µF	183	250	2.5	1.05	500	2.5	1.05	750	2.5	1.35			
0.022µF	223	250	2.5	1.05	500	2.5	1.05	750	2.5	1.35			
0.027µF	273	250	2.5	1.05	500	2.5	1.05						
0.033µF	333	250	2.5	1.05	500	2.5	1.05						
0.039µF	393	250	2.5	1.05	500	2.5	1.05						
0.047µF	473	250	2.5	1.05	500	2.5	1.35						
0.056µF	563	250	2.5	1.05									
0.068µF	683	250	2.5	1.05									
0.082µF	823	250	2.5	1.05									
0.10µF	104	250	2.5	1.05	500	2.5	1.45						
0.22µF	224	250	2.5	1.45									

(CONSULT FACTORY FOR CAPACITANCE VALUES NOT LISTED)

Specifications in BLACK = Production Code 3
 Specifications in BLUE = Production Code 4

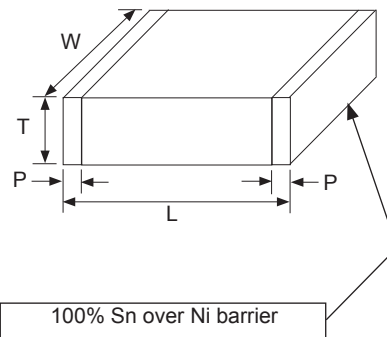

X7R STANDARD VALUES AND SPECIFICATIONS

EIA Case Size		X7R 1812					
Length (L)		4.5 ± 0.40					
Width (W)		3.2 ± 0.40					
Termination Width(P)		0.50 ± 0.25					
Capacitance Value	Capacitance Code	Working Voltage (VDC)					
		50V			100V		
		DWV	DF (%)	T max. (mm)	DWV	DF (%)	T max. (mm)
0.47µF	474	125	2.5	1.80	250	2.5	1.80
1.0µF	105	125	2.5	1.80	250	2.5	1.80

(CONSULT FACTORY FOR CAPACITANCE VALUES NOT LISTED)

Specifications in BLACK = Production Code 3
 Specifications in BLUE = Production Code 4

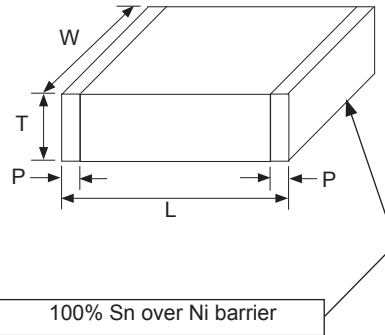

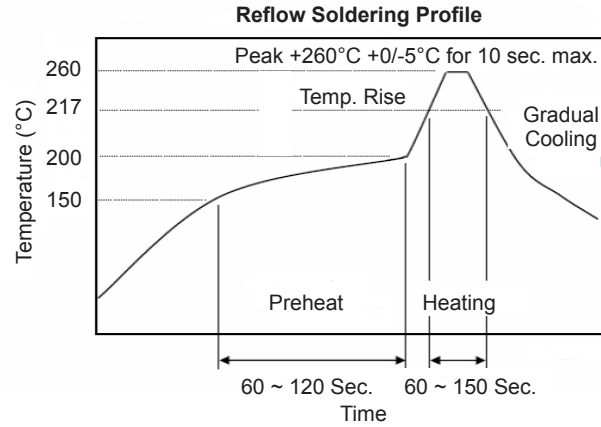

REEL QUANTITIES

Reel Size	0201	0402	0603	0805		1206				1210	1812
				T ≤ 0.90mm	T ≥ 1.0mm	T ≤ 0.90mm	T ≤ 1.35mm	T ≤ 1.80mm	T > 1.80mm	2.7mm max.	1.80 max.
7"	15K	10K	4K	4K	3K	4K	3K	2K	2K	3K	1K
13"	70K	50K	15K	15K	10K	15K	10K	10K	9K	10K	-

PUNCHED CARRIER TAPE DIMENSIONS (mm)

Type	A _o	B _o	W	F	E	P ₁	P _o	D _o	t max.
0201	0.39 ± 0.07	0.69 ± 0.07	8.0 ± 0.10	3.5 ± 0.05	1.75 ± 0.05	2.0 ± 0.05	4.0 ± 0.10	1.55 ± 0.05	0.50
0402	0.70 ± 0.20	1.20 ± 0.20				2.0 ± 0.05			0.80
0603	1.05 ± 0.30	1.80 ± 0.30				4.0 ± 0.10			1.30
0805	1.50 ± 0.20	2.30 ± 0.20							
1206	1.90 ± 0.30	3.50 ± 0.50							

0201/0402 CASE SIZE

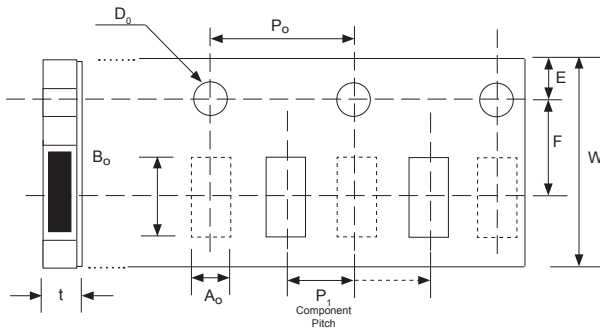

0603/0805 CASE SIZE

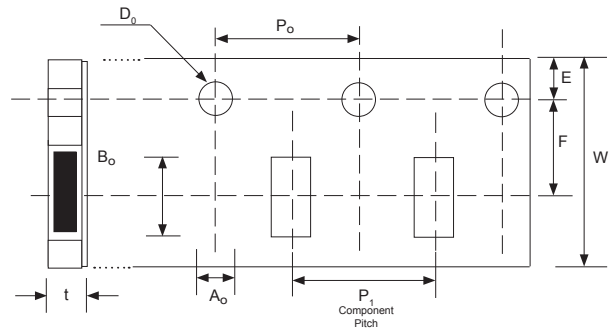

EMBOSSED PLASTIC CARRIER TAPE DIMENSIONS (mm)

Type	A _o	B _o	W	F	E	P1	P0	D0	t ₁	t ₂
0805	<1.80	<2.70	8.0 ± 0.30	3.5 ± 0.05	1.75 ± 0.10	4.0 ± 0.10	4.0 ± 0.10	1.50 +0.1/-0	0.23 ± 0.10	<2.50
1206	<2.30	<4.00								
1210	<3.05	<3.80	12.1 ± 0.20	5.5 ± 0.05	1.70 ± 0.10					
1812	<3.75	<5.20								

0805/1206/1210/1812 CASE SIZE

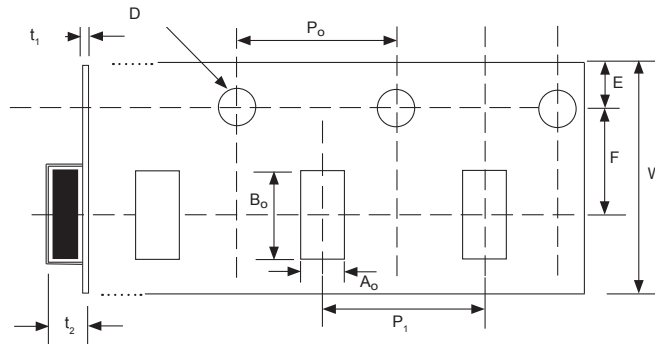

REEL

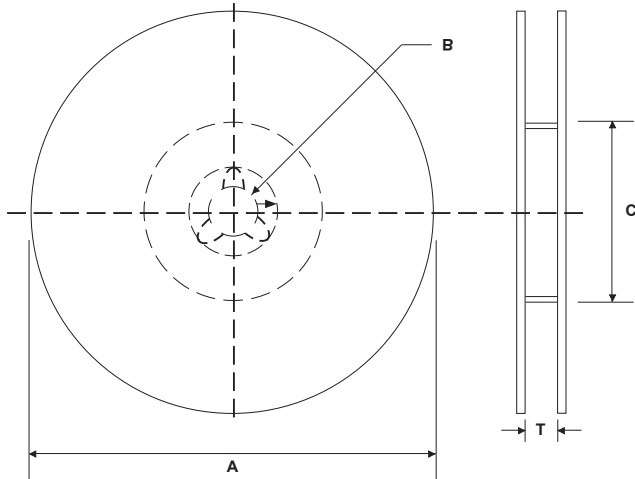

REEL DIMENSIONS (mm)

Reel Diameter (A)	B	C	T max.
7" (178 ± 0.1)	13.0 +0.5/-0.2	60.0 +1/-0	8.4 +1.5/-0
13" (330 ± 1.0)	13.0 +0.5/-0.2	100.0 ±1.0	8.4 +1.5/-0

CARRIER TAPE MATERIAL

Parts with a thickness of ≥ 1 mm will be taped on embossed plastic carrier. Parts with a thickness of less than 1mm will be taped on punched carrier

X-ON Electronics

Largest Supplier of Electrical and Electronic Components

Click to view similar products for [nic manufacturer](#):

Other Similar products are found below :

[NMC0603NPO270J100TRPF](#) [NRE-S100M25V4X7F](#) [NRE-HS102M25V12.5X16F](#) [NRCA12F1001TRQYF](#) [NRC-S06F2212TRF](#)
[NCD180J1KVNPOJTRF](#) [NRC-S06F1692TRF](#) [NCD102M1KVZ5U.250STRF](#) [NMC-P1206X7R104K100TRPF](#) [NTC-T105K20TRAF](#) [NMC-](#)
[H1206NPO471K1KVTRPLPF](#) [NML04J9N1TRF](#) [NRSNA4I4J150TR40KF](#) [NCC0805F261HTRF](#) [NRWA470M35V6.3X11TBF](#)
[NACE221M16V6.3X8TR13F](#) [NRSS332M50V18X35.5F](#) [NDTM106K25F1TRF](#) [NACZ221M50V10X10.5TR13F](#) [NCM15X7R103K50F](#)
[NRSS682M25V18X35.5F](#) [NEXC224Z5.5V10.5X8.5TRF](#) [NRLRW221M450V30X35SF](#) [NDTM225K50F2TRF](#) [NEXT105Z5.5V21.5X13F](#)
[NRSZ471M50V12.5X20F](#) [NTCL106K35TRDF](#) [NRWA331M25V10X12.5F](#) [NRSY472M25V16X31.5F](#) [NEXS105Z5.5V28.5X14F](#)
[NRLR181M400V25X30SF](#) [NRSZ102M25V12.5X20F](#) [NUVA33T385TRF](#) [NUVA33V405TRF](#) [NRLMW331M250V30X25F](#)
[NRLF103M25V35X20F](#) [NDTM106K35F](#) [NRLMW102M200V35X35F](#) [NPIS43LS220MTRF](#) [NTC-T475K50TRDF](#) [NCD222M1KVZ5UKF](#)
[NRLR472M63V25X40SF](#) [NTP157M10TRD\(40\)F](#) [NPIM74C3R3MTRF](#) [NPI104C100MTRF](#) [NRLM102M100V25X25F](#) [NRLM223M50V](#)
[35X50F](#) [NAZT221M50V10X10.5LBF](#) [NACK102M10V 10X10.5TR13F](#) [NACZ221M35V8X10.5TR13F](#)