

The documentation and process conversion measures necessary to comply with this document shall be completed by 6 August 2013.

INCH-POUND

MIL-PRF-19500/357M
6 May 2013
SUPERSEDING
MIL-PRF-19500/357L
17 July 2010

PERFORMANCE SPECIFICATION SHEET

* SEMICONDUCTOR DEVICE, TRANSISTOR, PNP, SILICON, AMPLIFIER,
TYPES 2N3634 THROUGH 2N3637, 2N3634UB THROUGH 2N3637UB, 2N3634UBN THROUGH 2N3637UBN,
2N3634L THROUGH 2N3637L, JAN, JANTX, JANTXV, JANS, JANSM, JANS, JANS, JANS, JANS, JANS, JANS, JANS,
JANS, JANS, JANSH, JANHCA, JANKCA, JANKCAM, JANKCAD, JANKCAP, JANKCAL, JANKCAR, JANKCAF,
JANKCAG, JANKCAH, JANHCB, JANKCB, JANKCBM, JANKCBD, JANKCBP, JANKCBL,
JANKCBR, JANKCBF, JANKCBG, AND JANKCBH

This specification is approved for use by all Departments and Agencies of the Department of Defense.

The requirements for acquiring the product described herein shall consist of this specification sheet and MIL-PRF-19500.

1. SCOPE

1.1 Scope. This specification covers the performance requirements for PNP, silicon, low-power amplifier, and switching transistors. Four levels of product assurance are provided for each encapsulated device type as specified in MIL-PRF-19500 and two levels of product assurance are provided for unencapsulated devices. RHA level designators "M", "D", "P", "L", "R", "F", "G", and "H" are appended to the device prefix to identify devices, which have passed RHA requirements.

* 1.2 Physical dimensions. See figure 1 (TO-5 and TO-39), figure 2 (UB and UBN), and figures 3 and 4 (JANHC and JANKC).

* 1.3 Maximum ratings. Unless otherwise specified $T_A = +25^\circ\text{C}$.

Types	$P_T (1)$ $T_A = +25^\circ\text{C}$	$P_T (2)$ $T_C = +25^\circ\text{C}$	$P_T (3)$ $T_{SP} = +25^\circ\text{C}$	$R_{\theta JA}$ (4)	$R_{\theta JC}$ (4)	$R_{\theta JSP}$ (4)	I_c	T_J and T_{STG}	V_{CBO}	V_{CEO}	V_{EBO}
	<u>W</u>	<u>W</u>	<u>W</u>	<u>°C/W</u>	<u>°C/W</u>	<u>°C/W</u>	<u>A dc</u>	<u>°C</u>	<u>V dc</u>	<u>V dc</u>	<u>V dc</u>
2N3634, 2N3634L	1	5	N/A	175	35	N/A	1	-65 to	140	140	5
2N3634UB and UBN	0.5	N/A	1.5	325	N/A	90	1	+200	140	140	5
2N3635, 2N3635L	1	5	N/A	175	35	N/A	1		140	140	5
2N3635UB and UBN	0.5	N/A	1.5	325	N/A	90	1		140	140	5
2N3636, 2N3636L	1	5	N/A	175	35	N/A	1		175	175	5
2N3636UB and UBN	0.5	N/A	1.5	325	N/A	90	1		175	175	5
2N3637, 2N3637L	1	5	N/A	175	35	N/A	1		175	175	5
2N3637UB and UBN	0.5	N/A	1.5	325	N/A	90	1		175	175	5

* (1) See figure 5 and 6.

* (2) See figure 7.

* (3) See figure 8.

* (4) See figures 9, 10, and 11.

* Comments, suggestions, or questions on this document should be addressed to DLA Land and Maritime, ATTN: VAC, P.O. Box 3990, Columbus, OH 43218-3990, or emailed to Semiconductor@dla.mil. Since contact information can change, you may want to verify the currency of this address information using the ASSIST Online database at <https://assist.dla.mil>.

MIL-PRF-19500/357M

1.4 Primary electrical characteristics. Unless otherwise specified, $T_A = +25^\circ\text{C}$.

Types	h_{FE} at $V_{CE} = 10\text{ V dc}$						$ h_{fe} $		C_{obo}	
	h_{FE1} $I_C = 0.1\text{ mA dc}$ (1)	h_{FE2} $I_C = 1.0\text{ mA dc}$ (1)	h_{FE3} $I_C = 10\text{ mA dc}$ (1)	h_{FE4} $I_C = 50\text{ mA dc}$ (1)	h_{FE5} $I_C = 150\text{ mA dc}$ (1)			$V_{CE} = 30\text{ V dc}$ $I_C = 30\text{ mA dc}$ $f = 100\text{ Mhz}$	$V_{CB} = 20\text{ V dc}$ $I_E = 0$ $100\text{ Khz} \leq f \leq 1\text{ Mhz}$	
	<u>Min</u>	<u>Min</u>	<u>Min</u>	<u>Min</u>	<u>Max</u>	<u>Min</u>	<u>Max</u>	<u>Min</u>	<u>Max</u>	<u>Max</u>
2N3634, 2N3634L	25	45	50	50	150	30		1.5	8.0	10
2N3634UB and UBN	25	45	50	50	150	30		1.5	8.0	10
2N3635, 2N3635L	55	90	100	100	300	60		2.0	8.5	10
2N3635UB and UBN	55	90	100	100	300	60		2.0	8.5	10
2N3636, 2N3636L	25	45	50	50	150	30		1.5	8.0	10
2N3636UB and UBN	25	45	50	50	150	30		1.5	8.0	10
2N3637, 2N3637L	55	90	100	100	300	60		2.0	8.5	10
2N3637UB and UBN	55	90	100	100	300	60		2.0	8.5	10

	$V_{CE(sat)1}$	$V_{CE(sat)2}$	$V_{BE(sat)1}$	$V_{BE(sat)2}$	Switching parameters			
	$I_C = 10\text{ mA dc}$ (1) $I_B = 1\text{ mA dc}$	$I_C = 50\text{ mA dc}$ (1) $I_B = 5\text{ mA dc}$	$I_C = 10\text{ mA dc}$ (1) $I_B = 1\text{ mA dc}$	$I_C = 50\text{ mA dc}$ (1) $I_B = 5\text{ mA dc}$	t_d	t_r	t_s	t_f
	<u>V dc</u>	<u>V dc</u>	<u>V dc</u>	<u>V dc</u>	<u>ns</u>	<u>ns</u>	<u>ns</u>	<u>ns</u>
Minimum				0.65				
Maximum	0.3	0.6	0.8	0.90	100	100	500	150

(1) Pulsed (see 4.5.1).

2. APPLICABLE DOCUMENTS

2.1 General. The documents listed in this section are specified in sections 3, 4, or 5 of this specification. This section does not include documents cited in other sections of this specification or recommended for additional information or as examples. While every effort has been made to ensure the completeness of this list, document users are cautioned that they must meet all specified requirements of documents cited in sections 3, 4, or 5 of this specification, whether or not they are listed.

2.2 Government documents.

2.2.1 Specifications, standards, and handbooks. The following specifications, standards, and handbooks form a part of this document to the extent specified herein. Unless otherwise specified, the issues of these documents are those cited in the solicitation or contract.

DEPARTMENT OF DEFENSE SPECIFICATIONS

MIL-PRF-19500 - Semiconductor Devices, General Specification for.

DEPARTMENT OF DEFENSE STANDARDS

MIL-STD-750 - Test Methods for Semiconductor Devices.

* (Copies of these documents are available online at <https://quicksearch.dla.mil> or <https://assist.dla.mil> or from the Standardization Document Order Desk, 700 Robbins Avenue, Building 4D, Philadelphia, PA 19111-5094.)

Ltr	Dimensions				Notes
	Inches		Millimeters		
	Min	Max	Min	Max	
CD	.305	.335	7.75	8.51	
CH	.240	.260	6.10	6.60	
HD	.335	.370	8.51	9.40	
LC	.200 TYP		5.08 TYP		7
LD	.016	.021	0.41	0.53	6
LL	See notes 7, 9, and 10				
LU	.016	.019	0.41	0.48	7
L ₁		.050		1.27	7
L ₂	.250		6.35		7
P	.100		2.54		5
Q		.050		1.27	
r		.010		0.254	8
TL	.029	.045	0.74	1.14	4
TW	.028	.034	0.71	0.86	3
α	45° TP		45° TP		6
Term 1	Emitter				
Term 2	Base				
Term 3	Collector				

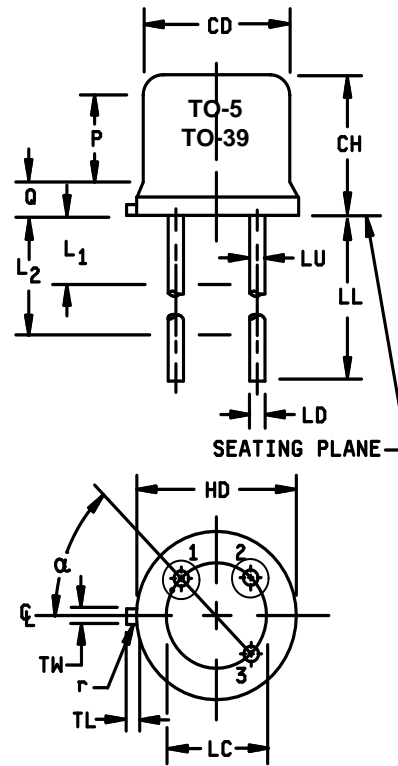

NOTES:

1. Dimensions are in inches.
2. Millimeters are given for general information only.
3. Beyond r maximum, TW must be held to a minimum length of .021 inch (0.53 mm).
4. TL measured from maximum HD.
5. CD shall not vary more than ± 0.010 inch (0.25 mm) in zone P. This zone is controlled for automatic handling.
6. Leads at gauge plane .054 - .055 inch (1.37 - 1.40 mm) below seating plane shall be within .007 inch (0.18 mm) radius of true position (TP) at a maximum material condition (MMC) relative to the tab at MMC. The device may be measured by direct methods or by gauge and gauging procedure.
7. LU applies between L₁ and L₂. LD applies between L₂ and L minimum. Diameter is uncontrolled in L₁ and beyond LL minimum.
8. r (radius) applies to both inside corners of tab.
9. For transistor types 2N3634 through 2N3637, LL is .500 inch (12.70 mm) minimum, and .750 inch (19.05 mm) maximum (TO-39).
10. For transistor types 2N3634L through 2N3637L, LL is 1.500 inches (38.10 mm) minimum, and 1.750 inches (44.45 mm) maximum (TO-5).
11. In accordance with ASME Y14.5M, diameters are equivalent to ϕx symbology.

FIGURE 1. Physical dimensions (TO-5 and TO-39).

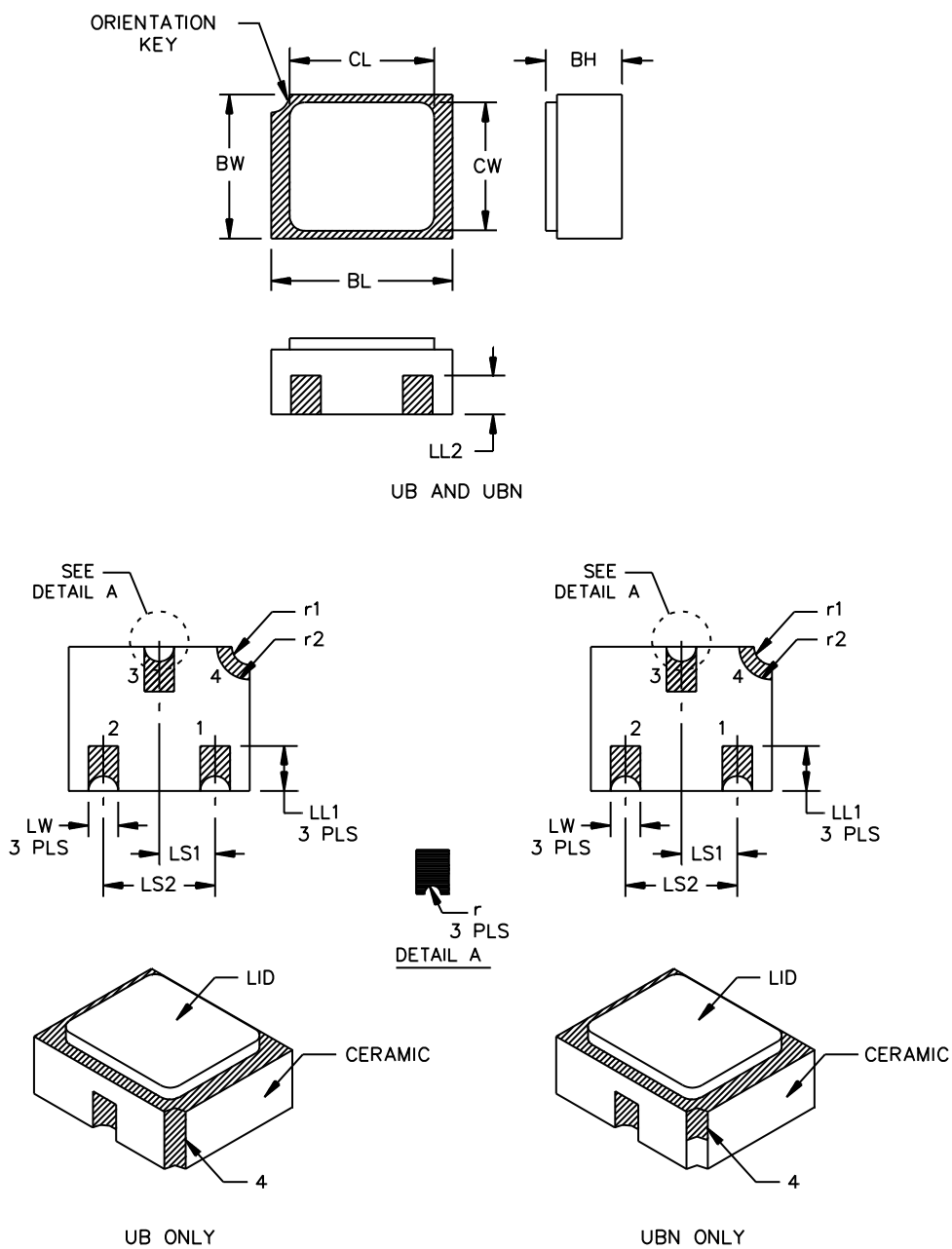

* FIGURE 2. Physical dimensions, surface mount 2N3634UB through 2N3637UB (UB and UBN version).

MIL-PRF-19500/357M

Symbol	Dimensions				Note
	Inches		Millimeters		
	Min	Max	Min	Max	
BH	.046	.056	1.17	1.42	
BL	.115	.128	2.92	3.25	
BW	.085	.108	2.16	2.74	
CL		.128		3.25	
CW		.108		2.74	
LL1	.022	.038	0.56	0.97	
LL2	.017	.035	0.43	0.89	

Symbol	Dimensions				Note
	Inches		Millimeters		
	Min	Max	Min	Max	
LS ₁	.036	.040	0.91	1.02	
LS ₂	.071	.079	1.80	2.01	
LW	.016	.024	0.41	0.61	
r		.008		.203	
r1		.012		.305	
r2		.022		.559	

NOTES:

1. Dimensions are in inches.
2. Millimeters are given for general information only.
3. Hatched areas on package denote metallized areas.
4. Lid material: Kovar.
5. UB only: Pad 1 = Base, Pad 2 = Emitter, Pad 3 = Collector, Pad 4 = Shielding connected to the metal lid.
6. UBN only: Pad 1 = Base, Pad 2 = Emitter, Pad 3 = Collector, Isolated lid with three pads only.
7. In accordance with ASME Y14.5M, diameters are equivalent to ϕ x symbology.

* FIGURE 2. Physical dimensions, surface mount 2N3634UB through 2N3637UB (UB and UBN version).

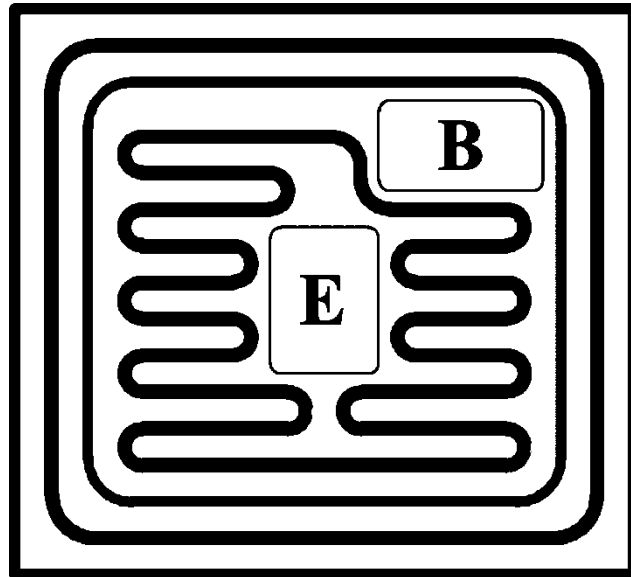

1. Chip size.....024 x .026 inch \pm .002 inch (0.61 x 0.66 mm \pm 0.051mm).
2. Chip thickness.....010 \pm .0015 inch nominal (0.254 \pm 0.038 mm).
3. Top metal.....Aluminum 15,000Å minimum, 18,000Å nominal.
4. Back metal.....Gold 3,500Å minimum, 5,000Å nominal.
5. Backside.....Collector.
6. Bonding padB = .004 x .006 inch, (0.102 mm x 0.152 mm).
E = .004 x .0055 inch. (0.102 mm x 0.140 mm).
- * 7. In accordance with ASME Y14.5M, diameters are equivalent to ϕ x symbology.

* FIGURE 3. JANHCA and JANKCA die dimensions.

MIL-PRF-19500/357M

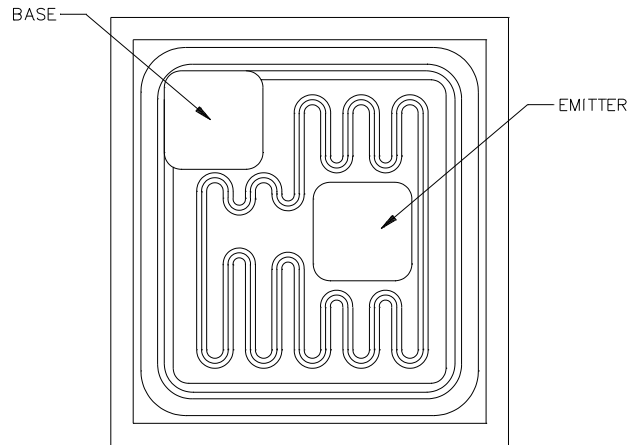

1. Chip size.....024 x .0259 inch nominal (0.61 x 0.66 mm).
 2. Chip thickness.....0079 inch nominal (0.21mm).
 3. Top metal.....Aluminum 20,000Å nominal.
 4. Back metal.....12K Gold.
 5. Backside.Collector.
- * 6. In accordance with ASME Y14.5M, diameters are equivalent to ϕ x symbology.

* FIGURE 4. JANHCB and JANKCB die dimensions.

2.3 Order of precedence Unless otherwise noted herein or in the contract, in the event of a conflict between the text of this document and the references cited herein, the text of this document takes precedence. Nothing in this document, however, supersedes applicable laws and regulations unless a specific exemption has been obtained.

3. REQUIREMENTS

3.1 General. The individual item requirements shall be as specified in MIL-PRF-19500 and as modified herein.

3.2 Qualification. Devices furnished under this specification shall be products that are manufactured by a manufacturer authorized by the qualifying activity for listing on the applicable qualified manufacturers list before contract award (see 4.2 and 6.3).

3.3 Abbreviations, symbols, and definitions. Abbreviations, symbols, and definitions used herein shall be as specified in MIL-PRF-19500 and as follows.

- $R_{\theta JSP(AM)}$ Thermal resistance junction to solder pads (adhesive mount to PCB).
- $R_{\theta JSP(IS)}$ Thermal resistance junction to solder pads (infinite sink mount to PCB).

3.4 Interface and physical dimensions. Interface and physical dimensions shall be as specified in MIL-PRF-19500, and figure 1, 2, and 3 herein.

3.4.1 Lead finish. Lead finish shall be solderable in accordance with MIL-PRF-19500, MIL-STD-750, and herein. Where a choice of lead finish is desired, it shall be specified in the acquisition document (see 6.2).

3.5 Radiation hardness assurance (RHA). Radiation hardness assurance requirements, PIN designators, and test levels shall be as defined in MIL-PRF-19500.

3.6 Electrical performance characteristics. Unless otherwise specified herein, the electrical performance characteristics are as specified in 1.3, 1.4, and table I.

3.7 Electrical test requirements. The electrical test requirements shall be as specified in table I herein.

3.8 Marking. Marking shall be in accordance with MIL-PRF-19500. The radiation hardened designator M, D, P, L, R, F, G, or H shall immediately precede (or replace) the device "2N" identifier (depending upon degree of abbreviation required).

3.9 Workmanship. Semiconductor devices shall be processed in such a manner as to be uniform in quality and shall be free from other defects that will affect life, serviceability, or appearance.

4. VERIFICATION

4.1 Classification of inspections. The inspection requirements specified herein are classified as follows:

- a. Qualification inspection (see 4.2).
- b. Screening (see 4.3).
- c. Conformance inspection (see 4.4 and tables I and II).

4.2 Qualification inspection. Qualification inspection shall be in accordance with MIL-PRF-19500 and as specified herein.

4.2.1 JANHC and JANKC qualification. JANHC and JANKC qualification inspection shall be in accordance with MIL-PRF-19500.

4.2.2 Group E qualification. Group E inspection shall be performed for qualification or requalification only. In case qualification was awarded to a prior revision of the specification sheet that did not request the performance of [table III](#) tests, the tests specified in [table III](#) herein that were not performed in the prior revision shall be performed on the first inspection lot to this revision to maintain qualification.

4.3 Screening (JANTX, JANTXV, and JANS levels only). Screening shall be in accordance with table E-IV of MIL-PRF-19500, and as specified herein. The following measurements shall be made in accordance with [table I](#) herein. Devices that exceed the limits of [table I](#) herein shall not be acceptable.

Screen (see table E-IV of MIL-PRF-19500)	Measurement	
	JANS level	JANTX and JANTXV levels
(1) 3c	Thermal impedance, method 3131 of MIL-STD-750 (see 4.3.3).	Thermal impedance, method 3131 of MIL-STD-750 (see 4.3.3).
9	I_{CBO2} and h_{FE5}	Not applicable
10	24 hours minimum.	24 hours minimum.
11	I_{CBO2} and h_{FE5} ΔI_{CBO2} = 100 percent of initial value or 10 nA dc, whichever is greater; Δh_{FE5} = ± 15 percent of initial value.	I_{CBO2} and h_{FE5}
12	See 4.3.2 , 240 hours minimum.	See 4.3.2 .
13	Subgroups 2 and 3 of table I herein; ΔI_{CBO2} = 100 percent of initial value or 10 nA dc, whichever is greater. Δh_{FE5} = ± 15 percent of initial value.	Subgroup 2 of table I herein; ΔI_{CBO2} = 100 percent of initial value or 10 nA dc, whichever is greater. Δh_{FE5} = ± 15 percent of initial value.

(1) Shall be performed anytime after temperature cycling, screen 3a; JANTX and JANTXV levels do not need to be repeated in screening requirements.

4.3.1 Screening (JANHNC and JANKC). Screening of JANHNC and JANKC die shall be in accordance with MIL-PRF-19500; "Discrete Semiconductor Die/Chip Lot Acceptance". Burn-in duration for the JANKC level follows JANS requirements; the JANHNC follows JANTX requirements.

4.3.2 Power burn-in conditions. Power burn-in conditions are as follows: $V_{CB} = 10 - 30$ V dc. Power shall be applied to achieve $T_J = +135^\circ\text{C}$ minimum using a minimum $P_D = 75$ percent of P_T maximum rated as defined in [1.3](#). With approval of the qualifying activity and preparing activity, alternate burn-in criteria (hours, bias conditions, T_J , and mounting conditions) may be used for JANTX and JANTXV quality levels. A justification demonstrating equivalence is required. In addition, the manufacturing site's burn-in data and performance history will be essential criteria for burn-in modification approval.

* 4.3.3 Thermal impedance ($Z_{\theta JX}$ measurements). The $Z_{\theta JX}$ measurements shall be performed in accordance with method 3131 of MIL-STD-750 using the guidelines in that method for determining I_M , I_H , t_H , t_{MD} (and V_C where appropriate). (See figures 9 through 11.) Measurement delay time (t_{MD}) = 70 μs maximum. See [table III](#), group E, subgroup 4 herein.

MIL-PRF-19500/357M

4.4 Conformance inspection. Conformance inspection shall be in accordance with MIL-PRF-19500 and as specified herein. If alternate screening is being performed in accordance with MIL-PRF-19500, a sample of screened devices shall be submitted to and pass the requirements of [table I](#), group A, subgroup 1, subgroup 2 inspection only.

4.4.1 Group A inspection. Group A inspection shall be conducted in accordance with table E-V of MIL-PRF-19500 and [table I](#) herein.

4.4.2 Group B inspection. Group B inspection shall be conducted in accordance with the conditions specified for subgroup testing in table E-VIa (JANS) of MIL-PRF-19500 and [4.4.2.1](#) herein. Electrical measurements (end-points) and delta requirements shall be in accordance with [table I](#), group A, subgroup 2 and [4.5.4](#) herein. See [4.4.2.2](#) for JAN, JANTX, and JANTXV group B testing. Electrical measurements (end-points) and delta requirements for JAN, JANTX, and JANTXV shall be after each step in [4.4.2.2](#) and shall be in accordance with [table I](#), group A, subgroup 2 and [4.5.4](#) herein.

4.4.2.1 Group B inspection, table E-VIa (JANS) of MIL-PRF-19500.

<u>Subgroup</u>	<u>Method</u>	<u>Condition</u>
-----------------	---------------	------------------

B4	1037	$V_{CB} = 10 - 30$ V dc; 2,000 cycles. No heat sink or forced-air cooling on devices shall be permitted.
----	------	--

B5	1027	$V_{CB} = 10$ V dc; $P_D \geq 100$ percent of maximum rated P_T (see 1.3). (NOTE: If a failure occurs, resubmission shall be at the test conditions of the original sample.)
----	------	---

Option 1: 96 hours minimum, sample size in accordance with table E-VIa of MIL-PRF-19500 adjust T_A or P_D to achieve $T_J = +275^\circ\text{C}$ minimum.

Option 2: 216 hours minimum, sample size = 45, $c = 0$; adjust T_A or P_D to achieve $T_J = +225^\circ\text{C}$ minimum.

4.4.2.2 Group B inspection, table E-VIb (JAN, JANTX, and JANTXV) of MIL-PRF-19500. Separate samples may be used for each step. In the event of a lot failure, the resubmission requirements of MIL-PRF-19500 shall apply. In addition, all catastrophic failures during CI shall be analyzed to the extent possible to identify root cause and corrective action. Whenever a failure is identified as wafer lot and /or wafer processing related, the entire wafer lot and related devices assembled from the wafer lot shall be rejected unless an appropriate determined corrective action to eliminate the failures mode has been implemented and the devices from the wafer lot are screened to eliminate the failure mode.

<u>Step</u>	<u>Method</u>	<u>Condition</u>
-------------	---------------	------------------

1	1026	Steady-state life: 1,000 hours minimum, $V_{CB} = 10$ V dc, power shall be applied to achieve $T_J = +150^\circ\text{C}$ minimum using a minimum of $P_D = 75$ percent of maximum rated P_T as defined in 1.3 . $n = 45$ devices, $c = 0$. The sample size may be increased and the test time decreased as long as the devices are stressed for a total of 45,000 device hours minimum, and the actual time of test is at least 340 hours.
---	------	---

2	1048	Blocking life, $T_A = +150^\circ\text{C}$, $V_{CB} = 80$ percent of rated voltage, 48 hours minimum. $n = 45$ devices, $c = 0$.
---	------	---

3	1032	High-temperature life (non-operating), $t = 340$ hours, $T_A = +200^\circ\text{C}$. $n = 22$, $c = 0$.
---	------	---

4.4.2.3 Group B sample selection. Samples selected from group B inspection shall meet all of the following requirements:

- a. For JAN, JANTX, and JANTXV samples shall be selected randomly from a minimum of three wafers (or from each wafer in the lot) from each wafer lot. For JANS, samples shall be selected from each inspection lot. See MIL-PRF-19500.
- b. Shall be chosen from an inspection lot that has been submitted to and passed [table I](#), subgroup 2, conformance inspection. When the final lead finish is solder or any plating prone to oxidation at high temperature, the samples for life test (subgroups B4 and B5 for JANS, and group B for JAN, JANTX, and JANTXV) may be pulled prior to the application of final lead finish.

4.4.3 Group C inspection. Group C inspection shall be conducted in accordance with the test and conditions specified for subgroup testing in table E-VII of MIL-PRF-19500, and in [4.4.3.1](#) (JANS) and [4.4.3.2](#) (JAN, JANTX, and JANTXV) herein for group C testing. Electrical measurements (end-points) requirements shall be in accordance with subgroup 2, of [table I](#) and [4.5.4](#) herein; delta requirements only apply to subgroup C6.

4.4.3.1 Group C inspection (JANS), table E-VII of MIL-PRF-19500.

<u>Subgroup</u>	<u>Method</u>	<u>Condition</u>
C2	2036	Test condition E; (not applicable for UB and UBN devices).
C5	3131	$R_{\theta JA}$ and $R_{\theta JC}$ only, as applicable (see 1.3) and in accordance with thermal impedance curves.
C6	1026	Test condition B, 1,000 hours at $V_{CB} = 10$ V dc; power shall be applied to achieve $T_J = +150^\circ\text{C}$ minimum and a minimum of $P_D = 75$ percent of maximum rated P_T as defined in 1.3 . $n = 45$, $c = 0$. The sample size may be increased and the test time decreased as long as the devices are stressed for a total of 45,000 device hours minimum, and the actual time of test is at least 340 hours.

4.4.3.2 Group C inspection (JAN, JANTX, and JANTXV), table E-VII of MIL-PRF-19500.

<u>Subgroup</u>	<u>Method</u>	<u>Condition</u>
C2	2036	Test condition E; not applicable for UB and UBN devices.
C5	3131	$R_{\theta JA}$ and $R_{\theta JC}$ only, (see 1.3 and 4.3.3) and in accordance with thermal impedance curves.
C6		Not applicable.

4.4.3.3 Group C sample selection. Samples for subgroups in group C shall be chosen at random from any inspection lot containing the intended package type and lead finish procured to the same specification which is submitted to and passes [table I](#) tests herein for conformance inspection. When the final lead finish is solder or any plating prone to oxidation at high temperature, the samples for C6 life test may be pulled prior to the application of final lead finish. Testing of a subgroup using a single device type enclosed in the intended package type shall be considered as complying with the requirements for that subgroup.

4.4.4 Group D inspection. Conformance inspection for hardness assured JANS and JANTXV types shall include the group D tests specified in [table II](#) herein. These tests shall be performed as required in accordance with MIL-PRF-19500 and method 1019 of MIL-STD-750, for total ionizing dose or method 1017 of MIL-STD-750 for neutron fluence as applicable (see [6.2](#) herein), except group D, subgroup 2 may be performed separate from other subgroups. Alternate package options may also be substituted for the testing provided there is no adverse effect to the fluence profile.

MIL-PRF-19500/357M

4.4.5 Group E inspection. Group E inspection shall be conducted in accordance with the conditions specified for subgroup testing in appendix E, table E-IX of MIL-PRF-19500 and as specified herein. Electrical measurements (end-points) shall be in accordance with subgroup 2 of [table I](#) and [4.5.4](#) herein.

4.5 Method of inspection. Methods of inspection shall be as specified in the appropriate tables and as follows.

4.5.1 Pulse measurements. Conditions for pulse measurement shall be as specified in section 4 of MIL-STD-750.

4.5.2 Input capacitance. This test shall be conducted in accordance with method 3240 of MIL-STD-750, except the output capacitor shall be omitted.

4.5.3 Noise figure. Noise figure shall be measured using a model 310B Quan Tech Laboratories test set, or equivalent. Conditions shall be as specified in [table I](#) herein.

4.5.4 Delta requirements. Delta requirements shall be as specified below:

Step	Inspection	MIL-STD-750		Symbol	Limit	Unit
		Method	Conditions			
1	Collector-base cutoff current	3036	Bias condition D, $V_{CB} = 100 \text{ V dc}$	ΔI_{CB02} (1)	100 percent of initial value or $\pm 20 \text{ nA dc}$, whichever is greater.	
2	Forward current transfer ratio	3076	$V_{CE} = 10 \text{ V dc}$; $I_C = 150 \text{ mA dc}$; pulsed see 4.5.1	Δh_{FE5} (1)	± 25 percent change from initial reading.	

(1) Devices which exceed the [table I](#) limits for this test shall not be accepted.

MIL-PRF-19500/357M

* TABLE I. Group A inspection.

Inspection <u>1/</u>	MIL-STD-750		Symbol	Limits		Unit
	Method	Conditions		Min	Max	
<u>Subgroup 1 2/</u>						
Visual and mechanical inspection <u>3/</u>	2071					
Solderability <u>3/ 4/</u>	2026	n = 15 leads, c = 0				
Resistance to solvents <u>3/ 4/ 5/</u>	1022	n = 15 devices, c = 0				
Temp cycling <u>3/ 4/</u>	1051	Test condition C, 25 cycles. n = 22 devices, c = 0				
Hermetic seal <u>4/</u> Fine leak Gross leak	1071	n = 22 devices, c = 0				
Electrical measurements <u>4/</u>		Table I , subgroup 2				
Decap internal visual (design verification)	2075	n = 4 device, c = 0				
<u>Subgroup 2</u>						
Thermal impedance	3131	See 4.3.3 .	$Z_{\theta JX}$			°C/W
Collector to base, cutoff current	3036	Bias condition D				
2N3634, 2N3634L, UB, UBN		$V_{CB} = 140$ V dc	I_{CBO1}	10		μA dc
2N3635, 2N3635L, UB, UBN		$V_{CB} = 140$ V dc	I_{CBO1}	10		μA dc
2N3636, 2N3636L, UB, UBN		$V_{CB} = 175$ V dc	I_{CBO1}	10		μA dc
2N3637, 2N3637L, UB, UBN		$V_{CB} = 175$ V dc	I_{CBO1}	10		μA dc
Emitter to base, cutoff current	3061	Bias condition D, $V_{EB} = 5$ V dc	I_{EBO1}	10		μA dc
Breakdown voltage, collector to emitter	3011	Bias condition D, $I_C = 10$ mA dc pulsed (see 4.5.1)	$V_{(BR)CEO}$			
2N3634, 2N3634L, UB, UBN 2N3635, 2N3635L, UB, UBN				140		V dc
2N3636, 2N3636L, UB, UBN 2N3637, 2N3637L, UB, UBN				175		V dc

See footnotes at end of table.

MIL-PRF-19500/357M

* TABLE I. Group A inspection - Continued.

Inspection <u>1/</u>	MIL-STD-750		Symbol	Limits		Unit
	Method	Conditions		Min	Max	
<u>Subgroup 2</u> - Continued						
Collector to base cutoff current	3036	Bias condition D, $V_{CB} = 100$ V dc	I_{CBO2}	100		nA dc
Emitter to base cutoff current	3061	Bias condition D, $V_{EB} = 3$ V dc	I_{EBO2}	50		nA dc
Collector to emitter cutoff current	3041	Bias condition D, $V_{CE} = 100$ V dc	I_{CEO}	10		μ A dc
Forward-current transfer ratio 2N3634, 2N3634L, UB, UBN 2N3635, 2N3635L, UB, UBN	3076	$V_{CE} = 10$ V dc, $I_C = 0.1$ mA dc pulsed (see 4.5.1)	h_{FE1}	25		
2N3636, 2N3636L, UB, UBN 2N3637, 2N3637L, UB, UBN				55		
Forward-current transfer ratio 2N3634, 2N3634L, UB, UBN 2N3635, 2N3635L, UB, UBN	3076	$V_{CE} = 10$ V dc, $I_C = 1.0$ mA dc pulsed (see 4.5.1)	h_{FE2}	45		
2N3636, 2N3636L, UB, UBN 2N3637, 2N3637L, UB, UBN				90		
Forward-current transfer ratio 2N3634, 2N3634L, UB, UBN 2N3635, 2N3635L, UB, UBN	3076	$V_{CE} = 10$ V dc, $I_C = 10$ mA dc pulsed (see 4.5.1)	h_{FE3}	50		
2N3636, 2N3636L, UB, UBN 2N3637, 2N3637L, UB, UBN				100		
Forward-current transfer ratio 2N3634, 2N3634L, UB, UBN 2N3635, 2N3635L, UB, UBN	3076	$V_{CE} = 10$ V dc, $I_C = 50$ mA dc pulsed (see 4.5.1)	h_{FE4}	50	150	
2N3636, 2N3636L, UB, UBN 2N3637, 2N3637L, UB, UBN				100	300	
Forward-current transfer ratio 2N3634, 2N3634L, UB, UBN 2N3635, 2N3635L, UB, UBN	3076	$V_{CE} = 10$ V dc, $I_C = 150$ mA dc pulsed (see 4.5.1)	h_{FE5}	30		
2N3636, 2N3636L, UB, UBN 2N3637, 2N3637L, UB, UBN				60		

See footnotes at end of table.

MIL-PRF-19500/357M

* TABLE I. Group A inspection - Continued.

Inspection <u>1</u> /	MIL-STD-750		Symbol	Limits		Unit
	Method	Conditions		Min	Max	
<u>Subgroup 2</u> - Continued						
Collector to emitter voltage (saturated)	3071	$I_C = 10 \text{ mA dc}$, $I_B = 1 \text{ mA dc}$ pulsed (see 4.5.1)	$V_{CE(sat)1}$	0.3		V dc
Collector to emitter voltage (saturated)	3071	$I_C = 50 \text{ mA dc}$, $I_B = 5 \text{ mA dc}$ pulsed (see 4.5.1)	$V_{CE(sat)2}$	0.6		V dc
Base-emitter voltage (saturated)	3066	Test condition A; $I_C = 10 \text{ mA dc}$, $I_B = 1.0 \text{ mA dc}$ pulsed (see 4.5.1)	$V_{BE(sat)1}$	0.8		V dc
Base-emitter voltage (saturated)	3066	Test condition A; $I_C = 50 \text{ mA dc}$, $I_B = 5 \text{ mA dc}$ pulsed (see 4.5.1)	$V_{BE(sat)2}$	0.65	0.90	V dc
<u>Subgroup 3</u>						
High temperature operation:		$T_A = +150^\circ\text{C}$				
Collector to base cutoff current	3036	Bias condition D, $V_{CB} = -100 \text{ V dc}$	I_{CBO3}	10		$\mu\text{A dc}$
Low-temperature operation:		$T_A = -55^\circ\text{C}$				
Forward-current transfer ratio	3076	$V_{CE} = 10 \text{ V dc}$, $I_C = 50 \text{ mA dc}$	h_{FE6}	25		
2N3634, 2N3634L, UB, UBN 2N3635, 2N3635L, UB, UBN				50		
2N3636, 2N3636L, UB, UBN 2N3637, 2N3637L, UB, UBN						
<u>Subgroup 4</u>						
Small-signal short-circuit forward-current transfer ratio	3306	$V_{CE} = 30 \text{ V dc}$, $I_C = 30 \text{ mA dc}$, $f = 100 \text{ MHz}$	$ h_{fe} $	1.5	8.0	
2N3634, 2N3634L, UB, UBN 2N3635, 2N3635L, UB, UBN				2.0	8.5	
2N3636, 2N3636L, UB, UBN 2N3637, 2N3637L, UB, UBN						
Small-signal short-circuit forward current transfer ratio	3206	$V_{CE} = 10 \text{ V dc}$, $I_C = 10 \text{ mA dc}$, $f = 1 \text{ kHz}$	h_{fe}	40	160	
2N3634, 2N3634L, UB, UBN 2N3635, 2N3635L, UB, UBN				80	320	
2N3636, 2N3636L, UB, UBN 2N3637, 2N3637L, UB, UBN						

See footnotes at end of table.

MIL-PRF-19500/357M

* TABLE I. Group A inspection - Continued.

Inspection <u>1</u> /	MIL-STD-750		Symbol	Limits		Unit
	Method	Conditions		Min	Max	
<u>Subgroup 4</u> - Continued						
Small-signal short-circuit input impedance	3201	$V_{CE} = 10 \text{ V dc}$, $I_C = 10 \text{ mA dc}$, $f = 1 \text{ kHz}$	h_{ie}	100	600	Ω
2N3634, 2N3634L, UB, UBN 2N3636, 2N3636L, UB, UBN						
2N3635, 2N3635L, UB, UBN 2N3637, 2N3637L, UB, UBN				200	1,200	Ω
Small signal open circuit reverse voltage transfer ratio	3211	$V_{CE} = 10 \text{ V dc}$, $I_C = 10 \text{ mA dc}$, $f = 1 \text{ kHz}$	h_{re}		3×10^{-4}	
Small signal open circuit output admittance	3216	$V_{CE} = 10 \text{ V dc}$, $I_C = 10 \text{ mA dc}$, $f = 1 \text{ kHz}$	h_{oe}		200	μs
Open circuit output capacitance	3236	$V_{CB} = 20 \text{ V dc}$, $I_E = 0$, $100 \text{ kHz} \leq f \leq 1 \text{ MHz}$	C_{obo}		10	pF
Input capacitance (output open circuited)	3240	$V_{EB} = 1 \text{ V dc}$, $I_C = 0$, $100 \text{ kHz} \leq f \leq 1 \text{ MHz}$	C_{ibo}		75	pF
Noise figure	3246	$V_{CE} = 10 \text{ V dc}$, $I_C = 0.5 \text{ mA dc}$, $R_G = 1 \text{ k}\Omega$ (see 4.5.3) $f = 100 \text{ Hz}$ $f = 10 \text{ kHz}$ $f = 1 \text{ kHz}$	NF		5 3 3	dB dB dB
Pulse response	3251	Test condition A				
Switching parameters						
Pulse delay time		See figure 12	t_d		100	ns
Pulse rise time		See figure 12	t_r		100	ns
Pulse storage time		See figure 12	t_s		500	ns
Pulse fall time		See figure 12	t_f		150	ns
t_{off}		t_s & t_f	t_{off}		600	ns

See footnotes at end of table.

MIL-PRF-19500/357M

* TABLE I. Group A inspection - Continued.

Inspection <u>1</u> /	MIL-STD-750		Symbol	Limits		Unit
	Method	Conditions		Min	Max	
<u>Subgroup 5</u> Safe operating area (continuous dc) TO-39 <u>Test 1</u> 2N3634, 2N3634L 2N3635, 2N3635L 2N3636, 2N3636L 2N3637, 2N3637L <u>Test 2</u> <u>Test 3</u>	3051	$T_C = + 25^\circ\text{C}$, $t = 1\text{s}$, 1 cycle (see figures 13 and 14) $V_{CE} = 100\text{ V dc}$, $I_C = 30\text{ mA dc}$ $V_{CE} = 130\text{ V dc}$, $I_C = 20\text{ mA dc}$				
Safe operating area (continuous dc) UB <u>Test 1</u> 2N3634UB, 2N3635UB, 2N3634UBN, 2N3635UBN 2N3636UB, 2N3637UB 2N3636UBN, 2N3637UBN <u>Test 2</u> <u>Test 3</u> End-point electrical measurements <u>Subgroups 6 and 7</u> Not applicable	3051	$T_C = + 25^\circ\text{C}$, $t = 100\text{ ms}$, 1 cycle (see figures 15 and 16) $V_{CE} = 85\text{ V dc}$, $I_C = 30\text{ mA dc}$ $V_{CE} = 125\text{ V dc}$, $I_C = 20\text{ mA dc}$ $V_{CE} = 50\text{ V dc}$, $I_C = 50\text{ mA dc}$ $V_{CE} = 5\text{ V dc}$, $I_C = 500\text{ mA dc}$ Subgroup 2 of table I .				

1/ For sampling plan see MIL-PRF-19500.

2/ For resubmission of failed [table I](#), subgroup 1, double the sample size of the failed test or sequence of tests. A failure in [table I](#), subgroup 1 shall not require retest of the entire subgroup. Only the failed test shall be rerun upon submission.

3/ Separate samples may be used.

4/ Not required for JANS devices.

5/ Not required for laser marked devices.

MIL-PRF-19500/357M

TABLE II. Group D inspection.

Inspection <u>1/ 2/ 3/</u>	MIL-STD-750		Symbol	Limit		Unit
	Method	Conditions		Min	Max	
<u>Subgroup 1 4/</u>						
Neutron irradiation	1017	Neutron exposure $V_{CES} = 0$ V				
Collector to base, cutoff current	3036	Bias condition D				
2N3634, 2N3634L, UB, UBN		$V_{CB} = 140$ V dc	I_{CBO1}		20	μ A dc
2N3635, 2N3635L, UB, UBN		$V_{CB} = 140$ V dc	I_{CBO1}		20	μ A dc
2N3636, 2N3636L, UB, UBN		$V_{CB} = 175$ V dc	I_{CBO1}		20	μ A dc
2N3637, 2N3637L, UB, UBN		$V_{CB} = 175$ V dc	I_{CBO1}		20	μ A dc
Emitter to base, cutoff current	3061	Bias condition D, $V_{EB} = 5$ V dc	I_{EBO1}		20	μ A dc
Breakdown voltage, collector to emitter	3011	Bias condition D, $I_C = 10$ mA dc pulsed (see 4.5.1)	$V_{(BR)CEO}$			
2N3634, 2N3634L, UB, UBN				140		V dc
2N3635, 2N3635L, UB, UBN						
2N3636, 2N3636L, UB, UBN				175		V dc
2N3637, 2N3637L, UB, UBN						
Collector to base cutoff current	3036	Bias condition D, $V_{CB} = 100$ V dc	I_{CBO2}		200	nA dc
Emitter to base cutoff current	3061	Bias condition D, $V_{EB} = 3$ V dc	I_{EBO2}		100	nA dc
Collector to emitter cutoff current	3041	Bias condition D, $V_{CE} = 100$ V dc	I_{CEO}		20	μ A dc
Forward-current transfer ratio	3076	$V_{CE} = 10$ V dc; $I_C = 0.1$ mA dc	$[h_{FE1}]$ <u>5/</u>			
2N3634, 2N3636				[12.5]		
2N3635, 2N3637				[27.5]		
Forward-current transfer ratio	3076	$V_{CE} = 10$ V dc; $I_C = 1.0$ mA dc	$[h_{FE2}]$ <u>5/</u>			
2N3634, 2N3636				[22.5]		
2N3635, 2N3637				[45]		
Forward-current transfer ratio	3076	$V_{CE} = 10$ V dc; $I_C = 10$ mA dc	$[h_{FE3}]$ <u>5/</u>			
2N3634, 2N3636				[25]		
2N3635, 2N3637				[50]		
Forward-current transfer ratio	3076	$V_{CE} = 10$ V dc; $I_C = 50$ mA dc	$[h_{FE4}]$ <u>5/</u>			
2N3634, 2N3636				[25]	150	
2N3635, 2N3637				[50]	300	

See footnotes at end of table.

MIL-PRF-19500/357M

TABLE II. Group D inspection - Continued.

Inspection <u>1/ 2/ 3/</u>	MIL-STD-750		Symbol	Limit		Unit
	Method	Conditions		Min	Max	
<u>Subgroup 1</u> - Continued.						
Forward-current transfer ratio 2N3634, 2N3636 2N3635, 2N3637	3076	$V_{CE} = 10 \text{ V dc}; I_C = 150 \text{ mA dc}$	$[h_{FE5}] \underline{5/}$	[15] [30]		
Collector-emitter saturation voltage	3071	$I_C = 10 \text{ mA dc}; I_B = 1.0 \text{ mA dc}$	$V_{CE(sat)1}$.35	V dc
Collector-emitter saturation voltage	3071	$I_C = 50 \text{ mA dc}; I_B = 5.0 \text{ mA dc}$	$V_{CE(sat)2}$.69	V dc
Base-emitter voltage (saturated)	3066	Test condition A; $I_C = 10 \text{ mA dc}$, $I_B = 1.0 \text{ mA dc}$ pulsed (see 4.5.1)	$V_{BE(sat)1}$		0.92	V dc
Base-emitter voltage (saturated)	3066	Test condition A; $I_C = 50 \text{ mA dc}$, $I_B = 5 \text{ mA dc}$ pulsed (see 4.5.1)	$V_{BE(sat)2}$		1.04	V dc
<u>Subgroup 2</u>						
Total dose irradiation 2N3634, 2N3636 2N3635, 2N3637	1019	Gamma exposure $V_{CES} = 112 \text{ V}$ $V_{CES} = 140 \text{ V}$				
Collector to base, cutoff current 2N3634, 2N3634L, UB, UBN 2N3635, 2N3635L, UB, UBN 2N3636, 2N3636L, UB, UBN 2N3637, 2N3637L, UB, UBN	3036	Bias condition D $V_{CB} = 140 \text{ V dc}$ $V_{CB} = 140 \text{ V dc}$ $V_{CB} = 175 \text{ V dc}$ $V_{CB} = 175 \text{ V dc}$	I_{CBO1} I_{CBO1} I_{CBO1} I_{CBO1}		20 20 20 20	$\mu\text{A dc}$ $\mu\text{A dc}$ $\mu\text{A dc}$ $\mu\text{A dc}$
Emitter to base, cutoff current	3061	Bias condition D, $V_{EB} = 5 \text{ V dc}$	I_{EBO1}		20	$\mu\text{A dc}$
Breakdown voltage, collector to emitter 2N3634, 2N3634L, UB, UBN 2N3635, 2N3635L, UB, UBN 2N3636, 2N3636L, UB, UBN 2N3637, 2N3637L, UB, UBN	3011	Bias condition D, $I_C = 10 \text{ mA dc}$ pulsed (see 4.5.1)	$V_{(BR)CEO}$		140 175	V dc V dc
Collector to base cutoff current	3036	Bias condition D, $V_{CB} = 100 \text{ V dc}$	I_{CBO2}		200	nA dc
Emitter to base cutoff current	3061	Bias condition D, $V_{EB} = 3 \text{ V dc}$	I_{EBO2}		100	nA dc
Collector to emitter cutoff current	3041	Bias condition D, $V_{CE} = 100 \text{ V dc}$	I_{CEO}		20	$\mu\text{A dc}$

See footnotes at end of table.

MIL-PRF-19500/357M

TABLE II. Group D inspection - Continued.

Inspection <u>1/</u> <u>2/</u> <u>3/</u>	MIL-STD-750		Symbol	Limit		Unit
	Method	Conditions		Min	Max	
<u>Subgroup 2</u> - Continued.						
Forward-current transfer ratio 2N3634, 2N3636 2N3635, 2N3637	3076	$V_{CE} = 10 \text{ V dc}; I_C = 0.1 \text{ mA dc}$	$[h_{FE1}]$ <u>5/</u>	[12.5] [27.5]		
Forward-current transfer ratio 2N3634, 2N3636 2N3635, 2N3637	3076	$V_{CE} = 10 \text{ V dc}; I_C = 1.0 \text{ mA dc}$	$[h_{FE2}]$ <u>5/</u>	[22.5] [45]		
Forward-current transfer ratio 2N3634, 2N3636 2N3635, 2N3637	3076	$V_{CE} = 10 \text{ V dc}; I_C = 10 \text{ mA dc}$	$[h_{FE3}]$ <u>5/</u>	[25] [50]		
Forward-current transfer ratio 2N3634, 2N3636 2N3635, 2N3637	3076	$V_{CE} = 10 \text{ V dc}; I_C = 50 \text{ mA dc}$	$[h_{FE4}]$ <u>5/</u>	[25] [50]	150 300	
Forward-current transfer ratio 2N3634, 2N3636 2N3635, 2N3637	3076	$V_{CE} = 10 \text{ V dc}; I_C = 150 \text{ mA dc}$	$[h_{FE5}]$ <u>5/</u>	[15] [30]		
Collector-emitter saturation voltage	3071	$I_C = 10 \text{ mA dc}; I_B = 1.0 \text{ mA dc};$	$V_{CE(sat)1}$.35	V dc
Collector-emitter saturation voltage	3071	$I_C = 50 \text{ mA dc}; I_B = 5.0 \text{ mA dc};$	$V_{CE(sat)2}$.69	V dc
Base-emitter voltage (saturated)	3066	Test condition A; $I_C = 10 \text{ mA dc}, I_B = 1.0 \text{ mA dc}$ pulsed (see 4.5.1)	$V_{BE(sat)1}$		0.92	V dc
Base-emitter voltage (saturated)	3066	Test condition A; $I_C = 50 \text{ mA dc}, I_B = 5 \text{ mA dc}$ pulsed (see 4.5.1)	$V_{BE(sat)2}$		1.04	V dc

1/ Tests to be performed on all devices receiving radiation exposure.

2/ For sampling plan, see MIL-PRF-19500.

3/ Electrical characteristics apply to device types unless otherwise noted.

4/ Subgroup 1 is an optional test and must be specified on the contract when required.

5/ See method 1019 of MIL-STD-750 for how to determine $[h_{FR}]$ by first calculating the delta ($1/h_{FE}$) from the pre- and post-radiation h_{FE} . Notice the $[h_{FE}]$ is not the same as h_{FE} and cannot be measured directly. The $[h_{FE}]$ value can never exceed the pre-radiation minimum h_{FE} that it is based upon.

MIL-PRF-19500/357M

* TABLE III. Group E inspection (all quality levels) - for qualification only.

Inspection	MIL-STD-750		Qualification
	Method	Conditions	
<u>Subgroup 1</u>			45 devices c = 0
Temperature cycling (air to air)	1051	Test condition C, 500 cycles	
Hermetic seal	1071		
Fine leak Gross leak			
Electrical measurements		See table I , subgroup 2 and 4.5.4 herein.	
<u>Subgroup 2</u>			45 devices c = 0
Intermittent life	1037	$V_{CB} = 10$ V dc, 6,000 cycles. Adjust device current, or power, to achieve a minimum ΔT_J of +100°C.	
Electrical measurements		See table I of subgroup 2 and 4.5.4 herein.	
<u>Subgroup 4</u>			15 devices, c = 0
Thermal resistance	3131	$R_{\theta JSP}$ can be calculated but shall be measured once in the same package with a similar die size to confirm calculations (may apply to multiple specification sheets).	
Thermal impedance curves		See MIL-PRF-19500, table E-IX, group E, subgroup 4.	Sample size N/A
<u>Subgroup 5</u>			
Not applicable			
<u>Subgroup 6</u>			11 devices
ESD	1020		
<u>Subgroup 8</u>			45 devices c = 0
Reverse stability	1033	Condition B.	

Temperature-Power Derating Curve

TA=25°C 2N3634, 2N3635, 2N3636, 2N3637

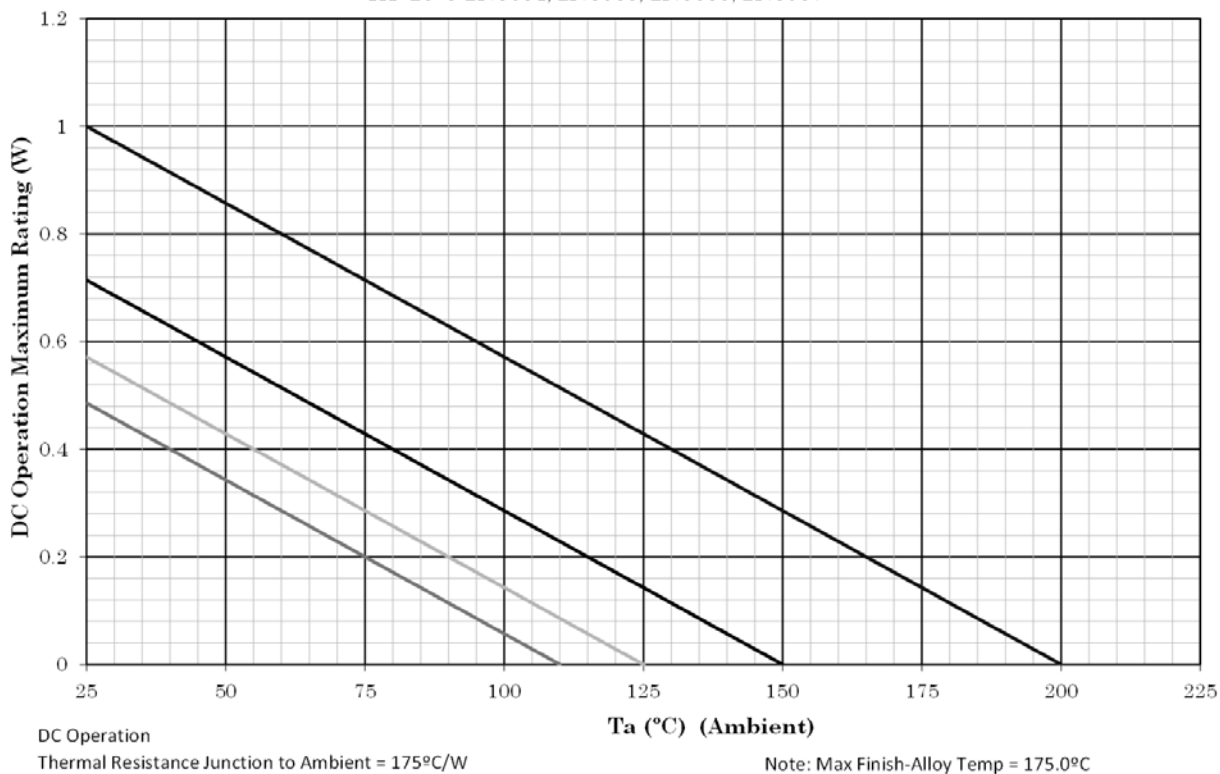

NOTES:

1. This is the true inverse of the worst case thermal resistance value. All devices are capable of operating at $\leq T_J$ specified on this curve. Any parallel line to this curve will intersect the appropriate power for the desired maximum T_J allowed.
2. Derate design curve constrained by the maximum junction temperature ($T_J \leq 200^\circ\text{C}$) and power rating specified. (See 1.3 herein.)
3. Derate design curve chosen at $T_J \leq 150^\circ\text{C}$, where the maximum temperature of electrical test is performed.
4. Derate design curve chosen at $T_J \leq 125^\circ\text{C}$, and 110°C to show power rating where most users want to limit T_J in their application.

* FIGURE 5. Temperature-power derating for ($R_{\theta JA}$), base case mount (TO-5 and TO-39).

Temperature-Power Derating Curve

TA=25°C 2N3634UB, 2N3635UB, 2N3636UB, 2N3637UB

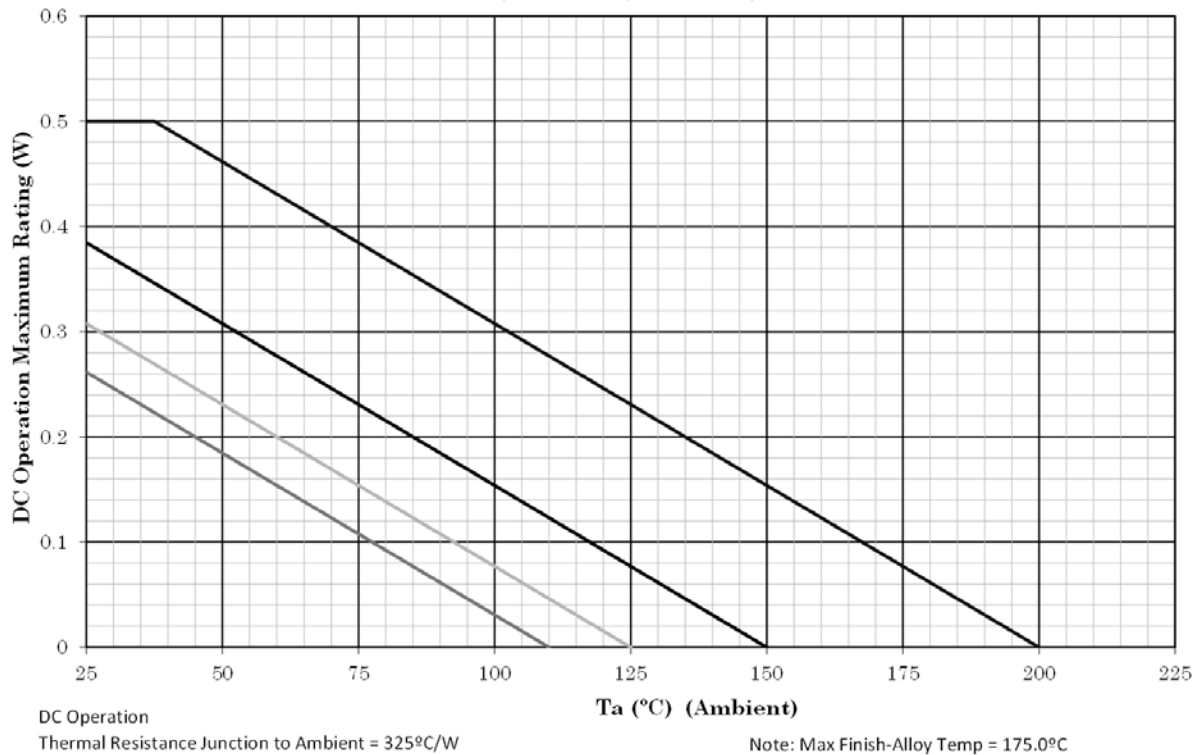

NOTES:

1. This is the true inverse of the worst case thermal resistance value. All devices are capable of operating at $\leq T_J$ specified on this curve. Any parallel line to this curve will intersect the appropriate power for the desired maximum T_J allowed.
2. Derate design curve constrained by the maximum junction temperature ($T_J \leq 200^\circ\text{C}$) and power rating specified. (See 1.3 herein.)
3. Derate design curve chosen at $T_J \leq 150^\circ\text{C}$, where the maximum temperature of electrical test is performed.
4. Derate design curve chosen at $T_J \leq 125^\circ\text{C}$, and 110°C to show power rating where most users want to limit T_J in their application.

* FIGURE 6. Temperature-power derating for ($R_{\theta JA}$) (UB AND UBN).

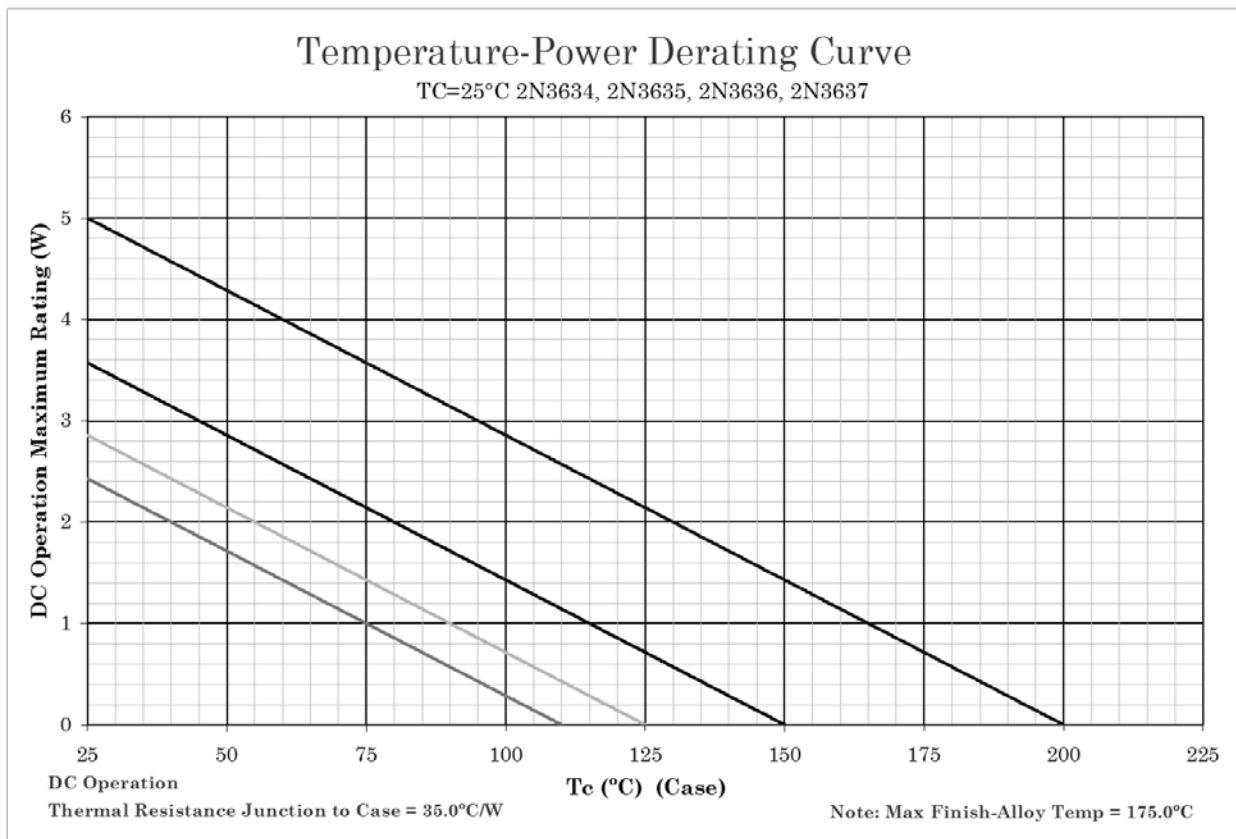

NOTES:

1. This is the true inverse of the worst case thermal resistance value. All devices are capable of operating at $\leq T_J$ specified on this curve. Any parallel line to this curve will intersect the appropriate power for the desired maximum T_J allowed.
2. Derate design curve constrained by the maximum junction temperature ($T_J \leq 200^\circ\text{C}$) and power rating specified. (See 1.3 herein.)
3. Derate design curve chosen at $T_J \leq 150^\circ\text{C}$, where the maximum temperature of electrical test is performed.
4. Derate design curve chosen at $T_J \leq 125^\circ\text{C}$, and 110°C to show power rating where most users want to limit T_J in their application.

FIGURE 7. Temperature-power derating for ($R_{\theta JC}$), base case mount (TO-5 and TO-39 Kovar).

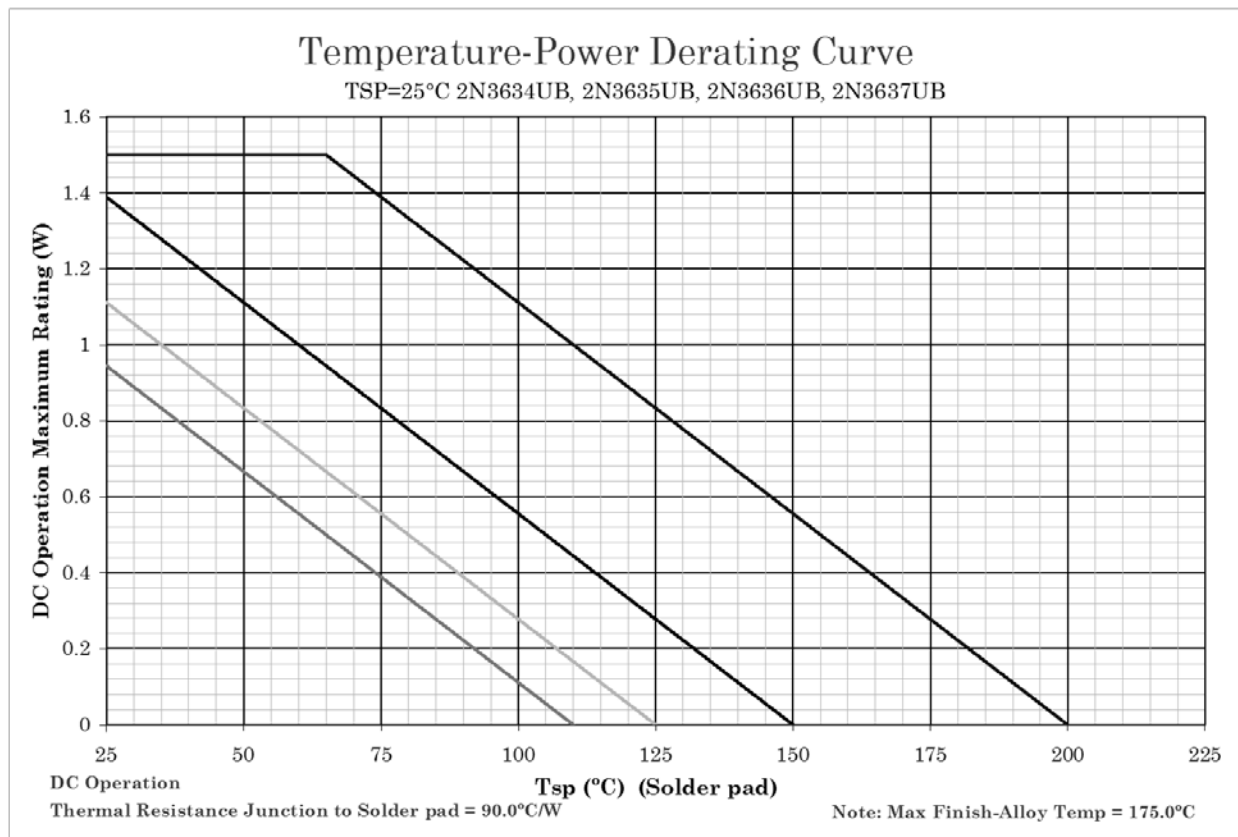

NOTES:

1. This is the true inverse of the worst case thermal resistance value. All devices are capable of operating at $\leq T_J$ specified on this curve. Any parallel line to this curve will intersect the appropriate power for the desired maximum T_J allowed.
2. Derate design curve constrained by the maximum junction temperature ($T_J \leq 200^\circ\text{C}$) and power rating specified. (See 1.3 herein.)
3. Derate design curve chosen at $T_J \leq 150^\circ\text{C}$, where the maximum temperature of electrical test is performed.
4. Derate design curve chosen at $T_J \leq 125^\circ\text{C}$, and 110°C to show power rating where most users want to limit T_J in their application.

FIGURE 8. Temperature-power derating for ($R_{\theta_{JSP}}$), base case mount (UB AND UBN).

Maximum Thermal Impedance

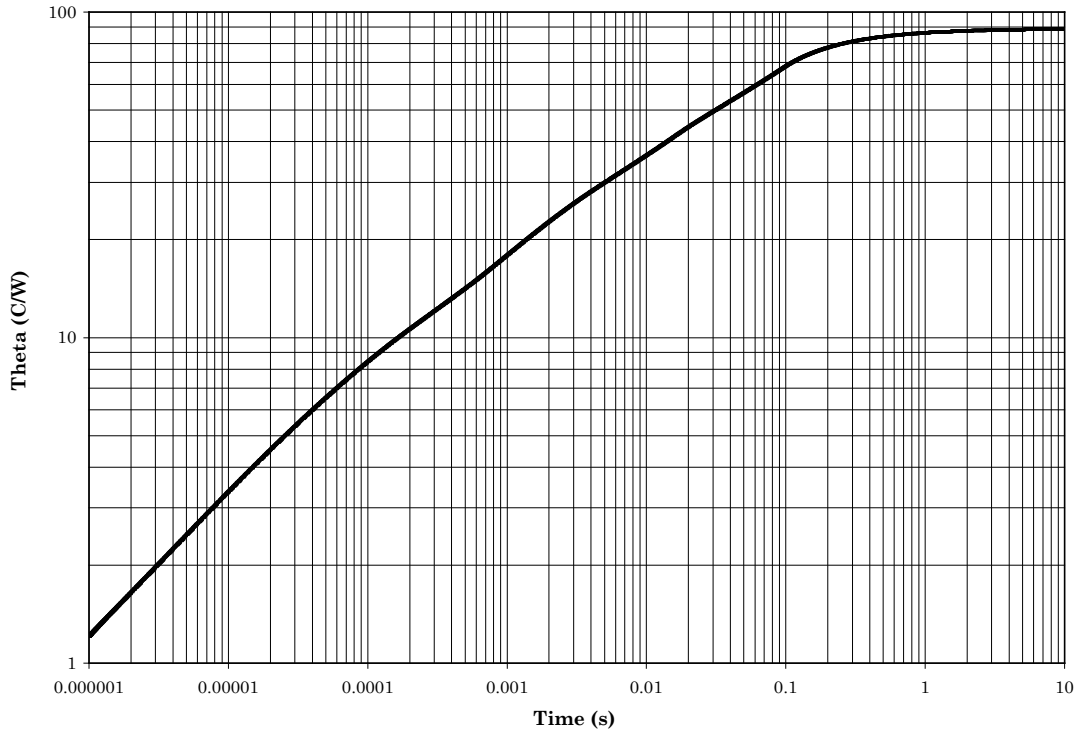

$T_{SP} = +25^{\circ}\text{C}$, thermal resistance $R_{\theta_{JSP}} = 90^{\circ}\text{C/W}$ (solder mounted to heavy copper clad PCB).

* FIGURE 9. Thermal impedance graph ($R_{\theta_{JSP}}$) for 2N3634UB through 2N3637UB (UB AND UBN).

Maximum Thermal Impedance

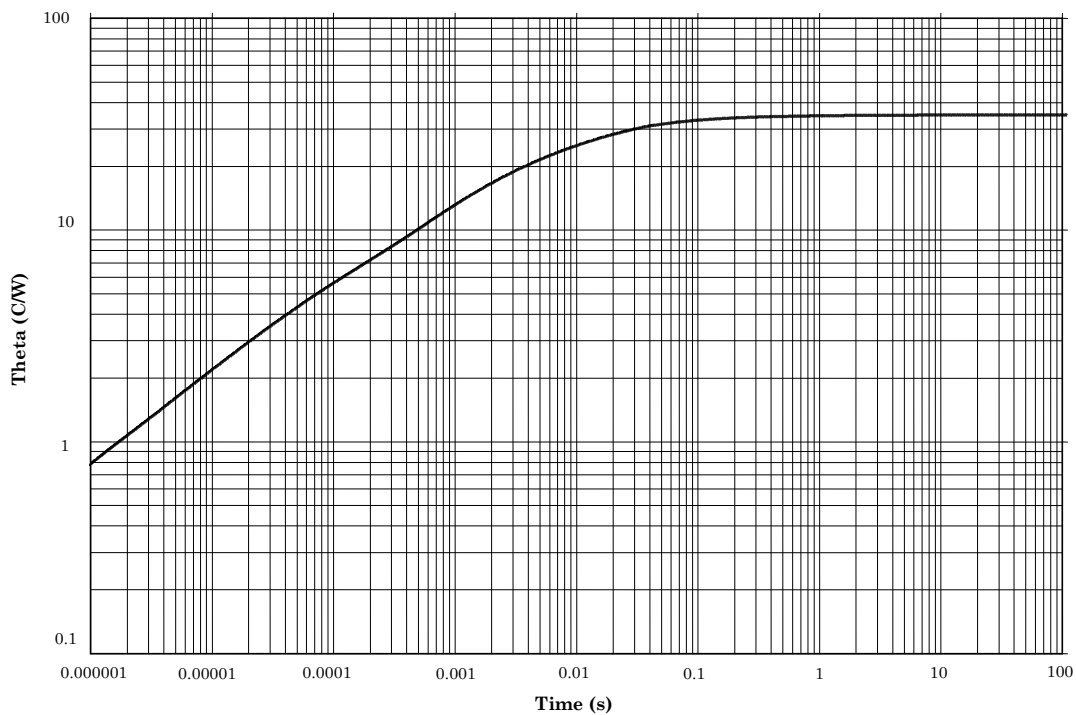

$T_C = +25^\circ\text{C}$, thermal resistance $R_{\theta JC} = 35^\circ\text{C/W}$ (ambient case mount).

FIGURE 10. Thermal impedance graph ($R_{\theta JC}$) for 2N3634 through 2N3637 and 2N3634L through 2N3637L (TO-5 and TO-39 Kovar).

Maximum Thermal Impedance

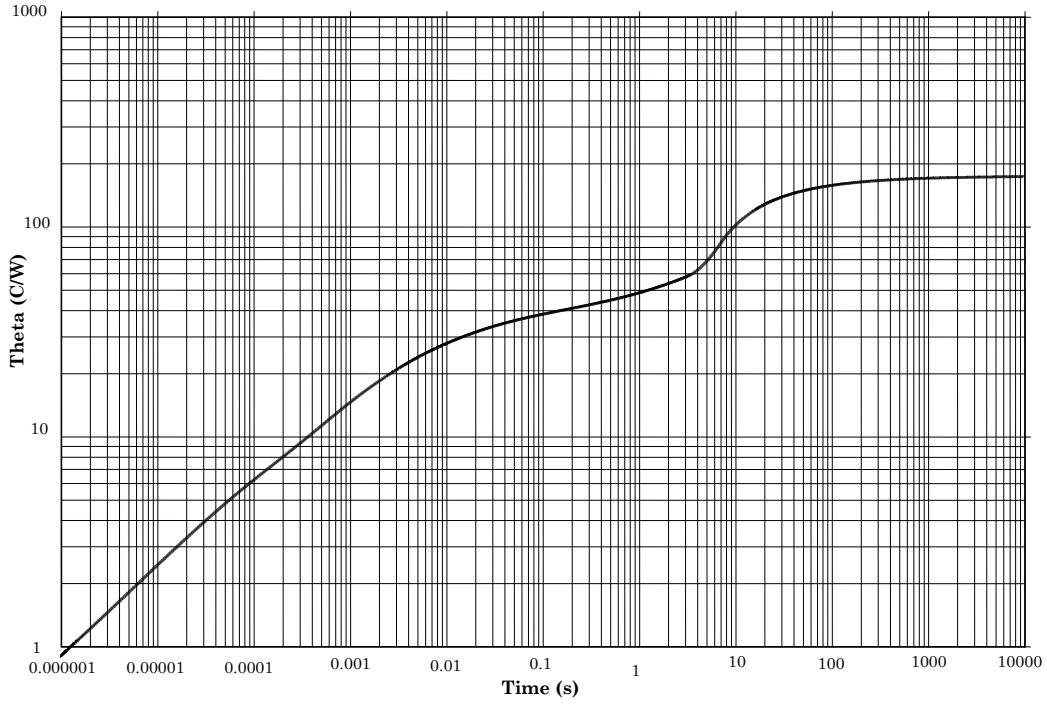

$T_A = +25^\circ\text{C}$, thermal resistance $R_{\theta JA} = 175^\circ\text{C/W}$ (ambient free air cooled).

FIGURE 11. Thermal impedance graph ($R_{\theta JA}$) for 2N3634 through 2N3637 and 2N3634L through 2N3637L (TO-5 and TO-39).

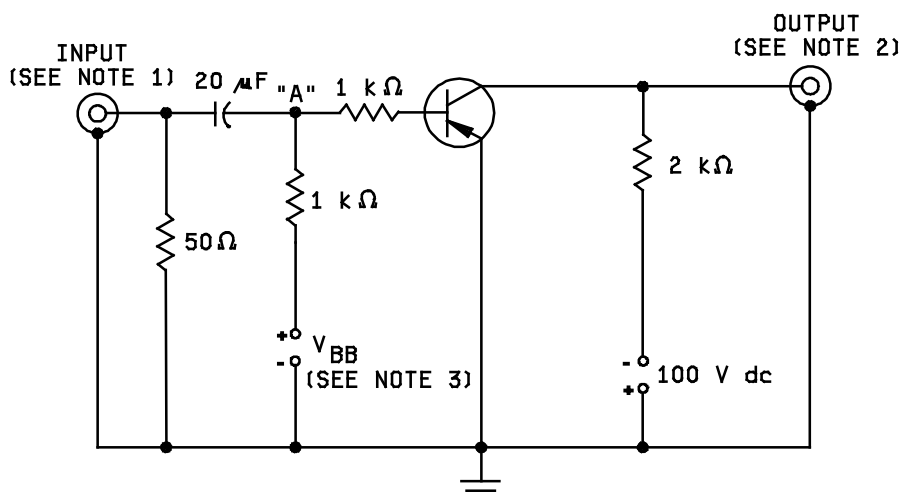

TEST CIRCUIT

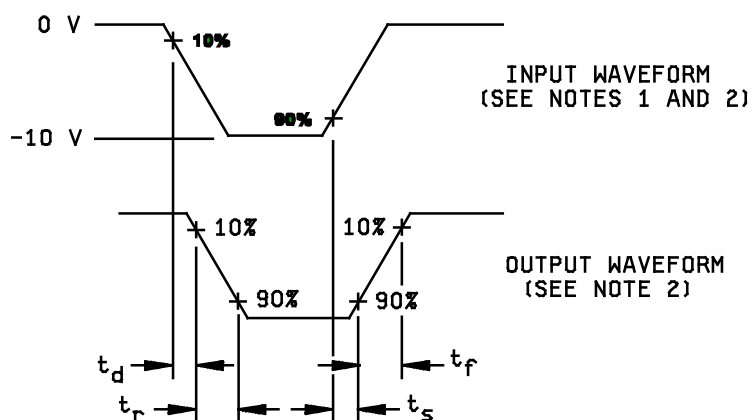

NOTES:

1. The input waveform is supplied by a pulse generator with the following characteristics:
 $t_r \leq 15 \text{ ns}$, $t_f \leq 15 \text{ ns}$, $Z_{\text{OUT}} = 50 \Omega$, $\text{PW} = 20 \mu\text{s}$, duty cycle ≤ 2 percent.
2. Output waveforms are monitored on an oscilloscope with the following characteristics: $t_r \leq 15 \text{ ns}$, $R_{\text{in}} \geq 10 \text{ M}\Omega$, $C_{\text{in}} \leq 11.5 \text{ pF}$.
3. $V_{\text{BB}} = 4.0 \text{ V dc}$ for t_{on} , 4.1 V dc for t_{off} at point "A".
4. Resistors shall be noninductive types.
5. The dc power supplies may require additional by-passing in order to minimize ringing.

FIGURE 12. Pulse response test circuit.

SOA Power Curve - Safe Design $T_j=200C$ Rating

TO-39 at $T_a=25C$ (Air Mounted)

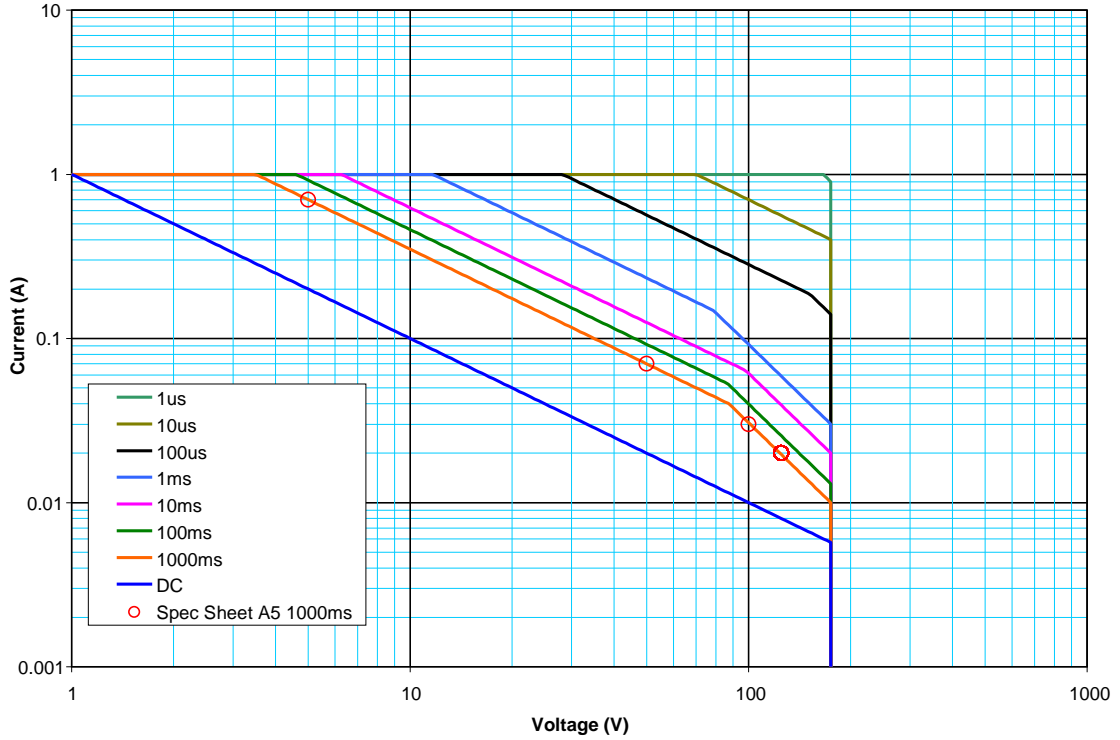

2N3637 $T_A = +25^{\circ}C$. A5 limits at 1,000 ms.
 $V_{CE} = 5V$ at 0.7A,
 $V_{CE} = 50V$ at 0.07A,
 $V_{CE} = 100V$ at 0.03A,
 $V_{CE} = 125V$ at 0.02A.

FIGURE 13. Maximum safe operating area graph (continuous dc).

SOA Power Curve - Safe Design Tj=200C Rating

2N3637 ss357 TO-39 at Tc=25C (Case Mounted)

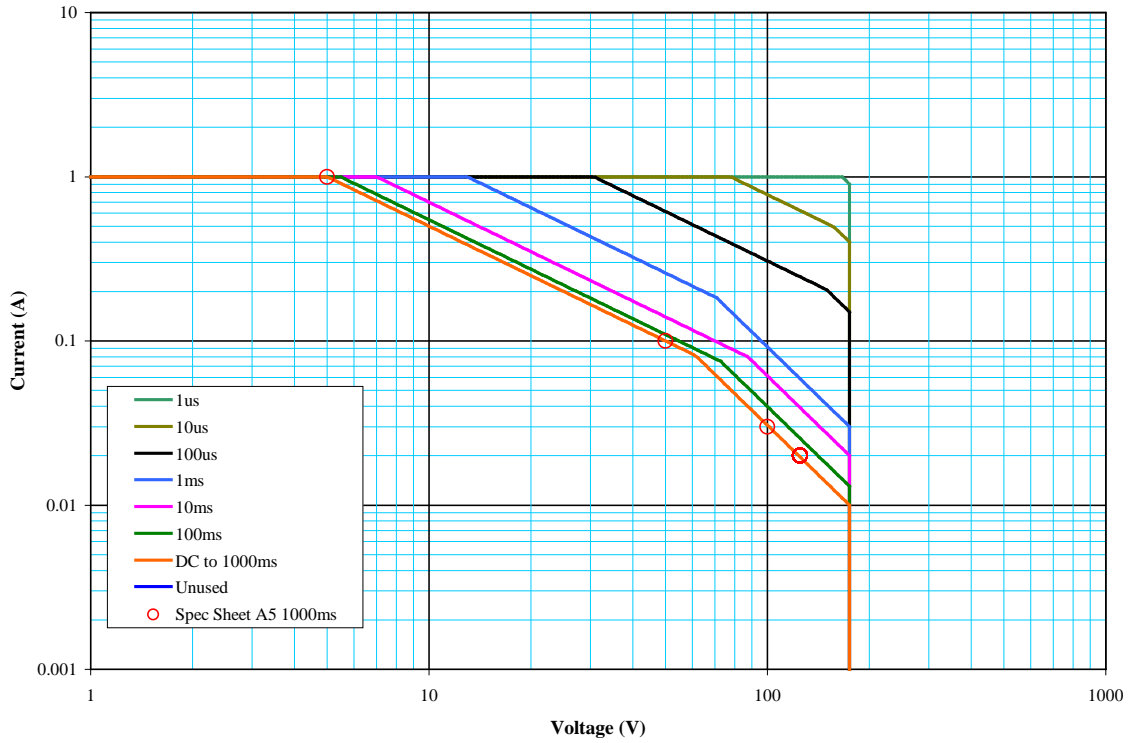

2N3637 $T_C = +25^\circ\text{C}$. A5 limits at 1,000 ms.
 $V_{CE} = 5\text{V}$ at 1A,
 $V_{CE} = 50\text{V}$ at 0.095A,
 $V_{CE} = 100\text{V}$ at 0.03A,
 $V_{CE} = 130\text{V}$ at 0.02A.

FIGURE 14. Maximum safe operating area graph (continuous dc).

SOA Power Curve - Safe Design Tj=200C Rating

UB at Ta=25C (FR4 PCB Mount)

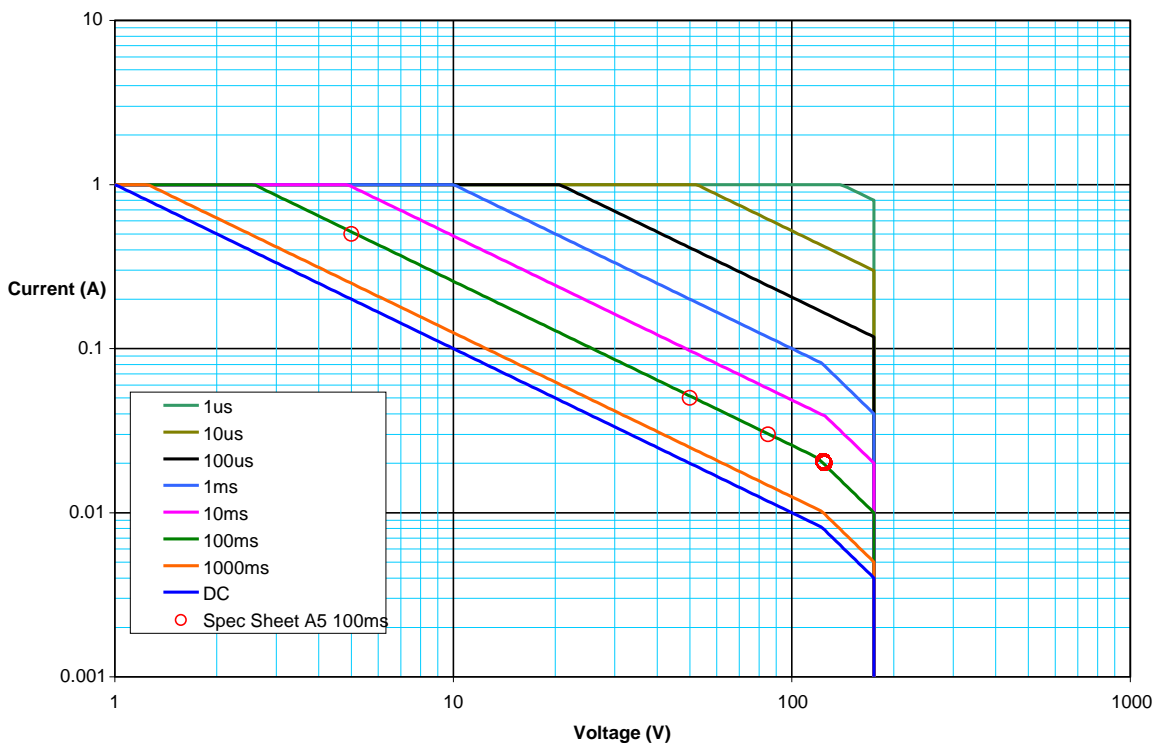

2N3637UB $T_A = +25^\circ\text{C}$. A5 limits at 100 ms.

$V_{CE} = 5\text{V}$ at 0.5A,

$V_{CE} = 50\text{V}$ at 0.05A,

$V_{CE} = 85\text{V}$ at 0.03A,

$V_{CE} = 125\text{V}$ at 0.02A.

FIGURE 15. Maximum safe operating area graph for UB AND UBN (continuous dc).

SOA Power Curve - Safe Design Tj=200C Rating

2N3637UB ss357 LCC3 at Tsp=25C (Maximum Sink)

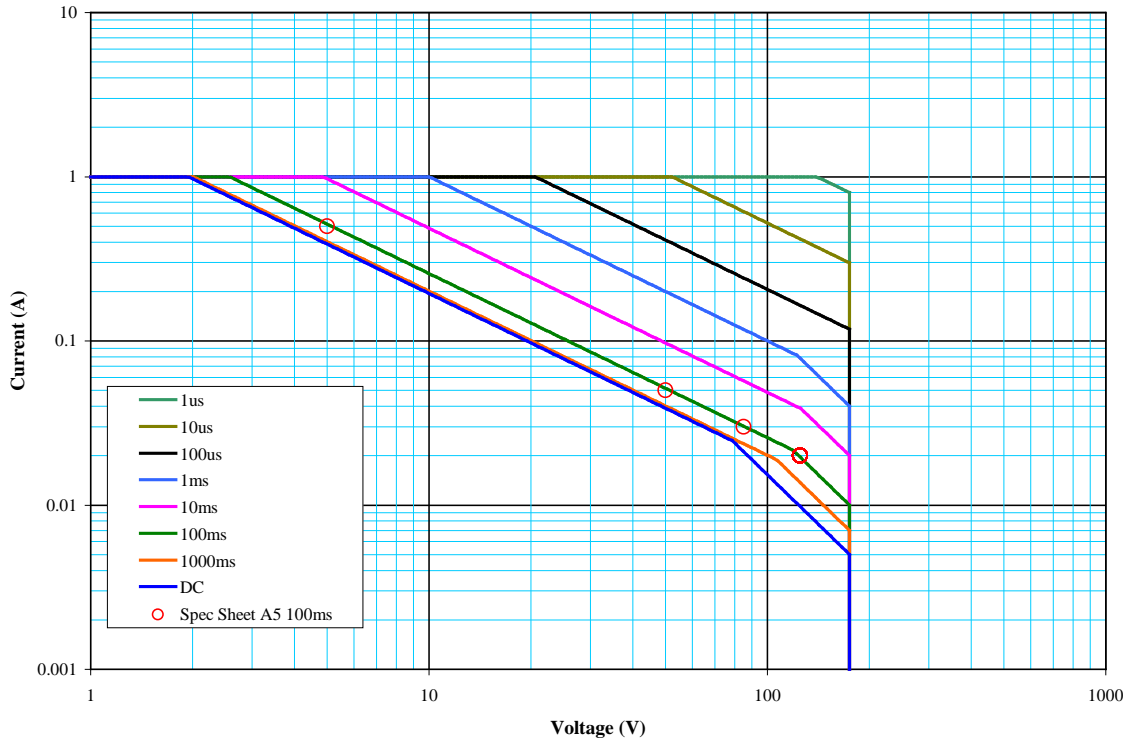

2N3637UB $T_{SP} = +25^{\circ}C$. A5 limits at 100 ms.
 $V_{CE} = 5V$ at 0.5A,
 $V_{CE} = 50V$ at 0.05A,
 $V_{CE} = 85V$ at 0.03A,
 $V_{CE} = 125V$ at 0.02A.

FIGURE 16. Maximum safe operating area graph for UB AND UBN (continuous dc).

5. PACKAGING

5.1 Packaging. For acquisition purposes, the packaging requirements shall be as specified in the contract or order (see 6.2). When packaging of materiel is to be performed by DoD or in-house contractor personnel, these personnel need to contact the responsible packaging activity to ascertain packaging requirements. Packaging requirements are maintained by the Inventory Control Point's packaging activities within the Military Service or Defense Agency, or within the Military Service's system commands. Packaging data retrieval is available from the managing Military Department's or Defense Agency's automated packaging files, CD-ROM products, or by contacting the responsible packaging activity.

6. NOTES

(This section contains information of a general or explanatory nature that may be helpful, but is not mandatory. The notes specified in MIL-PRF-19500 are applicable to this specification.)

6.1 Intended use. Semiconductors conforming to this specification are intended for original equipment design applications and logistic support of existing equipment.

6.2 Acquisition requirements. Acquisition documents should specify the following:

- a. Title, number, and date of this specification.
- b. Packaging requirements (see 5.1).
- c. Lead finish (see 3.4.1).
- d. Product assurance level and type designator.
- e. For die acquisition, the JANHC or JANKC letter version shall be specified (see figure 3).
- f. Surface mount designation if applicable.
- g. For acquisition of RHA designed devices, table II, subgroup 1 testing of group D is optional. If subgroup 1 testing is desired, it must be specified in the contract.

* 6.3 Qualification. With respect to products requiring qualification, awards will be made only for products which are, at the time of award of contract, qualified for inclusion in Qualified Manufacturers List (QML 19500) whether or not such products have actually been so listed by that date. The attention of the contractors is called to these requirements, and manufacturers are urged to arrange to have the products that they propose to offer to the Federal Government tested for qualification in order that they may be eligible to be awarded contracts or orders for the products covered by this specification. Information pertaining to qualification of products may be obtained from DLA Land and Maritime, ATTN: /VQE, P.O. Box 3990, Columbus, OH 43218-3990 or e-mail vqe.chief@dla.mil. An online listing of products qualified to this specification may be found in the Qualified Products Database (QPD) at <https://assist.dla.mil>.

6.4 Supersession information. Devices covered by this specification supersede the manufacturers' and users' Part or Identifying Number (PIN). The term Part or Identifying Number (PIN) is equivalent to the term part number which was previously used in this specification. This information in no way implies that manufacturers' PINs are suitable as a substitute for the military PIN.

* 6.5 Suppliers of JANHC and JANKC die. The qualified JANHC and JANKC suppliers with the applicable letter version (example JANHCA2N3634) will be identified on the QML.

JANHC and JANKC ordering information		
PIN	Manufacturer	
	43611	31471
2N3634	JANHCA2N3634, JANKCA2N3634	JANHCB2N3634, JANKCB2N3634
2N3635	JANHCA2N3635, JANKCA2N3635	JANHCB2N3635, JANKCB2N3635
2N3636	JANHCA2N3636, JANKCA2N3636	JANHCB2N3636, JANKCB2N3636
2N3637	JANHCA2N3637, JANKCA2N3637	JANHCB2N3637, JANKCB2N3637

6.6 Changes from previous issue. The margins of this specification are marked with asterisks to indicate where changes from the previous issue were made. This was done as a convenience only and the Government assumes no liability whatsoever for any inaccuracies in these notations. Bidders and contractors are cautioned to evaluate the requirements of this document based on the entire content irrespective of the marginal notations and relationship to the last previous issue.

Custodians:
 Army - CR
 Navy - EC
 Air Force - 85
 NASA - NA
 DLA - CC

Preparing activity:
 DLA - CC
 (Project 5961-2012-088)

Review activities:
 Army - AR, MI, SM
 Navy - AS, MC, SH
 Air Force - 19, 71

* NOTE: The activities listed above were interested in this document as of the date of this document. Since organizations and responsibilities can change, you should verify the currency of the information above using the ASSIST Online database at <https://assist.dla.mil>.

X-ON Electronics

Largest Supplier of Electrical and Electronic Components

Click to view similar products for [semicoa](#) manufacturer:

Other Similar products are found below :

[JANS2N2907AUA](#) [JANTXV2N2907AUB](#) [JANTXV2N4033UB](#) [GRP-DATA-JANS2N2222A](#) [GRP-DATA-JANS2N3700](#) [GRP-DATA-JANS2N3866A](#) [JANTXV2N6193](#) [GRP-DATA-JANS2N2907AUB](#) [JANTX2N4150](#) [JANTX2N5237](#) [2N4033JANTX](#) [2N2907AJAN](#) [JANTX2N3737](#) [JANTX2N3637](#) [2N3019JVJANTXV](#) [JANTX2N2222AUB](#) [JANTX2N2907AUA](#) [2N3501JANTX](#) [2N6193JANTXV](#) [2N3737JANTX](#) [2N3637JANTX](#) [JANS2N2369A](#) [JANS2N4033UB](#) [2N3501JAN](#) [JANSR2N6990](#) [2N3811JANTX](#) [2N2222AUAJANTX](#) [JANS2N2222AUB](#) [JANS2N3501UB](#) [2N2369AUBJANTX](#) [JANTX2N4261](#) [2N3486AJANTX](#) [2N3507JANTX](#) [2N2857JANTX](#) [2N3499JANTX](#) [2N2219AJANTX](#) [JANTX2N4029](#) [2N2906AJAN](#) [JANTX2N6193](#) [2N3637UBJANTXV](#) [2N2907AUAJANTXV](#) [2N3810JANTX](#) [2N2484JANTX](#) [JANTX2N2222AUA](#) [2N3019JANTX](#) [2N6193JANTX](#) [2N2905AJANTX](#) [2N3700UBJANTXV](#) [JANTXV2N2907A](#) [2N3700JANTX](#)