

xRSB-50Txxx

Isolated DC-DC Converter

The xRSB-50T series are isolated DC-DC converters that operate from a nominal 48 VDC source. These units will provide up to 60 W of output power from a nominal 48 VDC input. These units are designed to be highly efficient and low cost.

Features include remote on/off, over current protection and under voltage lockout. These converters are provided in an industry standard sixteenth brick package.



Key Features & Benefits

- 48 VDC Input / 1.5-12 VDC @ 5-22 A Output / 1/16th Brick Converter
- Isolated
- Fixed Frequency (600 kHz)
- High Efficiency
- High Power Density
- Low Cost
- Input Under Voltage Lockout
- Output Voltage Trim
- Output Over Voltage Shutdown
- OCP/SCP
- Over Temperature Protection
- Remote On/Off
- Basic Insulation
- Positive/Negative remote sense
- Through Hole and SMT (option)
- Approved to UL/CSA/IEC60950-1, 2nd +A2 version
- Class II, Category 2, Non-Isolated DC/DC Converter (refer to IPC-9592B)

Applications

- Networking
- Computers and Peripherals
- Telecommunications



bel POWER
SOLUTIONS &
PROTECTION

a bel group

belfuse.com/power-solutions

1. MODEL SELECTION

MODEL NUMBER	MODEL NUMBER	OUTPUT VOLTAGE	INPUT VOLTAGE	MAX. OUTPUT CURRENT	MAX. OUTPUT POWER	TYPICAL EFFICIENCY
xRSB-50TV5L	xRSB-50TV50	1.5 V	36 V - 75 V	22 A	33 W	85%
xRSB-50TV8L	xRSB-50TV80	1.8 V	36 V - 75 V	20 A	36 W	87%
xRSB-50T02L	xRSB-50T025	2.5 V	36 V - 75 V	18 A	45 W	87%
xRSB-50T03L	xRSB-50T033	3.3 V	36 V - 75 V	15 A	50 W	89%
xRSB-50T05L	xRSB-50T050	5.0 V	36 V - 75 V	12 A	60 W	90%
xRSB-50T12L	xRSB-50T120	12 V	36 V - 75 V	5 A	60 W	89%

NOTE: Add "G" or "H" suffix at the end of the model number to indicate tray packaging and "R" or "S" to indicate Tape and Reel packaging.

PART NUMBER EXPLANATION

x	R	SB	-	50	T	xx	x	y
Mounting Type	RoHS Status	Series Name	Series code	Input Range	Output Voltage	Active Logic	Package Type	
0 - Through hole mount	RoHS	1/16 th Brick	-	36 - 75 V	1.5-12V	0,3,5- active high	G/H - Tray package	
S - Surface mount						L - active low	R/S - Tape and Reel package	

2. ABSOLUTE MAXIMUM RATINGS

PARAMETER	DESCRIPTION	MIN	TYP	MAX	UNIT
Continuous non-operating Input Voltage		-0.3	-	80	V
Input Transient Voltage	100 ms maximum	-0.3	-	100	V
Remote On/Off		-0.3	-	18	V
I/O Isolation Voltage		-	-	1500	V
Ambient Temperature		-40	-	85	°C
Storage Temperature		-55	-	125	°C
Altitude		-	-	2000	m

NOTE: Ratings used beyond the maximum ratings may cause a reliability degradation of the converter or may permanently damage the device.

3. INPUT SPECIFICATIONS

All specifications are typical at 25°C unless otherwise stated.

PARAMETER	DESCRIPTION	MIN	TYP	MAX	UNIT
Operating Input Voltage		36	48	75	V
Input Current (full load)		-	-	2.4	A
Input Current (no load)		-	70	120	mA
Remote Off Input Current		-	1	3	mA
Input Reflected Ripple Current (rms)	Tested with simulated source impedance of 15 uH, 5 Hz to 20 MHz; use a 100 uF/100 V electrolytic capacitor with ESR=1 ohm max at 200 kHz at the input.	-	3	7	mA
Input Reflected Ripple Current (pk-pk)		-	20	50	mA
I ² t Inrush Current Transient		-	0.01	0.02	A ² s
Turn-on Voltage Threshold		31	32	35	V
Turn-off Voltage Threshold		30	31	34	V

NOTES: All specifications are typical at 25 °C unless otherwise stated.

4. OUTPUT SPECIFICATIONS

All specifications are typical at nominal input, full load at 25°C unless otherwise stated.

PARAMETER	DESCRIPTION	MIN	TYP	MAX	UNIT
Output Voltage Set Point	Vo=1.5 V	1.478	1.5	1.523	V
	Vo=1.8 V	1.773	1.8	1.827	V
	Vo=2.5 V	2.463	2.5	2.538	V
	Vo=3.3 V	3.250	3.3	3.350	V
	Vo=5.0V	4.925	5.0	5.075	V
	Vo=12 V	11.750	12.0	12.250	V
Load Regulation	Vo=1.5-1.8 V	-	±0.5	±3	mV
	Vo=2.5 V	-	±1	±6	mV
	Vo=3.3 V	-	±3	±8	mV
	Vo=5.0 V	-	±4	±9	mV
	Vo=12 V	-	±10	±25	mV
Line Regulation	Vo=1.5-2.5V	-	±3	±5	mV
	Vo=3.3-5.0V	-	±4	±9	mV
	Vo=12V	-	±9	±18	mV
Regulation Over Temperature	Vo=1.5-1.8 V	-	±6	±14	mV
	Vo=2.5-3.3 V	-	±9	±16	mV
	Vo=5.0 V	-	±15	±30	mV
	Vo=12 V	-	±20	±35	mV
Output Current	Vo=1.5 V	0	-	22	A
	Vo=1.8 V	0	-	20	A
	Vo=2.5 V	0	-	18	A
	Vo=3.3 V	0	-	15	A
	Vo=5.0 V	0	-	12	A
	Vo=12V	0	-	5	A
Current Limit Threshold	Vo=1.5 V	28	34	40	A
	Vo=1.8 V	24	28	34	A
	Vo=2.5 V	22	26	30	A
	Vo=3.3 V	19	22	26	A
	Vo=5.0 V	14	19	24	A
	Vo=12V	5.2	6.5	8.5	A
Short Circuit Surge Transient		-	0.5	1	A2s
Ripple and Noise (rms)	Vo=1.5-1.8 V	-	6	12	mV
	Vo=2.5 V	-	10	20	mV
	Vo=3.3 V	-	12	25	mV
	Vo=5.0 V	-	25	50	mV
	Vo=12V	-	30	55	mV
	Vo=1.5-1.8 V	-	40	70	mV
Ripple and Noise (pk-pk)	Vo=2.5 V	-	45	80	mV
	Vo=3.3 V	-	55	90	mV
	Vo=5.0 V	-	70	120	mV
	Vo=12V	-	90	180	mV
Turn on Time		-	35	70	ms
Overshoot at Turn on		-	0	5	%
Output Capacitance	Vo=1.5	470	-	15000	µF
	Vo=1.8 V-2.5 V	470	-	10000	µF
	Vo=3.3 V	220	-	5600	µF
	Vo=5.0 V	100	-	4700	µF
	Vo=12V	22	-	470	µF

Transient Response							
ΔV 25%~50% of Max Load				-	110	150	mV
Settling Time	Vo=1.5 - 1.8 V			-	110	180	us
ΔV 50%~25% of Max Load				-	110	150	mV
Settling Time				-	110	180	us
ΔV 25%~50% of Max Load				-	150	250	mV
Settling Time	Vo=2.5 - 3.3 V			-	120	200	us
ΔV 50%~25% of Max Load		Test conditions: di/dt = 0.1 A/ μ s, Vin=48 V, with a 1 μ F ceramic capacitor and a Tantalum capacitor (refer to the min. output capacitance above for each output) at the output.		-	150	250	mV
Settling Time			-	120	200	us	
ΔV 25%~50% of Max Load			-	220	350	mV	
Settling Time	Vo=5.0 V		-	120	250	mV	
ΔV 50%~25% of Max Load			-	220	350	mV	
Settling Time			-	120	250	mV	
ΔV 25%~50% of Max Load			-	400	650	mV	
Settling Time	Vo=12 V		-	150	300	mV	
ΔV 50%~25% of Max Load			-	400	650	mV	
Settling Time			-	150	300	mV	

5. GENERAL SPECIFICATIONS

PARAMETER	DESCRIPTION	MIN	TYP	MAX	UNIT
Efficiency	Vo=1.5	82	85	-	%
	Vo=1.8 V-2.5 V	84	87	-	%
	Vo=3.3 V	86	89	-	%
	Vo=5.0 V	87	90	-	%
	Vo=12V	86	89	-	%
Switching Frequency		540	600	660	kHz
Isolation Capacitance		-	3900	-	pF
MTBF	Calculated Per Bell Core SR-332 (IO =80% load, Vin=48 V, Vo=5 V; Ta = 25 °C)		2,770,832		hours
Output Voltage Trim Range	Vo=1.5 - 5.0 V	90	-	110	% Vo
	Vo=12 V	80	-	110	% Vo
Over Temperature Protection		120	-	140	°C
Over Voltage Protection	Test conditions: Vin=48 V, full load and short the feedback optocoupler.	-	130	160	% Vo
Weight		-	13	-	g
Dimensions (L x W x H)	SMT Package		1.3 x 0.9 x 0.364		in
			33.02 x 22.86 x 9.24		mm
	Through Hole Package		1.3 x 0.9 x 0.388		in
			33.02 x 22.86 x 9.85		mm

6. CONTROL SPECIFICATIONS

PARAMETER	DESCRIPTION	MIN	TYP	MAX	UNIT
Signal Low (Unit On)	Active Low	-0.3	-	0.8	V
Signal High (Unit Off)		2.95	-	18	V
Signal Low (Unit Off)	Active High	-0.3	-	0.8	V
Signal High (Unit On)		2.95	-	18	V
Current Sink		0	-	1	mA

7. EFFICIENCY DATA

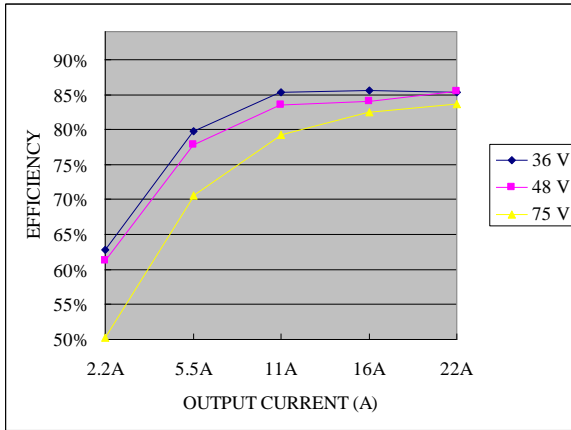

Vo=1.5 V

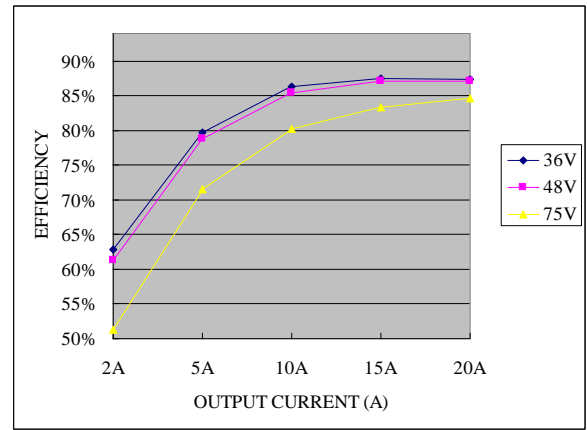

Vo=1.8 V

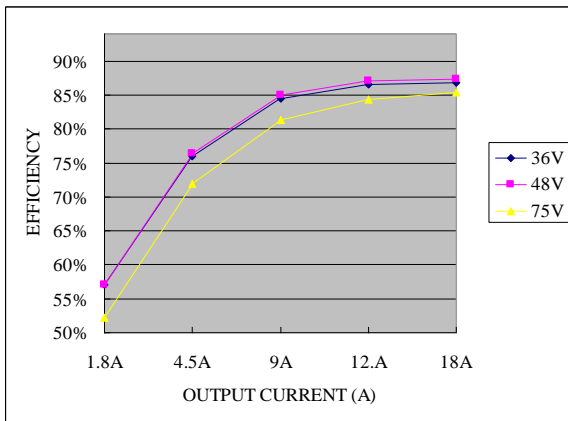

Vo=2.5 V

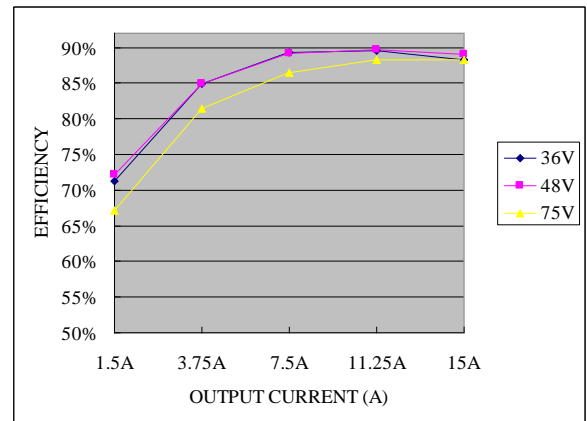

Vo=3.3 V

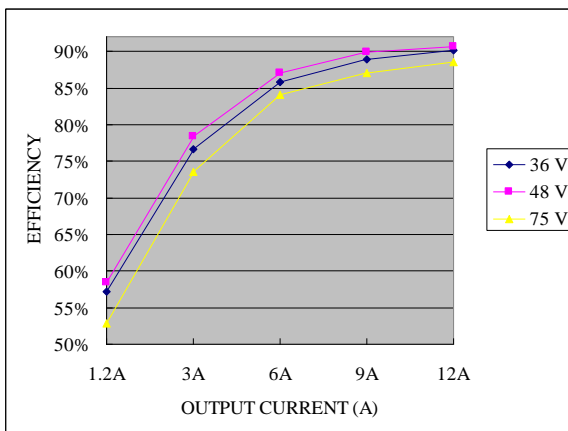

Vo=5 V

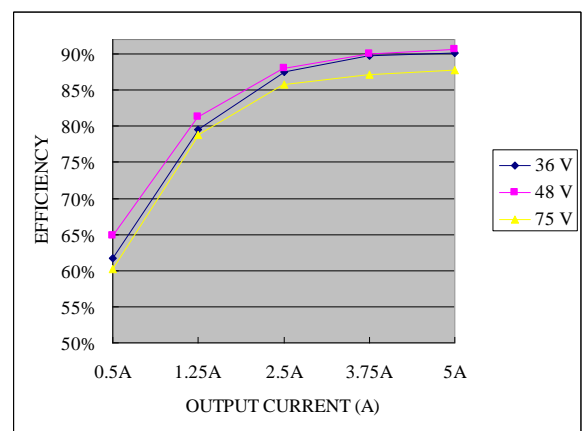

Vo=12 V

8. THERMAL DERATING CURVE

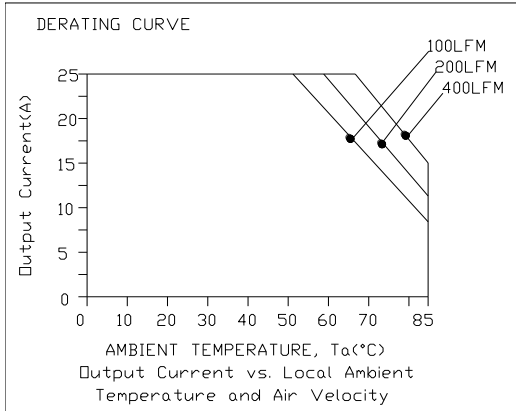

$V_{in}=36\text{ V}, V_o=1.5\text{ V}$

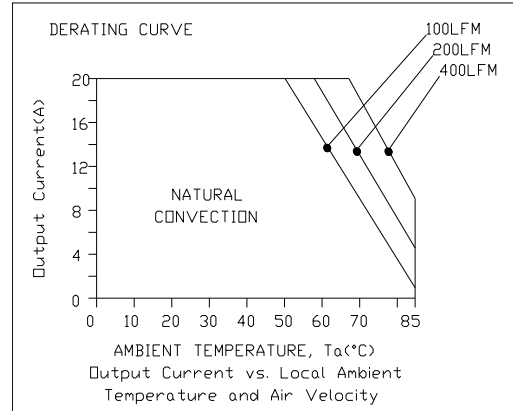

$V_{in}=36\text{ V}, V_o=1.8\text{ V}$

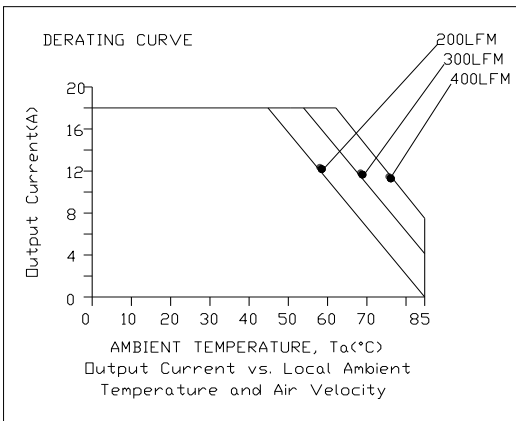

$V_{in}=36\text{ V}, V_o=2.5\text{ V}$

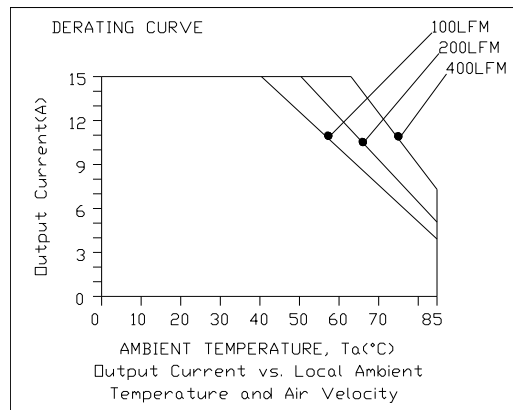

$V_{in}=36\text{ V}, V_o=3.3\text{ V}$

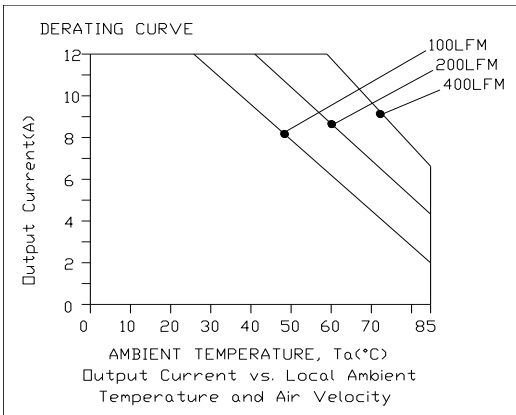

$V_{in}=36\text{ V}, V_o=5.0\text{ V}$

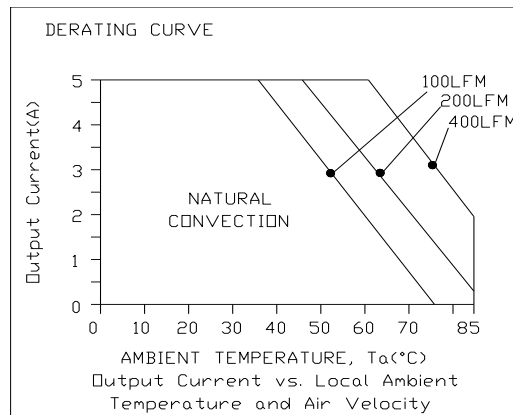

$V_{in}=36\text{ V}, V_o=12\text{ V}$

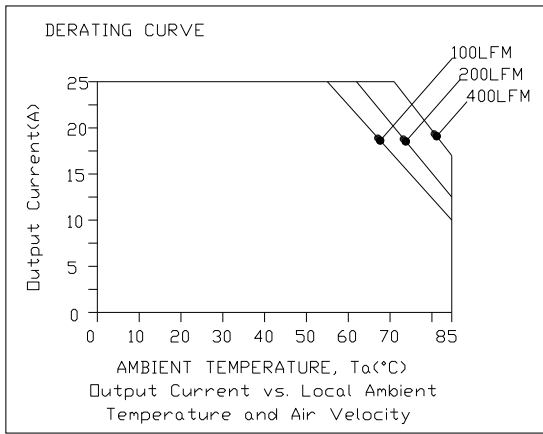

Vin=48 V, Vo=1.5 V

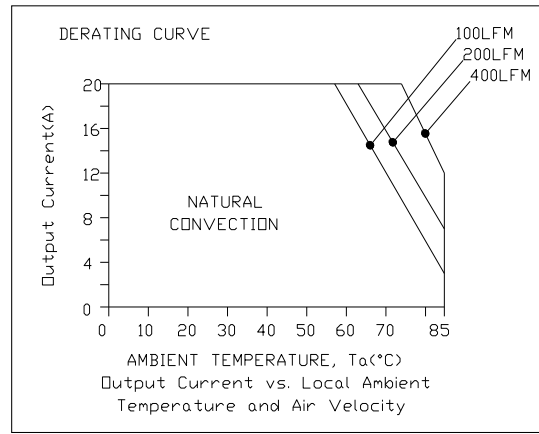

Vin=48 V, Vo=1.8 V

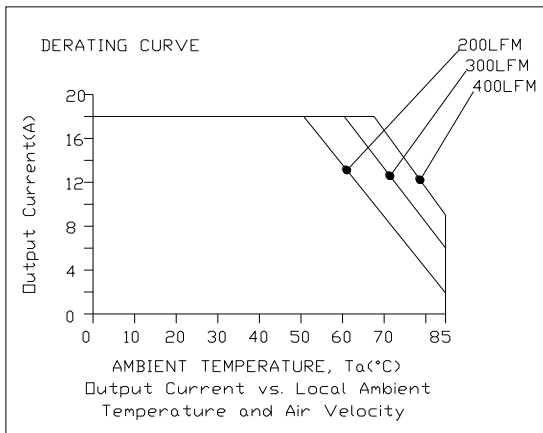

Vin=48 V, Vo=2.5 V

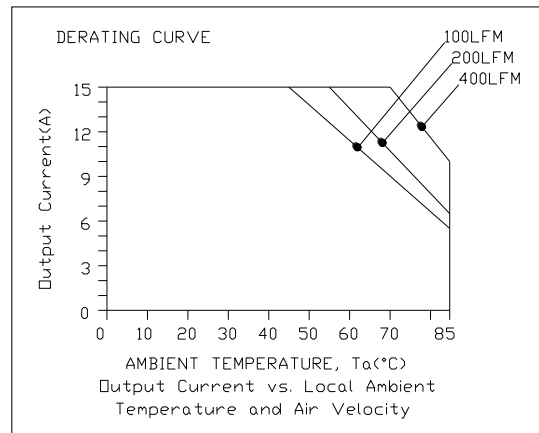

Vin=48 V, Vo=3.3 V

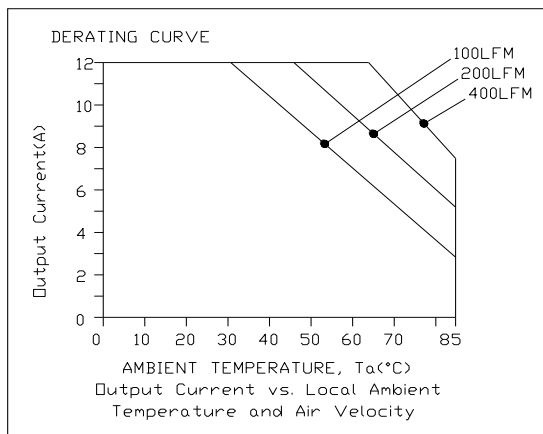

Vin=48 V, Vo=5.0 V

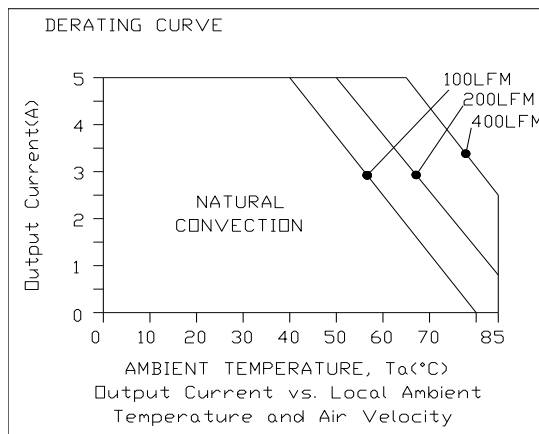

Vin=48 V, Vo=12 V

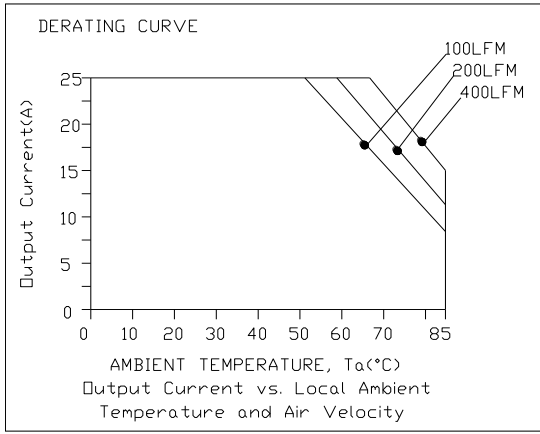

$V_{in}=75\text{ V}, V_o=1.5\text{ V}$

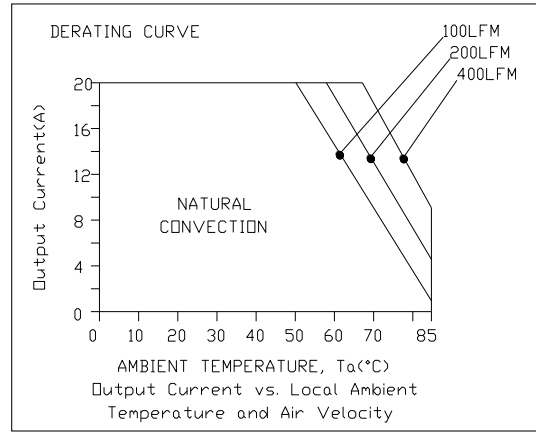

$V_{in}=75\text{ V}, V_o=1.8\text{ V}$

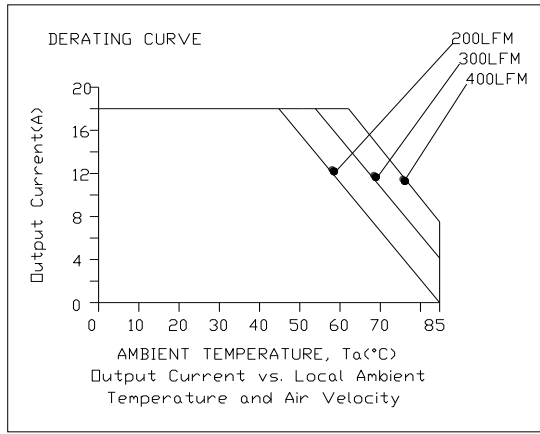

$V_{in}=75\text{ V}, V_o=2.5\text{ V}$

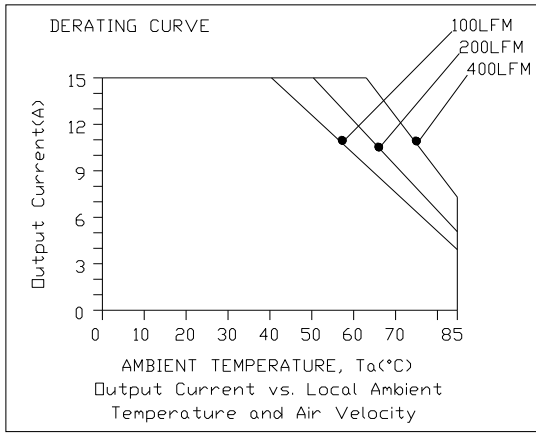

$V_{in}=75\text{ V}, V_o=3.3\text{ V}$

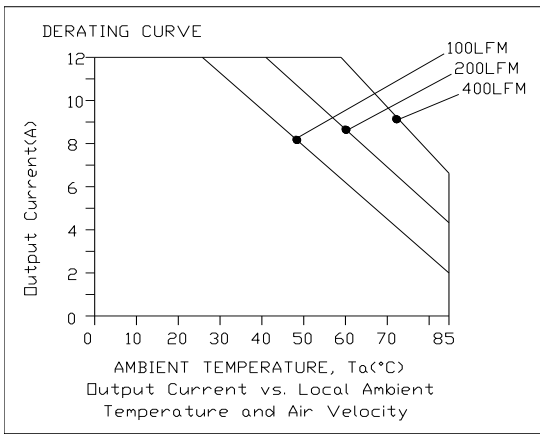

$V_{in}=75\text{ V}, V_o=5.0\text{ V}$

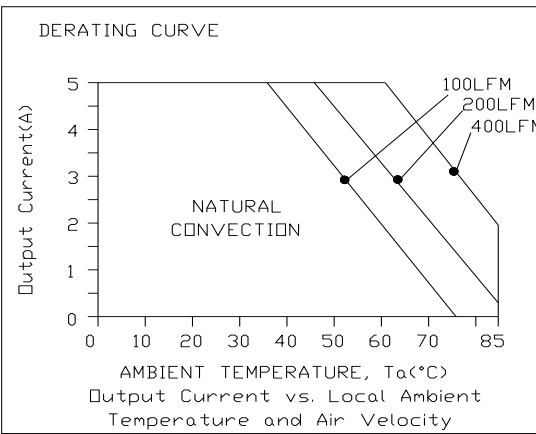

$V_{in}=75\text{ V}, V_o=12\text{ V}$

9. OUTPUT TRIM EQUATIONS

Trim Resistor Calculate

Equations for calculating the trim resistor are shown below (Unit: kΩ). The Trim Down resistor should be connected between the Trim pin and Ground pin. The Trim Up resistor should be connected between the Trim pin and the Vout. Only one of the resistors should be used for any given application.

$$R_{trimdown} = \frac{511}{|\delta|} - 10.22 [k\Omega]$$

$$R_{trimup} = \frac{(100 + \delta) \cdot V_o \cdot 5.11 - 626}{1.225 \cdot \delta} - 10.22 [k\Omega]$$

Note:

$$\delta = \frac{(V_o_{req} - V_o)}{V_o} \times 100 [\%]$$

V_o_{req} = Desired (trimmed) output voltage [V]

V_o = 1.503 V for 1.5 V output; V_o = 1.804 V for 1.8 V output; V_o = 2.505 V for 2.5 V output; V_o = 3.308 V for 3.3 V output; V_o = 5.002 V for 5 V output; V_o = 12.007 V for 12 V output.

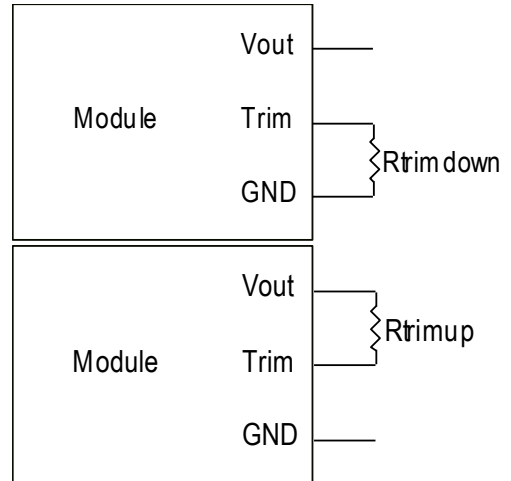

Trim Voltage Calculate

Equations for calculating the external trim voltage are shown below (Unit: V).

$$V_{trim} = \frac{2.45}{V_o} \cdot V_o_{req} - 1.225 [V]$$

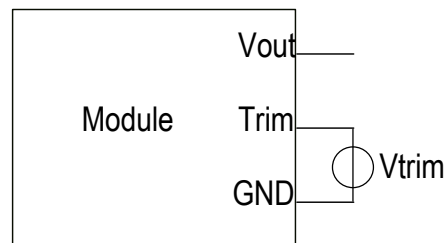

Note:

V_o_{req} = Desired (trimmed) output voltage [V]

V_o = 1.503 V for 1.5 V output; V_o = 1.804 V for 1.8 V output; V_o = 2.505 V for 2.5 V output; V_o = 3.308 V for 3.3 V output; V_o = 5.002 V for 5 V output; V_o = 12.007 V for 12 V output.

10. RIPPLE AND NOISE WAVEFORM

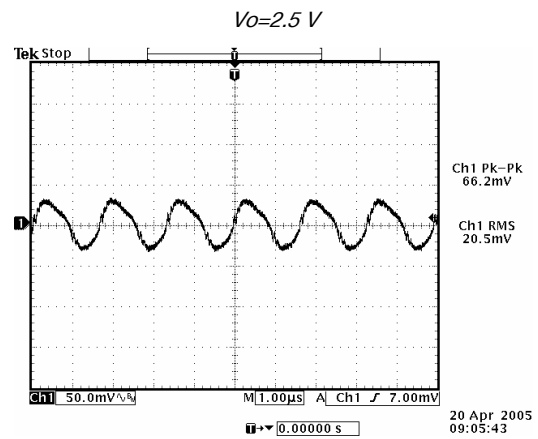
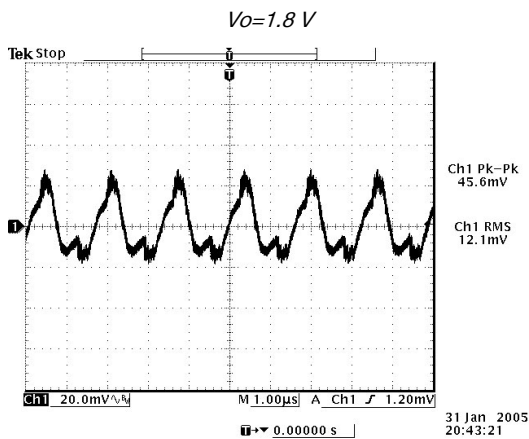
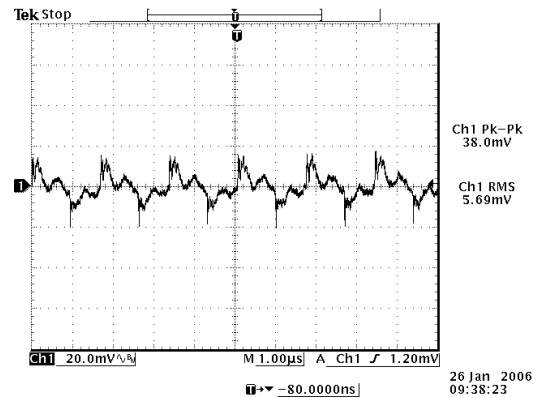
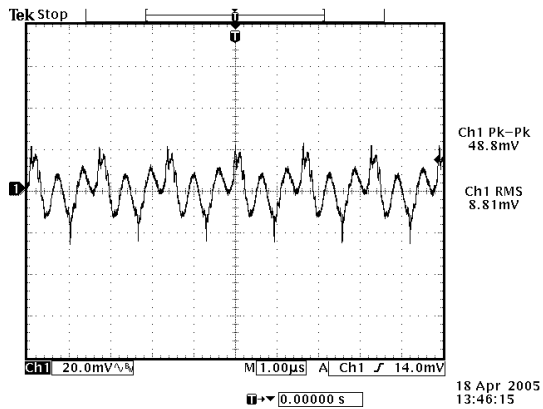

$V_o=3.3\text{ V}$

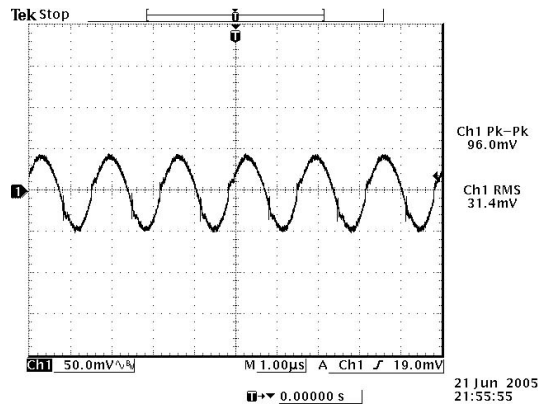

$V_o=5.0\text{ V}$

$V_o=12\text{ V}$

Note: Ripple and Noise at full load, 48 V input, $T_a=25\text{ deg C}$.

- 1) For $V_o=1.8\text{ V}-2.5\text{ V}$, with a 1 μF ceramic capacitor and a 470 μF tantalum cap at the output;
- 2) For $V_o=3.3\text{ V}$, with a 1 μF ceramic capacitor and a 220 μF tantalum cap at the output;
- 3) For $V_o=5.0\text{ V}$, with a 1 μF ceramic capacitor and a 100 μF tantalum cap at the output;
- 4) For $V_o=12\text{ V}$, with a 1 μF ceramic capacitor and a 22 μF tantalum cap at the output.

11. TRANSIENT RESPONSE WAVEFORMS

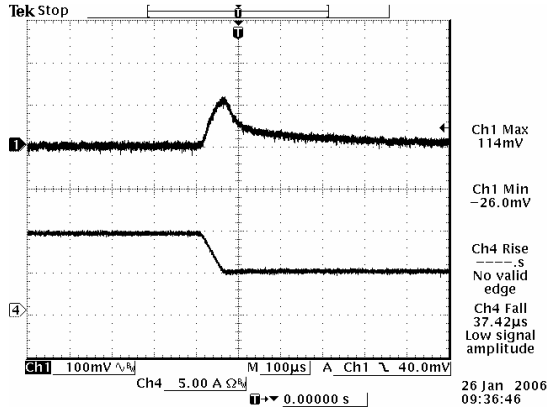

Vo=1.8 V 50% to 25% Load Transients

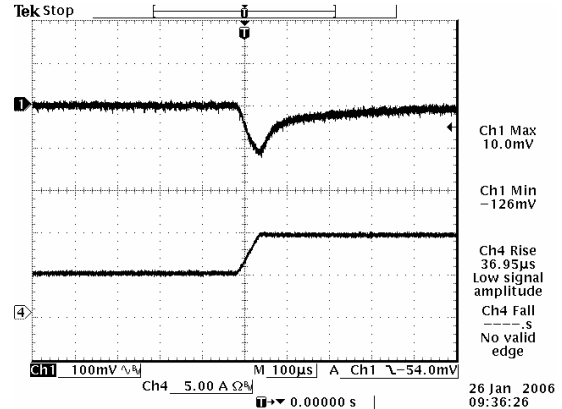

Vo=1.8 V 25% to 50% Load Transients

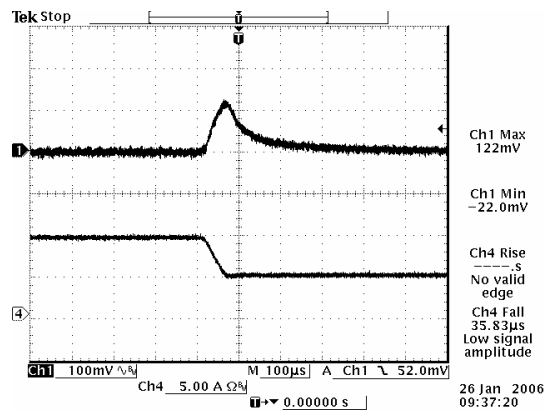

Vo=2.5 V 50% to 25% Load Transients

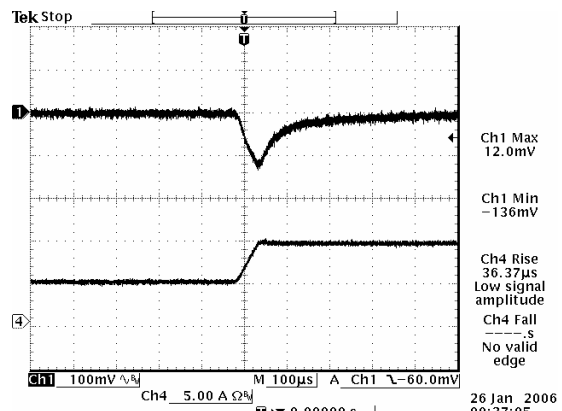

Vo=2.5 V 25% to 50% Load Transients

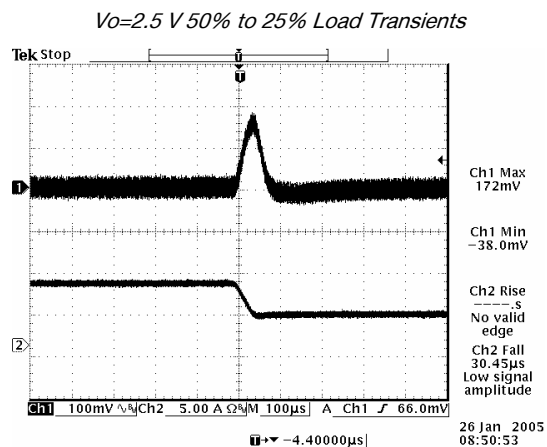

Vo=3.3 V 50% to 25% Load Transients

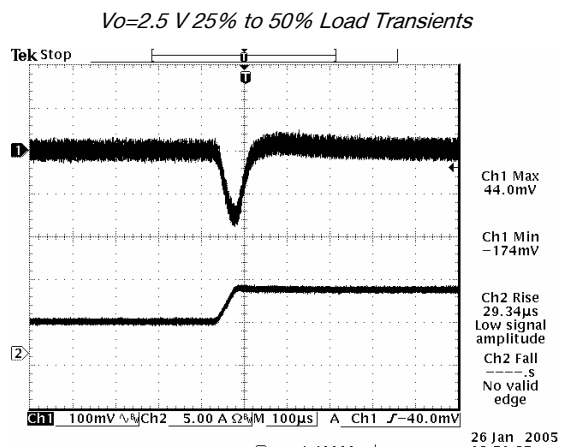

Vo=3.3 V 25% to 50% Load Transients

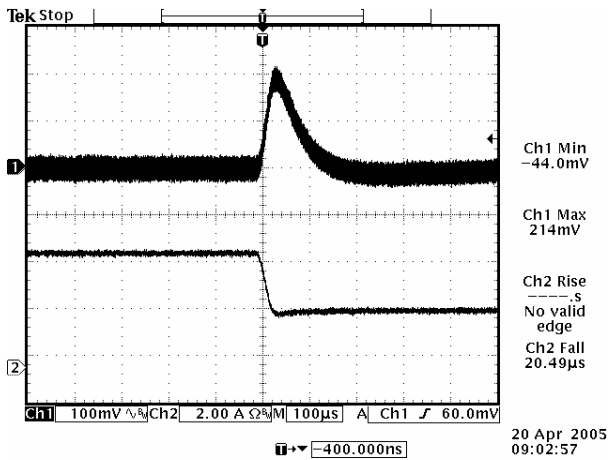

Vo=5 V 50% to 25% Load Transients

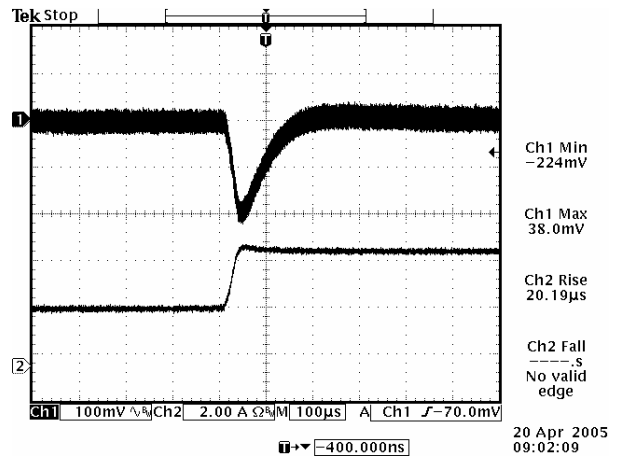

Vo=5 V 25% to 50% Load Transients

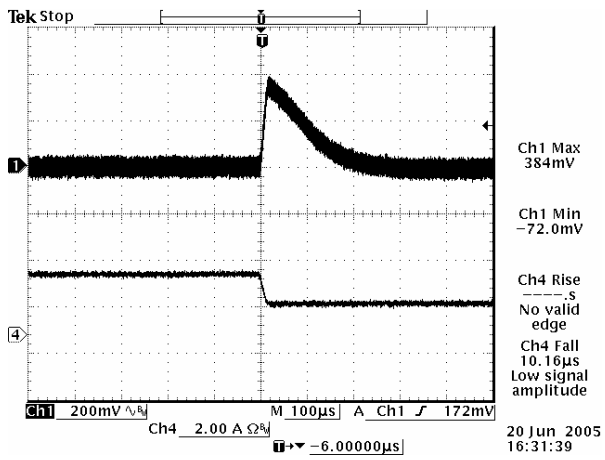

Vo=12 V 50% to 25% Load Transients

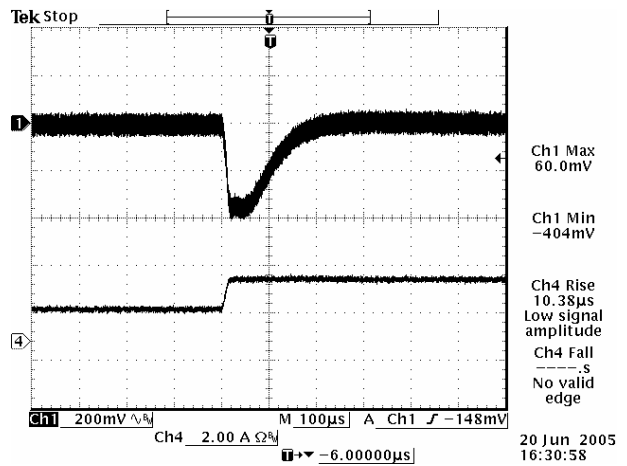

Vo=12 V 25% to 50% Load Transients

Note: Transients Response at Vin=48 V, di/dt=0.1A/uS, Ta=25 deg C.

- 1) For Vo=1.8 V -2.5 V, with a 1 uF ceramic capacitor and a 470 uF tantalum cap at the output;
- 2) For Vo=3.3 V, with a 1 uF ceramic capacitor and a 220 uF tantalum cap at the output;
- 3) For Vo=5.0 V, with a 1 uF ceramic capacitor and a 100 uF tantalum cap at the output;
- 4) For Vo=12 V, with a 1 uF ceramic capacitor and a 22 uF tantalum cap at the output.

12. SOLDERING INFORMATION

The SRSB-50Txxx modules are designed to be compatible with reflow soldering process. The suggested Pb-free solder paste is Sn/Ag/Cu(SAC). The recommended reflow profile using Sn/Ag/Cu solder is shown in the following. Recommended reflow peak temperature is 245°C while the part can withstand peak temperature of 260°C maximum for 10seconds. This profile should be used only as a guideline. Many other factors influence the success of SMT reflow soldering. Since your production environment may differ, please thoroughly review these guidelines with your process engineers.

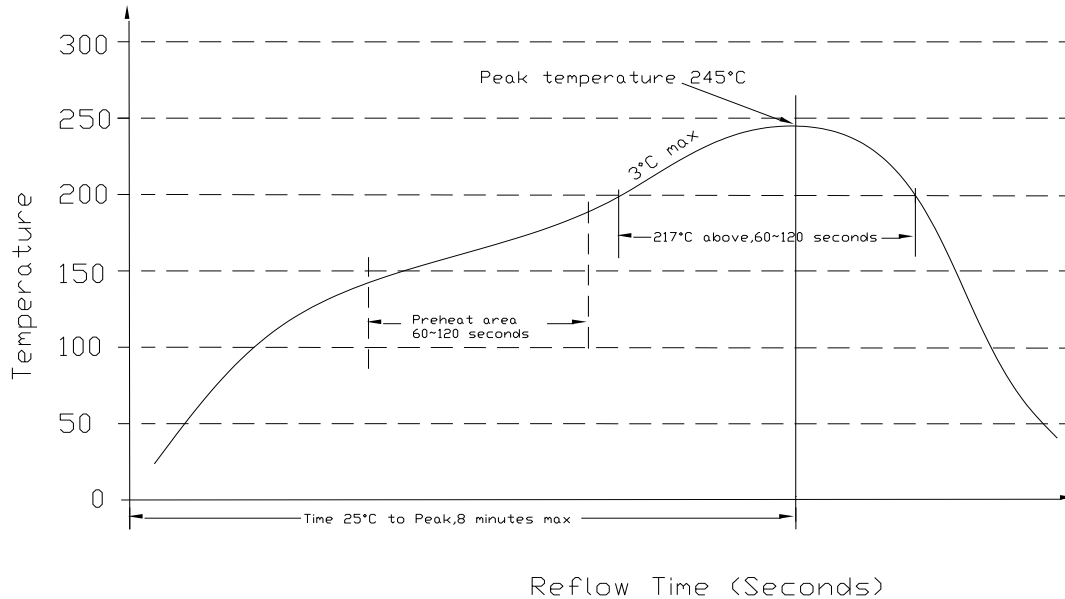

13. MSL RATING

The SRSB-50Txxx modules have a MSL rating of 3.

14. STORAGE AND HANDLING

The SRSB-50Txxx modules are designed to be compatible with J-STD-033 Rev:A (Handling, Packing, Shipping and Use of Moisture /Reflow Sensitive surface Mount devices). Moisture barrier bags (MBB) with desiccant are applied. The recommended storage environment and handling procedure is detailed in J-STD-033.

15. PRE-BAKING

This component has been designed, handled, and packaged ready for pb-free reflow soldering. If the assembly shop follows J-STD-033 guidelines, no pre-bake of this component is required before being reflowed to a PCB. However, if the J-STD-033 guidelines are not followed by the assembler, Bel recommends that the modules should be pre-baked @ 120~125°C for a minimum of 4 hours (preferably 24 hours) before reflow soldering.

16. MECHANICAL DIMENSIONS

SRSB-50TxxxG/H

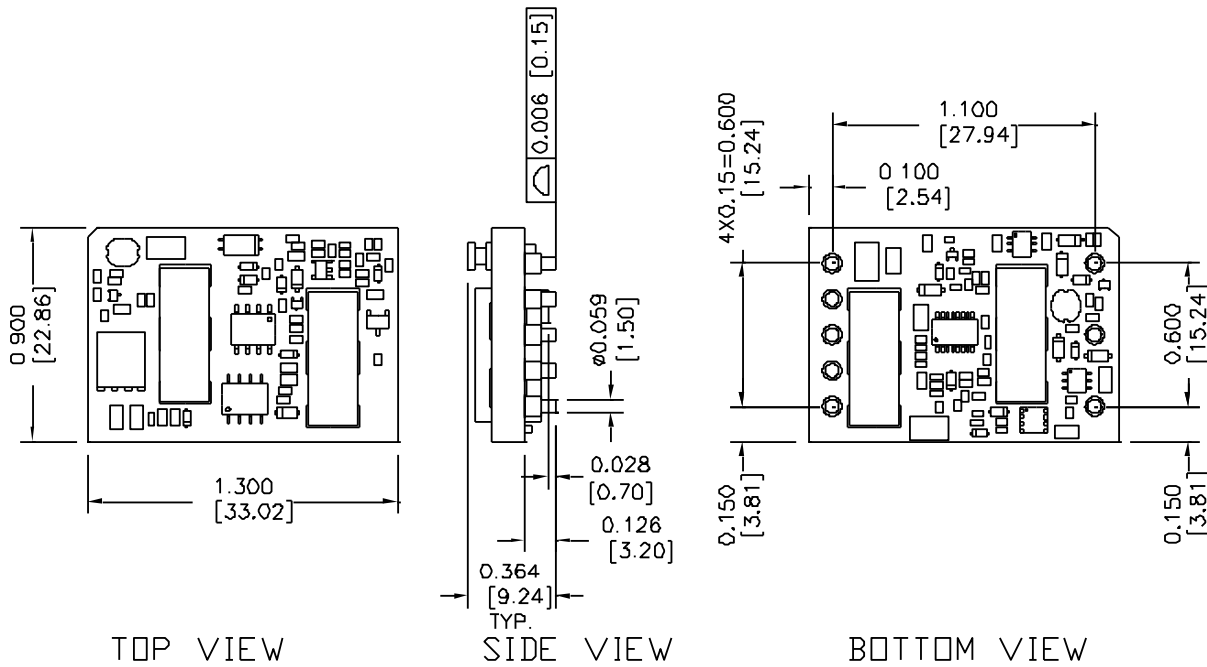

RECOMMENDED PCB PAD LAYOUT

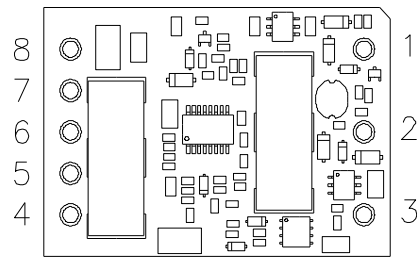
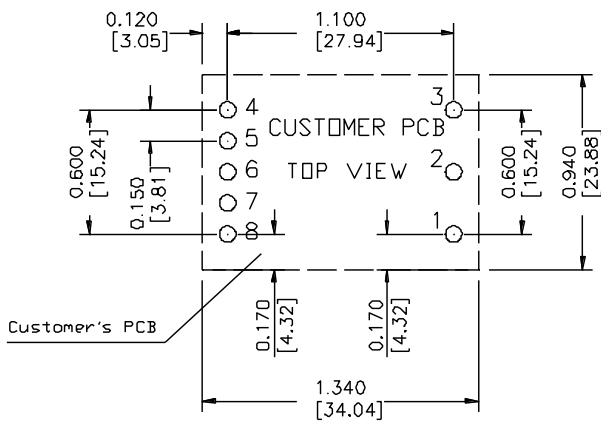

PIN CONNECTIONS

PIN	FUNCTION
1	Vin (+)
2	Remote On/Off
3	Vin (-)
4	Vout-
5	SENSE(-)
6	TRIM
7	SENSE(+)
8	Vout(+)

Recommended Surface Mount Pads
 Min. $\phi 0.080''$ [2.03]
 Max. $\phi 0.092''$ [2.34]

Note:

- 1) All Pins: Material - Copper Alloy;
 Finish - 3 micro inches minimum Gold over 50 micro inches minimum Nickel plate.
- 2) Undimensioned components are shown for visual reference only.
- 3) All dimensions in inches; Tolerances: x.xx +/-0.02[0.50], x.xxx +/-0.010[0.25] unless otherwise stated

SRSB-50TxxxR/S

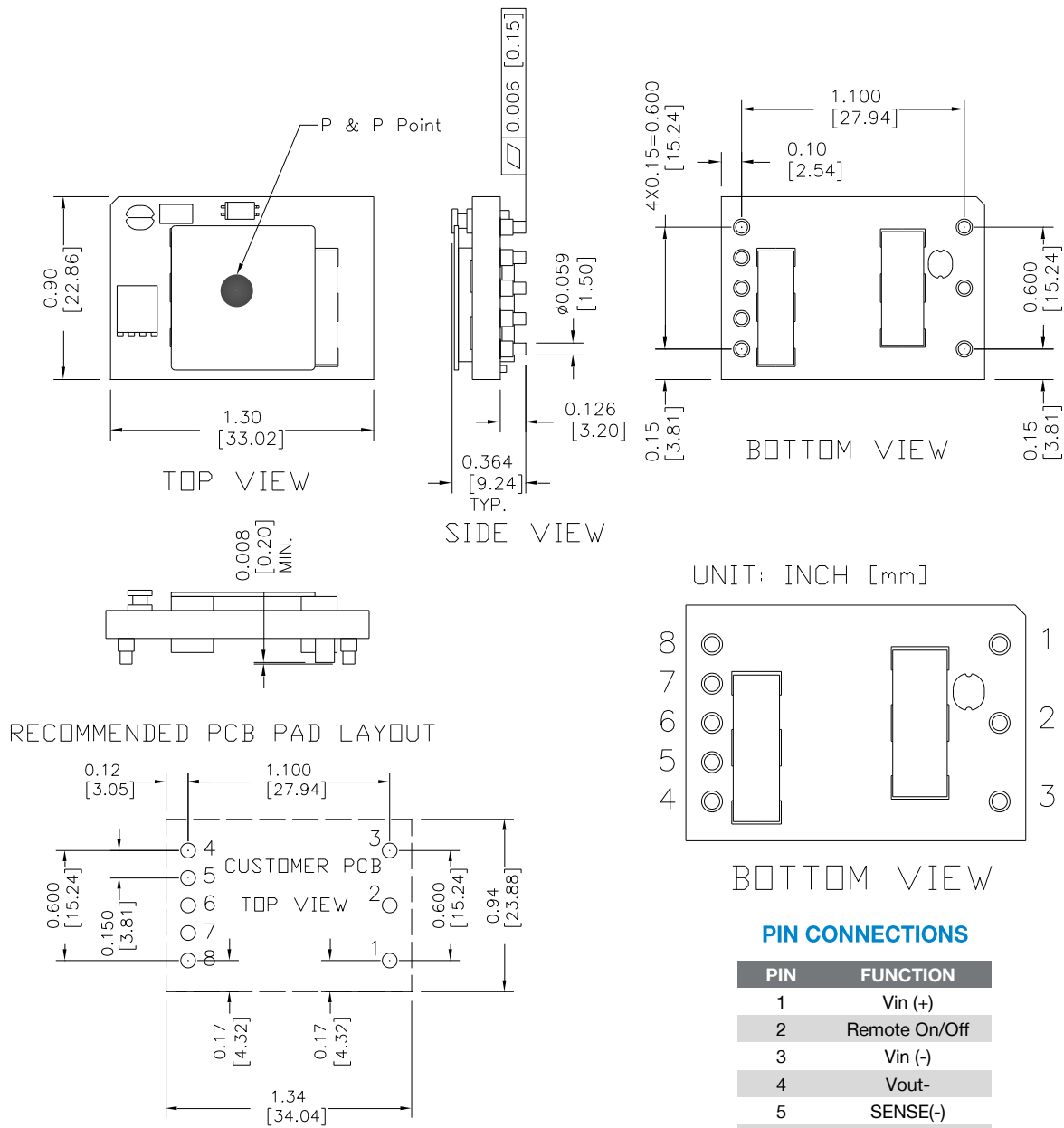

UNIT: INCH [mm]

PIN CONNECTIONS

PIN	FUNCTION
1	Vin (+)
2	Remote On/Off
3	Vin (-)
4	Vout-
5	SENSE(-)
6	TRIM
7	SENSE(+)
8	Vout(+)

Recommended Surface Mount Pads
 Min. $\phi 0.080$ " [2.03]
 Max. $\phi 0.092$ " [2.34]

Note: These parts are not however compatible with the higher temperatures associated with lead free solder processes and must be soldered using a reflow profile with a peak temperature of no more than 245 °C.

- Note:**
- 1) All Pins: Material - Copper Alloy;
Finish - 3 micro inches minimum Gold over 50 micro inches minimum Nickel plate.
 - 2) Undimensioned components are shown for visual reference only.
 - 3) All dimensions in inches; Tolerances: x.xx +/-0.02 in. x.xxx +/-0.010 in. unless otherwise stated.



Asia-Pacific +86 755 298 85888 Europe, Middle East +353 61 225 977 North America +1 408 785 5200

0RSB-50TxxxG/H

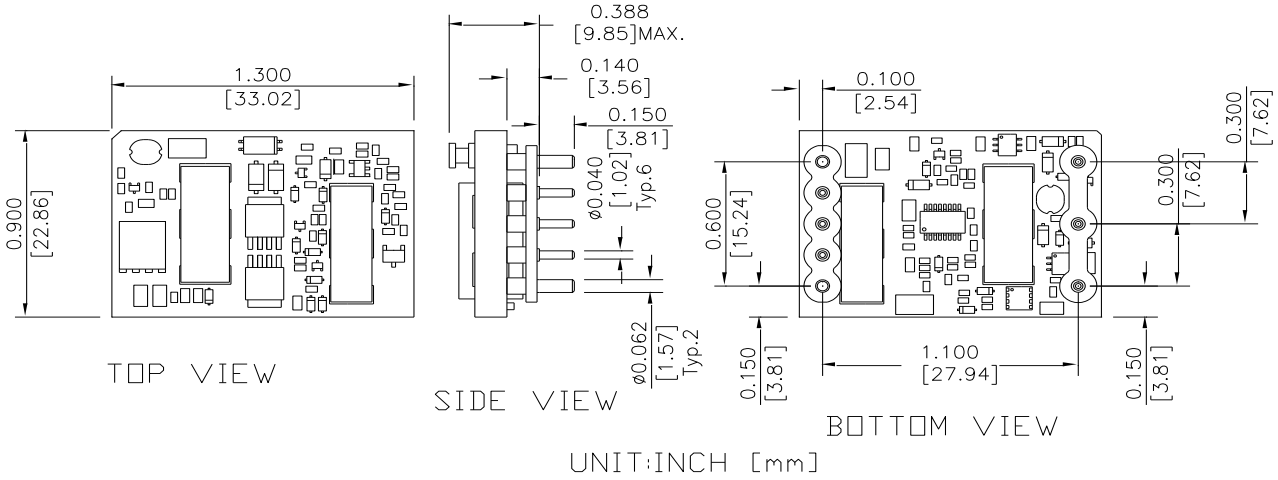

RECOMMENDED PCB PAD LAYOUT

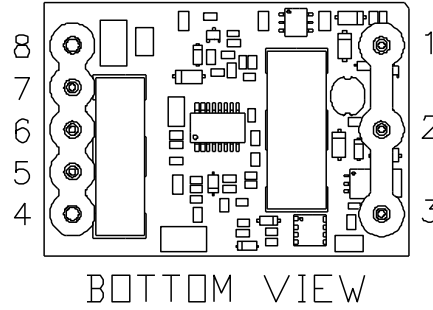
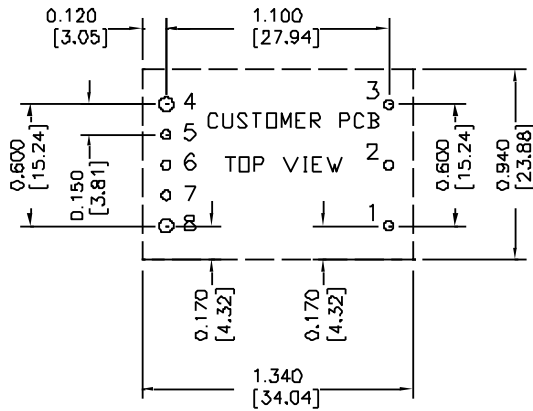

PIN CONNECTIONS

PIN	FUNCTION
1	Vin (+)
2	Remote On/Off
3	Vin (-)
4	Vout-
5	SENSE(-)
6	TRIM
7	SENSE(+)
8	Vout(+)

Note: These parts are not however compatible with the higher temperatures associated with lead free solder processes and must be soldered using a reflow profile with a peak temperature of no more than 245 °C.

Note:

- 1) All Pins: Material - Copper Alloy;
 Finish - 3 micro inches minimum Gold over 50 micro inches minimum Nickel plate.
- 2) Undimensioned components are shown for visual reference only.
- 3) All dimensions in inches; Tolerances: x.xx +/-0.02 in. x.xxx +/-0.010 in. unless otherwise stated.

17. PACKAGING INFORMATION

SRSB-50TxxxR/S

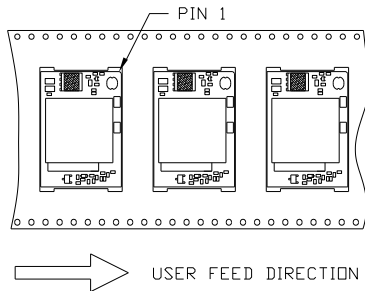

ORIENTATION OF COMPONENT INSIDE POCKET

TAPE WIDTH	56mm
POCKET PITCH	32mm
QUANTITY OF COMPONENTS PER REEL	160
PLASTIC REEL OUTER DIAMETER	13 INCHES
PLASTIC REEL HUB DIAMETER	4 INCHES
COMPLY WITH EIA 481-2-A	

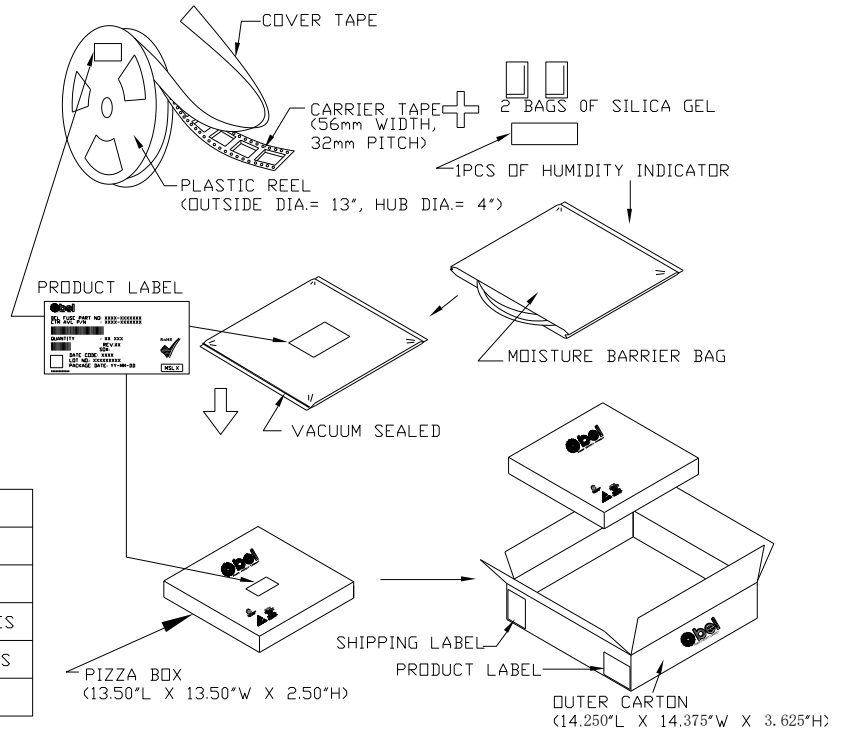

xRSB-50TxxxG/H

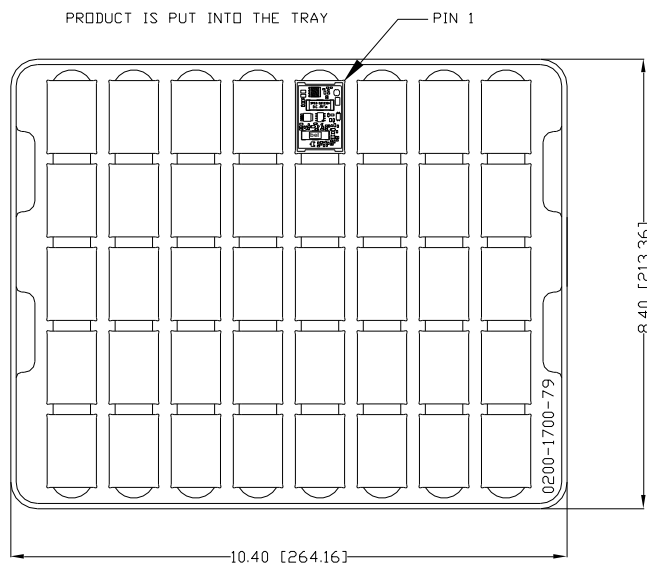
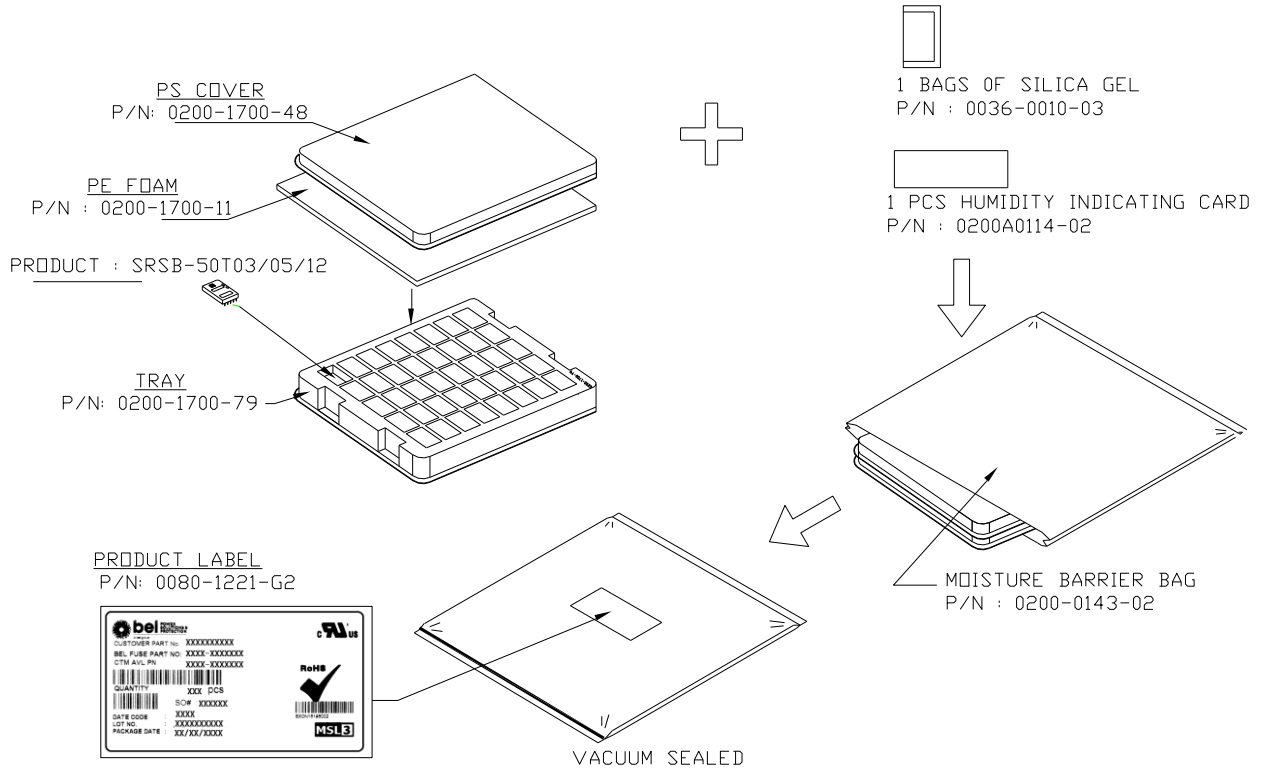

REVISION HISTORY

DATE	REVISION	CHANGES DETAIL	APPROVAL
2010-04-12	F	Update the 0RSB-50T series product height from 0.378" to 0.388".	Jack Fan
2010-11-17	G	Add Derating Curve under 36V _{in} , 75V _{in} at 12V output.	JZ Wang
2011-05-17	H	Add trim equation for external voltage trim.	JZ Wang
2011-08-25	I	Update the reflow solder temperature.	HL
2011-11-01	J	Add thermal derating curve for 36V _{in} and 75V _{in} .	JZ Wang
2012-07-04	K	Adding the 7C-III compliance suffix statement.	JZ Wang
2016-09-12	AL	Update form.	Jessica Yan
2017-03-03	AM	Update part number explanation, mechanical dimensions, packaging information	Jessica Yan

For more information on these products consult: tech.support@psbel.com

NUCLEAR AND MEDICAL APPLICATIONS - Products are not designed or intended for use as critical components in life support systems, equipment used in hazardous environments, or nuclear control systems.

TECHNICAL REVISIONS - The appearance of products, including safety agency certifications pictured on labels, may change depending on the date manufactured. Specifications are subject to change without notice.



Asia-Pacific
+86 755 298 85888

Europe, Middle East
+353 61 225 977

North America
+1 408 785 5200

X-ON Electronics

Largest Supplier of Electrical and Electronic Components

Click to view similar products for [Isolated DC/DC Converters](#) category:

Click to view products by [Bel Fuse](#) manufacturer:

Other Similar products are found below :

[ESM6D044440C05AAQ](#) [FMD15.24G](#) [PSL486-7LR](#) [PSR152.5-7IR](#) [Q48T30020-NBB0](#) [AVO240-48S12B-6L](#) [AVO250-48S28B-6L](#) [NAN-0505](#) [HW-L16D](#) [JAHW100Y1](#) [217-1617-001](#) [22827](#) [SPB05C-12](#) [SQ24S15033-PS0S](#) [18952](#) [19-130041](#) [CE-1003](#) [CE-1004](#) [GQ2541-7R](#) [PSE1000DCDC-12V](#) [RDS180245](#) [MAU228](#) [419-2065-201](#) [449-2075-101](#) [TME 0303S](#) [TME 0505S](#) [TME 1205S](#) [TME 1212S](#) [TME 2405S](#) [TME 2412S](#) [V300C24C150BG](#) [419-2062-200](#) [419-2063-401](#) [419-2067-101](#) [419-2067-501](#) [419-2068-001](#) [DCG40-5G](#) [DFC15U48D15](#) [449-2067-000](#) [XGS-0512](#) [XGS-1205](#) [XGS-1212](#) [XGS-2412](#) [XGS-2415](#) [XKS-1215](#) [033456](#) [NCT1000N040R050B](#) [SPB05B-15](#) [SPB05C-15](#) [TME 0509S](#)