

T0-277

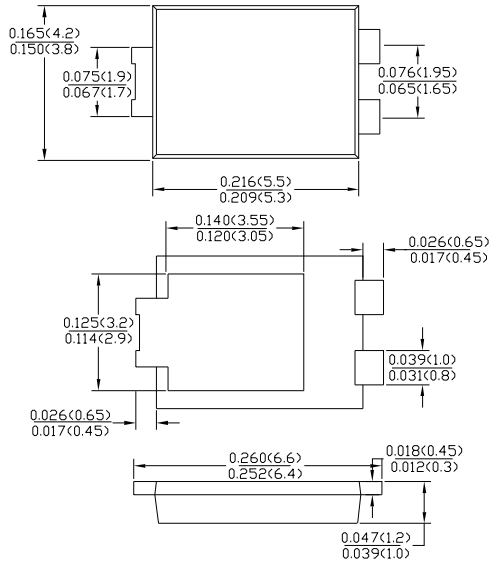

Dimensions inches and (millimeters)

Features

- Schottky Barrier Chip
- High Thermal Reliability
- Patented Super Barrier Rectifier Technology
- High Forward Surge Capability
- Ultra Low Power Loss, High Efficiency
- Excellent High Temperature Stability

Mechanical Data

- Case: T0-277 Molded Plastic
- Terminals: Plated Leads Solderable per MIL-STD-202, Method 208
- Polarity: Cathode Band
- Weight: 0.093 grams (approx.)
- Mounting Position: Any
- Marking: Type Number
- Lead Free: For RoHS/Lead Free Version

Maximum Ratings and Electrical Characteristics @ $T_A=25^{\circ}\text{C}$ unless otherwise specified

Single Phase, half wave, 60Hz, resistive or inductive load.
For capacitive load, derate current by 20%.

Characteristic	Symbol	SL1545	Unit
Peak Repetitive Reverse Voltage Working Peak Reverse Voltage DC Blocking Voltage	V_{RRM} V_{RWM} V_R	45	V
RMS Reverse Voltage	$V_{R(RMS)}$	28	V
Average Rectified Output Current (Note 1) @ $T_L = 90^{\circ}\text{C}$	I_O	15.0	A
Non-Repetitive Peak Forward Surge Current 8.3ms Single half sine-wave superimposed on rated load (JEDEC Method) @ $T_L = 75^{\circ}\text{C}$	I_{FSM}	275	A
Forward Voltage Drop @ $I_F = 15\text{A}, T_j = 25^{\circ}\text{C}$	V_{FM}	0.47	V
Peak Reverse Current @ $V_F = 45\text{V}, T_j = 25^{\circ}\text{C}$ At Rated DC Blocking Voltage @ $V_F = 45\text{V}, T_j = 100^{\circ}\text{C}$	I_{RM}	0.3 15	mA
Typical Thermal Resistance Junction to Ambient	$R_{\theta JA}$ $R_{\theta JL}$	80 15	$^{\circ}\text{C/W}$
Operating Temperature Range	T_j	-55 to +150	$^{\circ}\text{C}$
Storage Temperature Range	T_{STG}	-55 to +150	$^{\circ}\text{C}$

Note: 1. Valid provided that leads are kept at ambient temperature at a distance of 9.5mm from the case.
2. FR-4 PCB, 2oz. Copper, minimum recommended pad layout .
3. Polyimide PCB, 2oz. Copper. Cathode pad dimensions 18.8mm x 14.4mm. Anode pad dimensions 5.6mm x 14.4mm.

15.0A SCHOTTKY BARRIER RECTIFIER SL1545

Fig.1 - Forward Current Derating Curve

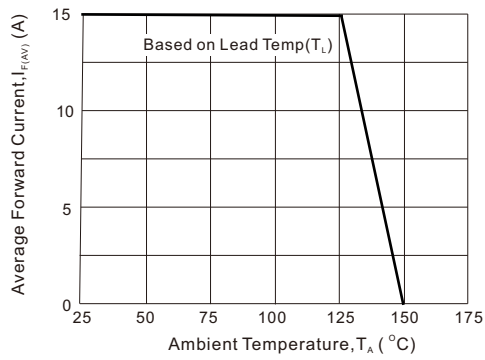

Fig2 : Instantaneous Forward Voltage

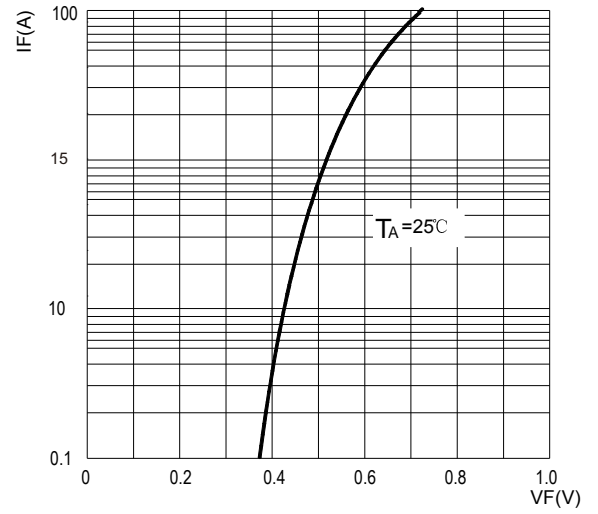

Fig3: Surge Forward Current Capadility

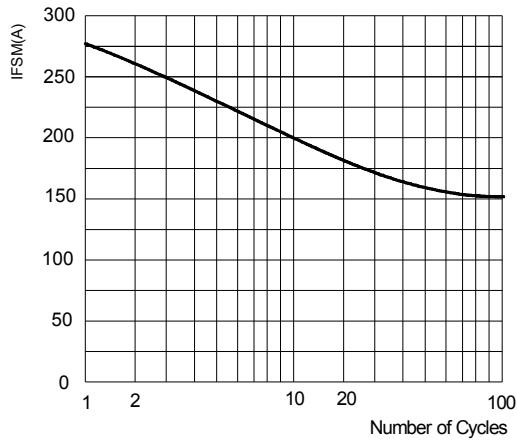
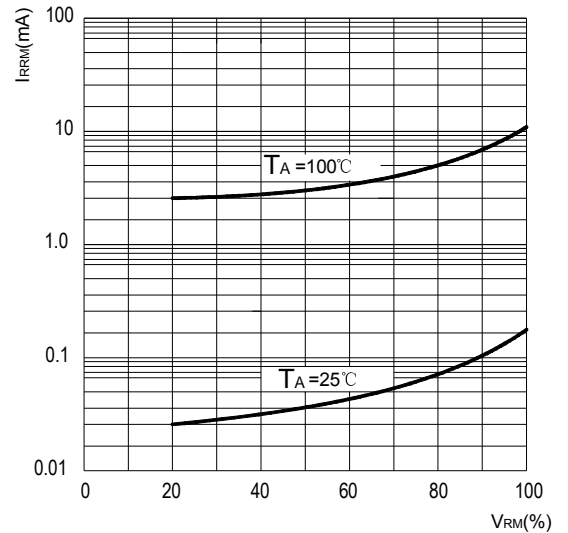

Fig4: Typical Reverse Characteristics



X-ON Electronics

Largest Supplier of Electrical and Electronic Components

Click to view similar products for [Schottky Diodes & Rectifiers](#) category:

Click to view products by [Microdiode Electronics](#) manufacturer:

Other Similar products are found below :

[CUS06\(TE85L,Q,M\)](#) [D1FH3-5063](#) [MBR0530L-TP](#) [MBR10100CT-BP](#) [MBR30H100MFST1G](#) [MMBD301M3T5G](#) [PMAD1103-LF](#)
[PMAD1108-LF](#) [RB160M-50TR](#) [RB520S-30](#) [RB551V-30](#) [DD350N18K](#) [DZ435N40K](#) [DZ600N16K](#) [BAS16E6433HTMA1](#) [BAS 3010S-](#)
[02LRH E6327](#) [BAT 54-02LRH E6327](#) [IDL02G65C5XUMA1](#) [NSR05F40QNXT5G](#) [JANS1N6640](#) [SB07-03C-TB-H](#) [SB1003M3-TL-W](#)
[SBAT54CWT1G](#) [SBM30-03-TR-E](#) [SK32A-LTP](#) [SK33A-TP](#) [SK34A-TP](#) [SK34B-TP](#) [SMD1200PL-TP](#) [ACDBN160-HF](#) [SS3003CH-TL-E](#)
[STPS30S45CW](#) [PDS3100Q-7](#) [GA01SHT18](#) [CRS10I30A\(TE85L,QM\)](#) [MBR1240MFST1G](#) [MBRB30H30CT-1G](#) [BAS28E6433HTMA1](#) [BAS](#)
[70-02L E6327](#) [HSB123JTR-E](#) [JANTX1N5712-1](#) [VS-STPS40L45CW-N3](#) [DD350N12K](#) [SB007-03C-TB-E](#) [SB10015M-TL-E](#) [SB1003M3-TL-](#)
[E](#) [SK110-LTP](#) [SK154-TP](#) [SK32A-TP](#) [SK33B-TP](#)