

80V 1A Switching Current Buck PFM LED Constant Current Driver**XL8004****Features**

- Wide 24V to 80V Input Voltage Range
- 0.2V current sense voltage reference.
- Directly drive 3~8 series LED.
- Excellent line and load regulation.
- High efficiency up to 96%.
- Internal optimize power HV-MOSFET.
- Built in thermal shutdown function.
- Built in UVLO function.
- Built in current limiting function.
- Built in LED open & short protection.
- Built in soft-start circuit.
- Available in TO252-5L package.

Applications

- EBIKE LED Lighting
- LED Lighting & LED LAMP
- General purpose lighting

General Description

The XL8004 is a monolithic high voltage switching regulator with PFM that is specifically designed to operate from a 24V~80V DC supply.

The XL8004 is a high efficiency LED driver switching regulator. The LED string is driven at DC constant current rather than constant voltage, thus providing constant current output and enhanced reliability.

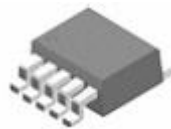

Figure1. Package Type of XL8004

80V 1A Switching Current Buck PFM LED Constant Current Driver **XL8004**

Pin Configurations

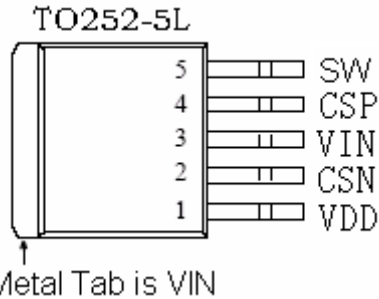

Figure2. Pin Configuration of XL8004 (Top View)

Table 1 Pin Description

Pin Number	Pin Name	Description
1	VDD	The chip supply voltage.
2	CSN	Current Sense Negative Terminal.
3	VIN	Input high voltage Pin. (Operation voltage 24V~ 80V)
4	CSP	Current Sense Positive Terminal.
5	SW	Output Switching Pin.

Function Block

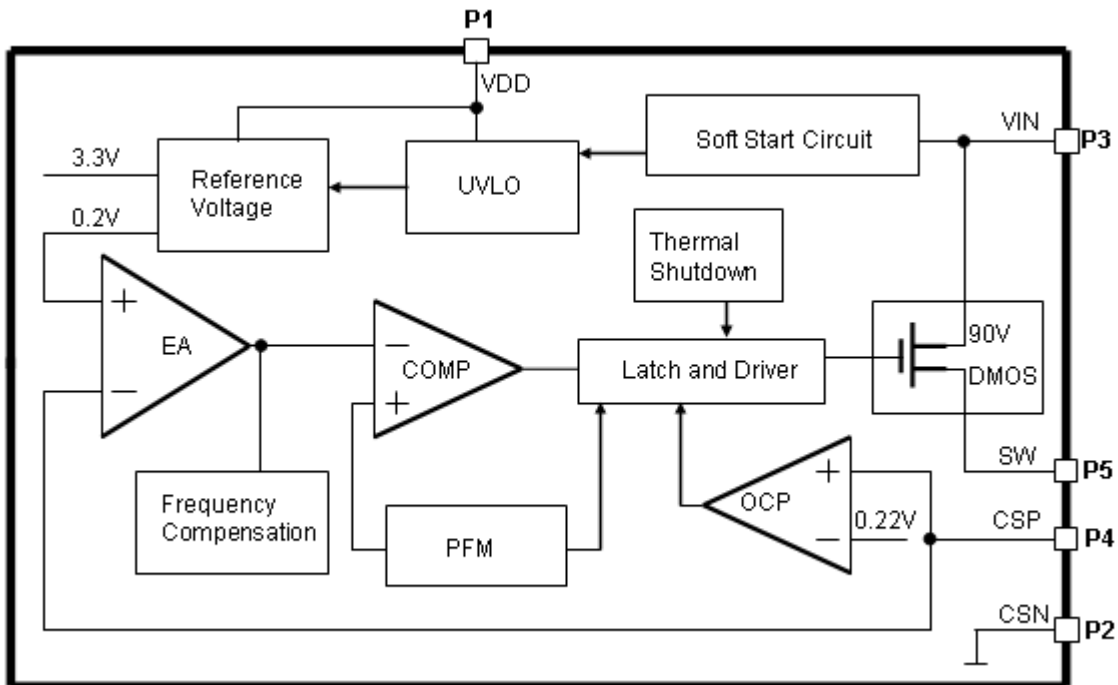
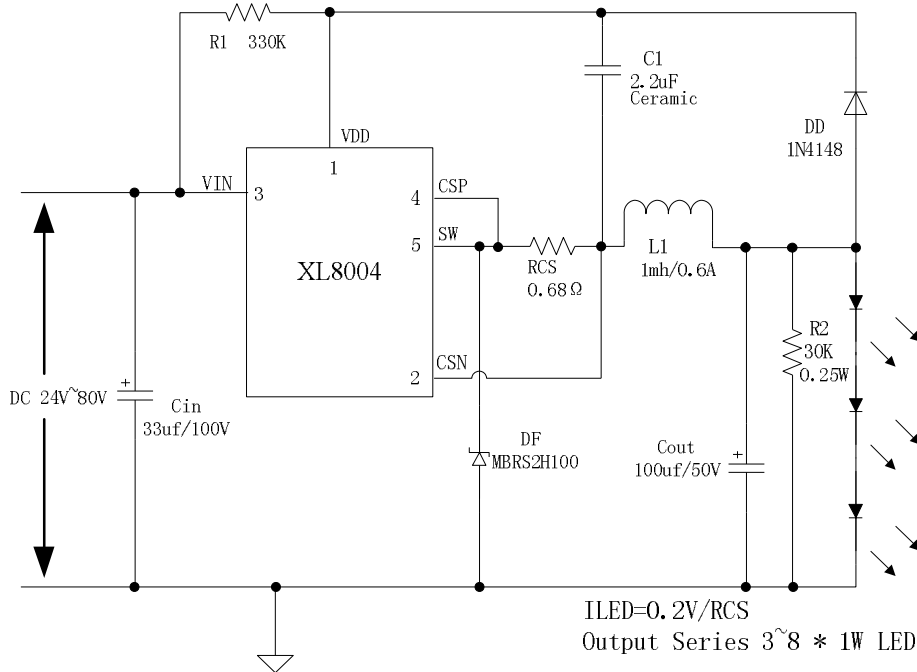

Figure3. Function Block Diagram of XL8004

80V 1A Switching Current Buck PFM LED Constant Current Driver

XL8004

Typical application circuit



- [1] Input DC 24V~80V.
- [2] Output Constant Current Drive Series 3~8 * 1W LED.
- [3] Support Output LED Open & Short Protection.

Figure4. XL8004 Typical Application (3W~8W LED lamp)

Ordering Information

Order Information	Marking ID	Package Type	Packing Type Supplied As
XL8004E1	XL8004E1	TO252-5L	2500 Units on Tape & Reel

XLSEMI Pb-free products, as designated with “E1” suffix in the par number, are RoHS compliant.

Absolute Maximum Ratings (Note1)

Parameter	Symbol	Value	Unit
Input Voltage	V _{in}	-0.3 to 90	V
Power Dissipation	P _D	Internally limited	mW
Thermal Resistance (TO252-5L) (Junction to Ambient, No Heatsink, Free Air)	R _{JA}	50	°C/W
Operating Junction Temperature	T _J	-40 to 125	°C
Storage Temperature	T _{STG}	-65 to 150	°C
Lead Temperature (Soldering, 10 sec)	T _{LEAD}	260	°C
ESD (HBM)		3000	V

80V 1A Switching Current Buck PFM LED Constant Current Driver	XL8004
----------------------------------------------------------------------	---------------

Note1: Stresses greater than those listed under Maximum Ratings may cause permanent damage to the device. This is a stress rating only and functional operation of the device at these or any other conditions above those indicated in the operation is not implied. Exposure to absolute maximum rating conditions for extended periods may affect reliability.

XL8004 Electrical Characteristics

T_a = 25°C; unless otherwise specified. Reference test circuit figure4

Symbol	Parameter	Test Condition	Min.	Typ.	Max.	Unit
VCSP	CSP Voltage	VIN = 24V to 80V, Iled=0.3A, Pout=8W	190	200	210	mV
Efficiency	η	VIN=48V, Iled=0.3A, Pout=8W	-	94.9	-	%
Efficiency	η	VIN=60V, Iled=0.3A, Pout=8W	-	94.6	-	%
Efficiency	η	VIN=72V, Iled=0.3A, Pout=8W	-	92.4	-	%

Electrical Characteristics (DC Parameters)

Parameters	Symbol	Test Condition	Min.	Typ.	Max.	Unit
Input operation voltage	VIN		24		80	V
Switching Frequency	Fosc	Figure4 (8*1W) VIN=48V	47.8	59.7	71.6	KHz
Switching Frequency	Fosc	Figure4 (8*1W) VIN=60V	56.5	70.6	84.7	KHz
Switching Frequency	Fosc	Figure4 (8*1W) VIN=72V	61.2	76.4	91.6	KHz
Output LED open voltage	Vopen	Figure4 VIN=72V			36	V
DMOS Drain-Source Breakdown Voltage	VBRDS	VGS=0V, IDS=250uA	90			V
DMOS Drain-Source on resistor	RDS(on)	IDS=0.5A, VGS=10V		0.1	0.15	Ohm
Thermal Shutdown	OTP	Tj		165		°C
Thermal Shutdown Window				25		°C

80V 1A Switching Current Buck PFM LED Constant Current Driver XL8004

[1] Typical application circuit (3W ~ 8W)

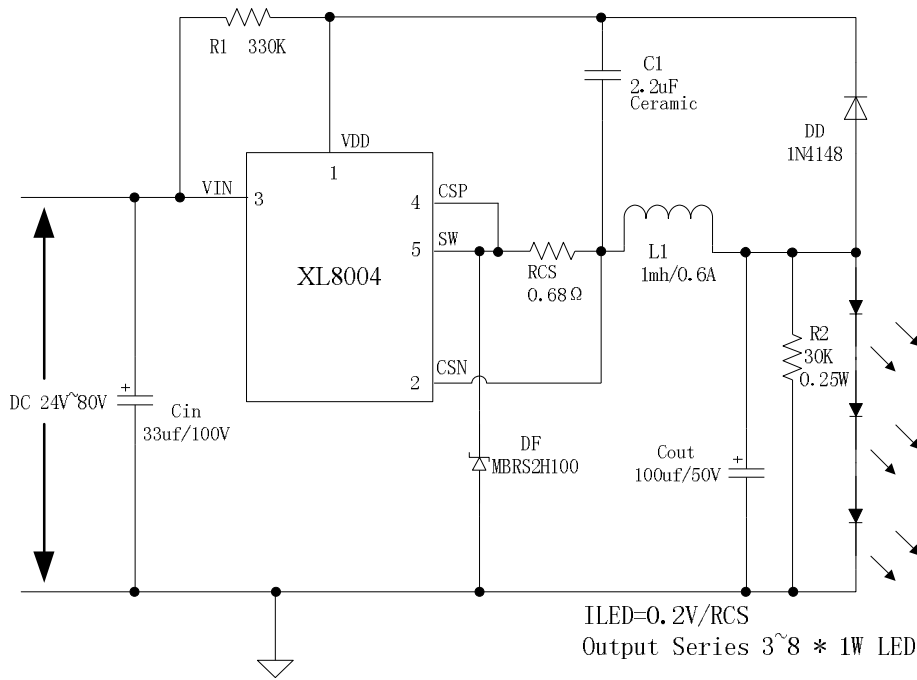

- [1] Input DC 24V~80V.
- [2] Output Constant Current Drive Series 3~8 * 1W LED.
- [3] Support Output LED Open & Short Protection.

Figure5. XL8004 System Application (3W ~ 8W)

The figure5 system parameters as following:

VIN=36V DC						
1W LED Series	Vin (V)	Iin (mA)	Vout (V)	Iout (mA)	Fosc (KHz)	Efficiency (%)
3	35.98	88	9.59	300	40.1	90.86
4	35.97	113	12.75	297	45.5	93.16
5	35.97	139	16.02	294	48.0	94.20
6	35.97	163	19.15	290	47.7	94.72
7	35.96	187	22.33	287	44.4	95.30
8	35.96	210	25.59	285	38.0	96.58
VIN=48V DC						
1W LED Series	Vin (V)	Iin (mA)	Vout (V)	Iout (mA)	Fosc (KHz)	Efficiency (%)
3	47.99	67	9.61	305	41.9	91.16
4	47.99	87	12.76	301	49.6	91.99
5	47.98	107	16.04	298	55.4	93.11
6	47.98	125	19.18	295	58.8	94.34
7	47.98	143	22.36	292	60.2	95.16
8	47.98	162	25.60	288	59.7	94.85

80V 1A Switching Current Buck PFM LED Constant Current Driver **XL8004**

VIN=60V DC						
1W LED Series	Vin(V)	Iin(mA)	Vout(V)	Iout(mA)	Fosc(KHz)	Efficiency(%)
3	59.99	56	9.61	310	42.3	88.68
4	59.98	72	12.78	307	51.2	90.85
5	59.98	88	16.06	304	58.6	92.50
6	59.98	103	19.20	300	64.1	93.23
7	59.98	118	22.39	297	68.2	93.96
8	59.97	133	25.65	294	70.6	94.55
VIN=72V DC						
1W LED Series	Vin(V)	Iin(mA)	Vout(V)	Iout(mA)	Fosc(KHz)	Efficiency(%)
3	72.06	49	9.63	315	42.1	85.91
4	72.05	63	12.80	312	51.6	87.98
5	72.05	76	16.09	309	60.0	90.80
6	72.04	89	19.23	305	66.6	91.48
7	72.04	101	22.42	302	72.0	93.06
8	72.04	115	25.68	298	76.4	92.37

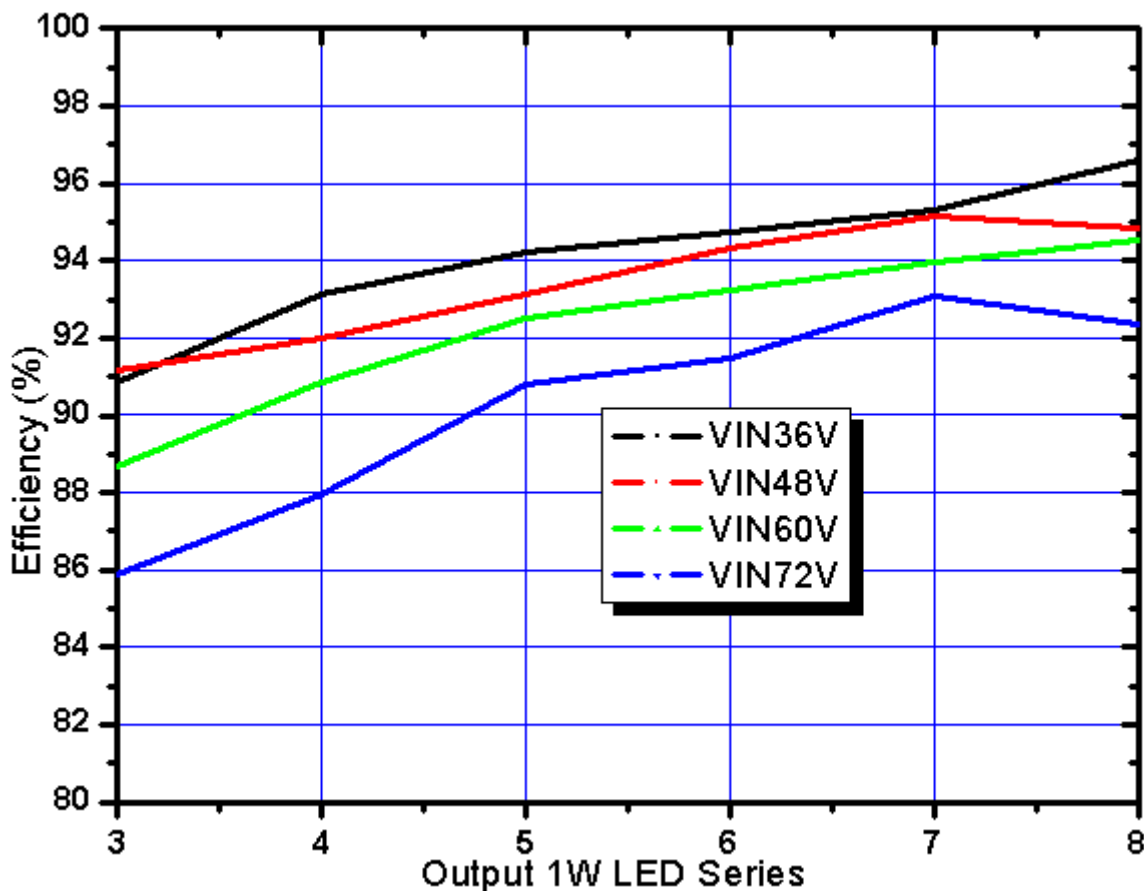
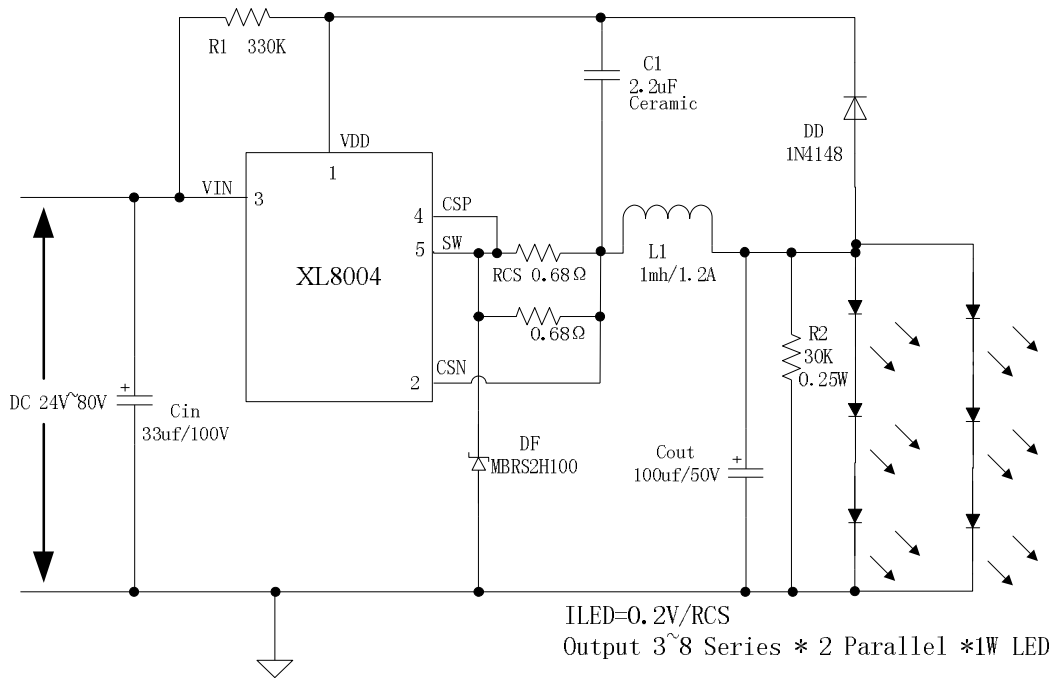

Figure6. XL8004 System efficiency curve

80V 1A Switching Current Buck PFM LED Constant Current Driver

XL8004

[2] Typical application circuit (6W ~ 16W)



- [1] Input DC 24V~80V.
- [2] Output Constant Current Drive 3~8 Series * 2 Parallel * 1W LED.
- [3] Support Output LED Open & Short Protection.

Figure7. XL8004 System Application (6W ~ 16W)

The figure7 system parameters as following:

VIN=36V DC						
1W LED Series	Vin (V)	Iin (mA)	Vout (V)	Iout (mA)	Fosc (KHz)	Efficiency (%)
3*2	35.97	183	9.77	595	22.0	88.31
4*2	35.96	234	12.99	591	24.7	91.23
5*2	35.95	286	16.28	586	25.8	92.79
6*2	35.94	336	19.48	583	25.3	94.05
7*2	35.94	385	22.70	579	23.2	94.99
8*2	35.93	433	25.88	575	19.5	95.65
VIN=48V DC						
1W LED Series	Vin (V)	Iin (mA)	Vout (V)	Iout (mA)	Fosc (KHz)	Efficiency (%)
3*2	47.98	140	9.78	601	23.4	87.50
4*2	47.97	179	13.00	597	27.6	90.38
5*2	47.96	218	16.29	593	30.6	92.39
6*2	47.96	256	19.49	589	32.3	93.50
7*2	47.95	294	22.71	585	32.9	94.24
8*2	47.95	330	25.91	581	32.4	95.14

80V 1A Switching Current Buck PFM LED Constant Current Driver **XL8004**

VIN=60V DC						
1W LED Series	Vin(V)	Iin(mA)	Vout(V)	Iout(mA)	Fosc(KHz)	Efficiency(%)
3*2	59.96	115	9.95	609	24.1	87.88
4*2	59.96	148	13.22	605	29.0	90.13
5*2	59.96	180	16.53	600	33.0	91.89
6*2	59.96	211	19.73	596	35.9	92.95
7*2	59.95	242	22.98	592	38.0	93.77
8*2	59.95	271	26.18	587	39.0	94.59
VIN=72V DC						
1W LED Series	Vin(V)	Iin(mA)	Vout(V)	Iout(mA)	Fosc(KHz)	Efficiency(%)
3*2	72.08	97	9.86	615	24.2	86.73
4*2	72.07	124	13.12	611	29.4	89.70
5*2	72.06	151	16.43	606	34.0	91.50
6*2	72.05	178	19.66	603	37.7	92.44
7*2	72.04	204	22.90	598	40.7	93.18
8*2	72.04	229	26.11	594	43.0	94.01

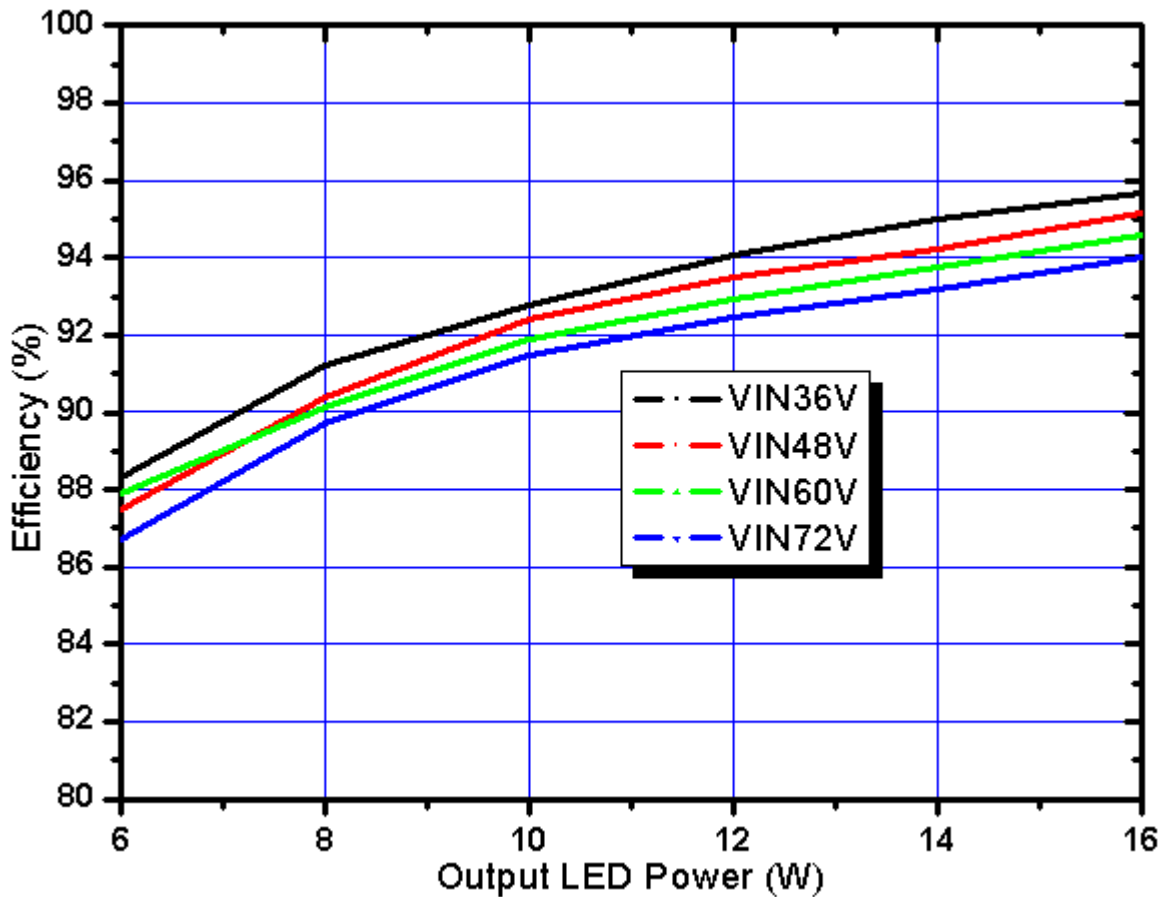
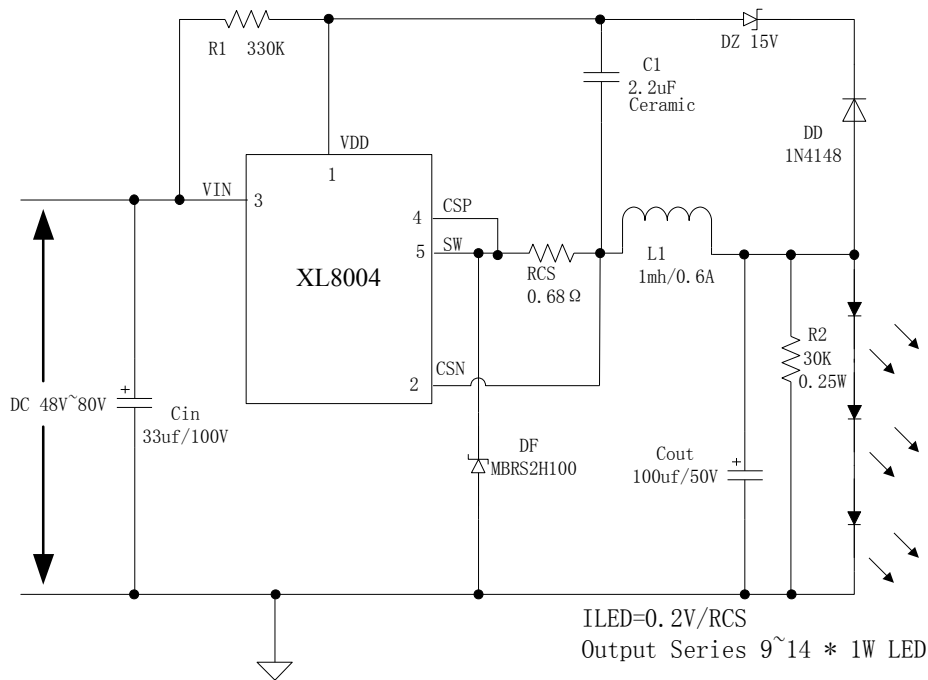

Figure8. XL8004 System efficiency curve

80V 1A Switching Current Buck PFM LED Constant Current Driver

XL8004

[3] Typical application circuit (9W ~ 14W)



- [1] Input DC 48V~80V.
- [2] Output Constant Current Drive Series 9~14 * 1W LED.
- [3] Support Output LED Open & Short Protection.

Figure9. XL8004 System Application (9W ~ 14W)

The figure9 system parameters as following:

VIN=48V DC						
1W LED Series	Vin(V)	Iin(mA)	Vout(V)	Iout(mA)	Fosc(KHz)	Efficiency(%)
9	47.99	173	28.69	276	66.8	95.4
10	47.99	191	31.93	274	61.3	95.4
11	47.98	207	35.15	272	53.5	96.3
12	47.97	225	38.41	271	43.1	96.4
13	47.98	242	41.63	270	30.4	96.8
VIN=60V DC						
1W LED Series	Vin(V)	Iin(mA)	Vout(V)	Iout(mA)	Fosc(KHz)	Efficiency(%)
9	59.99	141	28.63	278	84.4	94.1
10	59.99	155	31.88	276	83.8	94.6
11	59.99	169	35.10	274	81.0	94.9
12	59.98	183	38.34	272	76.6	95.0
13	59.98	196	41.58	270	70.5	95.5
14	59.98	209	44.80	268	62.3	95.8

80V 1A Switching Current Buck PFM LED Constant Current Driver

XL8004

VIN=72V DC						
1W LED Series	Vin(V)	Iin(mA)	Vout(V)	Iout(mA)	Fosc(KHz)	Efficiency(%)
9	72.04	120	28.61	281	94.4	93.0
10	72.03	132	31.86	278	96.5	93.2
11	72.02	143	35.07	276	97.2	94.0
12	72.02	156	38.33	274	96.4	93.5
13	72.02	168	41.56	272	94.2	93.4
14	72.01	180	44.78	269	90.5	92.9

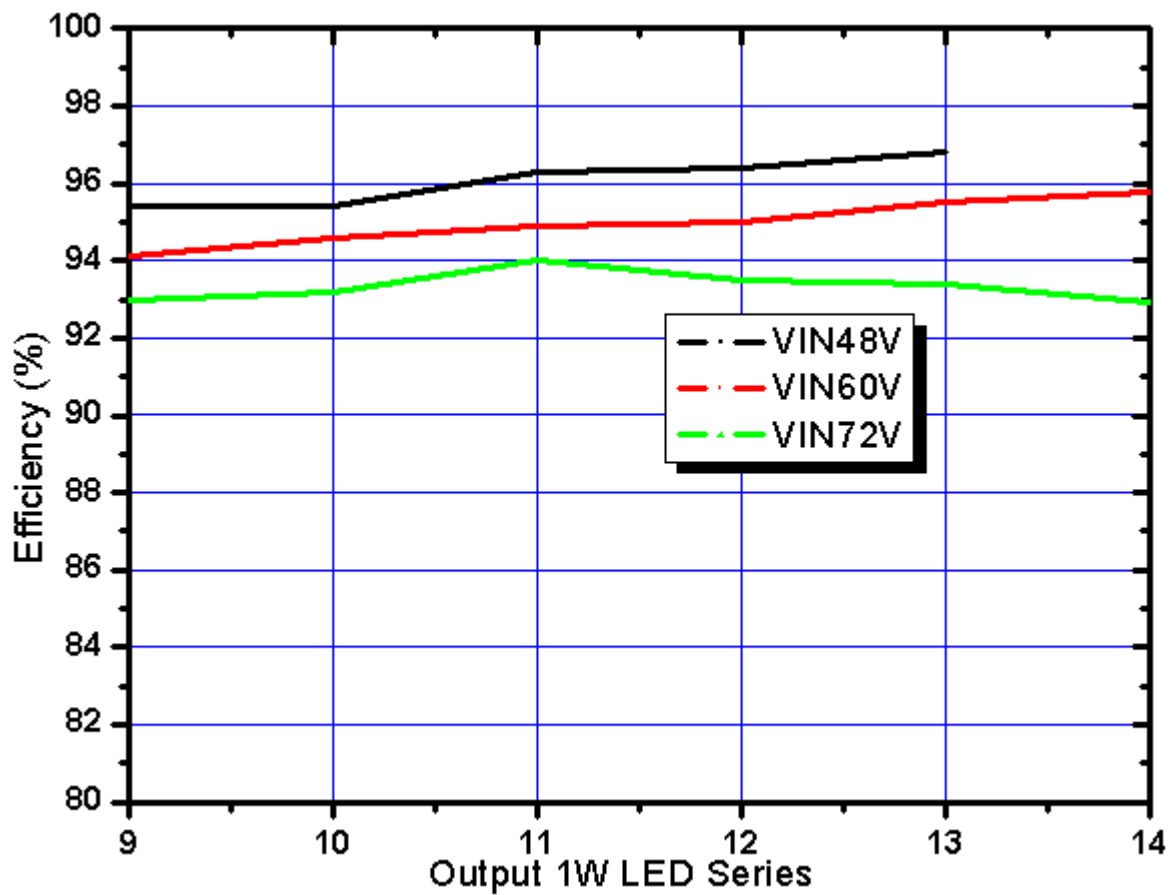

Figure10. XL8004 System efficiency curve

80V 1A Switching Current Buck PFM LED Constant Current Driver

XL8004

Package Information

TO252-5L

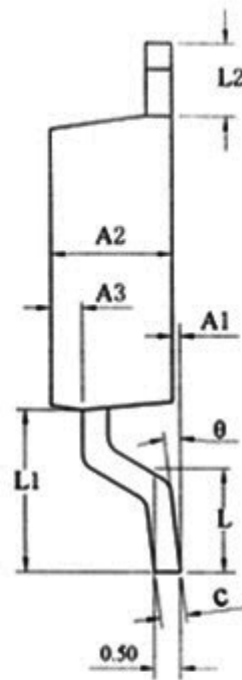
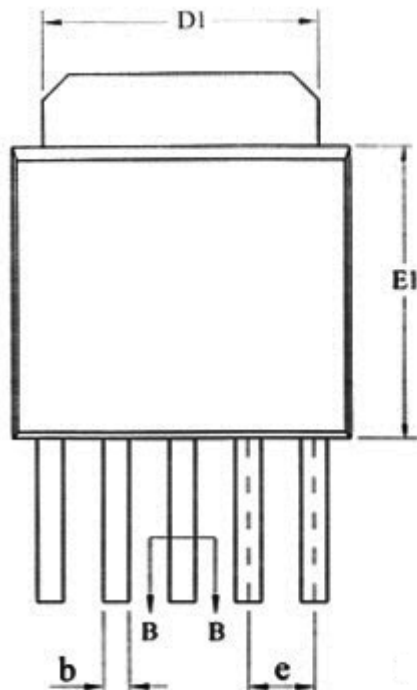

SYMBOL	MILLIMETER		
	MIN	NOM	MAX
A1	0.05	0.15	0.25
A2	2.10	2.30	2.50
A3	0.50	0.60	0.70
b	0.46	—	0.60
b1	0.45	0.50	0.55
c	0.49	—	0.56
c1	0.48	0.50	0.52
D	6.30	6.50	6.70
D1	5.30REF		
E1	5.30	5.50	5.70
e	1.27BSC		
L	1.40	1.50	1.60
L1	3.00	3.10	3.30
L2	1.40BSC		
θ	0	—	8°

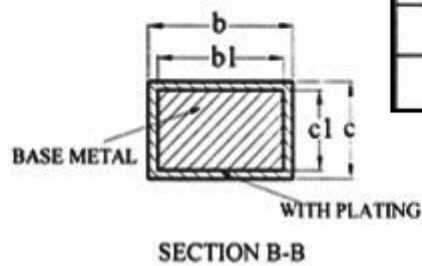
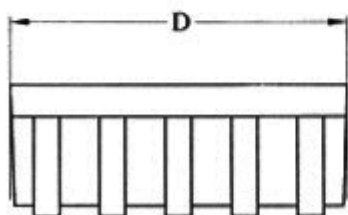

X-ON Electronics

Largest Supplier of Electrical and Electronic Components

Click to view similar products for [LED Display Drivers](#) category:

Click to view products by [XLSEMI](#) manufacturer:

Other Similar products are found below :

[MAP9000QNRH](#) [AP5726WUG-7](#) [AL8806QMP-13](#) [AP5726FDCG-7](#) [AS3693B-ZTQT](#) [AP5725WUG-7](#) [MAX139EQH+D](#) [STP16DP05PTR](#)
[STP16CPP05PTR](#) [STP16CPP05XTTR](#) [LV5236VZ-TLM-H](#) [BP9911CC](#) [ZXLD1366QEN8TC](#) [MT7725D](#) [TX6143](#) [SY6813PEC](#) [SD1002L4](#)
[AW3643CSR](#) [MP3370GN-Z](#) [LA2284L-G09-T](#) [SEDA](#) [SCT2027CSSG](#) [LYT3315D](#) [LYT3324D](#) [LYT4211E2](#) [LYT4214E2](#) [LYT4215E2](#)
[LYT4217E2](#) [LYT4218E2](#) [LYT4222E](#) [LYT4317E2](#) [LYT4321E](#) [LYT4323E](#) [LYT4324E3](#) [LYT4326E3](#) [TPS92020DR](#) [TPS92691PWPR](#)
[BCR420U](#) [HV9801ALG-G](#) [IS31FL3199-QFLS2-TR](#) [IS31FL3731-QFLS2-TR](#) [CAT4238TD](#) [SCT2001ASIG](#) [SCT2024CSTG](#) [SCT2167CSOG](#)
[SCT2167CSSG](#) [STP16CPPS05XTTR](#) [TLE4241GMFUMA1](#) [ICM7212MIQH+D](#) [ICM7212AIQH+D](#)