

Features

- Operating Voltage (V_{DD}): 3.3V~5.5V
- UART pin Voltage (V_{DDIO}): 1.8V~ V_{DD} (Less than V_{DD} voltage)
- Power down and wake-up functions to reduce power consumption
- Fully integrated 12MHz oscillator with 0.25% accuracy for all USB modes which requires no external components
- USB interface
 - USB 2.0 Full Speed compatible
 - Implements USB Human Interface Device (HID) class
 - Internal 1.5k Ω pull-high resistor on D+ pin
- Fully-duplex Universal Asynchronous Receiver and Transmitter Interface – UART
 - Supports Baud Rate up to 115200bps
 - Supports maximum 32 bytes transmit buffer and 32 bytes receive buffer
 - UART Data formats supported:
 - Data bits: 8
 - Stop bits: 1 and 2
 - Parity: odd, even, no parity
 - Supports RX pin resume signal to request a remote wake-up
 - Supports VDDIO pin for UART pins power supply
- Supports standard Windows[®] drivers for Windows XP, Vista, Win 7, Win 8/8.1, Win10
- Package types: 10-pin SOP

General Description

The HT42B564-x device is a high performance USB to UART bridge controller with fully integrated USB and UART interface functions, designed for applications that communicate with various types of UART. The device includes a USB 2.0 full speed compatible interface which is used for PC communication. The device also includes a fully integrated high speed oscillator which is used as clock source for the USB and UART baud rate generator. The baud rate generator can support up to 115200bps of baud rate for the UART interface.

USB Bridge IC Naming Rules

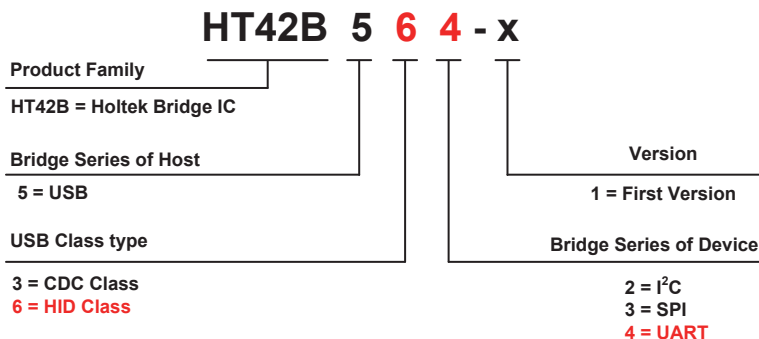

Selection Table

Most features are common to all devices. The following table summarises the main features of each device.

Part No.	Description	VDD	USB	Virtual COM	HID	FIFO/Buffer	Interface Data Rate	I/O VDD	Package
HT42B532-x	USB to I ² C Bridge	3.3V~5.5V	Full-Speed	√	—	TX: 62 bytes RX: 62 bytes	Up to 400kHz	√	8SOP 10MSOP
HT42B533-x	USB to SPI Bridge			√	—	TX: 128 bytes RX: 128 bytes	Up to 8MHz	√	10MSOP 16NSOP
HT42B534-x	USB to UART Bridge			√	—	TX: 128 bytes RX: 128 bytes	Up to 3Mbps Baud	√	8/10SOP 10MSOP 16NSOP
HT42B564-x	USB (HID) to UART Bridge			—	√	TX: 32 bytes RX: 32 bytes	Up to 115.2kbps Baud	√	10SOP

Block Diagram

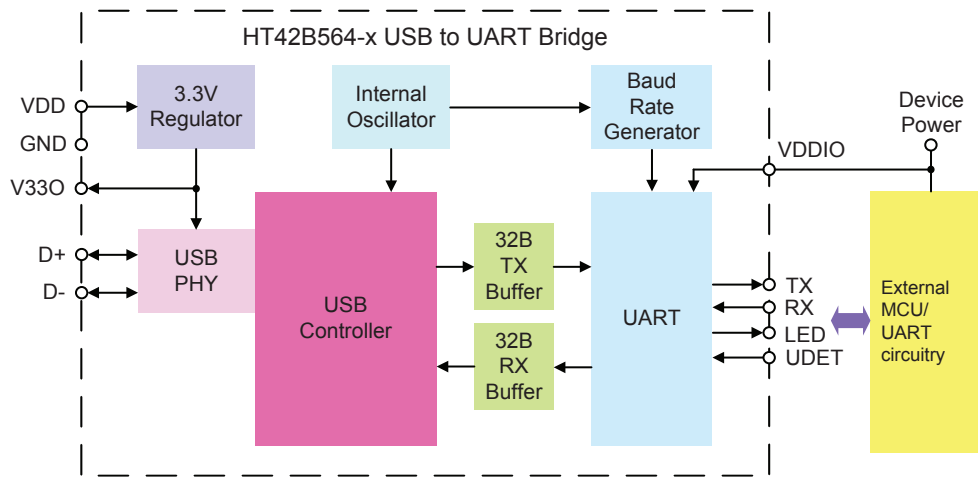

Pin Assignment

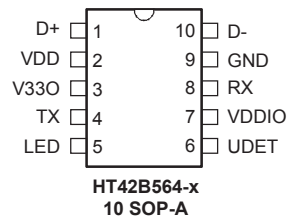

Package Type	Marking
10SOP	HT42B564-x

Note: x=1 for version number.

Pin Description

Pin Name	Type	Description
D+	I/O	USB D+ Line
D-	I/O	USB D- Line
TX	O	Asynchronous data output – UART Transmit
RX	I	Asynchronous data input – UART Receive
LED	O	TX/RX signal LED indication, active low
UDET	I	USB plug-in/out detect pin
V330	O	3.3V regulator output
VDDIO	PWR	Positive power supply for TX/RX pins
VDD	PWR	Positive power supply, USB bus power
GND	PWR	Negative power supply, ground

Absolute Maximum Ratings

Supply Voltage	$V_{SS}-0.3V$ to $V_{SS}+6.0V$	I_{OH} Total	-80mA
Input Voltage	$V_{SS}-0.3V$ to $V_{DD}+0.3V$	I_{OL} Total	80mA
Storage Temperature	-55°C to 150°C	Total Power Dissipation	500mW
Operating Temperature	-40°C to 85°C		

Note: These are stress ratings only. Stresses exceeding the range specified under "Absolute Maximum Ratings" may cause substantial damage to these devices. Functional operation of these devices at other conditions beyond those listed in the specification is not implied and prolonged exposure to extreme conditions may affect devices reliability.

D.C Characteristics

 $T_a=25^{\circ}C$

Symbol	Parameter	Test Conditions		Min.	Typ.	Max.	Unit
		V_{DD}	Conditions				
V_{DD}	Operating Voltage	—	—	3.3	—	5.5	V
V_{DDIO}	UART Pins VDDIO input voltage	—	—	1.8	—	V_{DD}	V
I_{DD}	Operating Current	5V	No load, USB Plug-in	—	11	16	mA
I_{SUS}	Suspend Current – USB	5V	Suspend mode, No load, USB on, other peripherals off	—	360	450	μA
I_{STB}	Standby Current – Non-USB	3V	Standby mode, No load, USB Plug-out, other peripherals off, VDD power from VDDIO	—	0.1	1.0	μA
V_{IL}	Input Pin Input Low Voltage	—	—	0	—	$0.2V_{DDIO}$	V
V_{IH}	Input Pin Input High Voltage	—	—	$0.8V_{DDIO}$	—	V_{DDIO}	V
I_{OL}	I/O Pin Sink Current	3V	$V_{OL} = 0.1V_{DDIO}$	4	8	—	mA
		5V		10	20	—	mA
I_{OH}	I/O Pin Source Current	3V	$V_{OH} = 0.9V_{DDIO}$	-2	-4	—	mA
		5V		-5	-10	—	mA
R_{PH}	I/O Pin Pull-high Resistance	3V	—	20	60	100	k Ω
		5V	—	10	30	50	k Ω
I_{LEAK}	Input Leakage Current	3V	$V_{IN} = V_{DD}$ or $V_{IN} = V_{SS}$	—	—	± 1	μA
		5V		—	—	± 1	μA
V_{V330}	3.3V Regulator Output Voltage	5V	$I_{V330} = 70mA$	3.0	3.3	3.6	V
R_{UDP1}	Pull-high Resistance between D+ and V330	3.3V	—	-5%	1.5	+5%	k Ω

A.C Characteristics

Ta=25°C

Symbol	Parameter	Test Condition		Min.	Typ.	Max.	Unit
		V _{DD}	Condition				
f _{HIRC}	High Speed Internal RC Oscillator	3.3V~5.5V	USB mode	-0.25%	12	+0.25%	MHz
t _{SST}	System Start-up Timer Period	—	RX pin Wake-up from power down mode	16	—	—	t _{HIRC}
t _{RSTD}	System Reset Delay Time	—	Power-on reset	25	50	100	ms

Power-on Reset Characteristics

Ta=25°C

Symbol	Parameter	Test Conditions		Min.	Typ.	Max.	Unit
		V _{DD}	Conditions				
V _{POR}	V _{DD} Start Voltage to Ensure Power-on Reset	—	—	—	—	100	mV
RR _{POR}	V _{DD} Rising Rate to Ensure Power-on Reset	—	—	0.035	—	—	V/ms
t _{POR}	Minimum Time for V _{DD} Stays at V _{POR} to Ensure Power-on Reset	—	—	1	—	—	ms

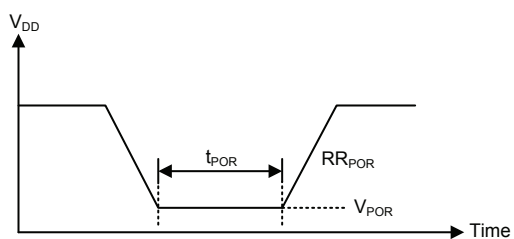

USB Interface

The USB interface, being USB 2.0 full-speed compatible, is a 4-wire serial bus that allows communication between a host device and up to 127 max peripheral devices on the same bus. A token based protocol method is used by the host device for communication control. Other advantages of the USB bus include live plugging and unplugging and dynamic device configuration. As the complexity of USB data protocol does not permit comprehensive USB operation information to be provided in this datasheet, the reader should therefore consult other external information for a detailed understanding of the USB interface.

Power Planes

There are two power planes for the device and they are the USB bus power input (VDD) and 3.3V regulator output (V330).

For the USB SIE, VDD will supply all circuits related to the USB SIE and be sourced from pin "VDD". Once the USB device is removed from the USB bus and there is no power on the USB BUS, the USB SIE circuit will no longer be operational.

USB Interface Operation

To communicate with an external USB host, the internal USB module has external pins known as D+ and D- along with the 3.3V regulator output V330. A Serial Interface Engine, SIE, decodes the incoming USB data stream and transfers it to the correct endpoint buffer memory known as the FIFO. The USB module has 3 endpoints, EP0 ~ EP2. Endpoint 0 supports the Control transfer while endpoint 1 ~ endpoint 2 support the Interrupt. The HT42B564-x Bridge IC supports the USB Human Interface Device Class, HID, for communication.

Endpoint	Transfer Type
0	Control
1	Interrupt In
2	Interrupt Out

USB Endpoint Transfer Type

If there is no signal on the USB bus for over 3ms, the USB device will enter the suspend mode. The device enters the suspend state to meet the requirements of the USB suspend current specification. When the resume signal is asserted by the USB host, the device will be woken up and leave the suspend mode.

As the USB device has a remote wake-up function, the USB device can be woken-up the USB host by sending a remote wake-up pulse. Once the USB host receives a remote wake-up signal from the USB device, the host will send a resume signal to the device.

USB VID and PID Configuration

The device has configured the default Vendor ID (VID: 0x04D9), Product ID (PID: 0xB564) and product description strings of "USB HID UART Bridge".

This device has been configured to the default USB configuration data as shown in the following table.

Parameter	Value (hex)
USB Vendor ID (VID)	0x04D9
USB Product ID (PID)	0xB564
Remote wake-up	Default enable
Manufacturer Name	Holtek
Product Description	USB HID UART Bridge
Serial Number	0000

USB Data Format

Read Data: 32 bytes FIFO for each read data, the first byte valid for this number of data length received, ranges from 0 to 31. If there are more than 31 bytes of data, it will be divided into multiple times read.

Write Data: 32 bytes FIFO for each write data to be written first byte number, ranging from 0 to 31. If there are more than 31 bytes then write multiple times.

UART Interface

The HT42B564-x contains an integrated full-duplex asynchronous serial communications UART interface that enables communication with external devices that contain a serial interface. The UART function has many features and can transmit and receive data serially by transferring a frame of data with eight data bits per transmission as well as being able to detect errors when the data is overwritten or incorrectly framed. The UART function possesses its own internal interrupt which can be used to indicate when a reception occurs or when a transmission terminates.

The integrated UART function contains the following features:

- Full-duplex, asynchronous communication
- 8 bits character length
- Even, odd or no parity options
- One or two stop bits
- Baud rate generator with prescaler
- 32-byte Deep FIFO Transmit Data Buffer
- 32-byte Deep FIFO Receive Data Buffer
- RX pin wake-up function
- UART pins power supply by VDDIO pin

UART External Pins

To communicate with an external serial interface, the internal UART has two external pins known as TX and RX. The TX and RX pins are the UART transmitter and receiver pins respectively.

UART Data Transfer Scheme

The data will be transferred to the Transmit Shift Register from where it will be shifted out, LSB first, onto the TX pin at a rate controlled by the Baud Rate Generator. Data to be received by the UART is accepted on the external RX pin, from where it is shifted in, LSB first, to the Receiver Shift Register at a rate controlled by the Baud Rate Generator. The UART interface provides a 32 byte deep FIFO transmit data buffer and a 32 byte deep FIFO receive data buffer for applications.

For data transfer, the UART function utilises a non-return-to-zero, more commonly known as NRZ, format. This is composed of one start bit, eight data bits and one or two stop bits. Parity is supported by the UART hardware and can be setup to be even, odd or no parity. For the most common data format, 8 data bits along with no parity and one stop bit, denoted as 8, N, 1, is used as the default setting, which is the setting at power-on.

The following diagram shows the transmit and receive waveforms for 8-bit data format.

Baud Rate Generator

To setup the speed of the serial data communication, the UART function contains its own dedicated baud rate generator. The default UART baud rate is 9600bps and it can be controlled by the application program.

The baud rate and miss rate table:

Baud Rate	Real Rate	Miss Rate (%)
9600	9603.841537	0.04
19200	19207.68307	0.04
38400	38461.53846	0.16
57600	57692.30769	0.16
115200	115384.6154	0.16

UART Power Down and Wake-up

If the USB host sends a suspend signal to the HT42B564-x USB device, it will enter the suspend mode. It is recommended to ensure that the UART data transmission or reception has finished before the device enters the suspend mode.

The UART function contains a receiver RX pin wake-up function. A falling edge on the RX pin will wake up the device from the suspend mode.

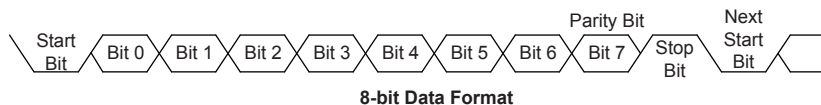

USB HID Protocol

USB VID/PID

VID: 0x04D9

PID: 0xB564

USB TO UART Command

The application program uses USB HID set/get feature command to implement UART settings. There are following command:

- Get UARTSetting Command
- Set UARTSetting Command (CMDCode=01)

Get UARTSetting Command

Request Name	Report Type	Raw Data
Get_Report	Feature	D0~D7

D1~D8: UARTSettings (Refer to Table)

Byte	Field	Size	Description
D0	CMDCode	1	Command code.
D1~D4	DTERate	4	Data terminal rate,in bits per second. (support 9600/19200/38400/57600/115200) 9600 → 80 25 00 00 19200 → 00 4B 00 00 38400 → 00 84 03 00 57600 → 00 E1 00 00 115200 → 00 C2 01 00
D5	CharFromat	1	Stop bits 0-1 Stop bits 1-2 Stop bits
D6	ParityType	1	Parity 0-None 1-Odd 2-Even
D7	DataBits	1	Data bits(only 8)

UARTSettings

Set UARTSetting Command

Request Name	Report Type	Raw Data
Set_Report	Feature	D0~D7

D0~D7: UARTSettings (Refer to Table.1)

CMDCode=01H

Write Data

Request Name	Report Type	Raw Data
Interrupt	Output	D0~D31

Endpoint size 32bytes

The first data of D0 is the data length.

Read Data

Request Name	Report Type	Raw Data
Interrupt	Input	D0~D31

Endpoint size 32bytes

The first data of D0 is the data length.

DLL Function

HT42B564-x USB Bridge DLL Function

Holtek provides a Dynamic-Link Library (DLL) to setup the HT42B564-x Bridge IC for USB to UART data communication.

The Dynamic-link library DLL is a shared library of function executable files, available in different languages for application calls to use. The complex computing and communications USB is collated into a "HIDAPI.DLL". Users can use this DLL to develop different client applications without having to spend excessive amounts of time to study and write USB related functions.

DLL Function Definition:

```

BOOL SetFeature(HANDLE hDevice, LPVOID
pData, DWORD nLen);
BOOL GetFeature(HANDLE hDevice, LPVOID
pData, DWORD nLen);
HANDLE OpenFirstHIDDevice(DWORD dwVID,
DWORD dwPID, DWORD dwUsagePage, DWORD
dwUsage, BOOL bSync);
HANDLE OpenNextHIDDevice(DWORD dwVID,
DWORD dwPID, DWORD dwUsagePage, DWORD
dwUsage, BOOL bSync);
void CloseHIDDevice(HANDLE hDevice);

```

Usage – Taking C language as an example:

- HINSTANCE hLib=LoadLibrary ("HIDAPI.DLL");
- The GetProcAddress function fetches the addresses for accessing various functions
Taking C language as an example, the declarations are as follows:

```

BOOL (*SetFeature)(HANDLE hDevice, LPVOID
pData, DWORD nLen);
BOOL (*GetFeature)(HANDLE hDevice, LPVOID
pData, DWORD nLen);
HANDLE (*OpenFirstHIDDevice)(DWORD
wVID, DWORD wPID, DWORD wUsagePage,
DWORD wUsage, BOOL bSync);
HANDLE (*OpenNextHIDDevice)(DWORD
wVID, DWORD wPID, DWORD wUsagePage,
DWORD wUsage, BOOL bSync);
void (*CloseHIDDevice)(HANDLE hDevice);

```

Get the addresses

```

(FARPROC&) OpenFirstHIDDevice=GetProcAddress
(m_hLib,"OpenFirstHIDDevice");
(FARPROC&) OpenNextHIDDevice=GetProcAddress
(m_hLib,"OpenNextHIDDevice");
(FARPROC&) CloseHIDDevice=GetProcAddress
(m_hLib,"CloseHIDDevice");
(FARPROC&) SetFeature=GetProcAddress
(m_hLib,"SetFeature");
(FARPROC&) GetFeature=GetProcAddress
(m_hLib,"GetFeature");

```

Function Description:

HANDLE OpenFirstHIDDevice(DWORD wVID, DWORD wPID, DWORD wUsagePage, DWORD wUsage, BOOL bSync);

HANDLE OpenNextHIDDevice(DWORD wVID, DWORD wPID, DWORD wUsagePage, DWORD wUsage, BOOL bSync);

Parameters:

wVID Device Vendor ID. Any VID input will be regarded as the Holtek Vendor ID 0x04D9 by default in this version. Consult with Holtek if another VID is required.

wPID Device Product ID.

wUsagePage/wUsage

The UsagePage/Usage adopted by the Report Descriptor will be written with a value of "0" if it is not specified. More detailed information is contained in the HID spec. When the same VID/PID has multiple interfaces simultaneously, it is required to specify the exact UsagePage/Usage, otherwise only the first interface handle value will be returned.

bSync Use synchronous or asynchronous transmission. Synchronous transmission means that the function will not return a value until the Input/Output has finished.

Return Value:

Represents the value of the activated device. A NULL will be returned if the open operation has failed.

When the same VID/PID USB devices exist simultaneously, the OpenFirstHIDDevice function can be used to open the first one followed by an OpenNextHIDDevice function to open the next one until a NULL is returned.

After activation, the device is able to execute ReadFile/ WriteFile operations, which are the Windows API Standard Functions.

Void CloseHIDDevice(HANDLE hDevice);

Parameters:

hDevice Represents the value of the device to be closed.

BOOL SetFeature(HANDLE hDevice, LPVOID pData, DWORD nLen)

Parameters:

hDevice Represents the value of the activated device
pData Data buffer where the Feature data is to be written. The first byte should be Report ID. A "0" value will be written to this byte if there is no Report ID.
nLen Length of the Feature data to be written. The required length should be the Firmware-defined Feature Report length with the addition of one Report ID byte.

Return value:

- 1: Write success
- 0: Write fail

BOOL GetFeature(HANDLE hDevice, LPVOID pData, DWORD nLen);

Return value:

hDevice Represents the value of the activated device
pData Data buffer where the Feature data is to be read. The first byte should be Report ID. A "0" value will be written to this byte if there is no Report ID.
nLen Length of the Feature data to be read. The required length should be the Firmware-defined Feature Report length with the addition of one Report ID byte.

Return value:

- 1: Read success
- 0: Read fail

Considerations:

- The OpenFirstHIDDevice/OpenNextHIDDevice functions start up devices with a readable and writeable permission, therefore the device specified by the VID/PID should also be readable and writable. This means that the Firmware must provide OutputReport/InputReport or Interrupt IN/Interrupt OUT.
- Use general file access functions, such as WriteFile(hDevice, ...) in the C language to write data to OutputReport or Interrupt OUT. The required data length should be the Firmware-defined OutputReport length with the addition of one Report ID byte. The first byte must be the Report ID. It will be "0" if there is no Report ID.
- Use general file access functions, such as ReadFile(hDevice, ...) in the C language, to read data from InputReport or Interrupt IN. The required data length should be the Firmware-defined InputReport length with the addition of one Report ID byte. The first byte must be the Report ID. It will be "0" if there is no Report ID.
- To use the SetFeature/GetFeature functions, the device must provide Feature Report, which means the Report Descriptor of the Firmware should contain the Feature Type.

Application Circuits

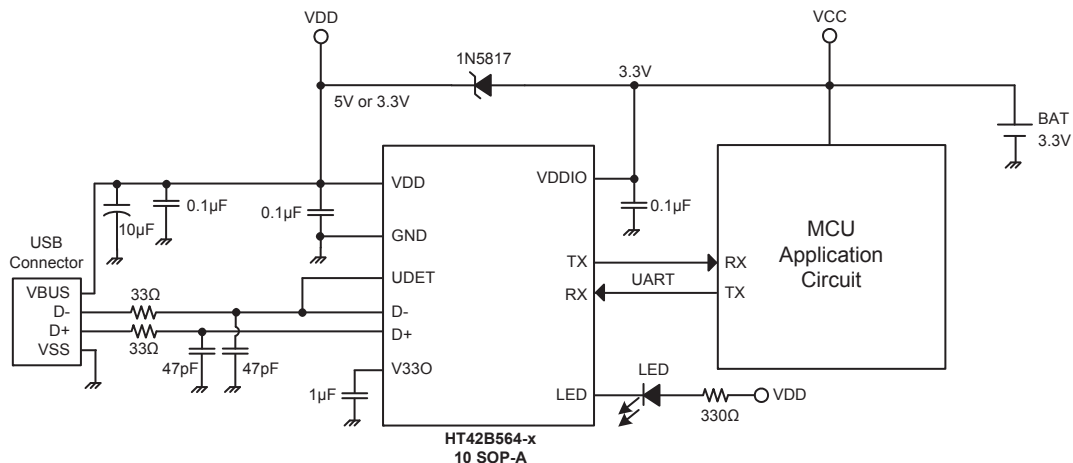

- Note: 1. The V_{CC} voltage must be less than the V_{DD} voltage. The V_{CC} supply can be sourced from a Li-battery.
2. The UDET pin can be used to detect a USB plug-in for data transfer or to detect a USB plug-out for entering the energy saving mode.

Package Information

Note that the package information provided here is for consultation purposes only. As this information may be updated at regular intervals users are reminded to consult the [Holtek website](#) for the latest version of the [Package/ Carton Information](#).

Additional supplementary information with regard to packaging is listed below. Click on the relevant section to be transferred to the relevant website page.

- Further Package Information (include Outline Dimensions, Product Tape and Reel Specifications)
- Packing Materials Information
- Carton information

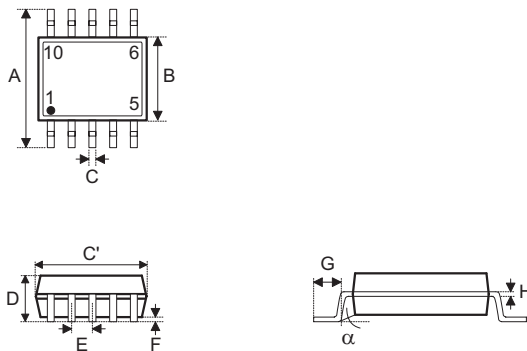
10-pin SOP (150mil) Outline Dimensions

Symbol	Dimensions in inch		
	Min.	Nom.	Max.
A	—	0.236 BSC	—
B	—	0.154 BSC	—
C	0.012	—	0.018
C'	—	0.193 BSC	—
D	—	—	0.069
E	—	0.039 BSC	—
F	0.004	—	0.010
G	0.016	—	0.050
H	0.004	—	0.010
α	0°	—	8°

Symbol	Dimensions in mm		
	Min.	Nom.	Max.
A	—	6.00 BSC	—
B	—	3.90 BSC	—
C	0.30	—	0.45
C'	—	4.90 BSC	—
D	—	—	1.75
E	—	1.00 BSC	—
F	0.10	—	0.25
G	0.40	—	1.27
H	0.10	—	0.25
α	0°	—	8°

Copyright© 2016 by HOLTEK SEMICONDUCTOR INC.

The information appearing in this Data Sheet is believed to be accurate at the time of publication. However, Holtek assumes no responsibility arising from the use of the specifications described. The applications mentioned herein are used solely for the purpose of illustration and Holtek makes no warranty or representation that such applications will be suitable without further modification, nor recommends the use of its products for application that may present a risk to human life due to malfunction or otherwise. Holtek's products are not authorized for use as critical components in life support devices or systems. Holtek reserves the right to alter its products without prior notification. For the most up-to-date information, please visit our web site at <http://www.holtek.com.tw/en/home>.

X-ON Electronics

Largest Supplier of Electrical and Electronic Components

Click to view similar products for [USB Interface IC](#) category:

Click to view products by [Holtek](#) manufacturer:

Other Similar products are found below :

[TUSB1146RNQT](#) [TUSB1146IRNQT](#) [CY7C65210-24LTXI](#) [CY7C69356-48LTXC](#) [CYUSB2304-68LTXI](#) [CY7C65642-48AXCT](#) [CYPD2119-24LQXI](#) [CYUSB3328-88LTXI](#) [USB2227-NU-11](#) [USB2251-NU-06](#) [USB3319C-GJ-TR](#) [USB3370B-EZK-TR](#) [USB5537B-4100AKZE](#) [USB3347-CP](#) [USB2230-NU-02](#) [USB2229-NU-02](#) [CG7648AM](#) [W83627HG-AW](#) [CY7C64225-28PVXCT](#) [CY7C65215A-32LTXI](#) [CYPD2120-24LQXI](#) [CYWB0164BB-BZXI](#) [CY7C65211A-24LTXI](#) [USB5807T-I/KD](#) [USB5742-I/2G](#) [USB3331E-GL-TR](#) [USB3321C-GL-TR](#) [USB1T1103MPX](#) [USB5742/2G](#) [CYPD2122-20FNXIT](#) [CYPD2122-24LQXIT](#) [LIF-UC120-SWG36ITR50](#) [MAX3456EETE+T](#) [LIF-UC120-CM36ITR50](#) [UPD360-C/6HX](#) [USB2228-NU-11](#) [UPD360-B/6HX](#) [PI3EQX7841ZDEX](#) [CYPD4225-40LQXI](#) [LAN7800-I/VSX](#) [UPD360T-B/6HX](#) [UPD360-A/6HX](#) [LAN7800/VSX](#) [MAX20037ATIB/V+](#) [MP5030CGQH-P](#) [USB7056/KDX](#) [STUSBCD01BJR](#) [CY7C65642-28LTXCT](#) [CG8454AM](#) [CYPD2119-24LQXIT](#)