



**Genesys Logic, Inc.**

---

**GL3233**

**USB 3.0 Single-LUN  
Memory Card Reader Controller**

**Datasheet**

**Revision 1.09  
Jul. 21, 2017**



## Copyright

Copyright © 2017 Genesys Logic, Inc. All rights reserved. No part of the materials shall be reproduced in any form or by any means without prior written consent of Genesys Logic, Inc.

## Ownership and Title

Genesys Logic, Inc. owns and retains of its right, title and interest in and to all materials provided herein. Genesys Logic, Inc. reserves all rights, including, but not limited to, all patent rights, trademarks, copyrights and any other propriety rights. No license is granted hereunder.

## Disclaimer

All Materials are provided “as is”. Genesys Logic, Inc. makes no warranties, express, implied or otherwise, regarding their accuracy, merchantability, fitness for any particular purpose, and non-infringement of intellectual property. In no event shall Genesys Logic, Inc. be liable for any damages, including, without limitation, any direct, indirect, consequential, or incidental damages. The materials may contain errors or omissions. Genesys Logic, Inc. may make changes to the materials or to the products described herein at anytime without notice.

## Genesys Logic, Inc.

12F., No. 205, Sec. 3, Beixin Rd., Xindian Dist. 231,

New Taipei City, Taiwan

Tel : (886-2) 8913-1888

Fax : (886-2) 6629-6168

<http://www.genesyslogic.com>

## Revision History

Revision	Date	Description
1.00	05/10/2012	First Formal Release
1.01	07/30/2012	<ol style="list-style-type: none"> <li>1. Adding WHQL/WHCK Submission ID, p7</li> <li>2. Adding LQFP 48 Pinout Diagram/Description, p7, 10, 15, 16</li> <li>3. Adding LQFP 48 Package dimension, p25</li> <li>4. Adding part number-GL3233-MNYXX in Chapter 8 ordering information, p26</li> <li>5. Update SPI Flash support list in Chapter 6, p22</li> <li>6. Adding top marking information in Chapter 7, p23, 24</li> </ol>
1.02	11/07/2012	<ol style="list-style-type: none"> <li>1. Update SPI Flash support list in Chapter 6, p22</li> </ol>
1.03	03/18/2013	<ol style="list-style-type: none"> <li>1. Modify GENERAL DESCRIPTION in Chapter 1, p6</li> <li>2. Remove OCCS in Chapter 2, p7</li> <li>3. Adding WHCK windows 8 ARM Submission ID, p7</li> <li>4. Modify description of X1, X2 in p11, 13, 15</li> <li>5. Update SPI Flash support list in Chapter 6, p22</li> </ol>
1.04	04/03/2013	<ol style="list-style-type: none"> <li>1. Adding MMC v4.5 compliant in Chapter 2, p7</li> </ol>
1.05	06/18/2014	<ol style="list-style-type: none"> <li>1. Modify eMMC spec in Ch2, p7.</li> <li>2. Update SPI NOR FLASH SUPPORT LIST in Ch6, p23</li> </ol>
1.06	08/05/2015	Update Table 5.4 Reset Timing, p.22
1.07	11/19/2015	Update Table 5.3 DC Characteristics, p. 20
1.08	05/03/2016	Update CH2 Features
1.09	07/21/2017	Update CH6 SPI NOR Flash Support List

## Table of Contents

<b>CHAPTER 1 GENERAL DESCRIPTION.....</b>	<b>6</b>
<b>CHAPTER 2 FEATURES.....</b>	<b>7</b>
<b>CHAPTER 3 PIN ASSIGNMENT.....</b>	<b>9</b>
<b>3.1 LQFP 64 Pinout.....</b>	<b>9</b>
<b>3.2 LQFN 46 Pinout.....</b>	<b>10</b>
<b>3.3 LQFP 48 Pinout.....</b>	<b>11</b>
<b>3.4 Pin Description.....</b>	<b>12</b>
<b>CHAPTER 4 BLOCK DIAGRAM.....</b>	<b>19</b>
<b>4.1 Super Speed and HS/FS PHY.....</b>	<b>19</b>
<b>4.2 USB Controller.....</b>	<b>19</b>
<b>4.3 EPFIFO.....</b>	<b>19</b>
<b>4.4 MCU.....</b>	<b>19</b>
<b>4.5 MHE (Media Hardware Engine).....</b>	<b>20</b>
<b>4.6 Regulator.....</b>	<b>20</b>
<b>CHAPTER 5 ELECTRICAL CHARACTERISTICS.....</b>	<b>21</b>
<b>5.1 Temperature Conditions.....</b>	<b>21</b>
<b>5.2 Operating Conditions.....</b>	<b>21</b>
<b>5.3 DC Characteristics.....</b>	<b>21</b>
<b>5.4 AC Characteristics of Reset Timing.....</b>	<b>22</b>
<b>CHAPTER 6 SPI NOR FLASH SUPPORT LIST.....</b>	<b>24</b>
<b>CHAPTER 7 PACKAGE DIMENSION.....</b>	<b>25</b>
<b>CHAPTER 8 ORDERING INFORMATION.....</b>	<b>28</b>

## List of Figures

Figure 3.1 - LQFP 64 Pinout Diagram .....	9
Figure 3.2 - LQFN 46 Pinout Diagram.....	10
Figure 3.3 - LQFP 48 Pinout Diagram .....	11
Figure 4.1 - Functional Block Diagram.....	19
Figure 5.1 - Timing Diagram of Reset Width .....	22
Figure 5.2 - Timing Diagram of Power Good to USB Command Receive Ready .....	22
Figure 7.1 - LQFP 64 Pin Package.....	25
Figure 7.2 - LQFN 46 Pin Package .....	26
Figure 7.3 - LQFP 48 Pin Package.....	27

## List of Tables

Table 3.1 - LQFP64 Pin Description.....	12
Table 3.2 - LQFN46 Pin Description .....	15
Table 3.3 - LQFP48 Pin Description.....	17
Table 5.1 - Temperature Conditions .....	21
Table 5.2 - Operating Conditions.....	21
Table 5.3 - DC Characteristics .....	21
Table 5.4 - Reset Timing .....	23
Table 5.5 - SD/MMC Card Clock Frequency .....	23
Table 5.6 - MS Card Clock Frequency .....	23
Table 6.1 - SPI NOR Flash Support List.....	24
Table 8.1 - Ordering Information .....	28



## CHAPTER 1 GENERAL DESCRIPTION

GL3233 is a USB 3.0 Single-LUN card reader controller which can support various types of memory cards, such as CompactFlash™, Secure Digital™ (SD), SDHC, miniSD, microSD (T-Flash), MultiMediaCard™ (MMC), RS-MMC, MMCmicro, MMCmobile, Memory Stick™ (MS), Memory Stick Duo™ (MS Duo), High Speed Memory Stick™ (HS MS), Memory Stick PRO™ (MS PRO), Memory Stick PRO™ Duo (MS PRO Duo), Memory Stick PRO-HG™ (MS PRO-HG), MS PRO Micro and xD-Picture Card™ on one chip. It also supports SDXC and Memory Stick XC high density memory cards (capacity up to 2TB) and high speed SD3.0 UHS-I memory cards.

The GL3233 integrates a high speed 8051 microprocessor and a high efficiency hardware engine for the best data transfer performance between USB and various memory card interfaces. It supports ISP (In System Programming) for firmware upgrade into the external SPI Flash via USB port. It also integrates 5V to 3.3V and 3.3V to 1.2V regulators and power MOSFETs which can reduce the system BOM cost.

## CHAPTER 2 FEATURES

- USB specification compliance
  - Comply with Universal Serial Bus 3.0 Specification rev. 1.0 (USB 3.0)
  - Comply with Universal Serial Bus Specification rev. 2.0 (USB 2.0)
  - Comply with USB Mass Storage Class Specification rev. 1.0
  - Support USB Mass Storage Class Bulk-Only Transport (BOT)
  - Support 1 device address and up to 3 endpoints: Control (0) / Bulk Data Write Out (1) / Bulk Data Read In (2)
  - Support 5 Gbps/SuperSpeed, 480 Mbps/high-speed, and 12 Mbps/full-speed transfer rates
- Integrated USB building blocks
  - SuperSpeed/USB2.0 transceiver macro (UTM), Serial Interface Engine (SIE) and embedded Power-On Reset (POR)
- Embedded high speed 8051 micro-controller
- High efficiency hardware DMA engine improves data transfer performance between USB and flash card interfaces
- Support CompactFlash™ v6.0 with PIO mode 6 / Ultra DMA mode 7 and LBA48 (Capacity up to 144PB)
- Support Secure Digital™ v1.0 / v1.1 / v2.0/ SDHC / SDXC (capacity up to 2TB)
- Support Secure Digital™ v3.0 UHS-I (Ultra High Speed): SDR12/SDR25/SDR50/DDR50/SDR104
- Support Secure Digital™ v5.0
- Support MultiMediaCard™ (MMC)
  - MMC specification v3.x/ v4.0/ v4.1/ v4.2
  - x1/ x4/ x8 bit data bus
- Support Embedded MultiMediaCard™ (eMMC)
  - eMMC specification v4.3/ v4.4/ v4.5/ v5.0
  - High Speed SDR/ High Speed DDR
- Support Memory Stick™ / Memory Stick PRO / Memory Stick PRO Duo / Memory Stick Micro /Memory Stick PRO-HG / Memory Stick XC (capacity up to 2TB)
  - Compliant with Memory Stick Series Specification: MS v1.43, MS PRO v1.05, MS Micro v1.04 (MS HG Micro v1.00), MS PRO-HG Duo 1.03, MS XC Duo v1.00, MS XC-HG Duo v1.00, MS XC Micro v1.00 and MS XC-HG Micro v1.00
  - Support Read/Write quad data access (512ByteX4) for MS PRO-HG to enhance the transmission rate
- Support xD-Picture Card™ v1.2C Type M/H
- Support ISP (In System Programming) for firmware upgrade into the external SPI Flash via USB port
- On-Chip power MOSFETs for supplying flash media card power
- On-chip 5V to 3.3V and 3.3V to 1.2V regulator
- Support U0/U1/U2/U3 power management mode
- Pass the USB-IF Test Procedure for SuperSpeed product (TID: 340810011)
- Pass WHCK (Windows Hardware Certification Kit) test for Windows 8 (Submission ID: 1508144)
- Pass WHCK (Windows Hardware Certification Kit) test for Windows 8 ARM (Submission ID: 1551618)
- Pass WHQL (Windows Hardware Quality Lab) test for Windows 7 (Submission ID: 1497856)
- Available in LQFP64 pin package (7x7mm) which can support one LUN: SD/MS/xD/CF
- Available in LQFN46 pin package (6.5x4.5mm) which can support one LUN: SD/MS/xD



- Available in LQFP48 pin package (7x7mm) which can support one LUN: SD/MS/xD



## CHAPTER 3 PIN ASSIGNMENT

### 3.1 LQFP 64 Pinout



Figure 3.1 - LQFP 64 Pinout Diagram

### 3.2 LQFN 46 Pinout

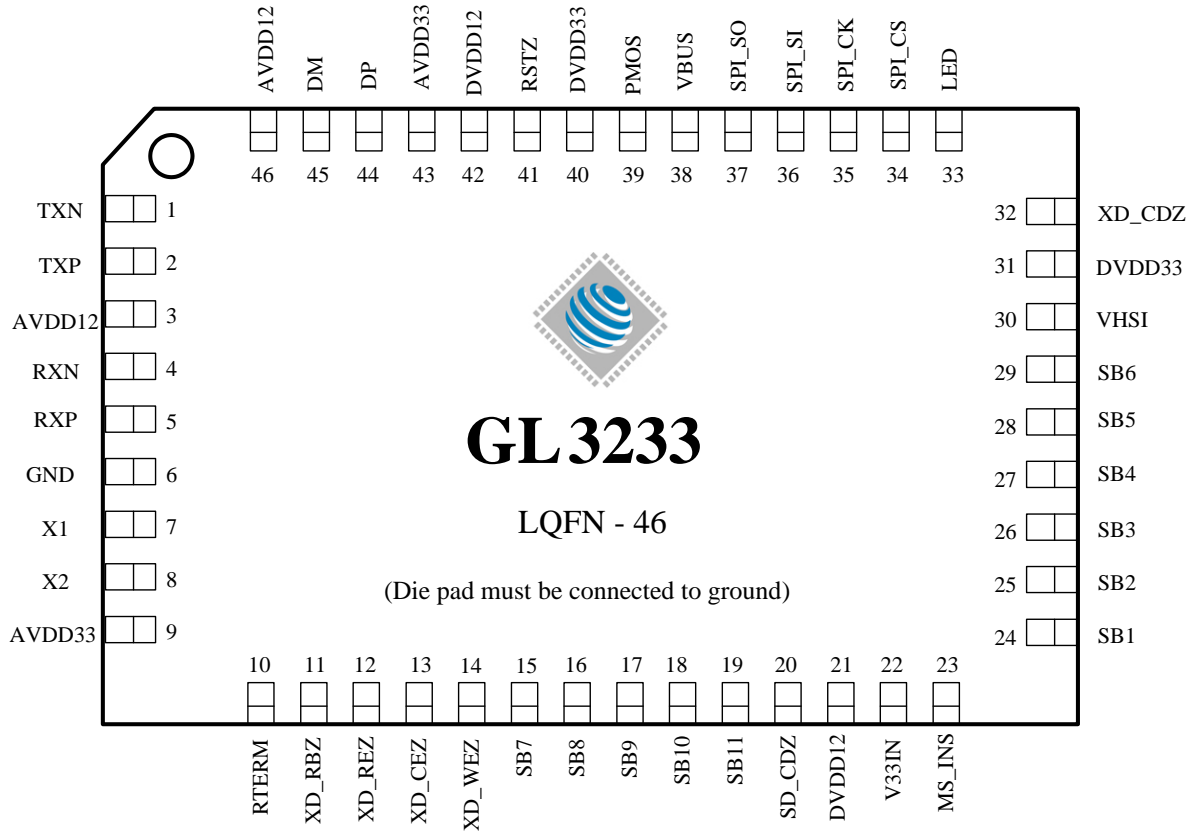

Figure 3.2 - LQFN 46 Pinout Diagram

### 3.3 LQFP 48 Pinout

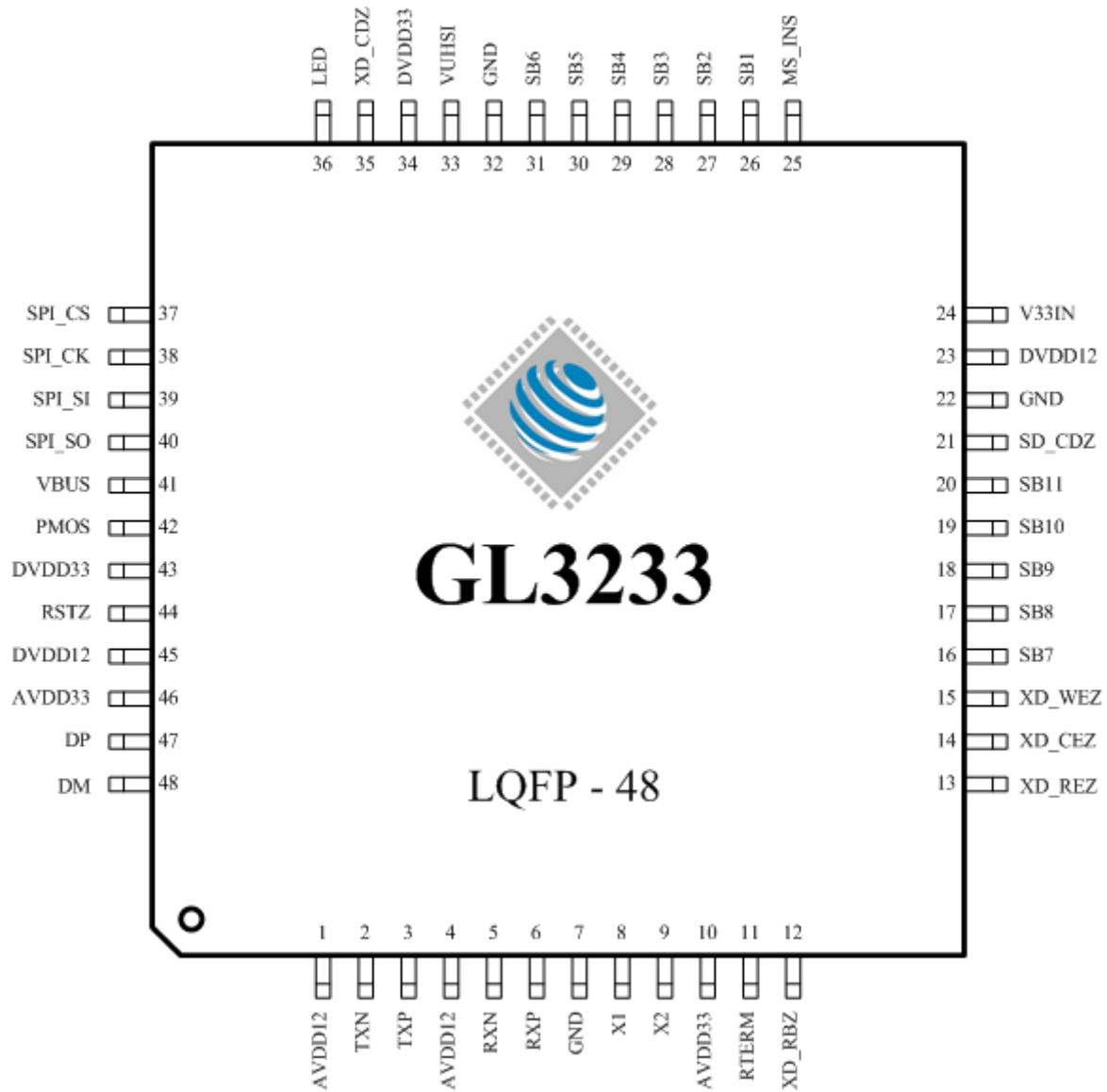

Figure 3.3 - LQFP 48 Pinout Diagram

### 3.4 Pin Description

**Table 3.1 - LQFP64 Pin Description**

Pin Name	LQFP 64 Pin	Type	Description
<b>Power/Ground</b>			
AVDD12	3,7	P	Analog 1.2V power source
AVDD33	13,64	P	Analog 3.3V power source
DVDD12	29,63	P	Digital 1.2V power source
DVDD33	40,50	P	Digital 3.3V power source
V33IN	30	P	3.3V to 1.2V regulator power source. Input range from 1.8V to 3.3V
VUHSI	39	P	SD 3.0 IO PAD Power, the power source of this pin comes from the internal regulator of GL3233 and no need of external power input
VBUS	48	P	5V Power source
PMOS	49	P	Card power 900mA
GND	4,10,38,51	P	Ground
<b>USB PHY Interface</b>			
DP	1	A	USB 2.0 D+
DM	2	A	USB 2.0 D-
TXN	5	A	USB 3.0 TX-
TXP	6	A	USB 3.0 TX+
RXN	8	A	USB 3.0 RX-
RXP	9	A	USB 3.0 RX+
RTERM	14	A	USB reference resistor. This pin is used to control the level of USB signal. A 680ohm, 1% resistor is recommended to be populated between RTERM and GND
X1	11	I	25MHz XTAL input. It can be connected to external 25MHz clock input
X2	12	B	25MHz XTAL output
<b>Memory Card Interface</b>			
SD_CDZ	28	I, pu	SD card detect 0: Card insert 1: No card
MS_INS	31	I, pu	MS insertion detect 0: Card insert 1: No card
XD_CDZ	42	I, pu	xD card detect 0: Card insert 1: No card
CF_CDZ	41	I, pu	CF card detect 0: Card insert 1: No card
SB1	32	B	CF_IORDY/xD_D2/MS_BS/SD_D1
SB2	33	B	CF_RSTZ/xD_D3/MS_D1/SD_D0
SB3	34	B	CF_IOWZ/xD_D4/MS_D0/SD_CLK
SB4	35	B	CF_IORZ/xD_D5/MS_D2/SD_CMD

SB5	36	B	CF_CS1Z/xD_D6/MS_D3/SD_D3
SB6	37	B	CF_CS0Z/xD_D7/MS_CLK/SD_D2
SB7	23	B	CF_DMACK/xD_CLE/MS_D4/SD_D7
SB8	24	B	CF_ADR1/xD_ALE/MS_D5/SD_D6
SB9	25	B	CF_DMARQ/xD_D0/MS_D6/SD_D5
SB10	26	B	CF_ADR2/xD_D1/MS_D7/SD_D4
SB11	27	B	XD_WPZ/SD_WP
SB12	19	B	CF_08/xD_RBZ
SB13	20	B	CF_D1/xD_REZ
SB14	21	B	CF_D0/xD_CEZ
SB15	22	B	CF_ADR0/xD_WEZ
CF_D2	18	B	CF Data
CF_D3	61	B	CF Data
CF_D4	59	B	CF Data
CF_D5	57	B	CF Data
CF_D6	55	B	CF Data
CF_D7	53	B	CF Data
CF_D9	17	B	CF Data
CF_D10	16	B	CF Data
CF_D11	60	B	CF Data
CF_D12	58	B	CF Data
CF_D13	56	B	CF Data
CF_D14	54	B	CF Data
CF_D15	52	B	CF Data
<b>Others</b>			
LED	43	O	Memory card access LED
SPI_CS	44	O	SPI interface: chip select
SPI_CK	45	O	SPI_CK/I2C_SCL
SPI_SI	46	O	SPI_MOSI(Connect to SPI flash data input) /I2C_SDA
SPI_SO	47	I	SPI_MISO(Connect to SPI flash data output)
RSTZ	62	I, pu	Chip reset, active low
TEST	15		Test Pin



**Notation:  
Type**

<b>O</b>	Output
<b>I</b>	Input
<b>B</b>	Bi-directional
<b>pu</b>	internal pull-up when input
<b>pd</b>	internal pull-down when input
<b>P</b>	Power / Ground
<b>A</b>	Analog

**Table 3.2 - LQFN46 Pin Description**

Pin Name	LQFN 46 Pin	Type	Description
<b>Power/Ground</b>			
AVDD12	3,46	P	Analog 1.2V power source
AVDD33	9,43	P	Analog 3.3V power source
DVDD12	21,42	P	Digital 1.2V power source
DVDD33	31,40	P	Digital 3.3V power source
V33IN	22	P	3.3V to 1.2V regulator power source. Input range from 1.8V to 3.3V.
VUHSI	30	P	SD 3.0 IO PAD Power, the power source of this pin comes from the internal regulator of GL3233 and no need of external power input
VBUS	38	P	5V Power source
PMOS	39	P	Card power 900mA
GND	6	P	Ground
<b>USB PHY Interface</b>			
DP	44	A	USB 2.0 D+
DM	45	A	USB 2.0 D-
TXN	1	A	USB 3.0 TX-
TXP	2	A	USB 3.0 TX+
RXN	4	A	USB 3.0 RX-
RXP	5	A	USB 3.0 RX+
RTERM	10	A	USB reference resistor. This pin is used to control the level of USB signal. A 680ohm, 1% resistor is recommended to be populated between RTERM and GND
X1	7	I	25MHz XTAL input. It can be connected to external 25MHz clock input
X2	8	B	25MHz XTAL output
<b>Memory Card Interface</b>			
SD_CDZ	20	I, pu	SD card detect 0: Card insert 1: No card
MS_INS	23	I, pu	MS insertion detect 0: Card insert 1: No card
XD_CDZ	32	I, pu	xD card detect 0: Card insert 1: No card
XD_RBZ	11	O	xD read/busy
XD_REZ	12	O	xD read enable
XD_CEZ	13	O	xD card enable
XD_WEZ	14	O	xD write enable
SB1	24	B	xD_D2/MS_BS/SD_D1

SB2	25	B	xD_D3/MS_D1/SD_D0
SB3	26	B	xD_D4/MS_D0/SD_CLK
SB4	27	B	xD_D5/MS_D2/SD_CMD
SB5	28	B	xD_D6/MS_D3/SD_D3
SB6	29	B	xD_D7/MS_CLK/SD_D2
SB7	15	B	xD_CLE/MS_D4/SD_D7
SB8	16	B	xD_ALE/MS_D5/SD_D6
SB9	17	B	xD_D0/MS_D6/SD_D5
SB10	18	B	xD_D1/MS_D7/SD_D4
SB11	19	B	SD_WP/xD_WPZ
<b>Others</b>			
LED	33	O	Memory card access LED
SPI_CS	34	O	SPI interface: chip select
SPI_CK	35	O	SPI_CK/I2C_SCL
SPI_SI	36	O	SPI_MOSI(Connect to SPI flash data input) /I2C_SDA
SPI_SO	37	I	SPI_MISO(Connect to SPI flash data output)
RSTZ	41	I, pu	Chip reset, active low

**Notation:**

<b>Type</b>	<b>O</b>	Output
	<b>I</b>	Input
	<b>B</b>	Bi-directional
	<b>pu</b>	internal pull-up when input
	<b>pd</b>	internal pull-down when input
	<b>P</b>	Power / Ground
	<b>A</b>	Analog



**Table 3.3 - LQFP48 Pin Description**

Pin Name	LQFP 48 Pin	Type	Description
<b>Power/Ground</b>			
AVDD12	1,4	P	Analog 1.2V power source
AVDD33	10,46	P	Analog 3.3V power source
DVDD12	23,45	P	Digital 1.2V power source
DVDD33	34,43	P	Digital 3.3V power source
V33IN	24	P	3.3V to 1.2V regulator power source. Input range from 1.8V to 3.3V.
VUHSI	33	P	SD 3.0 IO PAD Power, the power source of this pin comes from the internal regulator of GL3233 and no need of external power input
VBUS	41	P	5V Power source
PMOS	42	P	Card power 900mA
GND	7,22,32	P	Ground
<b>USB PHY Interface</b>			
DP	47	A	USB 2.0 D+
DM	48	A	USB 2.0 D-
TXN	2	A	USB 3.0 TX-
TXP	3	A	USB 3.0 TX+
RXN	5	A	USB 3.0 RX-
RXP	6	A	USB 3.0 RX+
RTERM	11	A	USB reference resistor. This pin is used to control the level of USB signal. A 680ohm, 1% resistor is recommended to be populated between RTERM and GND
X1	8	I	25MHz XTAL input. It can be connected to external 25MHz clock input
X2	9	B	25MHz XTAL output
<b>Memory Card Interface</b>			
SD_CDZ	21	I, pu	SD card detect 0: Card insert 1: No card
MS_INS	25	I, pu	MS insertion detect 0: Card insert 1: No card
XD_CDZ	35	I, pu	xD card detect 0: Card insert 1: No card
XD_RBZ	12	O	xD read/busy
XD_REZ	13	O	xD read enable
XD_CEZ	14	O	xD card enable
XD_WEZ	15	O	xD write enable
SB1	26	B	XD_D2/MS_BS/SD_D1

SB2	27	B	XD_D3/MS_D1/SD_D0
SB3	28	B	XD_D4/MS_D0/SD_CLK
SB4	29	B	XD_D5/MS_D2/SD_CMD
SB5	30	B	XD_D6/MS_D3/SD_D3
SB6	31	B	XD_D7/MS_CLK/SD_D2
SB7	16	B	XD_CLE/MS_D4/SD_D7
SB8	17	B	XD_ALE/MS_D5/SD_D6
SB9	18	B	XD_D0/MS_D6/SD_D5
SB10	19	B	XD_D1/MS_D7/SD_D4
SB11	20	B	SD_WP/XD_WPZ
<b>Others</b>			
LED	36	O	Memory card access LED
SPI_CS	37	O	SPI interface: chip select
SPI_CK	38	O	SPI_CK/I2C_SCL
SPI_SI	39	O	SPI_MOSI(Connect to SPI flash data input) /I2C_SDA
SPI_SO	40	I	SPI_MISO(Connect to SPI flash data output)
RSTZ	44	I, pu	Chip reset, active low

**Notation:**

<b>Type</b>	<b>O</b>	Output
	<b>I</b>	Input
	<b>B</b>	Bi-directional
	<b>pu</b>	internal pull-up when input
	<b>pd</b>	internal pull-down when input
	<b>P</b>	Power / Ground
	<b>A</b>	Analog

## CHAPTER 4 BLOCK DIAGRAM

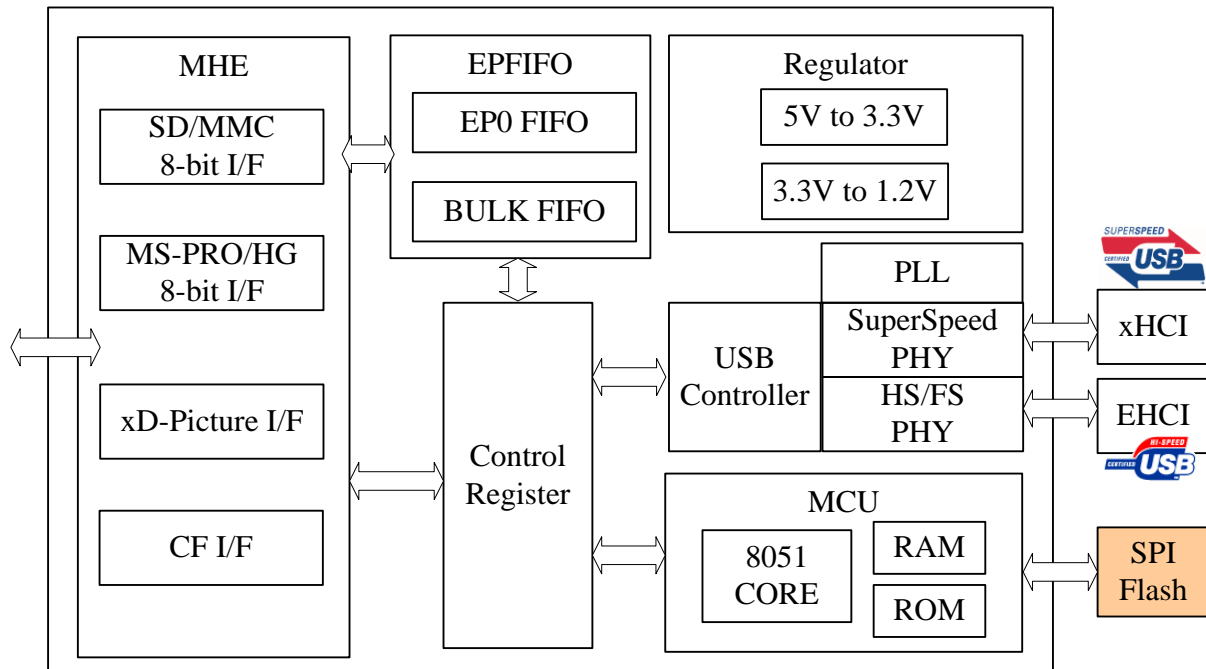

Figure 4.1 - Functional Block Diagram

### 4.1 Super Speed and HS/FS PHY

The transceiver macro is the analog circuitry that handles the low level USB protocol and signaling, and shifts the clock domain of the data from the USB to one that is compatible with the general logic.

### 4.2 USB Controller

The USB Controller, which contains the USB PID and address recognition logic, and other sequencing and state machine logic to handle USB packets and transactions.

### 4.3 EPFIFO

Endpoint FIFO includes Control FIFO (FIFO0) and Bulk In/Out FIFO

- **EP0 FIFO** FIFO of control endpoint 0. It is 512-byte FIFO and used for endpoint 0 data transfer.
- **Bulk In/Out FIFO** It can be in the TX mode or RX mode:
  1. It can be transmit/receive 512-byte data of USB 2.0 and 1K-byte data of USB 3.0 continuously.
  2. It can be directly accessed by micro-controller

### 4.4 MCU

8051 micro-controller inside.

- **8051 Core** Compliant with Intel 8051 high speed micro-controller
- **ROM** Firmware code on ROM
- **SRAM** Internal RAM area for MCU access



#### 4.5 MHE (Media Hardware Engine)

Media Interface: CF/xD/SD/MMC/MS/MS PRO/MS PRO-HG

#### 4.6 Regulator

- 5V to 3.3V      3.3V Power Source
- 3.3V to 1.2V    1.2V Power Source

## CHAPTER 5 ELECTRICAL CHARACTERISTICS

### 5.1 Temperature Conditions

**Table 5.1 - Temperature Conditions**

Parameter	Value
Storage Temperature	-65°C to +150 °C
Operating Temperature	0°C to +70 °C

### 5.2 Operating Conditions

**Table 5.2 - Operating Conditions**

Parameter	Value
Supply Voltage	+4.75V to +5.25V
Ground Voltage	0V
F <sub>OSC</sub> (Oscillator or Crystal Frequency)	25 MHz ± 0.03%

### 5.3 DC Characteristics

**Table 5.3 - DC Characteristics**

Symbol	Parameter	Condition	Min.	Typ.	Max.	Unit
V <sub>DD</sub>	Core Supply Voltage (DVDD12)		1.08	1.20	1.32	V
V <sub>CC</sub>	Supply Voltage		4.75	5	5.25	V
V <sub>IH</sub>	Input High Voltage		2.0			V
V <sub>IL</sub>	Input Low Voltage				0.4	V
I <sub>I</sub>	Input Leakage Current	0 < V <sub>IN</sub> < DVDD	-10		10	μA
V <sub>OH</sub>	Output High Voltage	DVDD = 3.3V	2.8			V
V <sub>OL</sub>	Output Low Voltage				0.4	V
I <sub>OH</sub>	Output Current High			8		mA
I <sub>OL</sub>	Output Current Low			8		mA
C <sub>IN</sub>	Input Pin Capacitance			5		pF
I <sub>NORMAL</sub>	HS mode			36		mA
	SS mode	U0 state		126		mA
		U1 state		26		mA
		U2 state		11		mA
I <sub>ACTIVE</sub>	HS mode			48		mA
	SS mode	U0 state		138.		mA
I <sub>RESET</sub>				32		mA

I <sub>SUS</sub>	HS suspend current	1.5K pull-up included	0.82	mA
	SS suspend current	U3 state	0.7	mA
R <sub>pu</sub>	Reset Pad pull-up		46	KΩ
	SD_CDZ, SD_WP, MS_INS, GPIO Pad pull-up		46	KΩ
	SD_CMD pull-up		15	KΩ
	SD_CLK, D[3:0] Pad pull-up		15	KΩ
R <sub>IMP</sub>	SD_CMD, SD_CLK, D[3:0] impedances		50	Ω

### 5.4 AC Characteristics of Reset Timing

#### 5.4.1 Reset Timing

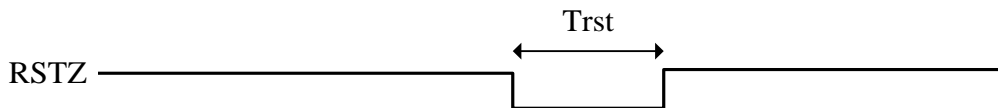

Figure 5.1 - Timing Diagram of Reset Width

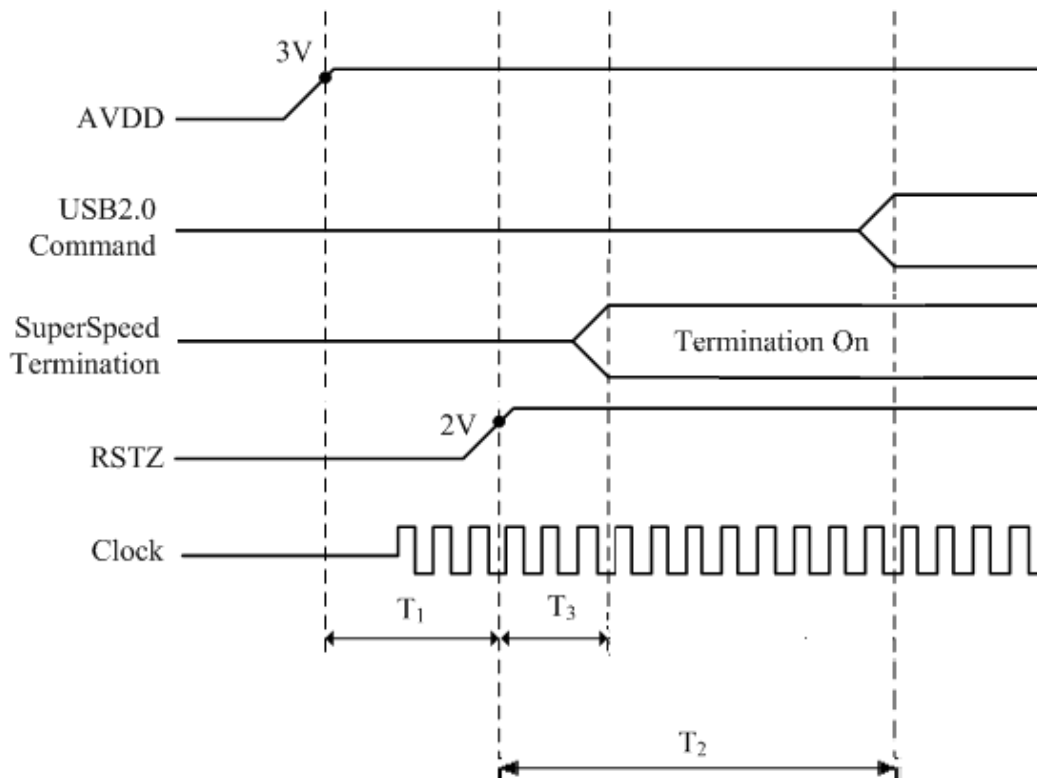

Figure 5.2 - Timing Diagram of Power Good to USB Command Receive Ready

**Table 5.4 - Reset Timing**

Parameter	Description	Min.	Max.	Unit
Trst	Chip reset sense timing width	2		us
T1	AVDD power up to reset de-assert	500		us
T2	Reset de-assert to respond USB2.0 command ready		95	ms
T3	Reset de-assert to SuperSpeed termination on		12	ms

### 5.4.2 SD/MMC Card Clock Frequency

**Table 5.5 - SD/MMC Card Clock Frequency**

Parameter	Description	Max.	Unit
F <sub>ID</sub>	Clock frequency Identification Mode	187	KHz
F <sub>DS</sub>	Clock frequency Default Speed Mode	25	MHz
F <sub>HS</sub>	SD Clock frequency High Speed Mode	50	MHz
F <sub>HS</sub>	MMC Clock frequency High Speed Mode	52	MHz
F <sub>SDR25</sub>	Clock frequency Ultra High Speed Mode: SDR25	50	MHz
F <sub>DDR50</sub>	Clock frequency Ultra High Speed Mode: DDR50	50	MHz
F <sub>SDR50</sub>	Clock frequency Ultra High Speed Mode: SDR50	100	MHz
F <sub>SDR104</sub>	Clock frequency Ultra High Speed Mode: SDR104	208	MHz

### 5.4.3 MS Card Clock Frequency

**Table 5.6 - MS Card Clock Frequency**

Parameter	Description	Max.	Unit
F <sub>DS</sub>	Clock frequency Default Speed Mode	20	MHz
F <sub>MSP</sub>	Clock frequency MS PRO 4bit Mode	40	MHz
F <sub>MSPHG</sub>	Clock frequency MS PRO HG 8bit Mode	60	MHz

## CHAPTER 6 SPI NOR FLASH SUPPORT LIST

Table 6.1 - SPI NOR Flash Support List

Vendor	Model
GigaDevice	GD25Q512
	GD25Q010
PMC	PM25LD512C
	PM25LD010
	PM25LD010C
	PM25LD020
	PM25LD020C
WINBON	W25X05CL
	W25X10CL
	W25X10BV
	W25X20CL
	W25X20BV
	EN25Q40
MXIC	MX25L1006E
	MX25L4006E
	MX25L512E
ESMT	F25L01PA-86PG
	F25L01PA-100PG
Giantec	GT25F512
FMSH	FM25F005
	FM25F01

**Note :**

- GL3233 support Page-Program SPI Flash only, not for Byte-Program SPI Flash
- Firmware file (xxxx.bin) which Genesys Logic provided is only used for Genesys Logic’s Multi-Tool and MP Tool ISP (In System Programming via USB interface) purpose. If you would like to provide FW to SPI Flash vendor for mass production or Flash ROM writer, please contact with GL technical support team.



## CHAPTER 7 PACKAGE DIMENSION

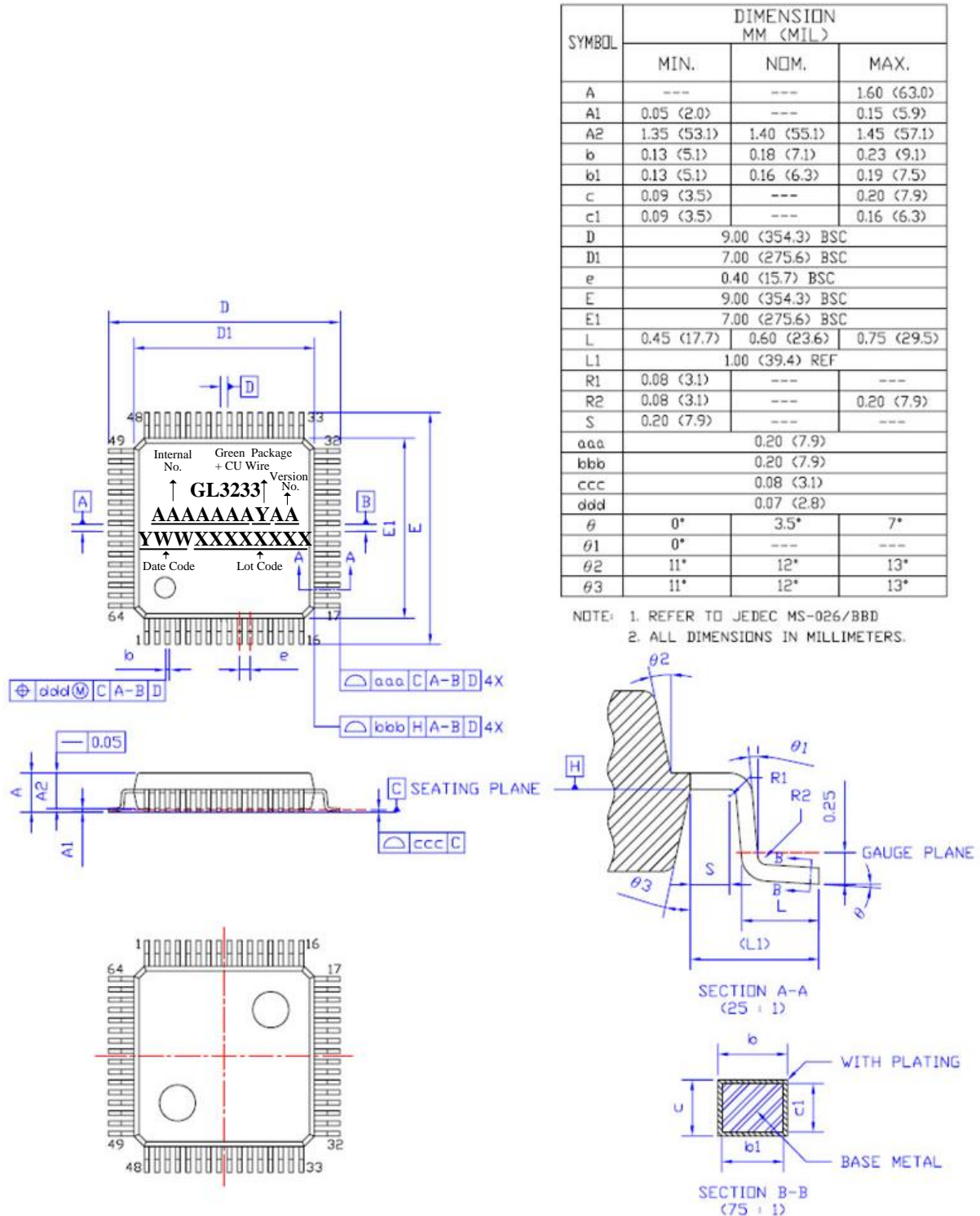

Figure 7.1 - LQFP 64 Pin Package

SYMBOL	DIMENSION MM (MIL)		
	MIN.	NOM.	MAX.
A	0.60 (23.6)	0.66 (26.0)	0.80 (31.5)
A1	---	0.02 (0.8)	0.05 (2.0)
A3	0.11 (4.3)	0.20 (7.9)	0.26 (10.2)
b	0.13 (5.1)	0.20 (7.9)	0.25 (9.8)
D	6.50 (255.9) BSC		
D2	4.95 (194.9)	5.10 (200.8)	5.25 (206.7)
E	4.50 (177.2) BSC		
E2	2.95 (116.1)	3.10 (122.0)	3.25 (128.0)
e	0.40 (15.7) BSC		
L	0.30 (11.8)	0.40 (15.7)	0.50 (19.7)

NOTE: 1. REFER TO JEDEC STD. MO-220  
2. ALL DIMENSIONS IN MILLIMETERS.

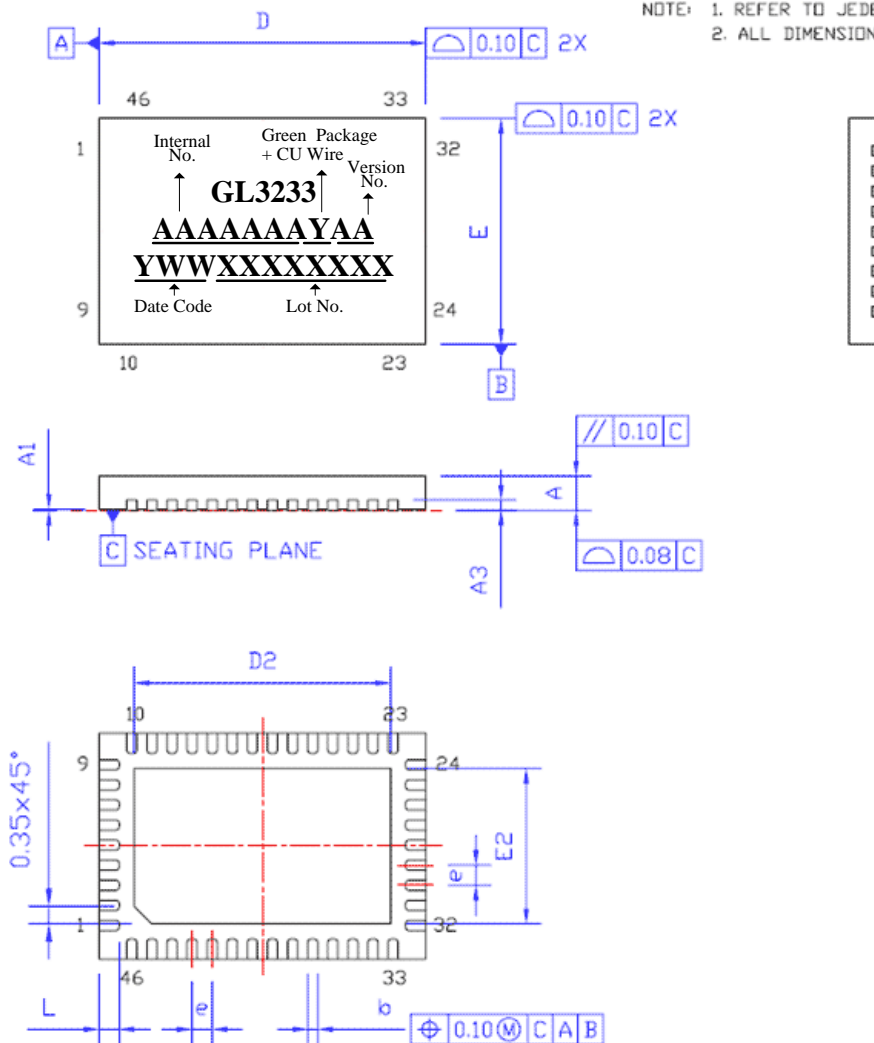

Figure 7.2 - LQFN 46 Pin Package

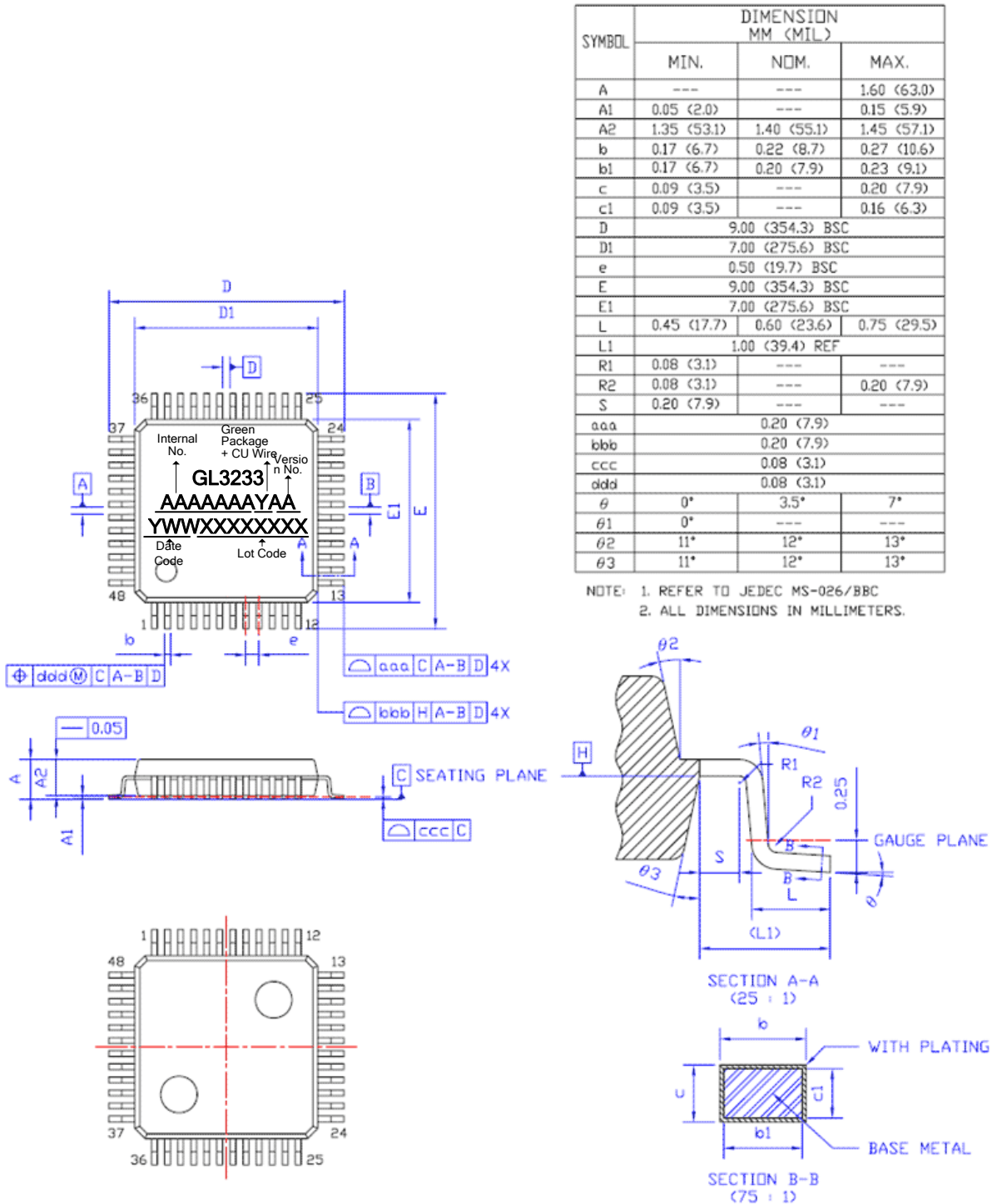

Figure 7.3 - LQFP 48 Pin Package

## CHAPTER 8 ORDERING INFORMATION

**Table 8.1 - Ordering Information**

Part Number	Package	Green/Wire Material	Version	Status
GL3233-MSYXX	LQFP 64	Green Package + CU Wire	XX	Available
GL3233-PMYXX	LQFN 46	Green Package + CU Wire	XX	Available
GL3233-MNYXX	LQFP 48	Green Package + CU Wire	XX	Available

## X-ON Electronics

Largest Supplier of Electrical and Electronic Components

*Click to view similar products for [USB Interface IC](#) category:*

*Click to view products by [Genesys](#) manufacturer:*

Other Similar products are found below :

[TUSB1146RNQT](#) [TUSB1146IRNQT](#) [CY7C65210-24LTXI](#) [CY7C69356-48LTXC](#) [CYUSB2304-68LTXI](#) [CY7C65642-48AXCT](#) [CYPD2119-24LQXI](#) [CYUSB3328-88LTXI](#) [USB2227-NU-11](#) [USB2251-NU-06](#) [USB3319C-GJ-TR](#) [USB3370B-EZK-TR](#) [USB5537B-4100AKZE](#) [USB3347-CP](#) [USB2230-NU-02](#) [USB2229-NU-02](#) [CG7648AM](#) [W83627HG-AW](#) [CY7C64225-28PVXCT](#) [CY7C65215A-32LTXI](#) [CYPD2120-24LQXI](#) [CYWB0164BB-BZXI](#) [CY7C65211A-24LTXI](#) [USB5807T-I/KD](#) [USB5742-I/2G](#) [USB3331E-GL-TR](#) [USB3321C-GL-TR](#) [USB1T1103MPX](#) [USB5742/2G](#) [CYPD2122-20FNXIT](#) [CYPD2122-24LQXIT](#) [LIF-UC120-SWG36ITR50](#) [MAX3456EETE+T](#) [LIF-UC120-CM36ITR50](#) [UPD360-C/6HX](#) [USB2228-NU-11](#) [UPD360-B/6HX](#) [PI3EQX7841ZDEX](#) [CYPD4225-40LQXI](#) [LAN7800-I/VSX](#) [UPD360T-B/6HX](#) [UPD360-A/6HX](#) [LAN7800/VSX](#) [MAX20037ATIB/V+](#) [MP5030CGQH-P](#) [USB7056/KDX](#) [STUSBCD01BJR](#) [CY7C65642-28LTXCT](#) [CG8454AM](#) [CYPD2119-24LQXIT](#)